

**REPORT DOCUMENTATION PAGE**

Form Approved OMB No. 0704-0188

Public reporting burden for this collection of information is estimated to average 1 hour per response, including the time for reviewing instructions, searching existing data sources, gathering and maintaining the data needed, and completing and reviewing the collection of information. Send comments regarding this burden estimate or any other aspect of this collection of information, including suggestions for reducing the burden, to Department of Defense, Washington Headquarters Services, Directorate for Information Operations and Reports (0704-0188), 1215 Jefferson Davis Highway, Suite 1204, Arlington, VA 22202-4302. Respondents should be aware that notwithstanding any other provision of law, no person shall be subject to any penalty for failing to comply with a collection of information if it does not display a currently valid OMB control number.  
**PLEASE DO NOT RETURN YOUR FORM TO THE ABOVE ADDRESS.**

<b>1. REPORT DATE (DD-MM-YYYY)</b> 16-05-2006	<b>2. REPORT TYPE</b> Final Report	<b>3. DATES COVERED (From – To)</b> 01-Feb-04 - 16-May-06
--	---------------------------------------	--

<b>4. TITLE AND SUBTITLE</b>  Ti-Based Metal Matrix Composites Reinforced with TiB Particles	<b>5a. CONTRACT NUMBER</b> STCU Registration No: P-132
	<b>5b. GRANT NUMBER</b>
	<b>5c. PROGRAM ELEMENT NUMBER</b>

<b>6. AUTHOR(S)</b>  Professor Orest M Ivasyshyn	<b>5d. PROJECT NUMBER</b>
	<b>5d. TASK NUMBER</b>
	<b>5e. WORK UNIT NUMBER</b>

<b>7. PERFORMING ORGANIZATION NAME(S) AND ADDRESS(ES)</b> Institute for Metal Physics 36 Vernadsky Street Kyiv 03142 Ukraine	<b>8. PERFORMING ORGANIZATION REPORT NUMBER</b>  N/A
--	--

<b>9. SPONSORING/MONITORING AGENCY NAME(S) AND ADDRESS(ES)</b>  EOARD PSC 821 BOX 14 FPO 09421-0014	<b>10. SPONSOR/MONITOR'S ACRONYM(S)</b>
	<b>11. SPONSOR/MONITOR'S REPORT NUMBER(S)</b> STCU 00-8013

**12. DISTRIBUTION/AVAILABILITY STATEMENT**  
  
Approved for public release; distribution is unlimited.

**13. SUPPLEMENTARY NOTES**

**14. ABSTRACT**

This report results from a contract tasking Institute for Metal Physics as follows: Reinforcement of a titanium matrix by TiB particles leads to increased tensile strength, creep resistance, Young's modulus, hardness and wear resistance of the composite material. This study will develop a scientific background of processing Ti/TiB in-situ composite material through ingot melting followed by hot working and heat treatment. The aim of the present study is to establish the potential of a melting approach to produce discontinuously reinforced Ti/TiB composites with a homogeneous distribution of fine TiB particles for improved mechanical properties at reduced cost.

**15. SUBJECT TERMS**  
EOARD, Materials, Metallurgy and Metallography

<b>16. SECURITY CLASSIFICATION OF:</b>			<b>17. LIMITATION OF ABSTRACT</b> UL	<b>18. NUMBER OF PAGES</b>  77	<b>19a. NAME OF RESPONSIBLE PERSON</b> JOAN FULLER
<b>a. REPORT</b> UNCLAS	<b>b. ABSTRACT</b> UNCLAS	<b>c. THIS PAGE</b> UNCLAS			<b>19b. TELEPHONE NUMBER</b> (Include area code) +44 (0)20 7514 3154

**“Ti-based metal matrix composites reinforced with TiB particles”**

Project manager: Prof. O.M.Ivasishin

Tel: (044) 424-22-10, Fax (044)424-33-74, E-mail [ivas@imp.kiev.ua](mailto:ivas@imp.kiev.ua)

Kurdyumov Institute for Metal Physics NASU, Kyiv,

Project duration: 01 February 2004 – 31 January 2006

Financing countries: USA, EOARD

Reporting period: 01.02.2004-30.04.2004

Date of report presentation: 17.05.2004

Project code according to the Science and Technology Area: Primary: 3, 5; Secondary: 11, 13

Content of report of project executing in Quarter 01	Q01 PAGE 1
1. Short summary of progress	Q01 PAGE 1
2. Summary of personnel commitments	Q01 PAGE 4
3. Description of business travel	Q01 PAGE 5
4. Current status	Q01 PAGE 5
5. Overcome problems	Q01 PAGE 5
6. Delays and proposals	Q01 PAGE 5
Financial report for 01 quarter (agreed with financial officer) – attached	ActP132-01.s

**1. Short summary of progress in Quarter 01**

During 1<sup>st</sup> quarter, activity #1 was being performed.

*Activity title* 1. Investigation of influence of technological method of boron alloying, boron content and rate number and cooling on microstructural features of Ti-TiB eutectic.

*Works performing during the stage*

This activity is planned for 1st – 2nd quarters of project.

I. In the 1st quarter, the influence of technological methods of boron additions on (a) degree of boron recovery at vacuum arc melting and (b) morphological features of boride constituent was investigated.

(a) Twelve binary Ti-B ingots (30 g) of different compositions were melted employing laboratory vacuum arc furnace. Ingot compositions (by charge) and starting materials are presented in Table 1.

The alloys were produced with either titanium sponge of TG-100 grade or iodine titanium (99,9% purity). Boron was added as (i) elemental amorphous powder, 99.996% purity or (ii) commercially produced TiB<sub>2</sub> powder, or (iii) master alloy of TiB composition synthesized at IMP through press-and-sinter route from titanium hydride / amorphous boron powder blend. In the last case the master alloy was a porous substance crushed to a size of 2-3 mm while size fractions of elemental boron and TiB<sub>2</sub> were much finer (0.5 and 4 μm respectively). The quantitative results of boron recovery were determined by analysis (see Table 1) and controlled with metallography and differential thermal analysis (DTA). It was found that maximal boron losses, due to blowing of powders by arc plasma, took place with employment of elemental boron (up to 50%) and TiB<sub>2</sub> (up to 25%). Boron was nearby 100% consumed if boron was added as the synthesized TiB master alloy.

According to DTA, melting temperature of Ti+TiB eutectic was 1535± 5°C (1540±10°C is known as reference temperature).

Microhardness of eutectic constituent in binary alloys gradually increased with boron content: it was  $2770 \pm 60$  MPa for eutectic composition but decreased to  $2630 \pm 60$  MPa or increased to  $3120 \pm 60$  MPa for compositions corresponding to hypo- or hypereutectic microstructures respectively. Such data imply formation of pseudo eutectics having different content of boride phase.

Table 1  
Composition of Ti-B binary alloys.

#	B, wt.% (in charge)	B, wt.% (in ingot)	Starting materials
TiB-1	0.81	0.42	Ti ( sponge) +B
TiB-2	1.67	0.85	Ti ( sponge) +B
TiB-3	2.45	1.30	Ti ( sponge) +B
TiB-4	0.81	0.51	Ti (iodine) +B
TiB-5	1.67	0.90	Ti (iodine) +B
TiB-6	2.45	1.43	Ti (iodine) +B
		Mass TiB <sub>2</sub> , (g)	
TiB-7	0.81	0.62	Ti (iodine) +TiB <sub>2</sub>
TiB-8	1.67	1.27	Ti (iodine) +TiB <sub>2</sub>
TiB-9	2.45	1.93	Ti (iodine) +TiB <sub>2</sub>
		Mass TiB (g)	
TiB-10	0.81	0.8	Ti (iodine) +TiB
TiB-11	1.67	1.61	Ti (iodine) +TiB
TiB-12	2.45	2.42	Ti (iodine) +TiB

b) No visible influence of boron addition method (if similar compositions were achieved) on eutectic morphology was found in Ti-B alloys. As it could be expected, Ti+TiB eutectic was found to be a skeleton type eutectic with anomalous structure in which TiB is a leading phase in a formation of eutectic colonies. It was found with light microscopy and scanning electron microscopy that at fast cooling ( $50\text{Ks}^{-1}$ ) of laboratory-scale 30 g samples boride particles were fine but their morphological features depended on alloy composition. For compositions below eutectic boride particles were located between titanium dendrites. Dendrite parameter was of about  $20 \mu\text{m}$ . Boride particles were most often needle-like or sometimes, fine plate-like. Nucleating TiB crystals were not distinguishable in the microstructure because of their small size. In eutectic composition, two types of eutectic colony TiB nucleating crystals (base crystals) were found: of round or faceted cross-section, each leading to a formation of a specific morphology of eutectic colonies. The former crystals, more numerous, were generally smaller (in cross-section) having 2-3  $\mu\text{m}$  in diameter and aspect ratio of about 10. While

growing into melt, they split into a bunch of needles of about 0.3  $\mu\text{m}$  in diameter. Differentiation of colonies continued with their growth. Faceted nucleating crystals were hexahedral prisms with  $\langle 001 \rangle$  direction of the fastest growth. Transformation of faceted crystal into an eutectic colony was following: crystal facet  $\Rightarrow$  basic plate parallel to facet  $\Rightarrow$  plate packet formed due to differentiation of basic plate  $\Rightarrow$  transverse splitting of separate plates  $\Rightarrow$  splitting into individual fibers. The fibers had either round, 1  $\mu\text{m}$  in diameter, or rectangular, roughly 1x3  $\mu\text{m}$ , cross section. Thickness of boride plates was about 1  $\mu\text{m}$ , width was 3 to 20  $\mu\text{m}$ . Transverse corrugations were often observed at flat plate surfaces. In some cases orthogonal branches originated from these corrugations forming separated packets in the course of growth. Interlamellar spacing in packets was 2 to 5  $\mu\text{m}$ .

Table 2.

Alloy	B, wt.%	Al, wt.%	V, wt.%	% Ti
TiB-13	1.67			Balance
TiB-14	1.67	6		Balance
TiB-15	1.67		4	Balance
TiB-16	1.67	6	4	Balance

To study the impact of vanadium and aluminum on eutectic microstructure, four alloys were additionally melted (Table 2). Main trends observed at crystallization of binary Ti-B eutectic were seen at crystallization of (Ti-6Al-4V)+TiB eutectic as well. Two specific features should be mentioned, however.

(1) At equal boron content, alloying with vanadium and aluminum changed a ratio of round and faceted nucleating crystals, to the favor of faceted ones and, hence, increased fraction of plate-like boride constituent. TiB crystals were generally coarser in alloyed eutectic as compared to binary Ti-B alloy and sometimes looked as a constituent of hypereutectic microstructure. The last led to a conclusion that in (Ti-6Al-4V)+TiB alloys, eutectic content of boron is lower than in binary Ti-B alloys (1.67%). Such conclusion was confirmed with observation of small thermal effect on DTA curves due to crystallization of minor amount of primary boride crystals. This result was in an agreement with results of thermodynamic calculations for (Ti-6Al-4V)-B alloys, presented by Dr. Miracle. Variation in boron content for Ti-6Al-4V-B alloys will be experimentally performed in the next quarter. Depending on the results, composition of Scale 2 and Scale 3 ingots will be corrected.

(2) Alloying resulted in some faceted crystals to become hollow. Electron microprobe analysis showed that composition of solid solutions inside and outside of crystal wall was different. In particular, a significant excess of aluminum was measured inside apparently due to low solubility of aluminum in TiB. Contrary, no difference in vanadium content was found. Thus, formation of hollow crystals could be explained by piling up of aluminum before fast growing TiB (001) plane.

II. Since cooling rate of Scale 2 and Scale 3 ingots (induction and induction-arc melting) is expected to be considerably lower than those for laboratory arc furnace, the influence of cooling rate on morphological features of (Ti-6Al-4V)+TiB eutectic was studied.

Experiments were conducted for cooling rates of 0.17, 0.7, 1.3 and 2.7 Ks<sup>-1</sup> using the DTA facility. Zones with degenerated microstructure were observed in samples cooled with rates of 0.17 and 0.7 Ks<sup>-1</sup>. Such zones consisted from coarse plates 5 to 15 μm thick, distance between them varied from 20 to 150 μm. There was no regularity in plate orientation within zones. At cooling rates of 1.3 Ks<sup>-1</sup> and higher the eutectic structure became colony-like. Increase in cooling rate above 1.3 Ks<sup>-1</sup> led to finer boride constituent, slightly higher amount of boride constituent in eutectic and its gradual transformation from plate-like to fiber-like geometry.

Due to high directionality of interatomic bonds in TiB, for cooling rates under 50 Ks<sup>-1</sup> orientation of colonies was determined not by temperature gradient but by orientation of the primary boride crystals. The effect of temperature gradient became pronounced, however, for even higher cooling rates (~100 Ks<sup>-1</sup>) achieved in the thin layer near the water-cooled crucible wall. Such microstructure gradient was observed in samples cooled in copper crucible 6 mm in diameter.

III. Additionally to the working plan of first quarter:

- Ingots alloyed with Zr to modify the eutectic microstructure were melted. Microstructure is now under investigation.
- Preliminary investigations of hot deformation influence on microstructure of Ti-6Al-4V-1.67B alloy were performed. The following deformation regimes were employed:
  - Rolling at 1050°C with up to 80% reductions;
  - 3D forging at 1050°C (40% reduction for each direction).

SEM microstructure investigations revealed a considerable refinement of boride constituent.

## 2. Summary of personnel commitments.

Personnel FWS and NFWS were employed in accordance with Project Agreement with some correction of real working time. Participants were employed in the following activities:

<i>Participants</i>	<i>Activities</i>
Ivasishin	1
Ivanchenko	1
Teliovich	1
Markovsky	1
Garasym	1
Pogrebnyak	1
Savvakina	1
Bondareva	1
Levicka	1

**3. Description of business travel.**

There were no business trips during the 1st quarter. During his business trip to Charlotte (TMS 2004 Annual Meeting) in the frame of P-057 project Prof. Ivasishin met Dr. Miracle for short discussions on the project.

**4. Current status.**

Investigations and organizing works are being performed in accordance with the working schedule.

**5. Overcome problems.**

None.

**6. Delays, proposals.**

None.

**Financial report for quarter 1 (agreed with financial officer) - is added**

*Project Manager*

*O.M.Ivasishin*

*Data: May 17, 2004*

*Project coordinator*

*S. Slusarenko*

*Deputy of*

*Executive Director*

*J. Zimmerman*

## “Ti-based metal matrix composites reinforced with TiB particles”

Project manager: Prof. O.M.Ivasishin

Tel: (044) 424-22-10, Fax (044)424-33-74, E-mail [ivas@imp.kiev.ua](mailto:ivas@imp.kiev.ua)

Kurdyumov Institute for Metal Physics NASU, Kyiv,

Project duration: 01 February 2004 – 31 January 2006

Financing countries: USA, EOARD

Reporting period: 01.05.2004-30.09.2004

Date of report presentation: 09.10.2004

Project code according to the Science and Technology Area: Primary: 3, 5; Secondary: 11, 13

Content of report of project executing in Quarter 02	Q02 PAGE 1
1. Short summary of progress	Q02 PAGE 1
2. Summary of personnel commitments	Q02 PAGE 4
3. Description of business travel	Q02 PAGE 5
4. Current status	Q02 PAGE 5
5. Overcome problems	Q02 PAGE 5
6. Delays and proposals	Q02 PAGE 5

### 1. Short summary of progress in Quarter 02

*Activity number and title* 1. Investigation of the general influence of melt charge composition, melting regimes and subsequent solidification conditions on the microstructure (size and shape of basic crystals of eutectic grains, peculiarities of matrix phase) of alloys.

*Works*

*performing during the stage*

This activity is being performed during the 1<sup>st</sup> – 4<sup>th</sup> quarters of project. In the 2<sup>nd</sup> quarter the following works were carried out:

1) The eutectic composition in Ti-6Al-4V-xB alloying system was determined.

Since it was found earlier (see 1<sup>st</sup> quarter Progress Report) that alloying with 1.67%B (eutectic composition for Ti-B binary system) led to hypereutectic microstructure in Ti-64B alloy, it was necessary to define eutectic boron content. Differential Thermal Analysis (DTA) techniques were used. Scale 1 ingots with 1.4, 1.5, 1.55, 1.6 and 1.65 wt.%B were melted in a lab induction furnace. Absence of thermal effects of either  $\beta$ -phase or TiB primary crystals solidification during cooling was taken as a criterion. Such thermal effects were not observed only for the Ti-6Al-4V-1.55B composition. Therefore, it was concluded that **1.55 ± 0.05 wt.% B corresponds to the eutectic composition.**

2) Influence of boron content on the beta-transus temperature of Ti-64B alloys was investigated.

Since redistribution of Ti, Al, and V between matrix and boride constituents changes the composition of Ti-6Al-4V matrix, its beta-transus should also change, depending on volume fraction of boride (or boron content) and solubility of Al and V in boride. Data on solubility were obtained with microprobe analysis: V – 3.3 wt.%, Al – 0.02 wt.%. Using these values, the dependence of matrix composition on boron content was calculated for the Ti 6-4 alloy (Fig. 1). Experimental result obtained for 1.5 wt. %B content well correlate with calculations.

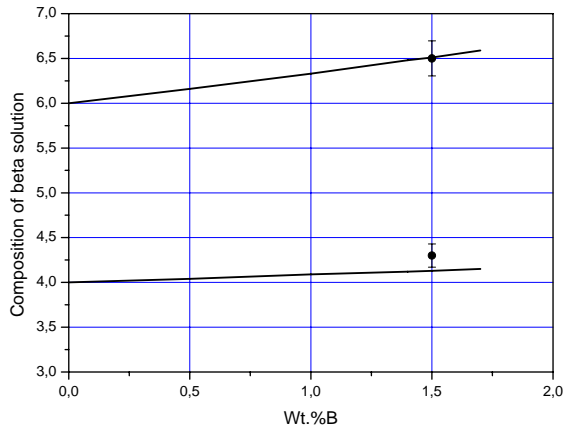

Fig. 1. Expected matrix composition, depending on boron content, for the Ti-64B and experimental results measured for Ti-6Al-4V-1.55B alloy.

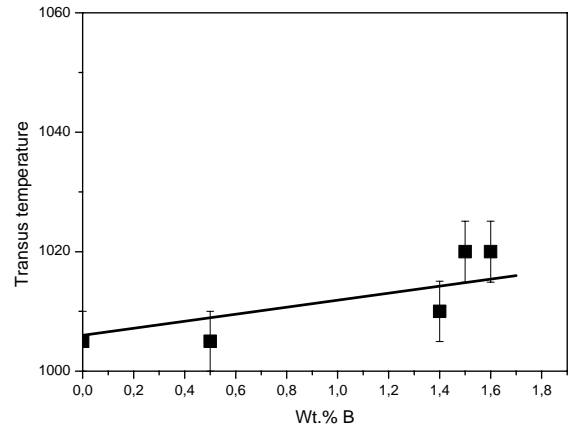

Fig. 2. Dependence of  $\beta$  transus temperature on boron content in the Ti-64B system.

In turn, boron dependence of matrix chemistry was easily transformed into boron dependence of beta-transus (Fig.2) using respective coefficients for aluminum (16.7) and vanadium (-9.1) [Lazarev V.G., Polyakova T.K. Non-ferrous metals (Zvetnye metally, in Russian), 1982, 3, 86-87]. Beta transus for zero boron content base alloy (1006°C) was calculated for the composition Ti-6Al-4V-0.20-0.025N, basing on averaged measurements of interstitials contents in Scale 1 ingots. Experimental results on boron dependence of matrix beta transus (see Fig.2) were obtained with DTA technique and checked with resistometry.

### 3) Induction melting and characterization of Scale 2 ingots.

The Scale 2 ingots were melted in induction furnace inside a water-cooled sectioned copper crucible. As a charge, TG-110 titanium sponge, 60/40 Al/V master alloy and TiB synthesized from  $\text{TiH}_2 + \text{B}$  blend (see 1<sup>st</sup> quarter Progress report) were used. The charge was divided into 40 increments which were added one by one after previous portion had been melted. Dividing of charge provided an uniform chemistry along the ingot. As next portion was added the inductor moved up; melt pool was formed in accordance with a position of inductor.

Two ingots with 1,5 (hereafter referred to as ingot #2-1) and 1,4 (hereafter referred to as ingot #2-2) wt.% B were melted. Hypoeutectic type of microstructure was better seen in ingot #2-2 (Fig. 3a). Chemistry of alloys met nominal composition. Due to peculiarities of melting techniques each ingot comprised of two slightly different zones. Upper zone formed during final melting stage when solidification occurred in a steady regime (inductor moved with a fixed rate) was very uniform microstructurally. Boride precipitated as high aspect ratio plates and needles 1-3  $\mu\text{m}$  thick (Fig. 3b). The second zone was formed in lower part of ingot where metal solidified at varying conditions caused by step-wise movement of the inductor. In this zone, wide bands with the microstructure described above were alternated by narrow bands comprised of a coarser conglomerate of matrix and borides.

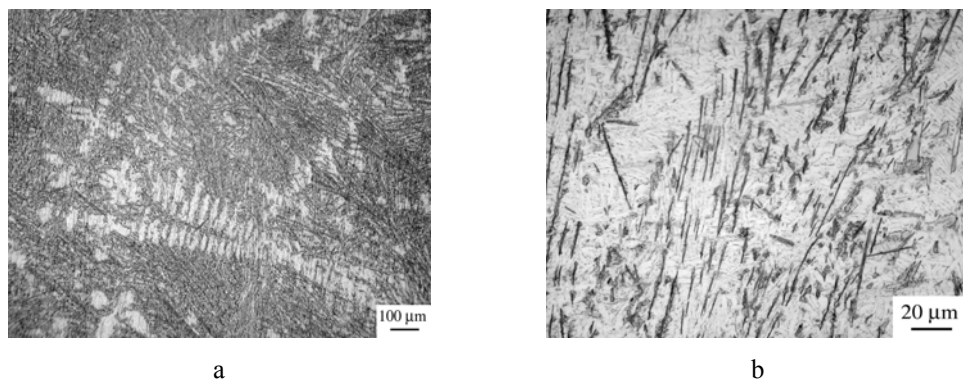

a

b

Fig. 3. Microstructure of as cast Ti-6Al-4V-1.4B.

#### 4) Melting technique for Scale 3 (dia. 70 mm) ingots was developed.

It is planned that Scale 3 ingots will be melted using VAR approach with an additional induction heating. The last allows for better uniformity of ingot chemistry through stirring of the melt. As consumable electrodes, Scale 2 ingots (dia. 30 mm) will be used. VAR of Scale 2 ingots are expected to improve their uniformity.

To model possible nonuniformities in electrode, first experimental Scale 3 ingot was melted from the electrode made out of bar of commercial VT6 (Ti-6Al-4V) alloy and  $AlB_2$  master alloy placed into holes in the electrode. Afterwards these holes were sealed with titanium sponge and iodine vanadium.

LM and SEM of Scale 3 ingot showed uniform microstructure with coarser borides as compared to Scale 2 ingots, what was expected because of lower cooling rate. The borides were plates and needles 2-5  $\mu m$  thick.

*Activity number and title*

*3. Determination of the thermomechanical processing and heat treatment conditions required to control and produce desired microstructure. Studying of the influence of different regimes of hot deformation and heat treatment on final microstructure and mechanical properties of Ti-6Al-4V/TiB eutectic alloy.*

*Works performing during the stage*

This activity is being performed during 2<sup>nd</sup>-8<sup>th</sup> quarters of project

In the 2<sup>nd</sup> quarter investigation of hot deformation effect on microstructure transformation in Scale 2 ingots upon thermomechanical processing was started.

Following processing regimes were employed:

3D-forging,  $T = 1100^\circ C$ ; 50% reduction in each direction.

2 D-rolling,  $T = 1050^\circ C$ ,  $20 \times 20 \text{ mm} \Rightarrow 10 \times 10 \text{ mm}$  cross-section reduction.

LM and SEM studies has shown an effective refinement of the boride constituent with both types of processing (Fig. 4a,b,c). Besides, hot deformation significantly favored structural homogeneity of ingots. Dendrite structure of hypo-eutectic alloy 2-2 was less pronounced after hot deformation. Pores between fragments of crashed borides were not revealed. Rolling resulted in preferable arrangement of refined boride particles along rolling direction (Fig. 4 b,c).

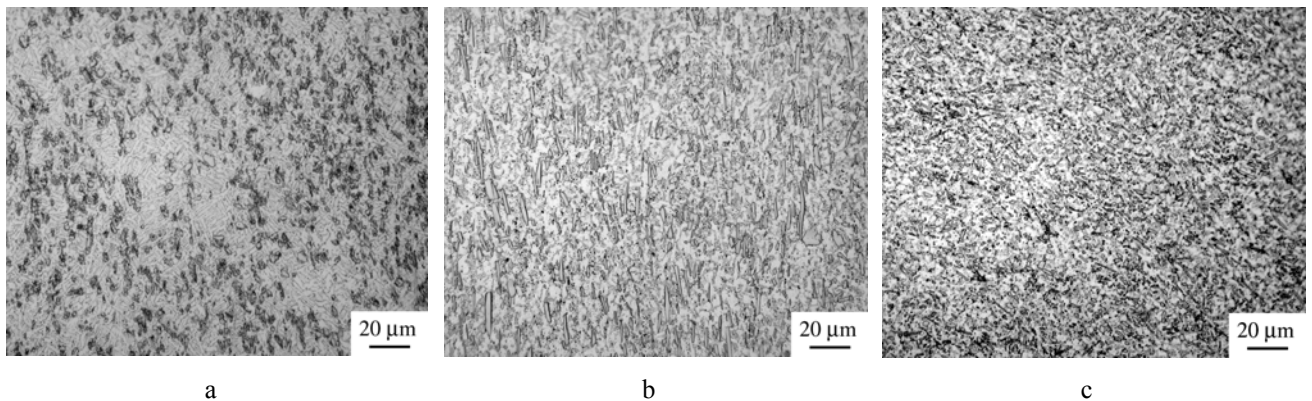

Fig. 4. Microstructure of Ti-6Al-4V-1.4B alloy: (a) 3D forged; (b) 2D rolling, longitudinal, (c) 2D rolling, transverse.

Results of tensile tests of the processed (rolled) 2-2 alloy are shown in Fig. 5 in comparison with AFRL results for lower boron content alloys (as cast + HIP condition).

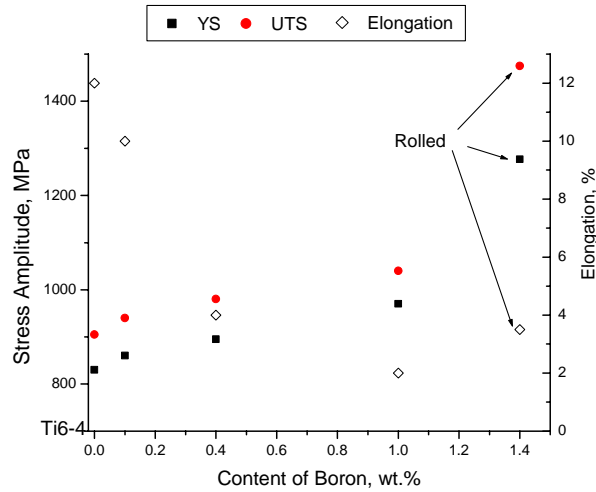

Fig. 5 Effect of boron addition on the tensile properties of Ti-6-4 alloys. Data for boron content 0.0 to 1.0 wt. % were taken from: FY04 LDF Project Progress Report.

**2. Summary of personnel commitments.**

Personnel FWS and NFWS were employed in accordance with Project Agreement with some correction of real working time. Participants were employed in the following activities:

<i>Participants</i>	<i>Activities</i>
Ivasishin	1, 3
Ivanchenko	1, 3
Teliovich	1, 3
Markovsky	1, 3
Garasym	1, 3
Pogrebnyak	1
Savvakin	1, 3
Bondareva	1, 3
Levicka	1

**3. Description of business travel.**

Project manager Orest M. Ivasishin was in Zaporozhye visiting Titanium-Magnesium Plant and Titanium Institute for discussions on raw materials (titanium sponge, master alloys) quality and possibility of supply.

**4. Current status.**

Investigations and organizing works are being performed in accordance with the working schedule.

**5. Overcome problems.**

None.

**6. Delays, proposals.**

None.

*Project Manager*  
**O.M.Ivasishin**  
 Data: October 08, 2004

*Project coordinator*  
**S. Slusarenko**

*Deputy Executive Director*  
**J. Zimmerman**

**“ Ti-based metal matrix composites reinforced with TiB particles”**

*Project manager: Prof. O.M.Ivasishin*

*Tel: (044) 424-22-10, Fax (044)424-33-74, E-mail [ivas@imp.kiev.ua](mailto:ivas@imp.kiev.ua)*

*Kurdyumov Institute for Metal Physics NASU, Kyiv,*

*Project duration: 01 February 2004 – 31 March 2006*

*Financing countries: USA, EOARD*

*Reporting period: 01.10.2004-31.12.2004*

*Date of report presentation: 5.01.2005*

*Project code according to the Science and Technology Area: Primary: 3, 5; Secondary: 11, 13*

Content of report of project executing in Quarter 03

1. Short summary of progress	Q03 PAGE 1
2. Summary of personnel commitments	Q03 PAGE 4
3. Description of business travel	Q03 PAGE 4
4. Current status	Q03 PAGE 4
5. Overcome problems	Q03 PAGE 4
6. Delays and proposals	Q03 PAGE 4
Financial report for 03 quarter (agreed with financial officer) – attached	ActP132-03.s

### 1. Short summary of progress in Quarter 03

During the 3<sup>rd</sup> quarter, activities #1 and #3 were being performed.

*Activity* 1. *Investigation of general influence of melt charge composition, melting regimes and number and subsequent solidification conditions on the microstructure (size and shape of basic crystals of title eutectic grains, peculiarities of matrix phase) of alloys.*

*Works*

*performing* This activity is being performed during the 1st – 4 th quarters of project. In the 3 rd quarter *during the* the following works were performed: *stage*

Manufacturing route for production of the Scale 3 ingots, developed in this project, was used to melt Ti-6Al-4V-1.55B ingot . To ensure a homogeneous distribution of alloying elements through the ingot, two stage melting procedure was chosen. At the first stage, prealloyed ingots 35 mm in diameter (Scale 2) were melted using the vacuum induction melting techniques described earlier (see Q02 Pogress Report). After rough machining of their surface, a consumable electrode was manufactured by joining three Scale 2 ingots (Fig. 1). This electrode was remelted into Scale 3 ingot 72 mm in diameter (Fig. 2) in vacuum arc-induction furnace. The principal feature of VAIR as compared to standard VAR process consists in additional to arc, high frequency induction source of heating which provides also

stirring of melt and thus, more uniform alloying. The composition of ingot was found to be Ti-5.46±.2Al-3.95±0.1V-1.53±0.05B (average of three analysis) as compared to charge Ti-6A-4V-1.55B. Transverse macrostructure of ingot consisted of three zones (Fig. 3). The very surface zone of nearly 2.0 mm thick contained fine boride particles, mainly of needle shape, 2-7 μm in diameter and with aspect ratio of up to 30, imbedded into titanium matrix. Borides were randomly oriented with no indication of colony type morphology. The second zone was characterized by colony type eutectic structure strongly oriented in radial direction. Its thickness was up to 5 mm, bigger in upper part of ingot. Microstructure of the area located between the first and second zones is presented in Fig. 4. The oriented zone was gradually replaced by third zone, which consisted from randomly oriented eutectic grains. In turn, this zone was not uniform and included areas with homogeneous distributions of boride needles and plates (Fig. 5,a) and areas in which degenerated eutectic microstructure was formed. Generally, the last looked as boride free areas in which a relative coarse single boride crystals were seen (Fig. 5 b). The closer to the ingot axis the higher was a volume fraction of areas with degenerated microstructure. This implies that low cooling rate could be responsible for its formation. It is known that at very slow cooling eutectic microstructure can degenerate into a coarse mixture (conglomerate) of two phases losing all features of cooperative transformation. Since the degenerated eutectic areas were very often located between eutectic grains with regular structure, it can be speculated that cooling rate is the lowest in molten microvolumes where growing eutectic grains meet each other.

In general, it was well recognized that microstructure of Scale 3 ingot was coarser than that of Scale 2 ingot early described (see Q02 Progress Report), what was certainly due to lower cooling rate. Currently, statistic treatment is being performed for quantitative comparison of two microstructures. Having a coarse, and moreover nonuniform as-cast microstructure, Scale 3 ingots will certainly require more severe hot working to finally reach a fine, uniform microstructure. As though it was decided, while discussing this point with Dr. Daniel Miracle, to carry out very thorough investigation on as-cast/thermomechanically processed microstructure transformation, instead of going to next scale, 200 mm in diameter ingots in which as-cast microstructure nonuniformities will be even more pronounced.

The influence of microalloying on phase composition and microstructure of eutectic Ti(Al,V) – TiB alloy was studied. Scale 1 ingots (30 g, 6 mm in diameter) Ti-64-B with additions of Zr or Hf were melted (Table 1). Boron content varied as 1.55 or 1.67 % to get or fully eutectic or hypereutectic, with coarse primary borides, microstructures. The alloys were examined using light microscopy, SEM, DTA, X-ray and EMPA. There were two suggestions as to the possible role of alloying with Zr (Hf). First, it was thought that Zr (Hf) could form fine borides before TiB was formed and thus, refine the primary TiB morphology. It should be immediately said that such borides were never found. X-ray analysis showed that alloys consisted of α, β and TiB phases, only. Follows from EMPA data presented in Fig.6, taking Zr as example, that Zr is redistributed between Ti matrix and

boride in proportion of 10:1.

Table 1. The composition of examined alloys.

#	Wt. % Ti	Wt.% Al	Wt.% V	Wt.% B	Wt.% Zr	Wt.% Hf
132/6	Balance	6	4	1.67	1	
132/11	Balance	6	4	1.67		1
132/32	Balance	6	4	1.55	0.5	
132/33	Balance	6	4	1.55		0.5
132/34	Balance	6	4	1.55		

Therefore the second suggestion was that if diffusivity of Zr or Hf in the molten Ti is lower than those of Al or V, one might assume that they would accumulate in front of growing boride thus promoting the splitting of boride plates to needles (fibers). In fact, this effect was qualitatively detected in Scale 1 ingots (Fig. 7). Following the experiments with Scale 1 ingot, Scale 2 ingots Ti-6Al-4V-1.55B-0.5Zr was melted. However, no visible or measurable effects related to alloying with Zr were found in the Scale 2 ingots while comparing materials with or without Zr. It can be concluded that microalloying is to some extent effective only at high cooling rates (Scale 1). For this reason, alloying with Zr (Hf) can not be considered as a visible way to improve microstructure of Ti-6Al-4V alloys.

*Activity number and title*      *3.Determination of the thermomechanical processing and heat treatment conditions required to control and produce desired microstructure. Studying of the influence of different regimes of hot deformation and heat treatment on final microstructure and mechanical properties of Ti-6Al-4V/TiB eutectic alloys.*

This activity is being performed during the 2<sup>nd</sup> – 8<sup>th</sup> quarters. In the 3<sup>rd</sup> quarter Scale 3 ingot was thermomechanically processed. Main attention was paid to how nonuniform as-cast microstructure will change during deformation. Two surface zones (see Fig. 3 and 4) were removed by machining in order to minimize a variety of microstructures to two ones presented respectively on Fig 5 (a,b). Cylindrical green part 60 mm in diameter and 100 mm long from a bottom part of ingot was 3D forged into a cube 80x80x80 mm and then 1D

forged into a slab 130x100x20 mm. Thermomechanical processing was done in the  $\beta$ -field using regimes schematically presented in Fig. 8. The material exhibited good processability at these temperatures. The cylindrical green part and final slab are presented in Fig. 9. Microstructure of slab exhibited a significant refinement of the boride constituent as compared to the as-cast material. Typical microstructures after forging are presented in Fig. 10. As it is seen, the forging was not capable in making the microstructure uniform. Significant plastic flow produced wavy distribution of crushed borides but visible indications of degenerated zones remained (Fig. 10,b), contrary to that resulted from regular eutectic grains (Fig. 10,a). Further on, the slab was cut into bars 18x18 mm, part of which were unidirectionally rolled to 10x10 mm size, again fully in beta phase field. Further refine of boride particles to a average size of about 5  $\mu\text{m}$  resulted from rolling. Nevertheless, rolling by chosen regime did not lead to full structural homogeneity, as seen from Fig. 11, in which (a) and (b) present microstructures with formerly regular and degenerated as-cast microstructures.

Samples for tensile tests of as-cast and thermomechanically processed conditions were prepared. Mechanical tests are being performed. Preliminary results showed a brittle behaviour of as-cast material, while deformed material exhibited quite reasonable ductility. It should be concluded that unfortunately beta thermomechanical processing did not result in fully even microstructure. In future, combination of beta and alpha+beta processing will be used for this purpose.



Fig. 1. Three Scale 2 ingots before joining into consumable electrode.



Fig.2. Scale 3 ingot.

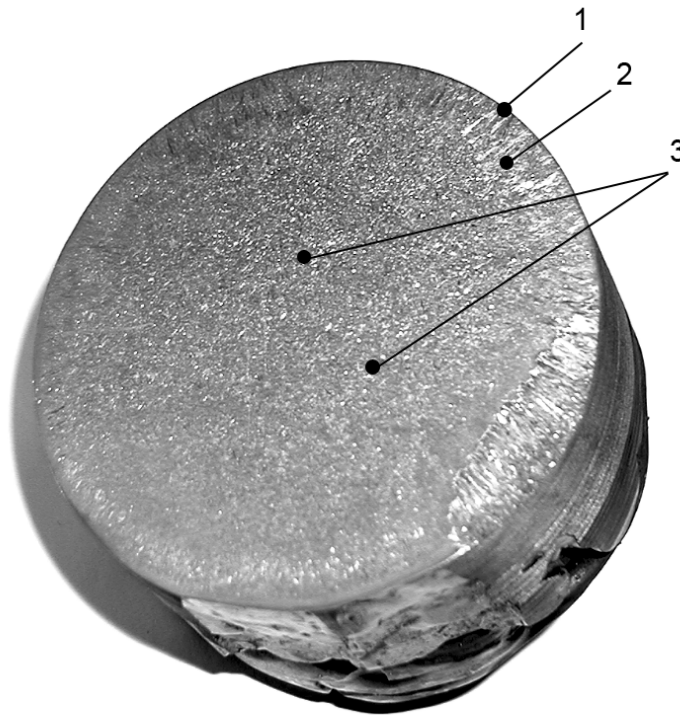

Fig.3. Transverse macrostructure of the Scale 3 ingot: 1 – the very surface zone with randomly oriented boride; 2 – the zone with oriented colony type eutectic structure; 3 – the zone with randomly oriented eutectic grains.

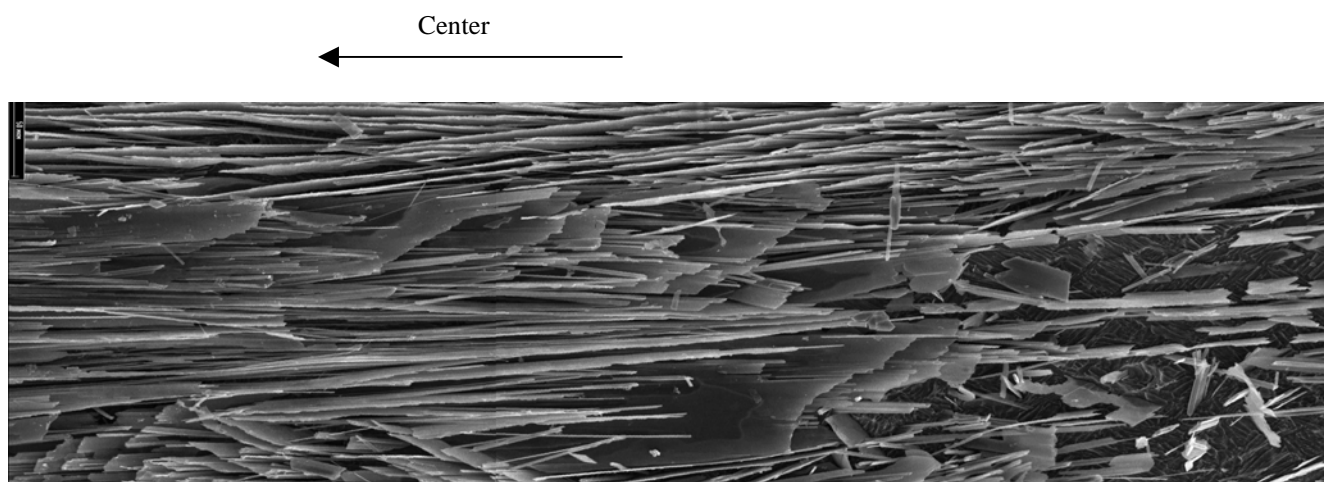
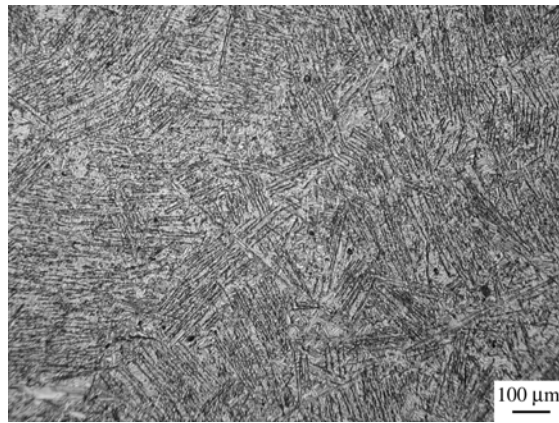

Fig. 4. Microstructure of area located between the first and second surface zones. SEM.



(a)



(b)

Fig. 5. Typical eutectic microstructures of the third zone: (a) – regular; (b) – degenerated. LM.

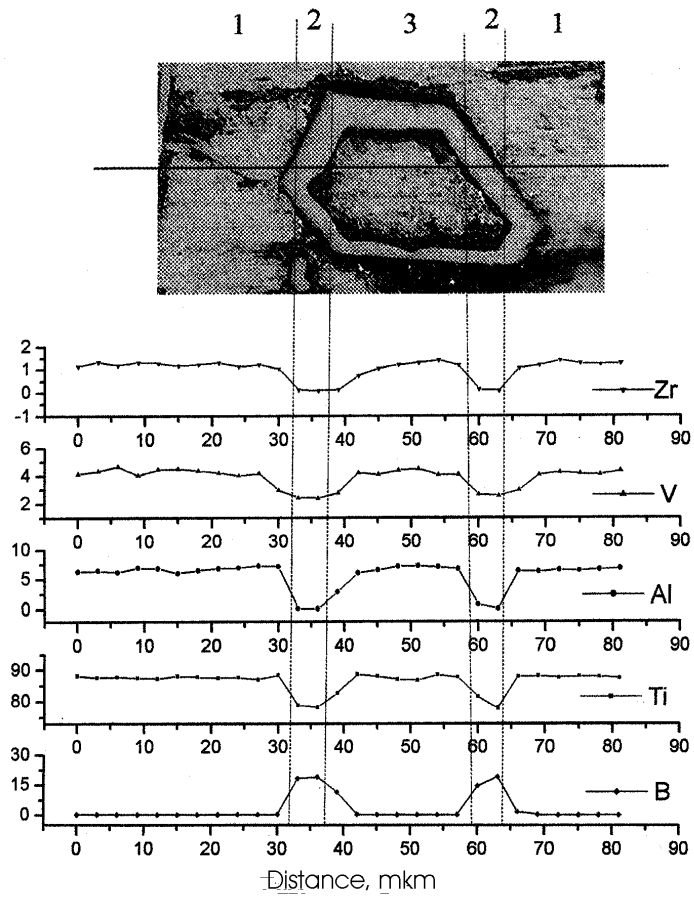
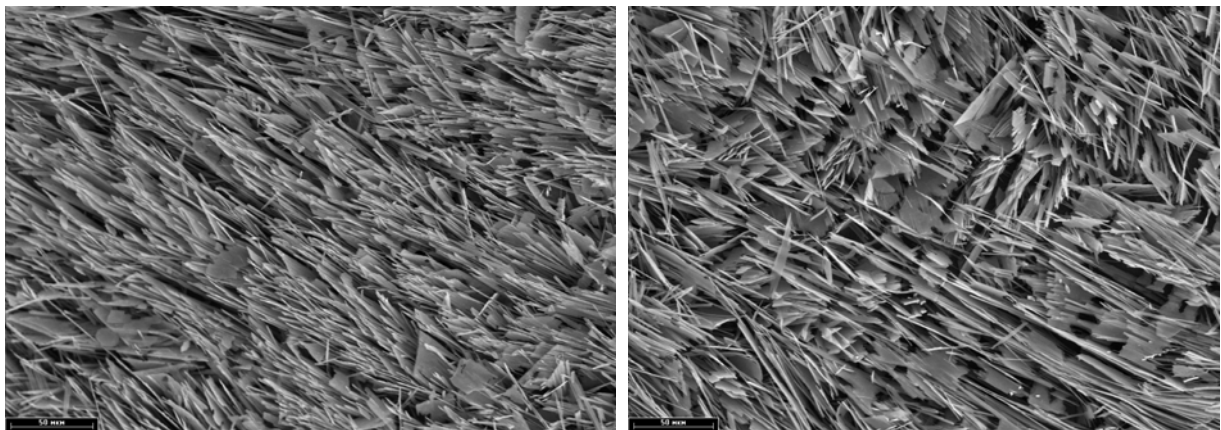

Fig. 6. Distribution of alloying elements between Ti matrix and primary boride crystal.



(a)

(b)

Fig. 7. Microstructure of Scale 1 ingots: (a) - Ti-64-1.55B-0.5Zr; (b) -Ti-64-1.55B.SEM.

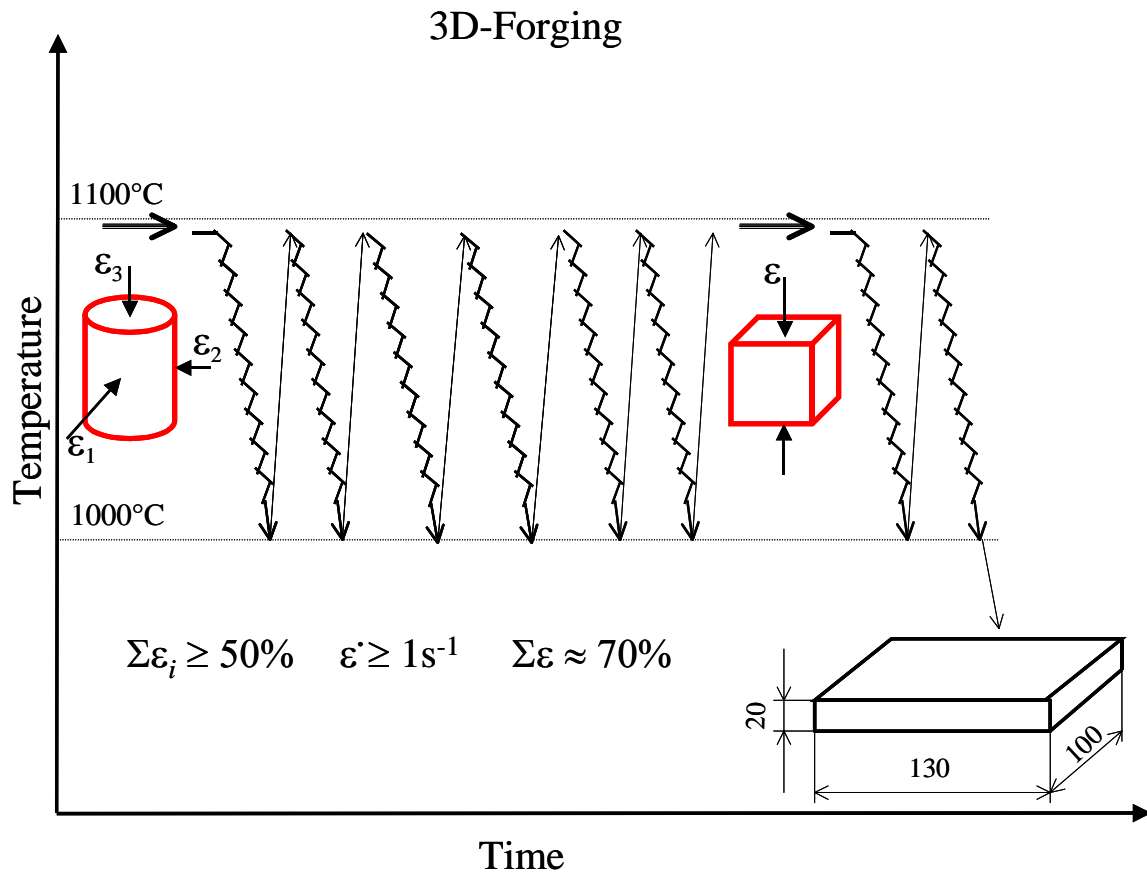

Fig. 8. Regime of forging.



(a)



(b)

Fig. 9. Cylindrical green part (a) and forged slab after surface machining (b).

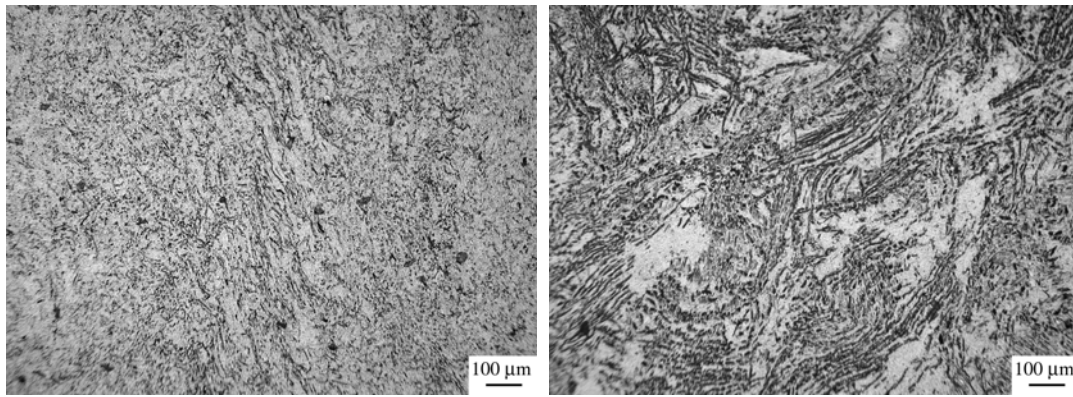

(a)

(b)

Fig. 10. Typical microstructures of forged slab: (a) - structure resulted from regular eutectic grains; (b) – structure resulted from degenerated zones. LM.

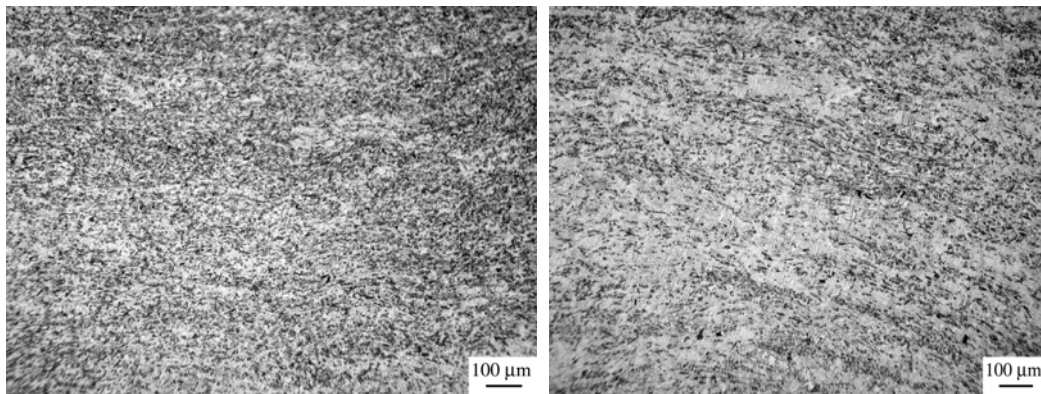

(a)

(b)

Fig. 11. Typical microstructures after additional rolling: (a) - structure resulted from regular eutectic grains; (b) – structure resulted from degenerated zones. LM.

## 2. Summary of personnel commitments.

Personnel FWS and NFWS were employed in accordance with Project Agreement with some correction of real working time. Participants were employed in the following activities:

<i>Participants</i>	<i>Activities</i>
Ivasishin	1, 3
Ivanchenko	1, 3
Teliovich	1, 3
Markovsky	1, 3
Garasym	1, 3
Pogrebnyak	1, 3
Savvakin	1, 3
Bondareva	1, 3
Levicka	1, 3

## 3. Description of business travel.

There were no business trips funded from P-132 project budget during the 3rd quarter. During his business trip to Melbourne (1597 project, attending "Low Cost Titanium" Symposium) Prof. Ivasishin met Dr. Miracle for discussions on current status of the P-132 project.

## 4. Current status.

Investigations and organizing works are being performed in accordance with the working schedule. It is agreed with Dr. Miracle that working plan for the second year should be modified, as mentioned above. Our suggestions on modified working plan and corresponding redirection of costs will follow soon.

## 5. Information about major equipment and materials acquired, other direct costs, related to the project..

During reporting quarter the following items were purchased and service were paid in accordance with working plan:

- materials: cutting tools (\$193), chemical goods (\$167), titanium and master alloys (\$ 890), stationery (\$91);
- other direct costs: charging of cylinders by inert gases (\$253), payment for service and repairing works on equipment (\$339), payment for computer service (\$640).

## 6. Delays, proposals.

See paragraph 4.

**Financial report for quarter 3` (agreed with financial officer) - is added**

*Project Manager*

*O.M.Ivasishin*

*Data: January 5, 2005*



**“ Ti-based metal matrix composites reinforced with TiB particles”**

*Project manager: Prof. O.M.Ivasishin*

*Tel: (044) 424-22-10, Fax (044)424-33-74, E-mail [ivas@imp.kiev.ua](mailto:ivas@imp.kiev.ua)*

*Kurdyumov Institute for Metal Physics NASU, Kyiv,*

*Project duration: 01 February 2004 – 31 March 2006*

*Financing countries: USA, EOARD*

*Reporting period: 01.01.2005-31.03.2005*

*Date of report presentation: 12.04.2005*

*Project code according to the Science and Technology Area: Primary: 3, 5; Secondary: 11, 13*

Content of report of project executing in Quarter 03

1. Short summary of progress	Q04 PAGE 1
2. Summary of personnel commitments	Q04 PAGE 14
3. Description of business travel	Q04 PAGE 15
4. Current status	Q04 PAGE 15
5. Overcome problems	Q04 PAGE 15
6. Delays and proposals	Q04 PAGE 15
Financial report for 04 quarter (agreed with financial officer) – attached	ActP132-04.s

### 1. Short summary of progress in Quarter 04

During the 3<sup>rd</sup> quarter, activities #1 and #3 were being performed.

<i>Activity number and title</i>	<i>1. Investigation of general influence of melt charge composition, melting regimes and subsequent solidification conditions on the microstructure (size and shape of basic crystals of eutectic grains, peculiarities of matrix phase) of alloys.</i>
<i>Works performing during the stage</i>	Structural homogeneity of Ti-64-B material melted from Ti-Al-V-TiB charge under different regimes of induction melting with portioned charge was additionally studied. The aim of these experiments was two-fold. First, some experiments on thermomechanical treatment are being done on induction melted Scale 2 ingots. Therefore, it was interesting to learn the relationship between structural homogeneity of as-cast and thermomechanically processed materials. Second, some mechanisms of formation of structural inhomogeneity can be reproduced in VAR Scale 3 ingots produced by remelting electrodes compacted from relatively coarse constituents. Of special interest was the case presented on Fig. 1 when distinctive layered structure was formed due to specific thermo-physical conditions in the melt pool resulting from next portion supply.

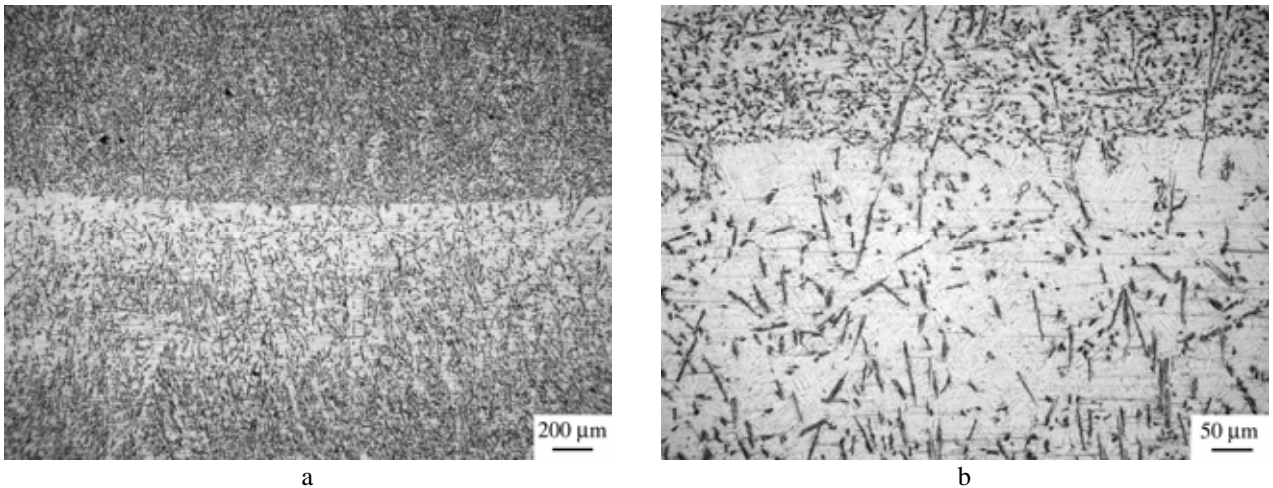

Fig.1. Microstructural inhomogeneity of second type.

*Activity number and title* 2. Producing of experimental ingot for subsequent thermomechanical processing and mechanical testing with arc- induction melting approach.

*Works performing during the stage* Modification of consumable electrode feeding and ingot drawing mechanisms of VAR furnace was done in order to increase length (weight) of Scale 3 ingots. Such design change allowed to use electrodes up to 600 mm long and to produce Ø70 mm ingots length up to 400 mm and total weight of above 7 kg. So far two ingots were melted (Fig. 2) for subsequent thermomechanical processing. The melting of new ingots is being continued.

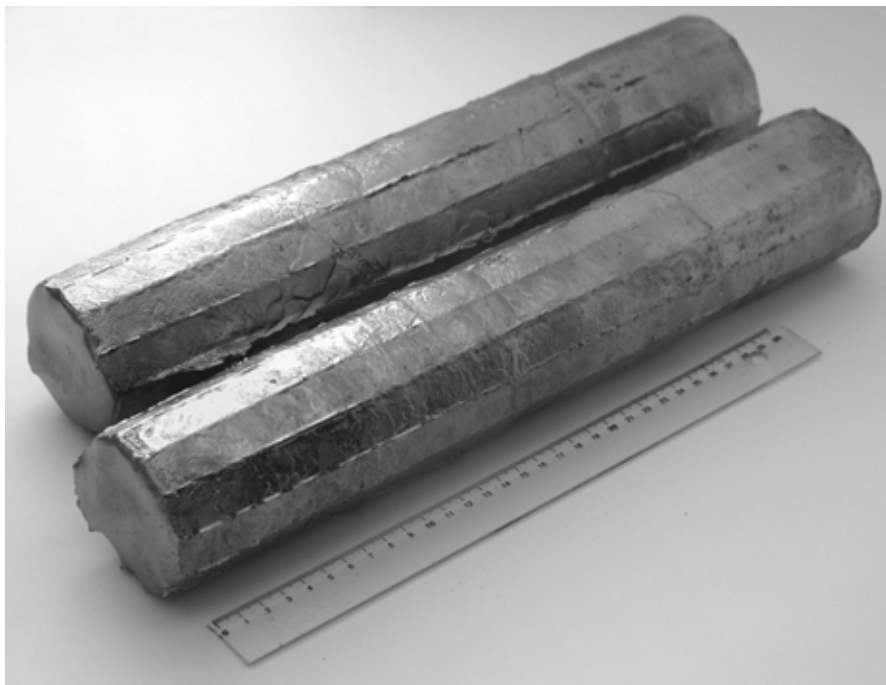

Fig. 2. Melted ingots.

*Activity number and title*      *3.Determination of the thermomechanical processing and heat treatment conditions required to control and produce desired microstructure. Studying of the influence of different regimes of hot deformation and heat treatment on final microstructure and mechanical properties of Ti-64-B eutectic alloys.*

### 3.1. Investigation of influence of hot deformation on microstructure of Ti-64-B.

Quantitative data on TiB morphology transformation at 2D-rolling of Scale 2 ingots under two rolling regimes, #1: at temperatures of single-phase beta field ( $T=1070\div 1000^{\circ}\text{C}$ )  $\varnothing 30\rightarrow\varnothing 12$  mm and #2: in  $\beta$  field ( $T=1070\div 1000^{\circ}\text{C}$ )  $\varnothing 30\rightarrow\varnothing 20$  mm and then in  $\alpha+\beta$  field ( $T=970\div 940^{\circ}\text{C}$ ),  $\varnothing 20\rightarrow\varnothing 10$  mm were received. Deformation rate was of about  $1\text{s}^{-1}$ , reduction degree per pass was of about  $\sim 20\%$ .

In as-cast condition ingot microstructure was coarse eutectic in which TiB crystals were up to 2-3  $\mu\text{m}$  thick and up to 60-70  $\mu\text{m}$  long (Fig. 3). Hot rolling via both regimes caused in essential refinement of TiB. Main changes related to TiB particle length, while their cross-section actually did not change (Figs. 4 - 6). Main difference between beta and  $\alpha+\beta$  processed microstructures was in different orientation of TiB relatively rolling direction and in different dispersion of  $\alpha$ -phase in matrix. After rolling in single-phase beta field (regime #1), only a slight trend in orientation of refined TiB particles along rolling direction was observed (Fig. 4) while rolling with regime #2 led to more uniform alignment of TiB particles (Fig. 5). The length of TiB particles did not exceed 10  $\mu\text{m}$ . However, even after rolling with regime #2 part of TiB particles were not oriented in rolling direction (Fig. 6). Rolling at temperatures of  $\alpha+\beta$  field caused in globularization of matrix alpha phase (Fig. 7).

Tensile properties (in rolling direction) after different regimes of rolling are listed in Table 1. These results show that better balance of strength and ductility was obtained after rolling with regime #2. Analysis of fracture surfaces allowed to suppose that the relatively low ductility of material was due to unfavorable orientation(transverse relatively to specimen axis) of TiB lamellae (Figs. 8-10).

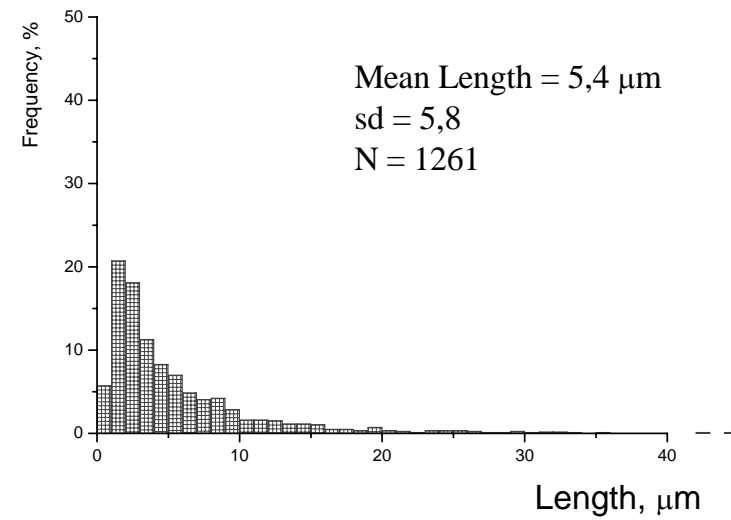
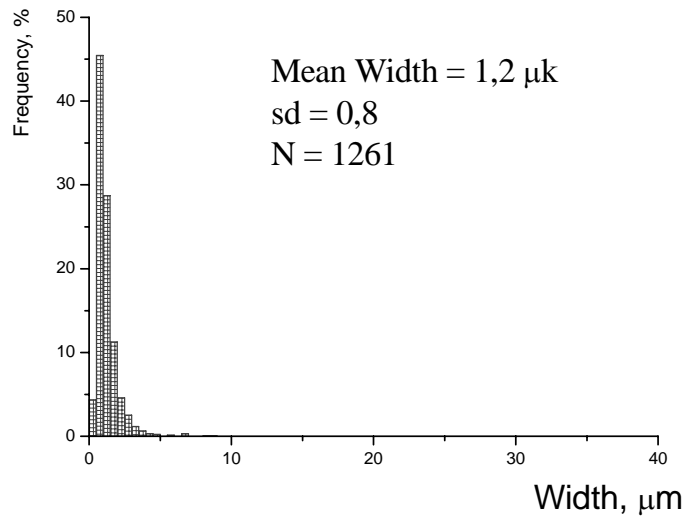
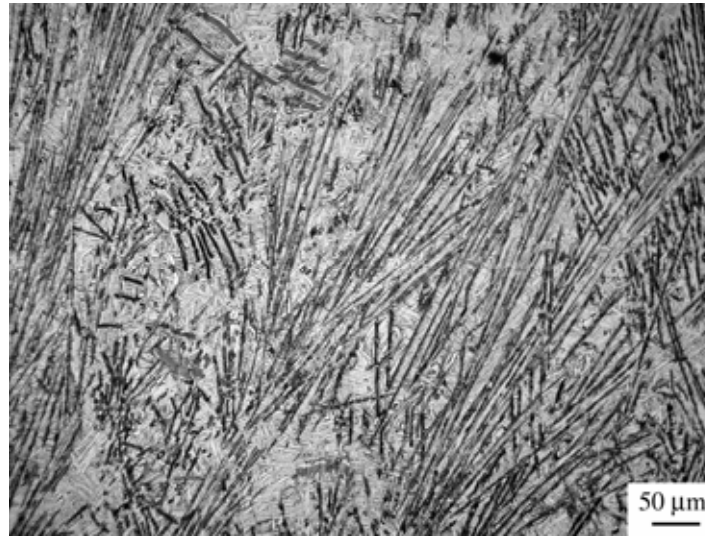
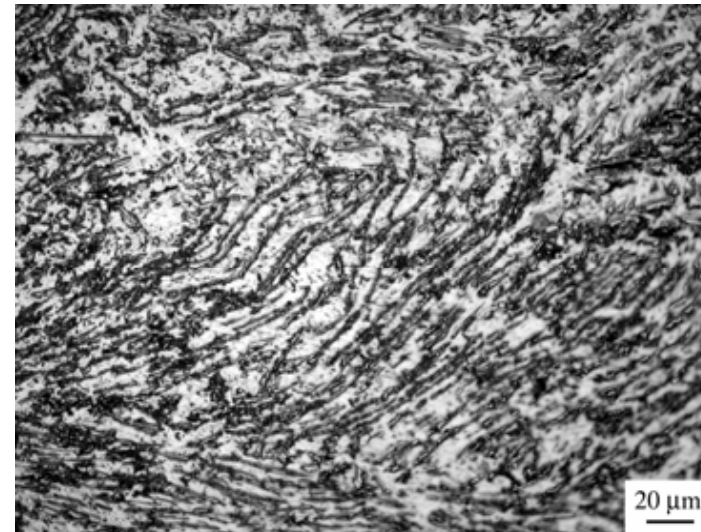
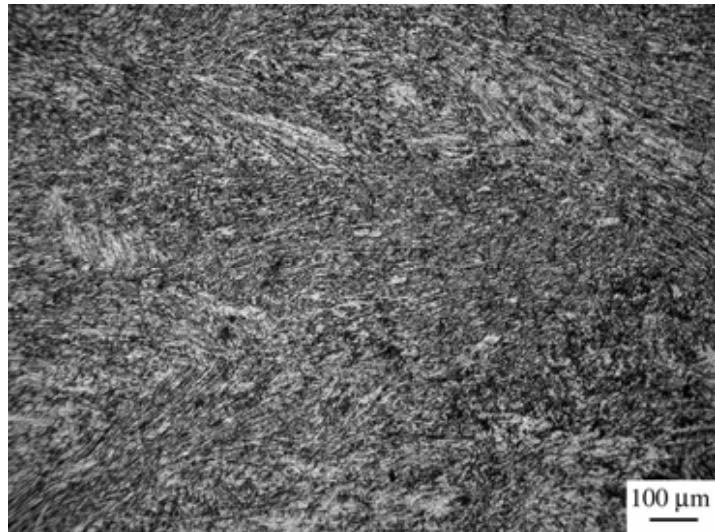

Fig. 3. Microstructure of as-cast alloy and frequency distribution of TiB particles in this material.



Rolling Direction  

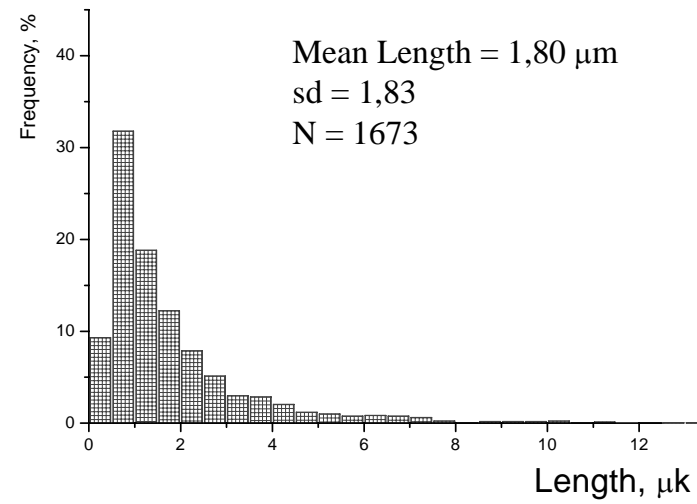
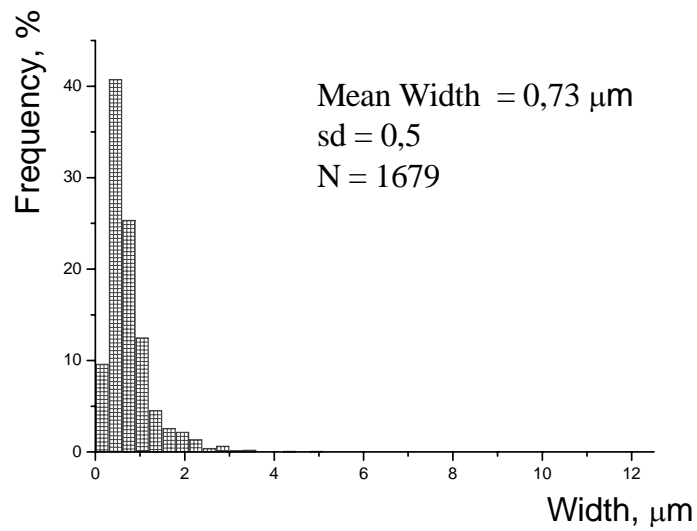



Fig.4. Microstructure of rolled (regime #1) alloy and distribution of TiB particles by sizes.



Rolling Direction

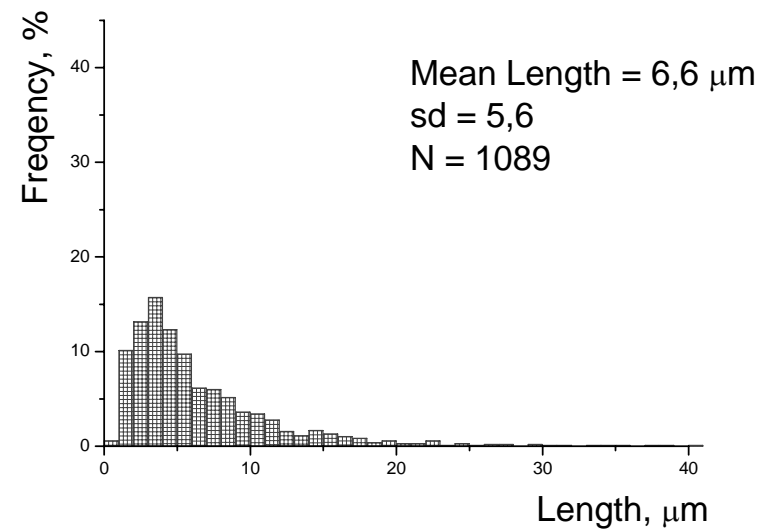
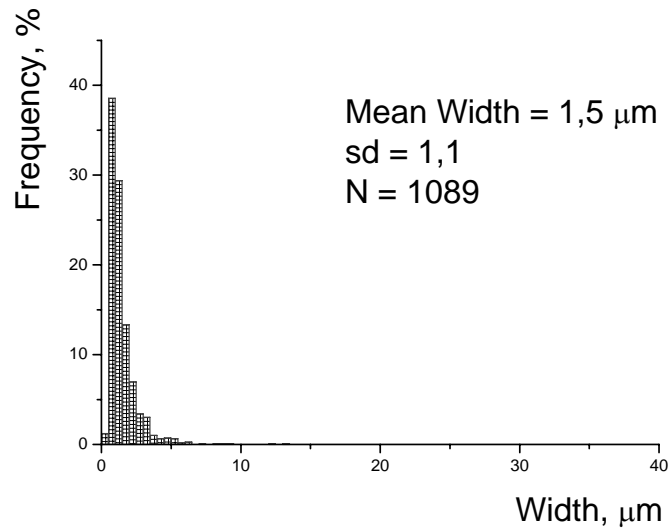

Fig. 5. Microstructure of rolled (regime #2) alloy and distribution of TiB particles by sizes.

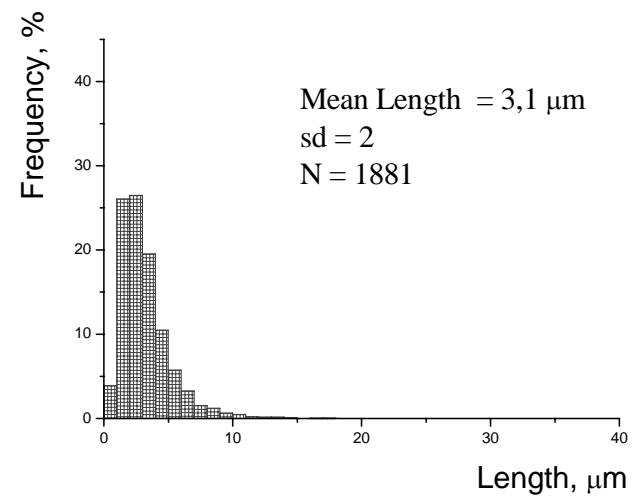
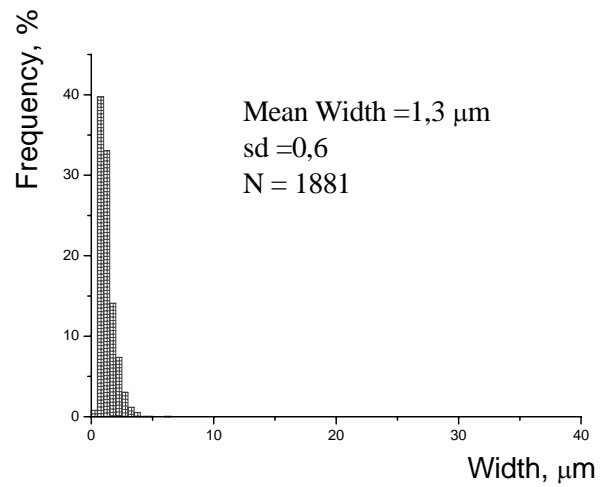
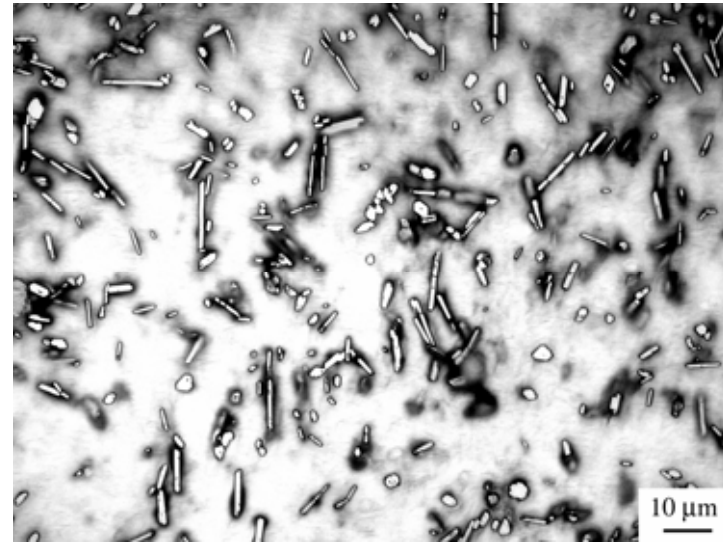
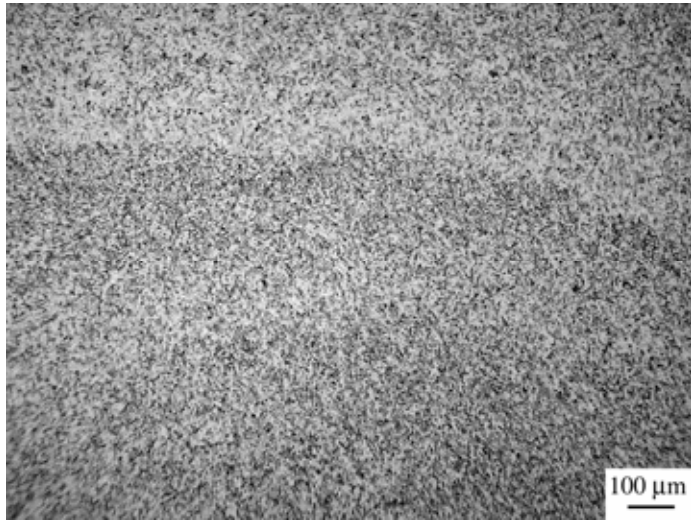

Fig. 6. Microstructure of rolled (regime #2) alloy and distribution of TiB particles by sizes. Cross-section plane.

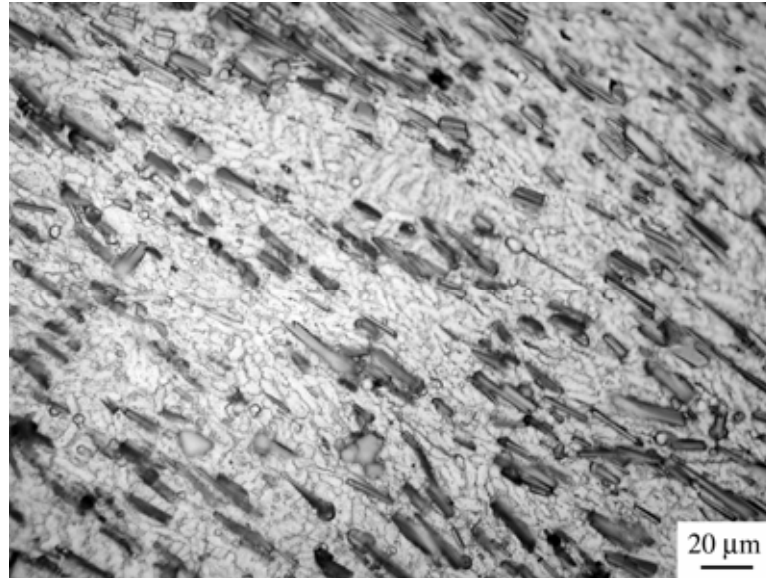

Fig. 7. Equiaxed microstructure after rolling (regime # 2).

Table 1.

Tensile Properties of Ti-6-4-1.55 B

Treatment	Specimens' #	Properties			
		YS, MPa	UTS, MPa	El, %	RA, %
1. As-cast Ø30 mm ingot	1.1	below YS	-	0.04	-
	1.2	below YS	-	0.08	-
2. Ø 30 mm ingot + rolling: Ø30 to Ø12 mm (1070-1000°C)	2.1	1104	1199	3.79	23.00
	2.2	1057	1170	4.53	20.67
	2.3	1090	1190	3.25	21.15
	2.4	1114	1209	1.61	25.20
	2.5	1178	1252	1.74	10.96
3. Ø30 mm ingot+ rolling: Ø30 to 20 mm (at 1070-1000°C), + 20 to Ø10 mm (at 970-940°C)	3.1	1219	1367	5.27	25.94
	3.2	1182	1356	4.37	25.84
	3.3	1247	1382	4.38	22.57
	3.4	1220	1352	3.62	22.56

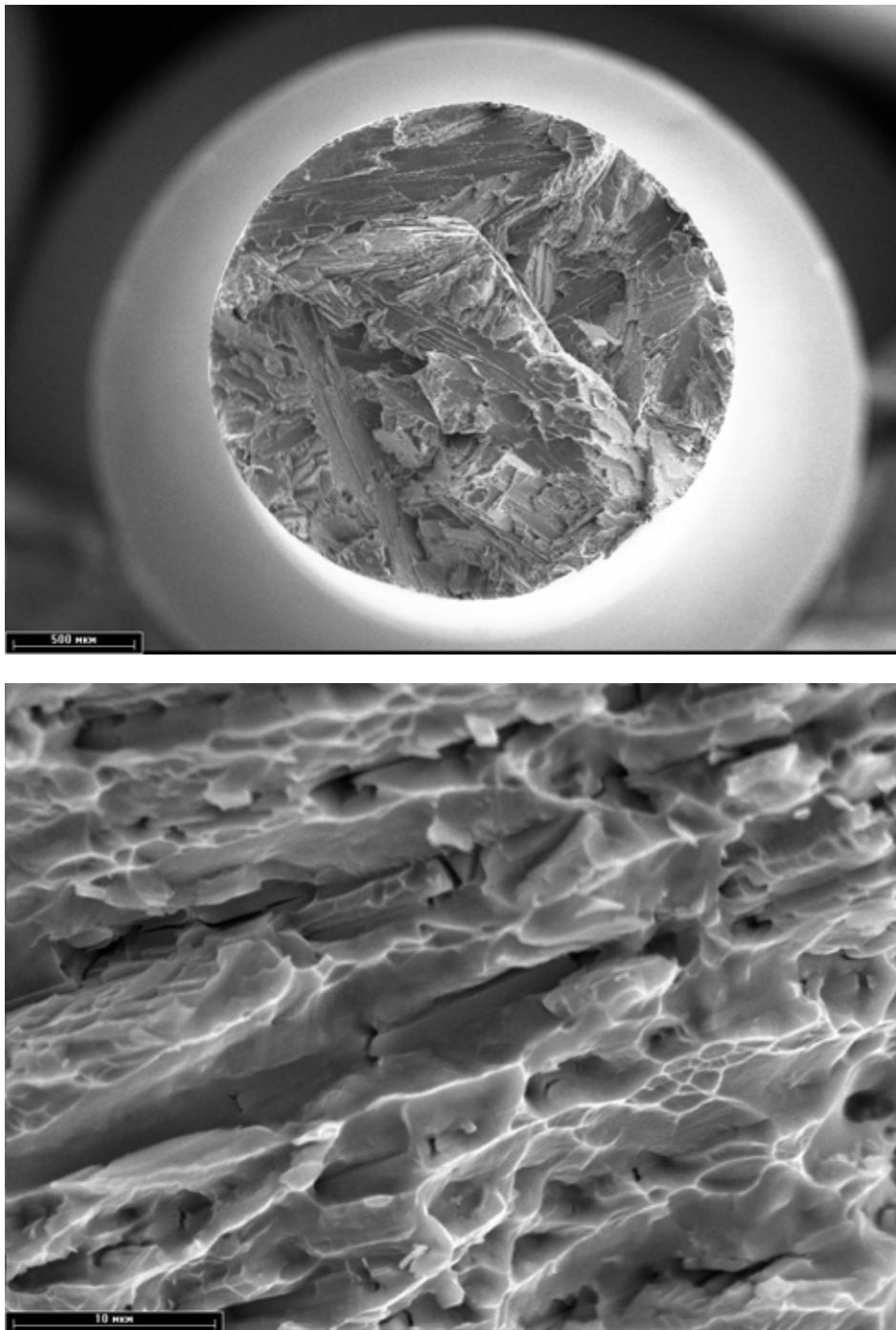

Fig. 8. Fracture surface of 1.1 specimen (as-cast condition).

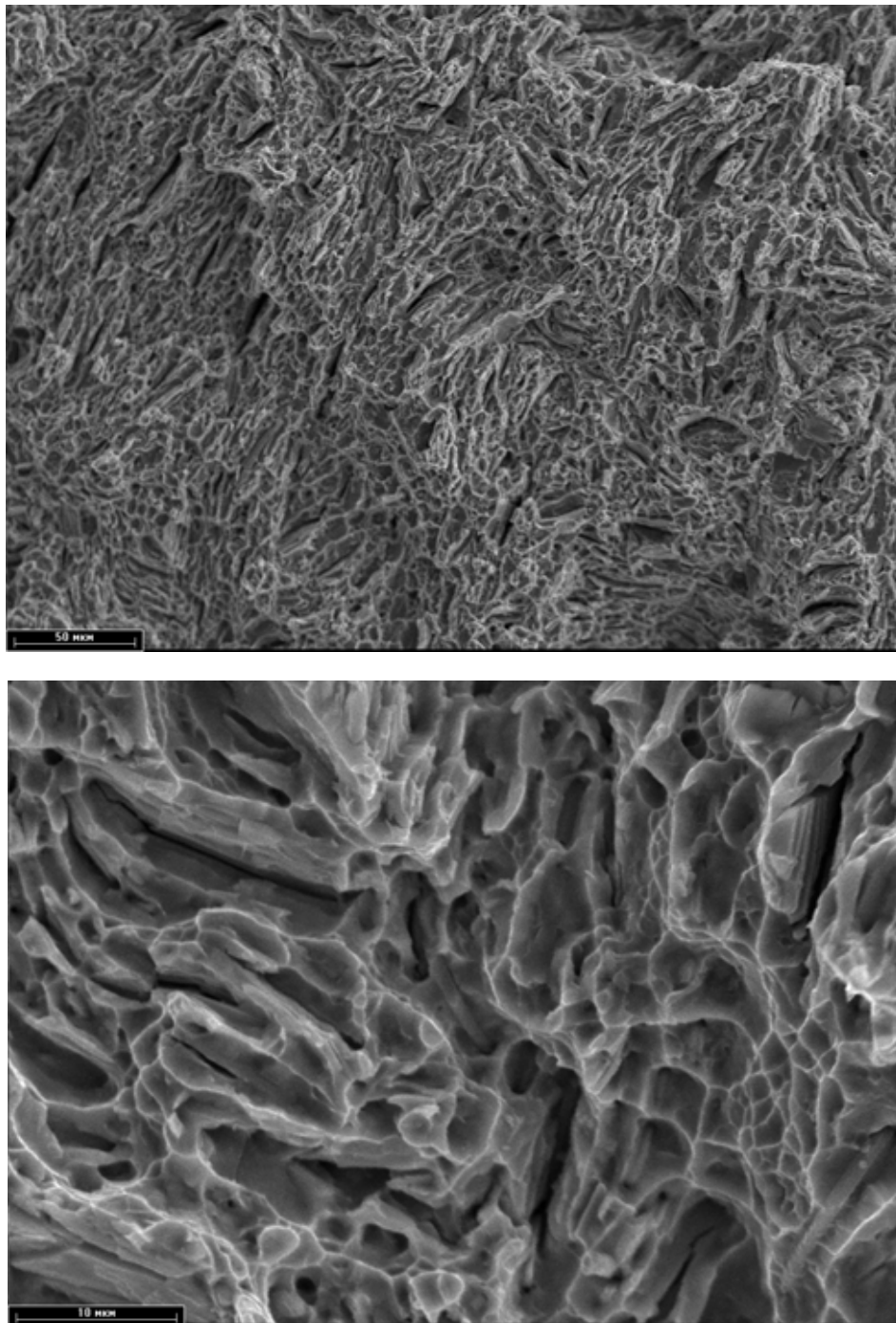

Fig. 9. Fracture surface of 2.5 specimen ( $\beta$ -rolled condition).

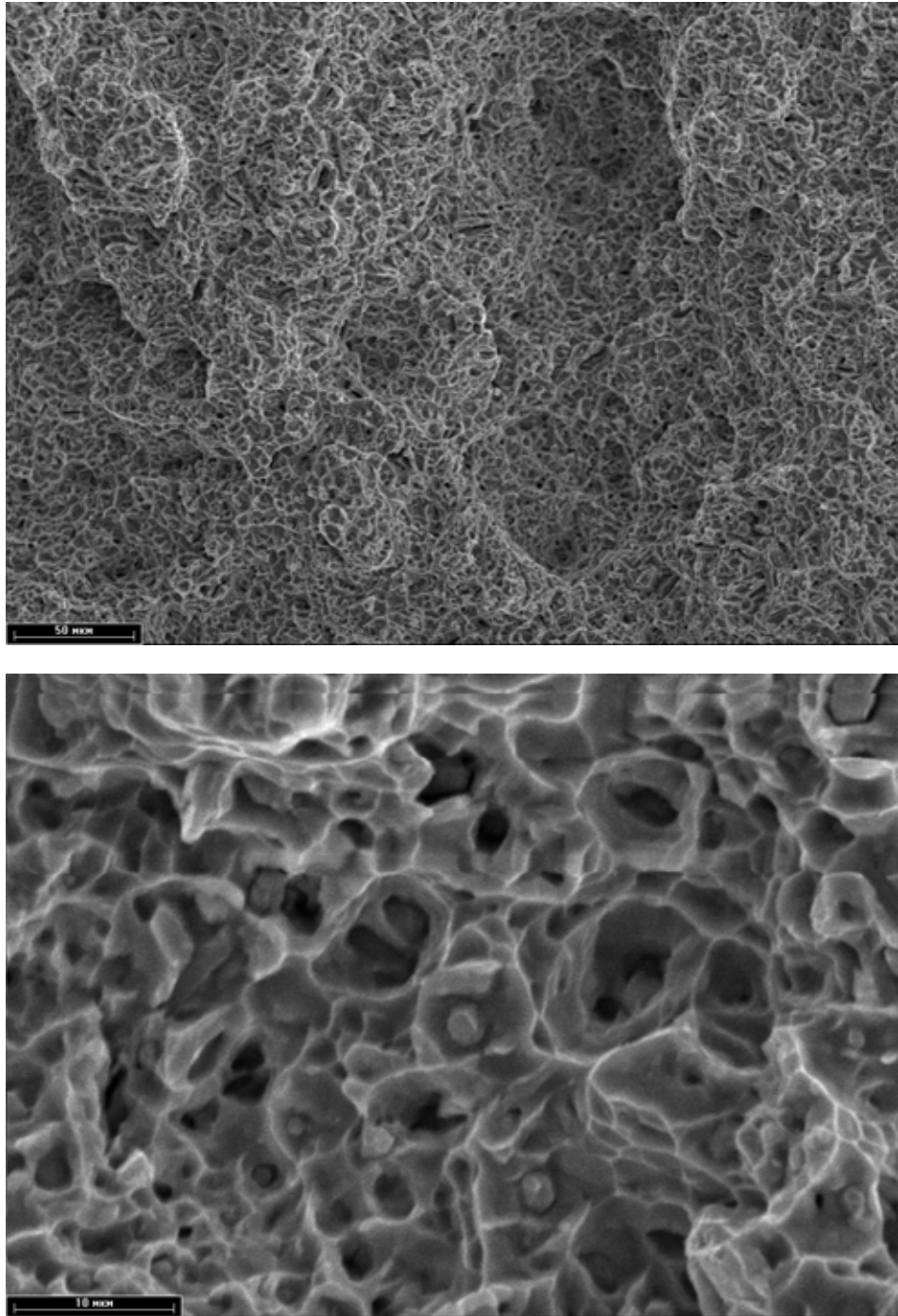

Fig. 10. Fracture surface of 3.4 specimen ( $\alpha+\beta$ -rolled condition).

The value of TiB compound elastic modulus was estimated. It was found to be 446 GPa, i.e. much closer to 482 GPa value determined in [1] than to 371 GPa value determined in [2]. Then using Halpin-Tsai equation [3] concentration dependences of modulus for randomly oriented (Fig. 11) and unidirectional oriented (Fig. 12) microstructures were predicted and compared with available in literature and own measurements. For as-cast and 3D forged (randomly oriented) microstructures E was found to be 132 GPa and 129 GPa, correspondingly. For 2D rolled in  $\alpha+\beta$  field (unidirectional oriented) microstructure E found from two measurement was 134 GPa. It should be mentioned that aspect ratio was rather low ( $\sim 2.5$ ) what makes predictions not very accurate.

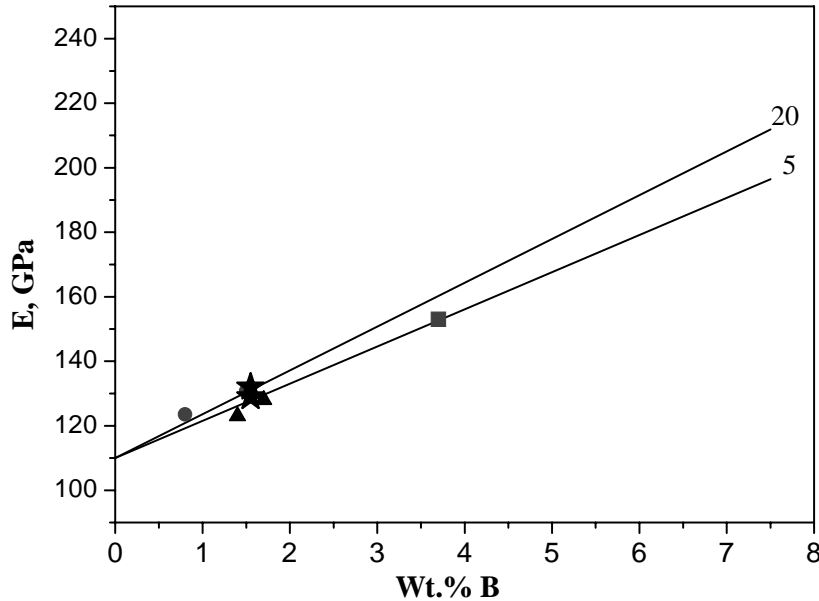

Fig.11. Elastic modulus of randomly oriented fiber composites Ti-64-B. Solid lines present the results of calculations for 5 and 20 aspect ratio. Symbols present the experimental results: ■ – [1], ▲ – [4], ● – [5], \* - our results.

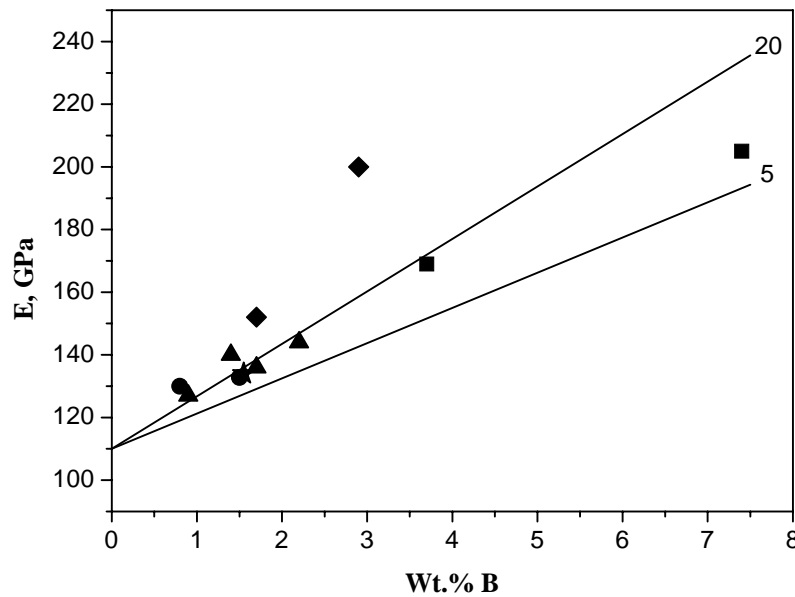

Fig.12. Elastic modulus of unidirectional oriented fiber composites Ti-64-B. Solid lines present the results of calculations. Symbols present experimental results: ■ – [2], ▲ – [4], ● – [5], ◆ - [6], \* - our results.

### 3.2. Influence of heat treatment on microstructure of Ti-64-B eutectic alloy.

Quantitative data on influence of high-temperature annealing on microstructure of Ti-64-1.55B were received. Material rolled with regime #1 was annealed during 10h at temperatures 1150, 1250, and 1350°C. Resulting microstructures are shown on Fig. 13. Results are summarized on Fig. 14. Increase in size of TiB particles was observed even after annealing at 1150°C. No visible change in aspect ratio was observed after annealings. Such experiments will be continued for materials rolled via other regimes.

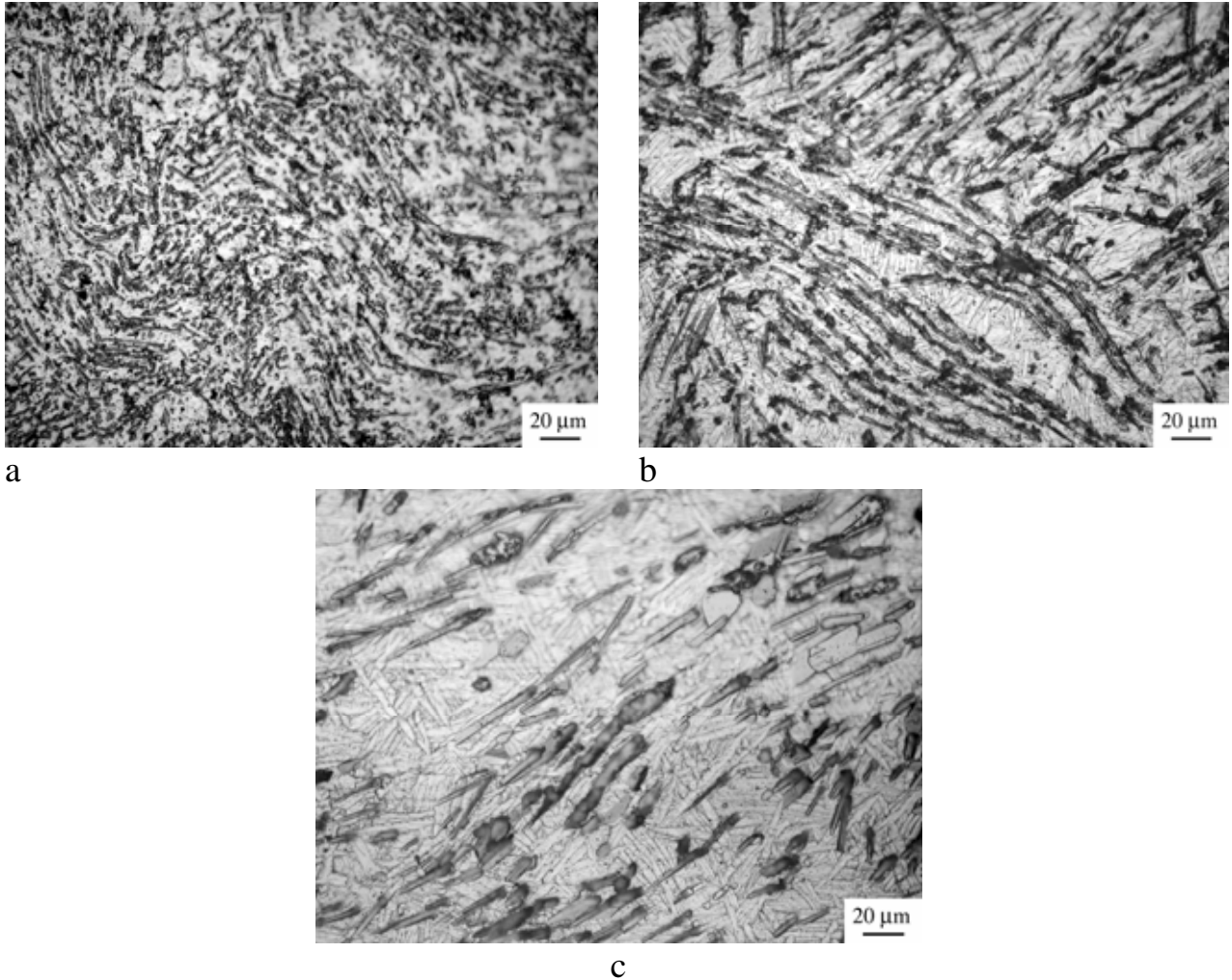

Fig. 13. Microstructures of rolled with regime #1 alloy in (a) initial rolled condition and after annealing: (b) – 1150°C, 10h, (c) - 1350°C, 10h.

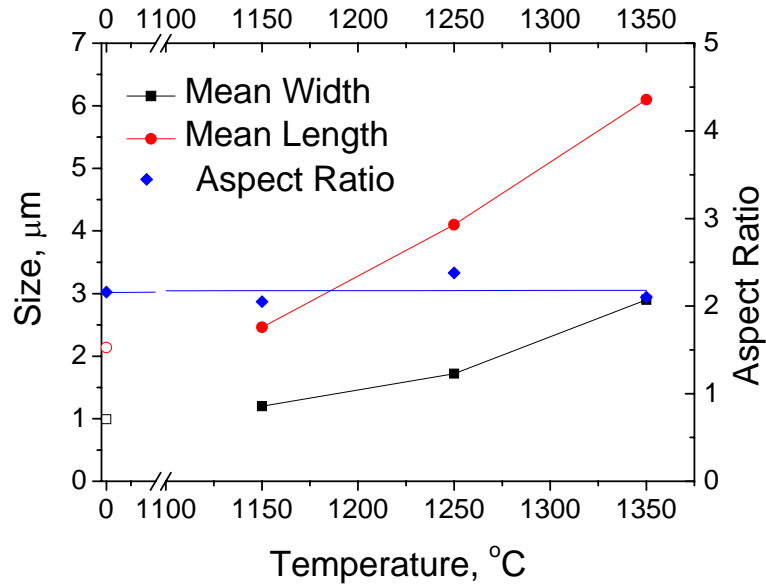

Fig.14. Influence of annealing temperature on mean dimensions of TiB particles in rolled with regime #1 material. Open symbols – initial rolled condition; solid symbols – annealed conditions.

*References:*

- [1]. S. Gorse, D.B. Miracle, "Mechanical properties of Ti-6Al-4V/TiB composites with randomly oriented and aligned TiB reinforcement". Acta Materialia, v.51, No9 (2003) p.2427-2442
- [2]. R.R. Atri, K.S. Ravichandran, S.K. Jha, "Elastic Properties of in-situ Processed Ti-TiB Composites Measured by Impulse Excitation of Vibration", Materials Science and Engineering, A271, 1999, p. 150-159.
- [3]. P.K.Mallick. Fiber reinforced composites: Materials manufacturing and design, Marcel Dekker, New York, 1988, p.111
- [4]. C.F. Yolton, J.H. Moll, "Evaluation of a Discontinuously Reinforced Ti-6Al-4V Composite", Titanium'95: Science and Technology, P.A.Blenkinsop, W.J. Evans, H.M. Flower (Eds.), The Institute of Materials, London, UK, 1996, p. 2755-2762.
- [5]. Z. Fan, L. Chandrasekaran, C.M. Ward-Close, A.P. Miodownik, "The Effect of Pre-Consolidated Heat Treatment on TiB Morphology and Mechanical Properties of Rapidly Solidified Ti-6Al-4V-xB Alloys", Scripta Metallurg. Mater. V. 32, No. 6, 1995, p. 833-838.
- [6]. R.B. Bhat, S. Tamirisa, D.J. McEldowney, D.B. Miracle, "Effect of Processing on the Microstructure and Properties of Ti-6Al-4V-xB Alloys", MS&T, Affordable Metal Matrix Composites for High Performance Applications II, 2003, p.115-124.

**2. Summary of personnel commitments.**

Personnel FWS and NFWS were employed in accordance with Project Agreement with some correction of real working time. Participants were employed in the following activities:

<i>Participants</i>	<i>Activities</i>
Ivasishin	1, 2, 3
Ivanchenko	1, 2
Teliovich	1, 3
Markovsky	1, 3
Garasym	1, 3
Pogrebnyak	1, 3

Savvakin	1, 3
Bondareva	1, 3
Levicka	1, 2
Pischak	2, 3
Molyar	2, 3
Mel'nik	1, 2

**3. Description of business travel.**

There were no business trips funded from P-132 project budget during the 4 rd quarter.

**4. Current status.**

Investigations and organizing works are being performed in accordance with the working schedule.

**5. Information about major equipment and materials acquired, other direct costs, related to the project..**

During reporting quarter the following items were purchased and service were paid in accordance with working plan:

- materials: stationery (\$227), cartridges (\$193), titanium sponge (\$2038), Argon (\$109), chemical (\$57);
- other direct costs: Payment for different services (repairing of printers - \$137, computer service - \$317, equipment repair -\$424).

**6. Delays, proposals.**

No.

**Financial report for quarter 4 (agreed with financial officer) - is added**

*Project Manager*

*O.M.Ivasishin*

*Data: April 12, 2005*

**“ Ti-based metal matrix composites reinforced with TiB particles”**

*Project manager: Prof. O.M.Ivasishin*

*Tel: (044) 424-22-10, Fax (044)424-33-74, E-mail [ivas@imp.kiev.ua](mailto:ivas@imp.kiev.ua)*

*Kurdyumov Institute for Metal Physics NASU, Kyiv,*

*Project duration: 01 February 2004 – 31 March 2006*

*Financing countries: USA, EOARD*

*Reporting period: 01.04.2005-30.06.2005*

*Date of report presentation: 15.07.2005*

*Project code according to the Science and Technology Area: Primary: 3, 5; Secondary: 11, 13*

Content of report of project executing in Quarter 03

1. Short summary of progress	Q05PAGE 1
2. Summary of personnel commitments	Q05PAGE 11
3. Description of business travel	Q05PAGE 11
4. Current status	Q05PAGE 11
5. Overcome problems	Q05PAGE 11
6. Delays and proposals	Q05PAGE 11
Financial report for 05quarter (agreed with financial officer) – attached	ActP132-05s

### 1. Short summary of progress in Quarter 05

During the 3<sup>rd</sup> quarter, activities #2 and #3 were being performed.

*Activity number and title*      2. *Producing of experimental ingot for subsequent thermomechanical processing and mechanical testing with arc- induction melting approach.*

*Works performing during the stage*      As it was shown earlier with Scale 2 ingots (See Q3 Progress Report), the macrostructure and microstructure of Ti64-B ingots are strongly dependant on the cooling rate and the temperature gradient that caused in formation of a remarkable non-uniformity through longitudinal and transverse sections.

It was found that such variation in structure even increased in larger Scale 3 ingot.

The structural nonuniformity in Scale 3 ingots can be summarized as follows:

1) Macrostructure can be of equiaxed or columnar type; in the last case columnar grains are oriented along temperature gradient;

2) Each grain, either equiaxed or columnar, consists of TiB plates or fibers and matrix of close to Ti-6Al-4V composition.

In equiaxed grains, in the medium range of the cooling rate, TiB and matrix are organized as colonies. At very fast (the very rim of the ingot) or very slow (the central part of the ingot) cooling the structure is not of a colony type, it looks rather as a conglomerate of two separate phases, not united by a cooperative growth.

Of a special interest is an intermediate type of microstructure (degenerated eutectic), which is a mixture of regular eutectic and a relatively coarse TiB crystals

with boride-free zones around them (Fig. 1).

3) In equiaxed grains there is no preferred orientation of TiB plates (fibers), they are randomly oriented, while in columnar grains TiB crystals are aligned along the grains.

4) Within each microstructural form, dispersivity (fineness) of the structure is increasing with a cooling rate increase.

5) Dispersivity of  $\alpha+\beta$  matrix is defined by distance between neighboring crystals of TiB; in degenerated eutectic matrix around coarse borides is always coarser as compared to regular eutectic.

The experiments performed during 5<sup>th</sup> Quarter showed that the VAIR technology allows to widely affect the ingot macrostructure (Fig.2). In a pure VAR process the change of the arc power leads only to the change of the liquid pool depth, while in VAIR, changing the ratio between arc and inductor powers may cause in the change in melt pool geometry thus influencing the directionality of macrostructure and microstructure. It is well understood that with nearly flat solid-melt interface directionality of structure will be the same through the ingot cross-section while having arc-like interface leads to the directionality changing from horizontal in peripheral to vertical in central parts of ingot.

Taking into account a mass balance under conditions of the constant rate of the ingot pulling out the rate of ingot solidification  $R$  ( $dm_{\text{ingot}}/dt$ ), will be proportional to the melting rate of consumable electrode ( $dm_{\text{electrode}}/dt$ ), i.e.  $R=f(W_1)$ , where  $W_1$  is arc power.

On the other hand, temperature gradient  $G$  is defined by both  $W_1$  and  $W_2$  ( $W_2$  is power of inductor). Thus, changing the ratio between arc and induction powers will change the ratio between  $R$  and  $G$  – two parameters defining the ingot microstructure. Low  $R$  (and high  $G$ ) promotes columnar type microstructure, while high  $R$  and low  $G$  – equiaxed type microstructure. With this in mind, several runs were done with various  $W_1 / W_2$  ratio what resulted in different macrostructure of ingots (Fig. 3). When the arc was switched off (end of melting) the zone with equiaxed microstructure was formed in upper part of both ingots.

Two examples of microstructure are presented in Fig.4 in their relation to the ingot axis. First, in which borides are aligned, corresponds to columnar grains oriented along the ingot axis; second, with random orientation of borides – to equiaxed grains.

Crystallography of both eutectics was studied with XRD analysis. Cubic specimens 14x14x14 mm were cut out of corresponding parts of ingots. One of the cube axis was oriented parallel to longitudinal ingot axis. It was found that directionality in macro/microstructure goes along with a crystallization texture.

Pole figures of alpha- and TiB phases are shown in Fig. 5 for aligned eutectic like that in Fig.4a. It is clearly seen that TiB crystals have [020] direction parallel to the ingot axis (direction of solidification) forming axial texture (some deviation from ingot axis may be explained by inaccuracy of specimen cutting). Alpha- phase crystals also form rather sharp ring-shaped  $\langle 100 \rangle$  texture (or (002) texture that is equivalent).

For microstructure presented in Fig. 4b there is no preferable crystallographic orientations of any phases (Fig. 6).

Formation of solidification texture in aligned eutectic can be explained as following. It was established in [1] that upon formation of columnar type macrostructure in Ti64 alloy the beta-phase has a pronounced  $\langle 100 \rangle$  axial texture (Fig. 7). It is quite reasonable to assume that solidification texture of beta-phase in Ti64-TiB eutectic is of the same type.

Hence, texture of  $\alpha$ -phase comes from the  $\beta$ -phase texture and subsequent realization on  $\beta \rightarrow \alpha$  transformation obeyed to Burgers Orientation Relationship (OR), although not all possible OR variants seems to be realized. Theoretical pole figure for  $\alpha$ -phase built up from above mentioned assumptions is presented on Fig.6c. It coincides with experimental pole figure if number of Burgers OR variants is reduced to 4. Those variants are realized which have basic (0002)  $\alpha$ -phase perpendicular to plane  $[100] \beta \parallel [020] \text{TiB}$ .

From data obtained, it is possible to draw most probable crystallographic model of eutectic couple  $\beta$  - TiB (Fig. 8). Both phases have interface  $(200)\text{TiB} \parallel (011,0-11) \beta$ , and parallel directions  $[020]\text{TiB}$  and  $[100] \beta$ . Eutectic couple as a whole may occupy any space position as a result of rotation around axis  $(020)\text{TiB} \parallel (100) \beta$ . Formation of such kind of interface during solidification may be determined by a tendency to minimize the surface energy since just in these planes both phases have very close configuration in location of Ti atoms with minimal difference in interatomic spacing (Fig. 9). These crystallographic features of interface promote a selection of Burgers OR variants on beta to alpha transformation.

Another possibility in this model may be realized if phases have interface  $(102) \text{TiB} \parallel (011, 0-11) \beta$ .

Elastic modulus in aligned eutectic measured with Ultrasonic method was found to be 138 GPa and 127 GPa in longitudinal and transverse directions respectively, whereas in random eutectic modulus was the same in both direction - 134 GPa.

*Activity number and title*      *3.Determination of the thermomechanical processing and heat treatment conditions required to control and produce desired microstructure. Studying of the influence of different regimes of hot deformation and heat treatment on final microstructure and mechanical properties of Ti64B eutectic alloys.*

*Works performing during the stage*      During the 5<sup>th</sup> quarter works on thermomechanical processing was continued using  $\emptyset$  70 mm ingots, which had no solidification texture. This treatment included: 3D forging in single-phase beta field (1100°C) followed by rolling in  $\alpha+\beta$  field (960°C) into rod  $\emptyset$  12 mm.

It is necessary to underline that in degenerated eutectic type microstructure remains visible after forging (Fig. 10a) and even after subsequent rolling (Fig.10b). TiB particles are distributed in microstructure nonuniformly. Locations around previous coarse TiB crystals remain boride-free. Due to that, matrix in these locations is coarse even after heavy thermomechanical processing.

Rolled material had following tensile properties: YS= 1170 MPa, UTS=1230 MPa, El.=6.0%, RA=20.7%.

Creep behavior of Ti64-1.55B alloy in both as-cast, and forged conditions in comparison with conventional as-cast Ti-6Al-4V was studied (Fig.11). Comparison of creep data is shown in Fig. 12. It is clear seen that material reinforced by TiB particles has essentially higher characteristics (plastic strain, exponent coefficient n) at equal loads. Forged condition has an advantage over the as-cast condition at loads below 450 MPa, but it becomes less creep resistant at higher loads.

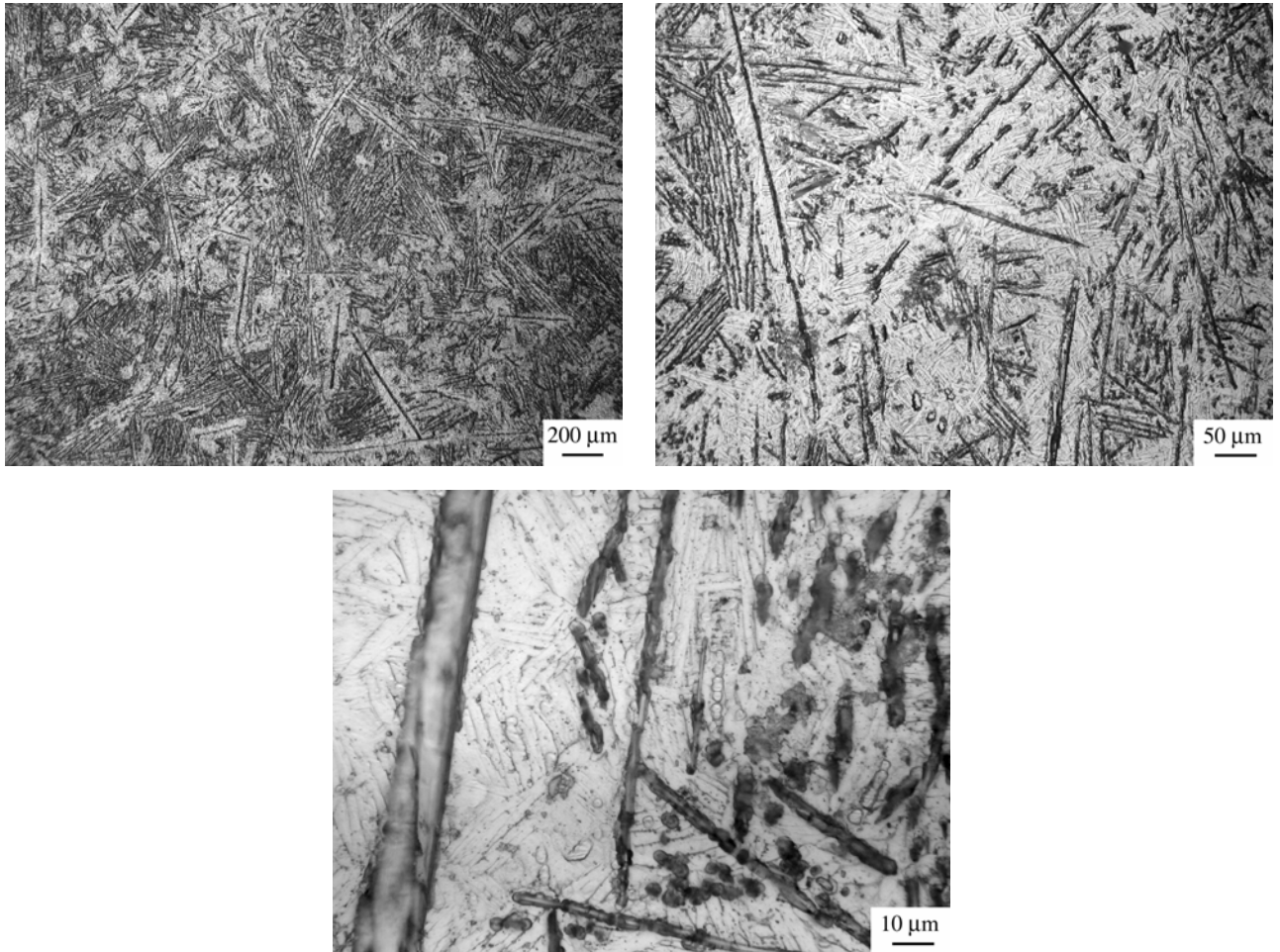

Fig.1. Typical example of “degenerated” Ti64-1.55B eutectic.

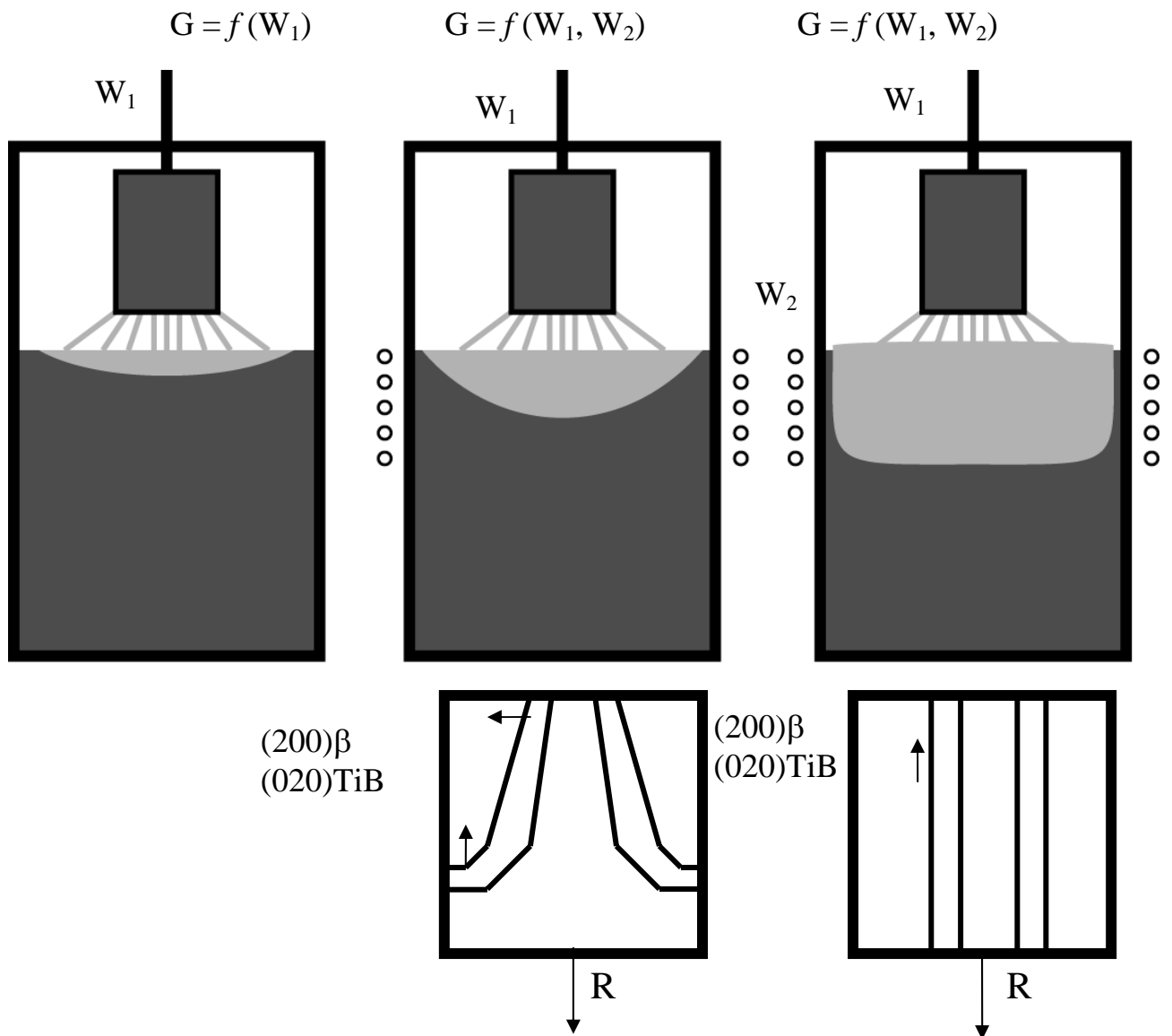

Fig. 2. Influence of melting mode on melt pool and solidification macrostructure (scheme).

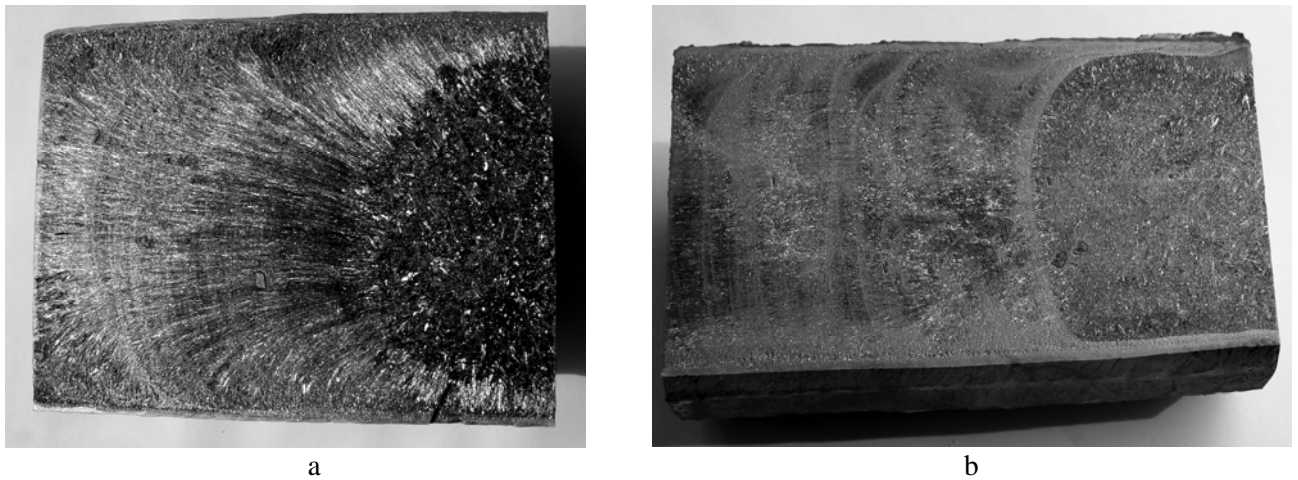

Fig. 3. The influence of power ratio on the form of melt pool: (a)  $W_1 = 9$  kWA,  $W_2 = 40$  kWA,  $R=3$  mm/min; (b)  $W_1 = 6$  kWA,  $W_2 = 50$  kWA,  $R=2$  mm/min

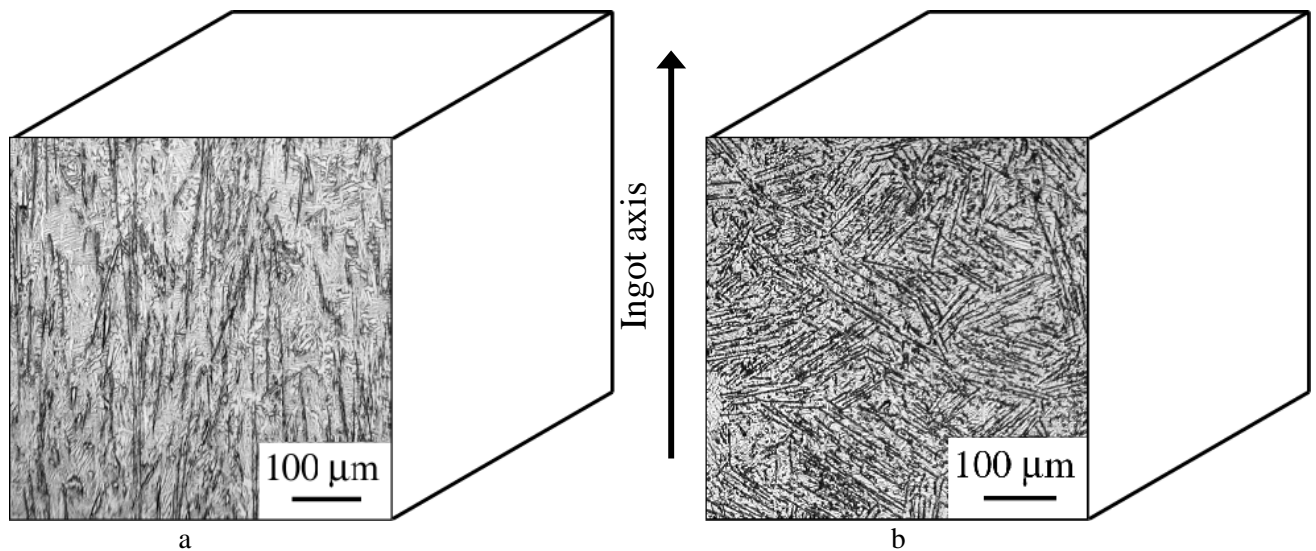
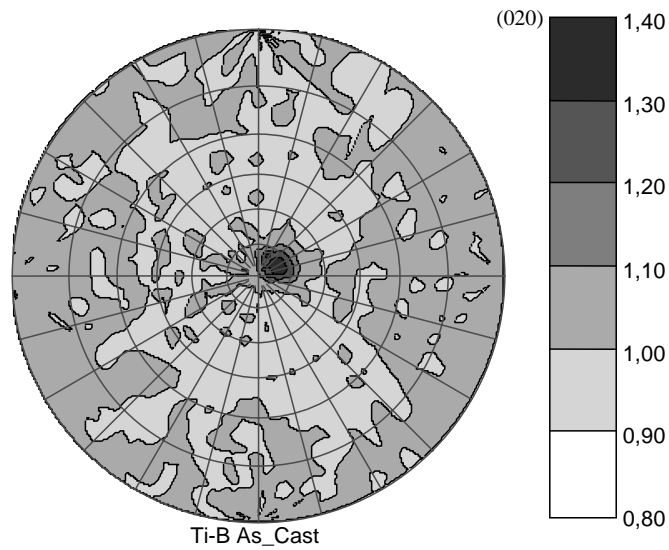
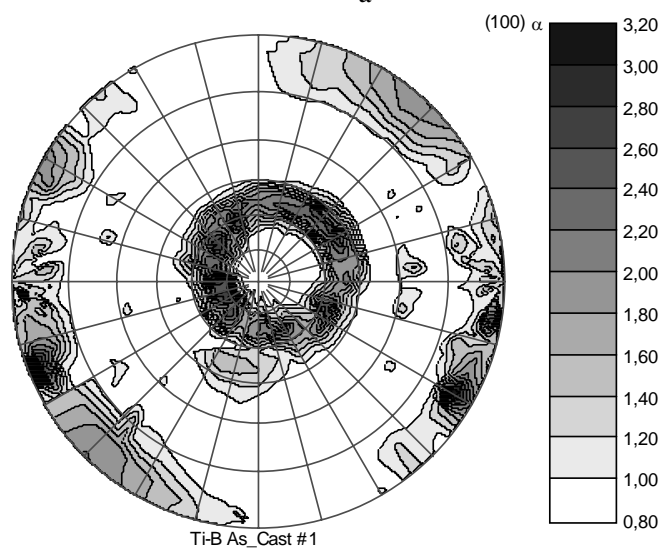

Fig.4. Microstructure of ingots with (a) aligned and (b) random microstructure.



a



b

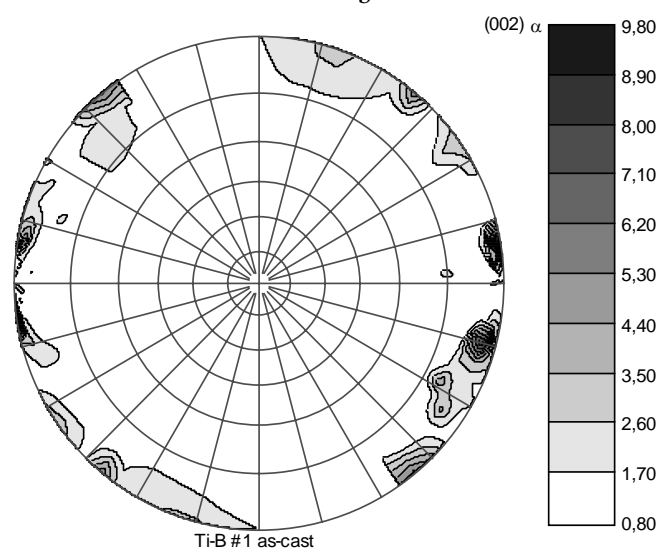

c

Fig. 5. Pole figures: (a) (020) TiB, (b) (100) alpha and (c) (002) alpha in aligned eutectic.

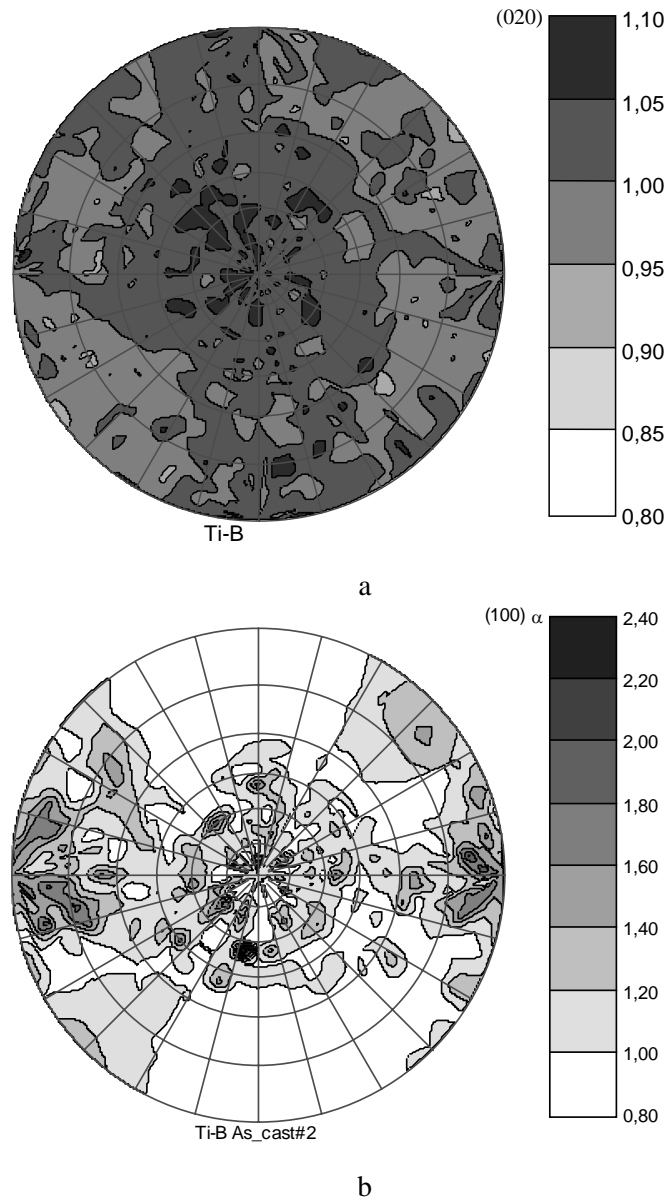

Fig. 6. Pole figures: (a) (020) TiB and (b) (100) alpha in random eutectic.

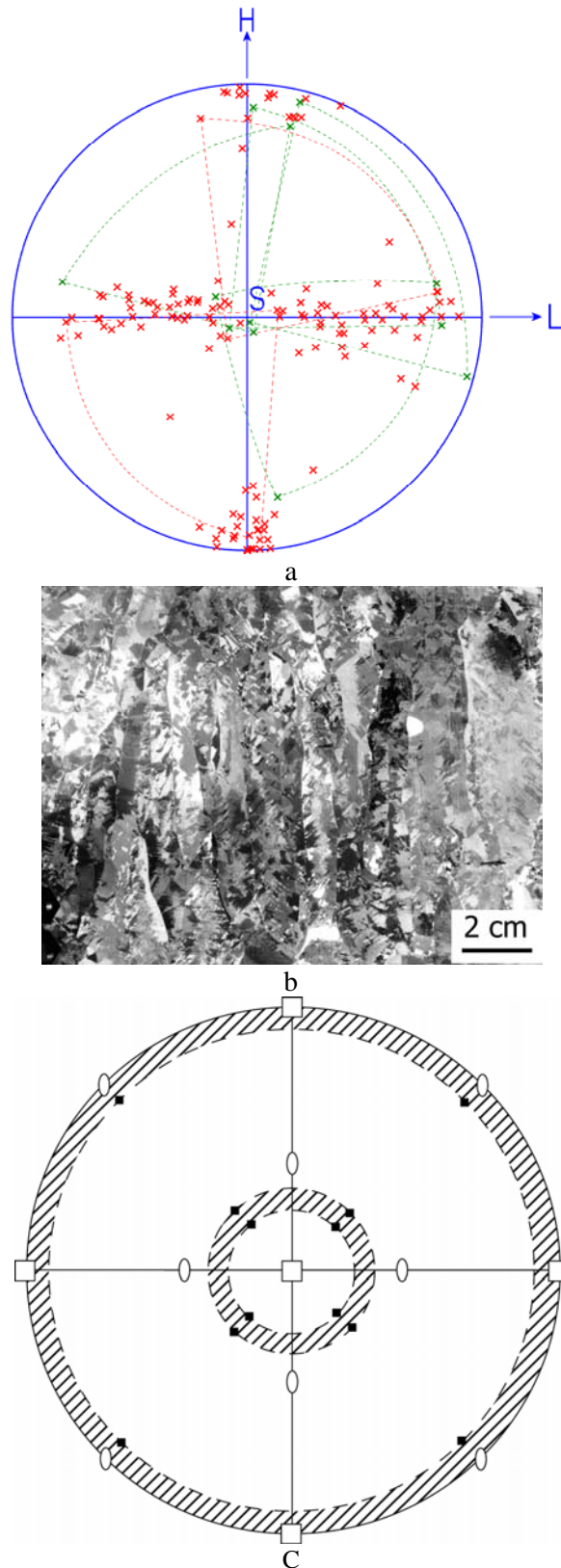

Fig. 7. (a) Stereographic projection of the  $\{200\}$  beta-grain orientation distribution in the central region of ingot with (b) columnar macrostructure [1], (c) -  $(100)\alpha$  theoretical pole figure derived from (a);  $\diamond$ ,  $\square$  – poles of  $\{011\}$  and  $\{100\}$  respectively of initial  $\beta$ -phase single crystal.  $\blacksquare$  – theoretical poles of  $(100)$ ,  $(010)$  and  $(110)$   $\alpha$ -phase for 4 variants of Burgers OR.

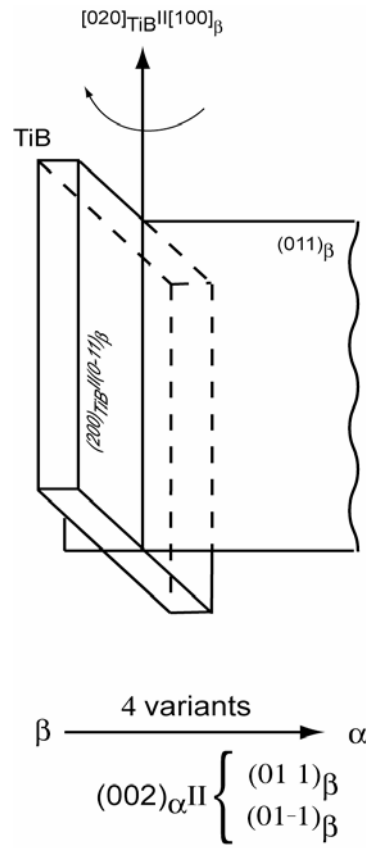

Fig. 8 Crystallography of eutectic couple TiB – beta Ti.

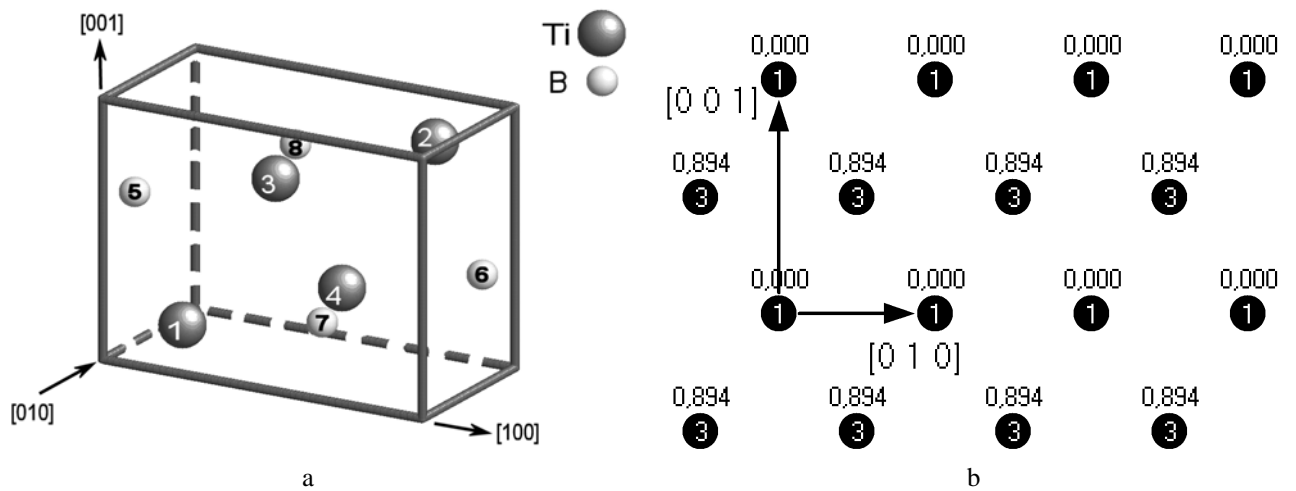

Fig. 9. (a) general view of orthorhombic TiB lattice (B27) and (b) projection of Ti atoms on (200) plane of TiB lattice [2].

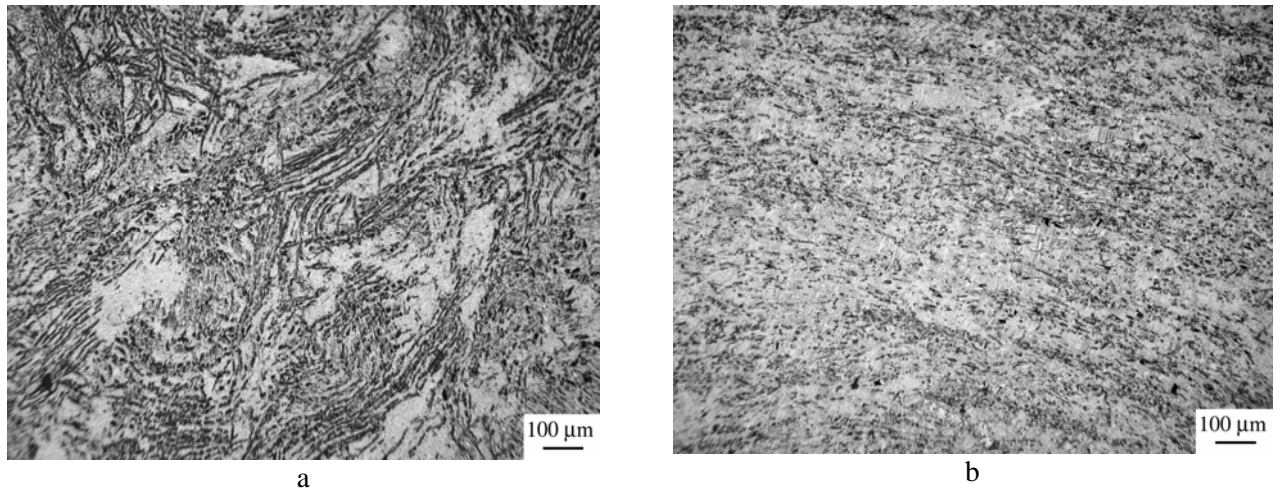

Fig. 10. Microstructure of degenerated eutectic in Ti64-1.55B alloy after (a) 3D forging and (b) subsequent rolling.

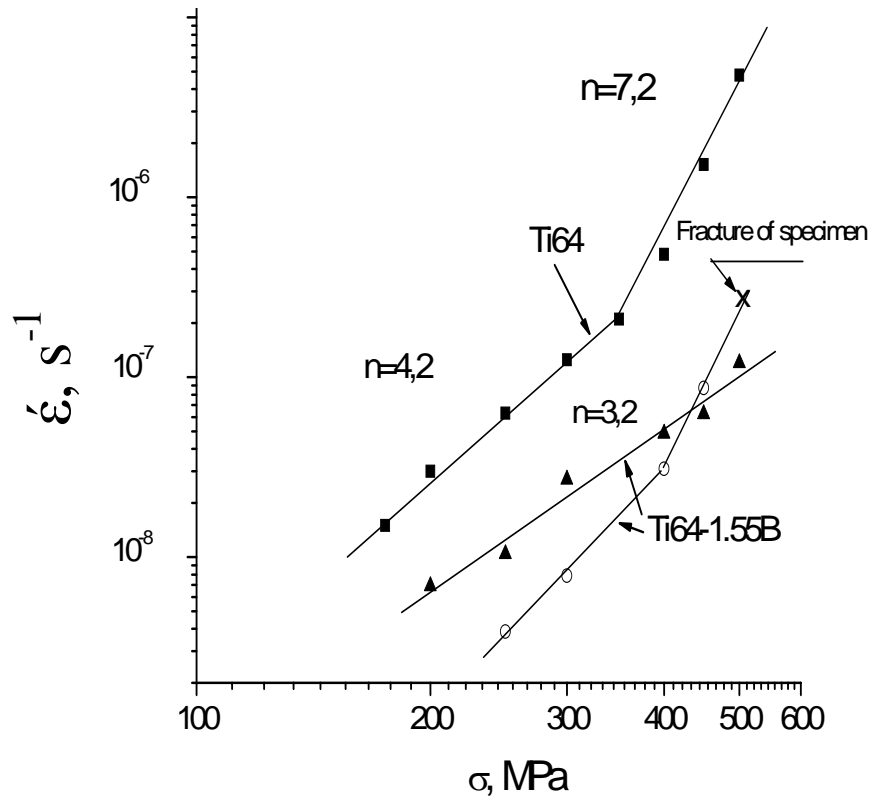

Fig. 11. 500°C creep of (■) conventional Ti64, (▲) as-cast Ti64-1.55B and (○) forged Ti64-1.55B alloys.

*References:*

- [1]. O.M. Ivasishin, V.N. Zamkov, P.E. Markovsky, et al., Characterization of Electron-Beam Melted Ti-6Al-4V Alloy in Cast and Thermomechanically-Processed Conditions, Proceedings of 10<sup>th</sup> World Conference on Titanium 'Ti-2003', 13-18 July 2003, Hamburg, Germany, WILEY-VCH, 2004, V.2, pp. 1259-1266.
- [2]. B.F. Decker and J.S. Kasper, The crystal structure of TiB, Acta Cryst., (154) #7 pp. 77-80.

**2. Summary of personnel commitments.**

Personnel FWS and NFWS were employed in accordance with Project Agreement with some correction of real working time. Participants were employed in the following activities:

<i>Participants</i>	<i>Activities</i>
Ivasishin	2, 3
Ivanchenko	2, 3
Teliovich	2, 3
Markovsky	2, 3
Garasym	-
Pogrebnyak	2, 3
Savvakin	2, 3
Bondareva	2, 3
Levicka	2, 3
Pischak	3
Molyar	2, 3
Mel'nik	2

**3. Description of business travel.**

There were no business trips funded from P-132 project budget during the 5<sup>th</sup> quarter.

**4. Current status.**

Investigations and organizing works are being performed in accordance with the working schedule.

**5. Information about major equipment and materials acquired, other direct costs, related to the project..**

During reporting quarter the following items were purchased and service were paid in accordance with working plan:

- materials: stationery (\$117.80), cartridges (\$315.73+168.55), cutting tolls (\$146.02), photo-consumables (\$72.80);
- other direct costs: Payment for different services (total - \$249.65).

**6. Delays, proposals.**

No.

**Financial report for quarter 5` (agreed with financial officer) - is added**

*Project Manager*

*O.M.Ivasishin*

*Data: July 15, 2005*

**“Ti-based metal matrix composites reinforced with TiB particles”**

Project manager: Prof. O.M.Ivasishin

Tel: (044) 424-22-10, Fax (044)424-33-74, E-mail [ivas@imp.kiev.ua](mailto:ivas@imp.kiev.ua)

Kurdyumov Institute for Metal Physics NASU, Kyiv,

Project duration: 01 February 2004 – 31 March 2006

Financing countries: USA, EOARD

Reporting period: 01.07.2005-30.09.2005

Date of report presentation: 22.10.2005

Project code according to the Science and Technology Area: Primary: 3, 5; Secondary: 11, 13

Content of report of project executing in Quarter 06

1. Short summary of progress	Q06PAGE 1
2. Summary of personnel commitments	Q06PAGE 10
3. Description of business travel	Q06PAGE 11
4. Current status	Q06PAGE 11
5. Overcome problems	Q06PAGE 11
6. Delays and proposals	Q06PAGE 11
Financial report for 06quarter (agreed with financial officer) – attached	ActP132-06s

### 1. Short summary of progress in Quarter 06

During the 6<sup>th</sup> quarter, activities #2 and #3 were being performed.

*Activity number and title*      **2. Producing of experimental ingot for subsequent thermomechanical processing and mechanical testing with arc- induction melting approach.**

*Works performing during the stage*      Taking into account results presented in previous Q05 Progress Report two ingots Ø70mm of Ti64-1.55B alloy with aligned macro and microstructure were melted employing identical melting regimes:  $W_1$  (arc) = 8 kW;  $W_2$  (inductor) = 45 kW. Ingot #1 was cut to characterize the microstructure and texture; ingot #2, which was assumed to have identical macro- and microstructure with the ingot #1, was thermomechanically processed (see activity 3).

It was found that main part of the ingot #1 had generally aligned along ingot axis microstructure shown in Fig 1, although some deviation from alignment was quite evident. The upper part of ingot, which solidified with the arc switched off had an equiaxed macrostructure with a random aligned boride distribution. The availability of two types of macro/microstructure in one ingot gave us the possibility to prepare the green part for thermomechanical processing in such a way that both types were in one piece of processed material and thus were processed identically.

Fig. 2 represents X-Ray diffraction patterns obtained from two sides 1 and 2 of specimen cut from aligned microstructure, which confirm that all phases available ( $\alpha$ ,  $\beta$  and TiB) are textured (intensities of diffraction lines were different when taken from sides #1 and #2). More detailed description of the texture will include a direct high-temperature X-ray measurement of  $\beta$ -phase orientation, which is currently in progress. Tensile tests of this aligned as-cast condition gave following results: YS= 1020 MPa, UTS= 1020 MPa, El.= 0.19%, RA= 1%. It can be assumed that

unacceptably low ductility was due to presence in microstructure of large TiB particles, which sometimes can be unfavorably oriented to the loading direction.

*Activity number and title* 3 .Determination of the thermomechanical processing and heat treatment conditions required to control and produce desired microstructure. Studying of the influence of different regimes of hot deformation and heat treatment on final microstructure and mechanical properties of Ti64B eutectic alloys.

*Works performing during the stage* 1) Mechanical properties of Ti64-1.55B thermomechanically processed (3D-forging+rolling) from random as-cast Ø70 mm ingot microstructure were determined (Table 1, pp. 1-3). 3D forging and, especially, subsequent rolling caused in an improvement of both strength and ductility (compare pp. 1, 2 and 3) due to refinement and alignment of boride particles. Final  $\beta$ -STA treatment resulted in an essential increase of strength keeping rather reasonable ductility (p. 4). This exceptionally high for Ti-6-4 type material properties was due to the possibility to solute treat the material in single phase beta field without a beta-grain growth eliminated by TiB particles. The high strength comes from a full transformation of equilibrium  $\alpha$ + $\beta$  microstructure into aged martensite microstructure in which martensite crystals are very fine, as compared to conventional  $\beta$ -STA of Ti-6-4. Additional strengthening results from aligned borides as well.

Table 1  
Mechanical Properties of Ti64-1.55B (Ø 70 mm ingot)

##	Treatment	Properties			
		YS, MPa	UTS, MPa	El, %	RA, %
1	As-cast	fracture below YS			
2	3D-Forged	1065	1128	2.75	8.5
3	3D-Forged + Rolled	1170	1230	6.0	20.7
4	3D-Forged + Rolled + beta-STA	1380	1495	4.65	14.7

Microstructural study of tensile tested specimens showed that there were no cracks on matrix/borides interfaces or across borides in unstrained zone (Fig. 3a) while such cracks appeared upon straining and finally caused in material failure (Fig. 3b). Especially pronounced was this effect in  $\beta$ -STA condition (Fig. 3c) when stresses in matrix were much higher.

2) Microstructure evolution upon “1D” thermomechanical processing at temperatures of two-phase  $\alpha$ + $\beta$  field only was studied using the green part with both aligned and random microstructures (Fig. 4). Two features of such processing should be stressed: a) material was not at all treated in beta-phase field; b) directionality of loading was such that it should favour the flow of material in the direction of alignment of borides. Forging was done in such way that decreases in thickness of green part from 34 to 18 mm compensated by its elongation rather than by widening. Rolling was done from 18x18 mm square to Ø 14 mm round cross-section.

Microstructures after forging of aligned portion are shown in Figs. 5 and 6. In the most deformed part of forging TiB particles became essentially crushed and aligned in the direction of metal flow, which coincided with direction of starting orientation of borides (Fig. 5). However, in other locations where strain was lower or direction of metal flow was less oriented refinement and alignment of was not so pronounced (Fig. 6).

As expected, microstructure of initial random aligned microstructure after forging was very nonuniform. Although in some locations one could observe quite regular aligned microstructure (Fig. 7a, b) (one can assume that in these locations initial orientation of borides was close to direction of plastic flow), most material exhibited morphological nonuniformity as to size and orientation of borides (Fig. 7c-f) with some of them remaining on the very first stages of crashing.

Being subjected to subsequent “1D” rolling material showed different processability depending on initial alignment, much better in case of initial aligned microstructure. Rolling added to linearity of borides (Fig. 8) although sometimes one can see borides oriented in orthogonal direction even after rolling (Fig. 8d).

Poor deformability of initial random microstructure could be explained by a relatively low temperature at which limited rotation of borides led to a higher possibility for cracking in unfavorably oriented long borides. On the other hand,  $\alpha+\beta$  processing favored formation of fine equiaxed structure of matrix (Fig. 8e).

Mechanical testing of thermomechanically processed materials are in progress.

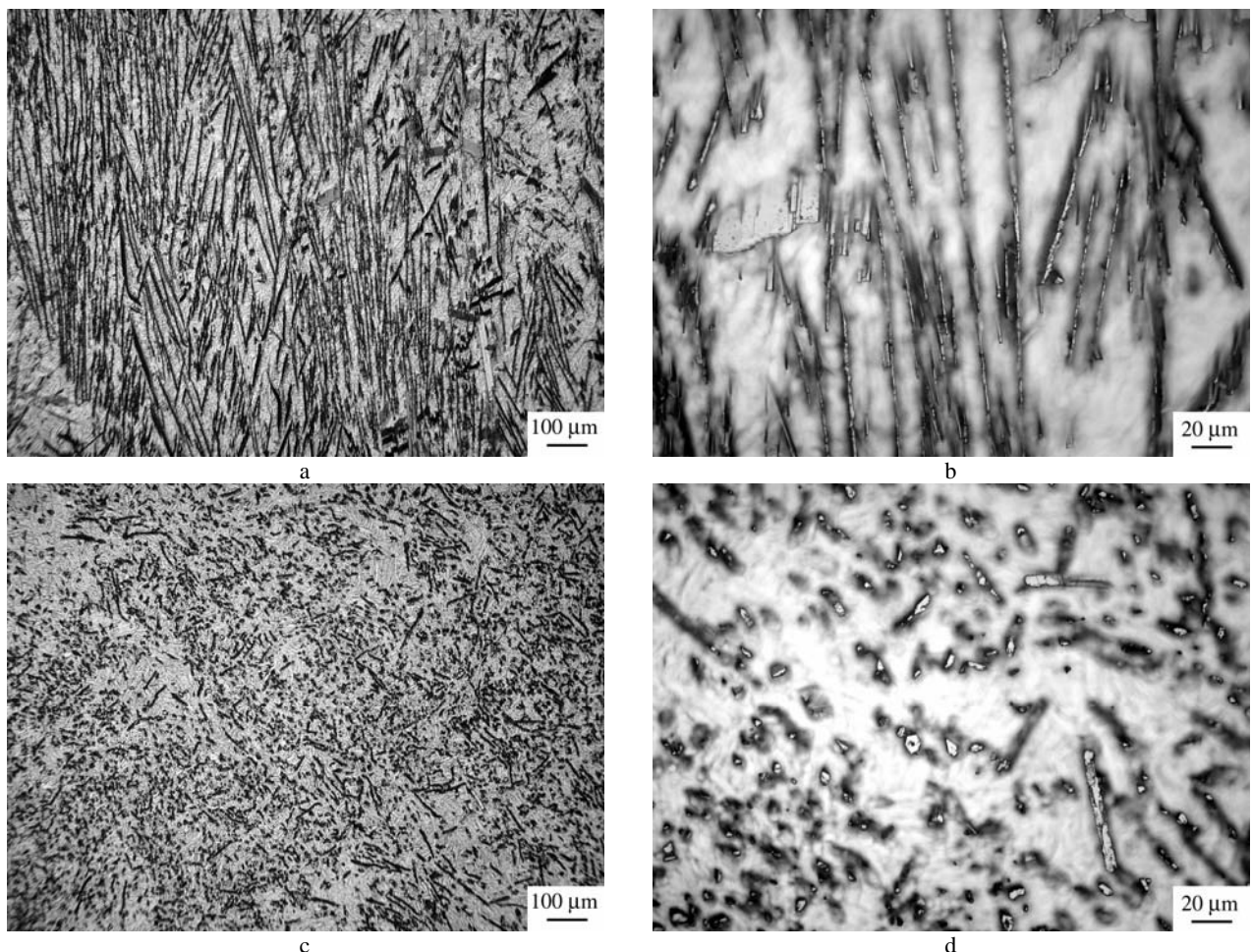

Fig.1 Microstructure of as-cast Ti64-1.55B material with aligned microstructure in: (a, b) longitudinal and (c, d) transverse sections.

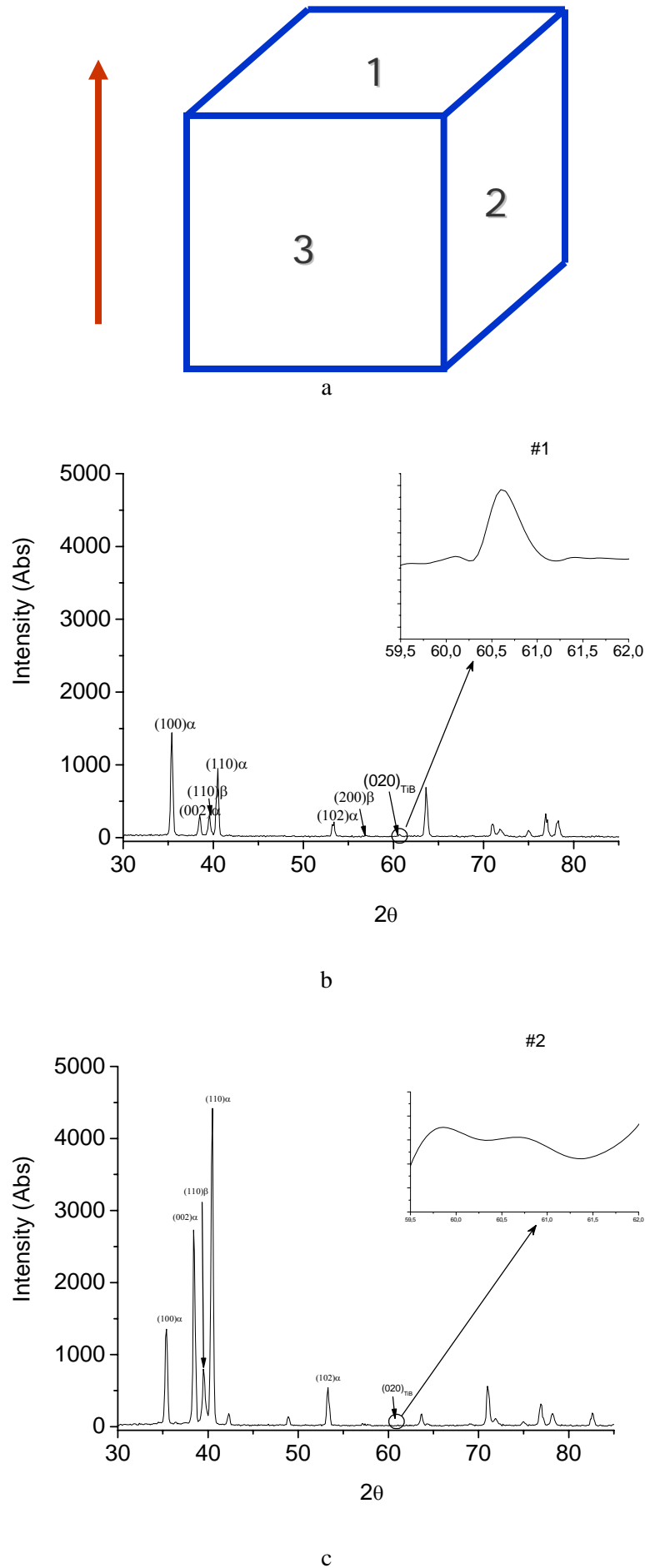

Fig.2. (a) Spatial orientation of studied specimen of as-cast aligned condition and (b-d) X-ray diffraction patterns obtained for relevant (shown on Fig.2a) sides.

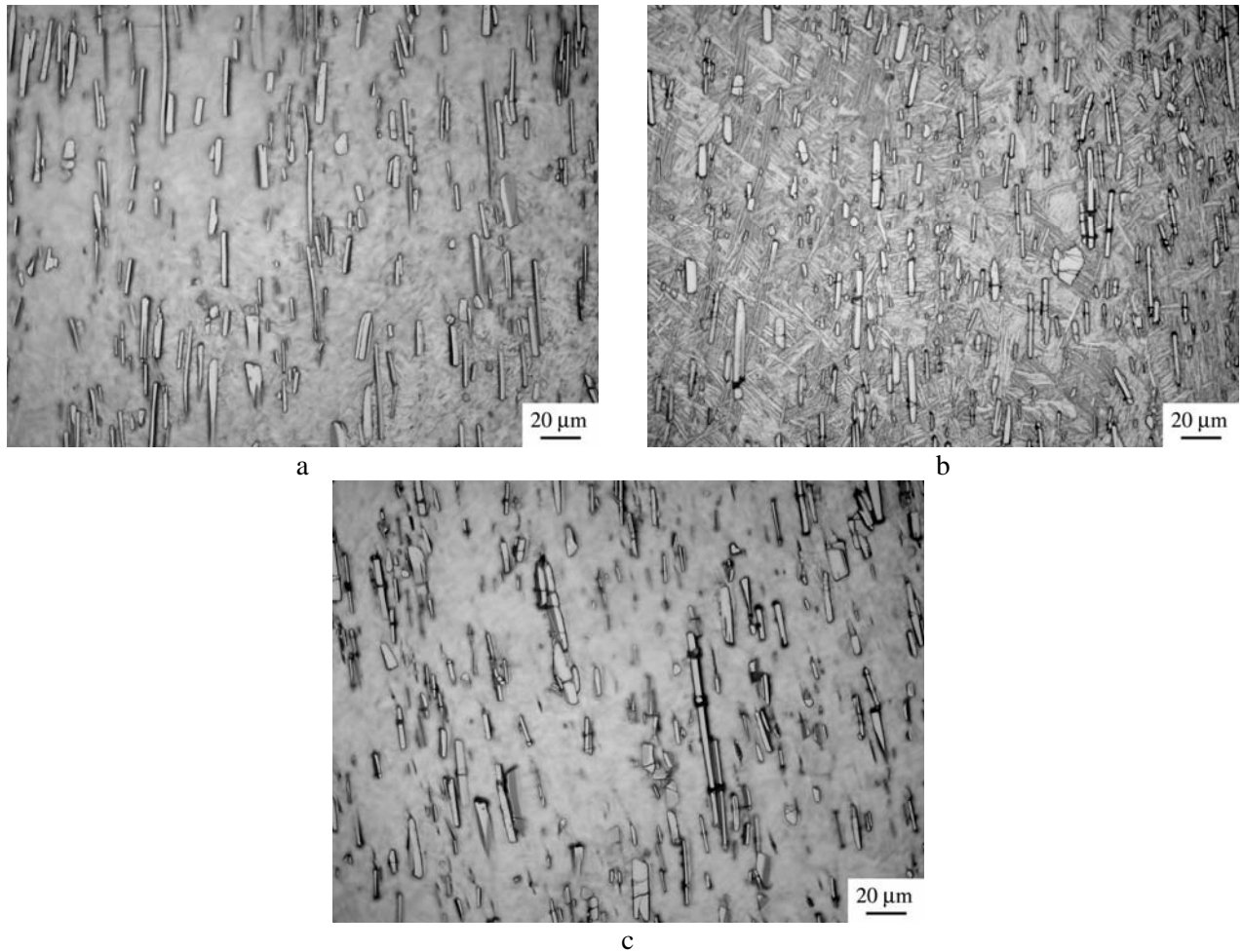

Fig. 5. Longitudinal section of tensile tested specimens: (a, b) 3D-forged and (c)  $\beta$ -STA. (a) – microstructure in initial condition (specimen head) and (b, c) near fracture zone.

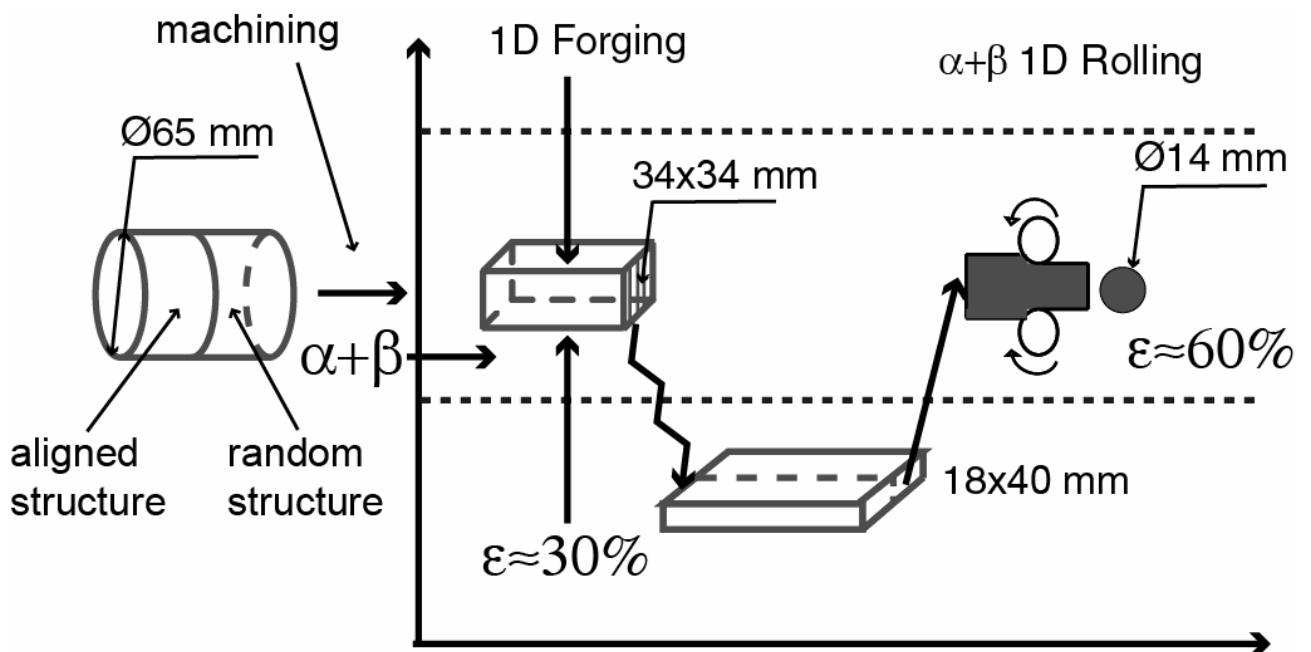

Fig. 4. Scheme of specimen cutting and subsequent thermomechanical processing.

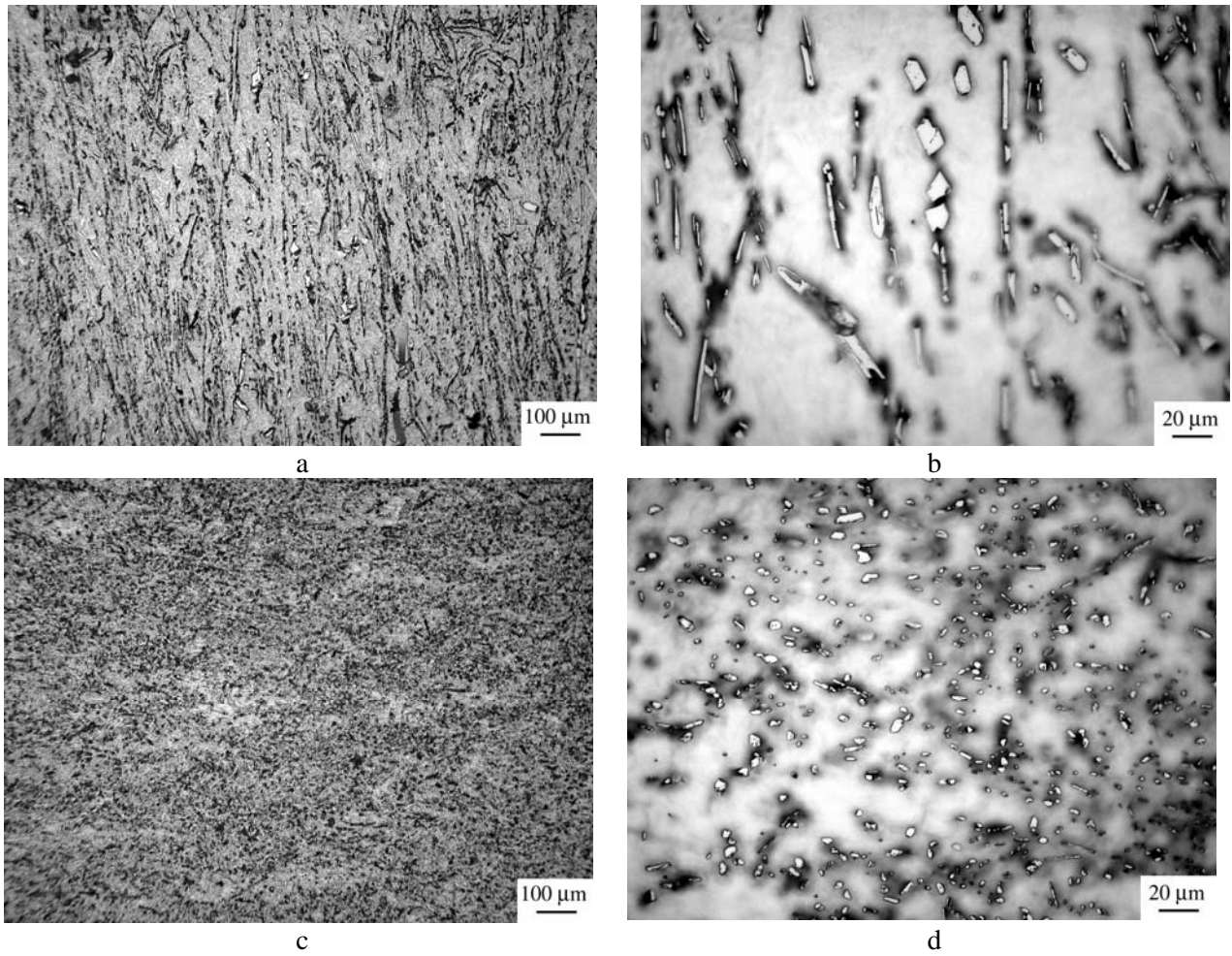

Fig. 5. Microstructure of 1D-forged initially aligned material in the **central (most deformed) part** of forging: (a, b) longitudinal section and (c, d) transverse section.

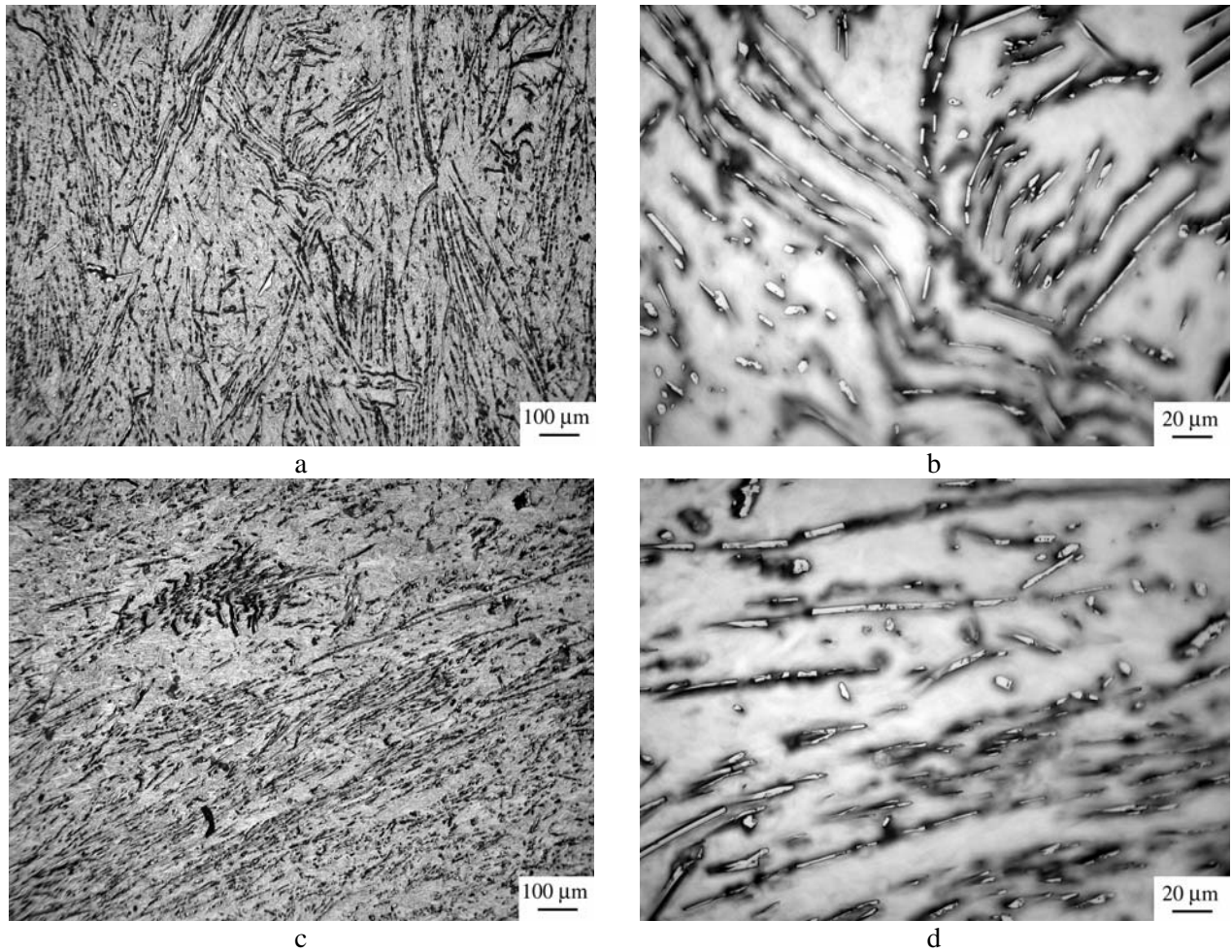

Fig. 6. Microstructure of 1D-forged, initially aligned material in **peripheral locations**: (a, b) longitudinal section and (c, d) transverse section.

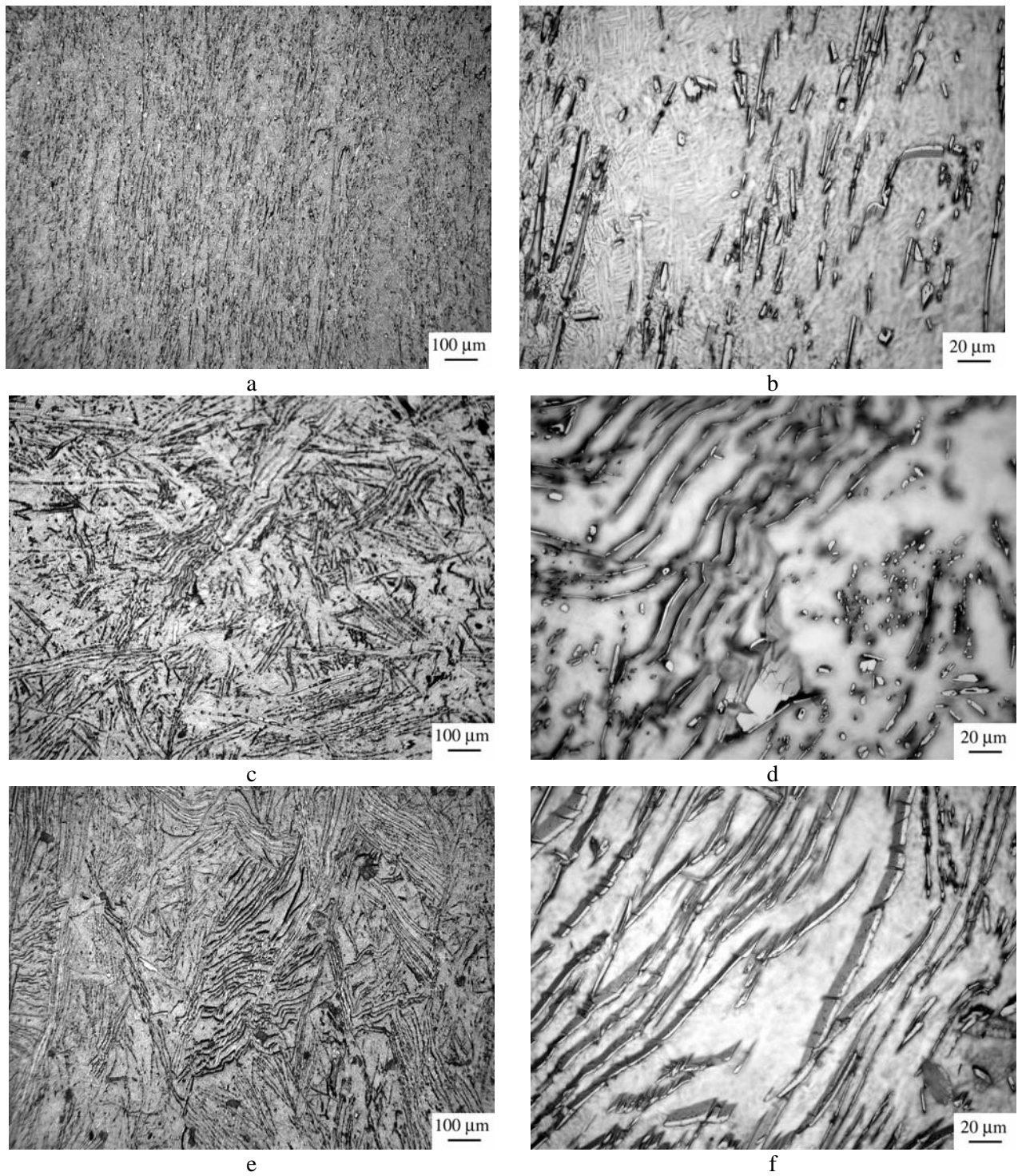

Fig. 7. Typical microstructures of 1D-forged, initially random aligned material.

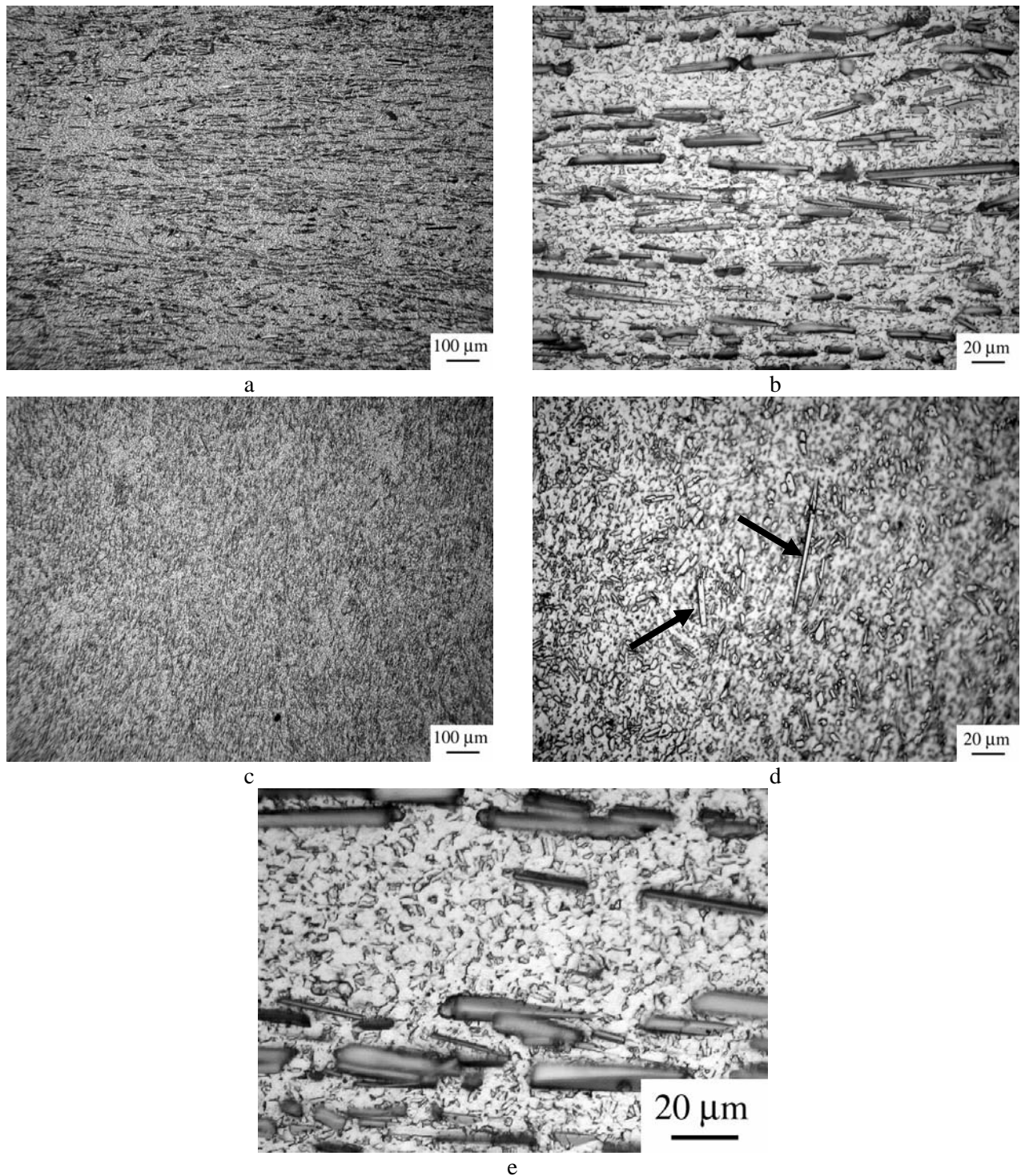

Fig. 8 Final microstructure of the material with initially aligned structure. (a, b, e) – longitudinal section and (c, d) transverse section.

## 2. Summary of personnel commitments.

Personnel FWS and NFWS were employed in accordance with Project Agreement with some correction of real working time. Participants were employed in the following activities:

<i>Participants</i>	<i>Activities</i>
Ivasishin	2, 3
Ivanchenko	2, 3

Teliovich	2, 3
Markovsky	2, 3
Garasym	2, 3
Pogrebnyak	2, 3
Savvakin	2, 3
Bondareva	2, 3
Levicka	2
Pischak	3
Molyar	2, 3
Mel'nik	2

### 3. Description of business travel.

There were no business trips funded from P-132 project budget during the 6<sup>th</sup> quarter.

### 4. Current status.

Investigations and organizing works are being performed in accordance with the working schedule.

### 5. Information about major equipment and materials acquired, other direct costs, related to the project..

During reporting quarter the following items were purchased and service were paid in accordance with working plan:

- materials: stationery (\$136.74), cutting tools (\$302.02), small consumables (\$68.24);
- other direct costs: Payment for different services (\$399.76 + \$230.33).

### 6. Delays, proposals.

No.

**Financial report for quarter 6 (agreed with financial officer) - is added**

*Project Manager*

*O.M.Ivasishin*

*Data: October 25, 2005*

**“Ti-based metal matrix composites reinforced with TiB particles”**

Project manager: Prof. O.M.Ivasishin

Tel: (044) 424-22-10, Fax (044)424-33-74, E-mail [ivas@imp.kiev.ua](mailto:ivas@imp.kiev.ua)

Kurdyumov Institute for Metal Physics NASU, Kyiv,

Project duration: 01 February 2004 – 31 March 2006

Financing countries: USA, EOARD

Reporting period: 01.10.2005-31.12.2005

Date of report presentation: 14.01.2006

Project code according to the Science and Technology Area: Primary: 3, 5; Secondary: 11, 13

Content of report of project executing in Quarter 07

1. Short summary of progress	Q07PAGE 1
2. Summary of personnel commitments	Q07PAGE 7
3. Description of business travel	Q07PAGE 7
4. Current status	Q07PAGE 7
5. Overcome problems	Q07PAGE 7
6. Delays and proposals	Q07PAGE 7
Financial report for 07quarter (agreed with financial officer) – attached	ActP132-07s

### 1. Short summary of progress in Quarter 07

During the 6<sup>th</sup> quarter, activities #2 and #3 were being performed.

*Activity number and title*      *2. Producing of experimental ingot for subsequent thermomechanical processing and mechanical testing with arc- induction melting approach.*

*Works performing during the stage*      In the reported quarter two Scale 3 (Ø70mm) ingots of Ti64-1.55B alloy with aligned macro and microstructure were melted employing earlier specified melting regime:  $W_1$  (arc) = 8 kW;  $W_2$  (inductor) = 45 kW. Ingot #1 was sent to AFRL (Dan Miracle) for subsequent extrusion. Unfortunately, FedEx lost the shipment. Second ingot was subjected to thermomechanical processing: 1D  $\beta$ -forging followed by 1D  $\alpha+\beta$  –rolling. Microstructure characterization and mechanical testing of processed material was done under Activity 3.

Study of solidification texture of aligned as-cast structure was completed, using high-temperature X-ray diffraction and orientation X-ray technique [1]. Typical examples of orientation of beta-phase are presented in Fig.1a, b, d. The results allows to conclude that in aligned structure the beta-phase is oriented by its  $\langle 111 \rangle$  direction along the ingot axis, i.e. of two possible orientation relationships (OR) between titanium beta-matrix and TiB (see Q5 Progress Report)  $(011)\beta \parallel (002) \text{TiB}$ ;  $[020]\beta \parallel \langle 111 \rangle \text{TiB}$  OR is active. Both techniques showed that beta phase texture is not sharp, rather degraded, what is due to a wide spectrum of orientations within an analyzed area, in which it is even difficult to distinguish the “grains”. This finding is in line with an observations that boride’s long axis are not all oriented strictly along the ingot but form rather bundle of borides in which deviation from the main direction can be significant. The orientation of beta phase in crystallographically bounded eutectic should follow those of borides. It should be mentioned that spatial “smearance” of X-ray reflections, both  $\beta$  phase and TiB could be considered as a result of high internal

stresses, but our estimation showed that the stresses were too low to explain the effects observed.

A paper summarizing obtained data is under preparation now.

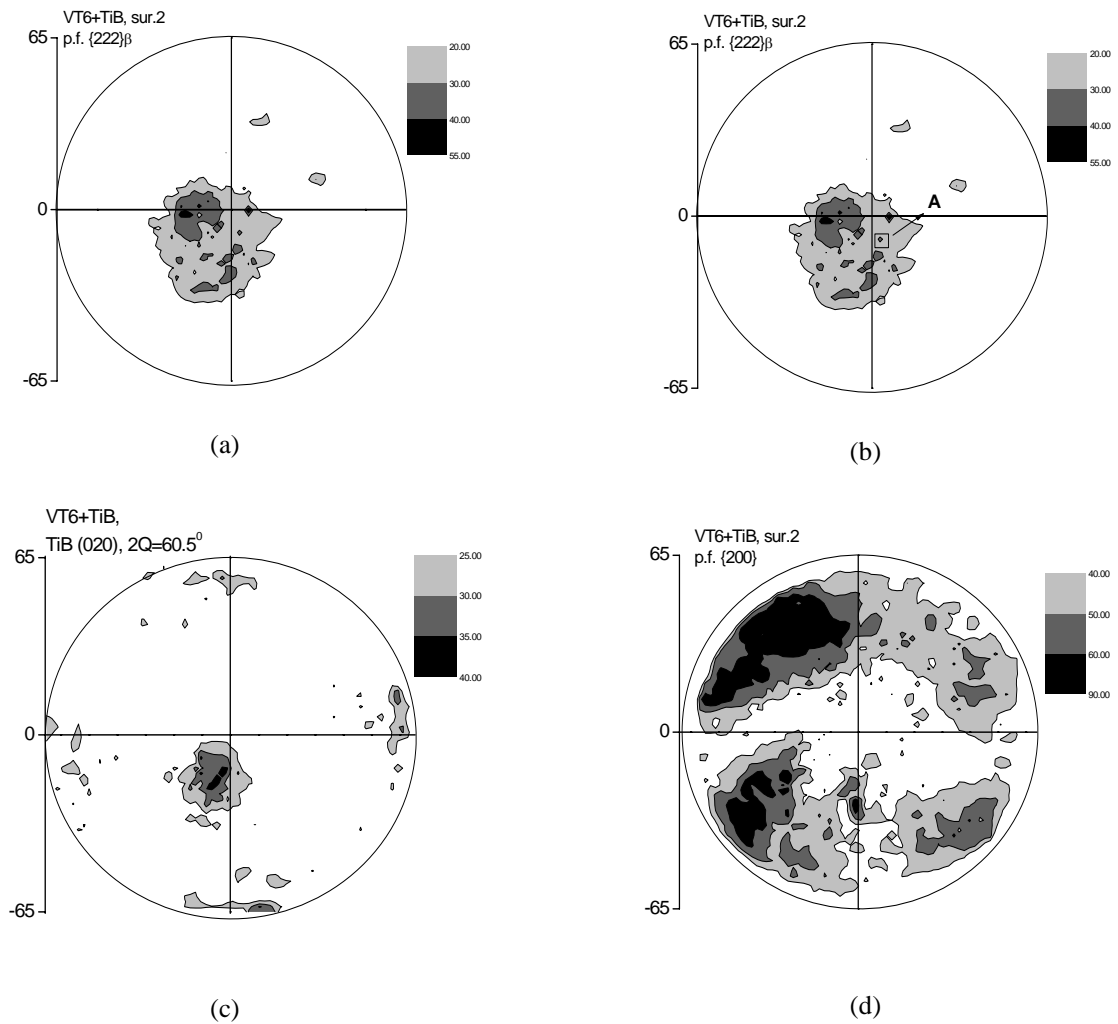

Fig.1. (a, b) Central part of  $\{222\}\beta$  pole figures taken from two neighboring locations on the plane orthogonal to ingot axis;  $\{222\}$  orientations are slightly inclined to the ingot axis. (c, d) – Central part of  $\{020\}$ TiB and  $\{200\}\beta$  pole figures respectively taken from the location (b) in Fig.b; there are no (200) orientation in the center, while distribution of  $\{020\}$  TiB is similar to that of  $\{222\}\beta$ .

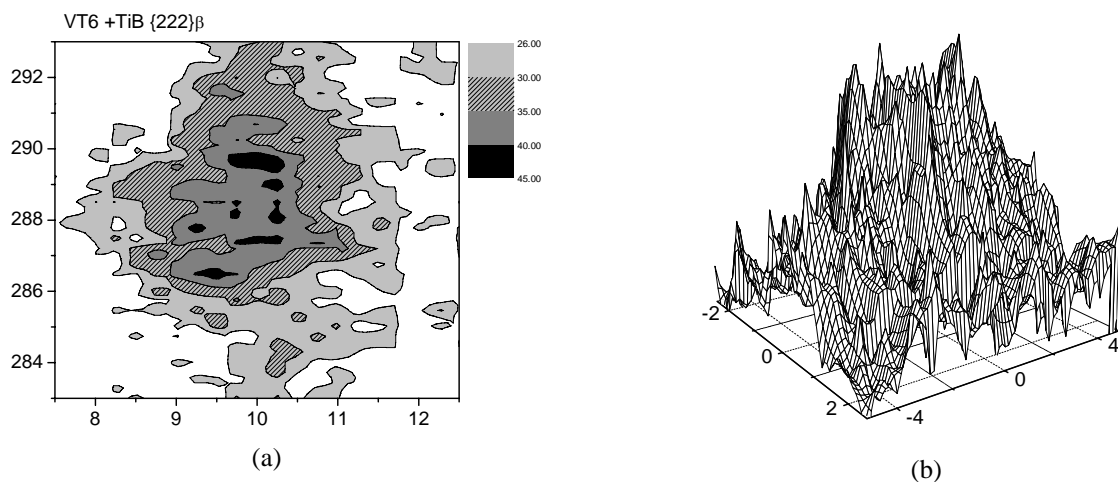

Fig.2. Spatial intensity distribution at specific position of the specimen, shown as A in Fig.1b.

Activity number and title 3. Determination of the thermomechanical processing and heat treatment conditions required to control and produce desired microstructure. Studying of the influence of different regimes of hot deformation and heat treatment on final microstructure and mechanical properties of Ti64B eutectic alloys.

Works performing during the stage During the 7<sup>th</sup> quarter, Scale 3 ingot with aligned structure was thermomechanically processed via the regime that included consecutive “1D”  $\beta$ -forging ( $\text{Ø}65 \text{ mm} \rightarrow 20 \times 20 \text{ mm}$  rod) and 1D  $\alpha+\beta$  rolling ( $20 \times 20 \text{ mm} \rightarrow \text{Ø}14 \text{ mm}$ ). The difference with processing regime used in previous quarter (see Q06 Progress Report) was that forging was performed at temperatures of single-phase beta field. Increased forging temperature ( $1150^\circ\text{C}$ ) was chosen keeping in mind the overall goal to obtain less crashed and thus longer TiB particles as compared to ones obtained after thermomechanical processing completely in two-phase field.

As expected, beta-forging was less critical to fragmentation of borides than  $\alpha+\beta$  forging, leaving some of them quite long, even above  $100\mu\text{m}$  (Fig.3a). However, most of borides were dramatically crashed (Fig.3b). The most unwanted feature of as-forged microstructure was irregular shaped pieces of plate-like borides (Fig.3c) that behaved in unpredictable way in plastic flow sometimes even taking position orthogonal to the long direction (Fig.3d). Moreover, such pieces were well seen after the rolling (Fig.4).

Observation of fracturing of plate-like borides (Fig.5) showed that plates fractured both along and across the plates thus producing a numerous amount of pieces.

More careful examination of material earlier processed from aligned microstructure via  $\alpha+\beta$  forging/  $\alpha+\beta$  rolling revealed similar microstructural feature (e.g. see Fig. 8 in Q6 Progress report), with the only difference that due to lower temperature and, correspondingly, lower possibility for a reorientation in practically flown matrix, the pieces were finer and sometimes could be considered as short fibers.

Matrix microstructure after the rolling was of equiaxed type (Fig.6), as expected after  $\alpha+\beta$  processing. The texture of  $\alpha$ -phase was rather typical for ( $\alpha+\beta$ ) processed Ti-6-4 alloy with clearly resolved two components (Fig.7). Some asymmetry of pole figures originates from forging stage, when there were two orthogonal directions of forging.

After the rolling, part of the material was subjected to additional STA-strengthening heat treatments with solid solutioning at temperatures both above and below beta-transus. Tensile strengths and ductilities of all conditions are listed in Table 1 (average of three tests for each condition). The strength of  $\beta/\alpha+\beta$  processed material has proved to be lower than that of  $\alpha+\beta / \alpha+\beta$  processed one, with an opposite ranking of their ductilities. Ductility for all conditions was less than desirable, assumingly because of specific boride morphology. Such assumption can be confirmed by SEM fracture surface analysis, always showing a presence of flat pieces of borides onto the fracture (Fig. 8). The material became slightly more ductile after annealing ( $800^\circ\text{C}$ , 2h, compare pp.1 and 2). STA-treatment led to some increase in strength, more significant in case of beta-solid solutioning. And again, stronger  $\beta$ -STA condition was disadvantageous in ductility.

Thus, it can be concluded that lower that desired ductility in Ti64-1.55B with aligned microstructure as compared to that of the same material with random structure results from higher fraction of plate-like borides crashed upon thermomechanical processing. Unfortunately, this can not be avoided since to get aligned as-cast microstructure  $W_1$  (arc power) should be kept lower with  $W_2$  (inductor power) being high. Low arc power means low crystallization (cooling) rate (lower supply of the material into the melt pool). In turn, as it was shown earlier, lower cooling rate favors plate-like morphology of borides in eutectic. It can be concluded that for better ductility, random type of as-cast microstructure is preferable. Plate-like morphology is

undesirable because it contributes well to a formation of cracks on matrix/ boride boundaries upon thermomechanical processing and/ or test loading. Just such cracks, as it was earlier shown by Dan Miracle and Sesh Tamirisa [2], are responsible for a low ductility of boron modified titanium alloys.

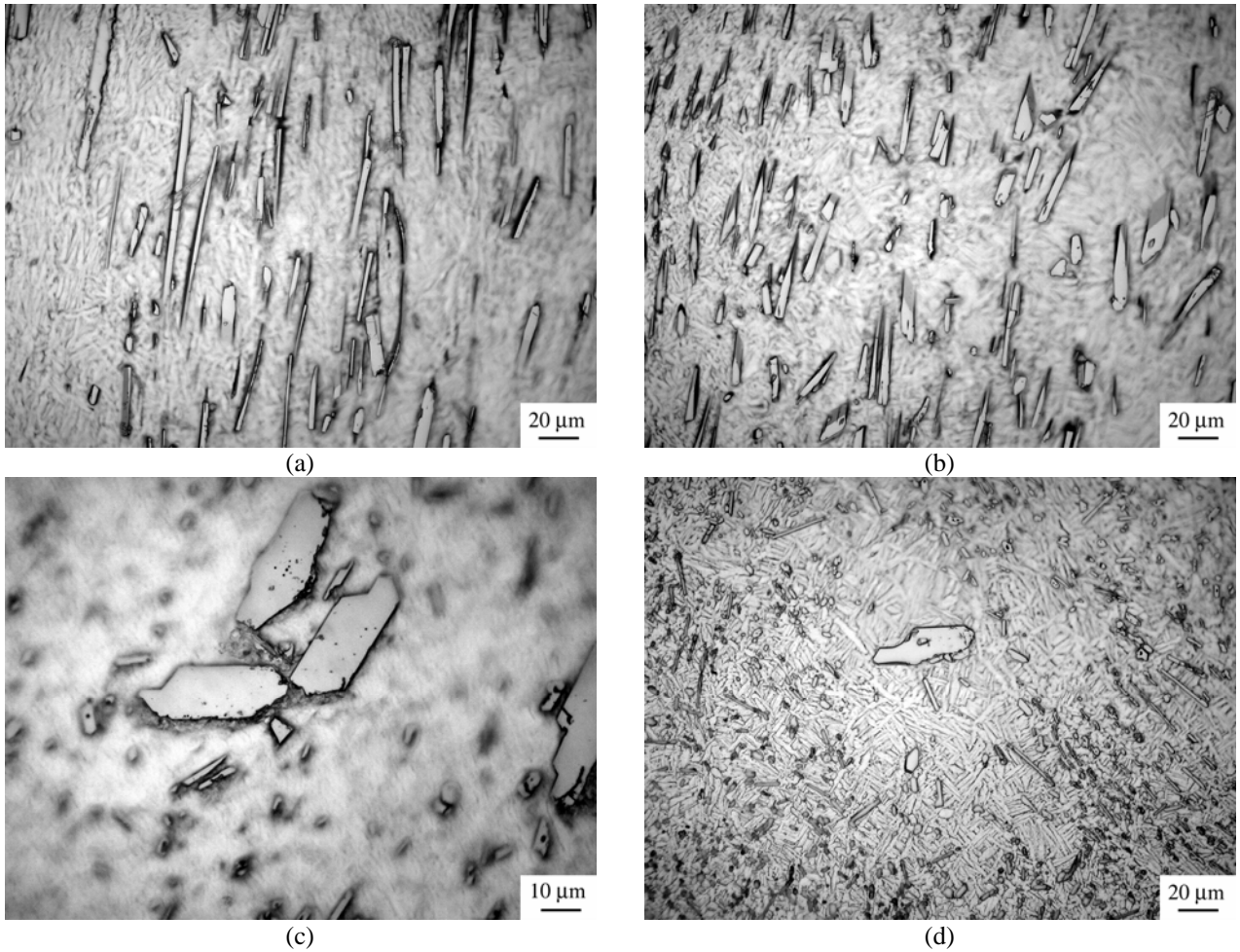

Fig. 3. Microstructure of Ti64-1.55B in “1D” beta-forged condition. (a – c) – longitudinal direction, (d) – transverse direction.



Fig. 4 Microstructure of Ti64-1.55B in “1D” beta-forged /  $\alpha+\beta$  rolled condition.

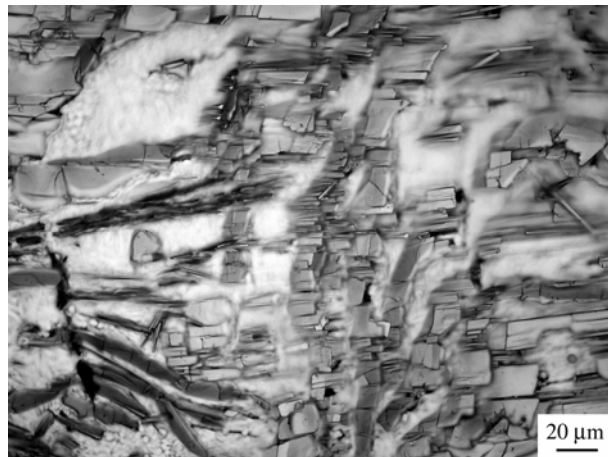
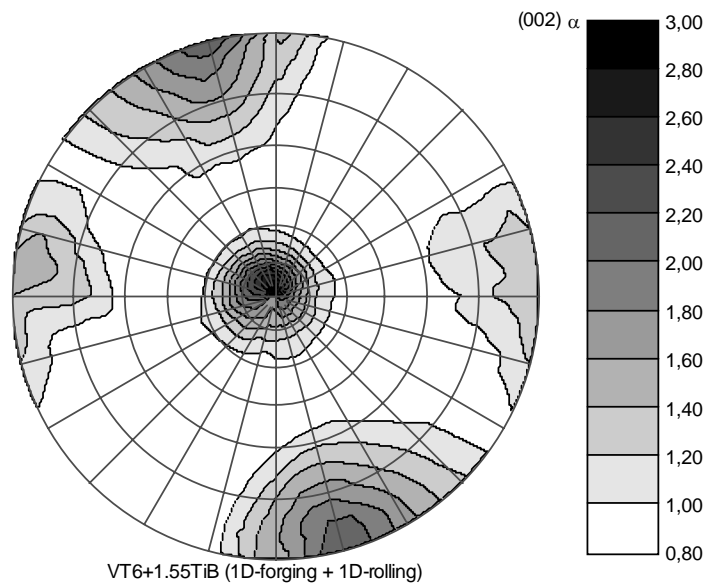

Fig. 5 Severe crashing of TiB plates at forging.



Fig. 6. Globular matrix in "1D" beta-forged /  $\alpha+\beta$  rolled Ti64-1.55B material.



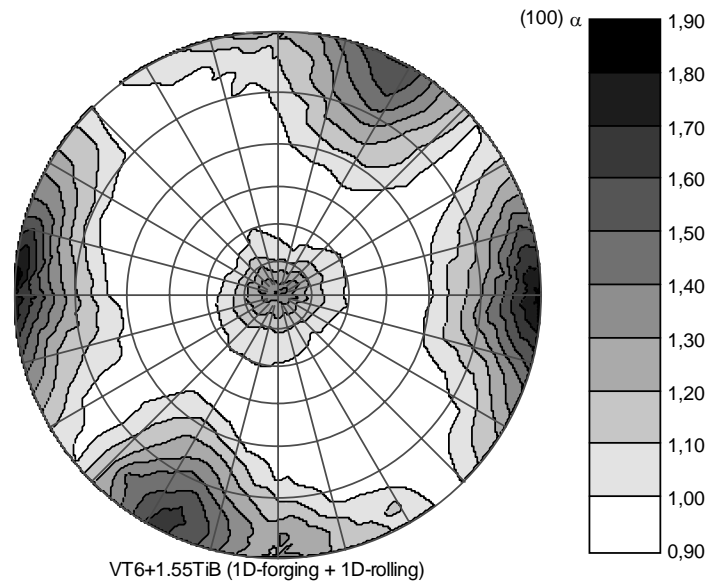

Fig.7. (002) $\alpha$  and (100) $\alpha$  pole figures of  $\beta$  forged /  $\alpha+\beta$  rolled Ti64-1.55B.

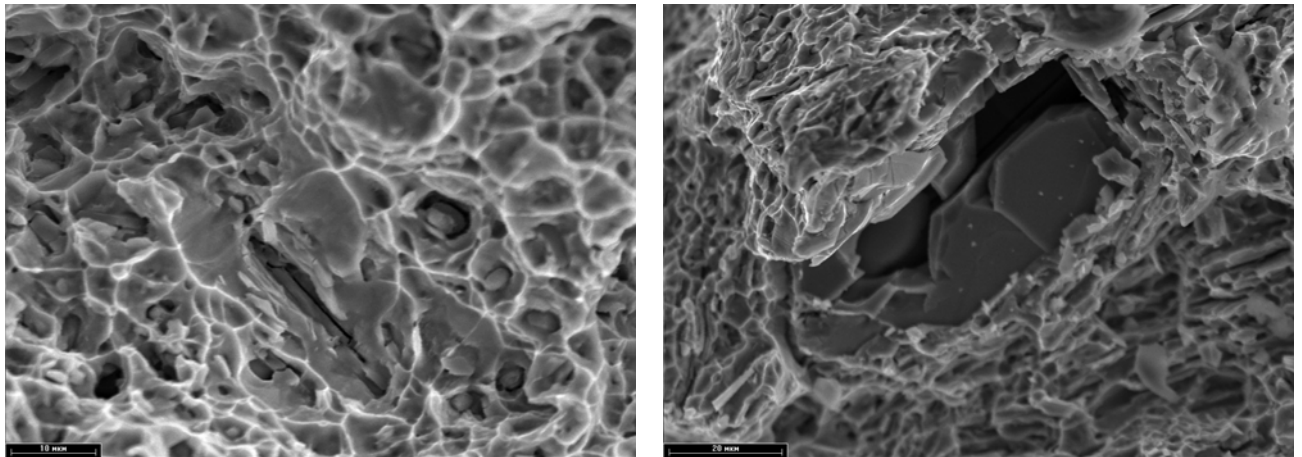

Fig.8 SEM images of fracture surfaces of  $\beta$  forged/  $\alpha+\beta$  rolled Ti64-1.55B.

Table 1  
Mechanical Properties of Ti64-1.55B with initial aligned microstructure

##	Condition	Mechanical Properties			
		YS, MPa	UTS, MPa	El., %	RA, %
1	1D- $\alpha+\beta$ -forged+1D- $\alpha+\beta$ -Rolled	1180	1242	4.1	21.2
2	1D- $\beta$ -forged+1D- $\alpha+\beta$ -Rolled	1210	1350	3.1	14.3
3	As (2) + 800°C, 2 h	1190	1285	4.2	22.5
4	As (2) + 800°C, 2 h + 900°C, 30', WQ + 520°C, 8h	1250	1370	3.7	16.5
5	As (2) + 800°C, 2 h + 1050°C, 30', WQ + 520°C, 8h	1290	1470	2.5	8.7

**References.**

- [1] O.P. Karasevskaya, O.M. Ivasishin, S.L. Semiatin, Yu.V. Matviychuk. Deformation behavior of beta-titanium alloys // Materials Science and Engineering A.- 2003.- Vol. 354.- P.121-132.
- [2] S. Tamirisa, R. Bhat, D.J. McEldowney, J.Tiley, and D. Miracle, Microstructure refinement of titanium alloys via boron addition, Proc. of symposium "Titanium alloys modified with boron", 11-13 October, Dayton, OH.

## 2. Summary of personnel commitments.

Personnel FWS and NFWS were employed in accordance with Project Agreement with some correction of real working time. Participants were employed in the following activities:

<i>Participants</i>	<i>Activities</i>
Ivasishin	2, 3
Ivanchenko	2, 3
Teliovich	2, 3
Markovsky	2, 3
Garasym	2, 3
Pogrebnyak	2, 3
Savvakin	2, 3
Bondareva	2, 3
Levicka	2
Pischak	3
Molyar	2, 3
Mel'nik	2

## 3. Description of business travel.

There were no business trips funded from P-132 project budget during the 7<sup>th</sup> quarter. Using WOS money Prof. Ivasishin took part in symposium "Titanium alloys modified with boron", 11-13 October, Dayton, OH, where he presented paper "Microstructure, texture and mechanical properties of Ti6Al4V-TiB eutectic".

## 4. Current status.

Investigations and organizing works are being performed in accordance with the working schedule.

## 5. Information about major equipment and materials acquired, other direct costs, related to the project..

During reporting quarter the following items were purchased and service were paid in accordance with working plan:

- materials: titanium sponge (\$825.53), small consumables (\$87.85);
- other direct costs: payment for different services (\$851.45, 930.77, 344.55), and for shipment and custom service for ingot delivery to AFRL (\$93.07).

## 6. Delays, proposals.

No.

**Financial report for quarter 7 (agreed with financial officer) - is added**

*Project Manager*

*O.M.Ivasishin*

*Data: January 18, 2006*

**“Ti-based metal matrix composites reinforced with TiB particles”**

Project manager: Prof. O.M.Ivasishin

Tel: (044) 424-22-10, Fax (044)424-33-74, E-mail [ivas@imp.kiev.ua](mailto:ivas@imp.kiev.ua)

Kurdyumov Institute for Metal Physics NASU, Kyiv,

Project duration: 01 February 2004 – 31 March 2006

Financing countries: USA, EOARD

Reporting period: 01.01.2006-31.03.2006

Date of report presentation: 14.04.2006

Project code according to the Science and Technology Area: Primary: 3, 5; Secondary: 11, 13

Content of report of project executing in Quarter 08

1. Short summary of progress	Q08PAGE 1
2. Summary of personnel commitments	Q08PAGE 10
3. Description of business travel	Q08PAGE 11
4. Current status	Q08PAGE 11
5. Overcome problems	Q08PAGE 11
6. Delays and proposals	Q08PAGE 11
Financial report for 08quarter (agreed with financial officer) – attached	ActP132-08s

### 1. Short summary of progress in Quarter 08

During the 8<sup>th</sup> quarter, activities #3 and #4 were being performed.

*Activity number and title*      3. *Determination of the thermomechanical processing and heat treatment conditions required to control and produce desired microstructure. Studying of the influence of different regimes of hot deformation and heat treatment on final microstructure and mechanical properties of Ti64B eutectic alloys.*

*Works performing during the stage*      1) During the reported quarter, an ingot with aligned microstructure was melted and sent to Write-Patterson AFRL, instead of the ingot lost on shipping. This ingot was subjected to extrusion in AFRL and is now under investigation.

One more ingot (with random aligned structure) was melted and thermomechanically processed. Obtained material was used for more detailed study of influence of refined TiB skeleton produced with thermomechanical processing, on microstructure evolution during various post-processing heat treatments. The following heat treatments were studied:

- i) annealing at temperature of  $\alpha+\beta$  field (800°C, 2h) followed by furnace cooling (FC);
- ii) annealing at temperature of single-phase beta field (1050°C, 30') followed by FC;
- iii) STA- treatment, which included beta-solid solutioning (1050°C, 30'), water quenching, and final aging (520°C, 8h).

Thermomechanically processed condition was obtained via the regime that included consecutive “1D”  $\beta$ -forging ( $\varnothing 65$  mm  $\rightarrow$  20x20 mm rod) and 2D  $\alpha+\beta$  rolling (20x20 mm  $\rightarrow$  12x12 mm).

After beta-forging, microstructure showed rather fine and uniformly redistributed

(as compared to as-cast condition) TiB particles, more or less aligned mainly along direction of last stage metal flow (Fig.1a, b). Matrix had beta-transformed lamellae type microstructure. The lamellae were short; their size was limited by distance between neighboring TiB particles. Subsequent  $\alpha+\beta$  rolling caused in further alignment of borides, and their long size additionally decreased. Lamellar matrix transformed into equiaxed one (Fig.2a). It should be underlined that  $\alpha+\beta$  matrix was unusually nonuniform and included two-scale alpha globules.

Annealing of rolled material in  $\alpha+\beta$  field did not lead to significant changes in the material (Fig. 2b).

Annealing in single-phase beta field resulted in unexpected microstructure, which could be defined as coarse equiaxed (Fig. 3), instead of being beta-transformed lamellar  $\alpha+\beta$  microstructure typical for Ti-64 alloy. Especially pronounced “equiaxed” type of microstructure was in transverse sections.

Water quenching after single-phase beta-solid solutioning caused in formation of martensite microstructure (Fig.4). In contrast to conventional Ti64 alloy, in which after such a treatment coarse primary martensite crystals are formed (their length is limited by beta-grain size), the martensite in boron modified alloy was extremely fine indicating on availability of barriers eliminating martensite lath size.

Summarizing above mentioned features of thermomechanically processed and heat treated Ti64-1.55B material it is possible to conclude that presence of TiB particles caused in essentially different, as compared to Ti-64 alloy, behavior on different stages of processing. Most important difference is that fine TiB particles eliminate beta-grains growth in matrix. The beta-grain size, or, respectively, density of grain boundaries is a microstructural feature, which defines, to overwhelming extent, morphology of beta transformation products. In alloys like Ti-64 these boundaries are the only sites for alpha lamellar nucleation at slow cooling, forming colony type microstructure. On the other hand, beta grain boundaries are barriers to growth of alpha crystals of any orientation. Borides is another microstructural feature capable in direct changing of the morphology of beta transformation products (besides of eliminating beta grain growth). There is no doubt that borides will stop growing alpha-crystals. Less convincing looks assumption on possibility of the nucleation of  $\alpha$ -phase on boride surface done by Prof. Fraser and his group while explaining a formation of “equiaxed” alpha in slowly cooled boron modified titanium alloys. In our view, “equiaxed” alpha resulted from fine beta-grain size and slow cooling. Due to the latter, only a few nuclei appear on the beta grain boundaries, which growth towards the grain interiors is limited by grain size. Intermediate cooling rates would result in beta-transformed microstructure having higher aspect ratio due to higher nucleation rate and thus, more numerous alpha crystals. On the fastest cooling (WQ) TiB particles and fine-grained beta structure lead to essential refinement of acicular (martensite) microstructure.

Analysis of tensile test results (Table 1) shows that heat treatments, which include heating above beta-transus, does not cause in detrimental decrease in ductility like that in case of conventional Ti-64. Table 1 combines test results of the last heat described above, numbered 1, and two other heats numbered 2 and 3, with random (see Q06 progress report) and aligned (see Q07 Progress Report) microstructures respectively. Such presentation allows to see general trends in how heat treatments influence the balance of strength and ductility. It can be seen that  $\alpha+\beta$  annealing slightly decreases the strength while improving the ductility. Beta annealing results in the lowest strength; the ductility gain is not pronounced. Beta STA is potential in increasing the strength while ductility level is still quite admissible. As it was stressed in Q07 Progress Report, aligned as-cast microstructure resulted in worse balance of strength and ductility due to a specific morphology of borides at low cooling rate.



(a)



(b)

Fig. 1. Examples of microstructure of 3D-beta-forged Ti-64-1.55B with more or less alignment of borides. Longitudinal section.

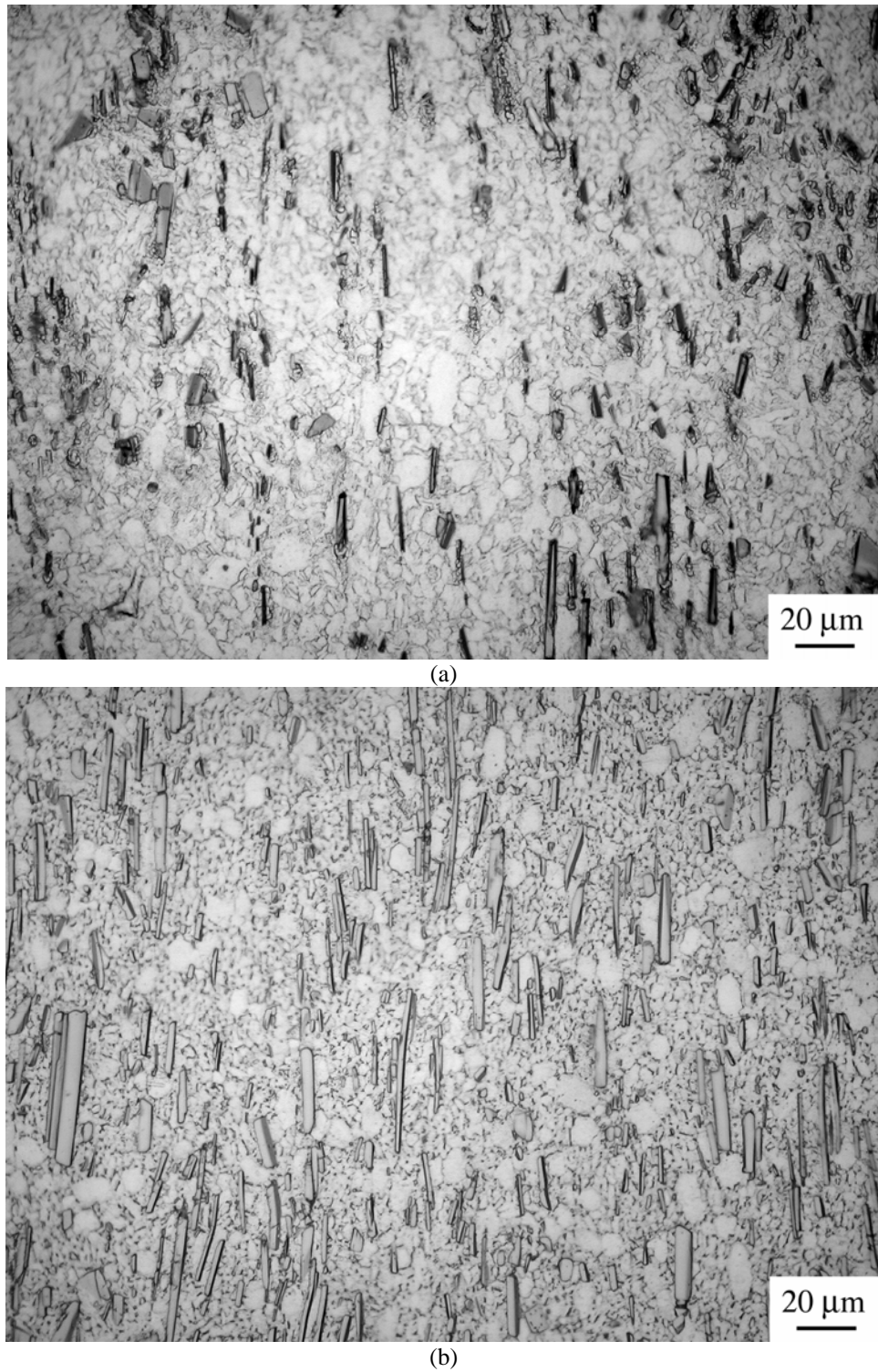
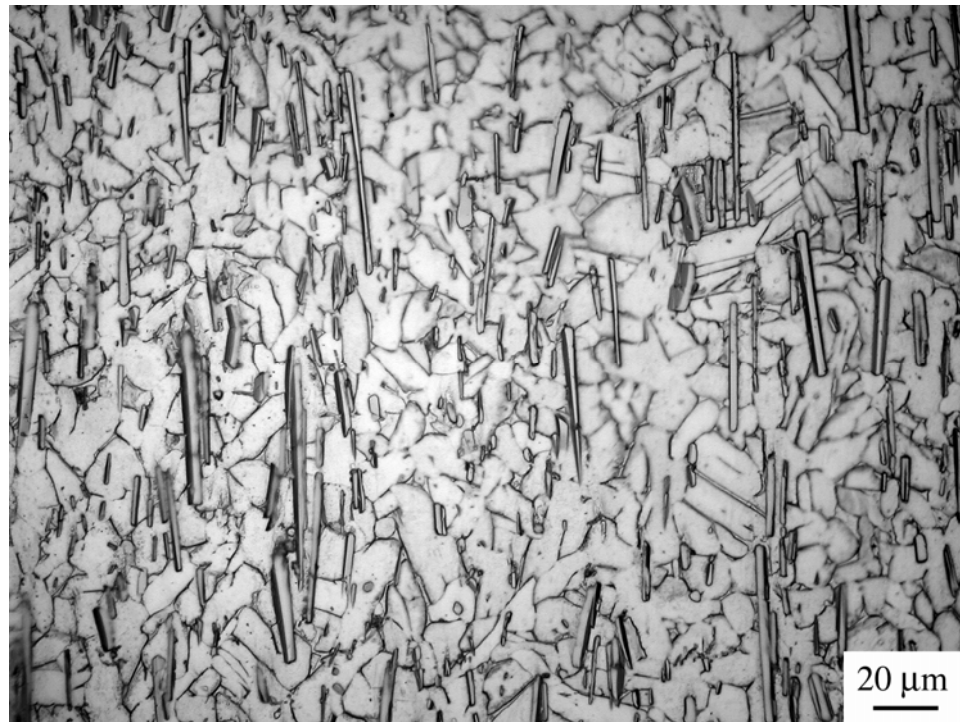
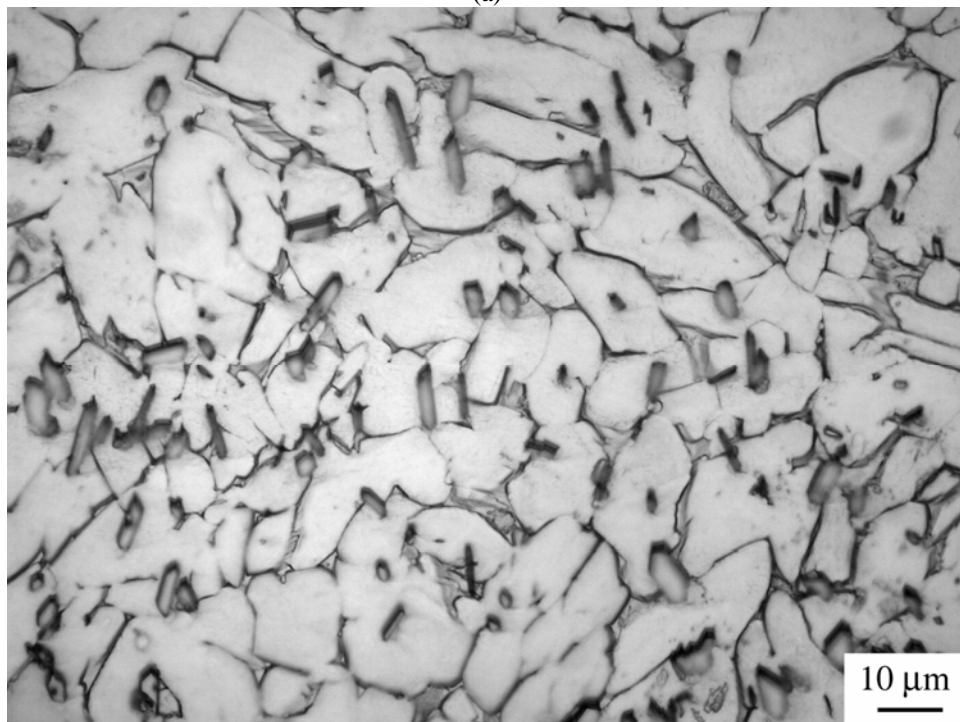

Fig.2. Microstructure of Ti64-1.55B with initial random aligned microstructure in “3D” beta-forged and  $\alpha+\beta$  rolled condition (a), and after additional annealing 800°C, 8h. Longitudinal direction.



(a)



(b)

Fig.3. Microstructure of Ti64-1.55B with initial random aligned microstructure in 3D-beta-forged and  $\alpha+\beta$  rolled condition after annealing 1050°C, 30' and FC. (a) - Longitudinal section, (b) - transverse section.

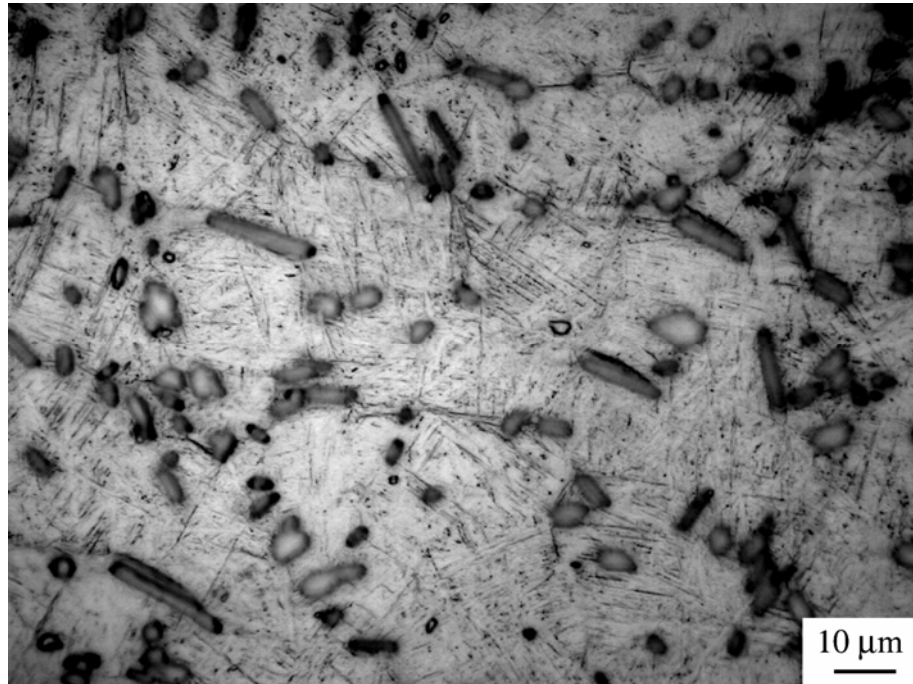

Fig. 4 Microstructure of beta-STA Ti-64-1.55B alloy. Transverse section.

Table 1

Mechanical Properties of Ti64-1.55B

##	Condition	Mechanical Properties			
		YS, MPa	UTS, MPa	El., %	RA, %
$\beta$ -Forged + ( $\alpha$ + $\beta$ )-Rolled					
1	Heat #1	1170	1238	5.1	26
2	Heat #2	1170	1230	6.0	20.7
3	Heat #3	1210	1350	3.1	14.3
$\beta$ -Forged + ( $\alpha$ + $\beta$ )-Rolled + 800°C, 2 h					
4	Heat #1	1120	1209	5.4	19.4
5	Heat #3	1190	1285	4.2	22.5
$\beta$ -Forged + ( $\alpha$ + $\beta$ )-Rolled + 800°C, 2 h + 1050°C, 30', FC					
6	Heat #1	1000	1112	5.2	23.9
$\beta$ -Forged + ( $\alpha$ + $\beta$ )-Rolled + 800°C, 2 h + beta-STA (1050°C, 30', WQ + 520°C, 8h)					
7	Heat #1	1340	1451	4.2	21
8	Heat #2	1380	1495	4.65	14.7
9	Heat #3	1290	1470	2.5	8.7

2) "In situ" high-temperature X-ray study was completed. Main result of these experiments was a confirmation of  $\langle 111 \rangle_{\beta}$  solidification texture assumed from the orientational X-ray analysis (see Q07 Progress report). Experimental stereographic projection built for separate eutectic grain (colony) shown in Fig.5, as well as generalized projections built for several colonies (Fig.6) are well in line with this assumption.

It should be stressed that solidification texture for conventional Ti-64 ingot is of  $\langle 100 \rangle_{\beta}$  axial type [1]; moreover such a texture is rather common for b.c.c. metals. Change of texture type from  $\langle 100 \rangle_{\beta}$  to  $\langle 111 \rangle_{\beta}$  in Ti64-1.55B alloy is obviously due to the influence of TiB phase. OR (010)TiB  $\parallel$   $\langle 100 \rangle_{\beta}$  is certainly defined by mechanism of nucleation and growth of

eutectic pair on solidification, in particular, by crystallographic nature of TiB/beta interface. It may be assumed that formation of two-phase center of eutectic colony occurs via nucleation of the second phase on a surface of the first one. In case of essential difference between two eutectic constituents, like in Ti64-1.55B alloy, TiB will nucleate as a leading phase because of more complicated crystal structure. Consequently, TiB habitus will define interface crystallography.

Possible crystallography of eutectic pair TiB (thin plate) -  $\beta$ -Ti is shown on Fig.7a. Two phases contact at  $\{h0l\}$  TiB  $\parallel$   $\{011\}\beta$  under condition that direction  $[020]$ TiB  $\parallel$   $\langle 111 \rangle\beta$  is oriented along ingot axis. Eutectic pair is arbitrary rotated around this axis. According to this model, stereographic projection of axial  $\{011\}\langle 111 \rangle\beta$  texture will look like that presented in Fig.7b. During subsequent  $\beta \rightarrow \alpha$  transformation, axial texture of beta-phase should transform into axial texture of alpha phase. Twelve variants of Burgers OR would produce texture shown on Fig. 7c. Its comparison with experimental results (See Q07 Progress Report) allows to conclude that not all variants are being realized. More exactly, six of them, which have axis  $\langle 111 \rangle\beta \parallel [020]$ TiB as zone for  $\{011\}\beta$  planes, are preferable (Fig.7d). Preferences of six particular OR variants may be explained by specific properties of interface  $\{h0l\}$  TiB  $\parallel$   $\{011\}\beta$ .

Proposed model is in a good correspondence with results of TEM study [2], where following OR between TiB and  $\beta$ -phase was found:

$$[020]\text{TiB} \parallel \langle 111 \rangle\beta; \quad (002)\text{TIB} \parallel \{011\}\beta.$$

Another finding from high-temperature X-ray study was a conclusion that beta-phase within one eutectic colony was far from being single crystal and consisted of subgrains having disorientation  $\approx 10$  degrees or even more relatively some average orientation (Fig. 5). Such crystallographic community may be identified as eutectic colony. In all colonies studied, average  $\langle 111 \rangle$  direction was approximately perpendicular to ingot axis. Distribution of diffraction intensity was not smooth (continuous), rather discrete indicating that eutectic colonies have cellular structure in bar form (Fig. 8), which was described in special literature related to eutectic transformations [3].

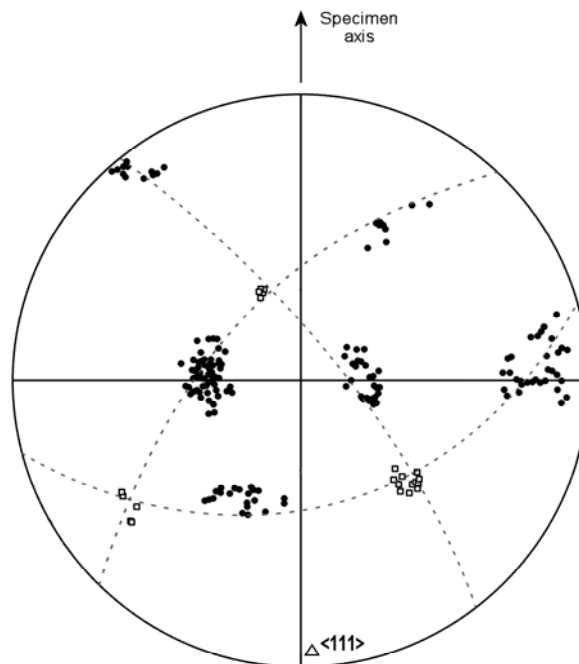

Fig.5. Stereographic projection of  $\{011\}\beta$  (●) and  $\{200\}\beta$  (■) poles in separate eutectic colony.

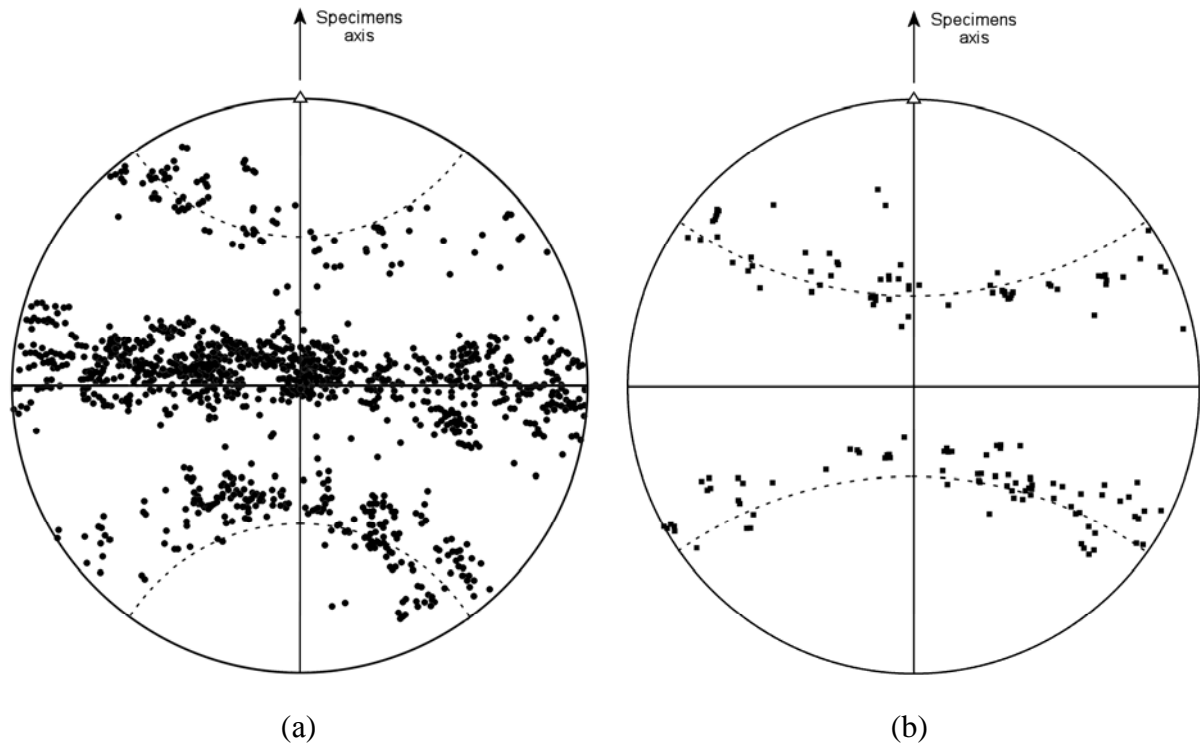
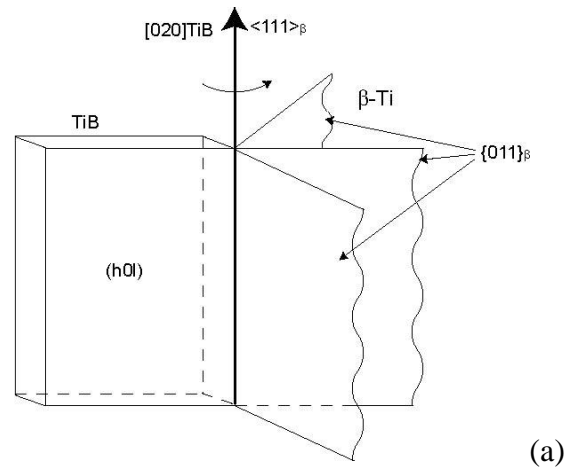
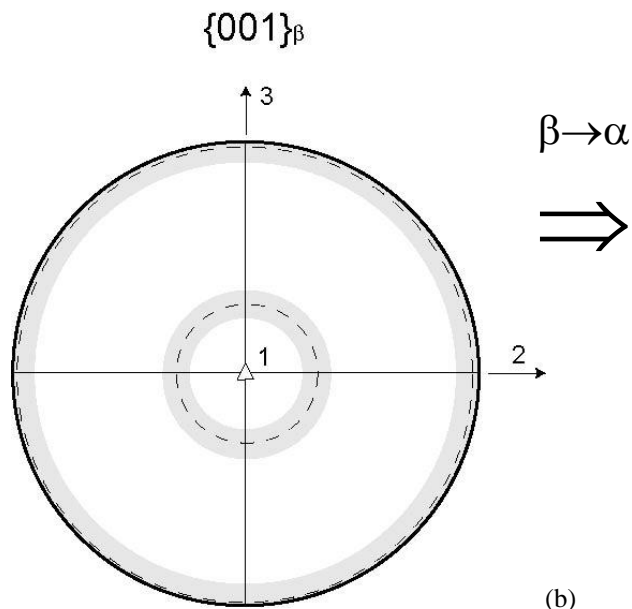

Fig. 6. Generalized stereographic projection of: (a) -  $\{011\}_\beta$  and (b) -  $\{200\}_\beta$  poles, taken from several colonies.



(a)



(b)

$\beta \rightarrow \alpha$   
 $\Rightarrow$

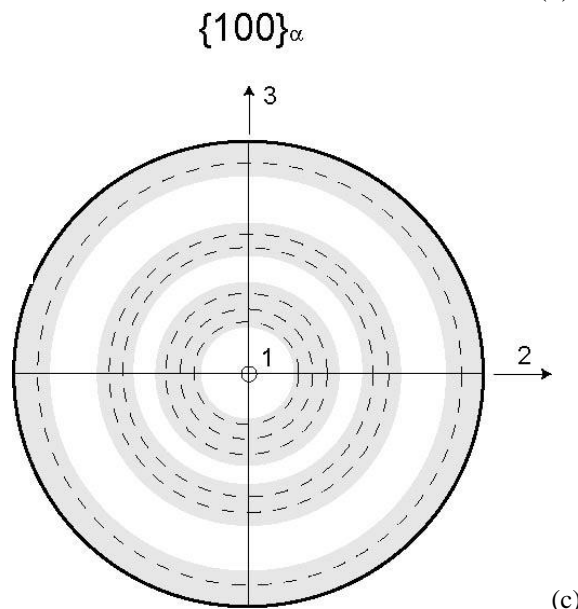

(c)

12 variants Burgers OR

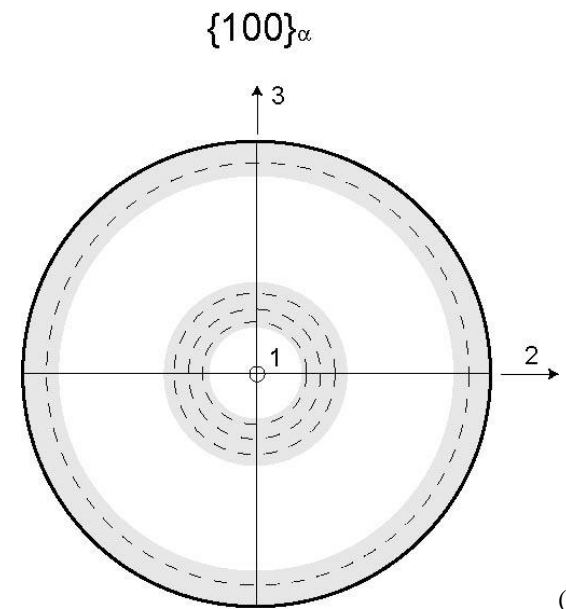

(d)

6 variants Burgers OR

Fig. 7. Modelling of eutectic texture.

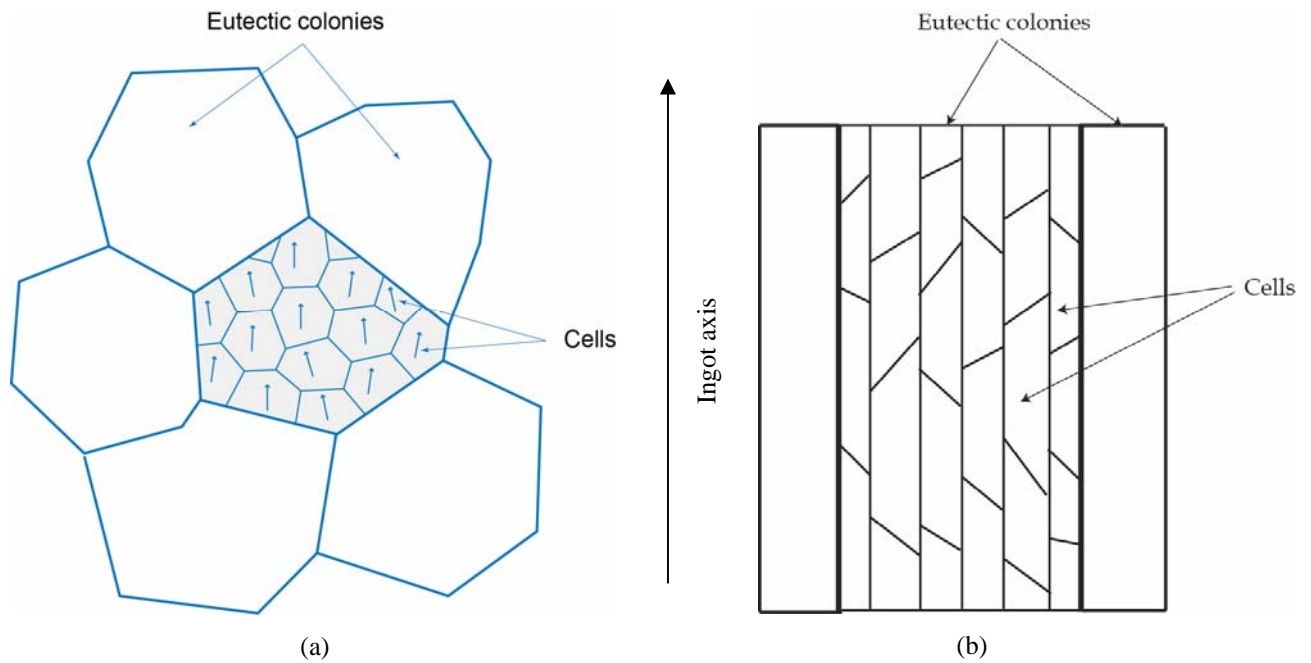

Fig. 8. Schematic structure of eutectic Ti-64-TiB: (a)- transverse direction, (b) – longitudinal direction.

*Activity number and title* 4. Summarizing of the results, preparation of final report and working out of practical recommendations for employment of developed in the project eutectic alloys.

*Works performing during the stage* During the 8<sup>th</sup> quarter works on summarizing and generalization of obtained results was performed.  
 The paper on crystallography of Ti-TiB eutectic is being prepared for publication in Scripta Mater.  
 Presentation for Aeromat Conference (Seattle) is being prepared.  
 Work on final report has started.

**References.**

[1]. A.N. Kalinyuk, N.P. Trigub, V.N. Zamkov, O.M. Ivasishin, P.E. Markovsky, R.V. Teliovich , and S.L. Semiatin, Microstructure, Texture, and Mechanical Properties of Electron-Beam Melted TI-6AL-4V, Mat. Sci. & Eng., **A346**, 2003, #1-2, pp. 178-188.  
 [2]. D.Hill, R.Banerjee, D.Huber, J.Tiley, H.L.Fraser “Formation of equiaxed alpha in TiB reinforced Ti alloy composites”, Scripta Materialia, 52 (2005) 387-392.  
 [3]. Yu.N.Taran, V.I.Mazur, Structure of Eutectic Alloys (Structura Evteticheskikh Splavov, in Russ.), Moscov Metallurgy,1978, 312 p.

**2. Summary of personnel commitments.**

Personnel FWS and NFWS were employed in accordance with Project Agreement with some correction of real working time. Participants were employed in the following activities:

<i>Participants</i>	<i>Activities</i>
Ivasishin	3, 4
Ivanchenko	3, 4
Teliovich	3, 4

Markovsky	3, 4
Garasym	3
Pogrebnyak	3
Savvakin	3, 4
Bondareva	3, 4
Levicka	3
Pischak	3
Molyar	3
Mel'nik	3

### 3. Description of business travel.

During the 8<sup>th</sup> quarter Prof. Ivasishin visited Karpenko Physical and Mechanical Institute, NAS of Ukraine (L'viv) where discussed possibility of special tests (fatigue, etc.) of titanium borides containing materials.

### 4. Current status.

Investigations and organizing works are being performed in accordance with the working schedule.

### 5. Information about major equipment and materials acquired, other direct costs, related to the project..

During reporting quarter the following items were purchased and service were paid in accordance with working plan:

- materials: Interface plate ET1641m (\$304.16) for repairing of X-ray diffractometer, stationery (\$262.56), small consumables (\$69.20);
- other direct costs: payment for different services (in total \$6090).

### 6. Delays, proposals.

No.

**Financial report for quarter 8 (agreed with financial officer) - is added**

*Project Manager*

*O. M. Ivasishin*

*Data: April 27, 2006*

