

REPORT DOCUMENTATION PAGE

Form Approved OMB No. 0704-0188

Public reporting burden for this collection of information is estimated to average 1 hour per response, including the time for reviewing instructions, searching existing data sources, gathering and maintaining the data needed, and completing and reviewing the collection of information. Send comments regarding this burden estimate or any other aspect of this collection of information, including suggestions for reducing the burden, to Department of Defense, Washington Headquarters Services, Directorate for Information Operations and Reports (0704-0188), 1215 Jefferson Davis Highway, Suite 1204, Arlington, VA 22202-4302. Respondents should be aware that notwithstanding any other provision of law, no person shall be subject to any penalty for failing to comply with a collection of information if it does not display a currently valid OMB control number.
PLEASE DO NOT RETURN YOUR FORM TO THE ABOVE ADDRESS.

1. REPORT DATE (DD-MM-YYYY) 22-02-2007	2. REPORT TYPE Final Report	3. DATES COVERED (From – To) 30 May 2003 - 13-Mar-07
--------------------------------------------------	---------------------------------------	----------------------------------------------------------------

4. TITLE AND SUBTITLE Researching the Possibility of Creating Highly Effective Catalysts for the Thermochemical Heat Regeneration and Hydrocarbon Reforming	5a. CONTRACT NUMBER FA8655-03-D-0001, Delivery Order 0004
	5b. GRANT NUMBER
	5c. PROGRAM ELEMENT NUMBER

6. AUTHOR(S) Dr. Alexander L Kuranov	5d. PROJECT NUMBER
	5d. TASK NUMBER
	5e. WORK UNIT NUMBER

7. PERFORMING ORGANIZATION NAME(S) AND ADDRESS(ES) Leninetz Holding Company, NIPGS 212, Moskovsky Prospekt St. Petersburg 196066 Russia	8. PERFORMING ORGANIZATION REPORT NUMBER N/A
------------------------------------------------------------------------------------------------------------------------------------------------------------	------------------------------------------------------------

9. SPONSORING/MONITORING AGENCY NAME(S) AND ADDRESS(ES) EOARD PSC 821 BOX 14 FPO AE 09421-0014	10. SPONSOR/MONITOR'S ACRONYM(S)
	11. SPONSOR/MONITOR'S REPORT NUMBER(S) CRDF 02-9004

12. DISTRIBUTION/AVAILABILITY STATEMENT
Approved for public release; distribution is unlimited.

13. SUPPLEMENTARY NOTES

14. ABSTRACT

This report results from a contract tasking Leninetz Holding Company, NIPGS as follows: The contractor will investigate using a two-stage fuel conversion process for cooling hypersonic air vehicle and engine structures. The two stage process has been shown to significantly reduce fuel coking while maximizing cooling capacity. In the first stage the fuel is reformed to produce methane. The second stage provides additional cooling and reforms the methane into hydrogen. The contractor will develop the catalysts, substrate, and processing procedures required for the two step hydrocarbon steam reforming process. Specifically, for both the stage I and stage II reactors they will (1) develop catalytic materials for low and high temperature operation; (2) develop the plasma spraying technique for applying the catalysts to the substrate material; (3) manufacture samples for testing; and (4) conduct tests to evaluate mechanical and catalytic properties.

15. SUBJECT TERMS
EOARD, AJAX Technology, Fuel Reforming

16. SECURITY CLASSIFICATION OF:			17. LIMITATION OF ABSTRACT UL	18. NUMBER OF PAGES 84	19a. NAME OF RESPONSIBLE PERSON SURYA SURAMPUDI
a. REPORT UNCLAS	b. ABSTRACT UNCLAS	c. THIS PAGE UNCLAS			19b. TELEPHONE NUMBER (Include area code) +44 (0)20 7514 4299

FINAL REPORT

**ON EOARD 024079, DELIVERY ORDER 0004, CRDF RCO-1384-ST-03,
ENTITLED “RESEARCHING THE POSSIBILITY OF CREATING
HIGHLY EFFECTIVE CATALYSTS FOR THE THERMOCHEMICAL
HEAT REGENERATION AND HYDROCARBON REFORMING”**

(From June 1, 2003 to November 30, 2006)

Alexander Leonidovich Kuranov

(Project Manager)

“Hypersonic Systems Research Institute” Joint Stock Company

November 2006

**This work was supported financially by the USAF under the contract with the Civilian
Research and Development Foundation**

CONTENTS

INTRODUCTION.....	3
1. CHEMICAL HEAT REGENERATION AND CATALYTIC HYDROCARBON CONVERSION	4
2. HETEROGENEOUS CATALYSIS ON THE BASE OF FUNCTIONALLY-GRADIENT MATERIALS	5
2.1 FUNCTIONALLY-GRADIENT MATERIALS AND CATALYTIC COATINGS.....	5
2.2 PRIMARY METALLIC SUPPORTER.....	7
2.3 SECONDARY SUPPORTER AND ACTIVE COMPONENT.....	10
3. SELECTION OF TECHNOLOGICAL SCHEMES OF CREATION OF CATALYTIC MATERIAL FOR LOW- AND HIGH- TEMPERATURE HYDROCARBON STEAM REFORMING.....	11
3.1 REQUIREMENTS TO HYDROCARBON CONVERSION CATALYSTS	11
3.2 GENERAL CATALYST TECHNIQUE ON METALLIC SUPPORTER	12
3.3. PLASMA SPRAYING	13
3.4 COLD GAS-DYNAMIC SPRAYING	14
3.5 IONIC-AND-PLASMA COAT MODIFICATION	15
3.6 CHEMICAL IMPREGNATION	15
4. DEVELOPMENT OF THE TECHNOLOGY FOR OBTAINING POWDER COMPOSITION FOR PLASMA SPRAYING OF CATALYSTS.....	16
5. SPECIAL FEATURES OF GAS-THERMAL APPLICATION OF CATALYTIC COATINGS	29
5.1 PHYSICAL PROPERTIES OF THE PLASMA SPRAYING PROCESS.....	34
6. CATALYST SUPPORTERS FOR THE 1 ST STAGE OF HYDROCARBON STEAM REFORMING.....	38
6.1. INVESTIGATION OF SUPPORTER SURFACE PROPERTIES	41
7. SPECIAL FEATURES OF EVAPORATIVE CONDENSATION PROCESSES	45
7.1 MANUFACTURE OF CATHODIC MATERIALS AND SPRAYING OF NI – AL SYSTEM.....	47
8. EXPERIMENTAL INVESTIGATION OF THE CATALYST SAMPLES FOR THE FIRST STAGE OF STEAM REFORMING	54
9. COLD GASDYNAMIC SPRAYING METHOD FEATURES	59
9.1 EXPERIMENTAL INVESTIGATIONS.....	60
10. CATALYSTS FOR THE SECOND STAGE OF HYDROCARBON STEAM REFORMING	70
10.1 METHOD OF HIGH-VELOCITY PLASMA SPRAYING	70
10.2 METHOD OF COLD GASDYNAMIC SPRAYING.....	73
11. APPLICATION OF THE CGDS METHOD FOR MANUFACTURE OF THERMOCHEMICAL REACTORS AND OTHER HEAT-EXCHANGE DEVICES	78
CONCLUSION	82

INTRODUCTION

The analysis of present day tendencies in the sphere of propulsion power-systems creation shows that most attention is being currently concentrated on a search for new types of high enthalpy fuels and the development of economical plants to use them. It is conditioned by a number of factors, such as stringent requirements to propulsion system operating characteristics, economic indexes, toughening of environmental requirements, and the development of principally new approaches in the field of propulsion technology, including design of power plants.

High operating effectiveness of the energy unit in a propulsion system based on the principle of steam reforming of a fuel and chemical heat regeneration is ensured by usage of thermochemical catalytic reactors. To conduct the initial fuel steam conversion and subsequent production of power-intensive hydrogenous fuel mixture, it is advantageous to use heterogeneous catalysts on metallic supporter.

Conducted extensive researches have shown that one of the important factors providing for the efficient performance of catalytic material is the properties of the catalyst supporter. In the general case, catalyst supporters should possess highly developed porous structure fixed relative to the heat-absorbing surface, high thermal conductivity, insignificant hydraulic resistance, high mechanical, vibrating and thermal strength and sufficient service life. However, some specific properties of the catalytic supporter and active component can considerably vary depending on operating conditions of energy device. In particular, of a great importance is temperature of operating. Therefore, it was proposed to develop a succession of catalysts for steam hydrocarbon reforming that could operate in a wide variety of temperatures ranging from 300° C to 1000° C.

The investigations that followed revealed that required catalyst properties could be provided for by creation of gradient-functional catalytic coatings on the working surfaces of generating unit.

We have developed the essentials of the unique technology of plasma and cold gasdynamic spraying of multi-layer functional coatings on the basis of aluminum oxide and various systems of "metal-metal" type, protected by a number of Russian and foreign patents. This technology allows production of highly porous material, featuring its high cohesive strength with substrate surface.

Numerous investigations shown that efficiency, stability and resistance of catalytic material to poisons and carbonization greatly depend on the nature of active components and chemical composition of the supporter, its porous and crystallographic structure. Adhesive properties of the supporter made with the use of plasma spraying are provided by availability of sublayer which has the specific surface not exceeding 5-10 m²/g and binding metal content not less than 3-5 %.

The most reliable means of creation of thermally resistant supporter and stabilization of its structure is usage of modifying additives which delay phase change of oxides.

High porosity is achieved by using for spraying purposes of easily decaying compositions of supporter components such as hydroxides and transition metal salts. Besides, the proposed technique for catalyst supporter production is highly efficient and is in no need of large volume of scarce materials and reagents.

Earlier we have shown that industrial granular catalysts are not suitable for application with transport power installations for many reasons. Therefore our previous efforts in this direction were intended to demonstrate the possibility of creating new catalysts directly applied onto the surface being heated by plasma spraying and other techniques. But we realize that these catalysts were not optimized by their chemical composition, structure, adhesive strength, and operating conditions. Catalyst optimization is closely connected with application technique of catalyst supporter and active component.

The purpose of this work is the use of technology for high-speed deposition of thin films for creation on the surface under heating of gradient-functional coatings featuring high adhesive strength, having preset chemical composition and structure, combining properties of supporter and active component for conducting reactions of hydrocarbon steam conversion in a wide temperature range (300° C - 1000° C). The creation of catalytic active materials with amorphous and microcrystalline structures on the basis of suggested supporter would allow transition to the novel designs of thermochemical reactors for chemical heat regeneration on the world best engineering level.

1. CHEMICAL HEAT REGENERATION AND CATALYTIC HYDROCARBON CONVERSION

Nowadays, conversion of hydrocarbon fuel on board the aircraft is looked upon both as a means of cooling resource increase and as a method to obtain a new fuel with a number of advantages over the initial one.

Endothermic fuel transformation in some chemical processes allows to come closer to hydrogen in terms of cooling resource value. Thus, for example, under steam reforming of hydrocarbons, total heat absorption following physical and chemical transformation of the mixture (water + C_nH_m) makes 8 – 10 MJ / kg.

Another side of hydrocarbon endothermic decomposition process of no less importance, is that it yields synthesis gas with rich content of such active and calorific element as hydrogen. As is known, one of the alternate schemes of propulsion for hypersonic aircraft at M = 5 – 10 can be dual mode hydrocarbon fueled scramjet. Hydrocarbon fuel combustion in supersonic air flow requires continuous firing of the main standard fuel (aviation kerosene) by high temperature chemically active products of chemical reactions flowing out of special gas generator. The latter can function both as the combustion stabilizer and as installation for endothermic fuel transformation. In the last case, it can be thermal protection system for the elements of airframe and combustion chamber.

The two-stage scheme of liquid hydrocarbon fuel transformation (fig.1) under consideration, presupposes obtaining methane as a basic product within first low-temperature phase of the process, as well as some quantity of H₂ and CO₂.



This reaction has insignificant thermal effect. During decomposition methane yields the most quantity of hydrogen, whose presence in the mixture together with carbon dioxide slows down coke formation reaction. At the second high-temperature phase of the process, methane can transform into synthesis gas by three below methods :

- steam reforming



- partial methane oxidation



- carbon dioxide conversion of methane

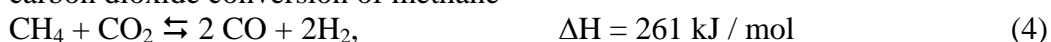

Reactions (2) and (4) are highly endothermic, reaction (3) is low-exothermic. Composition of the obtained synthesis gas in the reaction (2) is H₂ : CO = 3 : 1, in the reaction (3) – composition 2 : 1, and in the reaction (4) – composition 1 : 1.

New way of the reactions (2) – (4) application is their combination. By combining reactions of the steam (2) and oxygen (3) methane conversion into synthesis gas, it is possible to get mixture CO + H₂ composed of H₂ : CO from 2 to 3. Combination of endo-and-exothermic reactions can,

in principle, result in thermoneutral reaction. To achieve this, it is necessary to use mixtures of the following types : $\text{CH}_4 + \text{H}_2\text{O} + \text{O}_2$ or $\text{CH}_4 + \text{CO}_2 + \text{O}_2$.

Autothermic reforming can also be used, where first phase (complete methane oxidation) is methane combustion from the reaction :



During second phase, combined steam-and-carbon dioxide methane conversion is carried out at the expense of the first phase heat. Structurally, both reactors are combined in one apparatus providing for its compactness.

The considered reactions are catalytic ones, some of them have industrial application. But industrial granular catalysts, as a rule, do not meet rigid performance requirements in power installations, especially in aerospace technology. Hence necessity to look for and research on the new high-temperature catalysts and carriers with developed value of specific surface, strength, thermal stability, capable to retain the above qualities in the most demanding circumstances, that is, under unfavorable factors of chemical, thermal ($t = 700 - 1300 \text{ }^\circ\text{C}$) and mechanical (vibration loads and acceleration) impact. Development of the scientific base for catalyst preparation fosters application of the new methods of the purposeful synthesis of catalytically active structures, adjustment of porous structure and distribution of active component, as well as development of mathematical models of technological operations. An example of such catalyst design is the development by our institute of gradient-and-functional catalytic coatings with given chemical composition and structure. On the basis of this technology it is possible to make structures of thermal catalytic units with low hydraulic resistance, enhanced durability and improved operating characteristics.

2. HETEROGENEOUS CATALYSIS ON THE BASE OF FUNCTIONALLY-GRADIENT MATERIALS.

2.1 FUNCTIONALLY-GRADIENT MATERIALS AND CATALYTIC COATINGS

Functionally gradient materials (FGM) refer to new structural materials for objects of modern aerospace engineering, power, electronics etc. They are characterized by gradual, smooth change of a chemical composition, structure and properties (physical, mechanical etc.) on thickness of a product. Their creation resulted from the necessity of providing developing areas of a science and engineering with materials of the high serviceability, enduring action of ultrahigh temperatures (up to 2000 K), extremely wide gradient of temperatures (up to 1000 K) and having high resistance to abrasive wear etc.

Basic directions of FGM development are the following:

1. Research of an opportunity of FGM use as a constructional material
2. Search of new combinations of the materials raising operational characteristics of a product.
3. Research of the basic technology of FGM synthesis, search of their optimum combination, research of influence of technological parameters and properties of an environment on FGM characteristics.
4. An estimation of ability of FGM to a relaxation of thermal stresses and resistance to thermal impact and thermal fatigue at heating by a laser beam, and also research of other properties (mechanical, thermomechanical, physico-chemical, optical etc.).
5. Development of manufacturing techniques of complex configurations from FGM, and also technologies connection of FGM with other materials at installation of designs.
6. Expansion of scopes of FGM use. It is possible to expect that, besides aerospace, FGM will find application in nuclear physics, electronics, optics, medicine etc.

In Russia within the framework of the Federal program « National technological base » complex researches of functionally gradient materials for creation of coverings of catalytic and a magnetic class are carried out. The basic executors of the project is firm "Prometey" and Holding company "Leninetz".

Primary goal of projects under the mentioned program is development of perspective nanomaterials, catalytic materials on a metal basis with amorphous and microcrystalline structure for their use in perspective high-temperature fuel elements, in reactors of conversion of liquid fuel, for obtaining oxide anodes used for electro-extraction of cobalt, nickel; for creation of broadband systems of electromagnetic protection on the basis of amorphous composites; for hardening cutting tool, for improvement of tribological characteristics of friction pairs, for protection of elements of designs in aggressive mediums.

We have great experience of work with functionally gradient materials of catalytic class, including materials for neutralization of harmful emissions of motor transport and the industrial enterprises, for catalytic combustions of fuel (fig.2).

Realization of the present project is carried out in three directions:

- Designing materials of optimum characteristics;
- Their synthesis on the basis of innovational technologies (manufacture of experimental models of FGM);
- Test on the basis of the developed techniques (various estimated tests on which new updating of a gradient of structure of materials will be carried out).

For development of manufacturing techniques of designs from FGM processes of physical and chemical sedimentation from vapor-gas phases, plasma spraying at low pressure, stratifications, sintering and an opportunity of their joint application are investigated. Also researches of the basic technologies of FGM synthesis resulting to reduction of weight of a design and increase of a level of their protection against influence of the aggressive medium are continued.

For realization of process of steam conversion and the subsequent obtaining hydrogenous mixture it is the most expedient to use slot catalytic reactors. One of the types of such reactors is shown in fig.3. The design of a reactor assumes use essentially new functionally gradient coverings both on lateral heat-stressed surfaces of a reactor, and on the internal surfaces essentially increasing catalytic activity of a reactor at its going on a stationary mode of operation.

The material of catalytic reactor is exposed by synergetic influence of all set of factors: temperature, time of contact and composition of a reaction mix, local redistribution of temperature during work, cyclic mechanical and thermal stresses.

Traditional materials with equilibrium structure have practically exhausted the opportunities for ensuring stable activity of the catalyst and prevention from carbon deposition. For creation of competitive products it is the most expedient to use catalytic materials on a metal basis with amorphous and microcrystalline structure.

Use of the most modern methods of high-energy shock-desintegrated treatment of metal materials, cold gas-dynamic spraying, supersonic plasma spraying of functionally gradient powder compositions and vacuum deposition of activators will allow us to create a new class of catalytic materials, capable to increase intensity of process of steam conversion in a direction of movement of gas-vapor mixture by means of gradient increase of catalyst activity.

The executed researches have shown that functionally gradient coverings on the basis of heterogeneous catalytic systems on a metal basis have a number of advantages in comparison with bulk catalysts:

- High mechanical, vibro- and heat stability;
- Small hydraulic resistance;
- High heat conductivity and the porous structure fixed concerning a heat-absorbing surface.

The executed researches have shown that one of a major factor determining effective work of catalytic material is properties of catalytic carrier. Creation of the carrier with optimum properties constantly compels us to seek compromise between its physical characteristics. The special attention is deserved with such characteristics of the carrier, as durability, density, size of a free surface, total volume of porous, the sizes of pores and their distribution on the sizes, the

size of particles and their form, type of crystal modification. It is very important that the basic characteristics of the catalyst corresponded to conditions of realization of process.

2.2 PRIMARY METALLIC SUPPORTER

With the purpose of creation of functionally gradient catalytic materials for realization of process of steam conversion of fuel and chemical regeneration of heat it is the most expedient to use deposition the catalytic carrier and the activator on the initial metal carrier or a substrate.

In connection with requirements of decreasing gas-dynamic resistance, increasing heat conductivity of steam conversion fuel catalysts the great interest get researches on replacement of granular carriers on a basis aluminium oxide by metals and their alloys in the form of fibres, metal tapes, porous blocks etc.

Advantages of catalysts on metal carriers become obvious at their comparison with catalysts on oxide granular carriers in the process of industrial gases cleaning. In comparative conditions catalysts from platinum metals on metal carriers appear more thermostable (maintain overheating up to 800 - 1050 °C), durable, provide deep oxidation at lower temperatures. Due to the streamline form (grids, filters, spirals) they render 2-10 times smaller resistance to a gas stream than granular contacts, and are stronger to mechanical influences. High heat conductivity prevents overheating of all-metal catalysts in exothermal processes.



By an initial look, a configuration, methods of preliminary processing and deposition of active components metal carriers can be divided into groups:

- 1) Wire materials (spirals, grids etc.)(fig.4) ;
- 2) Smooth and corrugated sheets, tapes from the alloys, wrapped in "honeycomb" (fig.5);
- 3) Filters from foamed metals, metal tubes etc (fig.6).

It is conditionally possible to allocate the following functional layers of the catalyst on the metal carrier: a metal substrate (the initial carrier), a porous layer (the secondary carrier) and catalytic active layer (see table 1).

Table 1

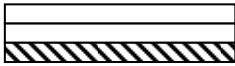
Functional layers of the catalyst on the metal carrier

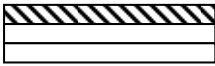
	The name	Destination
	Metal substrate or the initial carrier	Increase of mechanical durability of a design
	Porous layer or the secondary carrier	Creation of high porosity and specific surface of the carrier
	Catalytic active layer containing promoters and activators	Ensuring a specific surface and catalytic activity of the catalyst

The choice of a concrete material for various elements of power devices depends on temperature, a working medium and other conditions of operation. Speciality of aviation consists in increased requirements to reliability of all elements of the design excluding the slightest opportunity of their sudden destruction during work, capable to result in accident.

Direct influence on structure of the carrier and its properties renders of the design catalytic reactor and a choice of a material for its manufacturing.

In this connection we considered an opportunity of deposition of the catalyst on various materials. With this purpose the preliminary analysis of steel marks which can be used as substrates for spraying is carried out.

Effective work of the catalyst during the given lifetime in many respects is defined by serviceability of a substrate in a range of working temperatures at influence of medium - fuels /

steam (for example, $\text{CH}_4/\text{H}_2\text{O}$). The first and obligatory requirement to a material of a substrate is ensuring high adhesion to the porous carrier, deposited by various methods (plasma spraying, ion - plasma spraying, chemical methods etc.) and preservation of durability of adhesion during all operating time of catalytic element.

As a rule the temperature range of work of catalysts depending on type of catalytic reactor makes up (400 - 1100 C), that does inexpedient unification of a material of a substrate.

For mean temperatures (400-700 C) it is expedient to apply alloyed steels, while for temperatures (700 - 1100 C) high alloyed Cr - Ni - Mo steels are required.

At a choice of a metal substrate according to temperature of operation of a reactor the safety factor of a 1,3-1,5 is usually applied. We accepted factor of a thermostability $K=1,4$; in opinion of experts at such factor failure of catalytic block is excluded in case of an emergency.

Influence on a metal substrate of the specified reaction medium is not determining for a choice of a material as the last is practically protected by layers of catalytic coverings (more than 90 %). This circumstance does not show to a material of a substrate of rigid requirements on heat resistance and resistance of gas corrosion.

The determining factor of a choice of a material of a substrate becomes the requirement of heat strength: preservation of a sufficient level of strength properties at the given temperatures during a required interval (long or short-term heat strength).

It is necessary to note that the level of strength properties of a material of a substrate at working temperature depends on stresses which in designs of catalytic reactors are insignificant (pressure of gases is mutually counterbalanced, and influence of weight of a substrate is insignificant because of its small thickness $S < 1 \text{ mm}$).

Proceeding from mentioned reasons, we determined a number of steels and alloys which can be considered as substrates at work on deposition of catalytic coverings and the subsequent bench tests in the conditions simulating work of catalytic elements of systems of steam conversion of methane and chemical regeneration of heat (see table 2).

The materials answering the requirements of thermal strength in the field of temperatures of catalyst operation, are high-alloyed steels and alloys austenitic and ferritic classes. It is known that steels of such type have rather low heat conductivity at normal temperature. Catalytic substrate should have high heat conductivity. However it is necessary to take into account, that heat conductivity of high-alloyed steels intensively rises with growth of temperature and at $t > 700 \text{ }^\circ\text{C}$ reaches a level of carbon steels.

Taking into account small thickness of substrates and accordingly small time of their heating up to working temperatures, the factor of heat conductivity can be omitted.

Taking into account all above-stated, it is possible to draw a conclusion that for a material catalytic substrates a number of industrial types of steels and alloys can be used. We recommend the following materials:

- ferritic steel of mark X15Ю5 - for $t \leq 1000 \text{ }^\circ\text{C}$,
- austenitic steel X18H10T - for $t \leq 900 \text{ }^\circ\text{C}$,
- Heat resisting nickel alloy XH55MBИ - for $t \leq 900 \text{ }^\circ\text{C}$,
- Heat resisting chrome-nickel alloy X20H80T-for $t \leq 1200 \text{ }^\circ\text{C}$.

The basic physico-mechanical characteristics of materials are submitted in tab. 3.

Table 2

The preliminary choice of marks of materials of metal substrates of catalytic elements

Mark of steel	Application	Semifinished items	Adaptability to manufacture
X15H9Ю X15Ю5 X25Ю5	The details working in contact to fuel at 1000°C (short-term) and at 900°C (long term)	Bars, forgings, sheets	It is well welded by all kinds of welding, it is deformed in cold and hot conditions
X17H5M3 X16H6 X15H7ЮM2	Covering of details of an internal set, the units of engines working at temperature up to 550°C	Bars, sheets	It is well welded by all kinds of welding, it is deformed in cold and hot conditions
X17Г9АHЧ	Details of propulsion installations, including welded, working in contact to fuel at temperature up to 800°C	-	It is well welded, deformed in cold and hot conditions
0X18H10 0X18H9 02X18H10T	Details of communications of hot gases, exhaust collectors and branch pipes of engines. They are stable against oxidation in air and in products of combustion of fuel at temperatures from 700°C up to 900°C	Bars, forgings, sheets	— " —
3X13H7C2	Valves of piston engines; it is stable against oxidation in the air medium at temperatures up to 1000°C	Bars, sheets	It is deformed in cold and hot conditions
X23H3 X23H18 X25H16Г7AP	The oven equipment working at temperatures up to 900°C. They are stable in an atmosphere of air at temperatures up to 1100°C	Bars, sheets thickness 0,8 - 25 mm	— » —
4X14H14B2M X14H14CB2 M	Outlet valves of the engines working at 800 - 1000°C; good resistance of gas corrosion at temperatures up to 1000°C	Bars, forgings	It is well welded, deformed in cold and hot conditions
X20H80T	Flame tubes of the combustion chamber and other details working at temperatures up to 1100-1200°C	Tape, forgings, sheets, pipes	— » —
XH55MBИ	Cases of gas reactors and the pipelines working at temperatures up to 1000°C	— » —	— » —

Table 3

Physico-mechanical properties of the chosen materials

Mark of steel	Mechanical characteristics at normal temperature		Ultimate of strength σ_{τ}^T , kg/mm ²	Creep strength $\sigma_{0,2\tau}^T$, kg/mm ²	Thermal conductivity λ_T , cal/cm·sec·°C	Heat resistance, an additional weight at T° with g/m ² h
	σ_B , kg/mm ²	δ , % 5,63√F				
07X18H10T	56-66	40-65	$\sigma_{1000}^{760}=4,00$ $\sigma_{1000}^{815}=2,60$	$\sigma_{0,2/100}^{815}=5,0$	$\lambda_{100}=0,039$ $\lambda_{900}=0,068$	1100°C-3,3 1000°C-1,2 900°C-0,2
X15IO5	30-40	30	$\sigma_{1000}^{800}=0,40$	$\sigma_{0,2/100}^{800} < 0,3$	$\lambda_{700}=0,041$	-
XH55MBIЦ (ЧC-55)	65	45	$\sigma_{1000}^{800}=6,0$	$\sigma_{0,2/100}^{800}=4,0$	$\lambda_{700}=0,057$ $\lambda_{900}=0,067$	800°C-0,04
X20H80T	73-78	40	$\sigma_{1000}^{1200}=2-3$	$\sigma_{0,2/100}^{900}=3,8$	$\lambda_{900}=0,076$	1200°C-0,507-0,665

According to conditions of process (temperature 600-900 °C, medium - hydrogen and steam), proceeding from the analysis of marks of the heat resisting alloys we chosen alloys X20H80, 07X18H10T with working temperature up to 1000-1100 °C, which can be used directly as a sheet or net filling slot volume of the reactor.

The chosen materials have a high level of plastic characteristics at room temperature that provides their adaptability to manufacture at preparation of a foil or a tape with thickness > 0,05 mm, and also a necessary level of durability at working temperatures of the catalyst. Besides they are mastered in manufacture of the metallurgical and metalcutting enterprises and delivered as a tape, a sheet, cold-drawn pipes.

2.3 SECONDARY SUPPORTER AND ACTIVE COMPONENT

Development of catalytic materials on a metal basis includes two basic stages: obtaining durable high-porous carrier (development of a powder composition and obtaining of a volume - porous functionally gradient covering) and creation on its surface effective catalytic active composition (a choice of catalytic active system in the given process and development of technology of its deposition on the porous carrier).

Let's stop at concrete stages of this work.

We have developed a base technology of creation of high-porous carrier on a metal substrate by a method of high-speed plasma spraying for clearing systems of exhausted gases of the industrial enterprises and motor transport. This technology is well combined with modern methods of deposition of activators, for example, by magnetron and ion – plasma spraying, and also by various methods of chemical impregnation, allowing to obtain highly active microcrystalline and amorphous materials.

According to the concept of creation of catalysts developed by us for systems of steam conversion of fuel and chemical regeneration of heat the use of aluminium and nickel as metal binder should provide adhesion of the carrier with a substrate. Deposition of aluminium hydroxide will allow us to obtain a surface with high porosity, introduction rare-earth (La, Ce, Nd) and transitive metals (nickel and chromium oxides) will lead to stabilization of low-

temperature aluminium oxides and ensuring catalytic activity of a material.

Distinctive feature of the technology of plasma spraying developed by us is the opportunity of obtaining of the functionally gradient coverings that is provided by system of dosers.

The analysis of the scientific literature and earlier researches show that for catalysts of steam conversion of hydrocarbons the best carrier is the γ - Al_2O_3 . It has a structure of defective spinel of cubic system in which the ratio of vacant places in octa- and tetra-positions makes up 3.

All modifications of aluminium oxide, except for α - Al_2O_3 , and in the greater degree γ - Al_2O_3 , owing to their structure are capable to stabilize in octa- and tetravacancies active metals of transitive groups and promoters, creating enough large surface of the activator on γ - Al_2O_3 with formation at its presence of more fine crystals and partial introduction of the activator in tetra-vacancies which at other carriers are absent.

Additional stabilization of the carrier is necessary for high-temperature processes of the second step of fuel conversion with the purpose of maintenance of an invariance of structure and properties of catalytic material.

The most reliable way of creation of active thermally stable carrier on basis Al_2O_3 is stabilization of its structure by introduction in low-temperature modification of aluminium oxide the elements, which not forming with it new phase compounds or are implanted into superficial oxide vacancies, or envelop its surface and hinder phase transition in α - Al_2O_3 . There are data that stabilization of transitive forms of aluminium oxide is possible up to 1200°C .

The executed analysis of similar carriers structure and opportunities of using of powder compositions for plasma spraying has allowed to reveal the most perspective modifying additives slowing down phase transformations of aluminium oxide. Such compounds are first of all oxides of rare-earth metals (La, Ce, Nd), oxides of titan, zirconium, silicon, alkaline and alkali-earth metals (Ba, Sr). In addition the last provides stable activity of the catalyst in conditions of steam fuel conversion and prevents from carbon formation.

It allows to draw a conclusion about expediency of use for the decision of a task of the system $\text{Al}/\text{Ni}/\text{Al}(\text{OH})_3/\text{REM}/\text{Cr}_2\text{O}_3$.

Considering the most effective activators from number of rare-earth elements, transitive and noble metals we undertook attempt to unite technical and technological tasks: simultaneous introduction of the components having both stabilizing and active function. Among considered catalytic systems the most perspective system for steam conversion of fuel and chemical heat regeneration is one on the base of nickel - chrome alloys.

Saturation of layers by activators is provided by methods of vacuum deposition (magnetron and ion - plasma spraying) and chemical impregnation.

There is a row catalysts activity, and the maximum corresponds to metals of platinum group - Pt, Pd, having the activity that exceeds activity of others by two orders. Then the most active oxides of transitive metals Co_3O_4 , MnO_2 , CuO and Cr_2O_3 follow.

For creation of functionally gradient porous catalytic material it is the most expedient to use for plasma spraying the following systems: as an adhesive layer system Al , $\text{Ni}/\text{Al}_2\text{O}_3$, as an intermediate layer $\text{Al}_2\text{O}_3/\text{CeO}_2/\text{La}_2\text{O}_3$, as a catalytic layer $\text{Al}_2\text{O}_3/\text{CuO}/\text{Cr}_2\text{O}_3$; $\text{Al}_2\text{O}_3/\text{CuO}/\text{MnO}_2$; $\text{Al}_2\text{O}_3/\text{Co}_3\text{O}_4$.

3. SELECTION OF TECHNOLOGICAL SCHEMES OF CREATION OF CATALYTIC MATERIAL FOR LOW- AND HIGH- TEMPERATURE HYDROCARBON STEAM REFORMING

3.1 REQUIREMENTS TO HYDROCARBON CONVERSION CATALYSTS

Owing to temperature variations at the low-and high-temperature hydrocarbon conversion, different requirements are made on the catalysts.

General requirements to the 1st stage catalysts are as follows :

- high activity in liquid hydrocarbons and industrial fuels gasification reactions;
- low activity in coke-formation reactions;
- large specific surface of catalysis needed at low temperatures;
- caking-and-poisoning resistance;
- given life time if regeneration process is to be carried out;
- ability to acquire any shape that ensures low hydraulic resistance of the reactor.

At high temperatures (2nd stage) required for getting hydrogen, there is no need for high activity as chemical reaction velocities are high enough and dispersion of the active components should not be too thin. Otherwise, caking of metal occurs due to high temperatures. Instead, there are very strict requirements to the catalyst mechanical rigidity, so that they withstand high temperature effects.

Proceeding from general terms and conditions of the considered process in the facilities of chemical regeneration of heat, the catalysts under development are to meet following technical requirements :

1. metallic substrate – stainless steel;
2. porous supporter:
 - chemical and phase composition :
 - substratum : low temperature alumina;
 - alumina (α - Al_2O_3) : < 5 %;
 - catalyst additives : up to 15 %.
 - coating thickness : 40 - 70 μ m
 - specific surface : 40 – 80 m^2/g (I st.); 10 – 20 m^2/g (II st.)
 - pores size : 10^{-6} - 10^{-4} mm (10 – 1000 Å);
 - open porosity : > 20 %
 - thermoresistance and thermostability in medium H_2 and H_2O : up to 600°C (I st.); up to 1000 °C (II st.);
 - coating application technology has to provide for possible introduction of additives enhancing thermal stability and firmness of the supporter (such as, e. g., La, Ce, Si, Mg compounds and so on);
 - adhesion strength of coating with substrate : not less than 0,6 kg/cm^2 ;
 - thermocyclic strength : 100 thermal changes;
3. active component – Ni (Pt) :
 - activity of catalyst under development must be commensurable with activity of granular catalyst for steam conversion of hydrocarbons;
 - catalyst selectivity has to provide for minimal surface carbonization;
 - catalyst life time: 500 hours minimum;

Manufactured laboratory test samples are to be placed in the reactor space with $d=30$ mm and $h=100$ mm.

3.2 GENERAL CATALYST TECHNIQUE ON METALLIC SUPPORTER

High-porous supporter technique for systems of fuel steam reforming lies in application of powder composition consisting of aluminum, Al hydroxide and promoting additives onto metallic substrate.

According to our conception of catalyst development, use of aluminum and nickel as matrix metal has to provide for supporter's adhesion with substrate, and combined with them application of Al oxide will get us high-porosity surface. In addition, introduction of rare-earth elements (REE) oxides (lanthanum, cerium, neodymium) and transition metals (nickel oxide and chromium) will enable us to stabilize low-temperature alumina and ensure catalytic activity of the material.

Of practical interest is research on possibilities of creation complex oxide catalyst systems by using plasma, magnetron and ionoplasma spraying technique. Active component of such systems consists of oxygen-based compounds of two and more elements.

These catalysts due to their properties often turn to be very efficient : by making their composition more complex we can enhance activity, thermal stability, mechanical strength and other features to a significant degree.

The following considerations have conditioned catalytic material selection technique:

1. Need for materials possessing the above set of properties and providing for highly efficient process running, as well as sufficient porosity and high coating adhesion with the surface.
2. Possibility to obtain optimal structure of catalytic material (both amorphous and microcrystalline) with the help of magnetron and ionoplasma spraying techniques
3. Possibility to smoothly adjust various modes of technological process depending on required properties of the material.
4. High efficiency and environmental safety of technological process.

Having thoroughly analysed composition and structure of frequently used catalysts we have worked out the concept of functionally gradient catalytic supporter where alteration of coat composition results in the change of its qualities.

General technological scheme of creation of gradient-and-functional catalytic material needed for realization of hydrocarbon steam reforming includes the following sequence of technological operations (Fig. 7):

- preparation of initial materials inclusive of chemical and ultrasonic treatment of metallic supporter surface; disintegration of primary powder materials, their drying and dispersion; mechano-chemical synthesis of catalytically active oxide power composition on the base of transition and rare-earth metals;
- high-velocity plasma or cold gas-dynamic spraying of powder composition onto metallic supporter;
- application of activator (magnetron or ionic-plasma modification, chemical impregnation);
- formation of catalytic element, inclusive of catalytically active material profiling, assembly and thermal treatment.

Let us consider separate technological operations.

3.3. PLASMA SPRAYING

Earlier we had succeeded in developing of basic technology of high-porosity supporter creation by high-velocity plasma spraying, as applied to catalytic materials for gas purification systems of industrial enterprises and motor transport.

In our project this technology will be modified to meet requirements to the supporters of hydrocarbon low-temperature steam reforming. High-velocity plasma spraying of catalyst supporter onto metallic substrate goes well with up-to-date activator application techniques, such as ,e. g., magnetron and ionic-plasma spraying, as well as various methods of reactive impregnation.

Layer-after-layer plasma spraying technology allows (by making solid adhesive coat) to introduce easily-decomposed compounds of transition metals and rare-earth elements (REE)for stabilization of low-temperature alumina and simultaneous catalytic activation of coating, to provide for high porosity of active layer.

The idea of plasma spraying is that powders of aluminum and Al hydroxide are transferred by high-temperature plasma jet onto metallic heat-resistant tape, with AL hydroxide dehydrating under temperature impact and turning into alumina.It is consecutive decomposition of Al hydroxide that ensures developed surface. For maximum transfer of hydroxide to coating the powder is supplied on plasmatron shear to the remote zones of plasma jet.

Feeding of the sprayed material consisting of aluminum powder and powder composition can be executed either jointly from one dozer or separately using several dozing devices.

Fatless and cleaned metallic tape made of heat-resistant steel is tightly wound on plasma unit drum. Powder composition is poured into powder feeders included in plasma unit set.

Deposition of powder materials on heat-resistant tape is executed by plasma spraying technique, with intensive cooling of the sprayed surface by compressed air. To obtain cermet coating air plasmatrons are used. Compressed air serves as plasma-forming and powder material-transporting gas.

To obtain necessary coatings low-temperature plasma is used. It is a gas with highly-ionized constituent particles that is formed under atmospheric pressure. The most important merit of this plasma is its ability to transfer temperature and ensure high-velocity spraying.

The set of available equipment for plasma spraying "Plasma-1" (Fig.8) consists of plasmatron power-supply system, organs of control, blocking, signalling and systems of sprayed material feeding, plasmatron gas-supply and cooling.

One of the features of plasma spraying technique under development is synchronous use of dosers providing for functional and gradient deposition of adjustable composition. Owing to this circumstance, plasma spraying ensures :

- creation of solid adhesive layer;
- stabilization of low-temperature alumina;
- high porosity of the secondary supporter (carrier);
- introduction of catalytically active oxides of transition metals causing catalytic activity of the material.

3.4 COLD GAS-DYNAMIC SPRAYING

And now, let's dwell in length on application of supersonic cold gas-dynamic spraying intended to obtain catalytic coatings.

High-temperature two-phase flows are used in some known gas-and-thermal methods of spraying powder materials onto substratum. Coat formation takes place under interaction of melted (or very close to this state) particles of sprayed material with the substratum. To achieve this effect, high-temperature gas flows are used. For example, the temperature of low-temperature plasma makes, as a rule, no less than 2 500 °C. Such flows are obtained by means of expensive and rather complicated from the technical point of view high-temperature equipment such as plasmatrons, gas-fired burners, detonation guns and so on.

In the process of transfer, complicated physical and chemical interactions can take place, including formation of oxides, nitrides, carbides, decomposition of some materials, structural changes, et cetera, considerably reducing quality of

coating. That is why the intensive search for innovative technological processes go on, the processes that would allow spraying of films with controlled properties and under significantly lower temperatures, not exceeding 400 – 600°C. Moreover, to ensure high adhesion, it is necessary to considerably increase velocity of heterophase flow. One of such methods is technology of "cold" gas-dynamic spraying. It is going to be modified in order to get coats, meeting specific requirements of catalysis.

The essence of the method lies in application of metal powders at the treated surface by means of supersonic air flows. Powder material represented by fine-dispersed particles gets accelerated in the supersonic nozzle by the compressed air flow, and is forwarded directly to the surface to be coated.

The particles are transferred in a "cold" state. Their heating is accomplished mainly at the expense of kinetic energy transformation into thermal one at the time of co-strike against barrier. It enables to obtain coatings absolutely adequate to the sprayed powder as regards composition.

Installation for coatings obtaining by means of "cold" gas-dynamic technique consists of the following principal parts (Fig.9):

1. compressed air cylinders

2. air purification system
3. ohmic heater of working gas (air)
4. Laval nozzle
5. installation control panel
6. feeders (dosers)

Compressed air from purification system is supplied to the chamber of ohmic heater. In the chamber, air is heated to the operating temperature and is fed into supersonic nozzle. Sprayed powder enters nozzle area and is captured by passing air. At the supersonic nozzle outlet, high velocity heterophase jet of mixture "hot air + powder" is formed.

The factors of the utmost importance in the process of cold gas-dynamic spraying are gas flow velocity, as well as temperature and velocity of the sprayed particles which will vary in the course of experiments on the catalytic coatings development.

3.5 IONIC-AND-PLASMA COAT MODIFICATION

For application of Ni-Cr system activator, ionic and plasma spraying in controlled gaseous medium can be used. The essence of this technique lies in vaporization of metal (or alloy) atoms- under plasma flow impact- from target surface and their selected deposition on the supporter. Spraying of metal coatings takes place in vacuum. To obtain oxide-based coatings, oxygen is introduced during the process. Spraying is carried out as per condensation of substance method when vaporization is executed by voltaic arc in vacuum with prior surface cleaning by ionic bombardment (KIB method).

The most expedient spraying technique is when either single combined target of Ni-Cr alloy is used or some targets made of nickel, chrome or cobalt. In this case it is possible to get a coating of given composition as their separate control can be ensured and, correspondingly, coatings of different compositions. Targets for ionic and plasma spraying represent truncated cones of h-45mm and diameters of low and upper bases 60mm and 55mm accordingly. The "Bulat-6" single-chamber vacuum unit for ionic and plasma spraying is equipped with three target sockets and gas leaks.

Targets layout in the unit's working chamber is shown in Fig.10.

The unit is designed for different operating modes : with one, two or three cathodes. To obtain coatings containing nitrides, oxides, carbides of the spraying metal, reactive gases such as nitrogen, oxygen acetulene are supplied into the chamber. Top residual pressure in the working chamber makes no less than 1×10^{-4} mm Hg. Speed of film deposition can be adjusted in a wide range by changing number of cathodes used and arc current within 50 – 150 A diapason.

Ionic and plasma spraying technology ensures obtainment of multifunctional coatings, quite unique as to their properties.

A feature of evaporating condensation technology under development inclusive of ionic-and-plasma and magnetron spraying is the use of, firstly, system of cathodes enabling us to get stoichiometrical coat composition and, secondly, heterophase flow focus&deviation system excluding drop phase formation.

At the same time ionic-and-plasma and magnetron spraying also ensures :

- creation of amorphous and micro crystalline coat composition;
- subsequent application of activators leading to considerable enhancement of the material catalytic activity as compared to that of carrier; deposition of coat 2 – 5 micron of thickness without noticeable decrease of material dynamic properties.

3.6 CHEMICAL IMPREGNATION

Application of active component techniques at the carrier in the form of granules are well known. They are: moisture capacity impregnation, dipping, sprinkling, impregnation with boiled down solution, impregnation with salt melt. Below is a brief description of these processes together with their advantages and shortages.

Moisture capacity impregnation: porous carrier is impregnated with the solution of active component which is fully absorbed by carrier's weight. Advantages: absence of waste water, exact knowledge of active component concentration. Shortages: repeated impregnation, intermediate thermal treatment.

Dipping: the carrier is submerged into excess (1 : s = 2-10:1) of impregnated solution and kept there some time, while mixing, under specified temperature. Advantages: simplicity of the technique and getting homogeneous as to the composition catalysts. Shortages: selective sorption of separate components on the carrier; necessity to know dependability of active component content on salt concentration in the impregnating solution; heavy losses of active components; problems with utilization of spent solution.

Sprinkling: the carrier is sprinkled with active salts solution which is performed while mixing carrier's granules under heating. Advantages: no losses of the impregnating solution, the method is material-saving and practically wasteless.

Shortages: it is very difficult to get homogeneous product with reproductive properties.

Impregnation with boiled down solution: the carrier is impregnated in the insignificant excess of solution with consequent boiling down. Advantages: the method is wasteless and very simple from technological point of view. Shortages: distribution of active component, as a rule, in a thin surface layer of carrier's granules; reduction of strength properties of catalyst granules as compared to the carrier.

Impregnation with salt melt: the carrier is submerged into salts melting that contains active components in a specified ratio while mixing. Advantages: homogeneous catalysts yield. Shortages: necessity to know dependability of active element content on salt concentration in the impregnating melt; heavy losses of active components; problems connected with utilization of spent melt.

Selection of this or that impregnation technique, as applied to our thin-layer carriers, will be made in the course of experimental test.

Activator chemical deposition technique ensures :

- significant increase in active components concentration;
- deposition on catalytic material, if need be, of such compositions that are not viable from economic point of view if we are to apply them by another methods;
- considerable reduction of activators consumption.

4. DEVELOPMENT OF THE TECHNOLOGY FOR OBTAINING POWDER COMPOSITION FOR PLASMA SPRAYING OF CATALYSTS

In the initial powder material over its 60 % has dispersion within 100 – 150 μm range. The results of the preliminary investigations showed that for creation of a porous structure by plasma spraying method, the optimal value of powder dispersion lies in the range from 50 to 80 μm . That is why, the solution of the two tasks was required: to develop the technique of powder material preparation that would possess a specified dispersion and bring the initial powder materials into catalytically active state needed for subsequent plasma spraying.

Efficient method of mechano-chemical synthesis on impact-and-disintegration unit (IDU) (fig.11) is going to be used for homogenizing and activating of the selected powder composition. Principle of IDU-treatment is based upon brief and highly energetic impact on powder material. It triggers in the material high-velocity micrometallurgical processes leading to phase and structural changes, inter-diffusion of elements and formation of inter-metallic compounds. Treated powders are transferred from dozers to activator chamber where they form particles counter-flows with the help of rack rotors revolving towards each other at 20 000 rpm speed. Under impact of 450 g intensity the particles disintegrate to several microns and less. At the moment of impact, stored kinetic energy turns into inner one ensuring particle transition into molten state. Subsequent interaction of molten particle with cold rotors and activator' chamber body provides for high-velocity cooling, with ultimate fixation of material structure. Adjustment

of the treatment speed and powders initial makeup ensures acquisition of materials with required chemical and phase composition. The experimental investigations show that top efficiency is attributed to multi-cycle shock-activating treatment of nickel-aluminum alloys at the total speeds of the rotors rotations from 12 000 – 15 000 rpm.

The majority of particles (species) are of spherical shape. That ensures high uniformity of particles penetration in plasma flow at spraying and allows to enhance homogeneity of catalytic layer structure.

In general, it can be stated that IDU-treatment makes it possible to improve material structure in the way we need, and obtain powders of the preset dispersion and phase composition with enhanced technological activity.

Following impact-and-activator treatment powders undergo diffusion into fractions with the help of standard sieves. The powders obtained comprise up to 70 % particles 40-63 μm size, and then are used in catalytic layer plasma application.

For the preliminary selection of basic components of powder oxide composition, the initial powder materials have been thoroughly investigated. The powders phase, chemical and granulometric composition and physical-and-chemical properties have been determined, including bulk density, humidity, as well as quality of mixing control. The optimal powder rate at weighing was also determined. A number of initial powder properties is presented in Tables 4 – 6.

Table 4**Granulometric composition of the initial aluminum hydroxide**

Particle size, μm	Fraction of total mass, %
> 200	0,53
200-160	2,23
160-100	31,68
100-63	55,85
63-50	0,99
< 50	8,72

Table 5**Thermal stability of transitional metal oxides**

Oxide	Maximum temperature, $^{\circ}\text{C}$
Co_3O_4	900-950
CdO	700
WO_3	800
V_2O_5	670
MnO_2	535
CoO	1795
ThO_2	2800
CeO_2	2500
Cr_2O_3	2266
Al_2O_3	2050
Fe_2O_3	1565
FeO	1369
Fe_3O_4	1594
Mn_2O_3	1080
Mn_3O_4	1564
MnO	1785

Table 6**Chemical composition of the base powder mixture of rare-earth elements oxides**

№	Compound	Fraction of total mass %
1	Ln_2O_3	21±2
2	CeO_2	50,0±0,5
3	Nd_2O_3	12,83±0,5
4	Pr_6O_{11}	6,97±0,5
5	Sm_2O_3	No more 1,33
6	Eu_2O_3	0,16
7	Gd_2O_3	0,13
8	Ho_2O_3	0,06
9	Yb_2O_3	0,06
10	Y_2O_3	0,06
11	Others	1,57

For preparation of test samples of the catalyst material for the 1st and 2nd stages of the fuel steam conversion, a trial batch has been prepared inclusive of the four versions of powder composition with various weight ratio of the components (base: aluminum, nickel, aluminum hydroxide; modifying additives: rare-earth and transitional metals oxides – Table 7)

Table 7**Composition of powder compounds**

Catalyst material	Chemical composition of powder compound, % of weight				
	AL	Ni	Al(OH)3	REM	TM
Fuel steam conversion, 1st stage	1	4	90	2	3
	4	1	90	1	4
Fuel steam conversion, 2 nd stage	5	15	65	5	10
	2	18	70	5	5

Fitness of the developed powder compounds for plasma spraying will be determined by experimental deposition of catalytic coatings using the basic process throughout next stages of work. In accordance with the experimental results, the procedure of mixture obtainment will be corrected and ultimate composition of powder compound for hydrocarbon steam reforming of both stages will be determined.

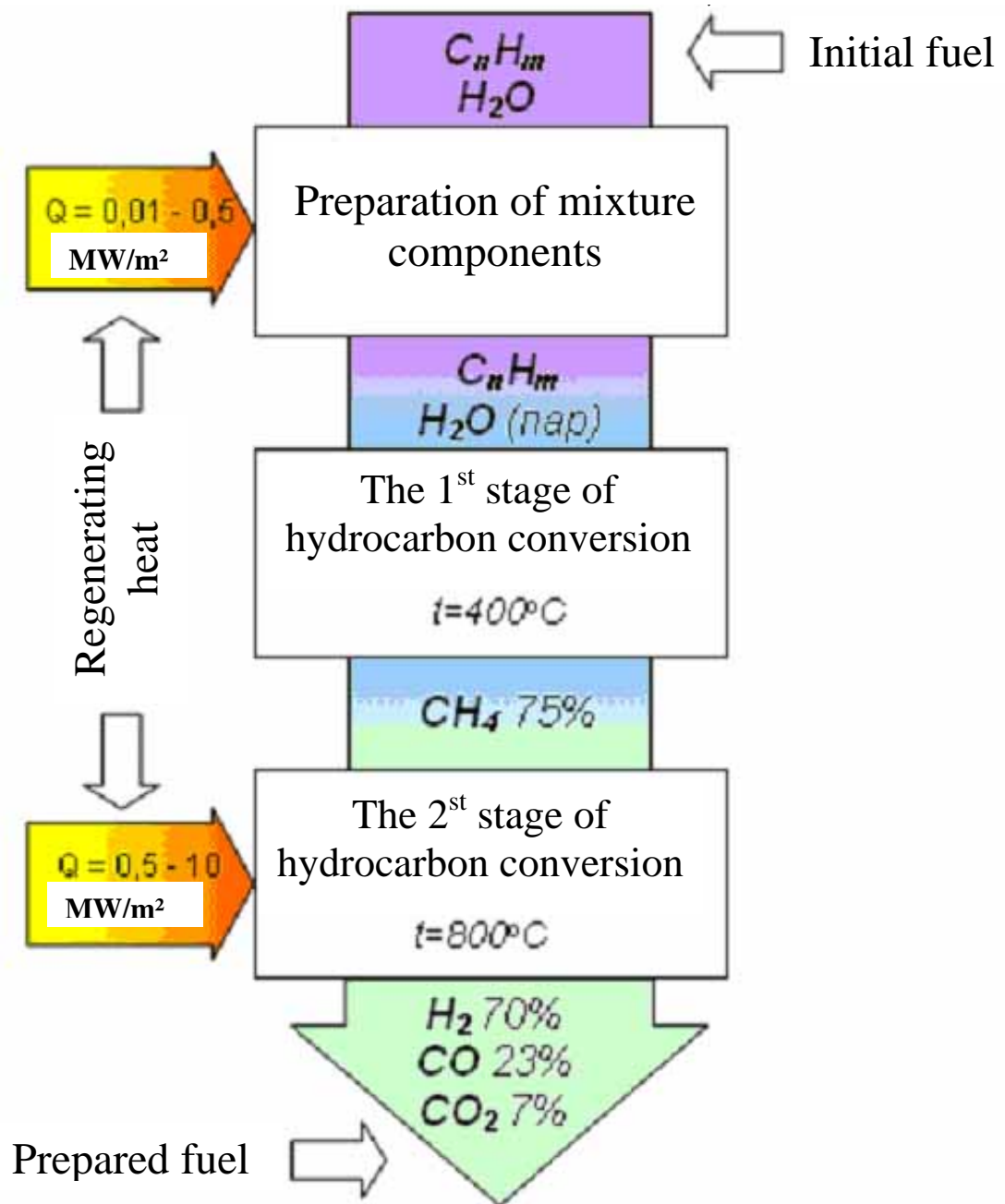

Fig.1 Two-stage scheme of steam hydrocarbon reforming

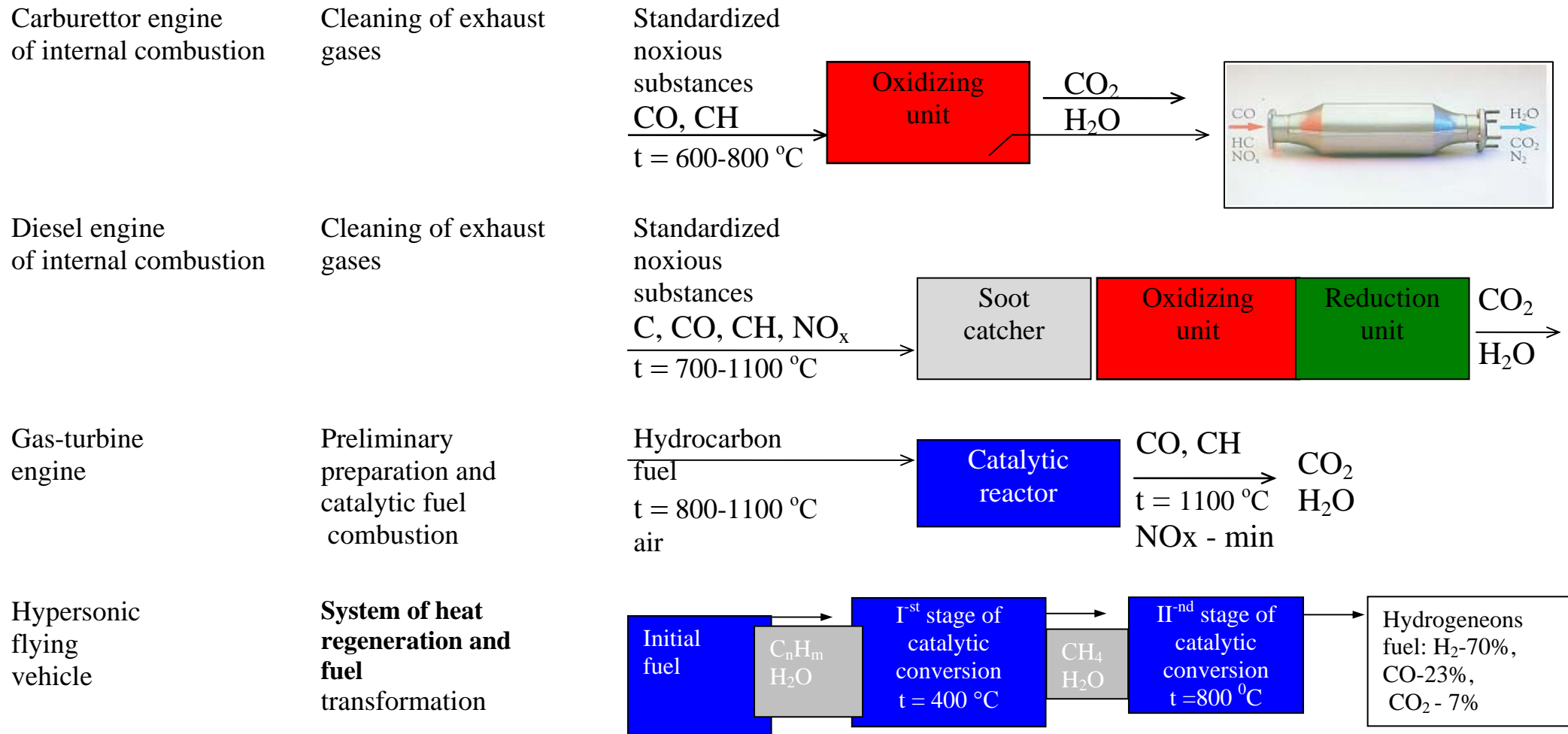

Fig.2 Application of functionally gradient materials in various energetic device

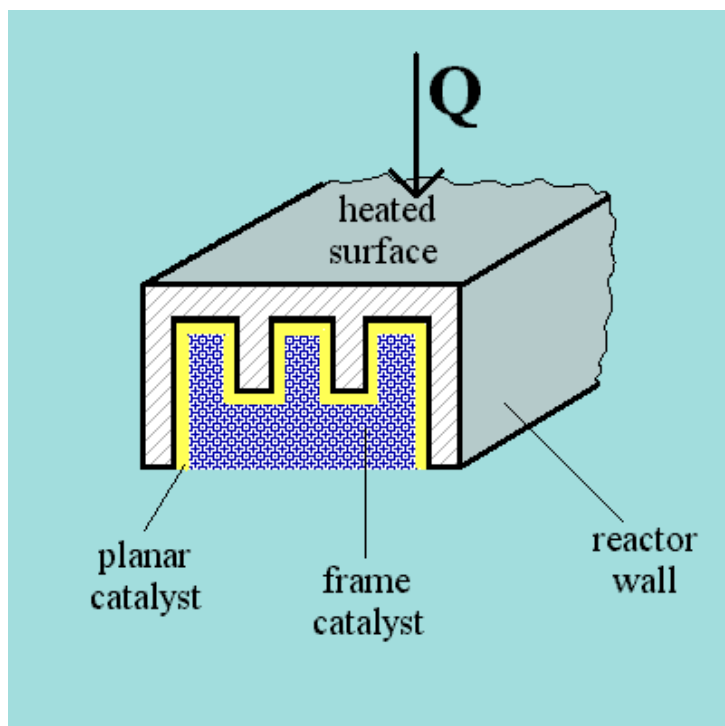

Fig.3 Fragment of catalytic reactor

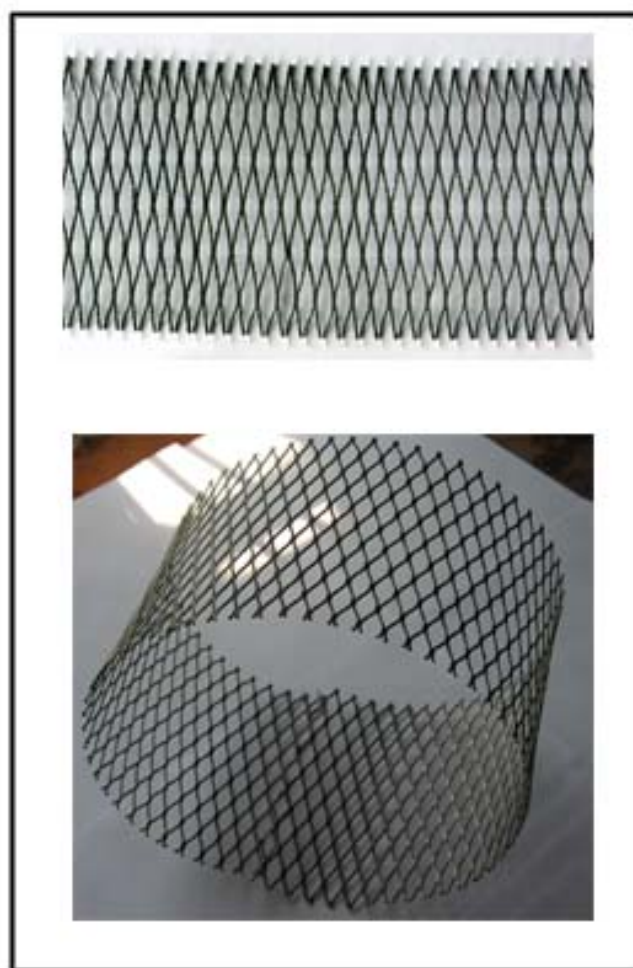

Fig.4 Net carrier of catalyst

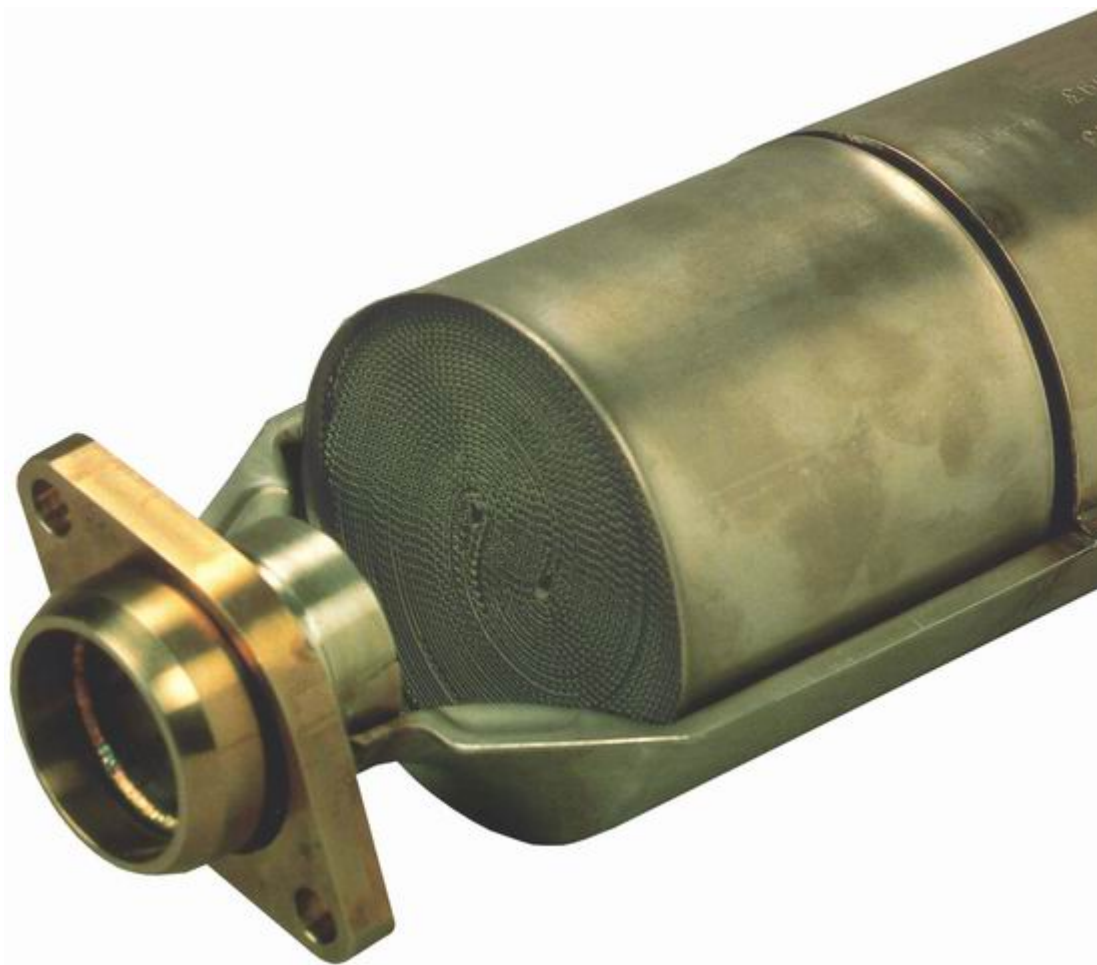

Fig.5 Gas generator with catalyst on a metal corrugated tape

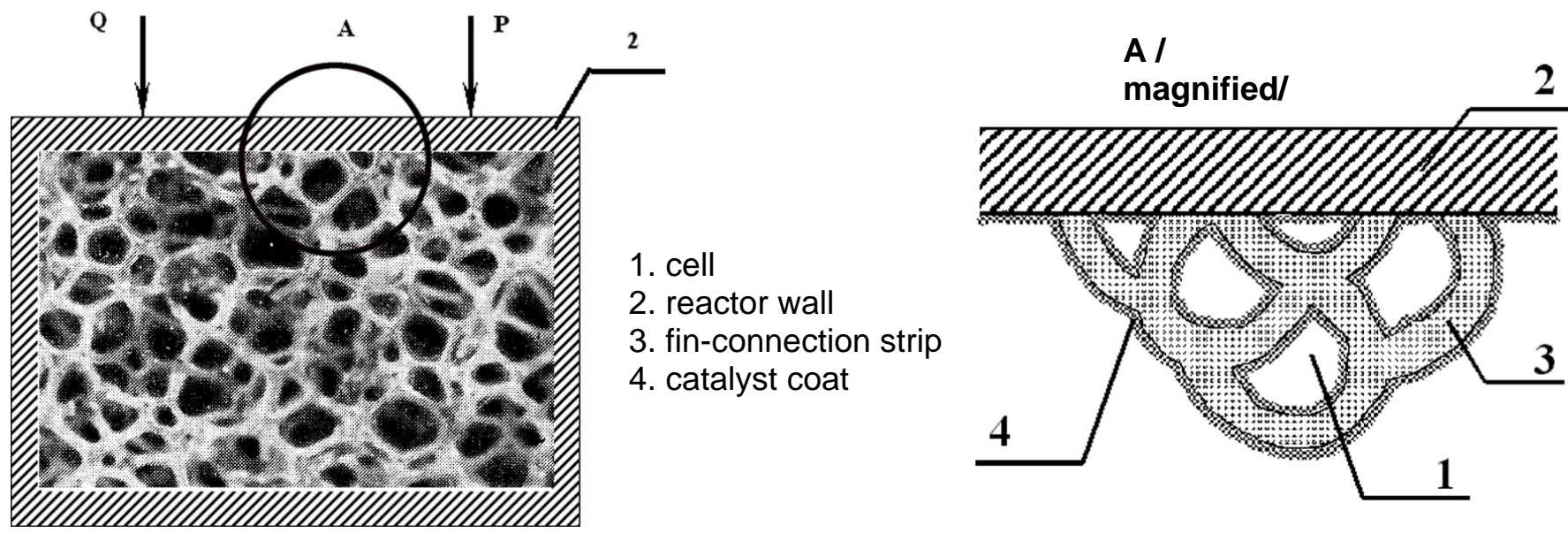

Fig.6 Fragment of catalytic reactor with volume framework catalyst on the basis of highly porous cellular material (metallic foam)

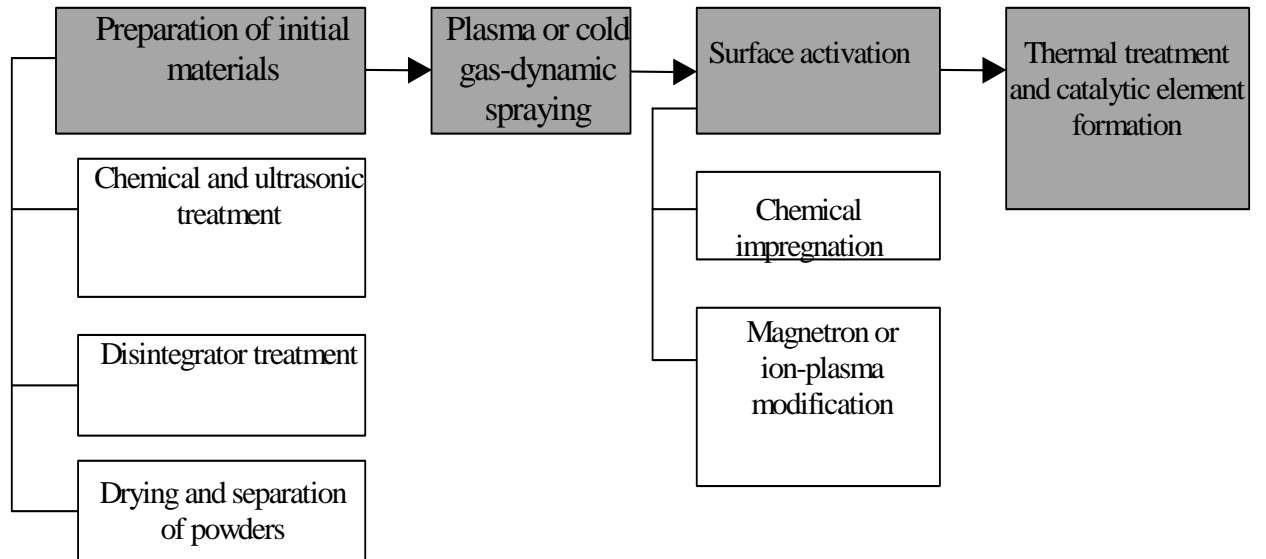

Fig.7 General technological procedure of catalytic material production

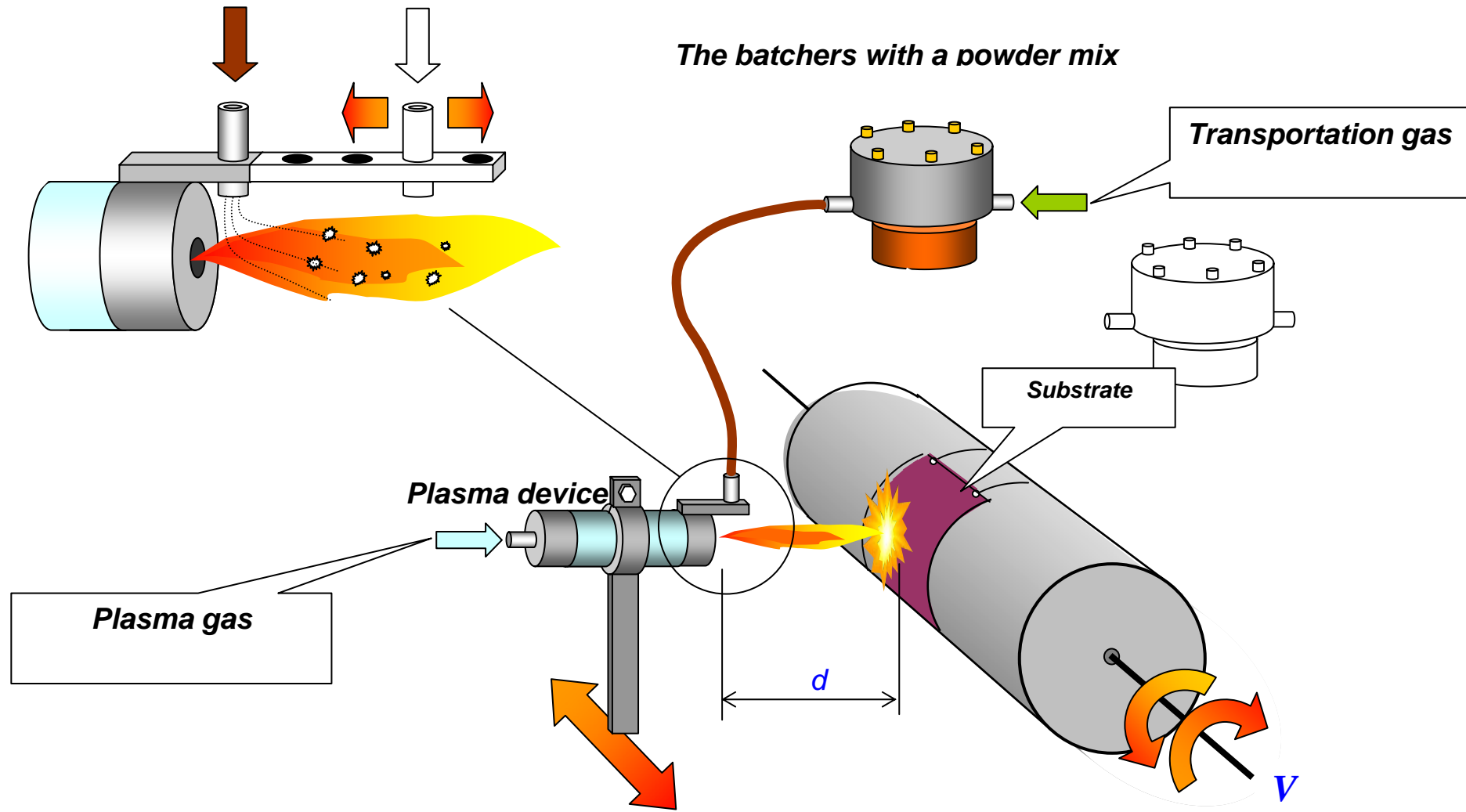

Fig.8 The schematic of plasma spraying process

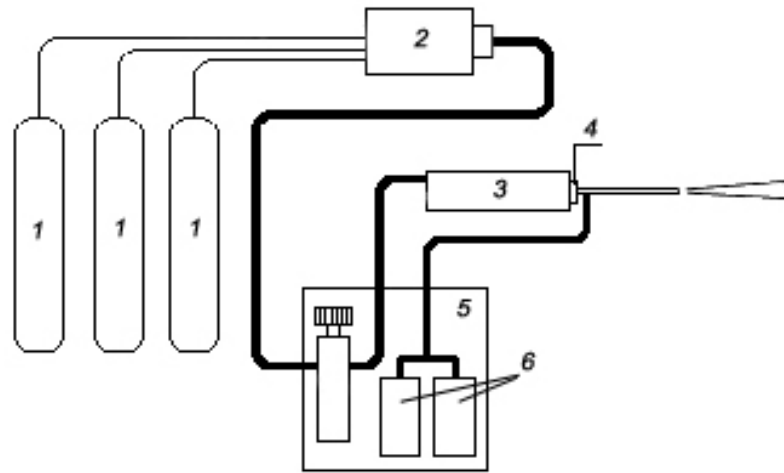

Fig .9 Schematic diagram and appearance of the installation for “cold” gas-dynamic spraying

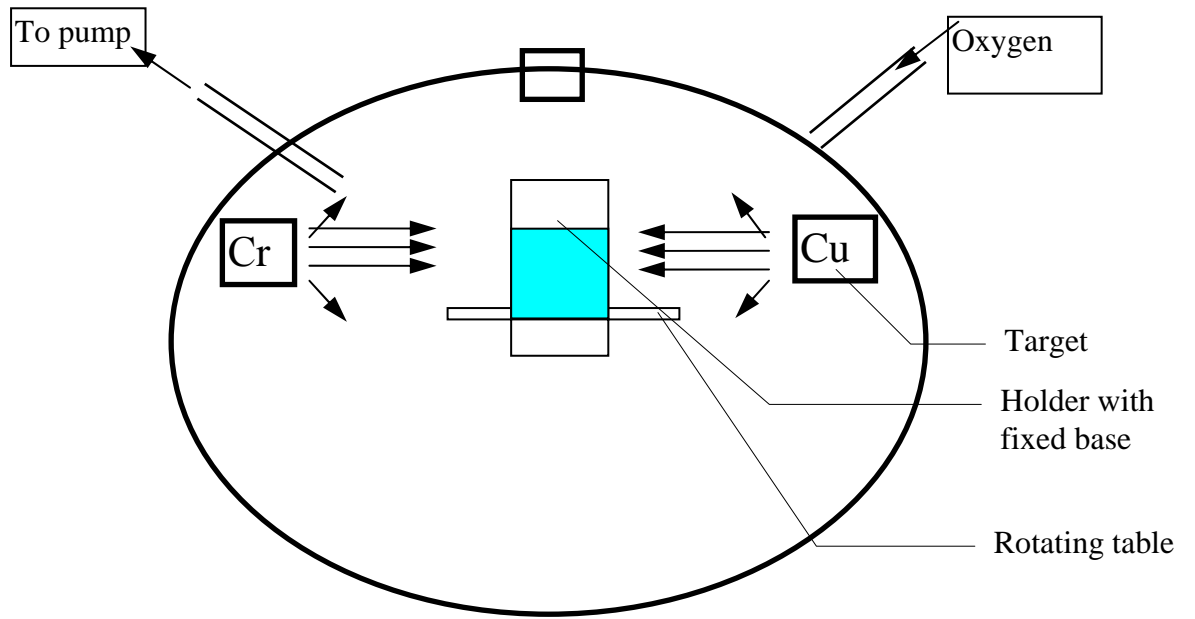

Fig.10 Targets layout on “Bulat-6” unit

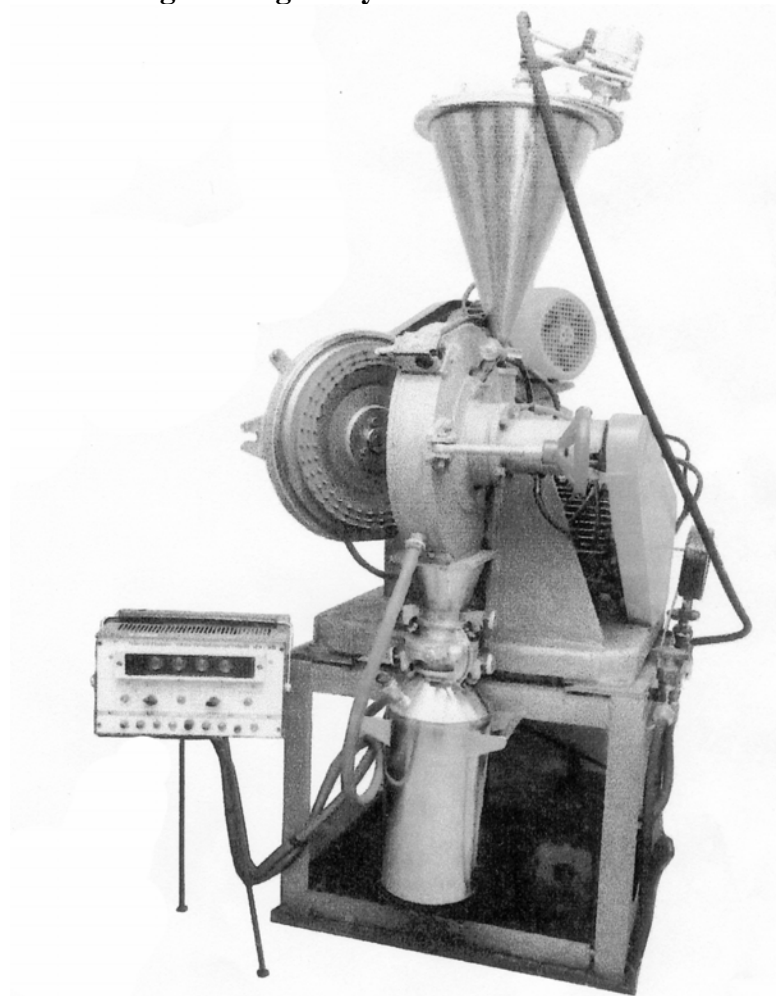

Fig.11 Impact-and-disintegration unit

5. SPECIAL FEATURES OF GAS-THERMAL APPLICATION OF CATALYTIC COATINGS

Gas-thermal spraying techniques are widely used for creation of protective coatings of multi-purpose designation. But the coatings used in the sphere of catalysis greatly differ from the protective ones in respect of their qualities. The coating properties depend on the technological parameters of the process making it possible to adjust them in a wide range. So, depending on a coating designation, properties of the spraying material, as well as the material of the base and shape of the item, technological mode in each particular case is selected experimentally being guided by general regulations of gas-thermal application of coatings and the results of R&D in the field of specified coating application. Basic technological scheme of fabrication and investigation of catalytic coating properties is presented in Fig.12.

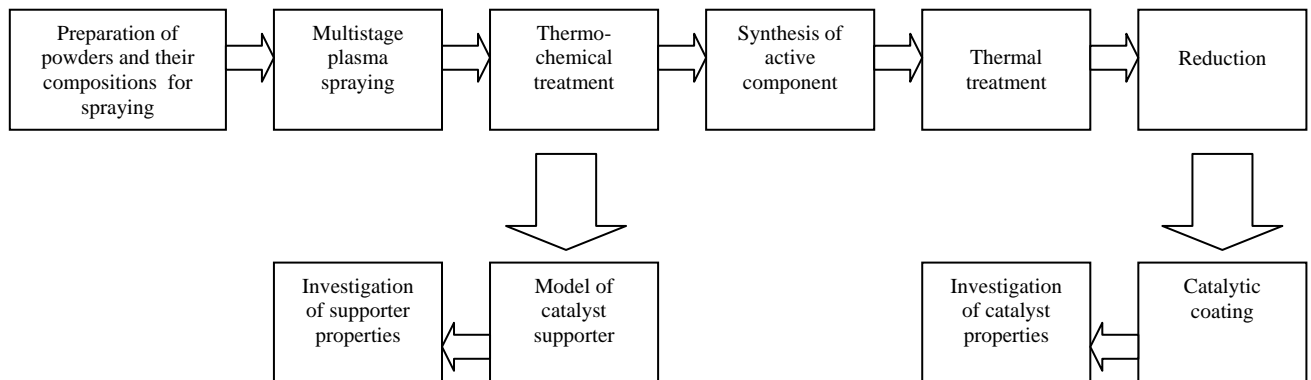

Fig.12 Basic technological scheme of catalytic coat production and investigation of its properties

The essence of gas-thermal application of coatings lies in the formation of the directed flow of dispersed particles of spraying material that ensures their transfer onto the surface of a work-piece at the optimal temperature and velocity values. Further on we shall consider one of the processes of gas-thermal spraying, namely arc-plasma one which is most frequently called plasma spraying. Schematic diagram of this process is shown in Fig.13.

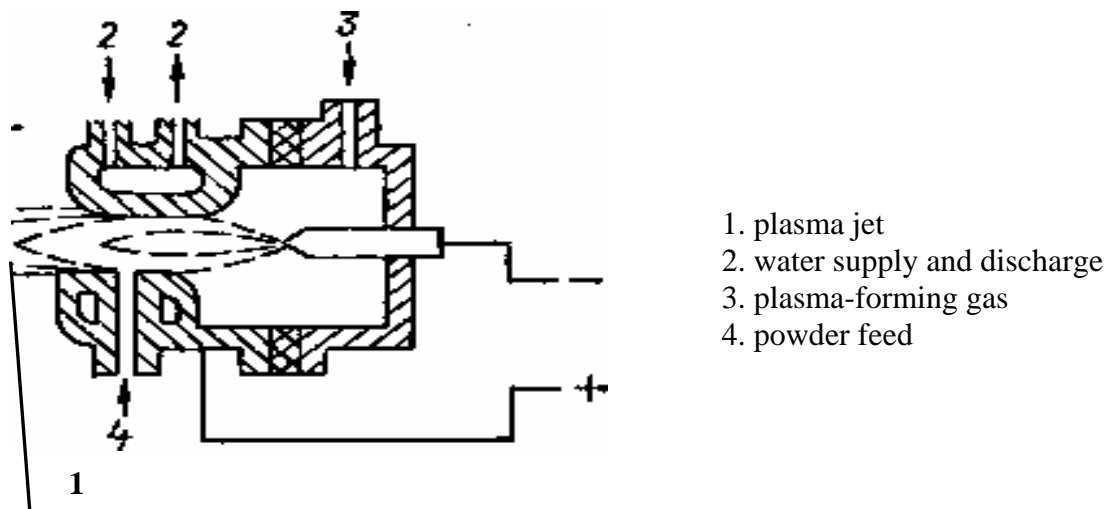

Fig.13 Schematic diagram of arc-plasma (jet) application of powder coating

At plasma jet application of powder coating, the melting of initial material takes place in plasma jet the temperature of which can vary in 5 000 – 50 000 K range. Arc-plasma jet is obtained by plasma-forming gas injection in the electric arc between two electrodes. Nitrogen, helium, air and other gases are used as plasma-forming ones. The particles of the initial powder when in plasma jet, melt and are transported onto the work-piece surface. Using plasma, it is possible to apply coatings of practically all refractory materials. Gas-thermal spraying of powder materials is a complicated process and its running depends on many factors. The most important of them are the following:

1. factors, associated with heating source of depositing materials (type of power source, its characteristics, power consumption, composition and rate of working fluid, etc.);
2. factors, characterizing depositing material (powder composition, its physical-chemical properties, granulation, shape, looseness, etc.);
3. factors, associated with the depositing material feed into high-temperature fluid jet (type of powder feeder, its characteristics, methods and point of powder feed into the jet, angle of input, etc.);
4. factors, identifying the spraying process itself (distance, relative transport rate of plasmatron and substrate, temperature of substrate, medium of spraying process, slope of jet in relation to substrate, current, voltage, temperature of fluid jet, etc.);
5. factors, associated with a sprayed-on work-piece (type of the material it was made of and its configuration, method of surface preparation for spraying, degree of roughness, chemical composition, availability of substrate, accessories used, etc.).

Diversity, as well as interaction of factors, hamper development of the technology of gas-thermal spraying for getting coats with preset properties. Therefore, experimental research should cover a wide range of problems, varying different process parameters and identifying empirical causalities.

The idea of plasma spraying of the supporter for hydrocarbon conversion lies in that powders of aluminum and of its hydroxide are transferred on metallic heat-resistant belt by the high-temperature plasma jet. Aluminum is deposited on the metallic base together with aluminum hydroxide in order to provide for required coating adhesion to substrate and is kind of “framework” for aluminum hydroxide.

Iron-chromium-aluminum alloys used as a base for deposition of powder materials on them are highly heat-resistant under the temperatures exceeding 1 000° C. The alloys are monophase and have a pure ferrite structure. They possess long-duration operability under heating conditions. The experiments have shown good adhesion between the alloy of X15IO5 grade and the coating sprayed on it, as well as a very high resistance of the sprayed-on belt to thermal fatigue. At the same time, Al hydroxides featuring considerable content of crystal water in the structure are rather unstable compounds and start decomposing under heating at not too high temperatures (see Fig.14).

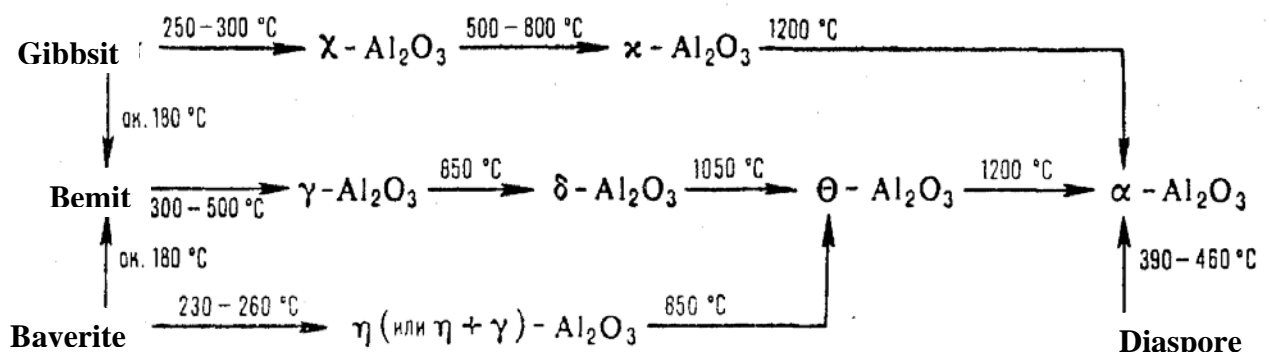

Fig.14 Quasi-static diagram of Al hydroxides transformation

Gibbsite $\text{Al}(\text{OH})_3$ is a hydroxide base most frequently used in the process of spraying. Under temperature impact gibbsite dehydrates, undergoing transition to bemite AlOOH and then, mainly, to alumina of gamma modification. It is consecutive decomposition of Al hydroxides that provides for developed surface. Further surface developing is obtained by after-decomposition of Al hydroxides remaining intact in the coat following spraying at the optimal temperature of annealing that takes place after plasma spraying of powders on metallic substrate.

In this particular case, during gibbsite particles passage through $6\ 000^\circ\text{C} - 8\ 000^\circ\text{C}$ plasma jet, it is necessary to prevent their complete decomposition. On the other hand, the particles supplied to the carrier gas stream should be melted in order to provide for the high cohesive strength with metallic belt carrier.

To deliver residual quantity of Al hydroxide (presented by gibbsite and bemite) to the metallic carrier in the process of plasma spraying – that was the main provision for gaining technical result.

To extend the surface, the coatings applied are subjected to the two-stage thermal treatment in the $350 - 700^\circ\text{C}$ range where decomposition of residual Al hydroxide takes place alongside with aluminum oxidation to $\gamma\text{-Al}_2\text{O}_3$ and formation of porous structure:

The 1st stage corresponds to $350 - 400^\circ\text{C}$ range and 0,5 h time delay. The first two water moles are released then and residual hydroxide (gibbsite) quickly goes over into fine-dispersed phase which is actual mixture of alumina and bemite.

The 2nd stage corresponds to $550 - 700^\circ\text{C}$ range and 1,5-2 h time delay. Bemite loses one more water mole and turns into aluminum gamma oxide ($\gamma\text{-Al}_2\text{O}_3$), required for getting porous coating.

Thermal treatment duration corresponds to the deepest gibbsite decomposition. Otherwise intermediate phases appear which make for the formation of alpha alumina which is characterized by low coating porosity in contradistinction to the gamma-phase.

Two factors promote the process of Al hydroxide oxidation and gamma alumina production: formation of centers of gamma alumina crystallization and punctual maintenance of heating temperature and time delay. It results in a more complete quantitative formation of gamma alumina required for provision of high catalytic activity of the sprayed-on coating.

For application of coatings on the base of $\gamma\text{-Al}_2\text{O}_3$, the low-temperature plasma and “slit” plasmatoms are used designed for plasma jet spraying of oxide and other powder materials with particle’s size not exceeding $100\ \mu\text{m}$ and allowing the usage of oxidizing plasma-forming gases. The low-temperature plasma is formed at atmospheric pressure and represents high-heated gas with relatively low degree of ionization. Its great merits is good transportation properties, i.e. the ability to transfer temperature and speed to the spraying-on particles. Given the most general requirements to the plasma-forming gases, namely high values of heat exchange criteria, inertia to the elements of plasma sprayer, low cost and non-deficiency, air was used in the capacity of the working (plasma-forming) gas. Air application in the spraying process provides for greater uniformity of temperature distribution along the cross-section of plasma jet.

The process of plasma spraying is the multi-factor one and the end result is determined by the composition and structure of the starting material, the equipment design and the process technological features (Fig.15).

Sprayed-on material consisting of aluminum and gibbsite powders was supplied jointly from the same batcher onto the plasmatron exit section in the remote areas of plasma jet. Optimal distance from the nozzle exit section of plasmatron to the base surface usually does not exceed $50 - 200\ \text{mm}$. Small spraying distances not always provide for heating of powder particles and ensure their sufficient speed. Besides, there exists danger of overheating the sprayed-on surface. Such situation is fraught with possible distortion of the base metal under the thermal stress. With distance increase on the basic portion of the jet the sharp drop of its temperature and velocity can be observed. Accordingly, the temperature and velocity of the sprayed-on particles also reduce leading to the formation of porous coating and reduction of adhesiveness with the base. The longest spraying distances are selected when running the process with laminar plasma or in a low

vacuum. In the end, peeling of the coat from the base can occur. The temperature of sprayed-on particles more often than not is equal to melting point or exceeds it considerably. Temperature increase stipulates for high contact temperatures on the spraying surface. It leads to the establishment of solid adhesion and cohesion bonds. Overheating of the surface results in decrease of the coat cohesive strength or causes deformation. Theoretical temperature of the base surface does not exceed 300° C. At the lower temperature the sprayed-on coat can get peeled or cracked. To achieve the uniform thickness coat, the thickness of the layer sprayed-on in a single pass should not exceed 25 µm. The specified thickness coating is sprayed in a single or several passes.

When spraying a coat, shrinkage of the evaporated layer occurs on the base surface. In case of the coating considerable thickness, under impact of residual stresses caused by the above shrinkage destruction of the contact area takes place followed by the coat separation from the base. Therefore, coating thickness should not exceed 50 – 70 µm.

Of great importance when selecting optimal spraying conditions is index of plasma-forming gas consumption. At its increase over optimal values, coating density significantly decreases. With gas consumption increase, spraying capacity of plasma jet, its velocity, and accordingly velocity of sprayed-on particles also increase. Heating temperature of the powders drops (while arc power remains invariable). On the whole, efficiency of the process is rather high. Volumetric consumption of plasma-forming gas under plasma jet spraying makes 2.0 – 4.0 m³/h.

Thus, selection of the optimal conditions for catalytic coat spraying has boiled down to optimization of separate technological parameters providing for the spraying mode sufficient for melting of aluminum particles and their speedy transfer ensuring safe adhesion between coating and substrate.

At determination of working spraying conditions in order to obtain catalytically active materials it is necessary, first of all, to ensure maximum deposition velocity and minimum heat flux onto substrate. Deposition velocity is in proportion to pressure of the spraying gas.

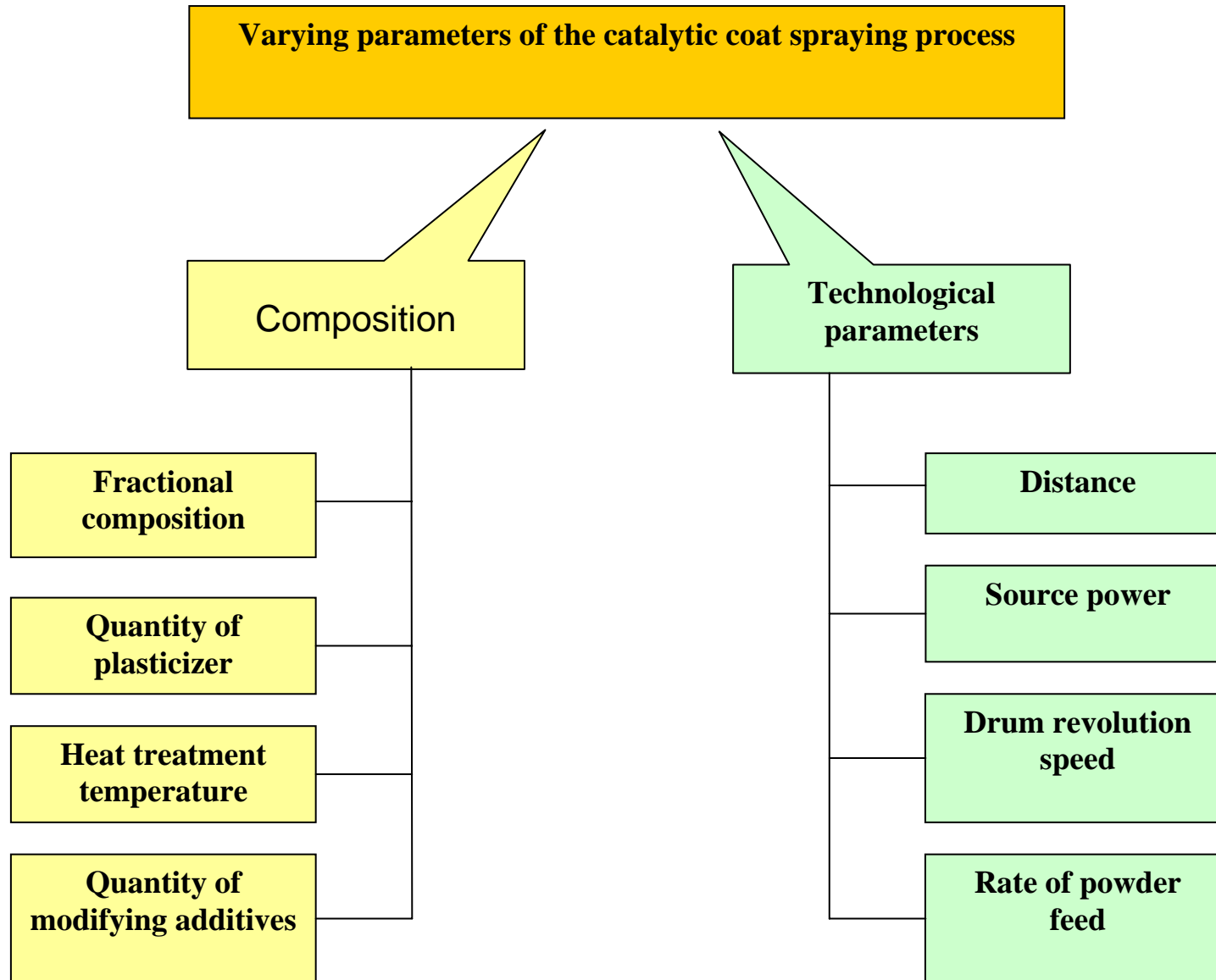

Fig.15 Factor multiplicity of plasma jet spraying process

Provision of the above requirements would allow to preserve amorphous structure of the initial state and high adhesion of the sprayed-on material to substrate. In the course of high-velocity plasma spraying, a number of problems of technical and technological character arise which, in turn, influence structure and properties of the coatings obtained.

In this paper, investigation and development of the technology of plasma jet spraying on the non-equilibrium structure have been conducted on the unit shown in Fig. 8. When analyzing influence of plasma spraying parameters as applied to the alloys with non-equilibrium structure, it was established that the following properties have the most significant impact upon this process:

1. Temperature of the spot on substrate
2. Distance from plasmatron section to substrate
3. Angle of attack of the protective jet

5.1 PHYSICAL PROPERTIES OF THE PLASMA SPRAYING PROCESS

The sprayed-on material is formed by gradual deposition of separate discretely solidifying with great velocity particles on each other in the coatings followed by successive coat-by-coat formation of the whole material. The sprayed-on material is usually formed by the particles of 10 – 150 μm size (in some cases 1 – 2 μm) that can have different temperatures and velocities and be in various aggregative states. Therefore this material is characterized by high degree of non-uniformity, laminated nature and high open porosity that is stipulated, apart from discrete mass transfer, by the process specific character featuring rapidly running high temperature (5 000 – 15 000 K) treatment of the material particles and their subsequent high-velocity (100 – 300 m/s) collision with the base surface. Sometimes considerable changes with chemical composition of the material take place due to the interaction of particles with the gases of surrounding atmosphere and plasma, as well as their thermal treatment during heating. Crystalline structure of the particles making a coating is defined both by phenomena occurring in plasma at their heating and acceleration and the processes of interaction with the base surface (impact, dispersion, solidifying, etc.)

Elementary individual interaction act at spraying, e.i, the interaction of a single particle of the disperse phase with the base, can be divided into three stages below:

- establishment of the physical contact;
- establishment of the chemical bonds as a result of activation;
- volumetric interaction accompanied by heterodiffusion, formation of the new phases.

Collision of the sprayed particle of the disperse phase with the solid surface of the forming material or the base causes its considerable deformation. The processes of impact and particle deformation occur simultaneously with their solidification. The nature of this process running , as well as its results, depend on temperature, velocity, aggregative state of the particle before collision and also on the conditions of the material surface the particle collides with. Analysis of spatial and temporal structure of the development of thermal and dynamic processes accompanying the impact, dispersion and crystallization of the particles shows that even at the maximum rate of spraying the probability for the melted particle to land on a not-yet crystallized one is very insignificant. Therefore, the coatings are formed of individually solidified particles leading, in the ideal case of spraying, to the appearance of a typical scale structure.

The sprayed-on material, as a rule, is formed by the repeated passages of plasmatron over a point or area of the surface. Under the linear plasmatron motion, there remains a “pathway” or roller of the sprayed-on material. To produce a coating on a surface, some transverse motion is also stipulated for plasmatron so that deposition of neighboring rollers takes place ensuring formation of the coating that covers the whole surface.

Within the period of plasmatron passages and deposition of coats, some deactivation of the sprayed-on material occurs; besides, its surface fouling or oxidization is likely to happen. As a result of it and due to difference in spraying temperature conditions, the boundaries of separation between layers obtained in a single plasmatron passage appear in the coating alongside with boundaries between particles and between the sprayed-on layer and the base. Thus, for the plasma spraying material to be formed, availability of three boundary types and relative elements is typical, namely: the base, the layer sprayed-on in a single pass, and a particle.

One more important feature of the material formation at plasma jet spraying is high velocity of solidification of the material particles. When filling a layer with the particles melted and overheated in a plasma jet, their solidification takes 10^{-10} sec that can result in a fine-crystalline state of the substance, fixation of metastable structures, amorphism, oversaturated solutions.

Multiple interaction acts of the individual particles of disperse phase with the base during formation of the physical contact area are indissolubly connected with the distortion of the surface layers of the base material. Of great importance are also the processes that take place in the contact area of separate particles and the whole sprayed-on material with the base. Apart from the aforementioned physical and mechanical interactions, the thermal and chemical processes also belong here.

The temperature that sets in at the contact area under particles interaction with the surface of a solid body, as well as the particle velocity, is one of the principal factors activating physical and chemical processes in the inter-phase area.

In the general formulation of the problem, it is necessary to reveal heat quantities supplied to the base by the gas flow, heat transfer from the high temperature particles of the disperse phase caused by transformation of kinetic energy of particles to the thermal one and also due to the reactions of inter-phase interaction of the base materials, disperse phase and gas medium.

The degree of non-uniformity in the structure of the coat formed in a single pass, is determined by the difference of energy (temperature, velocity) and aggregative states of the particles in the various areas of the two-phase flow of particles and heated gas. Formation of the coat by its successive filling with multitude of the forming particles with different temperature, velocity, mass, aggregative state inevitably leads to the appearance of microcavities and pores.

At plasma spraying, there is a possibility of two main types of sprayed-on coating structure formation depending on thermal-kinetic energy relation of the spraying particles at the moment of meeting with the substrate. The first type includes coats of granular structure. They can be obtained when kinetic and thermal energies are not sufficient for deformation of particles.

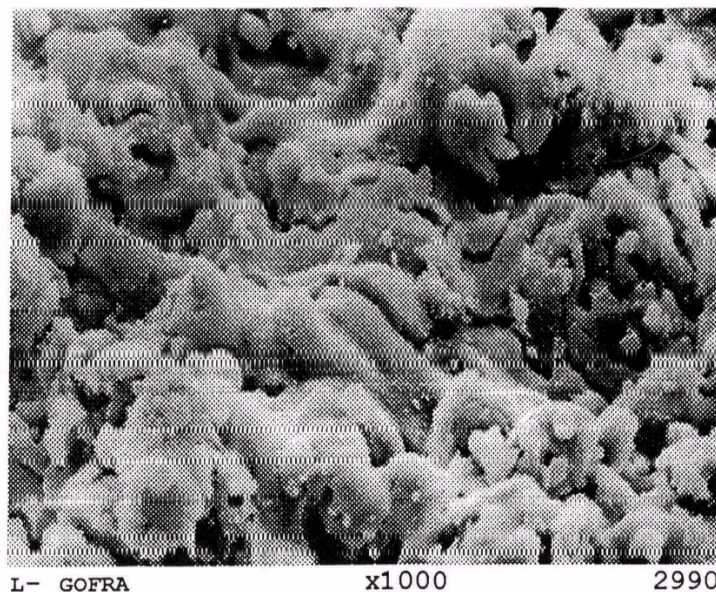

Fig.16 Outward appearance of the film structure of γ - Al_2O_3 system catalytic coating with extended surface (scaled up by 1000 times)

The structures of the second type are laminated ones. They are formed, as has been stated earlier, of the melted particles with relatively high speed of motion at the instant of their impact with the substrate. But the most typical are laminated structures of the mixed type. Outward appearance of the structure of γ -Al₂O₃ system carrier is shown in Fig.16.

In the process of deposition by spraying, temperature measurements of plasma spot have been taken in two variants: without gas feed for cooling substrate and at the cooling gas blowing.

Cooling gas pressure was 0.05 MPa, jet's angle of attack - 60°. The distance from nozzle exit section of plasmatron to substrate has been successively fixed at 120mm, 100mm, 80mm. Dislocation of the plasma spot center was observed at that time by 10mm, 20mm respectively.

**A****B****C**

Fig.17 Visual image of temperature field under various conditions of plasma spraying

The center of plasma spot without protective gas blowing is located on the axis of plasma jet (Fig.17a); besides, temperature gradient across the section of plasma spot that appears during spraying process comes to light. When substrate blowing is applied, drift effect of plasma spot center in relation to plasma axis comes into play but then temperature gradient equalization takes place. Gradient removal and selection though local but gradient-free zone makes it possible to spray non-equilibrium materials in the non-uniform field and preserve structure in coating thickness. Reduction of distance from nozzle exit section of plasmatron to substrate intensifies this effect to certain limits (Fig.17b). Abrupt reduction of this distance results in undesirable effect, greater dislocation of plasma spot center and increase of temperature gradient on substrate (Fig.17c).

As a result of Fig.17 analysis, it can be concluded that the most rational spraying conditions is one when the distance from nozzle exit section to substrate is 100mm but in order to improve this process it is necessary to apply radial blower of plasma spot which would most efficiently equalize temperature gradient on substrate.

In the course of the experiment, investigation of temperature field of plasma has been conducted. The temperatures across plasma jet have been taken. Temperature gradient obtained is presented in Fig.18.

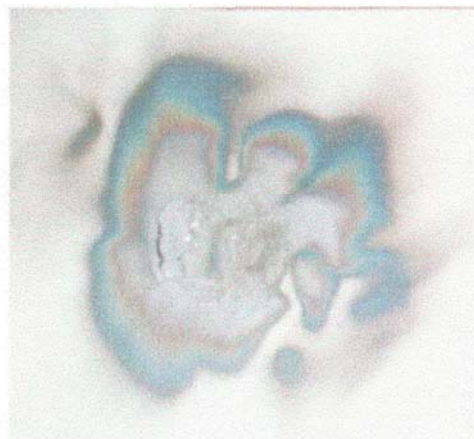
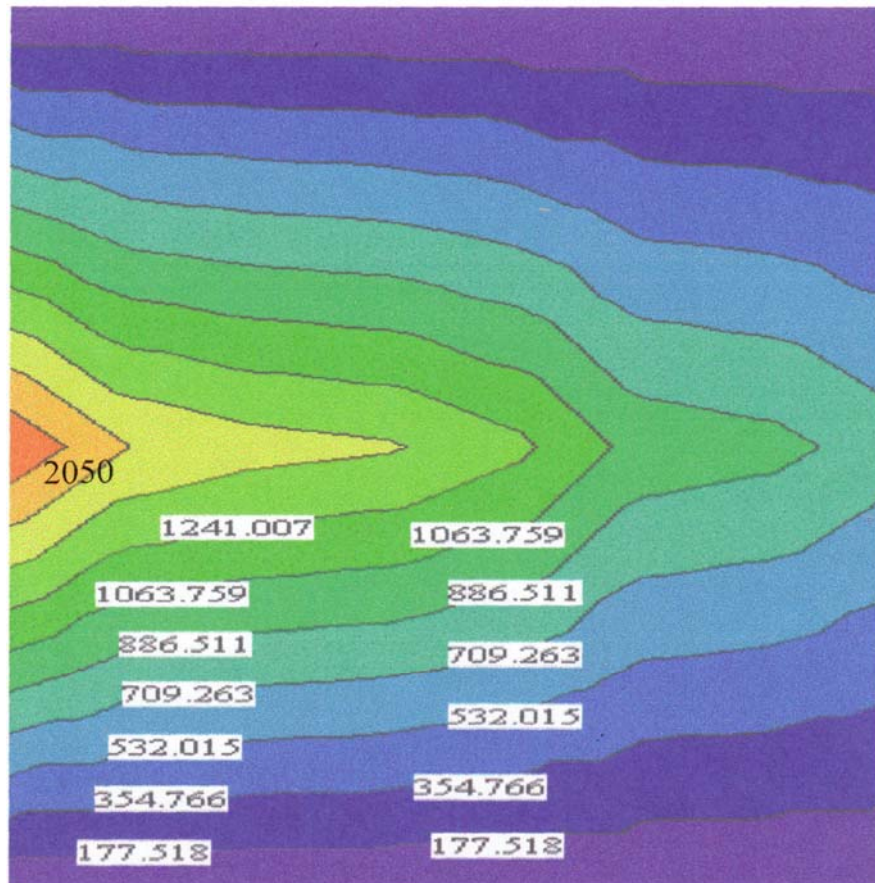
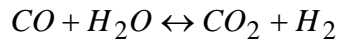
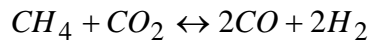
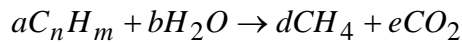

Fig. 18 Temperature gradient of plasma

In-depth study of qualitative characteristics of plasma jet temperature pattern allows, first of all, to choose with a great precision those temperature zones which are necessary for spraying non-equilibrium materials with the known temperatures of decomposition or structure degradation. Secondly, using jet temperature gradient, to apply functional and gradient coatings in steps, i.e., to spray inner adhesive coat at high temperatures ensuring maximum adhesion and peripheral coats – under the temperatures providing for preservation of structural phases and those of initial material. It is ensured by introduction of sprayed-on powder in the various areas of plasma jet.

6. CATALYST SUPPORTERS FOR THE 1ST STAGE OF HYDROCARBON STEAM REFORMING

First stage of steam reforming is a low-temperature ($t = 300-500^{\circ} \text{C}$) process of liquid hydrocarbon transformation as per below reactions



The first (irreversible) reaction ensures gasification of the liquid fuel and the other two determine composition of the gas obtained. The principal product of such a process is methane and its content can be as much as 78 %. Since this process runs at comparatively low temperature, certain requirements are made to the porous structure of the supporter. Porous structure is a collective notion. It includes a number of such characteristics as radius of pores, their volume and surface. Pores size effects velocity of diffusion of the basic reagents and reaction products and stipulates for access to a catalyst surface. Each concrete process is corresponded to by a certain optimal catalyst porous structure that depends on the conditions of process running and speed of reaction. The structure with a great volume of thin pores ensuring extended surface is expedient for slowly running reactions. Minimal diameter of pores must exceed total diameter sum of the molecules of the basic substances and reaction products in order to provide for their opposing traffic in capillaries. For the high-speed reactions, inhomogeneous pores structure turns out optimal one possessing, equally with short thin capillaries, long large pores acting as transport passages bringing up reacting substances to active centers. Diameter of the big pores has to be sufficiently large, so as to exclude pore-diffusion resistance while side capillaries should be of small sizes providing for the extended inner surface. Classification of porous structure was established as to its homogeneity and pore size.

Classification of porous structures by homogeneity: monodisperse, bidisperse and polydisperse porous bodies. Monodisperse structure is characterized by one maximum on differential curve of pore volume distribution in the effective radii while bidisperse structure – by two maxima.

Polydisperse porous bodies are characterized by diffused distribution. As to their size, the pores are divided into micropores with equivalent radius below 1.5 nm, mezopores with equivalent radius in the interval between 1.5 nm and 30 nm, macropores – with equivalent radius in the interval between 30 nm and 6500 nm. The total volume of the above pores is calculated from the difference of reverse values of the apparent ρ_{Hg} and real ρ_{He} densities:

$$V_{\Sigma} = \frac{1}{\rho_{Hg}} - \frac{1}{\rho_{He}}, [\text{cm}^3/\text{g}] \quad (1)$$

Index at density designation points out the substance with the help of which the appropriate value is determined. Total pore surface S [m^2/g] is determined from BET method by means of nitrogen heat absorption. Pore volume distribution on the equivalent radii is calculated from the data on mercuric porosimetry, while

$$r_{\text{эКВ}} = \frac{2\delta \cos \theta}{P}, \quad (2)$$

where δ - surface tension, θ - wetting angle, P – pressure.

Apart from the extended porous structure, supporter has to have good adhesion to backing, high thermo-and-vibration stability, as well as thermo-cyclic strength.

As a catalyst supporter, we have selected alumina (Al_2O_3) applied onto metallic backing. Usage of metallic backings such as, i.g., alloy of the grades X20H80, X18H10T or X15IO5 require thorough surface treatment and a special technology of coat application. To enhance catalytic coating homogeneity and proper adhesion, samples surface has been subjected to mechanical treatment from oxide films or chemical pickling. Mechanical treatment of the samples (50x12 mm plates) was performed in the ball mill under the following conditions:

Volume of metallic drum – 1.3 dm^3 , number of balls – 11, ball's mass – 3.3 g, quartz sand mass with $1.0 \div 1.3 - 200 \text{ g}$ dispersity, treatment time – $0.1 \div 1 \text{ h}$. It was discovered that with time increase of back treatment of steels X20H80 and X18H10T, specific surface has increased by nearly four times and reached $0.011 - 0.014 \text{ m}^2/\text{g}$ while the plates mass decreased by 5-6 %. Treatment of the plates made of the alloy X15IO5 in 0.5h resulted in the increase of both specific surface (by 10-12 times) and mass (\approx by 10 %). Such effect is evidently stipulated by intensive oxidation of aluminum which is a part of the alloy composition and by formation of the porous oxide, approximately $0.25 \text{ mole Al}_2\text{O}_3/\text{m}^2$. Analysis of after-treatment state of the samples surface by optical microscopy method proved formation of relief texture with typical cavities and peaks. Impact of parameters of chemical pickling (temperature $90 - 160^\circ\text{C}$, time – $0.01 - 1.0 \text{ h}$, alkali NaOH concentration – 10-30 % by mass) on surface variation has been studied on X15IO5 alloy. With increase of temperature and time of leaching specific surface increases, too (up to $0.22 - 0.63 \text{ m}^2/\text{g}$; variation of NaOH concentration did not practically influence surface extension.

Powder composition made mainly of hydroxide $\text{Al}(\text{OH})_3$ [90 %] with addition of aluminum powders and modifying admixtures has been plasma sprayed on the treated sample surface. The amount of aluminum and additives varied for different samples. The initial mixture was subjected to homogenization and activation on the disintegration unit in order to obtain powders of the desired dispersity and high technological activity. After disintegration treatment sieving followed. For plasma jet spraying powders of $40 - 63 \mu\text{m}$ size were used.

As it has been already mentioned, the idea of plasma spraying of the supporter for hydrocarbon conversion lies in that powders mixture is transferred on metallic heat-resistant belt by the high-temperature plasma jet. Aluminum hydroxide – gibbsite ($\text{Al}(\text{OH})_3$) – thereat under the temperature impact dehydrates and passes into bemit (AlOOH) and then – in the oxide Al_2O_3 .

Consecutive decomposition of aluminum hydroxides ensures extended surface. Aluminum is deposited on the metallic base together with aluminum hydroxide in order to provide for required coating adhesion to substrate and acts as sort of “framework” for aluminum hydroxide.

Lanthanoid-type admixture designation – thermal stabilization of the supporter surface.

A number of experiments conducted over extended period of time made it possible to develop technology ensuring required parameters of catalytic process. The specific features of the plasma jet spraying technology have been described in the previous report.

Plasma spraying of catalytic supporter on metallic belt was performed on the “Plasma-1” installation, designed and developed just for realization of this technological process with the usage of air plasmatron and measuring hoppers of original design. To increase mechanical strength of coating, plasma spraying consisted of two stages: deposition of the first adhesive sub-layer providing for adhesion with catalyst carrier on the basis of powder composition Ni-Al and deposition of the second porous layer of the system Al-Ni-Al ($\text{OH})_3$ – modifying admixtures. The adhesive sub-layer was $10-15 \mu\text{m}$ thick with low specific surface and high content of metal binder (not less than 5 %) The results of plasma spraying process optimization are shown in Table8.

Table 8**Optimal modes of plasma spraying**

№	Parameters of spraying process					
	Voltage, V	Current, A	Pressure of plasma-forming gas, arb.unit	Pressure of focusing gas, arbitrary unit	Drum rotation speed, rps	Distance to base, mm
1	250	155	90	60	14	70
2	250	180	90	100	12	70
3	240	180	92	100	12	70

Investigations aimed at determination of chemical and phase composition of the sprayed-on coating have been carried out by roentgeno-structural method on the "Dron-3" installation.

The investigation results for optimal modes are presented in Table 9.

Table 9**Basic parameters of catalytic coating after spraying**

No	Parameters of the sprayed-on coating				
	Phase composition of coating, %				Coat thickness, μm
	Aluminum hydroxide	Aluminum	$\gamma\text{-Al}_2\text{O}_3$	$\alpha\text{-Al}_2\text{O}_3$	
1	85-90	3-8	3-5	1-2	55-60
2	88-93	3-6	1-3	менее 1	45-50
3	88-93	3-6	1-3	менее 1	55-60

As a result of spraying as per developed conditions we have obtained a wide spectrum of various hydroxide phases (gibbsite and bemite), oxide (γ and α - phases, as well as practically all intermediate phases of aluminum oxide modification - η , θ , ξ , etc. but in small amounts) and aluminium.

The above alumina modifications are usually characterized by spinel structure and differ from each other by defects in crystal lattice

Aluminium oxide of α modification-corundum is its most stable form to come across in nature. Its heat of formation makes 400 kcal/mole. It does not undergo any transformations during heating up to the melting point (above 2000° C). Porosity of $\alpha\text{-Al}_2\text{O}_3$ fluctuates from 5 to 20 % and its specific surface can reach 10 m²/g. $\gamma\text{-Al}_2\text{O}_3$ has heat of formation equal to 380 kcal/mole. As to its strength, it is inferior to corundum but surpasses it in porosity with specific surface up to 150 m²/g. There is a chain of transformations such as follows:

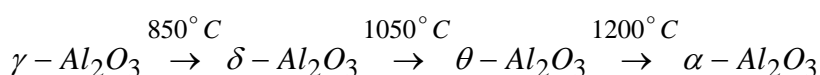

The next technological stage of coating application on catalyst supporter is thermal treatment of the samples. Its main purpose is decomposition of the sprayed-on aluminum hydroxides (gibbsite and bemite) up to $\gamma\text{-Al}_2\text{O}_3$ and steam, Al oxidation, sharp increase of the sprayed-on layer adhesion to metallic supporter at the expense of diffusion processes running and lastly formation of porous structure.

Decomposition kinetics investigation pointed out that it proceeds in several stages. The first stage corresponds to the temperature range 350 – 500° C and triggers partial decomposition of gibbsite and its transition to bemite. At the second stage (550 - 650° C) direct decomposition of gibbsite into $\gamma\text{-Al}_2\text{O}_3$ and steam takes place. At $t > 900^\circ\text{C}$, $\gamma\text{-Al}_2\text{O}_3$ transforms into $\alpha\text{-Al}_2\text{O}_3$ that leads to degradation of supporter surface quantity. It seems only sensible to optimize the modes of supporter thermal treatment from the phase composition and specific surface quantity. The results of investigations carried out while selecting modes of thermal treatment of the samples in the air are presented in Table 10. It can be seen from this table that the optimal mode of the thermal treatment is annealing in the temperature interval 550 – 650° C which ensures the

structure with practically homogeneous, as to the phase composition, structure ($\gamma\text{-Al}_2\text{O}_3$) with the maximal free surface.

Table 10**Basic parameters of catalytic supporter depending on thermal treatment mode**

Annealing temperature, °C	Phase composition of coating, %	Magnitude of free surface, m ² /g
350-500	Gibbsite > 80 %, bemite: 3-6 %, γ -alumina < 5 %, α -alumina < 3 %, aluminium < 5 %	5-10
550-650	Gibbsite < 1 %, bemite: 1-3 %, γ -alumina > 80 %, α -alumina: 3-5 %, aluminium < 1 %	50-80
650-850	Gibbsite < 1 %, bemite < 1 %, γ -alumina < 80 %, α -alumina 5-8 %, aluminium – absent.	40-20

6.1. INVESTIGATION OF SUPPORTER SURFACE PROPERTIES

a) Determination of true density using helium (He)

True density ρ_{He} is the mass of substance, skeleton of a porous body consists of, in the volume unit of this substance. The method lies in finding helium volume displaced by a certain mass of the porous body. Schematic of the installation for determination of the true density with helium application is presented in Fig.19.

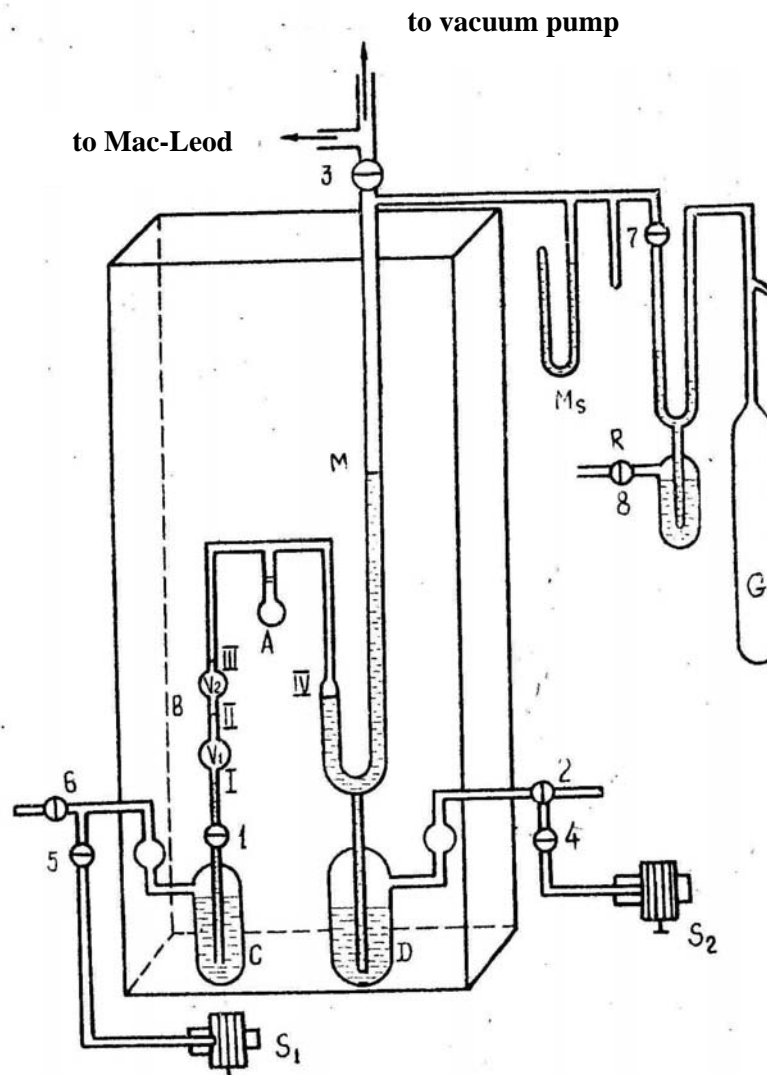

Fig.19 Installation for determination of true density with helium application

True density is determined from formula below:

$$\rho_{He} = \frac{m}{V_o - V_x},$$

where m – mass of the sample; V_o – volume of measuring system between levels III and IV without supporter's sample, cm^3 ; V_x – volume of measuring system between the same levels with the sample of the supporter under investigation.

b) Determination of apparent density by pycnometric

Apparent density ρ_{Hg} is the mass of substance of a porous body in the volume unit filled up by supporter's particles. The method lies in determination of mercury volume displaced from pycnometer when the sample under investigation is being put in it. The sample's mass is known. Schematic of the installation for determination of the apparent density is presented in Fig.20.

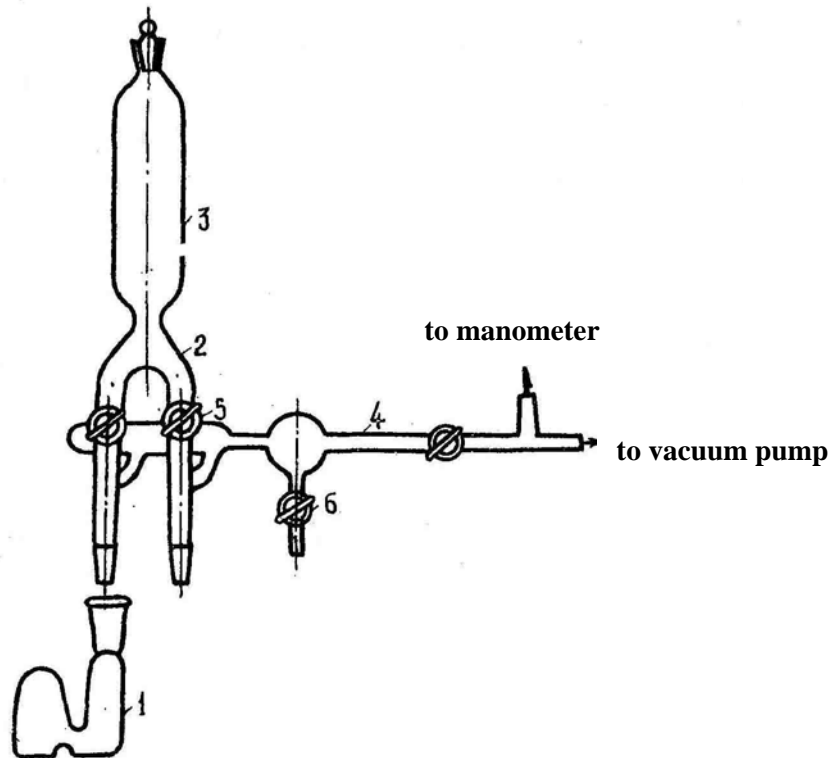

Fig.20 Installation for determination of apparent density by pycnometric method
1 – pycnometer; 2 – pack with a vessel for mercury 3; 4 – vacuum line; 5,6 – cocks.

Apparent density is determined from formula below:

$$\rho_{Hg} = \frac{m_2 - m_1}{(m_2 - m_1) - (m_4 - m_3)} \cdot d_{Hg},$$

Where m_1 –pycnometer's mass; m_2 –mass of pycnometer with sample; m_3 – mass of pycnometer with mercury; m_4 –mass of pycnometer with sample and mercury; d_{Hg} –mercury's specific gravity at thermostating temperature. From true and apparent density values total volume of pores V_{Σ} is calculated as per formula (1). At gibbsite thermal decomposition it proved to be equal to 0.2 – 1.4 cm^3/g for different samples.

c) Determination of supporter's samples specific surface

As previously stated, specific surface of the samples presented in Table 3 has been determined from nitrogen thermal desorption. The method lies in determination of gas volume, first pre-adsorbed on the surface of investigated sample from the gas mixture flow at the temperature of liquid nitrogen, and then desorbed from it at temperature increase with further

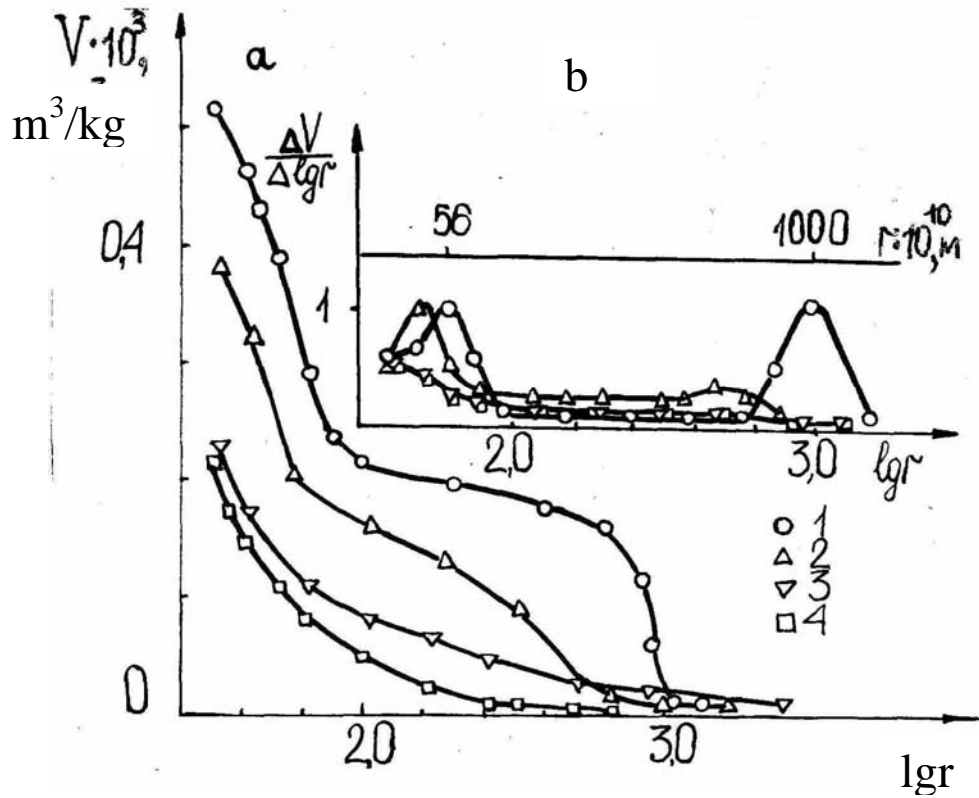

Fig.22 Integral (a) and differential (b) curves of pore volume distribution in radii

The curves 1 and 2 relate to bidisperse distribution while curves 3 and 4 – to polydisperse one. In Fig.23, electron microphotographs of alumina replicas mainly with small (A) and large transporting pores (B) are shown.

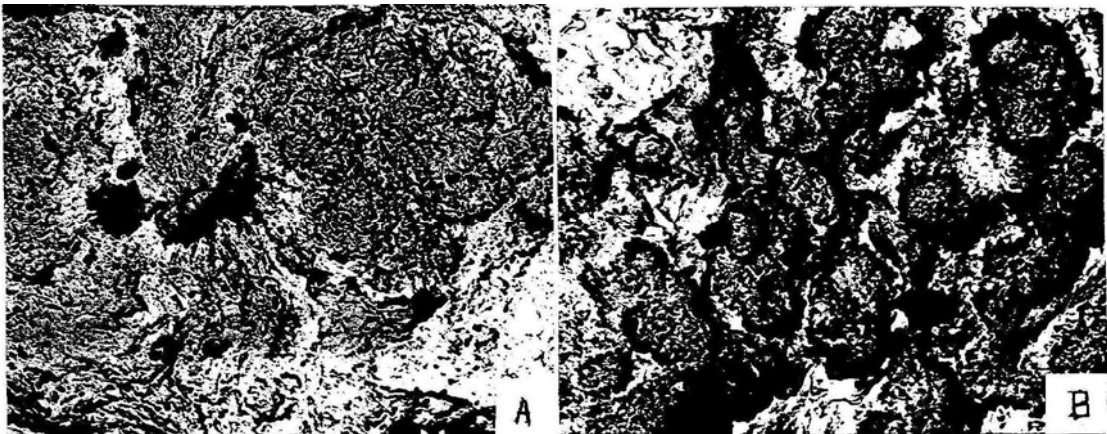

Fig.23 Electron microphotographs of alumina replicas

7. SPECIAL FEATURES OF EVAPORATIVE CONDENSATION PROCESSES

The most responsible element in the “material-working medium” system determining permissible operating conditions and durability of the whole system is the material’s surface. Particularly it holds true for catalytic coatings when applying them directly on the construction parts of various aggregates. The volume and surface of any workpiece should be always considered as one system. It has to be insensitive to the working conditions irrespective of the way governing creation of the coat – by surface modification of the workpiece itself or by application on the substrate of mono-or-multi-layer coating of some other material. Coating optimization presupposes an appropriate selection of a coat composition, its structure, porosity, adhesion and other factors. One must note inconsistency of requirements to the characteristics of the protective and catalytic coatings. First of all, it goes for their density and porosity. The protective corrosion-resistant coatings have to be dense, with porosity < 1 %. The catalytic coatings must have a great surface; their comparatively large open porosity (15-50 %) helps to meet this requirement. The latter leads to degradation of mechanical and corrosion-resistant properties of a coat but helps to resist coat peeling at thermocycling. Therefore, a trade-off has always to be sought between different coat properties, as well as experimental selection of technological ways of their application for each particular case.

Existing methods of traditional catalysts preparation, mostly granular ones, do not meet requirements to their usage in various power installations. That is why a search for new technologies of catalytic material creation never stops. Of a certain interest among them is modification of the existing technologies of ion-plasma and magnetron spraying of the thin films for production of catalytic material.

Technologies of evaporative condensation including ion-plasma and magnetron spraying, make it possible to obtain multifunctional and sometimes unique in their properties coatings on the basis of refractory metal compounds and their alloys (Al, Ni, Co, Ti, Cr, Mo and others).

The best known and promising methods of condensation are ones with ion bombardment (IBC) and magnetic ionic spraying (MIS). That is due to the versatility of these technologies, high efficiency of coat deposition processes and their ecological purity.

Essentially, the method of ion-plasma spraying is evaporation of a metal (or alloy) atoms from the target surface under the impact of plasma flow and their subsequent directed deposition on the supporter. The process of deposition of metal coatings takes place in a vacuum. To obtain coats on the basis of metal oxides, oxygen is introduced in the process of deposition. Spraying is carried out using the method of condensation of the material which is evaporated by electric arc in the vacuum with prior surface cleaning at the expense of ion bombardment (IBC method).

The method of ion-plasma spraying in arc discharge plasma is realized on the installations of Bulat type. When this method is used, plasma flow is generated as a result of erosion of cathodic material in cathode spots burning on the cooled cathode. Body of the spraying chamber serves as anode. The discharge is sustained in a static or dynamic vacuum. Degree of ionization of vapor flow can reach as high as 97 %, at kinetic energy of deposited ions making up to 200 eV. In the process high coat adhesion (up to 100 kg/mm²) and coat density (up to 95 %) are obtained.

The targets for ion-plasma spraying are truncated cones 45 mm high, with diameters of lower and upper bases of 60 and 55 mm respectively. The vacuum one-chamber installation of ion-plasma spraying is fitted with three pockets for the targets and leaks for the gases. Layout of targets in the working chamber of installation is shown in Fig.10. Still picture of the installation is presented in Fig.24. Provision is made there for operation with one, two or three cathodes. To obtain coatings containing oxides, carbides, nitrates of the spraying metal, the chamber is supplied with reaction gases – oxygen, nitrogen, acetylene and so on. The limiting residual pressure in the working chamber makes no less than 1×10^{-4} mm Hg. By changing the number of cathodes used and arc current in the range from 50 to 150A we can control film deposition rate over a wide range.

Magnetron deposition method is based on the usage of magnetic system of ionic spraying that is related to diode systems in which atoms of spraying metal are taken off the cathodic surface by ions of plasma-forming gas (Fig.25). In supply of constant voltage, a nonuniform electric field occurs between the target and anode and abnormal glow discharge is excited. The presence of permanent magnets under the target establishes arc magnetic field that increases many-fold over concentration of electrons and ions of plasma-forming gas in cathode-bonded space (Fig.26). It makes for more intensive knockout of cathode metal molecules and increase of current density. With this method there is no intensive bombardment of the substrate by high-energy electrons and it enables one to apply coatings onto soft-melting substrates. Simplified line diagram of the Mir installation and sequence diagram of magnetron spraying process are shown in Fig.27. Still picture of the installation is presented in Fig.28.

A special feature of our technology of evaporative condensation, including ion-plasma and magnetron spraying, is usage of:

- the cathode system allowing to achieve stoichiometric composition of a coat;
- focusing and deviation of heterophase flow system barring the formation of the drop phase.

Technological cycle of coating application consists of:

- pre-cleaning of the samples in ultrasonic bath at $T = 70^{\circ}\text{C}$ using washing solution. In the process of cleaning macroinclusions are removed from the surface;
- wiping the surface with acetone, rinsing out in cold and hot water, wiping with alcohol and drying in autoclave at $T = 80\text{-}100^{\circ}\text{C}$;
- positioning of samples in vacuum chamber and their treatment in a glow discharge dc for removal of the particles loosely bonded with the surface;
- ionic cleaning, i.e. simultaneous action on the surface by ions of gas and evaporating metal. In the process, sample heating occurs up to the required temperature;
- application of coating.

A serious problem of coating production by evaporative condensation method is non-stability of their structure and properties. It is associated with existence of numerous, hard-to-control parameters of the spraying process, inclusive of partial gas pressure in the chamber, current density, reference voltage, temperature of the substrate and the state of its surface.

Establishment of reliable correlations between the parameters of the spraying process, the macro-structure and working characteristics allows assignment of coating process parameters, and in so doing – enhancement of quality, coat reliability and potential to control their properties. Among technological parameters that determine coat properties are residual pressure in the vacuum chamber, chemical composition of residual gases, partial pressure of the reaction gas in the chamber, ionic current density, temperature of the substrate, quality of the surface pre-treatment and degree of its activation at ionic bombardment, film deposition rate and so on.

Let us consider how basic parameters of the process influence the properties of catalytic material to be obtained:

- With ion-plasma spraying, increase of arc current leads to decrease of coat microhardness, therefore it is expedient to maintain arc current at a minimal level capable of sustaining stable burning of the discharge.

Condensation rate also significantly influences coat microhardness. At high current densities high internal stresses appear, due to insufficient relaxation time, matched by considerable microhardness increase (up to 1800 kN/mm^2). But in the course of time that triggers the danger of spontaneous peeling of the coat. The effect of the distance from cathode to the support on coat microhardness is insignificant.

- The thickness of a coat to be obtained is a function of deposition time. To acquire desired thickness of $5 - 10\ \mu\text{m}$, condensation rate was taken on the level of $0.5 - 0.4\ \mu\text{m/min}$. It was found out that three technological parameters have a considerable effect on a coat thickness, namely: arc evaporator current, distance from cathode to support and deposition time.

- To attain good adhesion of a coat to a porous carrier when selecting deposition conditions consideration must be given to the following requirements:
 - coat thickness should make 5 – 10 μm ;
 - surface condition following deposition by spraying must not deteriorate;
 - in the process of spraying potential on the substrate has to ensure work-piece temperature at 350 – 450 ° C level.
- The method of ion-plasma deposition has the advantage that there is no temporal gap between completion of fine cleaning of the substrate surface in the glow discharge and the beginning of coat deposition because substrate is permanently at negative potential. Hand in hand with surface cleaning, a partial atomization of metal from the surface takes place, as well as its considerable activation with simultaneous condensation of atomized metal ions on the surface. By specifying optimal parameters of the technological process we ensure cleaning conditions under which the rates of micropollution removal and atomization of substrate material will be maximal and there will be no condensation of metal atoms on the substrate. Required combination of enumerated parameters ensures high coat adhesion with substrate and smooth transition to the coat deposition conditions.

Within the first stage of deposition process a film is formed from the material of evaporating cathode followed by smooth transition to the layer of metal oxides or their alloys. The suggested scheme provides, on the one part, for more efficient surface preparation and, on the other part, promotes formation of more qualitative coating at the expense of evaporating material.

- Degree of roughness of substrate surface is an important parameter pre-determining structure and functional characteristics of catalytic material. As a result of ionic bombardment of the surface a relief is formed caused by bulge and cavity etching process. Analysis of study results has shown that the nature of surface topography variation depends on the dose of ions interacting with substrate and on initial irregularity of the surface. With energy action of ionic flow upon polished surface, the process of its relief development can be observed caused by interaction in the “ion - solid” system. Roughness parameters are increased by several times as compared to initial ones. Further increase of ion bombardment duration leads to equalization of the growth rate of bulges and their atomization with roughness magnitude practically unchanged.

7.1 MANUFACTURE OF CATHODIC MATERIALS AND SPRAYING OF NI – AL SYSTEM

In line with our conception on creation of catalysts for fuel steam conversion and chemical heat regeneration, usage of aluminum and nickel should provide for carrier adhesion with substrate; deposition of aluminum hydroxide will allow to obtain highly porous surface and introduction of rare-earth elements (lanthanum, cerium, niobium) and transition metals (nickel and chrome oxides) will stabilize low-temperature aluminum oxides and ensure catalytic activity of the material.

In development of catalytically active materials for fuel steam conversion we suggest that method of evaporative condensation be used in the controlled gas media in order to obtain coatings with amorphous and microcrystalline structure which are highly active catalytically. And it was proved by the results of preliminary experiments. This method allows application of activators layer by layer 2 – 5 μm thick with subsequent diffusion on primary porous carrier, significantly increasing, as compared to carrier, catalytic activity of the material and preserving its high porosity.

To achieve this, it seems expedient to carry out spraying either using one combined target of several materials or targets made from separate metals (nickel, aluminum, etc.) depending on the task assignment. In this case it is possible to obtain a coating of specified composition due to the possibility of their separate control and, respectively, acquisition of coatings with different compositions.

To reach this objective, we have manufactured cathodes from nickel and aluminum and performed layer-by-layer application of coatings (using Bulat installation) on:

- Ni-Cr alloy of X15IO5 grade, 100 x 100 mm in size – for measurement of catalytic activity;
- Titanium foil – for determination of a coat chemical composition (titanium was used for more precise determination of nickel in a coat);
- Primary porous catalytic carrier on the basis of aluminum – aluminum hydroxide system.

The coatings were applied from two sides using both cathodes. After that the samples underwent two hour thermal treatment in a vacuum oven.

The study of amorphous and microcrystalline materials for establishment of technological regularities has been conducted by determination of chemical composition of catalytic materials using X-ray spectral microexamination on microanalyser “Camebax micro” equipped with “Link-860” spectrometer. Calculation of fractions of total mass of elements was carried out as per ZAF4 program. Chemical composition was determined at several randomly chosen areas of each sample of amorphous or microcrystalline alloy. The results are presented in the table 11 below:

Results of chemical analysis and conditions of coat application

Table 11

Sample No	Fraction of total mass, % (average composition)			Fraction of total mass, % (local composition of homogeneous regions)			Conditions of coat application				
	Al	Fe	Ni	Al	Fe	Ni	$J_{Ni,A}$	$U_{S,B}$	$J_{Al,A}$	$U_{S,B}$	τ, min
1	15,6	3,8	80,2	17,5	4,4	78,0	110	0,3	80	50	Ni-25 Al-10
				0,2	3,7	96,0					
				11,7	1,1	87,0					
				29,8	3,8	66,2					
				52,1	4,7	43,0					
2	15,2	3,8	80,7	19,3	4,6	76,0	110	0,3	80	50	Ni-25 Al-30
				0,4	2,5	97,0					
				14,7	0,5	84,6					
				30,4	2,5	67,0					
				45,5	1,7	52,6					
3	8,0	0,2	82,4	0,2	< 0,2	98,4	110	0,3	80	50	Ni-25 Al-10
				12,6	< 0,2	79,5					
				1,1	< 0,2	74,1					
				20,7	< 0,2	74,5					
4	32,2	0,2	52,1	0,4	< 0,2	99,4	110	0,3	80	50	Ni-25 Al-30
				51,4	< 0,2	39,4					
				35,0	< 0,2	58,4					
				45,1	< 0,2	39,8					
				45,1	< 0,2	39,8					

The results of chemical analysis show considerable variations of content in components of catalytic material at the local zones which points to the necessity of additional workout of coat application conditions and further research (phase and structural analysis) of catalytic material.

Coat photomicrograph of Al- γ Al₂O₃ system is presented in Fig.29 and Fig.30 shows photomicrograph of the same coat with additional application of Ni and Al by ion-plasma spraying method.



Fig.24 Still picture of Bulat installation

Substrate with film

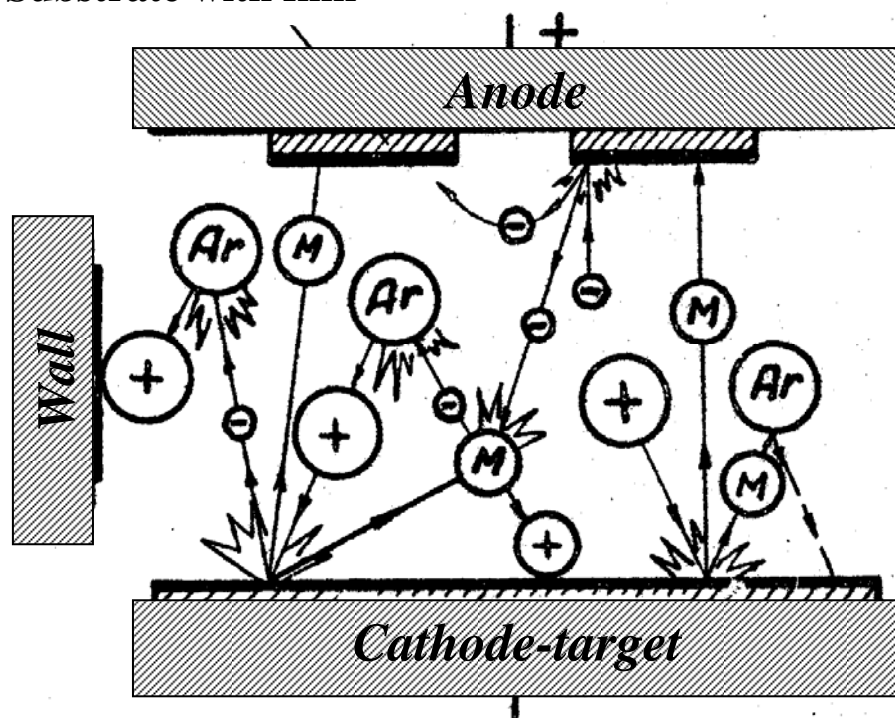

Fig.25 Scheme of metal film spraying on the substrate by cathode sputtering in diode system

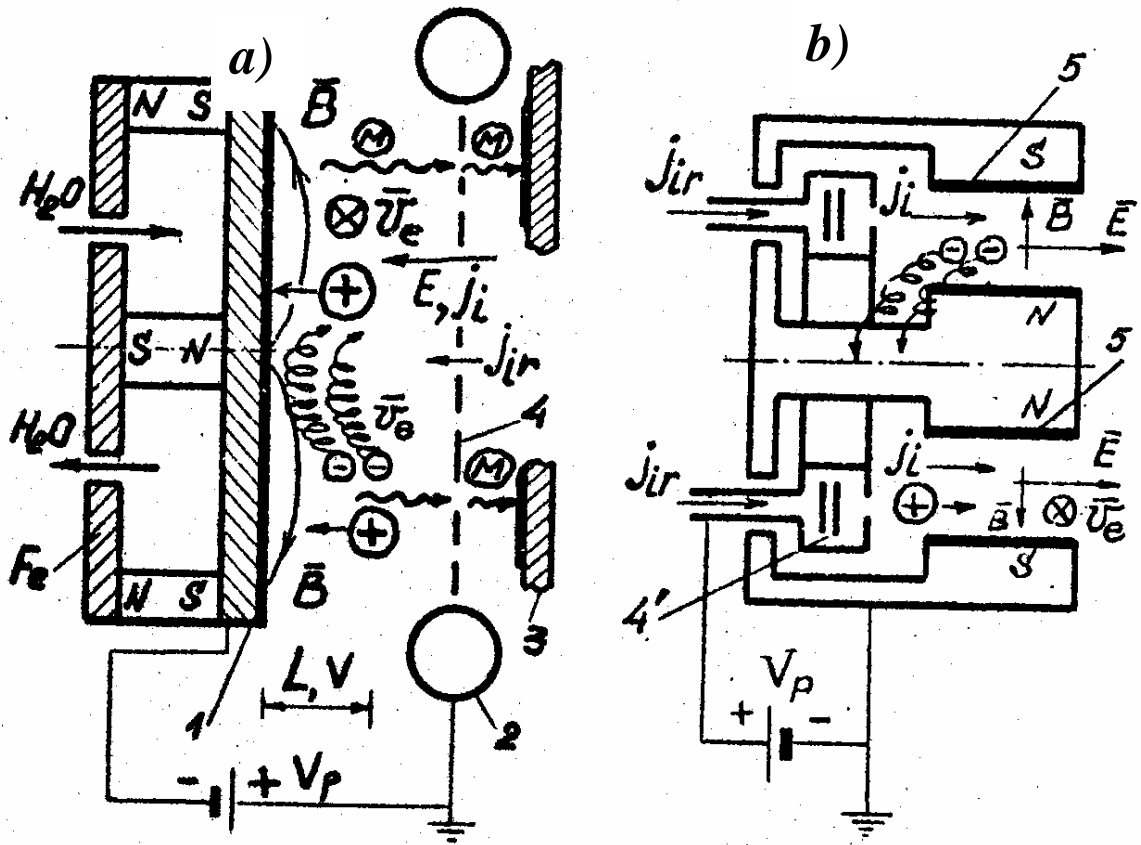

Fig.26 Circuits of magnetron (a) and plasma accelerator with azimuthal electron drift (b): 1 – cathode-target; 2 – anode; 3 – substrate; 4 – anode-gas-distributor; 5 – insulator

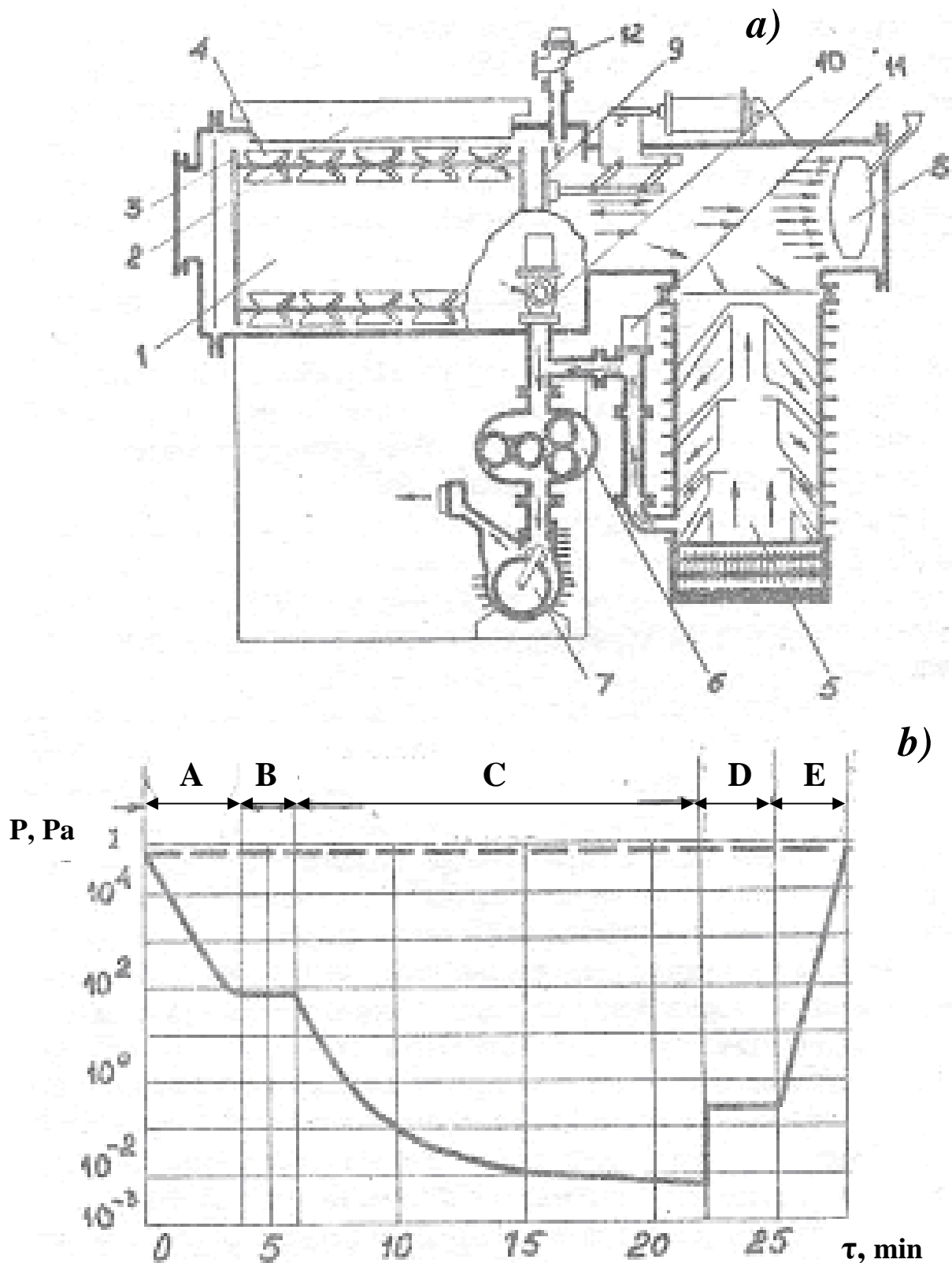

Fig.27 Scheme of installation (a) and sequence diagram (b) of magnetron spraying on substrate process: 1 – vacuum chamber; 2 – magnetron (cathode); 3 – substrate-holder; 4 – sprayed-on substrates. Pumps: 5 – diffusion pump; 6 – two-rotor pump; 7 – guided-vane rotor-type pump; 8 – cold trap. Bolts: 9 – high-vacuum seal; 10 – exhaust line damper. Valves: 11 – gas-ballast valve; 12 – air admission valve (A – forevacuum; B – glow discharge; C – high-vacuum pump; D – spraying; E – letting-to-air)



Fig.28 Still picture of Mir installation

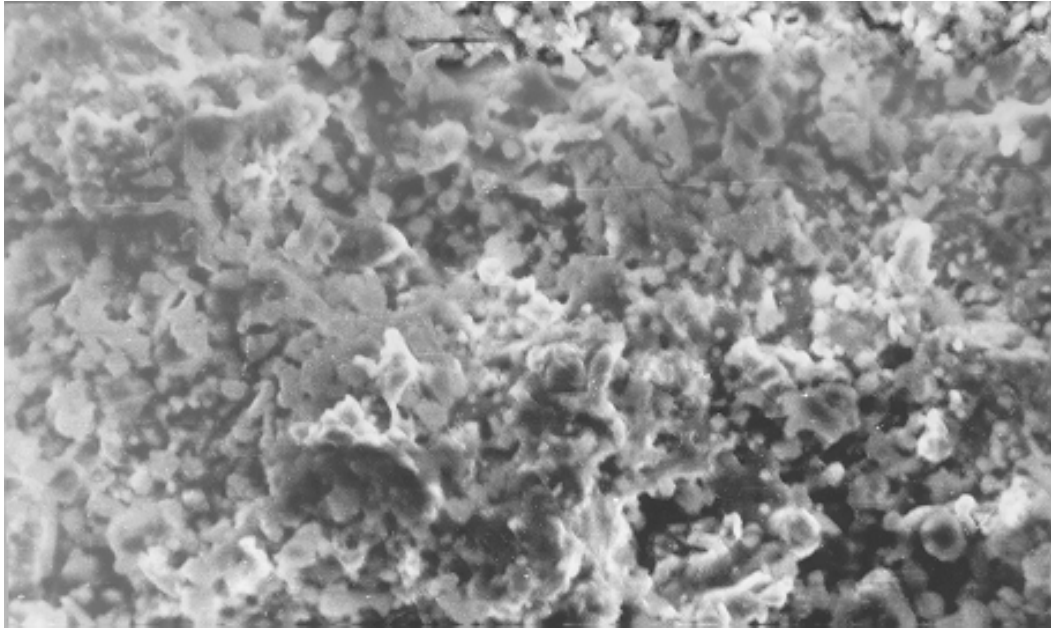

Fig.29 Scanning electron microscope. Coat photomicrograph (plasma jet spraying of the carrier of AL- γ -Al₂O₃ system)

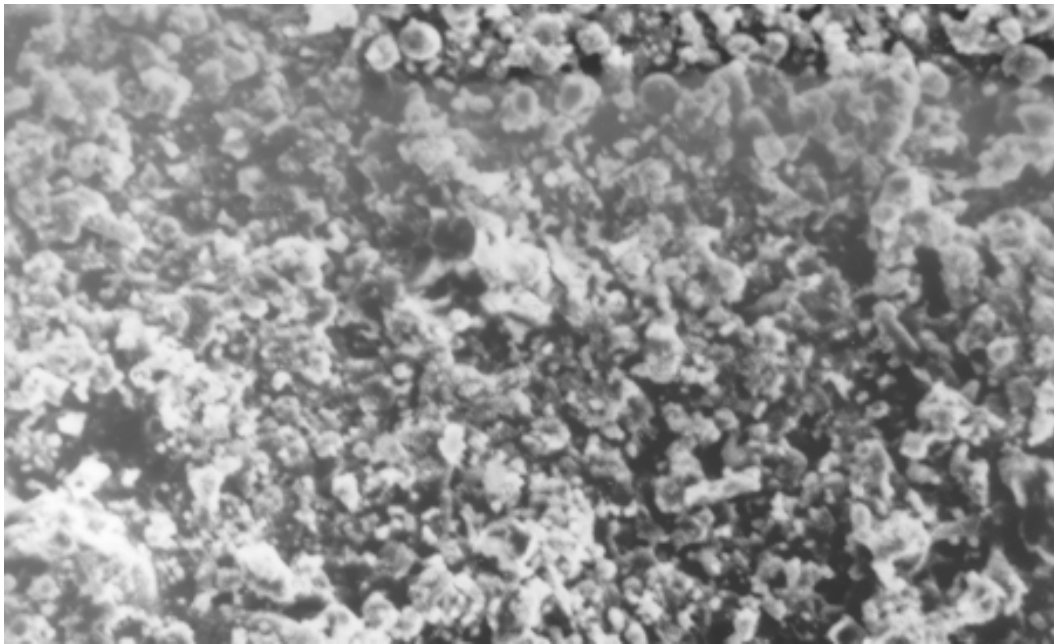

Fig.30 Scanning electron microscope. Coat photomicrograph (plasma jet spraying of the carrier on the basis of AL- γ -Al₂O₃ on metallic foil and ion-plasma application of nickel and aluminium)

8. EXPERIMENTAL INVESTIGATION OF THE CATALYST SAMPLES FOR THE FIRST STAGE OF STEAM REFORMING

Investigation of low-temperature steam conversion process of liquid hydrocarbons has been carried out in a flow reactor at atmospheric pressure in the temperature range between 350 and 500° C and mass relationships of steam-hydrocarbon within 2 – 3 limits.

The scheme of laboratory-scale test facility is presented in Fig.31. Distilled water from reservoir (1) is fed to metering pumps (2). Burettes (3) are designed for accurate measurement of liquid reagents volumetric flow rate. Both metering pumps operate in parallel and are rigidly synchronized. The phase of one of them is displaced by half a period in relation to the other resulting in attainment of uniformity of the reagent supply. One of the flows is directed right to the evaporator (4) and the second one is supplied to displacing reservoir (5) filled up initially with liquid hydrocarbon. The hydrocarbon flow enters the same evaporator. Valves 6, 7, 8 are used for cleaning of the reservoir (5) and for inert gas or hydrogen supply to the installation at the blow-down or catalyst reduction conditions. Within evaporator, vaporization and heating of reagent vapors up to the specified temperature takes place. The temperature is stabilized by electron regulator controlling power of the evaporator's heater. The gas mixture obtained enters the reactor (9). Samples of the catalyst under investigation are placed into the middle isothermic zone of the reactor, with the remaining reactor volume filled up with inert packing. The preset temperature is maintained by the second regulator channel. Products of the reaction are directed to the linear cooler (10) made from the stainless steel and return cooler (11). In the coolers, the gas mixture cooling and condensation of liquid components accumulated in the collector (12) occurs. Gaseous components bubble through the layer of concentrated H₂SO₄ in the wash bottle (13). This supplementary drying is necessary for prevention of the possible steam condensation in sample taking line for chromatography. Manostat (14) is needed for creation of excessive gas pressure at the sampling point. Volumetric flow rate of the exit gases is measured by gas meter (15).

All service lines between elements of the installation under pressure are executed in the form of metallic pipelines. To eliminate the possibility of fire hazard situation in case of emergency depressurization and fuel component leak (age), the installation is mounted in a hood.

The installation procedure of operation is like follows:

The reactor with a certain amount of catalyst is connected to evaporator and cooler. The installation is filled up with inert gas. Electric power supply is switched on and the required temperature for evaporator and reactor is adjusted on the regulator selectors. On reaching predetermined temperature, hydrogen supply for catalyst reduction is turned on. Time of reduction, hydrogen flow rate, and temperature are kept as per the specifications for this specific catalyst. Upon completion of catalyst reduction, metering pumps ensuring supply of the required water-hydrocarbon volumetric flow rates ratio are brought into operation. When steady-state temperature value is reached, chromatographic analysis of the composition of gaseous components of the reaction products is carried out. When the results of several consecutive analyses coincide, the operation conditions are considered standard. Measurements of mean values of volumetric water and hydrocarbon flow rates at the inlet are taken, as well as volumetric gas, water and hydrocarbon flow rates at the outlet. Temperature is also taken at several points along the catalyst layer. The installation switching off and the reactor cooling down is made during blow-through of the system by the inert gas to prevent air oxygen access to the layer of the reduced catalyst.

Temperature, pressure, rate are measured in conformity with the known methods. A unique method has also been developed that makes possible joint analysis of gas mixture comprising components H₂, CO, CO₂, CH₄ by the use of a single chromatograph with thermal-conductivity detector.

General hydrocarbon conversion degree has been determined from material balance on the basis of measurement of hydrocarbon rate, converted dry gas volume and composition.

Activity of catalyst samples was judged by the value of general hydrocarbon conversion degree, activation energy and process rate constant which have been determined from integral characteristics of the process with consideration for the accepted type of kinetic equation.

Figs.32 – 35 show typical curves of variation of the indexes of low-temperature n-heptane conversion process depending on hydrocarbon flow rate at the inlet to the reactor at the same mean catalyst temperature. The process was carried out on the catalyst samples (nickel content 49 % by mass) promoted by potassium oxide.

To compare degree of deviation from equilibrium of current characteristics at the outlet of the reactor, equilibrium design values of component concentration in the dry converted gas are presented in Figures. Throughout experiments conducted catalyst coking has never been observed. Hydrogen oxide concentration in the dry converted gas was extremely low and therefore it is not referred to. From the presented data it follows that the process is being completed far enough from equilibrium due to insufficient duration of mixture stay in the reactor.

As the rate of reaction mixture at the reactor inlet increases, the process time decreases and, consequently, so does depth of n-heptane conversion and methane concentration in the flow.

Considering the excess and permanent steam rate, the ratio steam-methane under formation is growing with mixture rate increase resulting in the conversion rate variation, on the one part, and shift of equilibrium of its reaction steam conversion towards the products – hydrogen and carbon oxide (CO), on the other part.

Interaction between paraffins and steam can be divided arbitrarily into three main stages:

1. Catalytic cracking and dehydration; thermal cracking under high temperatures leading to the formation of lowest olefins, methane and some amount of hydrogen mainly.
2. Reaction of parent intermediate substances with the steam which leads to the formation of hydrogen and carbon oxides.
3. The stage of approach to equilibrium between H₂, H₂O (steam), CO₂, CO and CH₄.

Obviously, it is unlikely that Stage 2 consists of elementary chemical processes, but appropriate intermediate substances have not been detected.

Depending on the catalyst used and conditions of the low-temperature process of hydrocarbons conversion, methane-carbon oxides ratio can vary over a wide range bearing witness to the complexity and multirouteness of the stage of hydrocarbon primary transformation. Probable balanced schemes of transformation resulting in various ratios of methane-carbon dioxide for n-heptane without regard for coke formation look like follows:

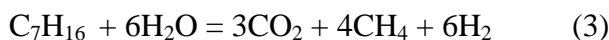
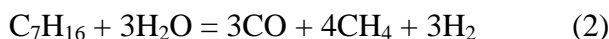
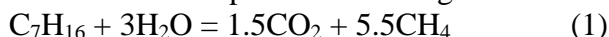

Simultaneously, depending on conditions in the forward or in the opposite direction, the following reactions proceed:

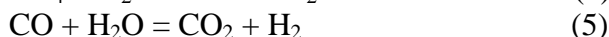
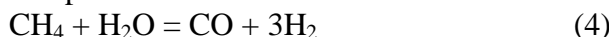

As of today, the available literature sources and our own experimental data do not allow in a unique fashion to talk about the mechanism of low-temperature conversion of methane homologues and motor fuel.

Of a great scientific and practical interest would be to conduct a special series of experiments on conversion of light C₃ – C₅ liquefied alkanes, heavy C₈ – C₁₀ alkanes and aviation kerosene fuels of the JP type. It is necessary to clarify possible mechanisms of the conversion process and learn to obtain the required composition of the conversion yields for their application in the propulsive and energetic installations as well as in the chemical industry.

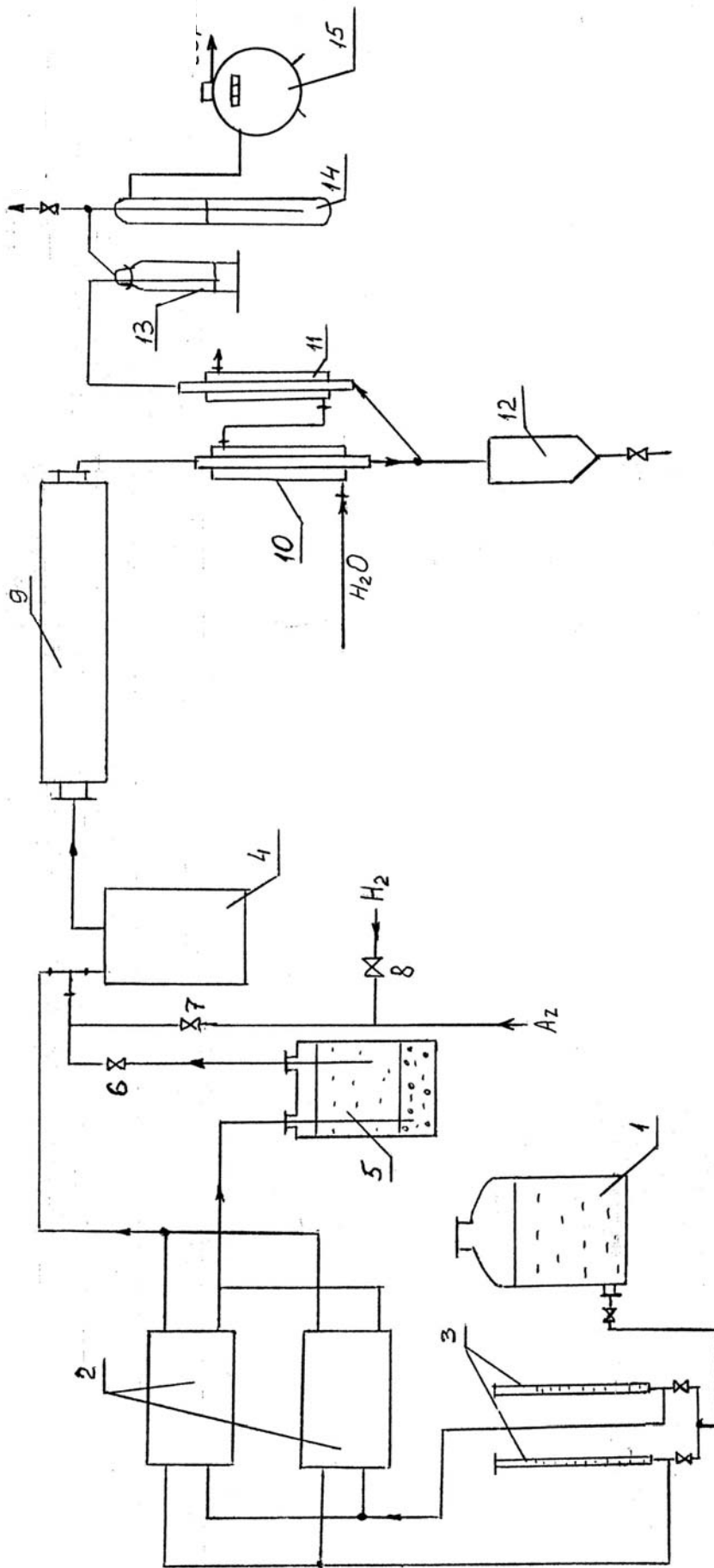

Fig. 31 Experimental set-up for liquid hydrocarbon conversion.
 1 –distilled water reservoir; 2 –metering pumps; 3 –burettes; 4 – evaporator; 5 –displacing reservoir; 6, 7, 8 –valves;
 9 –reactor; 10,11 –coolers; 12 –collector; 13 –wash bottle; 14 –manostat; 15 –gas meter.

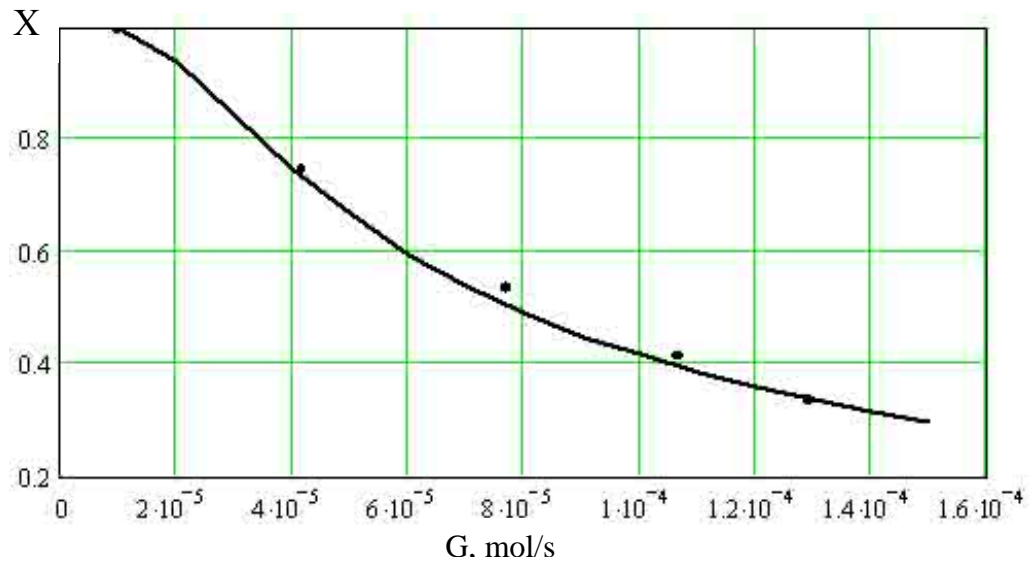

Fig.32 Heptane [C₇H₁₆] rate effect on degree of conversion (X) at T = 400° C. Solid circles – experiment, the curve – approximation.

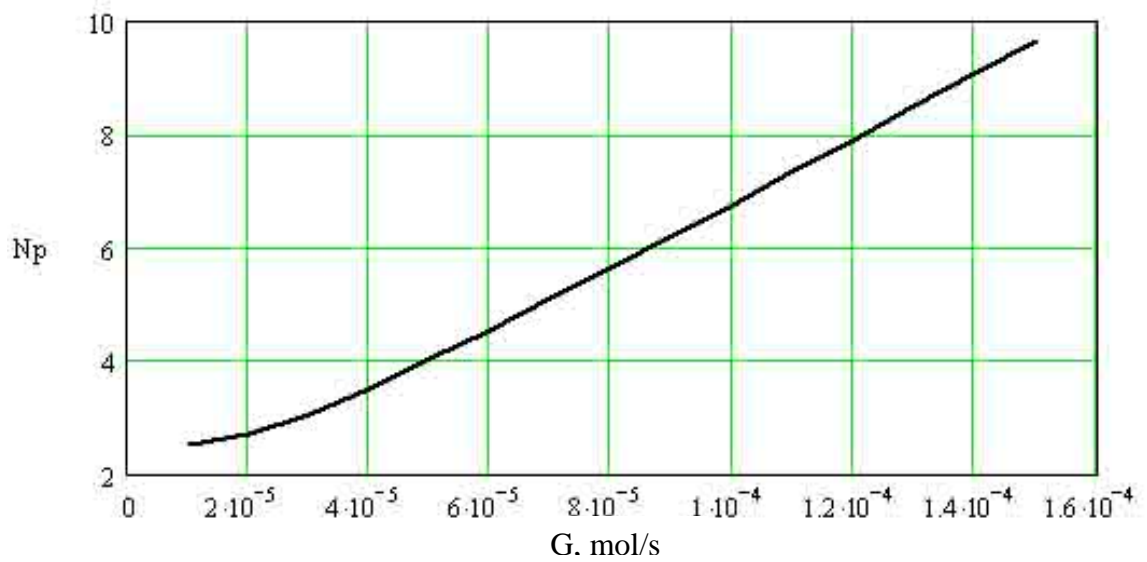

Fig.33 Heptane rate effect on the molecular steam-methane (Np) ratio at T = 400° C

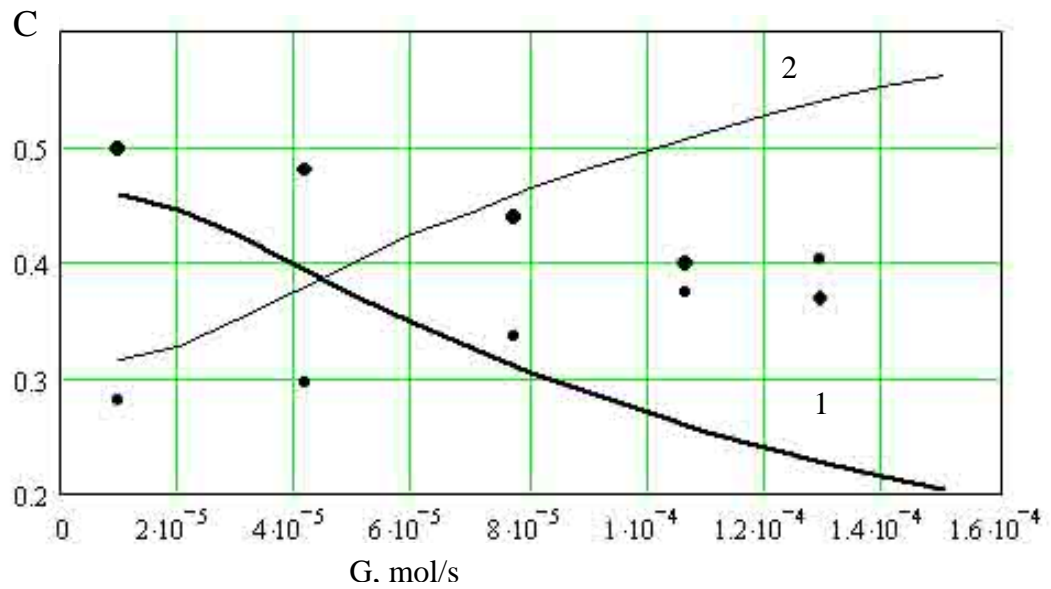

Fig.34 Heptane rate effect on methane and hydrogen concentration in the dry converted gas at $T = 400^{\circ} \text{C}$. Solid circles – experiment, the curves – the design equilibrium concentrations.

•, 1 - CH_4 ; •, 2 - H_2

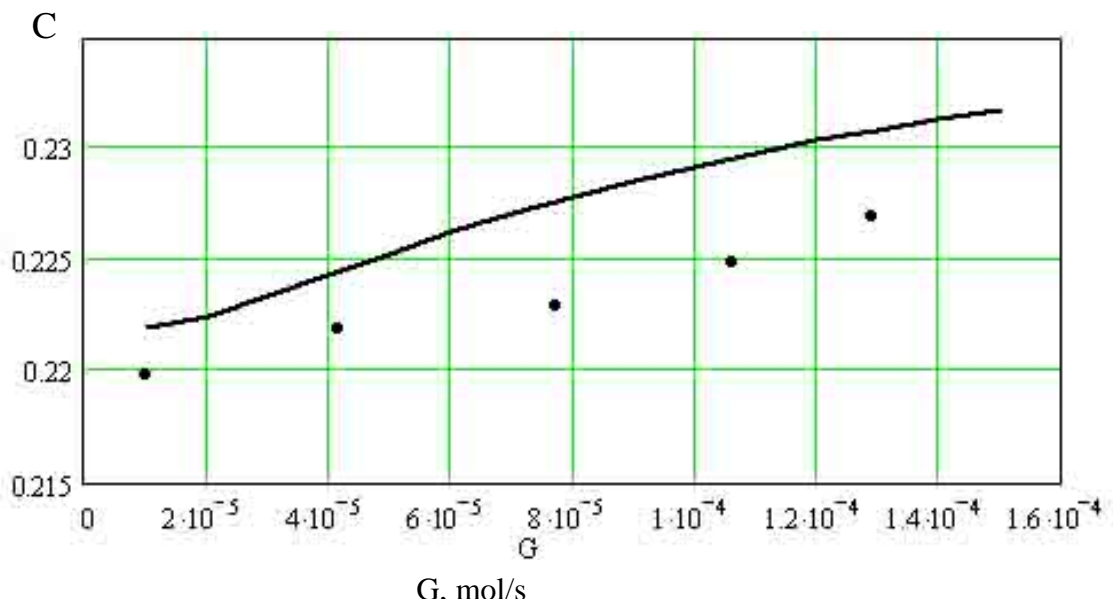

Fig.35 Heptane rate effect on the carbon dioxide concentration in the dry converted gas at $T = 400^{\circ} \text{C}$. Solid circles – experiment, the curve – the design equilibrium concentration.

9. COLD GASDYNAMIC SPRAYING METHOD FEATURES

In modern practice the world over, to obtain metallic coatings, gas-thermal methods are widely used. In the known procedures of gas-thermal spraying of powder materials on the underlying surface they use high-temperature two-phase streams in order to get high adhesion.

Coating formation occurs at the interaction of the underlying surface with the melted (or nearing this state) particles of the sprayed-on material. For realization of this mechanism, high-temperature ($> 1000^{\circ}\text{C}$) gas flows are used (plasma explosion energy, thermal energy of gas combustion, electromagnetic beam).

Such high-energy flows can be produced through the use of rather expensive and relatively complicated from the technical viewpoint devices, like plasma generators, gas flame burners, detonation guns, electron-beam installations, lasers, etc. It should be noted that methods of gas-thermal application of metallic coatings have some specific features that limit the possibilities of their usage.

Thus, in particular, complicated physical-and chemical interaction processes of the sprayed materials with the gas phase that appear as a result of spraying (formation of oxides, nitrides, carbides, structural changes and so on), as well as high thermal-and-mechanical stresses (due to different coefficients of thermal expansion of underlying surface and coating applied) significantly reduce the quality of the coating and adhesion between the material and underlying surface.

Traditional equilibrium alloys, methods of their production and treatment have already reached a certain technical point following which experts tend to prefer non-equilibrium materials with amorphous, microcrystalline and n-phase structures. Constantly increasing interest toward these materials is conditioned by high level of their physical-and mechanical, magnetic, electric, catalytic and other properties. This offers extensive potentialities of their wide application in the products of a new advanced technology.

As is known, a specific feature of non-equilibrium materials is the fact that at a temperature of $(0,4-0,6) T_{\text{liq}}$ degradation of structure takes place and, accordingly, deterioration of physicochemical properties. That is why for application of the above materials it is necessary to ensure a considerable temperature decrease of the gas flow with the observance of the narrow temperature-stable parameters of the spraying process demanding usage of the new highly efficient techniques. With the spotlight fixed on the new category of non-equilibrium materials, an extensive search for the novel technological solutions goes on continuously having proper regard to the above specific features of these materials.

One such method is cold high-velocity gasdynamic spraying. The method, in essence, consists in application on the surface of individual powders or their compositions by means of supersonic gas flows. It can also be used for connection of structure components as an alternative to soldering and welding processes. Powder material comprising fine dispersed particles ranging in size from $1\mu\text{m}$ to $120\mu\text{m}$ accelerates in the supersonic nozzle by compressed gas flow to $300 - 1200\text{ m/s}$ and is directed to the treated surface. The temperature of the transferred particles, at that, is much less than their melting temperature and makes around 100°C . Thus, the cited method is devoid of many limitations of high-temperature plasma techniques but can boast the following merits:

- the particles are transferred in a “cold” state with transport rate up to 2M and more;
- the particles heating is accomplished at the expense of kinetic energy transformation into thermal one in the process of interaction with the surface , i.e. directly at coating formation;
- possibility to obtain coatings adequate in composition to the sprayed powder;
- lack of the noticeable thermal impact on the underlayer material that could result in the product deformation;
- safety, simplicity and economic feasibility of the process.

Due to these advantages, this technique finds extensive application in various technological processes.

Coating formation by CGDS consists of several consecutive stages. At the front of the moving two-phase flow, the particles are bombarding the surface, producing microrelief on it with resultant surface activation. The most high-energetic particles of the mid-flow interact with this surface. The formed-up monolayer facilitates later on formation of poreless and durable coating. To enhance coating quality and increase powder utilization factor, it is recommended that powders with 50 μm optimal size of the particles be used.

The setup for producing coats through the use of CGDS method consists of the following principal parts (Fig.9):

1. Compressed air cylinders;
2. Air purification system;
3. Ohmic heater of the working gas (air);
4. Laval nozzle;
5. Setup control console;
6. Feeders(dozers).

Compressed air after purification system is fed into ohmitic heater chamber. It is heated there to the working temperature and supplied to the supersonic nozzle. Sprayed-on powder goes from the feeder to the nozzle area and is captured by the passing air. At the outlet of the supersonic nozzle, high-velocity hetero-phase jet of “hot air – powder” mixture is formed .

The most important factors of CGDS process governing strength of adhesion of the applied dispersed particles to the bottom layer is the gas flow rate, as well as temperature and velocity of the sprayed-on particles.

By changing modes of equipment operation it is possible either to carry out surface erosion pre-treatment in order to ensure chemically clean surface or to apply homogeneous coatings or composite coats of mechanical mixture of powders with preset complex of physicochemical properties. Variations are also possible to achieve by appropriate change of hardness, porosity and thickness of the sprayed-on coating.

Cold gasdynamic spraying method allows film deposition with controllable set of properties and thickness ranging from 10 μm up to several millimeters.

9.1 EXPERIMENTAL INVESTIGATIONS

Practical realization of CGDS technique is determined by ability to measure and control basic technological parameters of the process, namely – velocity and temperature both one-phase and two-phase flow. Actually up till now, we have made no research in this particular field and therefore the objective of this work was also the development of appropriate instrumentation and control techniques for the above technological parameters. So, the main parameters of coating application (concerning temperature and velocity) have been thoroughly studied and optimized experimentally. Measurement of gas rate in supersonic flows has been performed using signals of the sensors of both total and static heads. To obtain absolute values of the flow rate at the point under investigation it is necessary to know (apart from Mach number) the stagnation temperature, too. It was being measured by a special thermocouple probe equipped with stagnation camera.

Gas flow rates at various distances from the nozzle exit section and under different temperatures have been calculated on the basis of the experiments aimed at the investigation of a one-phase flow. The computational results are presented in the Table12.

Table 12**Computational results of one-phase flow rate**

Distance from the nozzle exit section, mm	Flow rate, m/s	
	Temperature 291 K	Temperature 723 K
0	330	523
2	407	641
12	394	622
96	123	194

At the development of the process regimes of coat application, the optimal distance is identified where spraying process runs with the maximum powder utilization factor. According to the experiments conducted, this distance makes 15 mm. Within this distance, the gas flow rate makes 650 m/s with the temperature of totally stagnated gas 450° C (Fig.36), while particles temperature does not exceed 100° C.

The data obtained point to the features of CGDS process and are of great importance at the development of spraying techniques for the concrete material compositions.

For the measurement of particles velocity in the flows (scattering centers therein) some methods are used based on the homodyne reception of the scattered laser radiation but these methods have limitation of the upper velocity measured over 300-400 m/s range. Even at such upper limits of the velocities under diagnostics, homodyne methods using the most appropriate differential diagram of measurement, give but too small spatial resolution and, as a rule, are in need of high-powered lasers (10 – 20 mW). For the flow rates 300-800 m/s and over it would be rational to use methods of direct optical Doppler detection scattered in the light flux based on the operation of instruments of super-high spectral resolution. One of such spectral devices is spherical Fabry-Perot interferometer. Manufactured on its base laser-Doppler high-velocity flow rate meter makes it possible to study flow lower speed values equal to 1500 - 2000 m/s without loss of the spatial resolution and using low-powered lasers (~ 1mW). Observation area of Doppler flow rate meter has been specified experimentally. Its diameter is pinpointed by that of laser beam (2.5 mm), and distribution of sensitivity along the beam is shown in Fig.37.

The main merit of such methods is low sensitivity to the nature and concentration of scattering centers in the flow.

Particle velocity measuring has been performed on CGDS setup at 15 and 50 mm distance from the nozzle exit section at various feeder productivity and working pressure. Average results are presented in the Table 13.

Investigations of powder utilization coefficient depending on the flow velocity have shown that at the flow velocities below “critical” ones (insufficient for the particles fixation), the process of powder erosion impact upon the substrate surface occurs. With increase in the gas flow velocity, formation of coating begins on the surface and powder utilization coefficient increases from the values close to “0” up to 0,4 – 0,8 (Fig.38).

Table 13**Particle velocity at the selected technological parameters**

Distance from the nozzle exit section, mm	Capacity, g/s	Particle velocity, m/s, under operating pressure		
		0,6 MPa	0,55 MPa	0,5 MPa
15	1,52	316,9	304,9	332,30
	0,75	308,1	306,3	300,0
50	1,52	177,3	238,5	286,2
	0,75	220,7	318,1	318,1

As is well known, the bond of coating with the base (substrate) is a crucial characteristic of the coating. Coating adhesion with substrate, strength of interlayer boundaries, as well as cohesive strength of separate layers are indicators determining many functional characteristics of

the parts with coatings. Variety of shapes of the coated parts, conditions of their operation, techniques of coats production, ranges of their thickness and degree of strength, predetermine diversity of techniques and procedures associated with determination of strength properties.

Depending on the character and degree of accuracy of the technological problem to be solved different quantitative and qualitative methods are being resorted to. Guided by appearance of the applied loads, they use bend, shift, detachment and complicated state of stress. Of the utmost importance when evaluating coating quality are properties of not only surface layers but also of transition zone at the boundary between coating and substrate.

Ideally, adhesion testing has to ensure quantitative assessments and provide for a wide assortment of coating thicknesses. Therefore, to determine adhesion strength of the coatings obtained through the use of CGDS technique the measurements were taken using a dowel pin.

Adhesion strength was being determined on the adhesion samples during tests in tearing machine. It was found that adhesion strength depended mainly on high-speed parameters of heterophase jet "air + sprayed-on powder" (Fig.39).

Temperature impact of sprayed-on particles can be neglected: the experiments had shown it did not exceed 100° C over the whole range of powder spraying rates (Fig.40).

Of special note is the fact that heating of the particles in a 100° C flow does not have, in our opinion, a significant effect on the material plasticity and, consequently, adhesion amount of the coating applied. For this CGDS process, particles temperature is not a critical one when defining criteria of the technological modes.

The principal feature of the spraying process as per selected technological modes is also availability of the critical mass flow rate of the sprayed-on particles below which level the coating cannot be formed no matter what time of the two-phase jet impact would be.

Even the first experiments on the interaction of powder particles with substrate clearly indicated that at the initial stage the particles of the heterophase flow front, elastically deforming, bounced off the substrate due to insufficient velocity and concentration in the flow. On the substrate surface craters appear, oxide film breaks forming juvenile surface.

The interaction of the front particles at the first stage ensures conditions for creation of the durable bond for the formation of a stable solid coating. Erosion of the base also contributes to the particle fixation in so far as the contact area with the juvenile sites of the surface increases.

The nature of interaction of the particles with the surface was studied on the samples with 30-mm diameter using microscope of NeoPhot type (Fig.41).

Fig.41 shows interaction area of particles with substrate during the first stage of coating formation

Here, partial fixation of the sprayed material could be observed as well as the craters that have been formed as a result of elastic interaction of particles with substrate. Dependence of powder utilization coefficient on the spraying angle also plays a decisive role in the process of the dense coating formation. In the range of values 80 - 90° C the utilization coefficient is practically constant but starting with 75° it rapidly decreases.

By way of demonstration of CGDS advantages, it was shown experimentally that at the selected technological modes it is possible to preserve without oxidation sprayed composition Al-Zn (Fig.42).

High coating adhesion to aluminum substrate is achieved at that, and a reliable consolidation of the elements is assured when assembling thin-wall laminated and ribbed structures.

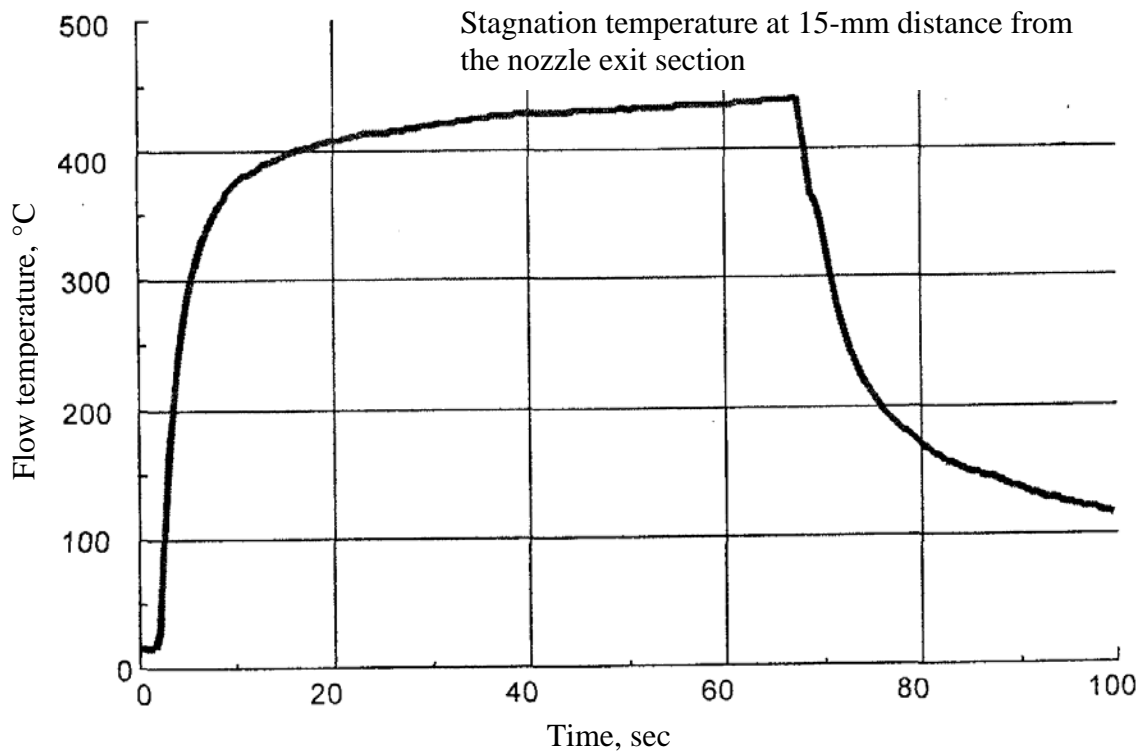

Fig.36 Time dependence of stagnation temperature of gas flow variation when going in the operating mode

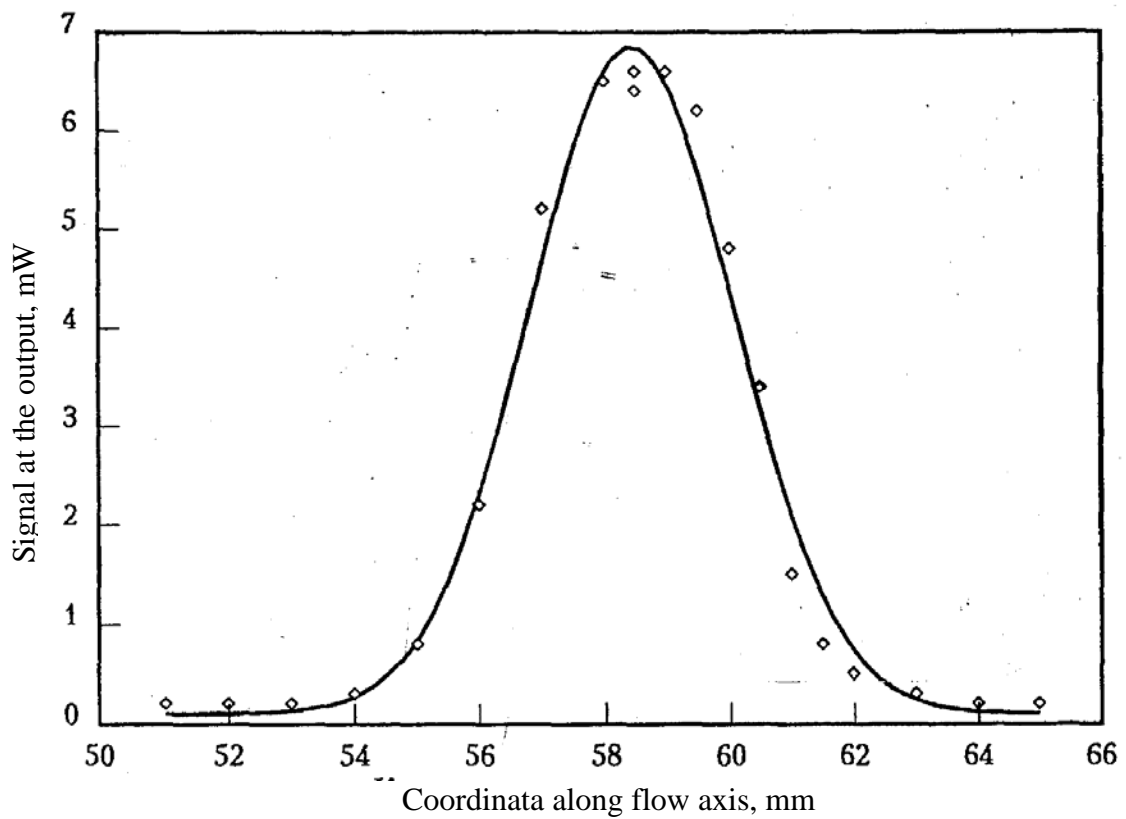

Fig.37 Distribution of spatial sensitivity of laser-Doppler flow rate meter

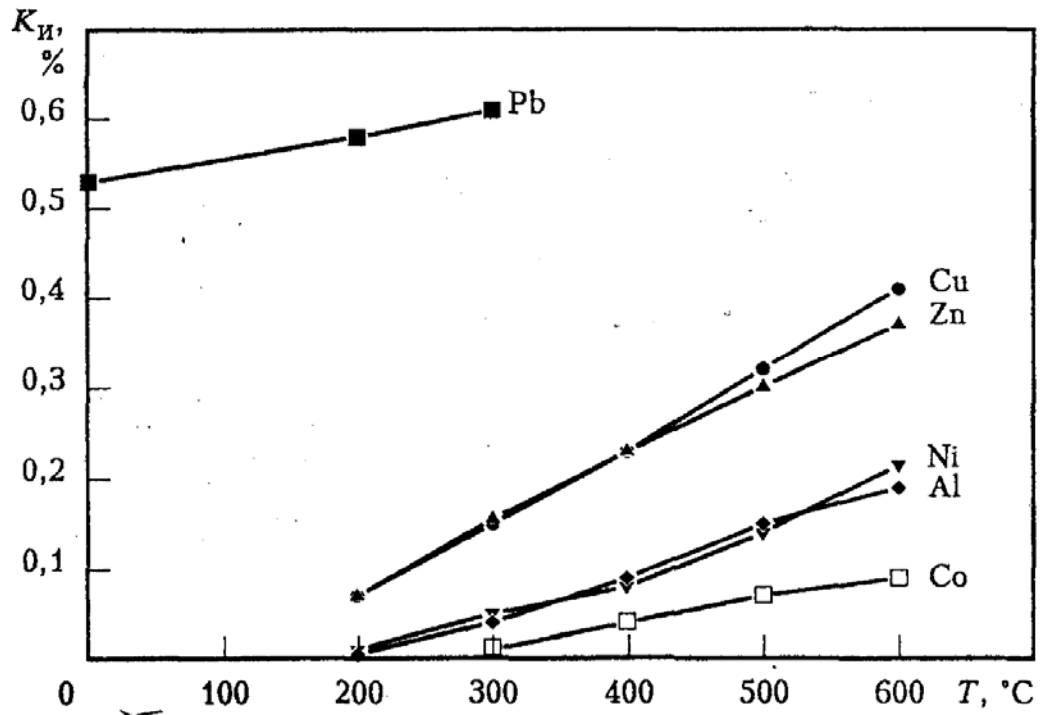

Fig.38 Dependence of powder utilization coefficient on the gas flow temperature

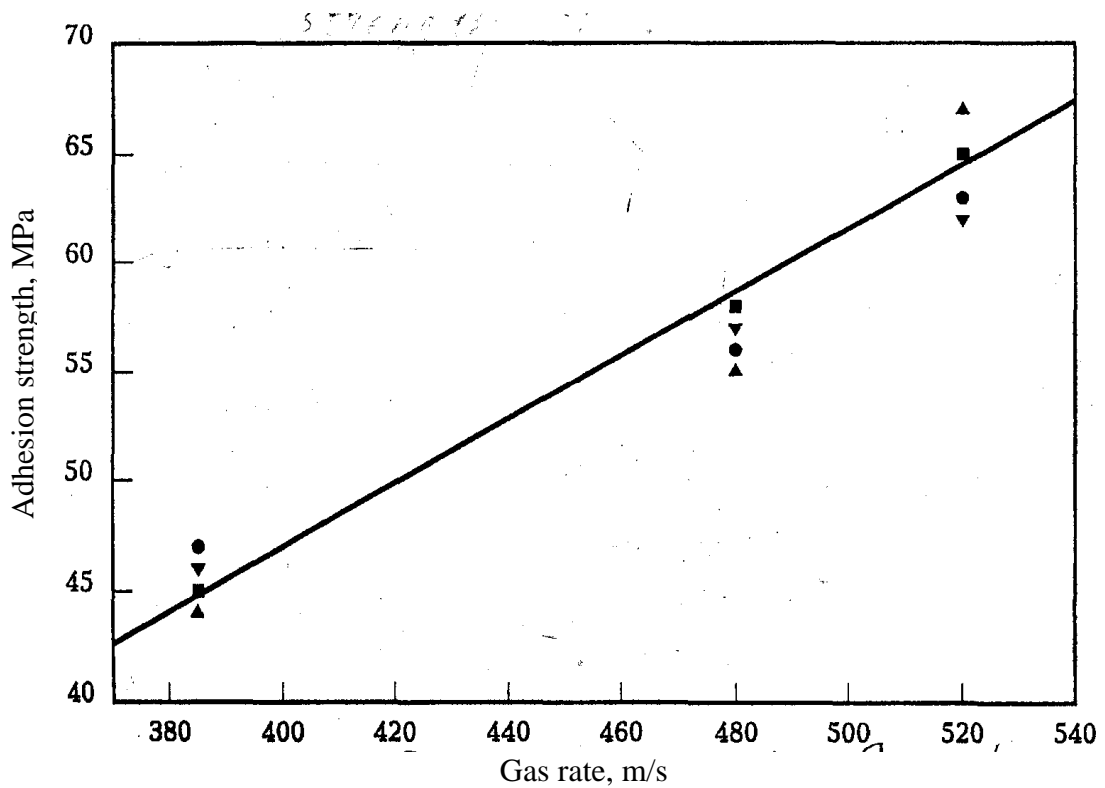

Fig.39 Dependence of adhesion strength on gas rate
(points: mean selected data on adhesion strength determination)

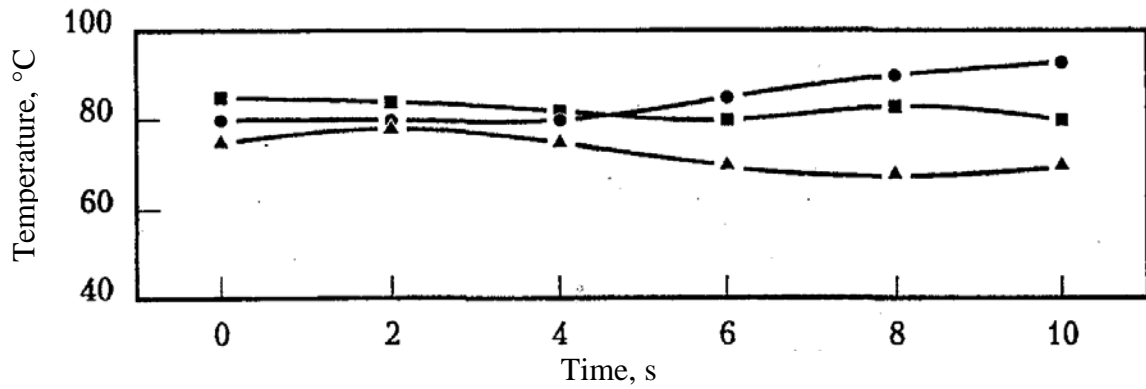

Fig.40 Statistic temperature of aluminum powder at the 20-mm distance from the nozzle exit section:

- - velocity 193 m/s, powder consumption 1,52 g/s; ● - velocity 224,7 m/s, powder consumption 1,52 g/s; ▲ - velocity 220 m/s, powder consumption 2,0 g/s

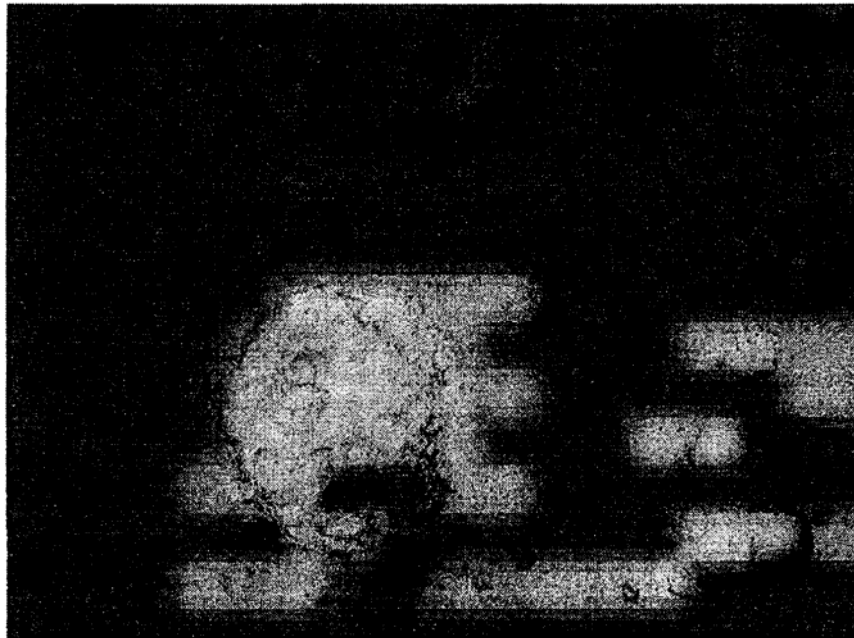

Fig.41 Photography of the polished substrate after its interaction with aluminum particles ($d_p = 50 \mu\text{m}$) x 1000

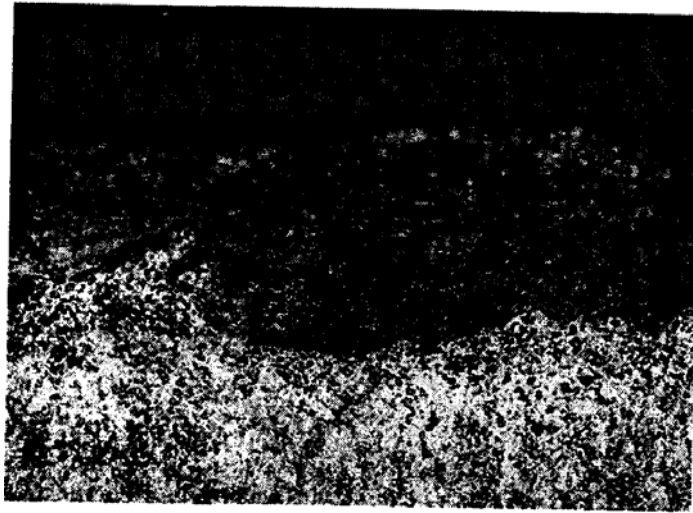

Fig.42 Composition Al – Zn sprayed on substrate from aluminum alloy

The most important factor of CGDS process, that is able to determine cohesive strength of the applied dispersed particles to the substrate is the velocity of the particles V . Our experimental investigations, along with those of other authors, demonstrated availability of some critical velocity $V_{cr} \approx 500 - 600$ m/s of particle interaction with the substrate, below which the process of surface erosion could be observed. In this case a particle has but the only chance to get fixed on the surface while being in contact with the substrate and that is to collide with another counterpart that would prevent its bouncing off. At $V < V_{cr}$ particle spraying coefficient $\Delta m/M$, characterizing accretion support of the substrate mass Δm to the total mass M of the powder spent is very small, indeed ($\Delta m/M \sim 10^{-3} - 10^{-4}$). At $V > V_{cr}$ adhesion strength start to surpass repulsion force which leads to gradual formation of the solid layer on the substrate surface. With further increase in velocity spraying coefficient sharply increases.

The results of these investigations are shown in Fig.43 in the form of dependencies of spraying coefficient of particles with $d_m = 10 \mu m$ on the velocities of their fall on the substrate for some metallic powders frequently used at preparation of the catalysts for various processes. It can be seen, that for the given materials at the velocity range 500 – 600 m/s that presents transitional area from the 1st ($V < V_{cr}$) to the 2nd ($V > V_{cr}$) mode, sharp increase of spraying coefficient occurs. So, for the Al particles sized 1 – 50 μm ($d_m = 10 \mu m$) when increasing their speed by 400m/s (from 600 – to 1000m/s), spraying coefficient increases by almost four orders of magnitude greater (from 10^{-4} up to 0,8) which is of a great practical importance from the viewpoint of productivity increase of sprayers and powder utilization factor.

In-depth analysis of the technical characteristics of the sprayed-on layer in the 2nd mode, based on the study of macrostructure, adhesion-cohesion properties and so on has shown that under these conditions it is possible to provide for sufficiently good coating properties, especially if we speak in terms of adhesion and cohesion in the first place ($2 - 8 \text{ kg/mm}^2$). True, if compared to the 1st mode, there has been observed a decrease in coating solidity and considerable increase in porosity (up to 10 %). Such changes can be easily explained quantitatively, if we consider decrease in effect of impact compression by falling particles layer due to abrupt increase of spraying coefficient responsible, accordingly, for decrease of packing effects, deformation and layer solidity.

Thus, by changing velocity of Al particles from 500 to 800 – 1000m/s it becomes also possible to change over a wide range coating properties, for example, their porosity (from 1 to 10 %), layer' width (from 20 -30 μm up to mm and even higher) and so on. It should be noted that spraying coefficient at that changes from 10^{-3} to 0,8 enabling application of this method not only for deposition purposes but for acquisition of compact powder materials.

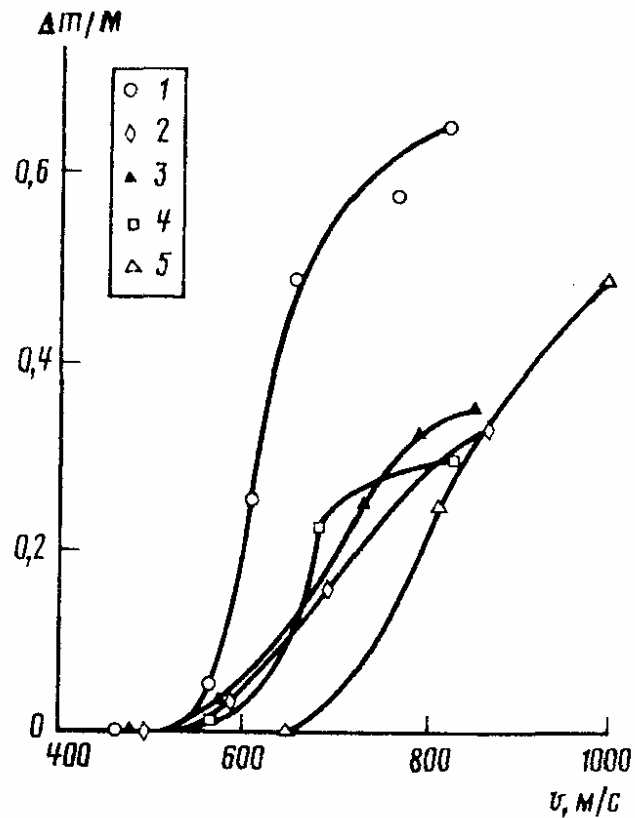

Fig.43 Spraying coefficient dependence on velocity for the powders of Cu(1), Zn (2), Fe (3), Ni (4), Al (5) ($d_m = 10 \mu\text{m}$).

One of the ways we resorted to in order to change heterophase flow velocity was heating up of the working gas in the fore-chamber that resulted in the sound increase in the jet and its speedily issuing from the nozzle. This effect found its illustration in Fig.44 with the dependence of gas flow velocity on the distance from the nozzle at different temperatures ($T = 291\text{K}$ and $T = 723\text{K}$).

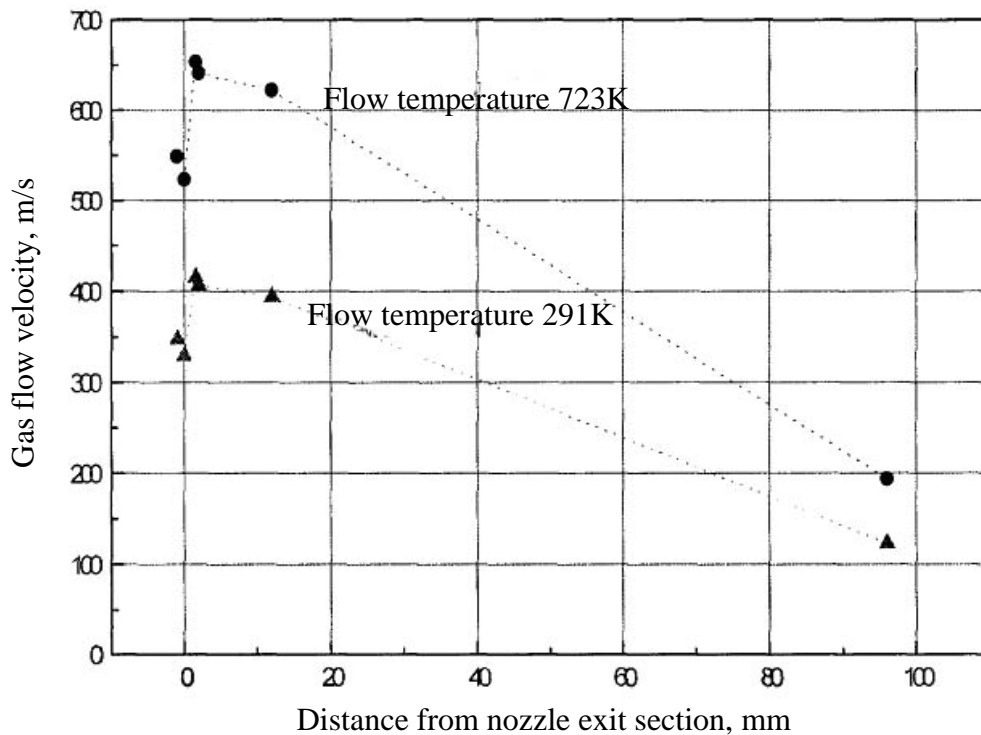

Fig.44 Dependence of gas flow on the distance from nozzle exit section

A catalytic coating is functional-gradient one because its layers fulfill many functions. It is not a rare occasion when the materials of the substrate and sprayed-on layer are differ greatly as to their crystallization structure and expansion coefficients. The technique of deposition of functional-gradient materials have been first tried when attempting to obtain wear-resistance coatings of different classes. Wear-resistance is a must for catalytic coatings, too, as they could find various applications in different energy setups with possible high velocities of chemically reacting mixtures.

The experience with deposition of FGC witnesses that to obtain the applied wear-resistance material monolayer two principally new technology could be used.

The first technological scheme:

Layer-by-layer spraying on, say, Al substrate of mechanical mixture compositions of the powder carrier with wear-resistance material and subsequent sputtering of peripheral layer of ware-resistance coating. (Alternatively, non-equilibrium alloy of the system Fe-Si-C has been selected to act in this capacity).

Application of this scheme shows that sprayed-on mixtures, as such, with various content of Al plasticizer have a good adhesion with Al substrate and at the expense of some porosity have significantly lower elastic properties, ensuring in the long run, better implementation of the sprayed-on ware-resistance powder.

The second technological scheme:

Using two autonomous dozers gradient coating compound is sprayed-on. First, dozer #1 is switched on for spraying-on monolayer consisting of pure Al. Then the dozer #2 comes into play with its wear-resistance material. Both devices operate simultaneously but the crux of the matter is lies in gradual decrease of the powder share from the dozer #1 and increase of wear-resistance material toward peripheral areas of the dozer #2. Variation in composition takes place according to the linear law. Creation of such gradient is provided for by the necessary compatibility of the initially incompatible materials.

To solve this problem, the first pattern of spraying has been given preference, test-operated and optimized. Realization of this version has been executed as per the technological scheme described below. First mechanical mixtures have been proportioned by blending of Al powder composition with wear-resistance powders. Then obtained mechanical powder mixture was subjected to the disintegrating treatment in order to obtain activated powder of homogeneous composition (Fig.45).



Fig.45 Still photography of composite powder

To activate powder (for the purpose of this paper we shall further understand the word “activation” as powder’ ability for active interaction) we have used method based on high-velocity shock treatment of powder materials. As activation processes occur both selectively and with various velocities in the local areas of the particle surface, the number of treatments run was increased up to three times.

As a result, we have obtained activated powder mixtures of three different compositions:

- Al 50% by weight - wear-resistance coating 50% by weight
- Al 20% by weight – wear-resistance coating 80% by weight
- Al 10% by weight – wear resistance coating 90% by weight

Following inspection of the composites obtained, it was determined that the powders fractional composition comply with the technological requirements allowing for their deposition by CGDS, having at that normal particle size distribution (Fig.46).

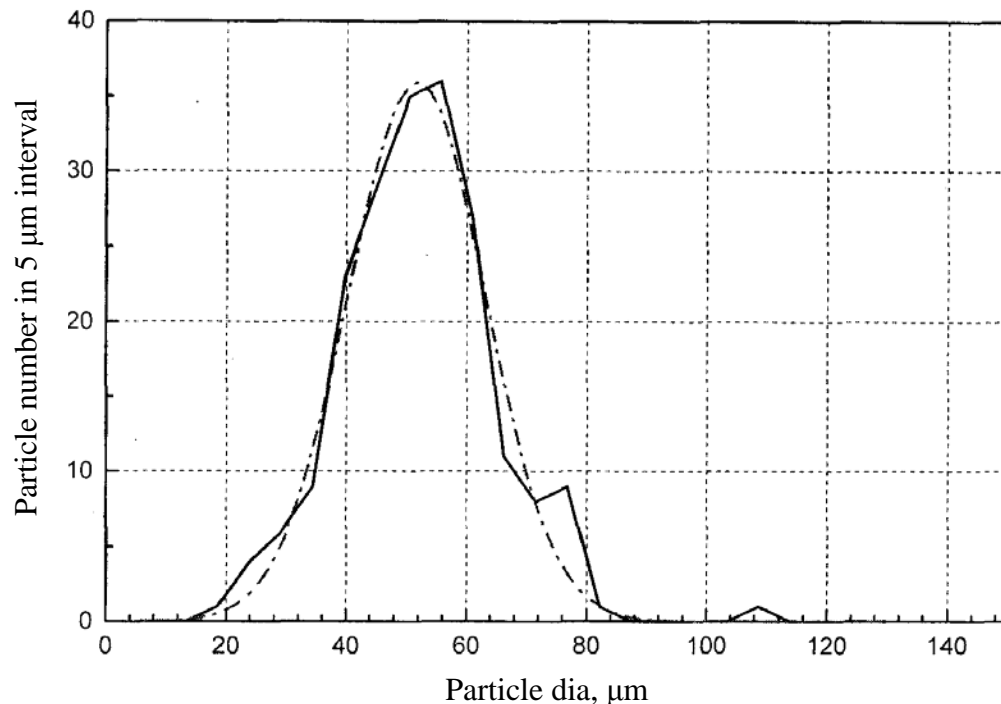

Fig.46 Particle size distribution

Experimental samples deposition by spraying has been performed according to the following technological procedures:

- static temperature of the gas flow has been permanent and equal to 450° C;
- heterophase jet velocity makes 220 m/s;
- optimal distance where spraying occurs is 30 mm;
- total width of each monolayer is from 100 to 200 μm at the dozer efficiency 0,5 g/s

Manufactured new samples have been subjected to microhardness tests. It was established that following coating of samples by spraying, their microhardness increases almost twice as much – actually up to 160-170 HV as compared to the initial Al substrate microhardness equal to 65-70 HV. It should be noted, that all tests have been performed using Vickers method. X-ray micrography showed that composition and structure of the new coatings appeared to be in an analogous way with the initial composition, wear-resistance powder (Fig.47) and nonequilibrium structure that prove potentialities of the CGDS method for production of coatings from structurally-sensitive materials of nonequilibrium class.



Fig.47 Cross-section of gradient coating (x 630)

10. CATALYSTS FOR THE SECOND STAGE OF HYDROCARBON STEAM REFORMING

Due to the difference in temperature in the course of conducting low-and-high temperature hydrocarbon conversion processes, different requirements are imposed upon their catalysts. At high temperatures, ensuring up to 70 % of hydrogen production in the products of steam reforming, there is no need for high catalytic activity. The rate of high-temperature chemical reactions is sufficiently high, and dispersity of the active component of catalyst (Ni) should not be very thin. Otherwise, sintering [спекание] of metallic Ni occurs due to high temperatures. For industrial catalysts of high-temperature conversion, nickel surface usually makes 0.5-1 m²/g but then more strict requirements are placed on catalysts' mechanical strength in order to resist high temperature effects. We have developed technique for high-velocity plasma spraying of catalytic material ensuring production of various compositions of supporters and catalysts with different microstructures and surface morphology meeting specific process conditions.

10.1 METHOD OF HIGH-VELOCITY PLASMA SPRAYING

The manufacturing techniques for catalyst supporter of the second conversion stage lies in deposition by spraying on metallic strip (primary supporter or substratum) with linear velocity 100-150 m/min of powder composition consisting of the following (percent by mass): aluminum – 3-5; chromium oxide – 2-5; tungsten oxide – 0.8-1.2; cerium, lanthanum, neodymium oxides in the aggregate – 1.8 -2.2; aluminum hydroxide – all the rest.

Deposition of powder composition is done on the belt drum, 70-90mm away from metallic supporter; thickness of catalytically active layer is set at 30-70 μm. Schematic of the installation is shown in Fig.8. Then two-stage thermal treatment of the samples takes place.

High-velocity plasma spraying of powder composition onto initial metallic supporter ensures diffusion (under non-equilibrium state) of aluminum, aluminum hydroxide, compounds of transition metals and rare-earth elements in supporter material, as well as the highest adhesion strength of the deposited material and substratum.

In the sprayed powder composition, aluminum acts as binder metal; its percentage directly impacts mass, thickness of the sprayed layer and its porosity. At aluminum content $< 3\%$ by mass, the thickness of the sprayed layer does not exceed 10-15 μm at satisfactory layer porosity. At aluminum content $> 5\%$ by mass, due to the excessive aluminum content, low layer porosity and, consequently, its low catalytic activity is observed.

In the sprayed powder composition, aluminum hydroxide is a pore-formative component. At aluminum hydroxide content $< 86\%$ by mass (at aluminum content from 3 - 5 % by mass), low porosity is observed and, consequently, low layer catalytic activity due to insufficient content of $\text{Al}(\text{OH})_3$ in powder composition. At aluminum hydroxide content $> 92\%$ by mass, increased consumption of powder composition is observed; thickness of sprayed layer does not exceed 10-15 μm due to the shift of $\text{Al}/\text{Al}(\text{OH})_3$ ratio to aluminum hydroxide increase side.

At chromium oxide content $< 2\%$ by mass (chromium acts as a promoter in the given powder composition), low catalytic activity is observed. At chromium oxide content $> 5\%$, the fill-up of porous surface with chromium is observed and, as a consequence, decrease of the specific surface of the catalytic layer. The analogous conclusion can be reached in relation to the content limits of tungsten in the powder composition.

For thermostabilization of gamma aluminum oxide, oxide mixture of rare earth elements (cerium, lanthanum, neodymium) has been introduced into powder composition. At this oxide mixture content $< 1.8\%$ by mass, under operation temperature 700 – 900 $^{\circ}\text{C}$, decrease of the coat specific surface is observed, as well as content increase of alpha modification of aluminum oxide.

At the oxide mixture content of cerium, lanthanum, neodymium $> 2.2\%$ in the aggregate, low catalytic activity and coat specific surface is observed caused by excessive content of high-melting components filling-up active centers.

The developed spraying techniques allow powder composition supply through the two and more self-contained devices enabling powder feed to various temperature zones of plasma jet and creation of functionally-gradient coats.

Kinetics investigations have shown that aluminum hydroxide, due to significant content of crystal water in the structure, is an unstable compound which decomposes when being heated into compounds corresponding to the various degree of aluminum oxide hydration. Delivery of the residual quantity of aluminum hydroxide (in the form of gibbsite and bemite) to metallic supporter at plasma spraying was the basic condition for technical result securing.

Top extend a surface, deposited by spraying layers are subjected to the two-stage thermal treatment in the temperature range from 350 to 700 $^{\circ}\text{C}$ wherein decomposition of residual aluminum hydroxide occurs along with oxidation of aluminum to $\gamma\text{-Al}_2\text{O}_3$ with porous structure formation (Table14):

1st stage corresponds to the temperature range 350 - 400 $^{\circ}\text{C}$ and 0.5h residence time. Isolation of the first two moles of water occurs at that; residual hydroxide (gibbsite) rapidly transits to fine-dispersed phase which in itself is mixture of aluminum and bemite oxides.

2nd stage corresponds to the temperature interval of 550 - 700 $^{\circ}\text{C}$ and residence time of 1.5 – 2.0 h Bemite loses one more mole of water at that and turns into gamma aluminum oxide ($\gamma\text{-Al}_2\text{O}_3$) needed to secure porous layer.

Time of thermal treatment corresponds to the deepest decomposition of gibbsite. Otherwise intermediate phases are formed promoting formation of alpha aluminum oxide, characterized by low porosity of the layer as opposed to the gamma phase.

Two factors make for the process of aluminum hydroxide oxidation and aluminum gamma-oxide formation: crystallization center of aluminum gamma-oxide formation and punctual sustenance of heating temperature and time of delay. It leads to more complete quantitative formation of aluminum gamma-oxide needed for provision of high catalytic activity of the deposited layer.

Table 14**Parameters of catalytic supporter depending on thermal treatment mode**

Annealing temperature, °C	Annealing time, h	Phase composition of coat, % to mass	Specific surface, m ² /g
350	0.5	Gibbsite >80, bemitite 1-3, aluminum oxide of gamma modification <15, aluminum oxide of alpha modification <3; aluminum < 5	8
400	0.5	Gibbsite >10, bemitite 6-9, aluminum oxide of gamma modification < 50, aluminum oxide of alpha modification < 3; aluminum < 3	18
550	2.0	Gibbsite <1, bemitite 3-5, aluminum oxide of gamma modification > 80, aluminum oxide of alpha modification < 5; aluminum < 1	42
700	1.5	Gibbsite, bemitite are absent, aluminum oxide of gamma modification > 80, aluminum oxide of alpha modification < 8; aluminum is absent	38

As a result of plasma spraying of powder composition with linear velocity < 100 m/min, they obtain a coat with insufficient mass and thickness of the sprayed layer and as a consequence decrease of catalytic activity at the durable tests is observed. As a result of plasma spraying of powder composition with linear velocity < 150 m/min they obtain a coat with the layer thickness > 70 μm that is characterized by low adhesive strength resulting in crack formation and material peeling.

When positioning plasmatron at < 70 mm from the substratum, high temperature is observed in the spraying zone and during spraying process aluminum particles melt; as a consequence, the coat has low porosity and low catalytic activity. If plasmatron is located at the distance > 90 mm from substratum, low temperature is observed in the spraying zone; therefore thickness of the sprayed-on layer does not exceed 10 – 15 μm.

When spraying a coat < 30 μm thick, decrease of catalytic activity is observed due to insufficient quantity of the material on the supporter' surface. If the layer's thickness is > 70 μm, low adhesive strength of the layer promoting crack formation and material peeling is observed.

To conduct further investigations, three-compound powder composition has been prepared (Table 15). Deposition of powder composition on the samples of metallic supporter with linear velocities 100 and 150 m/min and using two dosers, has been performed on the experimental setup of plasma spraying of "Plasma-1" type using air plasmatrons. Samples are made of steel (X15IO5 grade) 50 μm thick; their dimension is 100x100 mm. The samples are mounted and fastened on the belt drum.

Table 15**Compounds of powder composition**

Content of powder composition compounds, % by mass					
No	Aluminum	Oxides of cerium, lanthanum, neodymium (in the aggregate)	Chromium oxide	Tungsten oxide	Aluminum hydroxide
1	5.0	1.8	2.0	1.2	90.0
2	4.0	2.0	3.6	1.0	89.4
3	3.0	2.2	5.0	0.8	89.0

After that the samples were subjected to the two-stage thermal treatment in muffle furnace in two variations:

- at 350° C and 0.5h residence time with subsequent heating up to 550° C and 2h residence time ;
- at 400° C and 0.5h residence time with subsequent heating up to 700° C and 1.5h residence time.

Deposition of the active component *Ni* on the produced supporter was exercised in two ways: by widely known method of chemical impregnation and by evaporative condensation. With the first method, the supporter was impregnated with nickel nitrate solution $\text{Ni}(\text{NO}_3)_2$ [450-500 g/l], then dried and calcinated at 400-450° C during 3 hours in order to decompose nickel salt and to form nickel oxide. With the second method, Ni deposition was exercised in the vacuum installation of ion-plasma spraying. Essentially, the method of ion-plasma spraying is evaporation of the target atoms from nickel (Fig.24) under impact of plasma flow and their subsequent directed deposition on the supporter. Prior to the sample activity test, the catalyst is being reduced in hydrogen flow during 4 hours at 600° C.

10.2 METHOD OF COLD GASDYNAMIC SPRAYING

Of the most interest for the processes of hydrocarbon fuel conversion in the temperature range 600 - 1000°C is application of catalysts based on nickel and aluminum. The established qualitative-and-quantitative dependence of material properties on their structure points up to the good prospects of materials with amorphous and microcrystalline structure to ensure production of highly efficient catalysts.

The main objective of this stage of the work is application of technology of the "cold" gasdynamic spraying in order to produce functionally-gradient catalytic coat based on microcrystalline material.

Apart from this complicated technological task it was imperative to solve three material science problems, namely:

- selection of substrate material (for primary catalyst carrier);
- selection of catalyst material;
- selection of material that allows development of free catalyst surface under thermal treatment

Apart from nickel and aluminum, additional components exerting positive effect upon coat characteristics have been incorporated into catalytically active layer. We used, as the additional components, chromium oxides which are the strongest oxidants; tungsten oxide ensuring efficient oxygen sorption; oxide mixture of rare-earth elements widely used in the capacity of thermal stabilizers; gamma alumina characterized by large specific surface.

Efficient catalyst operation within specified lifetime is conditioned to a great extent by substrate's serviceability at the running catalytic reaction temperatures. Application of carriers based on various steel grades enhances design capabilities for catalytic reactors of the planar and frame types. The exacting requirement to a substrate material is the provision of high adhesion to catalyst applied by CGDS and preservation of adhesion strength during total time of catalytic element operation.

As a rule, temperature range of catalyst operation depending on the reactor type is 600 - 1300°C which makes the quest for unification of substrate material non-expedient. It is appropriate to use low-alloy steels for the operating temperatures (600-900°C), while extreme working conditions (900-1300°C) call for application of high-alloy steels based on refractory metals.

As substrate materials for experimental production of catalyst samples we have selected the following:

- ferritic steel of X15IO5 grade in the form of a tape 50 μm thick;
- austenitic steel X18H10T grade in the form of a tape 200 μm thick.

For the spraying purposes we have selected a promising composition on the strength of the following prerequisites:

- catalytically active components Ni and Al in the ratio close to the compositions of intermetallic compounds $NiAl_3$ and Ni_2Al_3 ;
- thermostabilizing additives Cr, Mo, REE (rare-earth elements);
- materials-plasticizers Al and Zn for provision of maximum adhesion-cohesion characteristics;
- pore-forming component $Al(OH)_3$ featuring in the process of heating a dissociation reaction $Al(OH)_3 \rightarrow \gamma(Al_2O_3) + H_2O$

The first pilot experiments have been conducted at various Ni /Al ratio in the composition of the sprayed mixture (Table 1). The coating has been sprayed on substrata (made of X15IO5 and X20H10T grade steels) placed at 20-50 mm distance from the nozzle, by CGDS method at the rate of 700 m/s.

Table 16

Dependence of relationship between coating components on chemical composition of mixture sprayed on metallic carrier

№	Steel grade of metallic carrier	Composition of sprayed mixture	Initial component relationship in Ni/Al mixture	Results of chemical analysis	Component relationship in Ni/Al coating (found)	Found
						Determined
1	X15IO5	40%Ni; 60%Al	0,67	Al-70,3; Ni-27,2 Fe-1,0; Zn-1,3	0,39	Ni=0,68 Al=1,17
2	X20H10T	40%Ni; 60%Al	0,67	Al-70,9; Ni-28,0 Fe-0,9	0,39	Ni=0,7 Al=1,18
3	X15IO5	60%Ni; 40%Al	1,5	Al-60,4; Ni-37,7 Fe-1,2; Zn-0,5	0,62	Ni=0,63 Al=1,51
4	X20H10T	60%Ni; 40%Al	1,5	Al-61,5; Ni-38,1 Fe-0,2	0,62	Ni=0,2 Al=1,54
5	X15IO5	40%Ni; 55%Al 5%Cr	0,73	Al-57,1; Ni-40,0 Fe-0,5; Cr-2,2	0,70	Ni=1,0 Al=1,04 Cr=0,42
6	X20H10T	40%Ni; 55%Al 5%Cr	0,73	Al-54,7; Ni-42,7 Fe-0,9; Cr-1,4 Zn-0,2	0,78	Ni=1,07 Al=0,99 Cr=0,28
7	X15IO5	43%Ni; 55%Al 2%Cr	0,78	Al-65,5; Ni-32,7 Fe-0,6; Cr-1,1	0,50	Ni=0,76 Al=1,19 Cr=0,55
8	X20H10T	43%Ni; 55%Al 2%Cr	0,78	Al-65,1; Ni-33,3 Fe-0,8; Cr-0,6	0,51	Ni=0,77 Al=1,18 Cr=0,3

On the results obtained through chemical analysis of the coating (See Table 16) the following conclusions can be arrived at:

1. The relationship between nickel and aluminum in the coating is specified by composition of the initial powder compound and does not depend on the metallic carrier material grade (found relationship between Ni and Al in the coating is practically the same for each substrate type);

2. For the purpose of further investigations, the substrate made of X15IO5 steel and 50 μm thick has been selected as the most suitable one for research aimed at determination of specific surface and catalytic activity of the material being obtained;
3. For the consequent spraying as the principal composition, the powder mixture has been chosen containing 40 % Ni and 60 % Al. It was dictated by the following considerations:
 - under given relationship of powder composition components, the experiment resulted in the fullest component carriage to the substrate;
 - physical-mechanical properties of aluminum, particularly its high plasticity, stipulate efficiency of its usage as a binding metal when spraying.
 - in catalytic coating practice, aluminum is frequently selected as a material to be sacrificed at surface leaching and development, therefore some of its extra amount is usually introduced into the initial material.

The next stage of work dealt with investigation of vacuum thermal treatment effect on coat characteristics. The objective of such operation was conducting interdiffusion of coat components in order to form solid solution and intermetallic compounds along with provision of optimal conditions for the formation of porous structure based on gamma alumina.

Samples of catalytic coat were subjected to thermal treatment in a vacuum oven at 600° C, residual vacuum $4.0 \cdot 10^{-3}$ Pa within two hours. The coat specific surface size increased after thermal treatment by 2.3 times as compared to its initial state. According to X-ray studies, the main reason was rearrangement of the structure associated with formation of intermetallic compounds of the NiAl_3 and Ni_2Al_3 type (Fig.48).

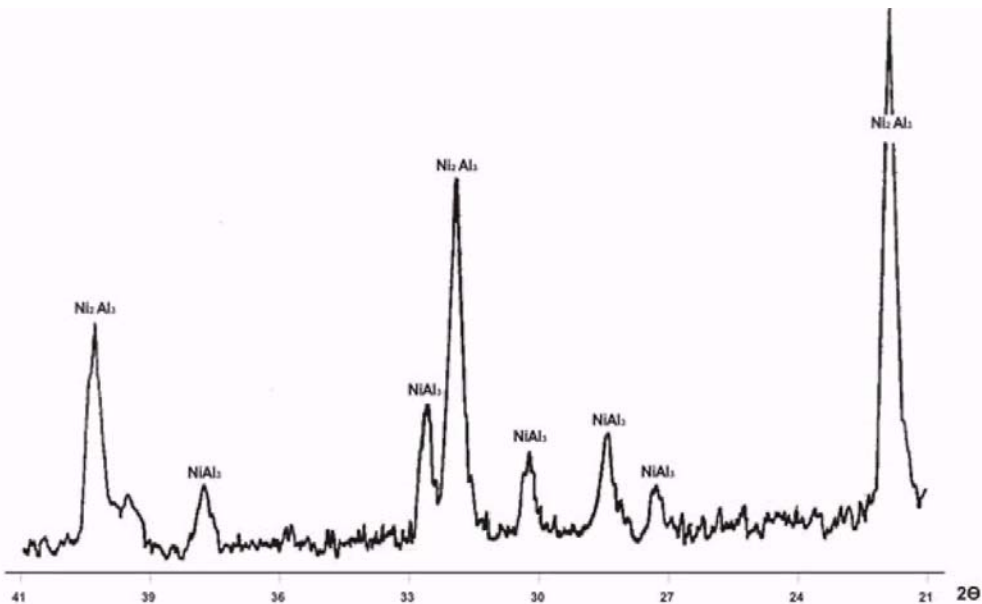

Fig.48 X-ray photograph of a coat

The results of electron microscope investigations presented in **Fig.49** have also indicated noticeable increase in catalytic coat surface.

Table 17

Catalytic coat basic characteristics			
Coat composition	Coat characteristics		
	Temperature stability °C	Adhesion kg/mm ²	Specific surface m ² /g
40% Ni; 60% Al	720-750	1,5-2,5	0,5-1,3
36% Ni; 56% Al; 4% Cr; 2% Mo; 2% Σ P3Э	970-990	2-3	3,4-4,7
36% Ni; 48% Al; 2% Cr; 2% Mo; 2% Σ P3Э; 10% Zn	880-910	5-7	4,1-6,3
32% Ni; 42% Al; 5% Cr; 2% Mo; 2% Σ P3Э; 2% Zn; 15% Al(OH) ₃	987-1020	5-6	5,4-7,5

To obtain kinetic data and computation of rate constant for reaction of methane-vapor interaction, catalyst samples have been synthesized as per above CGDS technique. Presented in **Fig. 50** are the research results of catalytic activity rating (by methane residual) in relation to gas linear velocity at various volume velocities and conversion temperature $t = 800^\circ \text{C}$. At this temperature the activity obtained comes close to equilibrium one, which is indicative of the good quality of new catalyst samples.

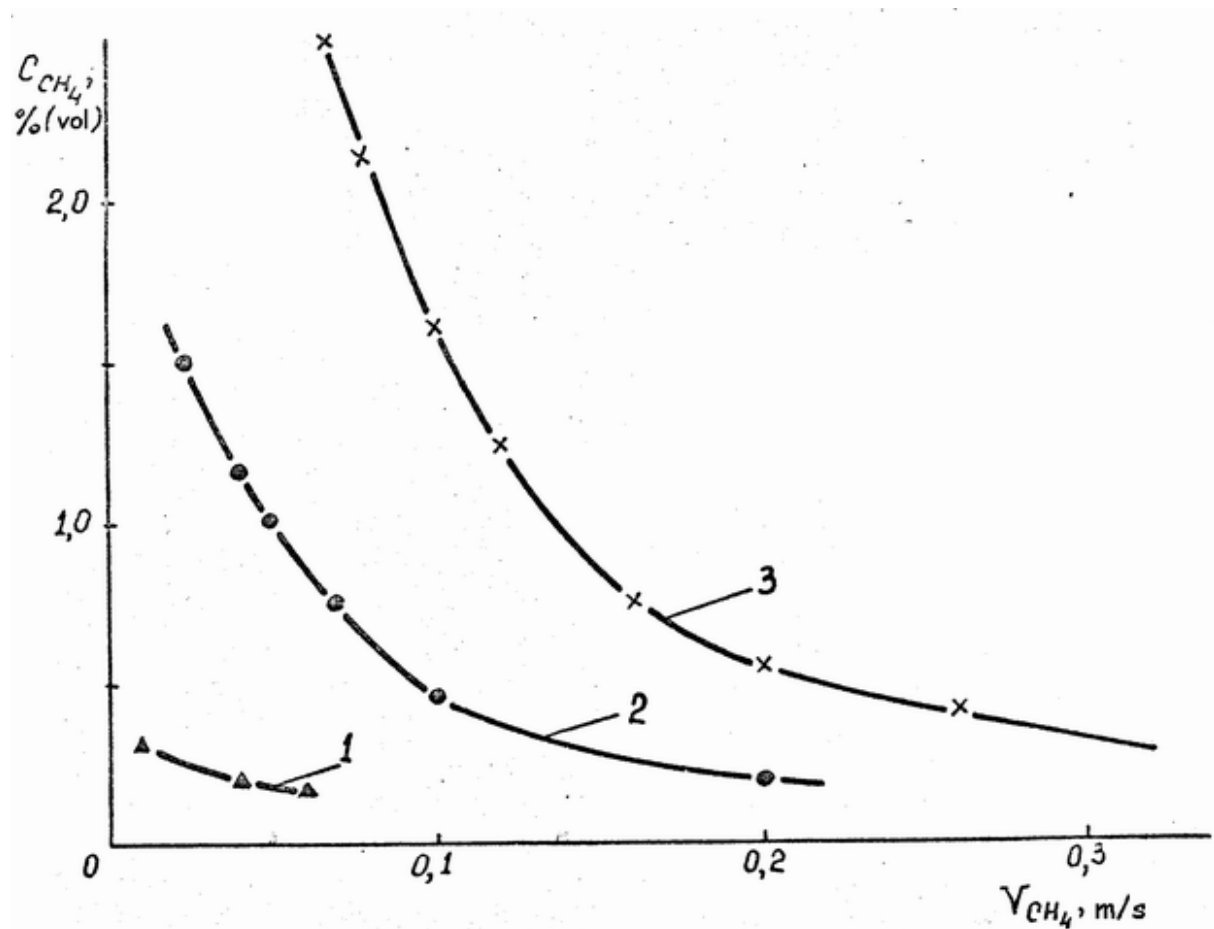

Fig.50 Catalytic activity rating (by methane residual) in relation to gas linear velocity at various volume velocities and conversion temperature $t = 800^\circ \text{C}$.

Volume velocity V_{CH_4} , h^{-1} : 1 – 1000; 2 – 6000; 3 – 10000.

11. APPLICATION OF THE CGDS METHOD FOR MANUFACTURE OF THERMOCHEMICAL REACTORS AND OTHER HEAT-EXCHANGE DEVICES

At the present time, when producing thin-wall cell structures (such as thermochemical reactors and heat exchangers), the most pressing problem is replacement of existing expensive and labor-consuming types of welding with more economical and efficient soldering technology. Usage of amorphous solders ensuring active diffusion processes at the expense of non-equilibrium composition seems the most promising solution. Therefore soldering with amorphous solders is called activated one. Characteristic feature of the activated soldering is formation of a solid transitional layer of a diffusion nature between the elements to be joined; it holds true even when consolidating materials with different chemical-physical properties (such as titanium-steel, copper-steel, metal-ceramics).

The undisputed advantages of activated amorphous soldering are as follows:

- Possibility to solder the thin-wall structures from heterogeneous materials;
- Split-hair connection accuracy of the mating elements;
- Provision of vacuum density, high strength, and plasticity of the connections at the minimum width of the soldered seam;
- Durable preservation of high mechanical strength of the soldered composition;
- Increase of metal and solder utilization factor (from 0.15 to 0.85);
- Higher efficiency of the process (by two-three times) as compared to welding;
- High corrosion resistance of the materials with amorphous structure and tendency to passivation under external action of the various aggressive media;
- Achievement of strength close to the strength of the material soldered.

It should be noted, that during soldering complicated interaction processes occur simultaneously in the systems: base metal-solder-air or base metal-controlled gas medium-solder; equilibrium state, as a rule, is not achieved at that. Therefore, the processes occurring at the formation of the soldered connection, including crystallization, are non-equilibrium ones. It is common that under non-equilibrium crystallization the process of composition leveling off is being partly suppressed not only in the solid phase but in the liquid phase, too. As is well known, "non-equilibrium state" of alloy crystallization leads to liquation, which in turn, causes emergence in the seam of the low-melting, usually eutectic, component with higher brittleness and lower strength. Usage of amorphous materials as solders eliminates the possibility of eutectic component formation, i.e. mechanically not strong component in the form of independent phase in the soldered seam.

Existing procedures of amorphous material production make it possible to have them in the form of a tape 1-200 mm wide and 20-50 μm thick, powder of fraction from 20 to 300 μm and fibers with diameters of 5 μm and larger. The above geometrical dimensions are very convenient for assembly and practical realization of activated soldering process as applied to many concrete structures. Apart from that, the tape amorphous materials production procedure by quick hardening methods allows expansion of borders of solid solutions, enhancement of alloys technological plasticity, and reduction of their production costs. Application of quick hardening procedure to obtain solder tapes makes also possible increase of soldered seam uniformity.

Due to oversaturation of solid solutions, absence of long-range order in atom arrangement, amorphous solders have a wider range of chemical element contents. They are characterized by enhanced surface chemical activity as compared to the appropriate crystalline materials culminating in higher initial velocities of dissolution or diffusion. As a rule, actively diffusing components are introduced into the solder composition. This ensures its high adhesive properties (wettability, spreading), narrow range of melting temperatures, and high strength of soldered joint.

A broad spectrum of possible compositions of amorphous alloys allows their application in a wide temperature range – from steel and refractory ceramics high melting points down to semi-conductors and microelectronic details low melting points.

Most of the heat exchange major components ensuring maximum thermo-physical characteristics have, as a rule, an elaborate design. In some cases due to inability to secure tape of amorphous solder in a piece, research engineers come up against the problem of structure soldering in one complete cycle. In this situation the best way to be followed is application of powder composition solders on the soldering surface in a variety of methods. In so doing, it is necessary to determine the amount of solder required for realization of activated soldering. The most promising method of solder dosed application, in our opinion, is application of “cold” gas - dynamic spraying technique.

Using the totality of previous experience we have developed the schematic diagram of activated soldering with amorphous solders. (Fig.51)

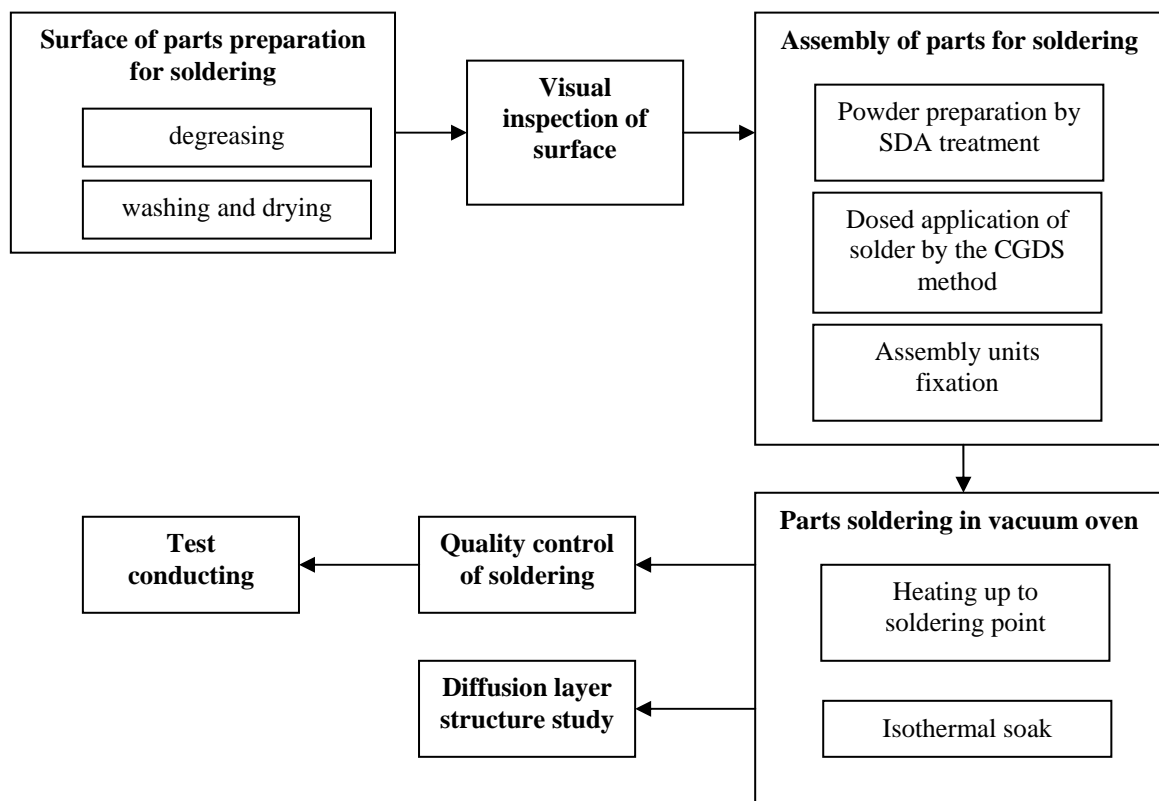

Fig.51 Schematic diagram of activated soldering by the use of amorphous solders

It should be pointed out that in the above schematic, dosed solder deposition on the products takes place and from the tapes of amorphous solders obtained powder compositions are prepared as per our developed technology of shock disintegrating-activating treatment (SDA) with no change in chemical composition and with preservation of the amorphous structure. Then the procedure of dosed application of powder alloys onto soldering surfaces occurs with the help of CGDS following which the structure is assembled and placed in the oven to realize soldering process. One of the features of activated soldering as per developed scheme is a resulting seal with high mechanical and corrosion-proof properties when operating under extreme conditions. When working out the technology, it was established that to achieve this we need to use dosed solder application in the amounts which would completely react with the material of the products soldered in the process of isothermal soak. The required batching of solders is ensured at the expense of CGDS technology application.

It is not infrequent that to manufacture heat exchanging devices they use titanium and its alloys. To solder these materials, different solders are used, particularly ones of Ti-Zr-Cu-Ni system. In the course of the work we have obtained chemical compositions of tape solders (% by mass):

Ti-base; Zr – 10-25; Ni – 7-14; Cu – 15-45; ($T_{\text{melt}} = 785\text{-}850^{\circ}\text{C}$).

As proved by practice, optimal composition for achievement of reproductive results is (per cent by mass): Ti - 61; Zr -10; Ni – 14; Cu – 15 ($T_{\text{melt}} = 785^{\circ}\text{C}$)

From this alloy amorphous tape 15 mm wide and 20 μm thick has been manufactured by melt spinning method.

To produce disperse amorphous powders we resorted to SDA treatment of the initial amorphous tape. The general concept of SDA treatment is based on momentary high-energy impact on powder, granular, or fiber material in special rotor disintegrators. As a result of such impact, high-velocity micro-metallurgical processes run in the material leading to reciprocal diffusion of the treated metals, formation of solid solutions, inter-metallic compounds, phase and structural transformations.

Large material particles under treatment are fed from the dosing devices to actuating chamber wherein with the help of toothed rotors rotating towards each other at the rate of up to 22000 rpm (revolutions per minute) they form counter-directional particle flows. At particles collision with intensity of up to 450g their simultaneous crushing to several microns occurs and chemical compounds are formed, too. At the instant of collision, accumulated kinetic energy turns into the inner one ensuring particle shift into molten state. Subsequent interaction of the fused particle with cold rotors and body of the activating chamber provides for high-speed cooling down, as a result of which the non-equilibrium material structure obtained is being fixed. Adjustment of treatment velocity and initial powder composition allows production of the materials with required chemical and phase compositions.

Analysis of X-ray patterns obtained before and after SDA powder treatment shows that this method does not lead to the change of structure components of the amorphous alloy solder (Fig.52).

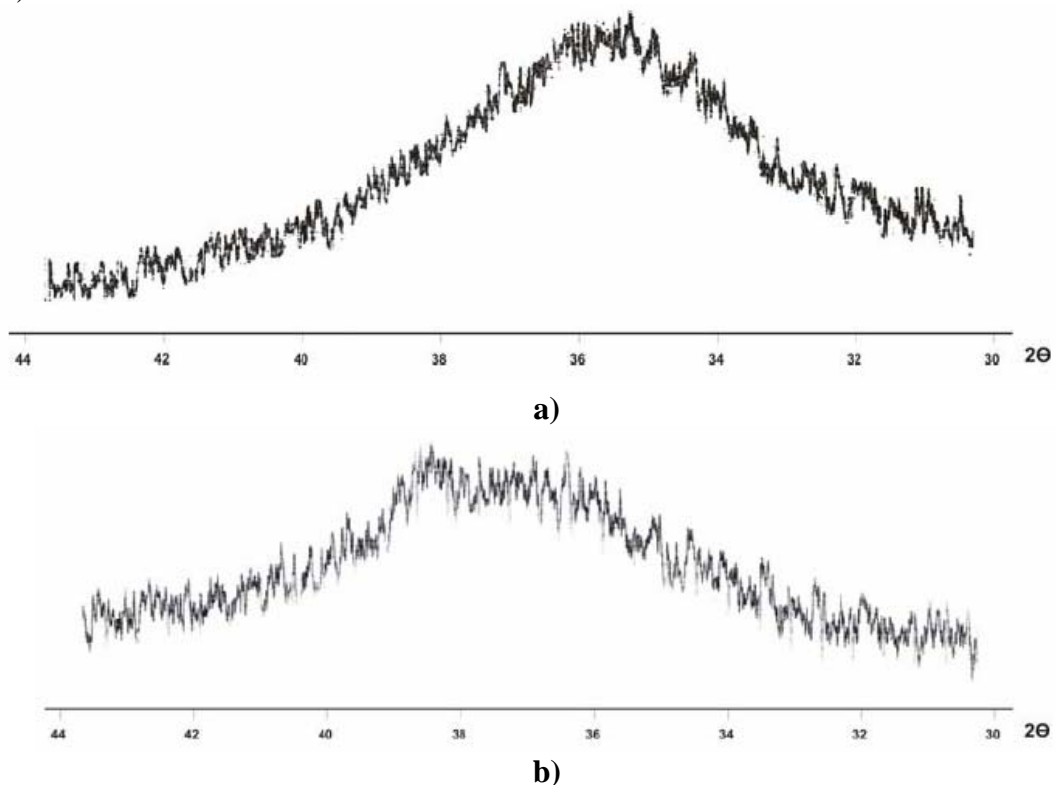

Fig.52 “X-ray patterns of the material from alloy of the system Ti-Zr-Ni-Cu in the initial state before (a) and after (b) crushing”

Production of the powder amorphous solder of the required fraction composition is followed by its dosed deposition on the pieces being soldered by CGDS method.

The procedure of amorphous solder layers deposition by CGDS method 50 – 100 μm thick has been developed in the course of the work. Only this thickness guarantees full “solution” of solder components in the base material as a result of technological process of activated soldering. Optimal size of particles of the amorphous powder used was also determined. It makes $\leq 63 \mu\text{m}$. The developed technology of activated soldering with amorphous solders allows production of the seal possessing required physical-and-mechanical properties ($\sigma_b \geq 0.8 \sigma_b$ of base metal). It ensures, as confirmed by tests, high mechanical breaking strength (the breakdown occurs on base metal, i.e. ultimate strength of the soldered seam exceeds ultimate strength of the material being soldered), high corrosion resistance of the soldered assembly (corrosion rate does not exceed 0.003 mm per year), production of vacuum-tight joint (up to 10^{-9} mbar·l/s).

Metallographic examinations conducted (Fig.53a) shown that activated soldering technique at 805°C and 15min isothermal soak ensures creation of the solution-diffusion seal and absence of solder in the form of independent phase. This is also supported by X-ray spectrum analysis (Fig.53b).



a)

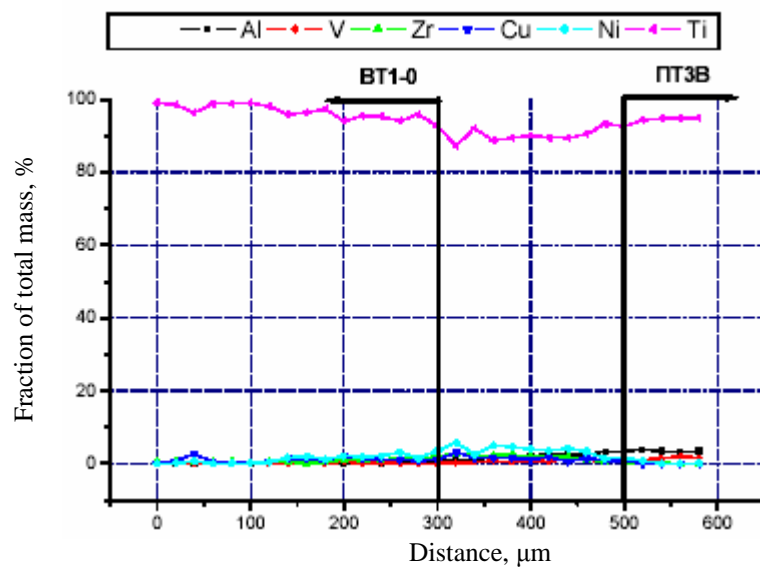

b)

**Fig.53: a – joint Ti (BT1-0 on the left, IIT3-on the right)
b –distribution of elements in soldered seam**

The above technological scheme was successfully tested, as applied to consolidation of elements of heat-exchanging module of cell structure shown in **Fig.54**

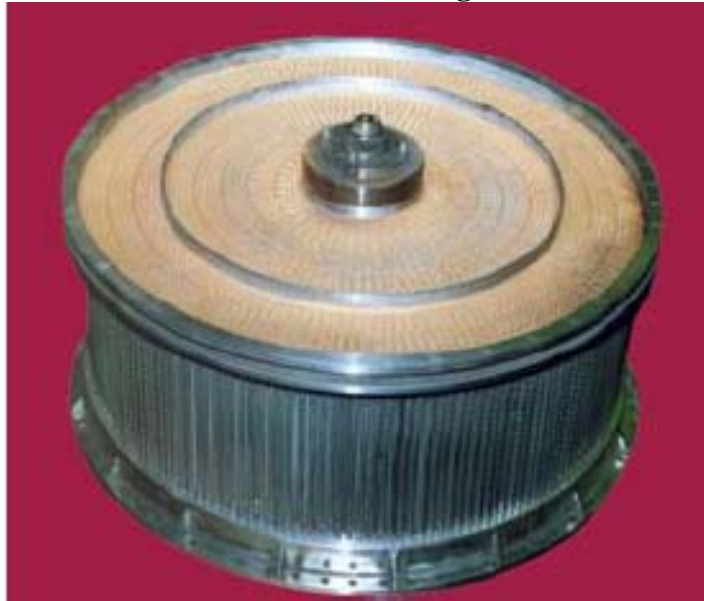

Fig.54 Heat-exchanging module of cell structure

CONCLUSION

Through the application of the results obtained in the course of investigations we can draw the following inferences:

1. Analysis of the present state of developments in the sphere of thermochemical conversion of hydrocarbon fuels and waste-heat recovery made it apparent that performance of wide complex of works related to elaboration of chemical heat regeneration technology is badly needed. The following exploring areas seem to be most encouraging: choice of endothermic processes, investigation of engine thermodynamic cycles using chemical heat regeneration and the processes in the combustion chambers on the products of conversion; investigation of close energetics-ecology relationship; usage of new technologies and materials for the creation of thermochemical reactors as components of energy installations; minimization of coke-formation processes at fuel conversion.
2. Catalytic reactor in the process of its functioning can be subjected to synergetic impact of combined factors, such as temperature, pressure, cyclic mechanical and thermal stresses, reaction mixture composition, etc. The potentialities of conventional materials with equilibrium structure in provision of the stable catalyst activity and coke deposit prevention have practically been exhausted. To produce competitive items it seems most expedient to use gradient-functional materials on metallic base with amorphous and microcrystalline structure. They allow creation of a new generation of catalysts featuring given complex of physico-mechanical and operating characteristics. New catalysts and new techniques of their production are needed for the solution of large-scale industrial, transport and environmental problems.
3. The development of thermochemical reactors for propulsion and power systems operating on hydrogenous fuels is possible only with the usage of new porous catalytic coating technique accompanied by smooth variation of chemical composition, structure, physical and mechanical properties thickness-wise of the item. Of a practical interest is

investigation of possibility to create such coatings using modified technologies of super-sonic plasma, cold dynamic, magnetron and ion-plasma spraying, as well as chemical, sol-gel and slip-casting technologies.

4. The developed plasma spraying technique for catalyst supporter implies that powder mixture prepared beforehand is being transmitted by high-temperature plasma jet onto metallic heat-resistant band. At the same time, aluminum hydrate – gibbsite $\text{Al}(\text{OH})_3$, undergoes dehydration under temperature impact, going first to bemite AlOOH , and then to oxide Al_2O_3 . Successive decomposition of aluminum hydroxides ensures high surface area. Aluminum is deposited along with aluminum hydroxide in order to provide required adhesion to substrate XI5IO5 and is kind of a “frame” for aluminum hydroxide. The function of additives in powder composition is to ensure thermal stabilization of the supporter’s surface and create transport pores for the components of reaction access to the active catalysis centers.
5. The method of “cold” gasdynamic spraying for application of porous catalytic coatings has been modified. It has the following unquestionable advantages: the particles are being transferred in a “cold” state with transfer rate $\geq 2\text{M}$; their heating is caused by transformation of kinetic energy into thermal energy in the process of interaction with the obstacle, that is, at the coating formation directly; possibility to obtain coatings absolutely adequate in composition to the powder being sprayed; possibility to use composite powders with permanent and adjustable composition by coat thickness; absence of noticeable thermal effect on substrate material; relative safety, economical efficiency and simplicity of the process.
6. Produced by CGDS technique were catalyst samples having in their composition the following: catalytically active components Ni and Al in the proportion close to compositions of intermetallic compounds NiAl_3 and Ni_2Al_3 ; thermostabilizing additives Cr, Mo, REE (rare-earth elements); materials-plasticizers Al and Zn for provision of maximum adhesive-cohesive characteristics; pore-forming component $\text{Al}(\text{OH})_3$, characterized (in the process of heating) by reaction of dissociation $\text{Al}(\text{OH})_3 \xrightarrow{\text{temperature}} \gamma - \text{Al}_2\text{O}_3 + \text{H}_2\text{O}$. Principal physico-mechanical and structural characteristics of coatings with thermal stabilization up to 1000°C , adhesion $5 - 7 \text{ kg/mm}^2$ and specific surface up to $10\text{m}^2/\text{g}$ have been investigated.
7. Catalytic activity of catalyst samples for low-temperature and high-temperature hydrocarbon conversion has been investigated, too. The results of the above investigations indicate that the developed techniques of catalytic coatings can find their application with the systems of thermal protection and fuel conversion in propulsion systems and power plants.