

**A NEW PERSPECTIVE ON USE OF THE CRITICAL DECISION
METHOD WITH INTELLIGENCE ANALYSTS**

Susan G. Hutchins,¹ Peter L. Pirolli,² and Stuart K. Card²

¹Naval Postgraduate School
Information Science Department
589 Dyer Road, Code IS/Hs
Monterey, CA 93943-5000
shutchins@nps.navy.mil

² Palo Alto Research Center
User Interface Research Group
3333 Coyote Hill Road
Palo Alto, CA 94304
pirolli@parc.xerox.com
card@parc.xerox.com

Keywords: Cognitive Task Analysis, Intelligence Analyst, Critical Decision Method

Report Documentation Page

Form Approved
OMB No. 0704-0188

Public reporting burden for the collection of information is estimated to average 1 hour per response, including the time for reviewing instructions, searching existing data sources, gathering and maintaining the data needed, and completing and reviewing the collection of information. Send comments regarding this burden estimate or any other aspect of this collection of information, including suggestions for reducing this burden, to Washington Headquarters Services, Directorate for Information Operations and Reports, 1215 Jefferson Davis Highway, Suite 1204, Arlington VA 22202-4302. Respondents should be aware that notwithstanding any other provision of law, no person shall be subject to a penalty for failing to comply with a collection of information if it does not display a currently valid OMB control number.

1. REPORT DATE JUN 2004		2. REPORT TYPE		3. DATES COVERED 00-00-2004 to 00-00-2004	
4. TITLE AND SUBTITLE A New Perspective on Use of the Critical Decision Method with Intelligence Analysts				5a. CONTRACT NUMBER	
				5b. GRANT NUMBER	
				5c. PROGRAM ELEMENT NUMBER	
6. AUTHOR(S)				5d. PROJECT NUMBER	
				5e. TASK NUMBER	
				5f. WORK UNIT NUMBER	
7. PERFORMING ORGANIZATION NAME(S) AND ADDRESS(ES) Naval Postgraduate School, Information Science Department, 589 Dyer Road, Monterey, CA, 93943-5000				8. PERFORMING ORGANIZATION REPORT NUMBER	
9. SPONSORING/MONITORING AGENCY NAME(S) AND ADDRESS(ES)				10. SPONSOR/MONITOR'S ACRONYM(S)	
				11. SPONSOR/MONITOR'S REPORT NUMBER(S)	
12. DISTRIBUTION/AVAILABILITY STATEMENT Approved for public release; distribution unlimited					
13. SUPPLEMENTARY NOTES The original document contains color images.					
14. ABSTRACT					
15. SUBJECT TERMS					
16. SECURITY CLASSIFICATION OF:			17. LIMITATION OF ABSTRACT	18. NUMBER OF PAGES 35	19a. NAME OF RESPONSIBLE PERSON
a. REPORT unclassified	b. ABSTRACT unclassified	c. THIS PAGE unclassified			

A New Perspective on Use of the Critical Decision Method with Intelligence Analysts

Susan G. Hutchins

Naval Postgraduate School
Information Science Department
589 Dyer Road, Code IS/Hs
Monterey, CA 93943-5000
shutchins@nps.navy.mil

Peter L. Pirolli and Stuart K. Card

Palo Alto Research Center
User Interface Research Group
3333 Coyote Hill Road
Palo Alto, CA 94304
pirolli@parc.xerox.com
card@parc.xerox.com

Abstract

Intelligence analysts engage in information seeking, evaluation, prediction, and reporting behavior in an extremely information-intensive work environment. A Cognitive Task Analysis (CTA) was conducted on intelligence analysts to capture data that will provide input to support development of a computational model of the analyst's processes and analytic strategies. A hybrid method was used to conduct the CTA, including a modified version of the critical decision method. Participants were asked to describe an example of a critical analysis assignment where they had to collect, analyze, and produce a report on intelligence of a strategic nature. Procedures used to conduct the CTA are described in this paper along with initial results. Several factors contribute to making the analyst's task challenging: *(i)* time pressure, *(ii)* a high cognitive workload, and *(iii)* difficult human judgments. Human judgments are involved in considering the plausibility of information, deciding what information to trust, and determining how much weight to place on specific pieces of data. Intelligence analysis involves a complex process of assessing the reliability of information from a wide variety of sources and combining seemingly unrelated events. This problem is challenging because it involves aspects of data mining, data correlation and human judgment.

INTRODUCTION

Intelligence analysis involves a complex process of assessing the reliability of information from a wide variety of sources and combining seemingly unrelated events. Sorting through huge amounts of information, produced from a variety of sources (i.e., human, electronic, open source, measures and signals intelligence, and imagery), and

represented in many different forms (e.g., written and oral reports, satellite images, tables of numeric data) to construct an accurate depiction of a situation and make predictions regarding the situation presents a difficult problem for the intelligence analyst (IA). Products of this information foraging and analysis are used by senior decision-makers to make high-stakes decisions. The problem faced by intelligence analysts is challenging because it involves aspects of data mining, data correlation and human judgment (NIMD, 2002).

Intelligence analysis is a dynamic and highly iterative process that involves viewing the information from different viewpoints in order to examine competing hypotheses or develop an understanding of a complex issue. The critical role of the human is in adding "value" to original inputs by integrating disparate information and providing an interpretation (Krizen, 1999). This integration and interpretation entails difficult, complex judgments to make sense of the information obtained.

This research effort seeks to develop analytic models of the intelligence analyst that will ultimately be used to develop computational models of tasks performed by intelligence analysts. The goal is to develop a prototype system to aid intelligence analysts (IAs) through the use of novel human-information interaction techniques and study the impact of these techniques on performance and learning in intelligence tasks. Information foraging theory (Pirolli and Card, 1998; Pirolli and Card, 1999) is being applied in this research on tasks that involve information-intensive work where the approach is to analyze the tasks as an attempt by the user to "maximize information gained per unit time." Models developed as a result of this research will be used to help intelligence analysts in locating and gathering information from large collections of information, synthesizing and developing an understanding of this information, and producing some product, such as a briefing or actionable decision.

Techniques to Enhance Processing of Intelligence Data

Recent world events have focused attention on some of the inherent challenges involved in performing intelligence analysis. As a result, increased research is being conducted to develop new training, tools, and techniques that will enhance the processing of intelligence data. For example, support and training in the organizing and piecing together aspects of intelligence analysis and decision making has been identified by the Assistant Secretary of Defense for Networks and Information Integration (OASD/NII) Research Program as an area that is greatly in need of more basic and applied research. One current research thread that seeks to address this need is the Novel Information from Massive Data (NIMD) program where the goal is to develop an "information manager" to assist analysts in dealing with the high volumes and disparate types of data that inundate intelligence analysts. The NIMD research program seeks to develop techniques that "structure data repositories to aid in revealing and interpreting novel contents" and techniques that can accurately model and draw inferences about (1) rare events and (2) sequences of events (widely and sparsely distributed over time).

Another related research thread involves constructing detailed models of users interacting with the World Wide Web (WWW), where the ultimate goal is to develop intelligent agents that can perform data mining in support of the intelligence mining process. A large source of information that is searched through by IAs for this task involves open-

source material (Connable, 2001). Pirolli, Fu, Reeder, and Card (2002) have developed a methodology for studying and analyzing ecologically valid WWW tasks. A user trace is created of all significant states and events in the user-WWW interaction based on analysis of eye tracking data, application-level logs, and think-aloud protocols. These researchers have applied this user-tracing architecture to develop simulation models of user-WWW interaction and to compare simulation models against user-trace data. When the same tasks as were presented to the observed users are presented to the simulation model, SNIF-ACT (Scent-based Navigation and Information Foraging in the ACT theory), the model simulates activity with the WWW to conduct the tasks.

Each action of the SNIF-ACT simulation is directly compared with observed user actions via the user-tracing architecture (Card, et al, 2001). This user-modeling research is being extended to develop computational models of intelligence analysts interacting with the WWW. Information foraging theory (Pirolli and Card, 1998; Pirolli and Card, 1999) is being applied in this research on tasks that involve information-intensive work where the approach is to analyze the tasks as an attempt by the user to maximize information gained per unit time.

The goal for the research described in this paper is to conduct a Cognitive Task Analysis (CTA) to collect the type of data that will support development of computational models of the intelligence analyst's processes, biases, and analytic strategies. The critical decision method (Klein Calderwood, & Macgregor, 1989) was modified to develop domain-specific cognitive probes that elicit information on how analysts obtain and use information, schemas employed to conceptualize the information, hypotheses developed to analyze this information, and products developed as a result of their analysis.

Cognitive Task Analysis

Our goal for conducting a CTA is to capture data that will provide input to support development of a computational model of the intelligence analyst's processes and analytic strategies. CTA is an extension of traditional task analysis techniques to produce information regarding the knowledge, cognitive strategies, and goal structures that provide the foundation for task performance (Chipman, Schraagen, and Shalin, 2000). The goal of CTA is to discover the cognitive activities that are required for performing a task in a particular domain to identify opportunities to improve performance by providing improved support of these activities (Potter, Roth, Woods, and Elm, 2000).

A detailed, accurate cognitive model that delineates the essential procedural and declarative knowledge is necessary to develop effective training procedures and systems (Annett, 2000). This entails building a model that captures the analysts' understanding of the demands of the domain, the knowledge and strategies of domain practitioners, and how existing artifacts influence performance. CTA can be viewed as a problem-solving process where the questions posed to the subject-matter experts, and the data collected, are tailored to produce answers to the research questions, such as training needs and how these training problems might be solved (DuBois & Shalin, 2000).

Use of multiple techniques

Analysis of a complex cognitive task, such the intelligence analyst's job, often requires the use of multiple techniques. When results from several techniques converge confidence is increased regarding the accuracy of the CTA model (Cooke, 1994; Hoffman, Shadbolt, Burton, & Klein, 1995; Potter, et al, 2000). During the initial bootstrapping phase of this research, several CTA approaches were examined with an eye toward determining which approach would be most productive for our domain of interest.

Applied Cognitive Task Analysis. The Applied Cognitive Task Analysis (ACTA) Method uses interview techniques to elicit information about the tasks performed and provides tools for representing knowledge (Militello and Hutton, 1998). Discovery of the difficult job elements, understanding expert strategies for effective performance, and identification of errors that a novice might make are objectives for using the ACTA method. The focus for researchers using the ACTA method is on interviews where domain practitioners describe critical incidents they have experienced while engaged in their tasks and aspects of the task that made the task difficult.

Many CTA techniques were developed and used for tasks that involve the practitioner making decisions and taking a course of action based on these decisions, e.g., firefighters, tank platoon leaders, structural engineers, paramedics, and computer programmers. One of the goals for many CTA techniques is to elicit information on actions taken and the decisions leading up to those actions is. However, the scenarios encountered during the IA's job do not fit this typical pattern because making a decision, and taking action/s based on these decisions, is not the immediate goal. One finding that emerged during the initial phase of this research was that making decisions is not a typical part of the IA's task. Instead, the major tasks consist of searching through vast amounts of data and information to filter, synthesize, and correlate the information to produce a report summarizing what is known about a particular situation or state of affairs. Then, the person for whom the report is produced takes actions based upon the information contained in the report.

Our use of the ACTA method produced valuable data for the initial bootstrapping phase of this research where the goal was to learn about the task, the cognitive challenges associated with task performance, and to determine what tasks to focus on during ensuing phases of the CTA research. A Knowledge Audit and a Cognitive Demands Table are typically produced when using the ACTA method. (Table 1, in the Results section, presents an example of one Cognitive Demands Table that was produced as a result of using the ACTA method.) During phase two we used a different method during our interviews to capture the essence of the IA's job. because the nature of the IAs task places greater emphasis on deductive reasoning, looking for patterns of activity, and making judgments about the level of risk present in a particular situation.

Critical Decision Method. The Critical Decision Method (CDM) is a semi-structured interview technique developed to obtain information about decisions made by practitioners when performing their tasks. Specific probe questions help experts describe what their task entails. CDM's emphasis on non-routine or difficult incidents produces a rich source of data about the performance of highly skilled personnel (Klein, Calderwood, & Macgregor, 1989). By focusing on critical incidents this method is also efficient as it aids in uncovering elements of expertise that might not be found in routine incidents (Klein & Hoffman, 1993). An emphasis on non-routine cases helps to ensure a

comprehensive coverage of the subject matter. In this paper we describe the development and use of a modified version of the CDM and preliminary results derived. The distinction is that we asked the study participants to describe an example of a strategic *analysis* problem in lieu of a critical decision problem. This method was modified to develop cognitive probes that elicit information on how analysts obtain and use information, schemas employed to conceptualize the information, hypotheses developed to analyze this information, and products developed as a result of their analysis.

METHOD

Procedures developed and used to conduct a modified version of the CDM are described in the following section. Interview probes were developed to ask participants to describe an example of a strategic analysis problem versus a critical decision problem.

Participants

Ten U.S. Navy officer-students, currently enrolled in a graduate school program at the Naval Postgraduate School (NPS), Monterey, CA, were interviewed. Participants were contacted via e-mail with the endorsement of their curriculum chair and were asked to volunteer for this study. These officers (O-3 - O-4) were students in either the Intelligence Information Management or the National Security Affairs curricula at NPS. Participants had an average of ten years experience working as intelligence analysts. Thus, these participants were considered experts as the literature generally defines an "expert" as an individual who has over ten years experience and "would be recognized as having achieved proficiency in their domain" (Klein, et al, 1989, p. 462).

Procedure

During phase one the objective was to begin studying the job to determine what tasks merit the detailed attention of a CTA and to identify a representative set of problems or cases. Information gathered during this phase served as an advance organizer by providing an overview of the task and helped to identify the cognitively complex elements of the task.

Phase One. Semi-structured interviews were conducted where intelligence analysts were asked to recall an incident from past experience. Analysts were asked to identify examples of the challenging aspects of their tasks and why these tasks are challenging, the cues and strategies that are used by practitioners, and to describe the context of the work. Interviews were scheduled for one and one-half hours at a time that was convenient for each participant. Three interviewers were present for each of the first six interviews. The interviews were tape-recorded and transcribed and the analysis was performed using the transcription and any other materials produced during the interview, e.g., task diagrams. The focus was on discovery of the difficult job elements, understanding expert strategies for effective performance, and identification of errors that a novice might make.

Domain experts were asked to describe critical incidents they had experienced on their job and aspects of the task that made the task difficult. The first group of intelligence analysts had a variety of assignments in their careers, however the majority of their experience was focused on performing analysis at the tactical level. (Tactical level

analysis refers to analysis of information that will impact mission performance within the local operating area, e.g., of the battle group, and generally within the next 24 hours.) During this bootstrapping phase of our CTA effort, we learned that there are several career paths for intelligence analysts. These career paths can be categorized as either having more of a technology emphasis where the focus is on systems, equipment, and managing the personnel who operate and maintain this equipment or an analytical emphasis where the focus and experience is on performing long-range analysis.

The ACTA method produced valuable data for the initial phase of this research where the goal was to learn about the task, the cognitive challenges associated, and determine what tasks to focus on during ensuing phases of the CTA research. After analyzing the data from the initial set of interviews, we determined that we needed to broaden the set of interview probes to uncover the bigger picture of how intelligence analysts approach performing their job. Descriptions of experiences at the tactical level did not provide examples of the types of problems or cases that could benefit from the training technology envisioned as the ultimate goal for this research. For the second group of interviews, interviewees were drawn from the National Security Affairs Department where there is stronger analytical emphasis in the curriculum and the analysts have had experience with analysis assignments at the strategic level. This second group of participants was very articulate in describing assignments where they performed analysis of critical topics at the strategic level.

Phase Two. During this second phase a structured set of domain-specific interview probes was developed specifically for use with this group of participants. One interviewer conducted the initial interviews; each interview lasted approximately one and one-half hours. Once the initial interview was analyzed, the participant was asked to return for a follow-up interview. All three interviewers were present for the follow-up interviews with this second group of intelligence analysts.

Since the major tasks for IA consist of searching through vast amounts of information to filter, synthesize, and summarize what is known about a particular situation or state of affairs interview probe questions provided in the literature were modified to capture information about their approach to gathering and analyzing information. Probes were developed to focus the discussion on a *critical analysis assignment* where the analyst had to produce a report on intelligence of a strategic nature. Interview probes were developed to capture information on the types of information used, how this information was obtained, and the strategies used to analyze this information.

Modified Critical Decision Method

A modified version of the critical decision method (CDM) was developed and used for this task domain. Interview probe questions provided in the literature (Hoffman, Coffey, and Ford, 2000) were modified to focus the discussion on a critical incident or assignment where the analyst had to collect, analyze, and produce a report on intelligence of a strategic nature. Examples of such strategic analysis problems might include assessments of the capabilities of nations or terrorist groups to obtain or produce weapons of mass destruction, terrorism, strategic surprise, political policy, or military policy. Participants were asked to describe what they did step-by-step and were asked to construct a timeline to illustrate the entire analysis process.

Deepening Probes. Domain-specific cognitive probes were developed to capture information on the types of information the IA was seeking, the types of questions the analyst was asking, and how this information was obtained. Additional information was collected on mental models used by analysts, hypotheses formulated and the types of products that are produced. Table 1 lists the questions posed to the participants during the initial interview. Topics for which participants conducted their analyses included modernization of a particular country's military, whether there would be a coup in the Philippines and the potential impact on the US if there was a coup, and the role for the newly created Department of Homeland Security.

Table 1. Modified Critical Decision Method: Deepening Probes

Probe Topic	Probe
Information	What information were you seeking, or what questions were you asking? Why did you need this information? How did you get that information? Were there any difficulties in getting the information you needed from that source? What was the volume of information that you had to deal with? What did you do with this information? Would some other information been helpful?
Mental Models/ Schemas	As you went through the process of analysis and understanding did you build a conceptual model? Did you try to imagine important events over time? Did you try to understand important actors and their relationships? Did you make a spatial picture in your head? Can you draw me an example of what it looks like?
Hypotheses	Did you formulate any hypotheses? Did you consider alternatives to those hypotheses? Did the hypotheses revise your plans for collecting and marshalling more information? If so, how?
Intermediate Products	Did you write any intermediate notes or sketches?

Follow-up Probes. Once the data from the initial interviews was transcribed and analyzed, participants were asked to return for a follow-up interview. The goal during this session was to refine our understanding of the IA's task. The analyst was asked to review the timeline produced during the first interview session and to elaborate on the procedures and cognitive strategies employed. Probes used during the follow-up interview are listed in Table 2.

Probes included questions about the participants' goals, whether this analysis was similar to other analysis assignments, use of analogues, and whether hypotheses were formed. Other probes asked about the types of questions raised during their analysis, methods used, information cues they used to seek and collate information, and the types of tools, e.g., computer software, they used to perform their analysis. During this second interview we went through the same intelligence analysis problem with the goal of obtaining additional details to refine our understanding of the entire analysis process. This included the types of information they used, and how they structured their analysis to answer the strategic question they had been assigned.

Table 2. Follow-up Probes Used for Modified Critical Decision Method

Probe Topic	Probes
Goals	What were your specific goals at the time?
Standard Scenarios	Does this case fit a standard or typical scenario? Does it fit a scenario you were trained to deal with?
Analogues	Did this case remind you of any previous case or experience?
Hypotheses and Questions	What hypotheses did you have? What questions were raised by that hypothesis? What alternative hypotheses did you consider? What questions were raised by that alternative hypothesis?
Information Cues for Hypotheses and Questions	As you collected and read information, what things triggered questions or hypotheses that you later followed up?
Information Tools	What sort of tools, such as computer applications, did you use? What information source did you use? What difficulties did you have?

RESULTS

A description of what has been learned during the first two phases of this CTA research with intelligence analysts is presented in this section. These results are based on analysis of data obtained during both phases of this research, i.e., using the ACTA method and the modified CDM method. During phase one, participants focused on providing descriptions of the cognitively challenging aspects of the task; often the discussion was focused on developing a product to support operations at the tactical level. (The tactical level generally refers to operations that will occur within hours or days.) During phase two, the emphasis was on describing tasks where the focus was on analysis of intelligence in order to produce a report to answer a question of interest at the strategic level. The length of time participants in phase two had devoted to the assignments that they described ranged from six weeks to three and one-half years.

Applied Cognitive Task Analysis

The initial set of knowledge representations for the IA's job (produced using the ACTA method) provided the basis for the more detailed CTA. Table 3 presents an example of the one of the tables that can be produced using the ACTA method. The Cognitive Demands Table was produced based on analysis of data captured during an interview with one participant during the first phase of this CTA research.

Table 3. Cognitive Demands Table: NPS#2

Cognitive Demand	Why Difficult	Cues	Strategies	Potential Errors
Synthesizing data	<ul style="list-style-type: none"> Lack of technical familiarity with different types of data Domain expertise is needed to analyze each class of data (HUMINT, SIGINT, ELINT, IMAGERY, etc.) 	Difficult to know how to weight different kinds of data	Emphasize type of data analyst has experience with, and disregard other data	<ul style="list-style-type: none"> Potential for biases Tendency to focus on type of data analyst has experience with and to ignore data you do not understand
Synthesizing data	<ul style="list-style-type: none"> No one database exists that can correlate across systems No one database can correlate all inputs from many different analysts to form one coherent picture 	Systems produce different "results," e.g., mensuration process produces different latitude/longitude coordinates from other systems	Different commands rely on different databases in which they have developed trust	<ul style="list-style-type: none"> Users develop comfort level with their system and its associated database; this can lead to wrong conclusion
Synthesizing Data	<ul style="list-style-type: none"> Databases are cumbersome to use: Poor correlation algorithms System presents results that users do not trust, tracks are "out of whack." 	Users don't always understand information system presents. Too many levels in system are not transparent	Use own experience	<ul style="list-style-type: none"> Rely on trend information
Noticing data	<ul style="list-style-type: none"> Time critical information is difficult to obtain Need to assimilate, verify and disseminate in a short time window 	Need to decide whether imagery is current enough to proceed with strike How long has it been there?	Need to rely on other sources to verify current	<ul style="list-style-type: none"> Refer to other sources to verify

Cognitive Challenges

The following paragraphs describe the cognitive challenges inherent in performing intelligence analysis.

Time Pressure

The IA task is made difficult by the confluence of several cognitive processing requirements. Time pressure to produce reports for decision-makers in shorter times is becoming an increasingly stressful requirement for analysts working at all levels, from tactical through strategic levels. As an example at the strategic level, one participant had six weeks to prepare a report on a matter of strategic importance; this included time to gather all the necessary information, analyze the information collected from diverse sources and produce the report. This analyst had no background knowledge of this area and had to begin by reading travel books and other general information. The assignment involved the question of whether President Estrada, of the Philippines, would be deposed as President, and if so, would there be a coup? This assignment was to include an analysis of what the impact would be on the U.S. As an example of time pressure at the tactical level, another participant described how the effect of timeline compression coupled with organizational constraints can sometimes "channel thinking" down a specific path.

Multiple Information Requirements and Complex Judgments

Multiple sources of disparate types of data (e.g., open source, classified, general reference materials, embassy cables, interviews with experts, military records, etc.) must be combined to predict complex, dynamic events. The cognitive challenges involved in merging information from these different sources can be especially difficult, e.g., how to filter and weight different kinds of data when the analyst lacks experience with all the different types of data. These different types of data have varying degrees of validity and reliability that must be considered. Moreover, domain expertise is often needed to analyze each type of data. For example, two analysts looking at the same image may see different things. Many factors need to be considered when interpreting imagery data, such as the time of day the image was taken, how probable it is to observe a certain thing, and trends within the particular country. A high level of cognitive workload is produced when a constant incoming stream of information must be continuously evaluated, updated and synthesized. An additional contributor to the high workload is the labor-intensive process employed when analysts process data manually because no one single database exists that can correlate across the various types of data that must be assimilated.

Difficult human judgments are involved in *(i)* considering the plausibility of information, *(ii)* deciding what information to trust, and *(iii)* determining how much weight to give specific pieces of data. One aspect of the IA task that is particularly challenging involves merging different types of information when the analyst does not have technical familiarity with all these types of information. Human intelligence, electronic intelligence, imagery, open source intelligence, measures and signals intelligence can all include spurious signals or inaccurate information due to the system used or to various factors associated with the different types of data. Analysts described situations where they gave greater weight to the types of information they understood and less weight to less understood information. Analysts must also resolve discrepancies across systems, databases, and services when correlation algorithms produce conflicting results or results that users do not trust.

High Cognitive Load. Intelligence analysts must perceive, filter, analyze, synthesize and determine the relevance of a continual stream of incoming information. This stream of information often pertains to several different situations. A critical part of the analyst's task involves projecting future anticipated events and making recommendations regard-

ing whether to task intelligence gathering sources to capture additional data. Analysts must assess, compare, and resolve conflicting information, while making difficult judgments and remembering the status of several evolving situations. These cognitive tasks are interleaved with other requisite tasks, such as producing various reports. For example, a request to gather additional information will often involve use of an asset that is in high demand. Re-tasking an asset can be costly, thus, tradeoffs must be made regarding the priority for use of an asset for one objective versus the potential gain in information when re-tasking the asset to satisfy a new objective.

The sheer volume of information makes it hard to process all the data, yet currently available technology is not always effective in helping the analyst assimilate the huge amount of information that needs to be synthesized. Databases exist but are cumbersome to use due to system design issues. Human judgment is entailed in deciding what information to trust and these judgments can be particularly difficult when they need to be made under time pressure. Each type of data has to be assessed to determine its validity, reliability, and relevance to the particular event undergoing analysis.

Potential for Cognitive Biases. The high mental workload imposed on IAs introduces a potential for cognitive biases to influence interpretation. The potential for “cognitive tunnel vision” to affect the analysis process is introduced by the high cognitive load that analysts often experience. For example, they may miss a key piece of information when they become overly focused on one particularly challenging aspect of the analysis. Bias may influence the analysis process when analysts attempt to reduce their cognitive load by analyzing data they understand and discounting data with which they have less experience. Additionally, discrepancies regarding interpretation may result when decision-makers at different locations (e.g., on different platforms, different services) rely on systems that produce different results. Moreover, the sheer volume of information makes it hard to process all the data, yet no technology is available that is effective in helping the analyst synthesize all the different types of information.

Schemas

In this example the person described his task of having to build a brief on a political question regarding whether President Estrada would be deposed from the Philippines, whether there would be a coup, and if there was a coup, what the implications would be for the U.S.? He was asked to complete this analysis task within a time span of six weeks. Figure 1 depicts a high-level representation of this task. From the initial search of raw reports he produced an initial profile. Many follow-up phone calls and additional searches were conducted to fill the gaps and elaborate on what was learned during the initial set of queries. This step resulted in producing a large number of individual word files on each political person or key player. These included biographies on approximately 125 people, including insurgency leaders, people in various political groups, people with ties to crime, etc. The information in these files was then grouped in various ways. He developed a set of questions to use to work backwards to review all the material from several different vantage points to answer questions, such as: Will there be a coup? Will it be peaceful or not? Will it be backed by the military? Will the vote proceed, or will the military step in, prior to the vote? What is the most likely scenario to pan out?

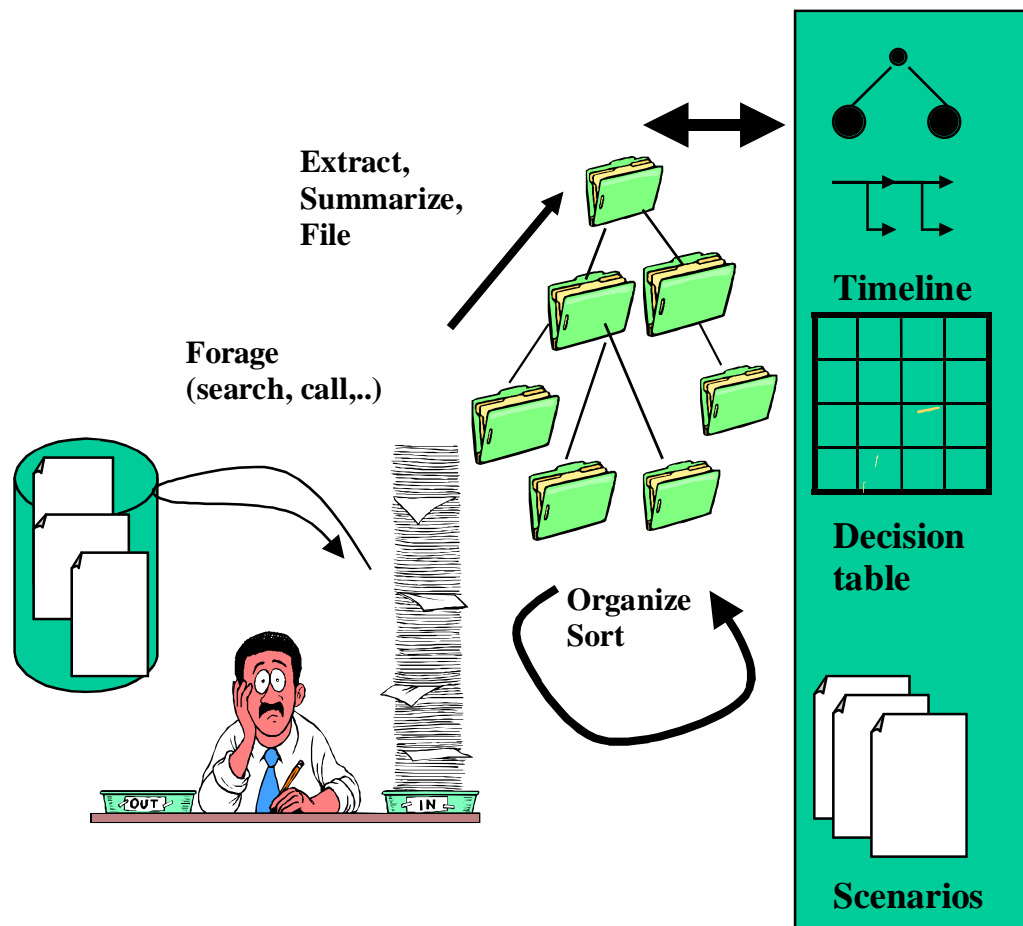

Figure 1. NSA Expert on "Will Estrada Be Overthrown in a Military Coup?"

Figure 2 depicts the various information sources that the analyst researched to develop a comprehensive understanding of the issue. The analyst began, in week one, by reading general background information to develop knowledge on the history and cultural ethnography of the country and also by examining prior Naval Intelligence on the previous history for political turnover in the Philippines. During week two he began contacting Intelligence Centers and reading U.S. Embassy cables, an important source for this particular topic. While this step provided valuable information this material was from a secondary source, that is, it represented someone else's analysis of the situation. This necessitated the analyst having to decide which of these reports were to be given more emphasis and in which ones he could not place as much confidence.

One way the analyst structured his analysis was by sorting people according to whether they were pro-Estrada or anti-Estrada, which figures would be likely to drop allegiance to the constitution? and so on. Several people involved in coup attempts around the time of President Aquino were now senators. Voting records provided another way to sort people. Political figures' ties to certain newspapers were examined to determine which camps they would fall into. He attempted to determine what biases key figures might have. There were many branches and sequels, thus many ways to sort the information.

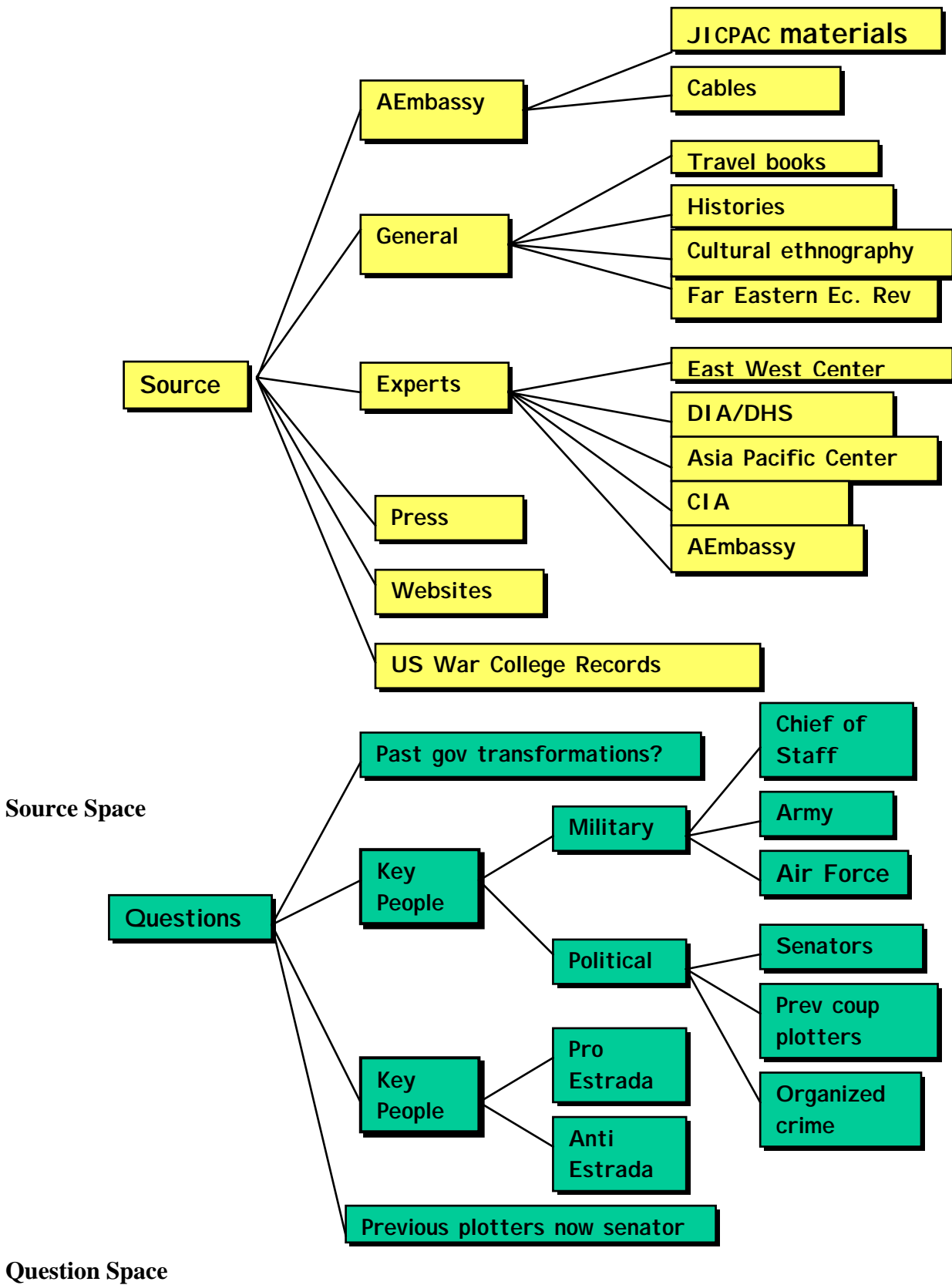

Figure 2. Information Foraging: Dual Problem Space

Figure 3 depicts the information schema used by for this analyst. Multiple ways of grouping people were used to consider how their allegiance would "fall out" based on their various associations. For example, he grouped key people in both the military and civilian sectors according to their military associations, political, family, geographic region, and various other associations to determine whether they were pro-Aquino or anti-Aquino. Other ways of trying to ascertain their loyalty involved examination of other types of affiliations, for example, boards they belong to. The analyst developed many branches and sequels between people and events in his attempt to examine their affiliations from many different vantage points. He also reviewed past coup attempts that occurred around the time of past-President Aquino to examine how these people's allegiances might develop. Another approach employed was to try to ascertain which camp certain political players would fall into by various groups and activities they were associated with, e.g., certain newspapers.

SCHEMAS

•KEY PLAYERS

MILITARY

ARMY

REGION 1

<Commander>

•FAMILIES

<Assistants>

REGION 2

<Commander>

<Assistants>

...

LOGISTICS

INTEL

PERSONNEL

AIR FORCE

...

•CLIQUE ASSOCIATIONS

SAME UNIT

SAME REGION OF ORIGIN

CLASSMATES

FAMILY RELATIONSHIP

PAST CO-PLOTTER

BOARD CO-MEMBERSHIP

BUSINESS TIES

POLITICAL

SENATORS

CLERGY

PREV COUP PLOTTERS

POLITICAL PARTIES

POLITICAL ACTION GRPS

POLITICAL FRONT ORGS

OTHERS

ORGANIZED CRIME

PRESS

PROMINENT

INVOLVED SOME WAY

■ SOURCES

GENERAL LIT

JICPAC

CABLES

WEBSITES

EXPERTS

■ ATTITUDES

PRO-AQUINO

ANTI-AQUINO

Figure 3. Schemas Used to Analyze the Intelligence Problem

Summary

Identification of an appropriate sample of problems or tasks is essential, particularly in developing training techniques, to ensure sufficient coverage of critical skills and

knowledge. The initial set of interviews was conducted to develop a foundation of knowledge regarding the Intelligence Analysts' task domain. This first phase of the research served to identify parts of the job that require skilled judgment and evaluation. During the next phase of this research, additional analytical evidence and empirical data will be gathered to further refine and verify the CTA model of the intelligence information analyst's job. One goal for this phase will be to predict or envision the impact the technology will have on cognition for the intelligence analyst. A second goal is to influence the development process so the new training is useful.

DISCUSSION

One goal for this effort is to capture data that will provide input to building models of the IA and analytic processes used to perform intelligence analysis. The goal of CTA is to discover the cognitive activities that are required for performing a task to identify opportunities to improve performance by providing improved support of these activities. A detailed, accurate cognitive model that delineates the essential procedural and declarative knowledge is necessary to develop effective training procedures and systems. This entails building a model that captures the analysts' understanding of the demands of the domain, the knowledge and strategies of domain practitioners, and how existing artifacts influence performance. The major impact of the work described above will be to provide data that will be used to develop computational models of the IA process. Models developed as a result of this research will be used to help analysts in locating and gathering information from large collections of information, synthesizing and developing an understanding of this information.

FUTURE RESEARCH

The next phase of this research will involve presenting an analysis task and observing the IA while performing the task in a controlled laboratory environment. Data will be collected using an eye tracker, logging software that collects all user actions with a WWW browser, and video recordings of think-aloud verbal protocols (Card, et al., 2001; Pirolli, Fu, Reeder, and Card, 2002). Working within a system development process, to support critical system design issues, additional data and empirical evidence will be collected. The CTA process is an iterative process that builds on subsequent design activities. Phase three will continue to refine the model by continued exploration of the domain and the way practitioners operate in the domain. Introducing new technology will impact task performance. New tools and training will impact the cognitive activities to be performed and enable development of new strategies. CTA techniques that might be useful during this phase include storyboarding, participatory design, rapid prototype evaluations, and observations of performance using various degrees of fidelity.

ACKNOWLEDGEMENTS

This research was supported by the Office of Naval Research, Dr. Susan Chipman.

REFERENCES

- Annett, J. (2000). Theoretical and Pragmatic Influences on Task Analysis Methods. In J. M. Schraagen, S. F. Chipman, & V. L. Shalin (Eds.), *Cognitive Task Analysis*, (pp. 25-37). Mahwah, NJ: Erlbaum.
- Card, S., et al. (2001). Using Information Scent as a Driver of Web Behavior Graphs: Results of a Protocol Analysis Method for Web Usability. In *Human Factors in Computing Systems*. Seattle, WA.
- Chipman, S. F., Schraagen, J. M., and Shalin, V. L. (2000). Introduction to Cognitive Task Analysis. In J. M. Schraagen, S. F. Chipman, & V. L. Shalin (Eds.), *Cognitive Task Analysis*, (pp. 3-23). Lawrence Erlbaum Associates, Mahwah, NJ: Erlbaum.
- Connable, A. B. (2001). Open Source Acquisition and Analysis: Leveraging the Future of Intelligence at the United States Central Command. Masters Thesis, Naval Postgraduate School, Monterey, CA. June 2001.
- Cooke, N. J. (1994). Varieties of Knowledge Elicitation Techniques. *International Journal of Human-Computer Studies*. 41, 801-849.
- DuBois, D. & Shalin, V. L. (2000). Describing Job Expertise Using Cognitively Oriented Task Analyses (COTA) In J. M. Schraagen, S. F. Chipman, & V. L. Shalin (Eds.), *Cognitive Task Analysis*, (pp. 317-340). Lawrence Erlbaum Associates, Mahwah, NJ: Erlbaum.
- Hoffman, R. R., Shadbolt, N. R., Burton, A. M., & Klein, G. (1995) Eliciting Knowledge from Experts: A Methodological Analysis. *Organizational Behavior and Human Decision Processes*. Vol. 62, No. 2, May, pp. 129-158.
- Hoffman, R. R., Coffey, J. W., and Ford, K. M. (2000). *The Handbook of Human-Centered Computing*. Pensacola, FL: Institute for Human and Machine Cognition.
- Klein, G. A., Calderwood, R., and Macgregor, D. (1989, May/June). Critical Decision Method for Eliciting Knowledge. *IEEE Transactions on Systems, Man, and Cybernetics*, Vol. 19, No. 3.
- Krizen, L. (1999). *Intelligence Essentials for Everyone*. Joint Military Intelligence College: Washington, DC.
- NIMD, 2002. Novel Information from Massive Data, Advanced Research and Development Agency, http://www.ic-arda.org/Novel_Intelligence/mass_data_struct_org_norm.htm.
- Militello, L. G., and Hutton, R. J. B. (1998). Applied Cognitive Task Analysis (ACTA): A Practitioners Toolkit for Understanding Task Demands. *Ergonomics*, 41, 164-168.
- Pirolli, P. and Card, S. K. (1998). Information foraging models of browsers for very large document spaces. In *Advanced Visual Interfaces Workshop, AVI '98*. Aquila, Italy, ACM.
- Pirolli, P., and Card, S. K. (1999). Information foraging. *Psychological Review*, 106, p. 643-675.
- Pirolli, P., Fu, W-T., Reeder, R., and Card, S. K. (2002). A User-Tracing Architecture for Modeling Interaction with the World Wide Web. In *Advanced Visual Interfaces. AVI 2002*. 2002. Trento, Italy: ACM Press.
- Potter, S. S., Roth, E. M., Woods, D. D., and Elm, W. C. (2000). Bootstrapping Multiple Converging Cognitive Task Analysis Techniques for System Design.



A New Perspective on Use of the Critical Decision Method with Intelligence Analysts

Susan G. Hutchins, Naval Postgraduate School

Peter Pirolli, Xerox PARC

Stuart Card, Xerox PARC



Background: Intelligence Analysis

- **Sort through vast amounts of information to construct an accurate depiction of a situation**
 - Products of information foraging and analysis are used by senior decisionmakers to make high-stakes decisions
- **Complex process of assessing reliability of information from wide variety of sources and combining seemingly unrelated events**
 - Involves data mining, data correlation, human judgment
- **CTA – capture data to provide input to support development of a computational model of the IA's processes, biases, analytic strategies**
 - New method needed: scenarios do not fit typical pattern of making decisions and taking actions
 - Many CTA techniques have goal: elicit information on actions taken and decisions leading up to those actions
 - Greater emphasis on deductive reasoning, looking for patterns of activity, and making judgment about the level of risk present
- **Needed to take different tack during interviews to capture essence IA's job**
 - Participants were asked to describe an example of a strategic *analysis* problem



Cognitive Task Analysis Methodology

- **Participants: 10 military officer-students enrolled in NPS graduate school program**
 - 6 Intelligence Information Management; 4 National Security Affairs
 - Average 10 years experience as intelligence analysts
- **Phase One: Semi-structured interviews - Knowledge Audit (ACTA)**
 - Identify challenging aspects of their jobs, cues and strategies
 - Needed broader set of probes to uncover bigger picture
- **Phase Two: Draws from a variety of CTA methods**
 - Critical Decision Method (Klein, et al.; Hoffman, et al.)
 - Tailored to Intelligence Analysts
 - Interview probes developed to focus on a critical assignment where analyst had to collect, analyze and produce report of strategic nature
 - Types of information used, how information was obtained



Critical Decision Method



We are interested in the collection, analysis, and reporting of intelligence of strategic importance (as opposed to tactical or operational intelligence). Examples of such strategic analysis problems might include assessments of the capabilities of nations or terrorist groups to obtain or produce weapons of mass destruction, terrorism, strategic surprise, political policy, military policy etc.

Please try to recall a recent significant assignment in which you had to collect, analyze, and report on an intelligence problem of a strategic nature (for example, a class assignment that resulted in a paper, talk, briefing, etc.).

When was it?

Where (in what course) was it?

What was the specific assignment?

What was the final product, product length, and product audience?

How much time was devoted to this task?

Over what period of time?

What specific training or experience did you have that was particularly relevant to accomplishing this assignment?

What did you do step by step? (use as much space as needed to construct timeline)



CDM - Deepening



Information	<p>What information were you seeking, or what questions were you asking?</p> <p>Why did you need this information?</p> <p>How did you get that information? What was the information source?</p> <p>Are there any difficulties in getting the information you needed from that source?</p> <p>What was the volume of information that you had to deal with?</p> <p>What did you do with this information?</p> <p>Would some other information been helpful?</p>
Mental models/Schemas	<p>As you went through the process of analysis and understanding did you build a conceptual model?</p> <p>Did you try to imagine important events over time?</p> <p>Did you try to understand important actors and their relationships?</p> <p>Did you make a spatial picture in your head?</p> <p>Can you draw me an example of what it looks like?</p>
Hypotheses	<p>Did you formulate any hypotheses?</p> <p>Did you consider alternatives to those hypotheses?</p> <p>Did the hypotheses revise your plans for collecting and marshalling more information? If so, how?</p>
Intermediate products	<p>Did you write any intermediate notes or sketches?</p>



CDM - Follow-up

In the last interview, you provided us with an interesting example of an analysis that you had performed. In today's interview we would like to go through that analysis again to verify and elaborate our understanding of that example analysis.

Probe Topic	Probes
Goals	What were your specific goals at the time?
Standard Scenarios	Does this case fit a standard or typical scenario? Does it fit a scenario you were trained to deal with?
Analogues	Did this case remind you of any previous case or experience?
Hypotheses & questions	What hypotheses did you have? What questions were raised by that hypothesis? What alternative hypotheses did you consider? What questions were raised by that alternative hypothesis?
Methods	Were you following a method you had learned or developed in the past and, if so, can you describe it?
Information cues for hypotheses and questions	As you collected and read information, what things triggered questions or hypotheses that you later followed up?
Information tools	What sort of tools, such as computer applications, did you use? What information source did you use? What difficulties did you have?

We are interested in performing more detailed observations of analysts as they solve some tasks. Our general idea is to develop a set of tasks and related materials that we could present to analysts to solve. We would then record how they solved the task. We would like the task to involve the collection of open source information, some analysis, and some product such as a briefing or paper. We would like to see if there is some version of the case you just recalled that could be used in our studies.

Is there some version of your case that could be done by an analyst in one day to a week?

What materials would be needed?

Cognitive Demands for Intelligence Analysts

- **Noticing Data**
 - Time critical data difficult to obtain
 - Two analysts looking at same picture/ image can see different things
 - Need background knowledge, expertise working with each type of data e.g., trends of country, etc. influence interpretation
 - Classify data: Relevant/ irrelevant
 - Distilling the relevance: “5 gems” from 100 reports
- **Synthesizing Data**
 - Need to assimilate, verify, and disseminate in short time window
 - Combine seemingly unrelated events and see the relevance
 - Avoid cognitive biases
 - Tunnel vision: So focused on one thing, miss key piece of puzzle
 - Confirmation bias: Discount/ ignore data don't understand, emphasize type of data most experienced with
 - Prior knowledge used to assess validity, reliability
 - Domain expertise needed to analyze each class of data

Cognitive Demands for Intelligence Analysts

- **High Cognitive Workload:** GOAL: Predict complex, dynamic events
 - Timeline compression coupled with organizational constraints → “channels thinking down a specific path”
 - High cognitive complexity entailed to assess reliability and synthesize info from wide variety of sources: Is it possible? Plausible? Other sources corroborate?
 - Difficult judgments dealing with ambiguous data
 - All types of data can include spurious signals, inaccurate information
 - How to filter and how much weight to give to each specific piece?
 - Domain expertise needed to analyze each type (SIGINT, HUMINT, ELINT, IMAGERY, MASINT, Open Source)
 - Which pieces tie together? Can I trust this info?
 - Overwhelmed with massive amounts of data
 - Need to resolve discrepancies across systems, databases, etc.
 - Need to interpret data in context
 - Time pressure becoming increasingly stressful requirement
 - “Incredible time crunch:” Pressure to give more info, and faster, to the customer
 - Sheer volume makes it difficult to process; yet no technology available to effectively help synthesize different types of info
- **Cumbersome Databases**
 - Poor correlation algorithms
 - System presents results users do not trust: “tracks out of whack”
 - Analysts processes data manually → Adds to cognitive load

Cognitive Demands for Intelligence Analysts

- **Decisions regarding Information Requirements**
 - Decide whether additional data is required
 - Who to go to for specific information?
 - What system is best to get particular types of information?
 - Re-task an asset? (expensive, involves trade-offs)
 - How to be efficient with limited assets, yet many requirements?
- **Disseminate**
 - Need to understand customer, context, big picture
 - Don't overload "customer"/ but don't starve, i.e., don't decide for them when they need to know something
 - Customer doesn't articulate need/ provide reasons for needing info
 - Avoid Groupthink, "Boy who Cried Wolf"
- **Cultural Issues**
 - Credibility: Operational guys "rarely understand analysis"
 - Attitude: "Why do I need you?"

C O G N I T I V E D E M A N D S T A B L E : S#2

C O G N I T I V E D E M A N D	W H Y D I F F I C U L T	C U E S	S T R A T E G I E S	P O T E N T I A L E R R O R S
Synthesizing data	Lack of technical familiarity with different types of data. Domain expertise is needed to analyze each class of data (HUMANITY, SIGNATURE, IMAGE, etc.)	Difficult to know how to weight different kinds of data	Emphasize type of data analyst has experience with, and disregard	Potential for bias. Tendency to disregard what you understand. Tend to emphasize type of experience with disregard other
Synthesizing data	No one database exists that can correlate across systems. No database can synthesize all various inputs (from any different analysts) to form one coherent picture	Systems produce different "results," e.g., mensuration process produce different latitude / longitude coordinates they have	Users develop preferences for system they are familiar with. Different commands rely on different data bases in which they have developed trust	Users develop confidence with their and its associated database can lead to bias or wrong conclusion
Synthesizing data	Different platforms rely on different systems	Users don't always understand information the system presents	Users develop comfort level with their system	Tendency to emphasize size type of data analyst has experience with to disregard other information.
Synthesizing Data	Databases are cumbersome to use	Users don't always understand information the system presents. System presents that users don't trust, e.g., tracks are "out of wack."	Too many levels within system not transparent to results	Rely on trend information. Use own experience algorithms user
Noticing data	Time critical information is difficult to obtain	Need to decide whether the information is current enough to proceed with strike.	Need to rely on other sources to verify current location (e.g.,	Refer to other sources to verify. Need to assume SIGNATURE, or H
verify		in short time	and disseminate. How long has it been	Window
Noticing data	Two analysts looking different things	Need to consider time of day image was taken, how realistic/probable it is to see a certain	Need to have knowledge. Be aware of trends of the country, and	ZZZ Tendency to underestimate possibility for error



Naval Intelligence Analyst NPS2-2

- **Task:**
 - Will Estrada be deposed from presidency of Philippine Islands? Will there be a coup?
- **Deadline:**
 - 6 weeks
- **Time worked on task:**
 - Student estimate 72 h/week x 6 weeks
 - Our estimate 300~400 h.

NPS2-2: Will Estrada be Overthrown in a Military Coup?

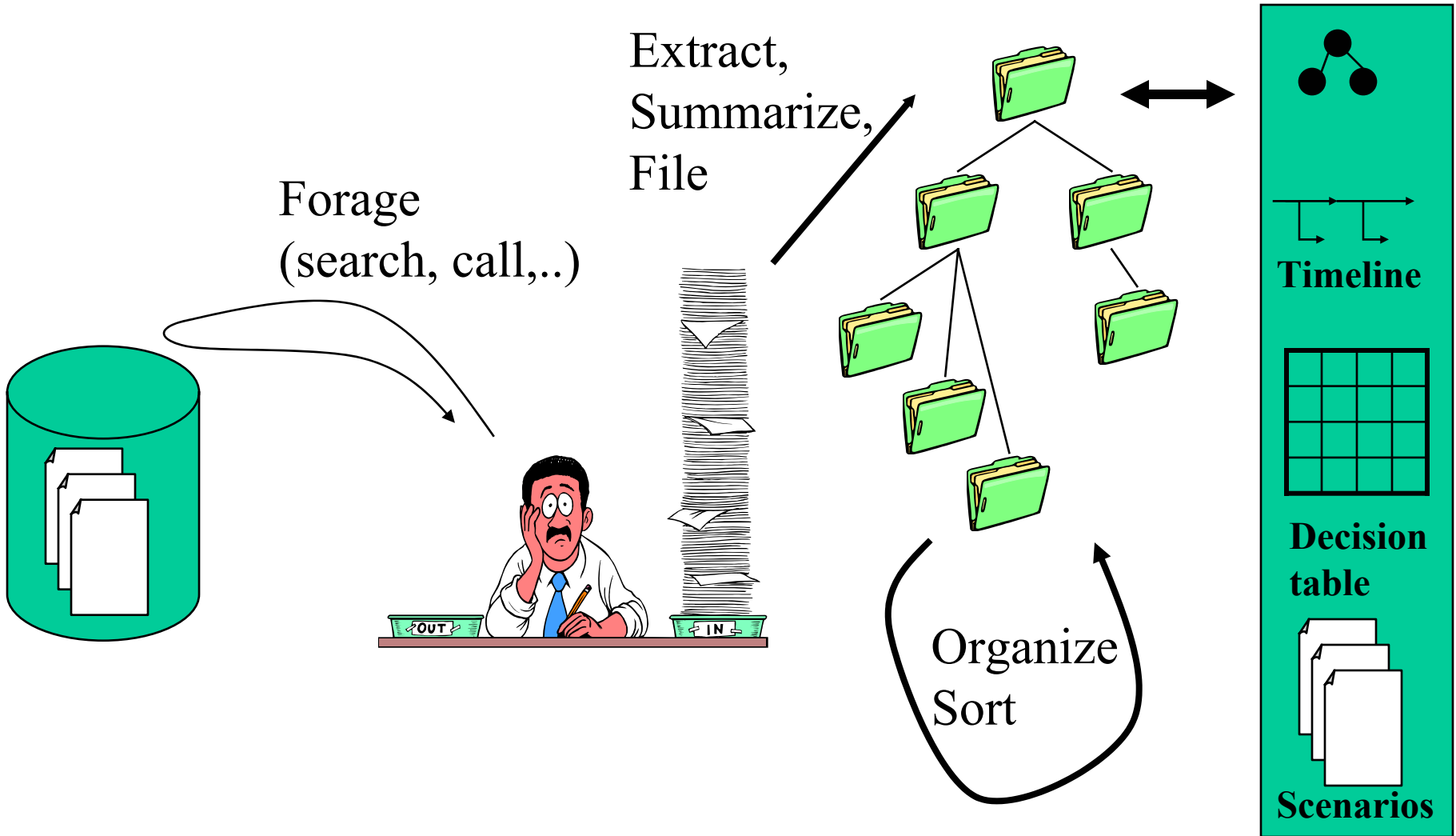



INFORMATION FORAGING: Dual Problem Space Space



(1) Source space

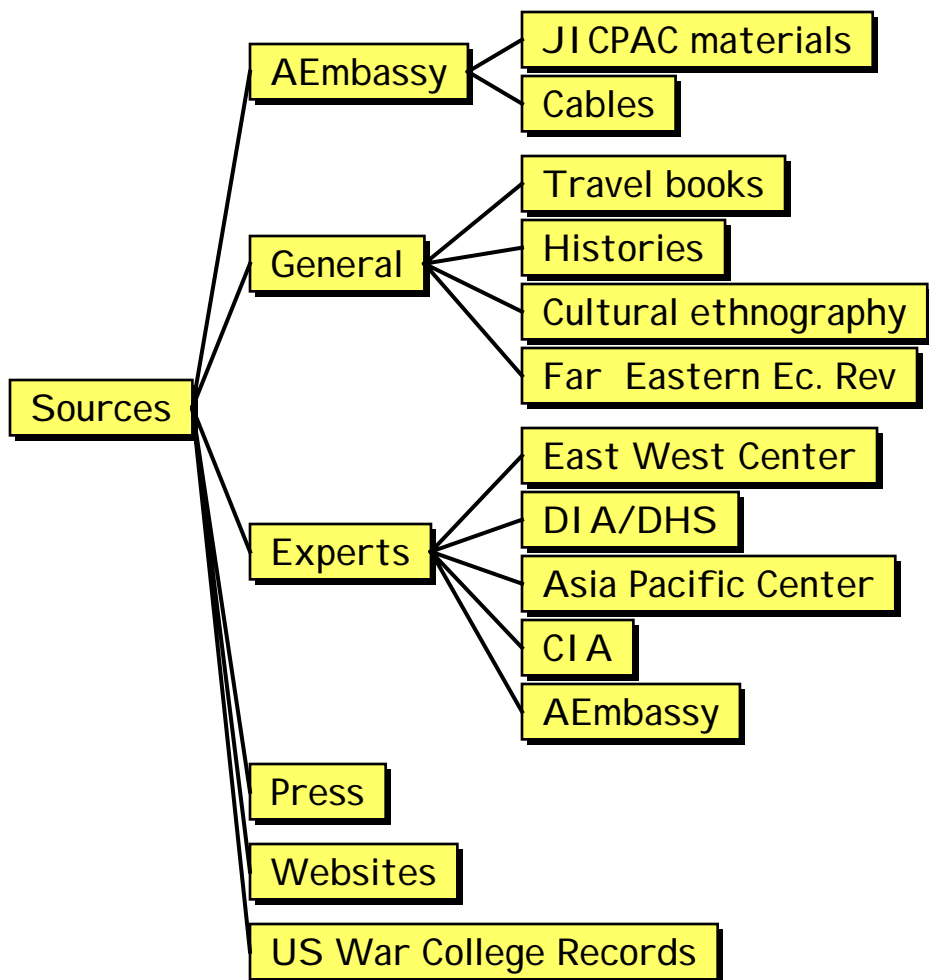

(2) Question space

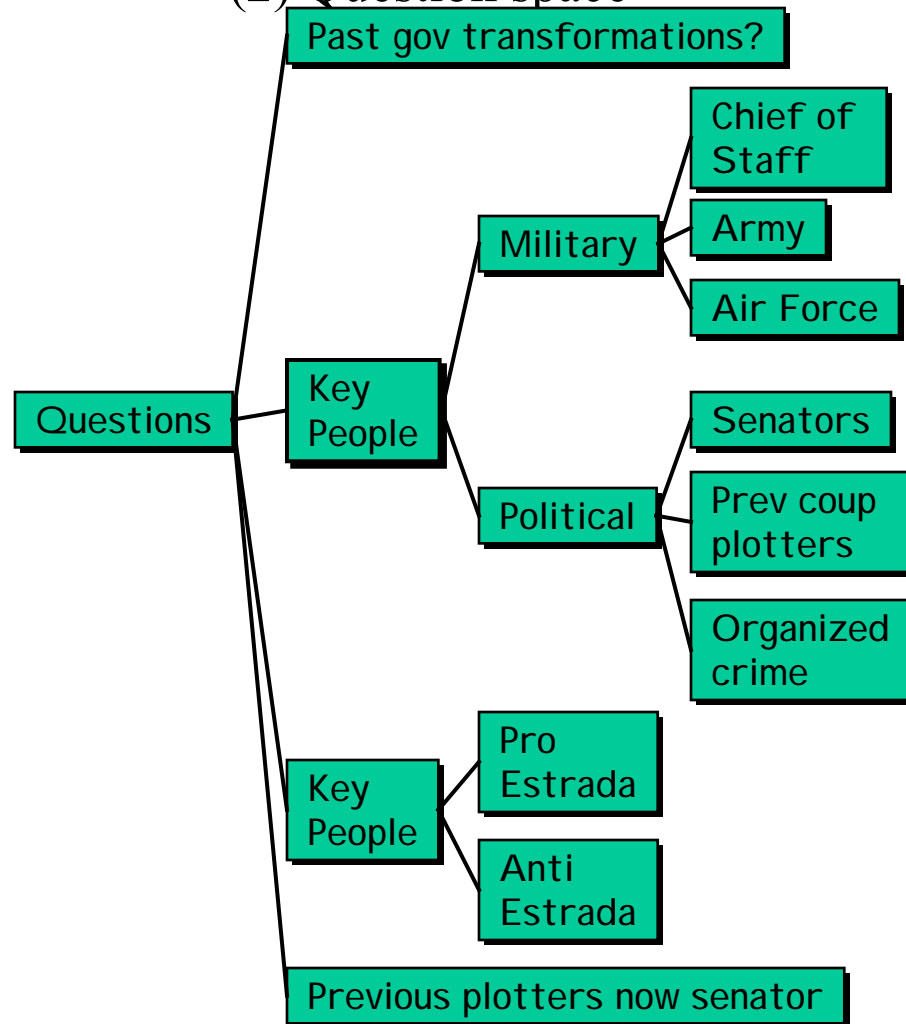

Schemas

- **KEY PLAYERS**

MILITARY

ARMY

REGION 1

<Commander>

FAMILIES

<Assistants>

REGION 2

<Commander>

<Assistants>

...

LOGISTICS

INTEL

PERSONNEL

AIR FORCE

...

POLITICAL

SENATORS

CLERGY

PREV COUP PLOTTERS

POLITICAL PARTIES

POLITICAL ACTION GRPS

POLITICAL FRONT ORGS

OTHERS

ORGANIZED CRIME

PRESS

PROMINENT

INVOLVED SOME WAY

- **CLIQUE ASSOCIATIONS**

SAME UNIT

SAME REGION OF ORIGIN

CLASSMATES

FAMILY RELATIONSHIP

PAST CO-PLOTTER

BOARD CO-MEMBERSHIP

BUSINESS TIES

- **SOURCES**

GENERAL LIT

JICPAC

CABLES

WEBSITES

EXPERTS

- **ATTITUDES**

PRO-AQUINO

ANTI-AQUINO

Example

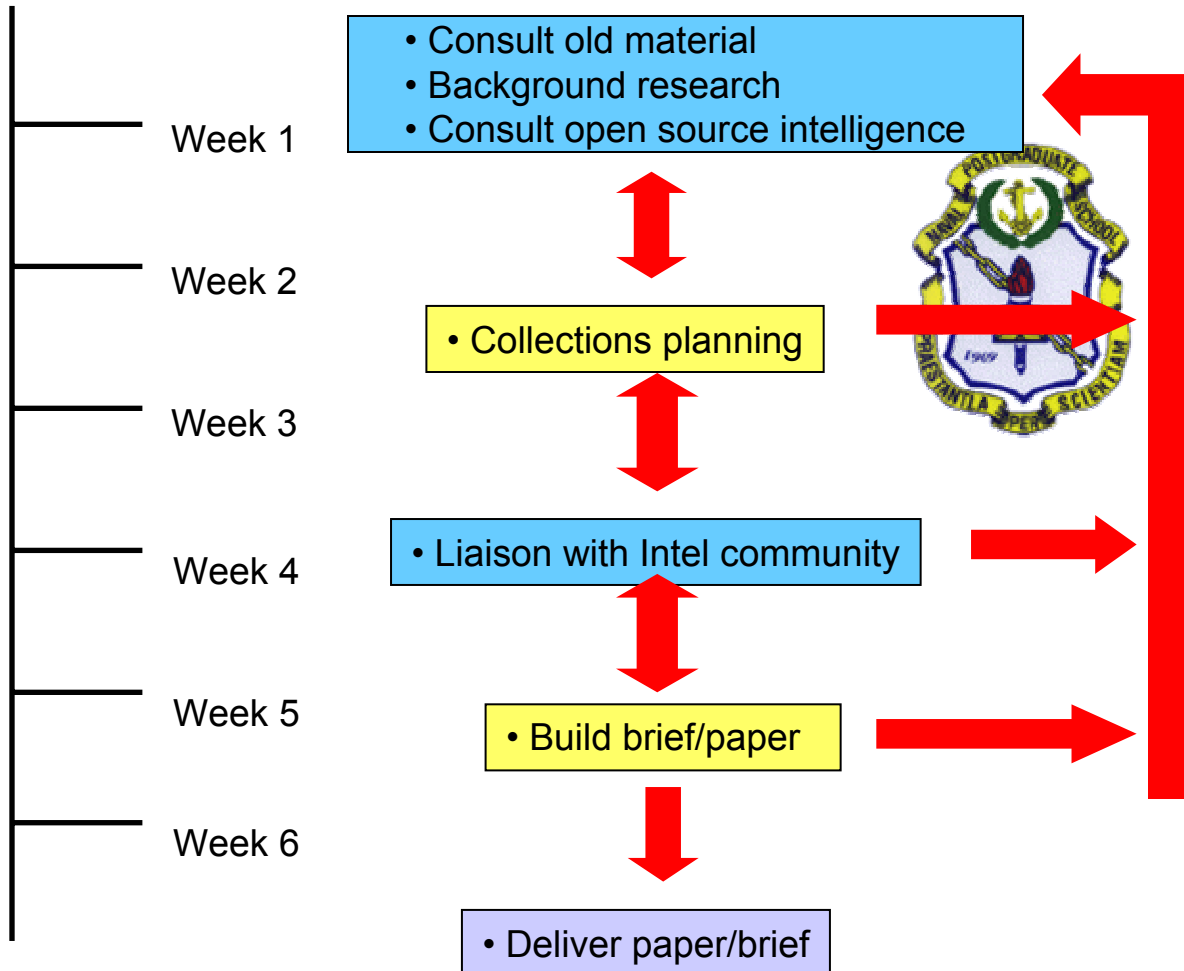



Just-in-Time Capsule Briefings

Support post-graduate education in intelligence analysis

JITC Briefing toolkit

Quickly gather info, organize, analyze, and communicate an intel briefing

E.g., Observed Chinese naval maneuvers vs stated doctrine

E.g., Immediate likelihood of unfriendly military coup in the Philippines

Build on

Psychological studies of intelligence process

Exemplary human-information interaction technology

Web Behavior Graphs (WBGs)

S1

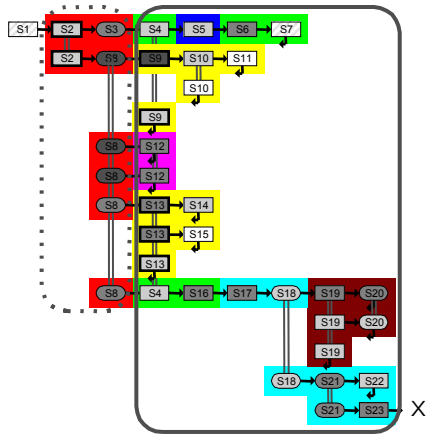

S6

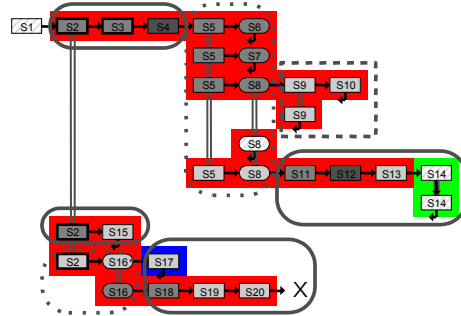

S7

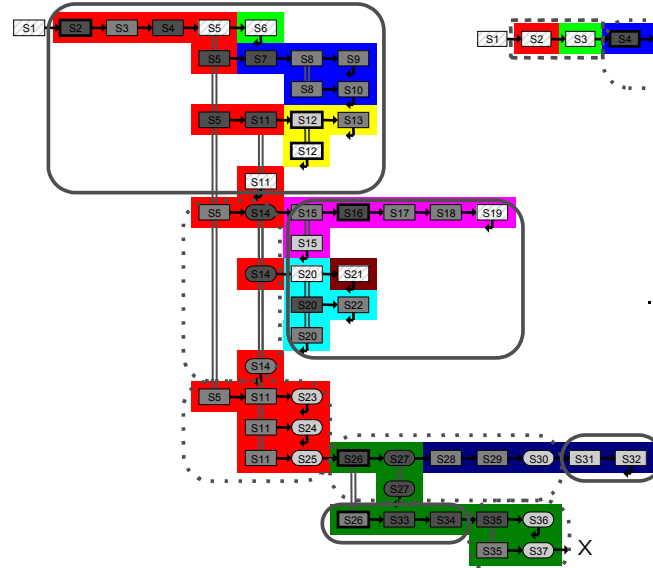

ANTZ
S10

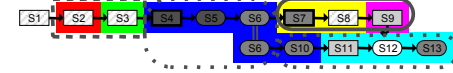

CITY

S1

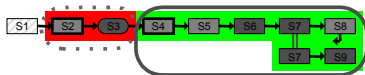

S6

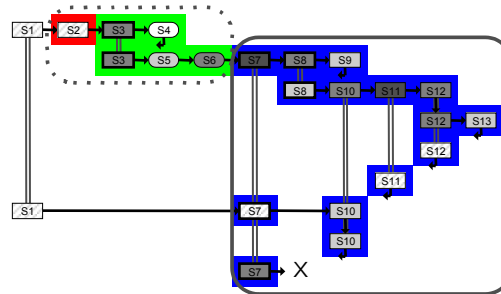

S7

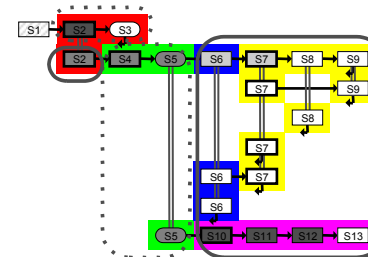

S10

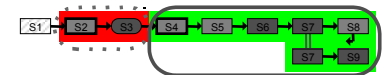

Summary: Critical Decision Method

- **CTA was conducted to support development of a model of the intelligence analyst's processes, biases, and analytic strategies**
 - **Goal: Provide input to build a computational model of analysis process**
- **Needed to uncover a different kind of domain knowledge**
 - **Critical Decision Method was tailored to focus on analysis**
 - **How an Intelligence Analyst goes about the task of analyzing a complex issue of strategic concern**
- **Analysis of a complex cognitive task, such the intelligence analyst's job, often requires the use of multiple techniques.**
 - **When results from several techniques converge, confidence is increased regarding the accuracy of the CTA model.**
 - **Method is still evolving**
 - **Next steps: Additional interviews and observe analysts perform task using open-source information on www**