

Configuration Management Support for Long Haul C2 Circuit Switched Services

Robert Sligh

The MITRE Corporation
M/S W655
7515 Colshire Drive
McLean, VA 22101-7508

George Wong

The MITRE Corporation
M/S W655
7515 Colshire Drive
McLean, VA 22101-7508

Sandi Vest

Center for DISN Services
Defense Information System Agency
5275 Leesburg Pike
Falls Church, VA 22041

Report Documentation Page

Form Approved
OMB No. 0704-0188

Public reporting burden for the collection of information is estimated to average 1 hour per response, including the time for reviewing instructions, searching existing data sources, gathering and maintaining the data needed, and completing and reviewing the collection of information. Send comments regarding this burden estimate or any other aspect of this collection of information, including suggestions for reducing this burden, to Washington Headquarters Services, Directorate for Information Operations and Reports, 1215 Jefferson Davis Highway, Suite 1204, Arlington VA 22202-4302. Respondents should be aware that notwithstanding any other provision of law, no person shall be subject to a penalty for failing to comply with a collection of information if it does not display a currently valid OMB control number.

1. REPORT DATE SEP 2002		2. REPORT TYPE		3. DATES COVERED 00-00-2002 to 00-00-2002	
4. TITLE AND SUBTITLE Configuration Management Support for Long Haul C2 Circuit Switched Services				5a. CONTRACT NUMBER	
				5b. GRANT NUMBER	
				5c. PROGRAM ELEMENT NUMBER	
6. AUTHOR(S)				5d. PROJECT NUMBER	
				5e. TASK NUMBER	
				5f. WORK UNIT NUMBER	
7. PERFORMING ORGANIZATION NAME(S) AND ADDRESS(ES) The MITRE Corporation,7515 Colshire Drive M/S W655,McLean,VA,22101-7508				8. PERFORMING ORGANIZATION REPORT NUMBER	
9. SPONSORING/MONITORING AGENCY NAME(S) AND ADDRESS(ES)				10. SPONSOR/MONITOR'S ACRONYM(S)	
				11. SPONSOR/MONITOR'S REPORT NUMBER(S)	
12. DISTRIBUTION/AVAILABILITY STATEMENT Approved for public release; distribution unlimited					
13. SUPPLEMENTARY NOTES The original document contains color images.					
14. ABSTRACT					
15. SUBJECT TERMS					
16. SECURITY CLASSIFICATION OF:			17. LIMITATION OF ABSTRACT	18. NUMBER OF PAGES 14	19a. NAME OF RESPONSIBLE PERSON
a. REPORT unclassified	b. ABSTRACT unclassified	c. THIS PAGE unclassified			

Abstract

To ensure our warfighting edge in information superiority across all joined forces, we must keep pace with technology advancement and build a state of the art network infrastructure that can adapt to changing needs and provide fast and reliable service delivery anytime, and anywhere in the world. This paper addresses the challenges that the Defense Switched Network (DSN) faces, and offers a Configuration Management (CM) solution that is built upon a common DSN Core CM database with automated support systems to support integration of various Network Management functions.

1.0 Introduction

The primary function of the Defense Switched Network (DSN) is to provide non-secure dial-up voice service. It also supports Switched Data and dial-up Video Teleconferencing (VTC) for the Department of Defense (DOD) common-user video teleconferencing system. The DSN supports three types of users: Special C2 Users, C2 Users, and Other Users.

Within DSN, there are multiple organizations that take part in the overall DSN Program. Each organization is responsible for a certain operational functions and performs a sub-section of the Configuration Management process (identification, audits, control, and status accounting). Most CM functions are performed manually and have received minimal automated support. This was due to Operations and Maintenance needs, which dictated that automation efforts focus on Fault and Performance management.

1.1 Purpose

This paper addresses how Configuration Management (CM) will be enhanced, automated, and applied in support of the Defense Switched Network (DSN). It includes the approach in developing requirements, a summary description of the functional model used in analyzing existing processes and modifying and/developing additional processes, the operational concept, the development and implementation approach and current status.

1.2 Limitation

This paper focus on the DSN and its long-haul circuit switched services. Other networks and services within the Defense Information System Network (DISN) are not being addressed herein but will be incorporated after the DSN CM is operational.

1.3 Background

To ensure our warfighting edge and information superiority across all joined forces, we must keep pace with technology advancement and build a state of the art network infrastructure that can adapt to changing needs and provide fast and reliable service delivery anytime, anywhere in the world. To achieve this objective, DISA must form a solid foundation that combines intelligent network platforms with sound management principles and a well-engineered information infrastructure. With this foundation, DISA can capitalize on new technologies while continuing to meet our rapid customer service and applications delivery requirements. Figure 1

depicts the overall transformed DSN concept and its role in the future telecommunications environment.

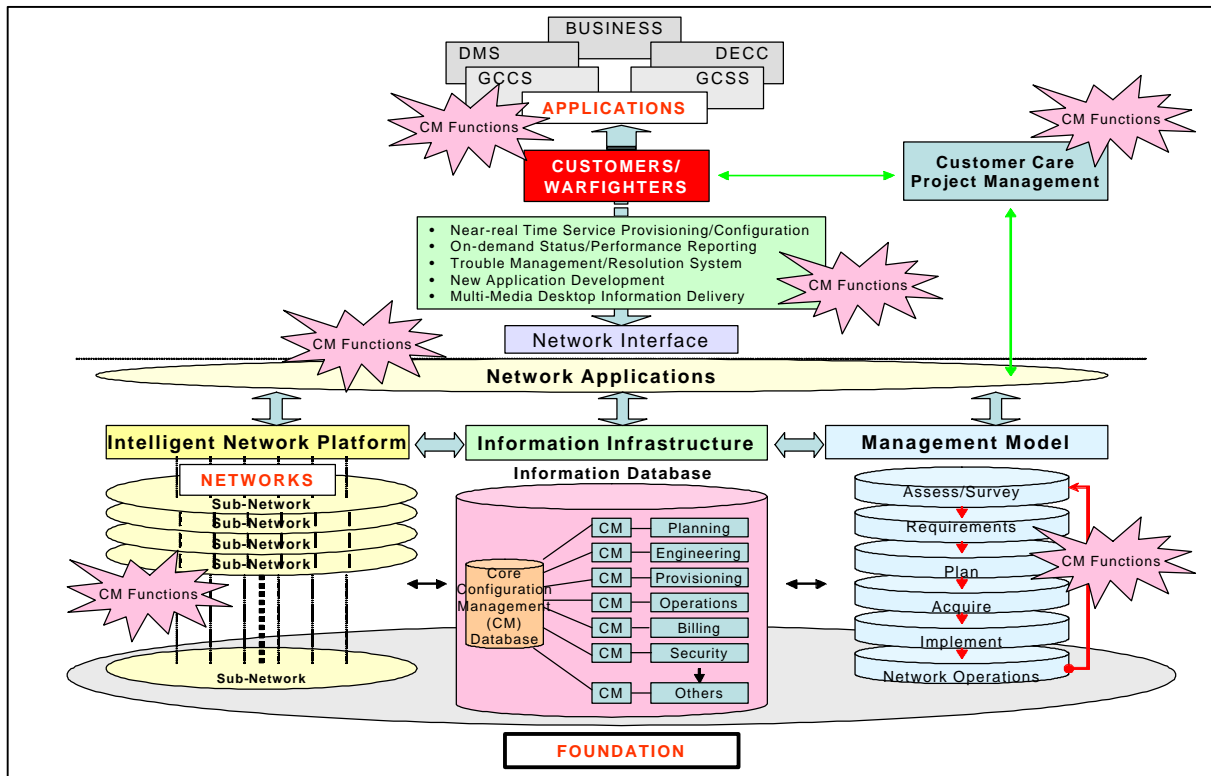

Figure 1 Transformed DSN Concept and Vision

As shown in Figure 1 the key element that integrates all entities within the foundation under DISA’s control as well as those entities external to DISA is Configuration Management (CM). Without CM it is almost impossible to satisfy performance requirements. Therefore DISA is constantly looking to improve its CM capability. The criticality of good CM becomes most obvious in tension-crisis situations where system elements must be quickly adjusted or deployed with high reliability in an unstructured situation. Much time and performance is saved when the field forces “get it right the first time”.

This paper will articulate how CM will be applied in support of the vision for long-haul inter-switch circuit switched services and end-to-end Command and Control circuit switched services.

2.0 Current System Description

DSN consists of multiple systems and sub-systems that represent voice circuit switches (Multifunction Switches and End-office Switches), transmission facilities, timing and synchronization, signaling, operation centers, integrated network management systems, various software and hardware components, and customer premises equipment. It interconnects with the Military Department's (MILDEP's) base/post/camp/station facilities to provide inter-base communications. Refer to Figure 2 below.

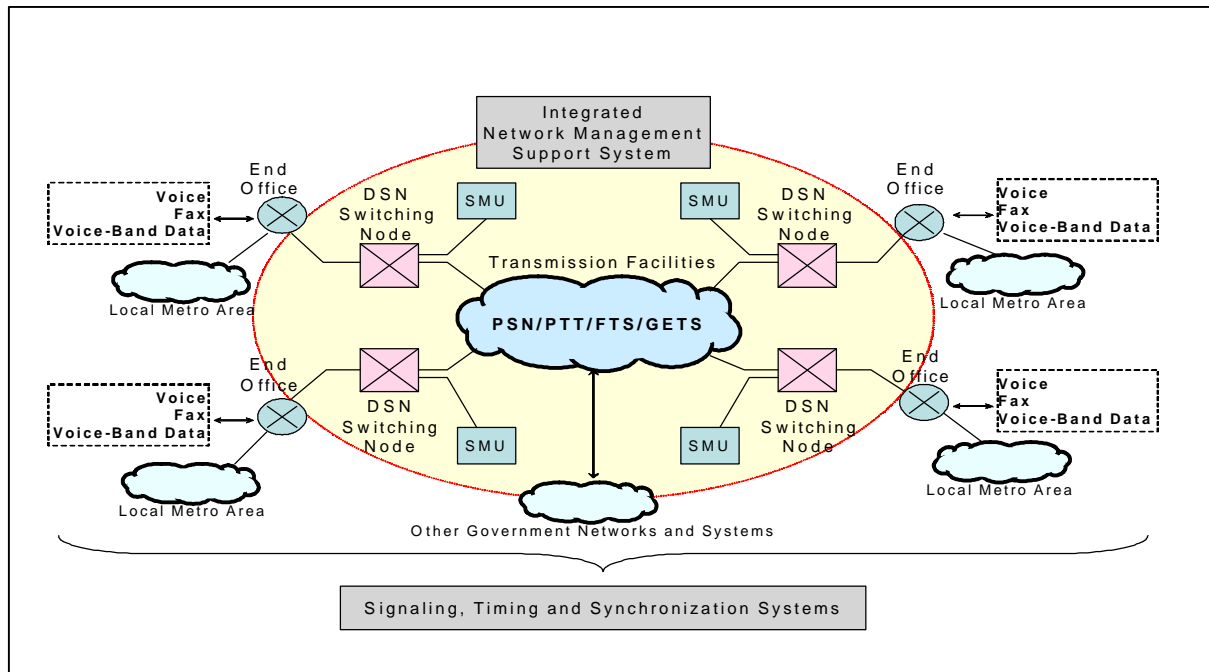

Figure 2 Defense Switched Network (DSN) System Overview

Due to the diverse geographical locations, DSN is further separated into four operating Theaters: WESTHEM (including Continental US (CONUS), Puerto Rico, the Azores, and Iceland), Pacific (including Alaska), Europe, and CENTCOM (previously Central Area/Southwest Asia). Due to the unique environments, the network within each Theater consists of different vendor hardware, software, operating procedures, and support systems.

3.0 Approach/Solution

Defense Switched Network (DSN) Configuration Management is the technical and administrative process used to identify and document functional and physical characteristics of the DSN network. CM also controls changes to those characteristics, records, and reports on change processing. CM ensures that proposed changes to the network's configuration are reviewed and approved by management before implementation. Once implemented, network changes are confirmed and recorded. This process helps ensure the baseline network are efficiently managed and network data is accurately presented to support other network management functions i.e. fault management, performance management, accounting management, and security management.

Because CM data form the basis to support other Network Management functions, it is most critical to have a common set of tools and automated system support to ensure CM data is maintained and shared amongst all the functional groups. In addition, interface agreements and procedural guidelines (Practices and Procedures, P&P's) must be established to guide the day-to-day operation of the DSN.

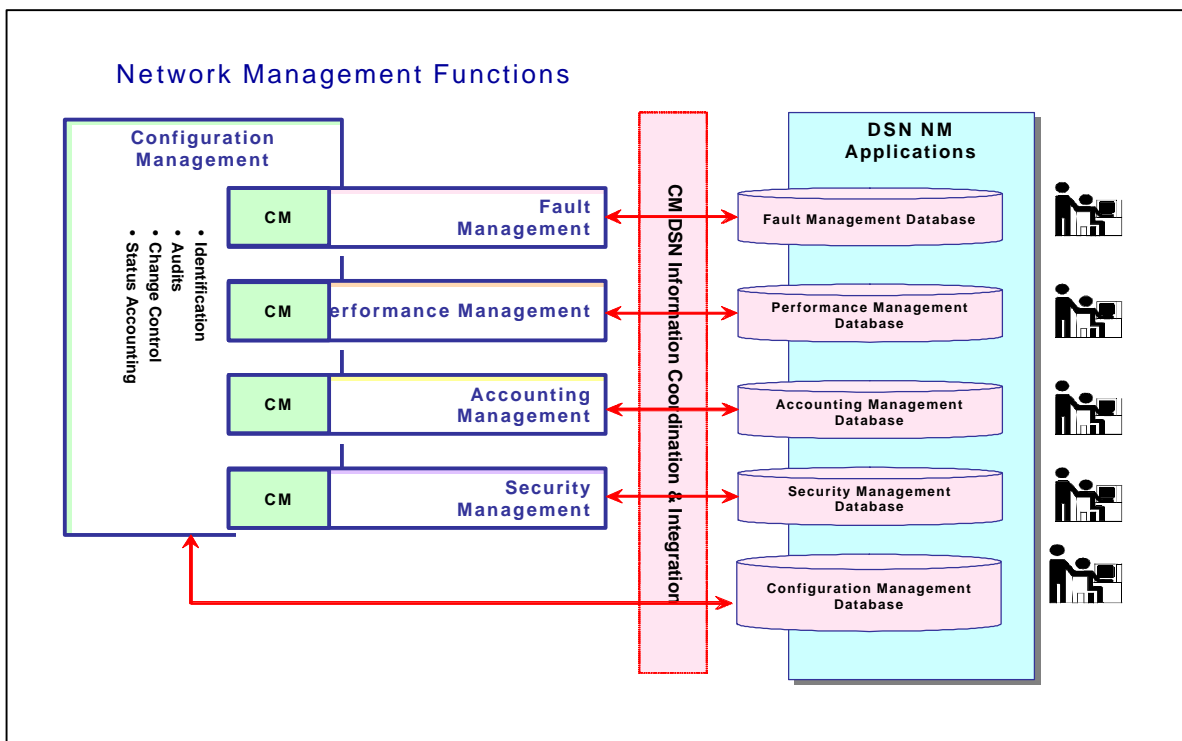

Figure 3 Network Management/CM Information Integration

To combat the challenges that DSN faces, a systematic approach is required to model the current DSN functions and activities and document/analyze its existing processes. This will help to establish an overall operational concept; determine process re-engineering; generate automated system support and Practices & Procedures enhancement requirements. Figure 4 illustrates this approach.

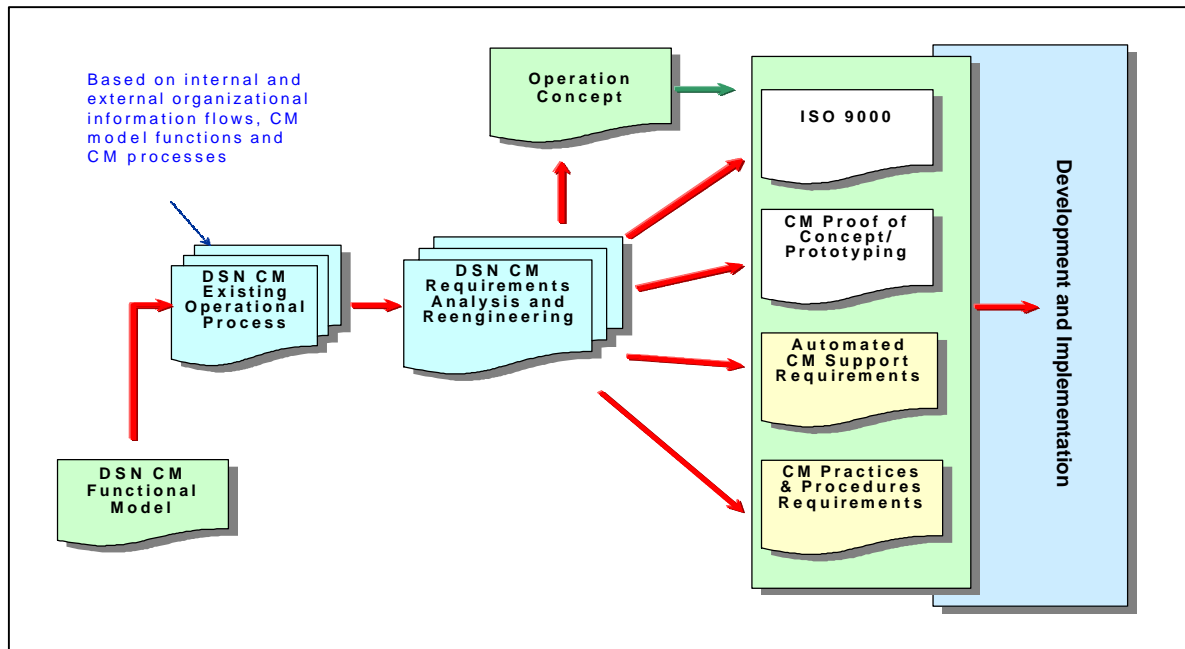

Figure 4 DSN CM Approach

The current DSN implementation must be captured and analyzed to form a System Model. This system model provides a blueprint of the DSN functions to include management, planning, engineering, provisioning, and operations. The associated processes within DSN and support systems must also be documented and analyzed. The analysis of current DSN processes and support systems will help to determine the user and automated support system requirements, as well as to identify immediate improvements. The current DSN system model will reveal the network elements necessary to operate and manage the DSN as a whole as well as its theater specific requirements. The network elements will include all the critical network components needed to provide services to the user community.

An over all DSN CM Operational Concept that is independent of hardware, software and network restrictions must be formed to meet the users' requirements. The current/existing database systems must be compared to this Operational Concept and network element requirements resulting from the DSN modeling. This will allow the formation of implementation priorities and phase-in approaches that lead to database integration and standardization while minimizing the impact on existing operations.

4.0 DSN CM Functional Model

The DSN management model for CM comprises of functional layers that are tailored to Department of Defense (DOD) voice services and networks. The DSN CM Model is developed using information from DOD standards and guidance, as well as commercial industry standards and practices, these including:

- ❑ DOD, Military Handbook for CM (MIL-HDBK-61a)
- ❑ DSN Configuration Management Plan
- ❑ ISO/OSI Basic Reference Model for Network Management
- ❑ Telestrategies, Operational Support System – Functional Matrix
- ❑ ITU-T, Telecommunications Management Network (TMN)

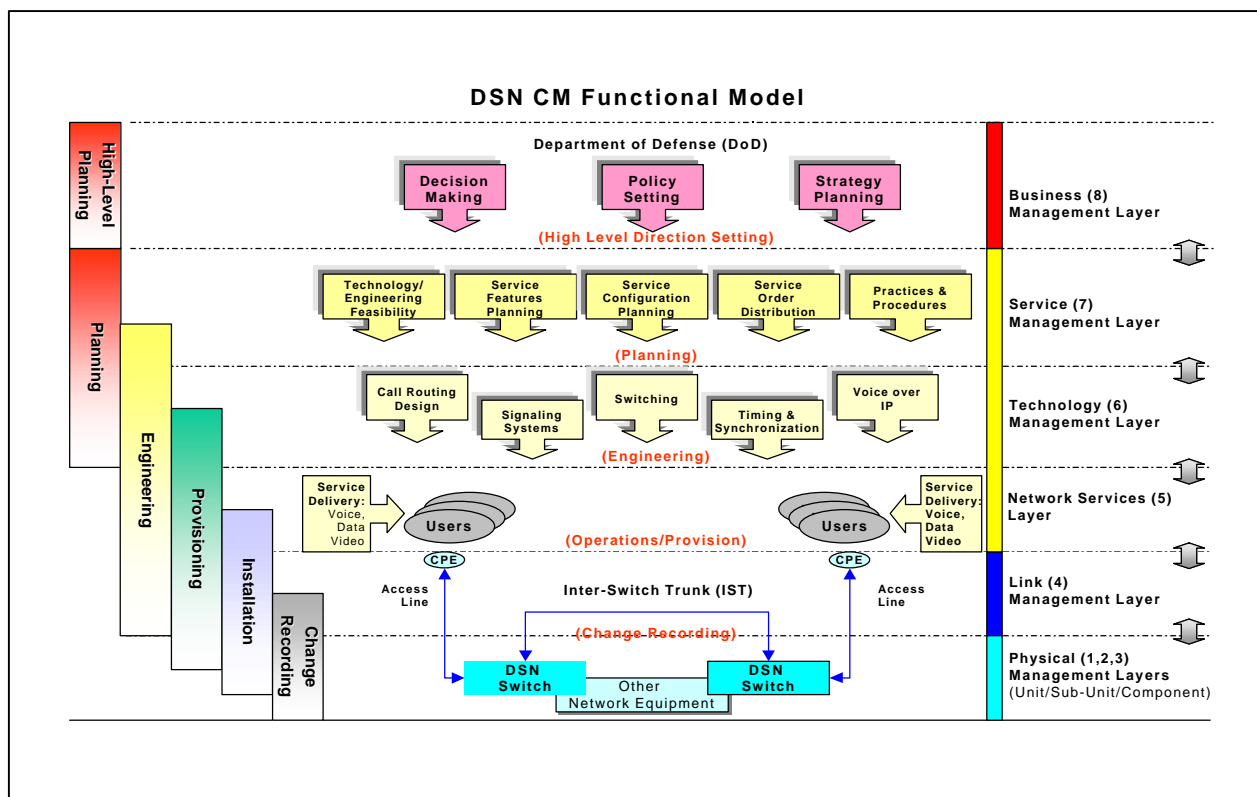

Figure 5 DSN CM Functional Model

The 8-layer model focuses on the Management Functions of DSN Configuration Management:

Layer 8: The **Business Management Layer** represents the highest layer where all high-level decisions and strategies are being made.

Layer 7: The next layer of **Service Management Layer** provides additional feasibility planning of the DSN technologies, configurations, service features, and P&P's.

Layer 6: Detailed system engineering functions are being done at the **Technology Management Layer** where items such as Call-routing designs, Signal and

Timing/Synchronization systems, and other transport and switching technologies are being engineered.

Layer 5: The *Network Services Layer* focuses on the end-to-end delivery of DSN services (voice, data, and video) to the end-users.

Layer 4: The *Link Management Layer* provides the management functions for Inter-Switch Trunks (IST) and access lines that are providing transport the DSN services.

Layer 3/2/1: Each of the lowest three layers (*Physical Management Layers*) are dedicated to the functional management of Physical Unit (PU, Layer 3), Physical Sub-unit (PSU, layer 2), and Physical Component (PC, Layer 1).

These eight (8) layers represent the transitioning of Planning (at higher levels), Engineering, Provisioning, Installation, and Operations/Change Recording (at lower levels) within the DSN Configuration Management structure. There are two-way interactions between each layer and most interactions are from top down (i.e. from a higher layer to a lower layer).

4.1 Model Comparison

The DOD Military Handbook for CM addresses the procurement and configuration management standards for weapon systems. It does not offer a configuration management reference model. The DSN CM Functional Model incorporates the functionality from the DSN CM Plan and Handbook, along with other functions from the ISO (OSI Model), ITU-T (TMN Model), and Telestrategies (OSS).

The OSI Basic Reference Model addresses the interconnection and communication of an open system. The DSN CM Functional Model focuses on the various configuration management functions that are specific to Defense Switch Network (DSN). The OSI Model deals with the open system's software, hardware, and application. Therefore, the OSI model can only be related to the DSN's first five layers (i.e. from Physical Layer up to Network Services layer). The remaining DSN CM Functional Model management layers (Network Technology, Service, and Business) are not covered by OSI.

The ITU-T model is the Telecommunications Management Network (TMN) model. This ITU-T standard is used for managing telecommunications networks and the services they provide. The DSN CM Functional Model resembles the TMN management model.

4.2 Description of Layers within the DSN CM Functional Model

The table below provides a detail description on each of the eight functional layers within the DSN CM Model:

Layers		Functions					Example
		Planning	Engineering	Provisioning	Installation	Change Recording	
8	Business Management	<i>Layer 8: Business Management Layer</i> The management of high-level direction setting for DSN services.					Planning of strategy, policy, and decision making
7	Services Management	<i>Layer 7: Services Management Layer</i> The management of service planning on technology, configuration, and customer-focused services.					Planning of technologies features, & ordering
6	Technology Management	<i>Layer 6: Technology Management Layer</i> The management of technology and engineering in order to deliver DSN services at the lower DSN CM functional layers.					Engineering & design of routing, signaling, switching
5	Network Infrastructure	<i>Layer 5: Network Services Layer</i> The management of DSN services (switched voice, voice-band data, and video). This layer represents the operations and end-to-end service delivery to the users.					Operation of Switched voice, data, and video services
4	Link Management	<i>Layer 4: Link Management Layer</i> The management of Link, or connectivity, between physical layers. This could be the transmission facilities/circuits that connect two DSN switches, or access lines that connect the user's CPE to the DSN.					IST's and Access Lines
3	Physical Unit Management	<i>Layer 3: Physical Unit Management Layer</i> The management of a physical configuration unit (hardware/software). This represents the highest level within the three <i>Physical Layers</i> .					DSN Switch, ATM Switch, and PBX
2	Physical Sub-Unit Management	<i>Layer 2: Physical Sub-Unit Management Layer</i> The management of sub-unit (hardware/software) within a physical configuration unit.					DSN Switch's Trunk Module
1	Physical Component Management	<i>Layer 1: Physical Component Layer</i> The management of the lowest-level physical configuration item (hardware/software) i.e. components within a unit or sub-unit. This represents the lowest level within the three <i>Physical Layers</i> .					DSN Switch's Trunk Card

Table 1 DSN Functional Model

5.0 Operational Concept

The critical element of this operational concept is having a common DSN database with a core database structure which allows access by all CM functions. This will allow a standard process of evaluation/recommendation/approval prior to implementing the network changes. Once the changes are implemented, they will be uniquely identified, audited, and stored within the DSN Core CM Database.

Figure 6 illustrates the proposed DSN CM Operational Concept.

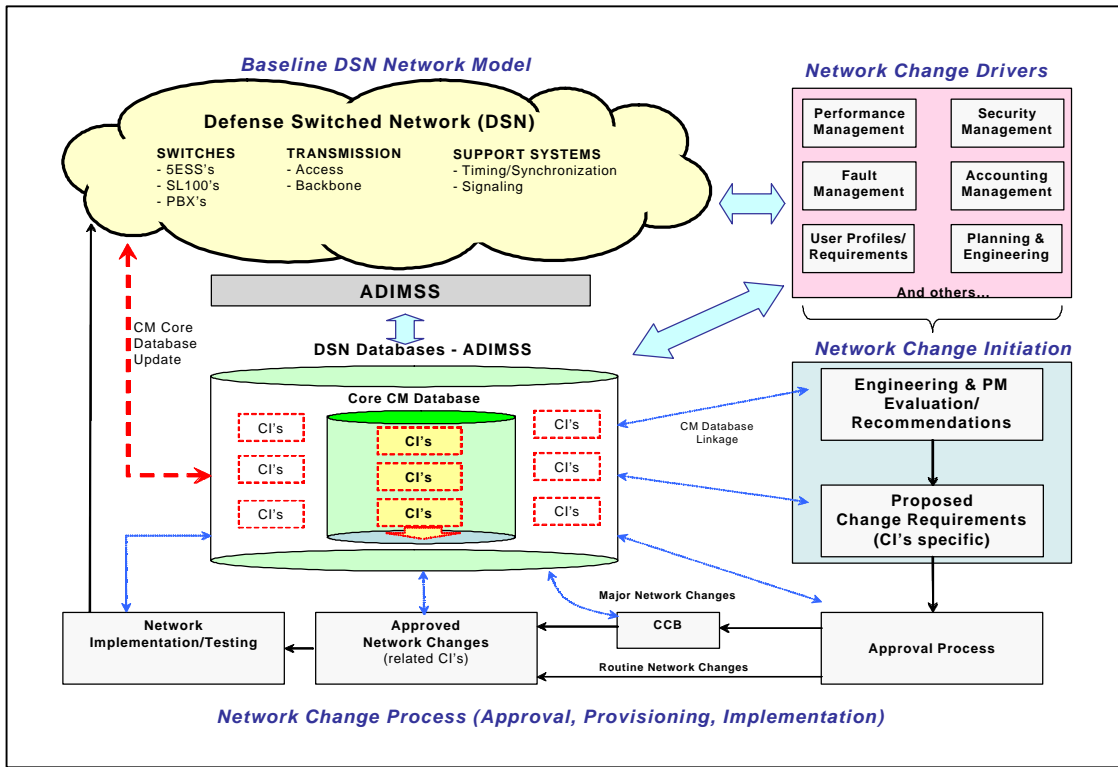

Figure 6 Proposed DSN CM Operation Concept

5.2 DSN CM Database System

The DSN database will provide system interfaces to other existing DSN support systems such as network requirement ordering, provisioning, engineering, planning, accounting, management, and other administration systems. This will facilitate the information sharing necessary to support the CM processes of identification, audit, change control, and status accounting. Figure 7 shows the DSN CM operation concept with the automated support systems.

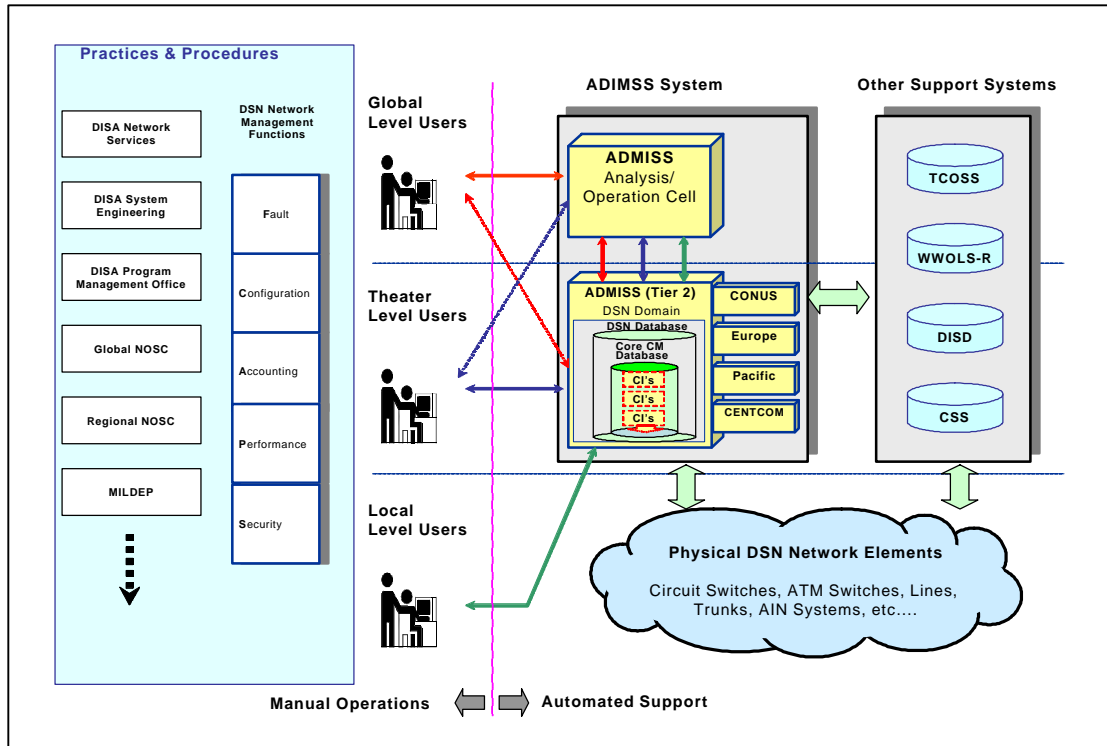

Figure 7 Overall DSN CM Operational Concept

Establishing a DSN CM Database with a core database structure is the critical path in building a successful DSN CM Program. The core CM database contains only the installed and operational DSN network elements, and it provides the support for the automated CM support systems and other DSN support systems.

DSN Configuration Management users include Management, Operations, Maintenance, Engineering, and Administration personnel. These users can be located locally (MILDEP), within each Theater, or at the Global level. Users at multiple levels and locations can access this core database structure to perform various DSN functions.

System interfaces must be provided to share and exchange information with other DISA systems such as Telecommunications Certification Office Support System (TCOSS), World-Wide On-Line System Replacement (WWOLS-R), Defense Information System Database (DISD), and Contract Support System (CSS) that are critical to the DSN operations. Users can rely on the automated support system to support their daily operations such as network/traffic engineering, planning, cost accounting, etc....

Advance Defense Switched Network Integrated Management Support System (ADIMSS) will provide a platform for all database functions and automated support necessary for DSN CM. While there are various system applications that support individual DSN function (i.e. financial/accounting, planning/engineering, provisioning/installation, etc...), the core CM database within ADIMSS will provide the central data depository for the critical Configuration Items (CI's) that are common to all DSN functions. Within the DSN domain, the core CM

database tracks all critical Configuration Items (CI's) that are common to other DSN databases and support systems. The common CM database structure applies across all theaters (CONUS, Europe, Pacific, and CENTCOM). This will allow interoperability and accessibility at the global level.

The following is an example of the DSN CM Database levels and their CI's:

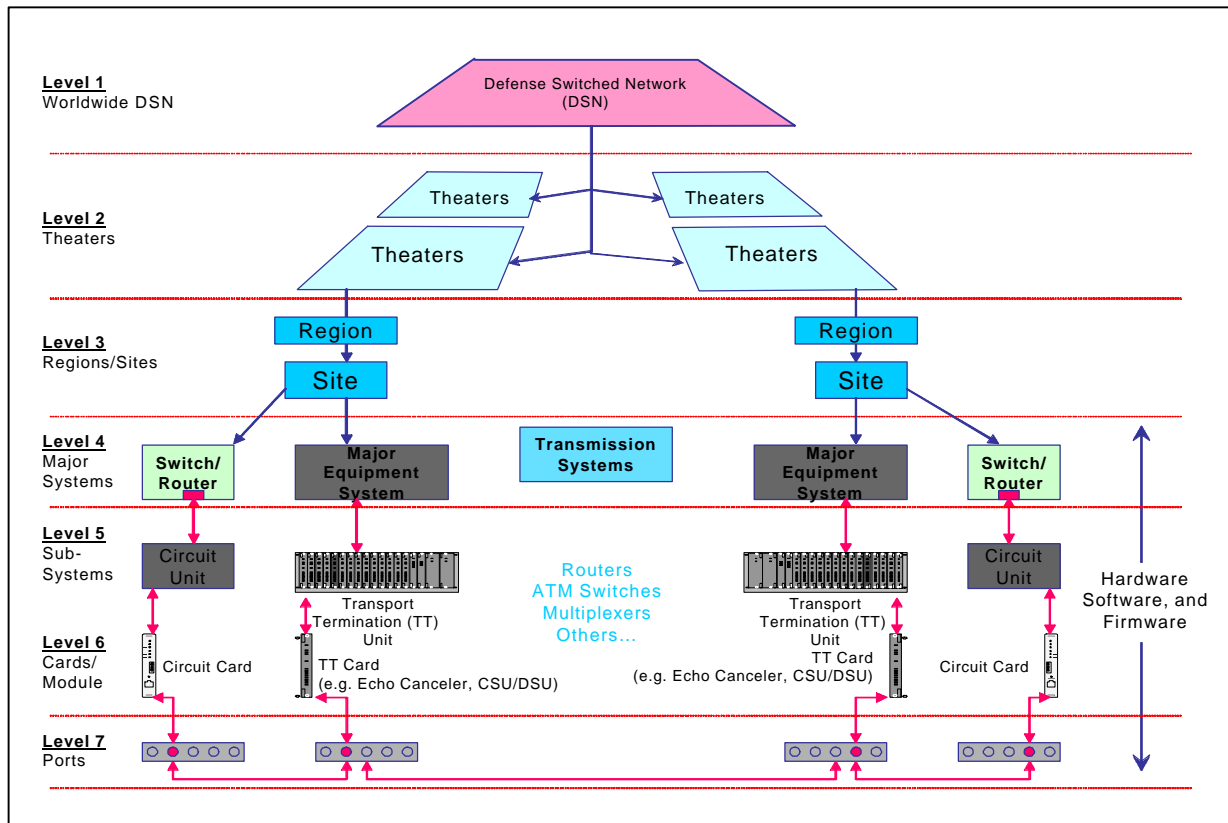

Figure 8 DSN CM CI Levels

DSN CM users at different levels (i.e. Global, Theater, and Local levels) can access the core database and data mart to perform their specific tasks (i.e. performance management and fault management). The overall ADIMSS/CM Database Administrator will control user access to data that is outside of their level.

The core DSN CM Database should include configuration items from the following major components:

- DSN Switch Hardware and Software
- Transmission Equipment
- Signaling Systems (SS7/STP)
- Trunk Circuits (Inter and Intra Theater)
- Network Financial and Cost Information

Figure 9 depicts the DSN CM Database System Operational Concept.

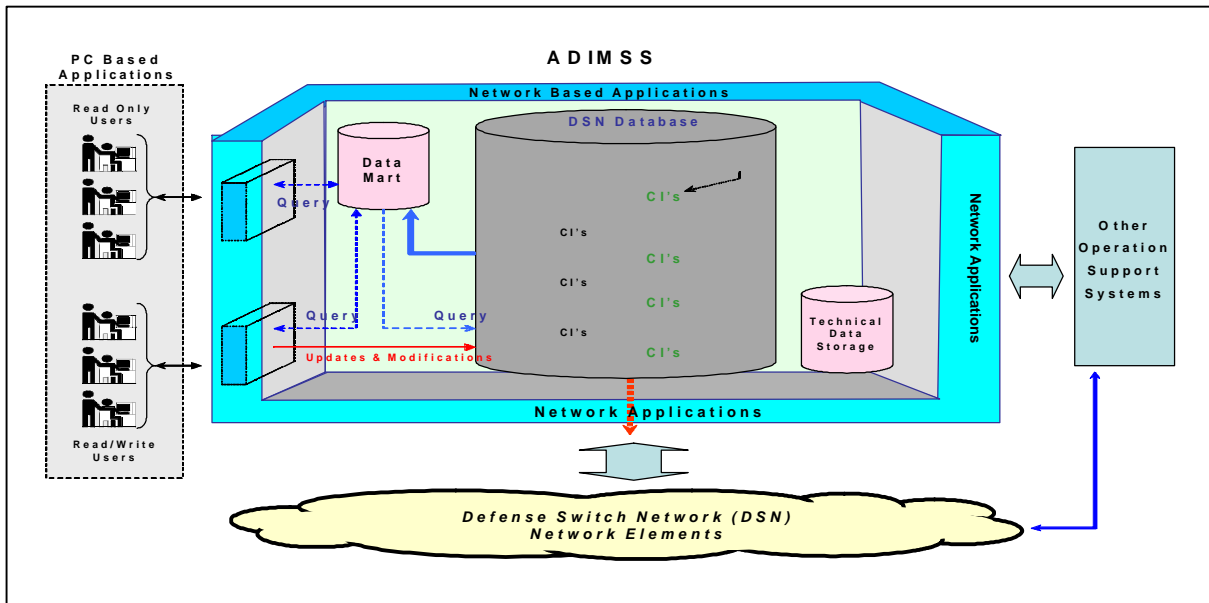

Figure 9 DSN CM Database Operational Concepts

The Technical Data Storage (TDS) will support all on-line CM requirements such as storage of technical specifications, network routing information, Practices & Procedures, and other information that is not associated with the operational plant (e.g. non-core/planned implementation). The Data Mart will allow users to store data from multiple sources, including the core database, and customized data for their specific applications.

Figure 10 depicts an example using Inter-Switch Trunks (IST's) as network elements (or configuration items) that are being tracked by the DSN CM database to store its connectivity and relationships between the CI's.

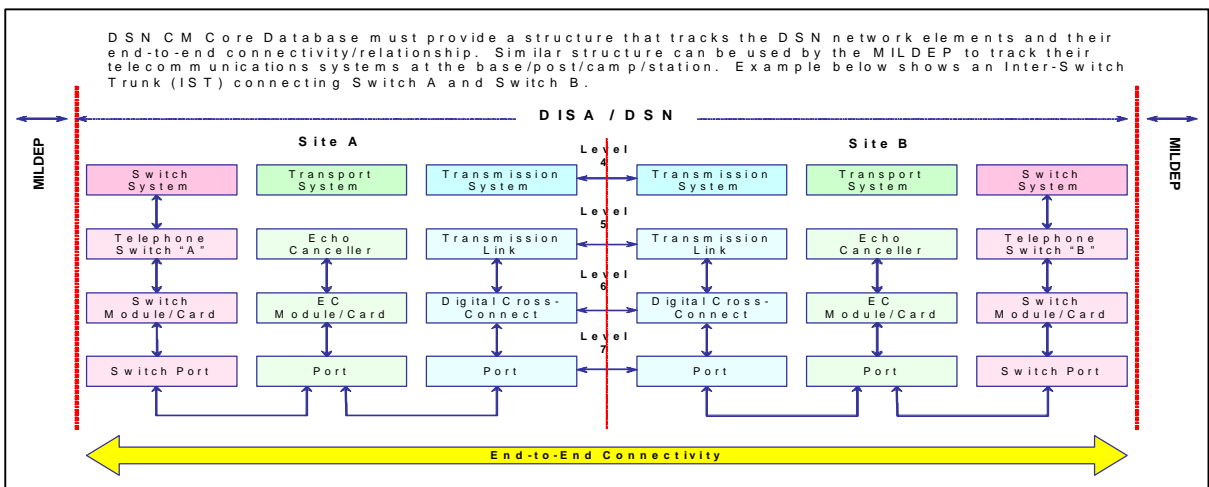

Figure 10 Example of DSN CM Database CI Levels for an Inter-Switch Trunk (IST)

6.0 Summary of Current Status & Implementation Plan

Implementation of the above Operational Concept and Core Database Structure must be carefully planned and program managed. It must minimize the impact on the existing operational network and network management systems.

Currently, the DSN CM functional model is completed. Existing operational processes are documented and being analyzed. A list of the immediate initiatives that will improve the short-term DSN operations was provided. A proof of concepts is completed on the automated DSN topology tracking based on a common database of network elements (DSN voice switches and trunks). The documentation of automated support system and Practices/Procedures (P&P) requirements are completed. Likewise, the initial requirement to establish a level structure for the Configuration Items (CI's) within the DSN database is completed.

The following is a list of the overall program activities:

□ CM Requirements

- A. Model Development
- B. Process Development
- C. Automated Support requirements
- D. P&P Requirements

□ Operational Concept

- A. Operational Concept Creation
- B. Documentation of Operational Concept

□ Proof of Concept

□ Automated CM Support System Architecture

- A. System Architecture Creation
- B. Documentation of System Architecture

□ CI Development

- A. Identify CIs
- B. CI Levels
- C. Establish Baseline
- D. Derive Data Elements
- E. Develop CM Data Dictionary
- F. Database Sizing

□ Core Database Prototype

- A. CM Requirements
- B. Determine Baseline Network
- C. System Design
- D. System Development
- E. Data Collection
- F. Data Population
- G. Data Verification
- H. System Testing
- I. System Debugging
- J. System Operation
- K. Feedback/Documentation

□ User Support Requirements

□ DSN Configuration Control Board Support

□ Automated System Development P&P Development