

1. Topic: C2 Decision Making & Cognitive Analysis
2. Title : **Integration of Information Operations into Effects-Based Operations:
Some Observations**
3. Author: **Larry K. Wentz and Lee W. Wagenhals**
4. Organization: C3I Center, George Mason University
5. Address: System Architectures Laboratory
C3I Center, MSN 4B5
George Mason University
Fairfax, VA 22030-4444

Larry Wentz
703-993-1725 (v)
703-993-1706 (f)
lwentz@bellatlantic.net

Lee W. Wagenhals
703-993-1712 (v)
703-993-1706 (f)
lwagenha@gmu.edu

6. POC: Larry K. Wentz

Report Documentation Page

Form Approved
OMB No. 0704-0188

Public reporting burden for the collection of information is estimated to average 1 hour per response, including the time for reviewing instructions, searching existing data sources, gathering and maintaining the data needed, and completing and reviewing the collection of information. Send comments regarding this burden estimate or any other aspect of this collection of information, including suggestions for reducing this burden, to Washington Headquarters Services, Directorate for Information Operations and Reports, 1215 Jefferson Davis Highway, Suite 1204, Arlington VA 22202-4302. Respondents should be aware that notwithstanding any other provision of law, no person shall be subject to a penalty for failing to comply with a collection of information if it does not display a currently valid OMB control number.

1. REPORT DATE JUN 2003		2. REPORT TYPE		3. DATES COVERED 00-00-2003 to 00-00-2003	
4. TITLE AND SUBTITLE Integration of Information Operations into Effects-Based Operations: Some Observations				5a. CONTRACT NUMBER	
				5b. GRANT NUMBER	
				5c. PROGRAM ELEMENT NUMBER	
6. AUTHOR(S)				5d. PROJECT NUMBER	
				5e. TASK NUMBER	
				5f. WORK UNIT NUMBER	
7. PERFORMING ORGANIZATION NAME(S) AND ADDRESS(ES) George Mason University, System Architecture Laboratory, C3I Center, MSN 4B5, Fairfax, VA, 22030-4444				8. PERFORMING ORGANIZATION REPORT NUMBER	
9. SPONSORING/MONITORING AGENCY NAME(S) AND ADDRESS(ES)				10. SPONSOR/MONITOR'S ACRONYM(S)	
				11. SPONSOR/MONITOR'S REPORT NUMBER(S)	
12. DISTRIBUTION/AVAILABILITY STATEMENT Approved for public release; distribution unlimited					
13. SUPPLEMENTARY NOTES The original document contains color images.					
14. ABSTRACT					
15. SUBJECT TERMS					
16. SECURITY CLASSIFICATION OF:			17. LIMITATION OF ABSTRACT	18. NUMBER OF PAGES 35	19a. NAME OF RESPONSIBLE PERSON
a. REPORT unclassified	b. ABSTRACT unclassified	c. THIS PAGE unclassified			

Information Operations in Effects Based Operations: Some Observations¹

Larry K. Wentz, Lee W. Wagenhals

<lwentz><lwagenha>@gmu.edu

C3I Center, George Mason University

Fairfax, Virginia 2203-4444

Abstract

Information Operations (IO) has become a primary war fighting capability and is now considered a military core competency. The military Services are establishing IO as a military career field equivalent to other war fighting fields and they are developing supporting education and training programs to create a pipeline of trained and experienced information operations warriors. Transforming doctrine into an operational reality has, however, proven to be a challenge and the training programs and operational planning and assessment tools have been slow to materialize.

Operations in the Balkan's and Afghanistan have afforded the military the opportunity to conduct IO and to document experiences and lessons from these real world operations. A number of experiments and exercises also have explored new military concepts that included the use of non-kinetic IO means of national power to influence adversary behavior and actions. This paper explores some of the challenges of executing and assessing IO courses of action including some observations regarding integration of IO into EBO. The insights and observations offered are based on the authors multiple experiences. Operationalizing IO is work in progress and much remains to be done to bridge policy, doctrine, applications and tools.

Introduction

Information Operations (IO) is now considered a military core competency. The military Services are establishing IO as a military career field equivalent to other war fighting fields and they are developing supporting education and training programs to create a pipeline of trained and experienced information operations warriors. As a primary war fighting capability, a number of doctrine, procedure and organization initiatives are also underway to operationalize IO. Transforming doctrine into an operational reality has, however, proven to be a challenge and the training programs and operational planning and assessment tools have been slow to materialize. Recent real world operations in the Balkan's, Afghanistan, and Iraq have afforded the military the opportunity to actively conduct IO and to document experiences and lessons from these real world operations that can be used to facilitate the transformation. A number of experiments and exercises have also started to address the use of IO as an instrument of national power. For

¹ This work was supported by the Office of Naval Research under grant No. N00014-00-1-0267 and by the Air Force Office of Scientific Research under grant No. F49620-02-1-0332

example, in the Summer of 2002, the Joint Forces Command (JFCOM) sponsored the joint experiment Millennium Challenge 2002 (MC02) that explored new military concepts for future operations that included the use of non-kinetic IO means of national power to influence adversary behavior and actions. Two of the key concepts tested during MC02 were Rapid Decision Operations (RDO) and Effects Based Operations (EBO), a new way of thinking about engaging the enemy that provides an alternative to traditional attrition-based warfare planning, execution, and assessment.

EBO emphasizes a comprehensive understanding of the adversary as a complex, adaptive “system-of-systems” and examines the causal linkages and effects through which military and nonmilitary actions lead to obtaining the desired outcome or effect. Since IO can be used to attack not only the adversary’s systems but also the mind of the opponent and therefore, shape the adversary’s opinions, behavior and decisions, a challenge faced by military forces is the integration of IO into EBO courses of action.

A brief high level overview (references 4, 7, 8, and 9) of several of the RDO key enabling concepts (i.e., EBO, ONA, and CIE) follows as background for a discussion of some of the challenges of executing and assessing IO courses of action including some observations regarding integration of IO into EBO. The paper concludes with thoughts about future directions. The insights and observations offered herein are largely based on the authors’ multiple operational experiences. Operationalizing IO is work in progress and much remains to be done to bridge policy, doctrine, applications, and tools. A companion GMU paper discusses the use of its CAESAR II/EB tool to support IO course of action planning and assessment.

Rapid Decisive Operations

The Joint Forces Command (JFCOM)-sponsored joint experiment Millennium Challenge 2002 (MC02) explored the military’s ability to conduct Rapid Decisive Operations (RDO) against a determined adversary where RDO included the use of non-lethal means such as those contained within the IO suite of actions (e.g., PSYOP use of leaflet drops and Commando Solo radio and TV broadcasts). For the experiment, JFCOM defined RDO as follows (reference 9):

Rapid Decisive Operations is a joint operational concept for future operations. A rapid decisive operation will integrate knowledge, command and control, and effects-based operations to achieve the desired political/military effect. In preparing for and conducting a rapid decisive operation, the military acts in concert with and leverages the other instruments of national power to understand and reduce the adversary’s critical capabilities and coherence. The United States and its allies asymmetrically assault the adversary from directions and in dimensions against which he has no counter, dictating the terms and tempo of the operation. The adversary, suffering from the loss of coherence and unable to achieve his objectives, chooses to cease actions that are against US interests or has his capabilities defeated.

The RDO concept is based on first attempting to influence and deter the adversary. At the national and theater levels, the diplomatic, information, and economic instruments of national power, supported by relevant military flexible deterrent options, would be employed before considering the use of a broader range of national capabilities. If deterrence fails, then the broader range of national power, including military force, would be employed rapidly and decisively to coerce, compel or defeat the enemy.

A number of enabling functional concepts (references 4, 7, and 8) helps set the military conditions for conducting RDO. One of the key functional concepts is Effects Based Operations (EBO), a new way of thinking about engaging the enemy that provides an alternative to traditional attrition-based warfare planning and assessments. EBO emphasizes a comprehensive understanding of the adversary as a complex, adaptive “system-of-systems” and examines the causal linkages and effects through which military and nonmilitary actions lead to obtaining the desired outcome or effect. Unintended outcomes are examined as well. The integration of IO into EBO provides the commander a flexible means to manipulate, influence or control an adversary’s will, perception and understanding and make him ineffective in his ability to act or react.

Other important functional RDO concepts are the Operational Net Assessment (ONA provided the foundation for a coherent knowledge base that enables EBO and requires an understanding of both adversary and friendly as a set of independent systems—Political, Military, Economic, Social, Infrastructure and Information), the Collaborative Information Environment (CIE included a fully networked force, Common Relevant Operational Picture and collaboration tool suite), improved Interagency collaboration (JIACG—Joint Interagency Coordination Group), the Standing Joint Forces Headquarters (SJFHQ enables seamless planning and operations), and Joint Intelligence, Surveillance, and Reconnaissance (JISR is a network-centric approach to ISR platform management).

To fully exploit RDO, a CIE should be built as a coherently joint C4I system that networked the knowledge and decision centers, such as the combatant command headquarters, the JTF and components, and external agencies. A comparable real world capability is CENTCOMs coalition wide area network, CENTRIX, which was used to support Operation Enduring Freedom and provided a coalition information environment that facilitated collaboration, coordination and information sharing among the coalition partners. The Joint en route mission planning and rehearsal system – near term (JEMPRS-NT), a joint airborne collaborative planning capability, can be employed as an integral part of the CIE and allow the JTF commander to continue to participate in the collaborative environment (capabilities such as VTC, intelligence updates, streaming video, chat rooms, collaborative planning and execution) from remote locations.

GMU Team and the CAESAR II/EB Tool

A prototype system to assist in developing EBO Courses of Action (COAs) that include non-lethal means and evaluating them in terms of the probability of achieving the desired effects has been developed by the George Mason University (GMU) C3I Center and is called CAESAR II/EB. Two of the key components of the system are: (a) an Influence net modeler such as the Campaign Assessment Tool (CAT) developed at AFRL/IF, and (b) an executable model generator and simulator based on the software

implementation of Colored Petri nets called Design/CPN. The CAESAR II/EB tool is used to simulate the COAs and collect data on Measures of Performance (MOPs). One particular output is the probability of achieving the desired affect as a function of time. The probability profiles generated can be used to help identify unintended consequences of proposed actions and can be compared to determine the more effective COAs.

GMU has experience with using the GMU tool suite in the Naval War College Global 2000 and 2001 war games and MC-02 in support of Blue's "Red Cell" In each case, the intent was to examine the use of CAESAR II/EB to support EBO COA planning and assessments in support of the JTF HQs staff. In these war games and experiments, the GMU team has worked with Blue's "Red Cell" and the Effects Assessment Cells to build several models that included an Intelligence & Warning indicator model for a possible rogue force attack on Blue forces, a model related to a possible chemical disaster resulting from rogue force use of WMEs, and several other models that looked at possible rogue force COAs in response to an attack by Blue forces. In each war game and experiment, Information Work Space (IWS) workstation was the key access to the collaborative planning and the information-sharing environment. It provides the team the ability to actively participate and continuously monitor briefings, chat rooms, and planning conferences that related to the operation in general and the IO Plans Cell activities in particular. To effectively use its tool, the GMU team had to collect the data and insights related to planning and operations activities, the concepts and tools being tested, and to search databases for information to construct the CAESAR models developed.

One of the clear lessons noted throughout our participation is that in order to participate effectively in any future war game or experiment, any team that is introducing Effects Based Course of Action technology should be engaged early on including the planning phases and in particular, the development of databases and related effects assessments and should be included as a full member of the organizational element to which it is assigned for a future experiment or exercise.

Participation in these war games has been both challenging and rewarding, and the team members viewed the participation as a worthwhile exercise. There were positive learning experiences. It was felt that the GMU team was able to contribute in a modest way to each event. The team also gathered a great deal of insights about the integration of IO into EBO and the use of a CAESAR-like tool in the theater and tactical environment. The use of the collaborative information environment to support IO course of action planning and assessments was a useful experience as well.

Discussion

The information age has changed the way the military organize, train, and fight. Advanced information technology offers the opportunity to improve the ability to achieve information superiority to reduce the fog and friction of crisis and warfare. Information superiority facilitates military execution of rapid decisive operations that employs all elements of national power to achieve national policy objectives. RDO enabling concepts such as EBO are a way of thinking and systematically planning, executing and

assessing operations designed to attain specific effects through a cohesive and synergistic application of military and non-military means. Therefore, in order to take full advantage of the RDO and EBO concepts and processes, the planners and decision makers of the future must begin to think in terms of what it is they are trying to accomplish and the actions that might need to be taken and develop the tools necessary to enable them to more effectively plan and assess how well the proposed actions contribute to achieving the desired effect. To make this transformation, however, the military needs to significantly improve the level of interoperability and synergy in the areas of doctrine, organization, training, material, leadership and education, personnel, and facilities (DOTMILPF).

In the authors' view, the military have characterized and analyzed war games, experiments, exercises and real world operations as force-on-force. The friendly and adversary strengths and vulnerabilities of the attrition-based domain are understood and the military and infrastructure is modeled reasonably well. Additionally, the deliberate and crisis action planning process that supports military operations is largely attrition based as well. Some challenges arise when excursions, such as those set forth in the RDO concept, are made to consider employment of means other than military power. Here the strengths and vulnerabilities and interactions and relationships between Political, Military, Economic, Social, Infrastructure, and Information (PMESII) centers of gravity seem to be less well understood and there are few models and processes that support effects based planning and assessment of multi-disciplinary approaches to achieving national policy goals—the military comfort level tends to favor forceful actions, not changing the adversary's behavior by other means. In fact, the latter is harder to assess and model since the outcomes are more systemic, psychological and sociological rather than physical. To a hard kill, action-oriented military, soft PMESII effects that take long periods of time to be realized can add complexity and uncertainty to the willingness of the military to adopt and operationally employ diplomatic, information and economic means. In spite of some perceived resistance to change, the new world order driven by asymmetrical threats and globalization of information, has put into motion a military mind set change that appears to be more willing to incorporate new concepts and processes that address not only the use of the military power but other means of national power (DIME—Diplomatic, Information, Military, and Economic) to achieve the desired effects.

Some of the new military concepts, capabilities, and processes being pursued are reflected in the RDO, EBO, ONA, and other enabling concepts. Integration of new war fighting capabilities such as IO into EBO are being tested along with improved information environments such as the CIE that provided the Common Operational Picture (COP), the Common Relevant Operational Picture (CROP), and collaborative planning tools to facilitate information sharing, improved shared situation awareness, and enriched collaboration among users that were geographically and organizationally separated. A fully networked information-sharing environment enables the CIE.

It is the authors' view that significant progress was made in developing RDO and its enabling concepts. The SJFHQ, CIE and JIACG concepts are viewed by JFCOM (reference 4) as being nearly ready for prime time use. The SJFHQ and CIE are probably the most mature of the concepts and certainly can add value towards achieving RDO. The SJFHQ can facilitate the transition of the JTF headquarters element to operational status

and help reduce the ad hoc nature of JTF-HQs operations. The CIE provides an improved information sharing and collaboration environment that more effectively supports joint operational planning and execution. The JIACG helps coordinate interagency operational planning and provides the JTF commander and his staff the ability to access country, political, social and economic subject matter experts (SME) through the use of both reachback capabilities and collocated expertise. The challenge in this regard is tailoring the JIACG support mix to meet the needs of the JTF commander. Tailoring may require both SMEs collocated with the JTF staff and access to SMEs in other geographic areas through the use of reachback capabilities and the CIE to share information and conduct collaborative planning. In a real world operation, allies and world opinion, including the US internal political and public opinion, will also influence EBO planning and assessments.

Lt Col Ted Uchida, AF/XOCW, in his Military Operations Research Society (MORS) paper on analysis of effects based operations (see reference 14) points out that there are a myriad of definitions for the enabling functional concept EBO. He notes the US Air Force defines EBO as a methodology for planning, executing and assessing operations to attain the effects required to achieve desired national security objectives and that the MORS workshop on analyzing effects based operations terms of reference put EBO in the context of a strategy and operational framework that combines military operations with other elements of national power such as economic and political actions. Additionally, he noted that JFCOM J9 views EBO as a process for obtaining a desired strategic outcome or effect on the adversary through the synergistic and cumulative application of the full range of military and non-military capabilities at all levels of conflict, where effect can be physical, functional, or psychological outcome, event or consequence that results from specific military and/or non-military actions. A major challenge in implementing EBO is developing and assessing courses of action (including non-lethal means) and then predicting the likelihood of achieving the desired behavioral changes and/or effects over some period of time, especially in the face of friction, ambiguity, uncertainty and an adaptive adversary.

EBO provides insights into the challenges of changing the military thinking about the use of the full range of national power (including non-lethal means) to defeat an adaptive adversary by attacking the coherence of his centers of gravity—think effects. Because EBO is new and still under development, it is likely that it may not be fully understood by many of the JTF staff. This may mean that all capabilities are not effectively employed—largely attributed to training and education issues. ONA can provide the foundation for a coherent knowledge base that enables EBO by linking effects with nodes, actions, and resources and a tool suite for conducting system of systems analysis and visualizing effects of proposed actions. Use of the ONA remains somewhat of a challenge. New tools are needed to facilitate access and use of the database for analysis. Both the EBO and ONA concepts are worth pursuing as future capabilities but refinements are needed before the concepts would be ready for operational use.

IO is viewed as a significant combat multiplier but the bridge between policy, doctrine, and tactical application has yet to be fully refined. Hence, it is felt that IO and the integration into EBO needs improvements (reference 4) to meet operational expectations. Major short falls in this regard are modeling and simulation tools to help

assess the effects of IO and EBO actions. Additionally, from the authors observations, the visualization and presentation of IO and EBO effects for the JTF commander appeared to be a challenge for the staff. There is a need for more user-friendly tools to facilitate building influence nets, link and node assessment diagrams, conducting predictive assessments and trend analysis, and presentations for visualizing COAs and effect relationships. The ONA tool suite includes capabilities, such as, Verona, GENOA (included SIAM^{TM3}), Analyst's Notebook, and ArcView/ArcIMS. However, these tools are not widely used or understood by IO planners. As was experienced in other exercises and experiments, it is the authors' impression that the current tools are too cumbersome to use in the JTF operational environment—complex and manpower intensive. However, the tools have been used extensively to help build the ONA prior to the start of exercises. In addition, there are other tools that support visualization and analysis such as the IW Planning Capability, Global Command and Control System-Intelligence, Imagery and Information (GCCS-I3) and Automated Deep Operations Coordination System (ADOCS).

As was the case for real world operations in the Balkans, the war games and experiments have used elaborate PowerPoint briefings with creative icons, embedded pictures and images and detailed graphics for visualizing and sharing information, including intelligence. In Bosnia, staffs preparing these briefings were referred to as "PowerPoint Rangers." While the pictures were informative, there were few words documenting the information in the pictures. Many of these briefings were stored on the homepages and databases. A voice track or written description would have been very useful in getting a complete understanding of the message and points made in the briefing—this was not part of the information stored.

Another favorite simple visualization technique that has been used both in war games and the real world are the stop light chart (red, yellow or green) to illustrate progress or lack of progress and to identify and emphasize issue areas. Other icons such as arrows have been used in combination with words and other graphics to illustrate changes. For example, a down arrow could represent an element's shift to the negative and a horizontal arrow no change. Other charts that have been developed using the Analyst's Notebook to construct color coded node and link diagrams to illustrate connectivity and influence implications, e.g., political, terrorist and religious leader links with the adversary commander or 2nd and 3rd order effects related to taking a kinetic action to destroy infrastructure such as a power plant which as a second order effect may disrupt the regional water distribution and sanitization systems or local hospital operations. Identifying unanticipated and unintended consequences is an important EBO analysis consideration. Future JTF commanders can be expected to ask for an assessment of the 2nd and 3rd order effects of proposed actions.

The Collaborative Information Environment (CIE) demonstrates the utility of collaborative planning and information sharing and the ability to disseminate timely, fused and relevant information to establish and maintain information superiority—a key capability supporting the RDO concept. The CIE should be enabled by secure, high-speed fully networked information systems. The electronic collaborative planning tool suite can be used to virtually link the JTF, the components, and other organizations

³ SIAM is a software application called the Situation Influence Assessment Module that is owned by SAIC, Inc.

separated by geography, time and organization boundaries. The CROP is an effective means for rapidly disseminating important situational awareness information. In the future, there will be a lot of useful information available on the CIE. This means that information discovery tools must be improved to assist the user in searching the network for relevant information and to track actions so that sources of information can be retrieved later. As time goes by, it can become increasingly difficult to determine the most recent source of information for the subject area being researched—one may begin to suffer from information overload. An observed intended but also unintended consequence of the improved information environment was that the JTF staff could spend a lot of time on the collaborative information environment monitoring presentations and briefing refinement activities. The collaboration tools will be used extensively for building briefings, sharing information, chat rooms and coordination of planning activities.

Information Operations Observations

Information Operations (IO) is a means to create desired effects or outcomes that influence an adversary's behavior, will, perceptions and understanding. IO attacks the mind of the opponent as much as his systems. JP 3-13 (see reference 6) defines Information Operations (IO) as "Actions taken to affect adversary information and information systems, while defending one's own information and information systems." Draft revisions to DoDD 3600.1 (see reference 3) suggests changes to the definition of IO that includes influencing and defending "decision-making" and describing IO in terms of *core capabilities*, *related capabilities* and *supporting capabilities*. *Core IO capabilities* include operations security (OPSEC), PSYOPS, military deception, electronic warfare (EW), and computer network operations (CNO). *Supporting capabilities* include information assurance (IA), physical security, physical attack and counterintelligence. IA protects and defends information and information systems by ensuring their availability, integrity, identification and authentication, confidentiality, and non-repudiation. It also includes restoration of information systems by incorporating protection, detection, reconstitution, and reaction capabilities. *Related capabilities* include public affairs (PA), and civil military operations (CMO). PA communicates accurate, balanced, and credible information to critical leaders and the public. CMO establishes relations among military forces, international organizations, NGOs, the public, local businesses, and local and regional civil authorities to exchange information, build understanding, and gain information. All of these capabilities lie on a solid foundation of intelligence support.

Today's global information environment is a complex operating space for the IO warriors. It is no longer simply dealing with one's national media and the local media in the area of the conflict, now it is necessary to deal with the regional and international media who impact perceptions as well. The adversaries control their media and in many instances employ professional propagandists to conduct internal and global perception management. During crisis situations both the adversary and friendly forces generate disinformation and both use the media extensively to disseminate information to mold local, regional, national, and international opinions. Even the media has been accused of incorporating a version of disinformation by demonizing the adversary and predicting war is inevitable while the politicians are calling for diplomacy and only warn of military

retaliation (reference 5). The 24x7 international media cycle has placed additional demands on public diplomacy initiatives and need to effectively coordinate the government and military public information office activities. The “CNN Effect” (real-time unsubstantiated reporting from the field) continues to challenge the military and the chain of command reaction to such reports. Internet email and web sites provide another means for instantly communicating and informing, including disinformation.

Knowing and understanding the media consumption habits and social, religious, cultural, political and economic issues of the target audience have become extremely important and real world experience suggests we have not done that well. Target audiences can range from the unsophisticated to very sophisticated. The IO techniques used need to understand these differences in order to properly influence and win the hearts and minds of the local population, to gain regional and world support, and to shape the adversary’s decisions. We need to be able view things through the understanding and value system of those we are trying to influence, not through ours alone. Progress is being made but much remains to be done. IO products and methods are maturing with the globalization of information. The traditional posters, handbills, leaflet drops, loudspeakers, and radio and TV broadcasts still dominate the means of delivering the information campaign but cyberspace and cellular phones are becoming a more important part of the inventory of actions to take to manage perceptions and influence change. Leaflet drops and Commando Solo radio broadcasts were advertised as the dominate means for delivering IO messages in Afghanistan and Iraq and in MC02 when the JTF commander asked for more IO, it was leaflet drops and Commando Solo that got tasked to do the job.

IO needs to be a proactive, continuous process that starts long before the military operation begins and troops actually are deployed and combat operations initiated and continues after the conflict ceases. The principles of IO apply to all phases of the spectrum of operation—influence, deter, coerce, compel, defeat, transition and then influence. In practice, IO actions have tended to be more reactive and start later in the operation rather than in preparation for, then in support of the operation and continue after the cessation of hostilities and withdraw of forces. The process of transitioning IO concepts into a war fighting capability means the related policy, doctrine, and tactical applications are being modified, developed and refined and therefore, IO has different meanings to different people until the change process is completed. It is, however, more than Commando Solo broadcasts and leaflet drops that seem to be the preferred options in the real world and experiments and exercises. In fact, cyber warfare has emerged as one of the key elements of the new world of IO.

There are a number of other factors influencing not only the ability to operationalize IO but also the introduction of war fighting concepts such as Effects Based Operations that employ IO as an enabling capability (references 2, 3, 4, 12, 13, 14, and 15). Changing the attrition-based warfare culture to think effects and to use means other than lethal force has proven to be a challenge operationally. For example, in Kosovo the Commander of Multinational Brigade East continuously ask his planning staff if they had considered the 2nd and 3rd order effects of courses of action proposed and throughout the MC02 experiment, the JTF commander frequently reminded the planning staff to think about the effects they were trying to achieve and to think through the possible unintended consequences of their proposed courses of action. Although the availability of trained

and experienced information warriors is improving, the pipeline of trained IO professionals is still lacking for meeting the global operational needs. IO cells supporting Joint Task Force headquarters operations still tend to be ad hoc creations and frequently are not composed of a team of professionals that have trained together as a functioning IO cell before being deployed to support an operation, as would be the case for a maneuver unit. Elements such as the Land Information Warfare Activity (LIWA is now the 1st IO Command) field support teams (FSTs) were employed in the Balkans to help bridge the IO knowledge and capability gap.

Although IO tools are emerging, the vertical integration between echelons of command and horizontal integration between IO units still lack common tools to support integrated IO planning, execution, and assessment (reference 2). Collaboration and coordination among and between Combatant Commands, Services, and Agency activities remain problematic as well. New arrangements such as SPACECOMs Space and IO Element (SIOE) have been created to facilitate the planning, coordination and execution of IO campaigns but the final arrangements for integrating IO into operations are yet to be full understood and agreed. If IO is to be viewed as a primary war fighting capability then organizationally it needs to be represented at the JTF commander's table as other capabilities such as the maneuver forces commanders. Experience suggests that IO tends to be embedded within the Operations element or some other subordinate element of the JTF HQs command arrangements reducing its visibility to the JTF commander and its integration into operational plans and use as a key war fighting capability. The appropriate organization arrangements and location of IO functions within a Joint Task Force headquarters operation are still under consideration. MC02 tested some new concepts for integrating the activities of the SIOE, the JTF HQs IO Cell, and the Joint PSYOP Task Force (JPOTF) and as a result of this experience lot's has been learned but more work needs to be done to determine the appropriate operational command arrangement. The fact remains that for experiments, exercises and real world operations there are overlaps in IO activities that need to be de-conflicted. The latter is particularly true for highly classified and sensitive IO related actions where many of the JTF HQs Operations and IO planning staff are not likely cleared to know about them in advance of execution, and therefore, they cannot appropriately factor them into the overall JTF HQs planning, execution and assessment activities (reference 2, 12, and 14).

Visualization and assessment of the long-range impacts of IO actions are also somewhat problematic since shaping opinions and behavior are hard to visualize and the effects take time to happen. Experiments and exercises do not easily accommodate the uncertainty and long lead time of IO effects associated with the use of non-lethal means to achieve desired effects—diplomatic, social, information, and economic. Winning hearts and minds are achieved through trust relationships and trust is earned over time. The ability to influence changes in population perceptions and adversary behavior and the decision making processes of an adversary can take long periods of time to become effective. Using modeling and simulation to predict effects can reduce the real time to fit an experiment or exercise but if it is not carefully incorporated, the results can also add artificiality. Models and simulations that could accommodate and predict influences of non-lethal IO actions are lacking and this adds to the challenge of properly considering and assessing the impact of IO actions in the EBO planning process. Elaborate

PowerPoint briefings with creative icons, embedded pictures and images and detailed graphics tend to be the dominant mode for visualizing actions and effects.

As noted, assessment of effects are a particular problem for experiments and exercises where there is a limited time of play that introduces some artificiality into assessing the end impact of IO actions. Few tools and models and simulations exist to develop IO courses of action and to assess the effects of these actions (reference 2). As a result, IO Plans Cells use of tools to help examine and assess the PMESII effects and DIME actions over time are lacking. This is where the CAESAR II/EB tool could be of some assistance in developing and assessing IO-related courses of action. Additionally, it is difficult for IO Cells to effectively predict achievement of effects and in this regard, agreed measures of performance and effects are lacking as well. Lack of MOPs and MOEs is true for real world IO operations. Additionally, the Intelligence, Surveillance and Reconnaissance assets tend not to be IO effects oriented and therefore, there is a need to adapt these capabilities to facilitate IO targeting and collection of effects of IO actions.

There is also an artificiality introduced by war games, experiments, and exercise regarding the information campaign PSYOPS product development and testing (leaflets, scripts for Commando Solo broadcasts, and other material) and effects assessments since there generally is no “real world target audience” participants playing and many of the time lines for achieving effects exceeded the duration of the experiment and exercise. IO product testing and the equivalent of Battle Damage Assessment (BDA) for an IO campaign are challenges yet to be adequately addressed and solutions provided. The product pre-testing and approval process needs to include those who will be message recipients or understand the likely reaction of those who will receive the message—view through the eyes of the target audience or surrogate SMEs not the Blue forces perception of how the target audience might react. Information campaign effectiveness assessments are difficult to conduct as well since TTPs and the MOEs and MOPs are still being developed and tools to recognize and assess IO effects are lacking. ISR systems need to be tailored and tasked to collect IO effects. Assessments need to be more than number of leaflets drop per unit area or radio/TV broadcasts per area. Assessments need to make sure that the intent of the message developed in English was the message received in the target audience language and that they understood the intent of the message. This means that the translators that help develop the products need to be capable of reading, writing and comprehending and that the product developers need to understand the political, social, religious, symbolic, taboos, and cultural sensitivities of the messages and means by which they are delivered. Assessment also has a monitoring element to ensure the message is getting out and for quality control of the products and damage control in the event an unintended consequence needs to be rectified.

Computer Network Operations (Computer Network Attack, Defend, and Exploit) are difficult to incorporate in large, broad-based experiments and exercises. CNA staff can explore possible actions but there are limited possibilities to follow through on proposed plans. There are limited mechanisms to test the coordination and approval process for CNA activities and ability to simulate effects of CNA actions. CND and Information Assurance also tend not to be adequately addressed in terms of intrusion detection, protection and recovery in response to simulated computer network attacks or virus introductions into the supporting information network. The arguments used are that the primary focus of the experiments and exercises are to evaluate concepts and C4ISR

capabilities and the use of the collaborative and distributed planning environment and that the operational impact of losing these information systems during the experiment are not considered part of the objectives of the experiment. Operational impacts of network vulnerabilities certainly need to be examined in future experiments and exercises—operational network performance and recovery under stress such as high usage demands, computer network attacks, virus infections, and node and link failures need to be better understood, especially if there is limited (or no) manual backup to support the operational command and control and information sharing needs.

Operationally, the IO Cell can play an important role in support of OPSEC by monitoring, reviewing and assessing JTF generated material that will be released by the command for public consumption and by the commander and staff activities related to interviews with the media and meetings with key military, political and religious leaders. Open literature search of local and international (translated into English when necessary) media reports and web sites provide important insights into perceptions and misperceptions of the operation and whether the message intended was in fact the message received, reported and understood by the target audience. Use and misuse of communications and information systems is a key element of not only Information Assurance but OPSEC as well. For example, in the information age, details on homepages and discussed in emails to home can inadvertently inform others, including the adversary, of intentions, capabilities and vulnerabilities. OPSEC plays an important role in the coordination of fires, maneuver and IO because it is import to deny the enemy critical information about Blue force capabilities and intentions. Likewise, OPSEC has a deception piece as well that allows certain information to be made available to the enemy in support of deception operations. Consideration of unintended consequences of OPSEC short falls has and continues to be a challenge to appropriately incorporate into the effects-based planning and assessment activities.

Some Thought for the Future

The challenges of integrating IO into EBO span culture change, organization, training and education, doctrine, CONOPS, Tactics, Techniques, and Procedures (TTP), planning and analysis and M/S tools, and C4ISR capabilities to facilitate the planning, execution, and assessment of IO and EBO courses of action. The following are some general observations:

1. IO is more than leaflet drops and Commando Solo broadcasts, especially in the new world of global information and the 24x7 international media cycle. Cyber warfare has come of age. Information Operations require a comprehensive and integrated strategy from the inception of the operation. IO needs to be employed before an operation begins, continue throughout the conflict phase and then into the post conflict phases. The commander and staff need a clear understanding of the end state and it is essential that they know and understand the target audience and its sensitivities, habits and behavior. IO needs to use multiple means to convey information. One must also be careful not to raise unattainable expectations with an information campaign. Additionally, to be effective, actions need to support words. Finally, IO requires the military commander's personal

involvement and leadership and it must be a key element of his plans and operations staff. The use of a Joint IO Task Force may be a way to elevate its status within the JTF organization.

2. Better tools, including modeling and simulation capabilities, need to be provided to facilitate IO courses of action planning and assessments and to simulate effects of IO actions in support of experiments and exercises. Such tools need to be able to assess the success or failure and the intended and unintended consequences of IO actions. ISR tools and capabilities are also needed to recognize the effects of IO actions and to facilitate tasking ISR collection of the effects of IO actions including more effective use of HUMINT assets. Improved ISR systems tailored to targeting and collecting the effects of EBO and IO actions are needed as well.
3. Measures of effectiveness and performance are needed to support IO planning and assessments and indicators need to be developed to guide ISR tasking activities and development of new collection capabilities.
4. Joint and Service professional military education and training programs are needed to address EBO and IO course of action planning and assessment. There is a need to develop a training program to produce IO warriors. In addition, the military system needs to treat IO as a military career field equivalent to other war fighting fields so that IO cells can be populated with experienced information operations warriors that have been trained in advance as an operationally ready, effective fighting element.
5. Recent war games and experiments has show that the CIE is a powerful capability that significantly improves information sharing and collaboration but like the real world operational systems, better information discovery tools are needed to improve the ability to find the right information at the right time. Procedures also need to be developed for the use of the IWS terminals in support of decision-making. The ONA needs tools to improve the ability to access and search the database, conduct analyses, and package information including visualization. Linkage of the ONA to other CIE web sites would be useful as well as improved interfaces to facilitate operational updating of information and analysis contained in the database. JIACG subject matter expert skill mix needs to be tailored to meet the operational needs of the JTF commander and his staff. In a real world operation, allies and world opinion, including the US internal political and public opinion, will also influence JTF EBO planning and assessments so this type of information needs to be provided to JTF staff by the JIACG and/or contained in the ONA database and other homepages.
6. Develop a concept of operations for future experiment and exercise support arrangements that allow outside teams, such as the GMU team, to actively participation from the initial planning stages through AAR phases. Arrangements also need to be made to accommodate the integration of the team into the appropriate element of the operational planning staff with pre-approved authority

to access the required decision makers, SMEs, planners, analysts, tools and databases, and operational activities necessary to gain the insights and support required to construct appropriate COA models and conduct effects assessments to meet the needs of the experiment or exercise. In a CIE-like environment, team member should be given the equivalent of an IWS terminal to allow them to participate in all appropriate activities and access databases and web sites.

References

1. AFOSR/NM, Broad Agency Announcement 2002-1, Decision Support for Effects Based Operations in Support of JFCOM J9 Millennium Challenge 2002.
2. Air Force Information Warfare Center and Deputy Assistant Secretary of Defense Security and IO, "Phoenix Challenge 2003," 11-14 March 2003, Tysons Corner, VA
3. Deckro, Dick and Hathaway, Melissa (2002), "Information Operations Workshop Summary," MORS workshop at BAH, McLean, VA.
4. Kernan, Gen William F. and Cash, MG Dean (2002), Commander US JFCOM MC02 Lessons Learned Press Briefing³, Pentagon Briefing room, 18 July 2002 and 17 September 2002.
5. Knightley, Phillip (2001), "The Disinformation Campaign," The Guardian, UK.
6. Joint Chiefs of Staff (1998), "JP 3-13: Joint Doctrine for Information Operations."
7. Joint Forces Command (2002), "Pamphlet for Future Joint Operations," Joint War Fighting Center Pam 1, Suffolk, VA.
8. Joint Forces Command (2002), "Millennium Challenge 2002 Internet Home Page," Suffolk, VA.
9. Joint Forces Command (2002), "A Concept for Rapid Decisive Operations," RDO White Paper Version 2.0, Suffolk, VA.
10. Wagenhals, L. W. and Levis, A. H. (2002), "Effects-based Course of Action Analysis in Support of War Games," MORS workshop at BAH, McLean, VA.
11. Wagenhals, L. W. (2002), "Support to JFCOM J9 for MC02: Quick Look Report," Suffolk, VA.

12. Wentz, L. K. (1998), "Lessons from Bosnia: The IFOR Experience," CCRP/NDU publication, Washington, D.C.
13. Wentz, L. K. (2000), "Information Operations: The IFOR Experience," CCRP white paper, Washington, D.C.
14. Wentz, L. K. (2002), "Lessons from Kosovo: The KFOR Experience," CCRP publication, Washington, D.C.
15. Ulchida, T. T. (2002), "Analysis of Effects-Based Operations—The Road Ahead to Doing Business Differently," MORS workshop at BAH, McLean, VA.



Effects-Based Information Operations: Some Observations



Larry Wentz
8th International
Command and Control
Research and Technology
Symposium
17 June 2003
National Defense University

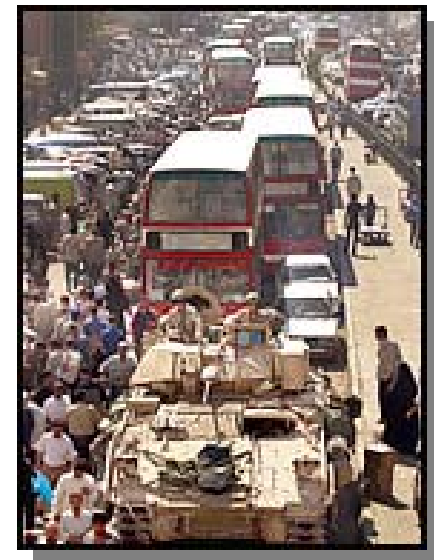

GMU

George Mason University

Information Operations is More Than Leaflet Drops and Commando Solo



**Commando Solo
(Radio/TV Broadcasts)**



	English Version	Arabic Version
Image		
Image		
Image		
Image		

Leaflet Drops

U.S. Information Operations

“Actions taken to affect adversary information and information systems, while defending one’s own information and information systems...”

- **Requires Close, Continuous Integration of Capabilities and Activities**
 - **Offensive and Defensive**
 - **Vertical and Horizontal**
 - **Compartmented and Collateral/Unclassified**
- **IO in Process of Being Operationalized**
 - **Primary War Fighting Capability**
 - **Military Core Competency**

Information Operations (IO) Capabilities



- **Core Capabilities**
 - Operations Security
 - ← – Psychological Operations
 - Military Deception
 - Electronic Warfare
 - Computer Network Operations
- **Related Capabilities**
 - ← – Physical Attack
 - Information Assurance
 - Physical Security
 - Counterintelligence
- **Supporting Capabilities**
 - Public Affairs
 - ← – Civil Military Operations

Built on Solid Foundation of Intelligence

Evolving Information Operations Focus



- **Move Away from “Integrating Strategy”**
- **Integrate as an Element of Overall Operation (Synergy)**
- **Focus on Development of Vulnerabilities**
- **Emerging Doctrine, TTPs, Capabilities, Tools, Training, & Education**
- **“Target the Appropriate *Node* (Cultural or Infrastructure) with the Appropriate Capability to Achieve the Appropriate Effect”**
 - **Manage Expectations**
 - **Understand 2nd and 3rd Order Effects**
- **Influence Operations Becoming Key**
 - **Shape the Environment**
 - **Integrate PSYOP, Deception, CMO, PAO**

Information Operations: Influence Operations

Actions Need to Support Words

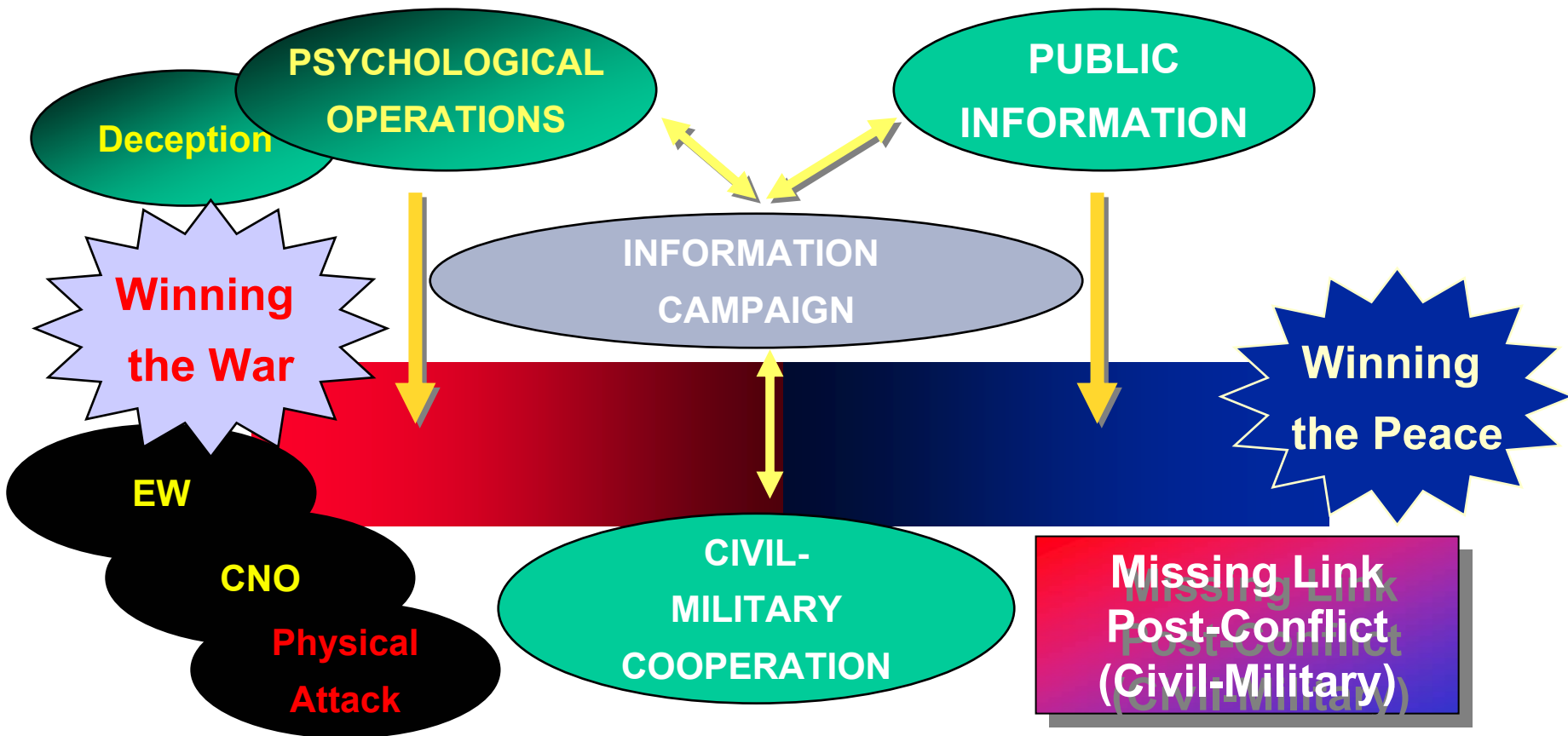

Information Environment



- **Adversary Information and C2I Systems**
 - Military and Civil
- **Propaganda and Deception Likely a Key Factor**
 - Warring Parties Control Media
 - Competing With Professionals
- **International Media**
 - CNN Factor (Unsubstantiated/Incomplete Reporting)
 - Embedded and Freelance (Everywhere)
 - 24X7 News Cycle (Including Talking Heads)
- **Internet and Telecommunications**
 - Email and Web Sites
 - Computer Network Attack and Exploitation
 - Cellular and Satellite Phone
- **Local Population**
 - From Unsophisticated to Very Sophisticated
 - Information Always Circulating
 - Not a Single, Homogeneous Entity
- **Field Incidents (First Reports Incomplete)**
- **Civil and Military Information Campaigns**
 - Leverage Truth
 - Competition and De-confliction

The Challenge: “What Effects do you Want?”

- Linking Effects to Nodes to Actions to Resources
- Apply full range of national power to defeat an adaptive adversary by attacking the coherence of his centers of gravity

Elements of National Power

- Diplomatic
- Information
- Military
- Economic

Adversary Centers of Gravity

- Political
- Military
- Economic
- Social
- Infrastructure
- Information

**Information is an Integral Part of the
National Elements of Power...**

Thinking Effects



Willingness to Arrest War Criminals in Bosnia

- **Establish Cause Effect Linkages**
- **Tangible and Intangible Domains**
 - **1st Order Effects**
 - **Observable and Quantifiable**
 - **Physical Destruction of C2 Nodes**
 - **2nd Order Effects**
 - **Aggregate of Actions**
 - **Ability to Exchange Information and Conduct C2 Degraded**
 - **3rd Order Effects**
 - **Subjective**
 - **Attitudes**
 - **Perceptions**
- **Unintended Consequences**
 - **Windows of Vulnerability**

EFFECTS BASED INFORMATION OPERATIONS

- **Planning**
 - Identify desired effects
 - Identify actionable events and relate them to the effects (establish a cause-effect relationship)
 - Develop strategies that maximize the probability of achieving the desired effects
 - Determine a set of indicators of progress and when those indications are likely to occur so progress can be monitored
- **Execution**
 - Be able to measure the degree to which the desired effects are being achieved as the plans are executed (Assessment)
 - Be able to identify undesired effects and unintended consequences
- **Creating and evaluating Courses of Action requires a **suite of tools** that support an **Effects Based process****

Know Your Target Audience



AM RADIO

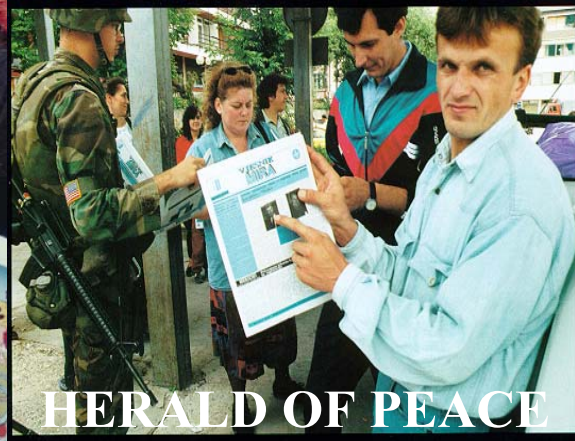

HERALD OF PEACE



POSTERS

Bosnia Target Audience
FM Radio
Television

- Media consumption habits
 - Print material
 - Radio and TV
 - Internet
- Knowledge of customs and issues
 - Religious
 - Cultural
 - Political
 - Social
 - Economic
- Understand taboos, mindset, beliefs and behavior
- Local, Regional, US, Western, and International

Range of Products and Methods

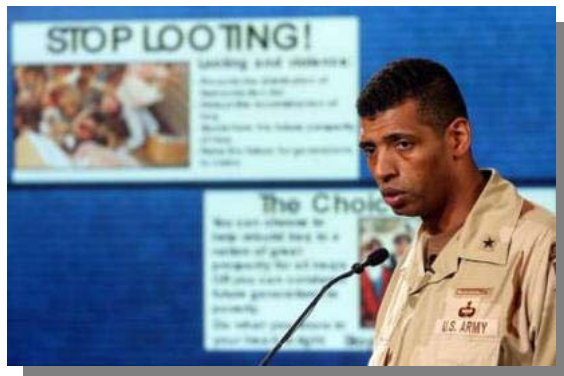

- Leaflet Drops
- Commando Solo Airborne and TARBS Ship Broadcasts
- Media Conferences, Interviews, Staged Events
- Radio Messages and TV/video Products
- Tactical PSYOP Teams (Face-to-face)
- Fund Local Radio and TV Stations
- Internet Web Sites and Emails
- Telecommunications Including Cellular
- Posters, Handbills, Pamphlets
- Loudspeakers
- Magazines, Newspapers (Including Inserts)
- Medical and Dental Civil Action Programs
- Talking Point Papers
- Miscellaneous
 - Soccer Balls, Baseball Hats, T-shirts
 - Coloring Books, Crayons, Pens, Pencils, Note Pads

Delivery Means



STOP THE VIOLENCE



Does it matter if I am Albanian or Serbian?

ONLY YOU CAN STOP THE VIOLENCE!!!

INTERNATIONAL BROTHERS EAST (INTE)
—KFOR—

ONLY YOU CAN STOP THE VIOLENCE!!!

Product Testing and Assessments

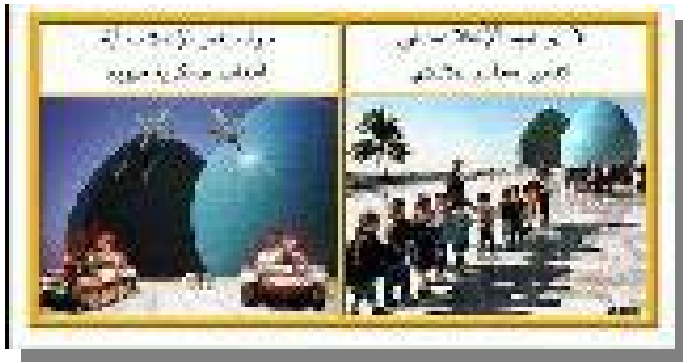

- **Pre-testing (PSYOP)**
 - Local hires
 - Interpreters/Translators
 - Random street sampling
 - Media representatives
 - Quick studies
 - Subject Matter Experts
- **Assessments**
 - BDA and Friendly Unit Reporting
 - Numbers and Coverage of Products/Actions
 - Gallop-like polls in peace operations
 - Open source monitoring and assessments
 - Print, Radio and TV, Internet
 - Tape radio and TV shows and review
 - PIO, PSYOP, CIMIC situation reports
- **Cause Versus Effect Linkage**
 - Tangible (Physical) and Intangible (Perception, Attitudes) Effects
 - 1st, 2nd and 3rd Order Effects

Joint Information Operations Experiences

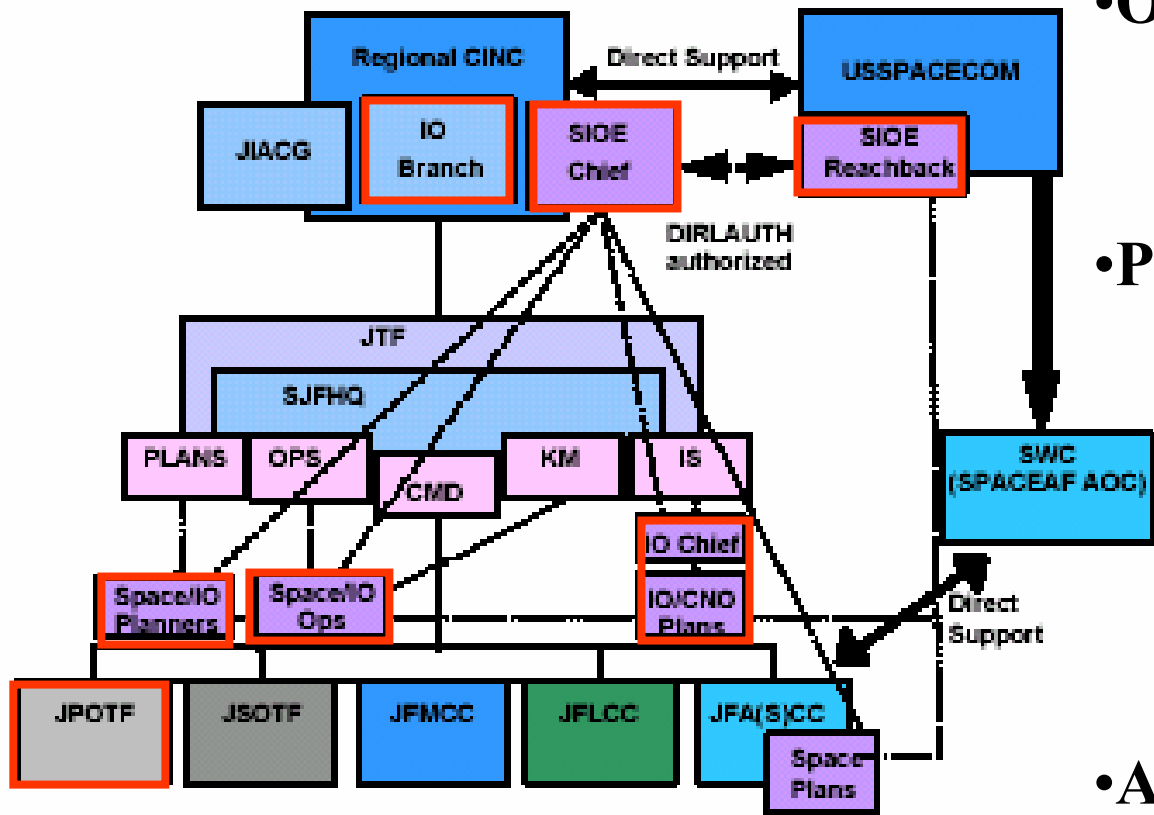

- **Organization and C2**
 - Commander Interest
 - JTF Arrangements
 - IO Cell/SIOE/JPOTF
- **Plans and Execution**
 - Ops (Integration of IO)
 - Approval/Authority
 - M/S Tools and ISR
 - MOEs and MOPs
 - Coordination/Tasking
 - H/V and RCCs
 - Special Access (STO)
- **Ad Hoc IO Cell**
 - Staff Skills/Experience
- **Linguists/SMEs**
- **Training/Education**

**More Than a War Fighting Capability
Also Winning the Peace**

Operation Iraqi Freedom (IO Examples)

- **PSYOP Campaign (Desert/Surrender, Do Not Use WMD, Do No Sabotage Oilfields, Against Gov't Regime Not People or Nation)**
 - **Leaflet Drops**
 - **Distributed 36 Million Leaflets**
 - **Commando Solo and Other Radio Broadcasts**
 - **Distributed Solar-Powered and Hand-Crank Short-wave Radios**
 - **Instructions to Tune to Arabic-language Broadcasts**
 - **Special Forces**
 - **Iraqi Opposition Leaders Taken into Villages to Urge Support of US**
 - **CNO (CNA)**
 - **Emails to Senior Iraqi Military and Civilian Leaders**
 - **Wanted Posters with Pictures Posted in Towns**
 - **Baath Party Members and Fedayeen Militia Leaders**

Operation Iraqi Freedom (IO Examples)

- **EW/Deception**
 - **Jam and Spoof Iraqi C2 and Air Defense Networks**
 - **Trucks with Loudspeakers and Drones**
 - **Broadcast Recordings of Truck and Tank Movements**
- **Physical Attacks**
 - **Iraqi Radio/TV Stations and Telecommunications Facilities**

Some Things Worked

- **Iraqi Military Force Surrenders Followed Leaflet Instructions**
- **Iraqi Oilfield Workers Decided Not To Sabotage Oilfields**
- **Spoofing Demoralized Some Iraqi Military Elements**
- **WMDs Were Not Used (But Also Not Found)**
- **Civilian Population Attitude Toward Coalition Forces Positive**

Some Things Did Not Work

- **Failed to Produce Significant Defections of Senior Iraqi Military and Civilian Leadership—Did Not Meet Expectations**

The Future: Some IO Challenges

Winning Both the War and the Peace



Victor R. Caivano / AP



AFP



Gleb Garanich / Reuters

- **Senior Leadership**
 - “Will” to Use
- **The Message and Techniques**
 - Know the Target Audience
 - Pre-Product Testing
- **Planning and Assessment**
 - M/S Tools
 - Agreed MOEs and MOPs
 - Area Experts and Linguists
- **Execution**
 - Organization (SIOE, IO Cell, PSYOP)
 - Collaboration and Synchronization
 - Cumbersome Approval Process
 - IO-Focused ISR Capabilities
- **Training and Education**

**Making Progress but Much
Remains to be Done**