

Heat Generation during Overcharge in Sealed Cells

Henry A. Catherino
U.S. Army Research Development and Engineering Command
AMSRD-TAR-R/MS 121
Warren, MI 49397-5000
catherih@tacom.army.mil

Abstract

A popular explanation for the heat generated when a sealed cell is overcharged is that the oxygen recombination taking place at the negative electrode is an exothermic process. Although it is a fact that this recombination reaction is exothermic, the first law of thermodynamics mandates that the net enthalpy of the closed cycle oxygen recombination process is exactly zero (also known as Hess's Law). Since the closed oxygen cycle cannot produce any enthalpic heat, the heat generated must be entirely of Joule origin. The alternative mechanism discussed in this paper is that the gas evolution process displaces the electrolyte in the intercell gap and by doing that, causes a substantial increase in the internal resistance of the cell. The consequence of this resistance increase in the presence of current passing through the cell is a significant contributor to the observed heat generation. This paper presents data and discussions that support this interpretation. This mechanistic interpretation has some notable implications. That is, the heat generation process is largely chemistry independent (i.e., it is common to all sealed cell designs), is the consequence of the ability of the separator to manage the electrolyte distribution within the cell and can thermally accelerate thermodynamically spontaneous processes that have slow kinetics under normal ambient conditions.

Introduction

On occasion, an inconsistency is encountered in our accustomed thought patterns. In even rarer occasions, these inconsistencies drive the need for restructuring of the thought patterns that lead to a clearer understanding of our accumulated experience. This is the essence of the seminal work of Thomas Kuhn entitled, "The Structure of Scientific Revolutions." [1]

Although the discussion here does not hope to compare with the magnitude and significance of the paradigms discussed by Kuhn, the development of this paper suggests that a rethinking is necessary. Indeed, we may require a mini-paradigm shift in how we understand the heat generation taking place during overcharge in sealed cells.

Report Documentation Page

Form Approved
OMB No. 0704-0188

Public reporting burden for the collection of information is estimated to average 1 hour per response, including the time for reviewing instructions, searching existing data sources, gathering and maintaining the data needed, and completing and reviewing the collection of information. Send comments regarding this burden estimate or any other aspect of this collection of information, including suggestions for reducing this burden, to Washington Headquarters Services, Directorate for Information Operations and Reports, 1215 Jefferson Davis Highway, Suite 1204, Arlington VA 22202-4302. Respondents should be aware that notwithstanding any other provision of law, no person shall be subject to a penalty for failing to comply with a collection of information if it does not display a currently valid OMB control number.

1. REPORT DATE 09 AUG 2006		2. REPORT TYPE N/A		3. DATES COVERED -	
4. TITLE AND SUBTITLE Heat Generation during Overcharge in Sealed Cells				5a. CONTRACT NUMBER	
				5b. GRANT NUMBER	
				5c. PROGRAM ELEMENT NUMBER	
6. AUTHOR(S) Henry A Catherino				5d. PROJECT NUMBER	
				5e. TASK NUMBER	
				5f. WORK UNIT NUMBER	
7. PERFORMING ORGANIZATION NAME(S) AND ADDRESS(ES) US ARMY TACOM 6501 E 11 Mile Road Warren, MI 48397-5000				8. PERFORMING ORGANIZATION REPORT NUMBER 16088	
9. SPONSORING/MONITORING AGENCY NAME(S) AND ADDRESS(ES)				10. SPONSOR/MONITOR'S ACRONYM(S) TACOM TARDEC	
				11. SPONSOR/MONITOR'S REPORT NUMBER(S) 16088	
12. DISTRIBUTION/AVAILABILITY STATEMENT Approved for public release, distribution unlimited					
13. SUPPLEMENTARY NOTES					
14. ABSTRACT					
15. SUBJECT TERMS					
16. SECURITY CLASSIFICATION OF:			17. LIMITATION OF ABSTRACT SAR	18. NUMBER OF PAGES 15	19a. NAME OF RESPONSIBLE PERSON
a. REPORT unclassified	b. ABSTRACT unclassified	c. THIS PAGE unclassified			

The object of this presentation is to focus on the well established and widely accepted view that the closed cycle oxygen recombination cycle is the cause of the heat generation in sealed cells during overcharge.[2, 3, 4] A VRLA battery in overcharge can become sufficiently hot so as to result in the boiling of the electrolyte. The internal resistance of the cell measured under static conditions is quite small. The observed heating is much too large to be accounted for by Joule heating calculated from the measured steady state battery resistance. That is, the measured internal resistance of cells of this kind is much too small to explain the heat generated solely from I^2R (Joule) losses. However, the recombination of oxygen on the negative electrode is a very exothermic reaction. The phenomenon of the oxidation of finely divided metals in air is often pyrophoric. This awareness gives a high credibility to the view that the closed oxygen cycle is necessarily the cause of the heat generation when these cells are overcharged. Presently, this is the prevailing interpretation that is ubiquitously offered to explain the heating effect.

However comfortable this view might be, it leads to a significant inconsistency from a first principles perspective. The discussion which follows will address this inconsistency, propose an alternative mechanism and discuss three studies that support the alternative mechanism. For the sake of clarity, the heat generation mechanism brought about by the closed oxygen cycle shall be termed the traditional paradigm.

Discussion

The closed oxygen cycle paradigm explaining heat generation in sealed cells has been around since 1947. The implementation of the closed oxygen cycle is associated with the work of Georg Neumann.[5] The following reaction could be considered the fundamental overall process associated with the recombination of oxygen in sealed cells.

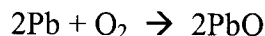

$$\Delta H \text{ (standard heat of formation)} = - 390.4 \text{ kJ/mol Pb}$$

Note that lead is being used as the referenced reactant. The reaction shown can be found in critical tables of heats of reactions and it is exothermic.

There is a serious problem with this interpretation. The dilemma appears immediately when one tries to write the reaction as a closed chemical cycle. This cycle is shown in Figure 1.

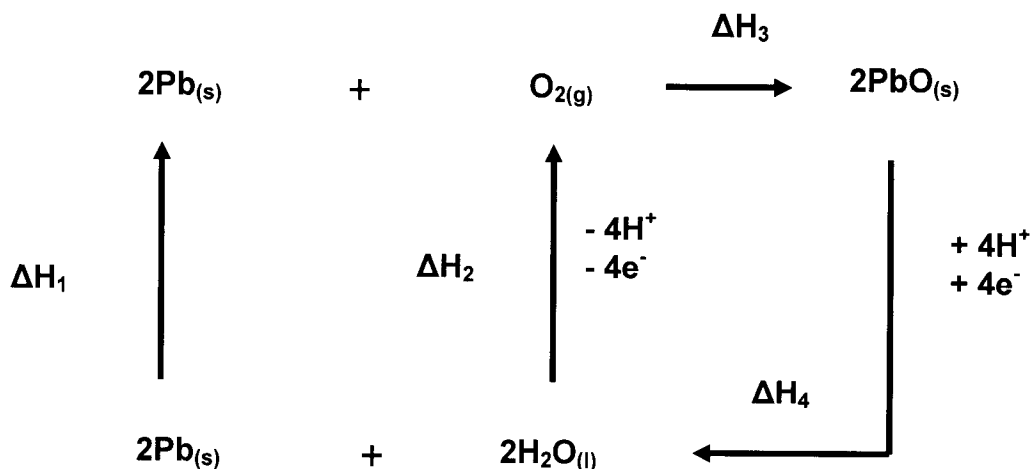

Figure 1. Born-Haber Cycle illustrating the closed oxygen cycle.

It is critical to note also that the discussion that follows applies to all conceivable cyclical process representations. One might disagree with the formulation of the cycle shown in Figure 1 but however one might choose to express the steps in the cycle, the same arguments apply. To proceed, the evident problem is that the cycle is composed of a collection of steps and each has its own associated enthalpy. The net heat associated with the closed cycle is actually the sum of the heats associated with each of the steps shown. It appears that focusing only on the oxidation of the metal ignores the other chemical or electrochemical processes that are taking place concurrently.

To add to the problem is that the first law of thermodynamics, i.e., the energy conservation law, which mandates that the sum of the enthalpies is zero for all closed chemical cycles. This is a corollary of Hess's Law of Heat Summation.[6] Hess's law states that "the heat evolved or absorbed in a chemical process is the same whether the process takes place in one or in several steps." To claim that the net heat produced in a close cycle is other than zero would suggest that the direction by which one moves around the cycle would result in either the creation or destruction of energy. The discussion that follows shall adhere to the assumption that that the energy conservation law is always true.

Having said that, we are left on the horns of a dilemma because it is known that cells placed on overcharge generate heat but we have just declared that the traditional mechanism for justifying the heat generation process constitutes a violation of the energy conservation law.

Although the essential point has been made above, as a practical matter the discussion should be carried further. The next step is to propose an alternative mechanism (a new paradigm) for explaining the heat generation effect. The new paradigm is constrained in that it can contain no heat generated by closed cycle chemical processes. That is, the heat generation must be the consequence of Joule heating and that heating must be of resistive origin. Note that one can associate the resistance build-up with some sort of resistive

film formation associated with known effects such as PbO or PbSO₄ formation. For the discussion that follows, the growth of resistance shall be postulated as the consequence of electrolyte being displaced out of the inter-electrode gap by gas generation. The gas would be the oxygen that is generated by the overcharge reaction taking place as part of the closed oxygen cycle. This paradigm specifically requires that no closed cycle chemical process can generate heat.

Since the argument raised thus far is of a theoretical nature, it would be nice to generate some experimental justification supporting the new paradigm. In summary, there are two paradigms under consideration:

Traditional Paradigm: the heat generation on overcharge is largely the consequence of the closed oxygen cycle caused by oxygen recombination at the negative electrode.[2, 3, 4]

New Paradigm: the heat generation on overcharge is controlled by the build-up in inter-cell resistance caused by electrolyte displacement by the gas evolution process and the current passing through that resistance (Joule Heating). Although the heating associated with the battery resistance is small, the remainder is the power dissipated as heat by the passage of a current through the voltage gradient of the battery. Also, the dissipation can be associated with an equivalent resistance so as to make this a Joule heating component. This latter component shall be discussed further below.

Three studies follow that are consistent with the new paradigm but not the traditional paradigm. The first study involves observations made of the thermal runaway effect. While performing that study, a peculiarity appeared that was totally inconsistent with the traditional paradigm. At that point, the new paradigm was developed. It is well established that the characteristics of any good scientific theory is that the theory can be verified and that the theory could be predictive. Then, the second study describes measurements made to determine the resistance changes in a cell when it goes into overcharge using Electrochemical Impedance Spectroscopic (EIS) techniques. The third study predicts that a condition can exist where the cell goes into electrical oscillation. This could be an example of electrochemical chaos. Since electrochemical cells are the classic example of pure direct current, a case that reveals a self generated alternating current component is quite novel.

Case 1 – Thermal Runaway

The impetus for generating the new paradigm came as a consequence of a peculiarity observed while performing a study on the thermal runaway of VRLA batteries. The details of this study have been presented elsewhere.[7] In short, the battery was precondition to induce the thermal runaway and then the battery was charged in the usual manner. Figure 2 shows the relevant data.

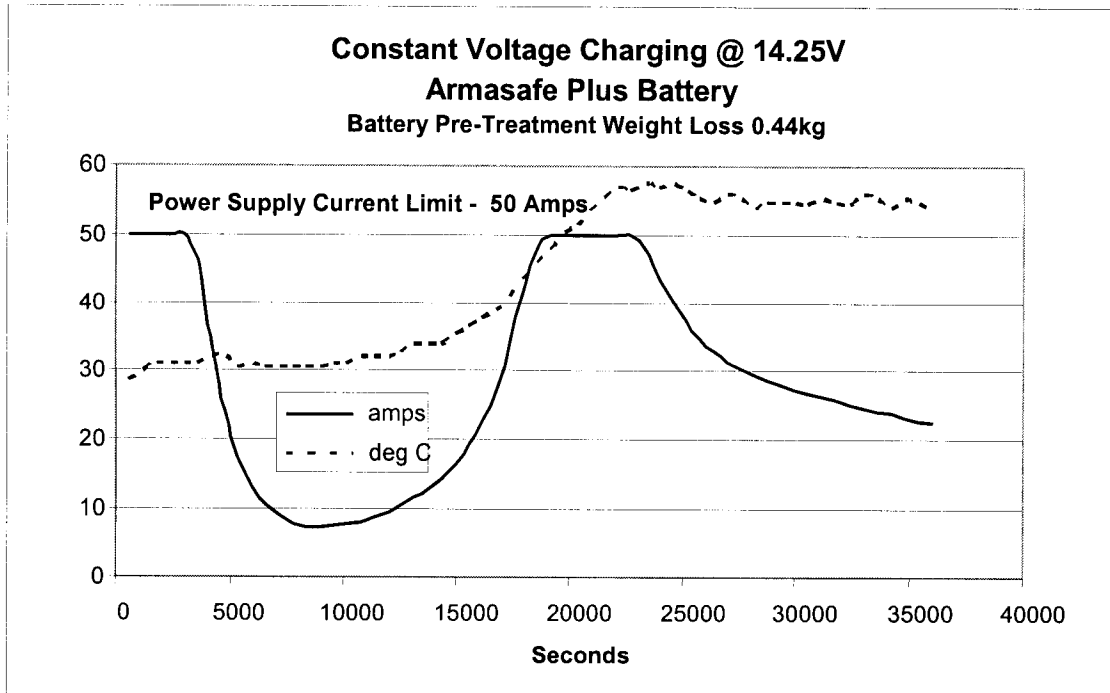

Figure 2. Thermal runaway in a VRLA battery being charged at constant voltage. A typical AGM of this size has an approximate water content per cell of 684 cc at 97% saturation.

Early in the constant voltage charging, the battery showed the exponential fall off of current until the thermal runaway took place. Just as the charging process was being completed, the current rose with a corresponding increase in the temperature. It must be noted that the temperature is that measured at the negative terminal. The internal temperature of the battery is actually greater than that value. The critical observation comes at the point where the current begins to fall off. What is observed here is that the temperature appears to remain approximately constant whereas the current passing through the battery falls off.

This behavior is totally inconsistent with the traditional paradigm defined above. The current passing through the battery is proportional to the oxygen generated at the positive terminal. In a sealed battery, the oxygen recombines at the negative. The decreasing current requires that the rate of recombination is decreasing. But the fact that the temperature is virtually constant indicates that the rate of heat generation is constant. That is, the rates of heat generation and removal are in a steady state. In addition, they are not changing. This creates a problem of interpretation that is extremely difficult while adhering to the old closed oxygen cycle paradigm.

The new paradigm where the heating is the consequence of electrolyte displacement within the inter-electrode gap provides a simple interpretation for this temperature-current response.

Assuming that only Joule heating is involved, the existence of a constant temperature requires that the rate of Joule heating is also constant. To further explain this, the constant temperature indicates that a steady state exists between the rates of heat production and removal. Since the rate of heat removal is determined by environmental and geometric considerations that have not changed, the rate of Joule heating is constant. Then,

$$I^2 R = k_1 \text{ (steady state condition)}$$

The constant is given by k_1 . R and I are the current and resistance. By definition, the resistance is defined as:

$$R = \rho l/A = k_2 / A \text{ (at constant T)}$$

Where ρ is the resistivity, l is the length of the current path and A is the cross-sectional area. Since the resistivity and the path length are fixed quantities, they have been lumped together and shown as k_2 . Substituting this back into the previous equation,

$$I^2 k_2 / A = k_1$$

Collecting the constants and assigning them the quantity k_3 , then

$$I^2 = k_3 A$$

and rearranging:

$$I = k_4 \sqrt{A}$$

This very simple analysis shows that if the current changes so as to be proportional to the square root of the cross-sectional area of the conductive electrolyte in the inter-electrode gap, the Joule heating must remain constant. The point here is that a current through a resistance can fall and at the same time the heat generation can remain constant. This experimental observation is consistent with the new paradigm but inconsistent with the traditional paradigm.

The next step is to attempt a verification of the physical model. Since the new paradigm requires that the resistance must be increasing as gassing is taking place, then it would be reasonable to expect that this resistance increase could be measured. This prompted the next study using EIS instrumentation.

Case 2 - EIS measurements during overcharge

The object of this study was to measure the impedance and phase angle as a function of frequency as a VRLA battery goes into overcharge. The experimental approach was to fully charge the battery and then bleed off some of the charge. The battery was then put back on charge and repetitive EIS sweeps were taken as the battery went into overcharge.

The charger was limited to 3 amperes and the voltage limit was set at 15.5 volts. The data was resolved to fit the equivalent circuit shown in Figure 3.

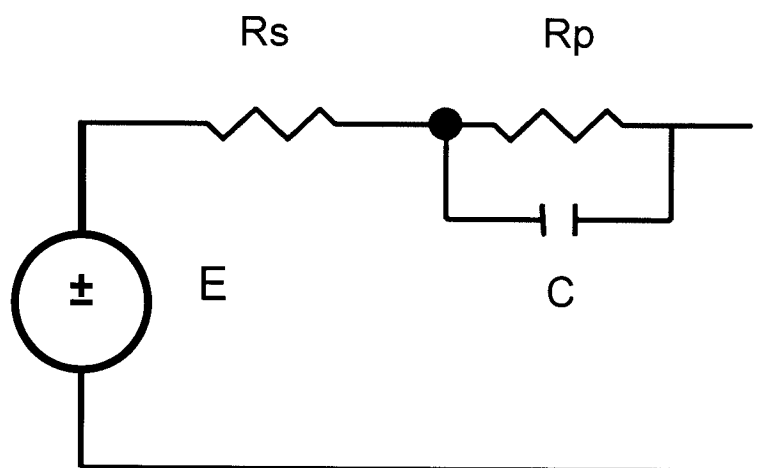

Figure 3. Equivalent circuit diagram that was fit to the data obtained by the EIS technique

The specific values obtained during each of the scans are given in Table 1. The scans were successively taken. The scan identified as run 1 was taken with no applied charge current as a reference point. The subsequent runs had the charger attached.

Table 1. Resolved values of R_s , C and R_p fit the equivalent circuit shown in Figure 3.

run	R_s	C	R_p
1	0.00287	10.48	0.00363
2	0.00286	7.38	0.0061
3	0.00281	5.709	0.01577
4	0.00285	5.225	0.03119
5	0.00292	4.725	0.12134
6	0.00287	4.504	0.12702
7	0.00286	4.353	0.10791
8	0.00283	4.313	0.2202
9	0.0029	4.313	0.6323
10	0.00288	4.33	0.77724
11	0.00286	4.323	0.79293
12	0.00289	4.282	0.74458
13	0.00285	4.273	0.8281
14	0.00286	4.261	0.82805
15	0.00293	4.242	0.82254

The values obtained are illuminating. The values of R_s basically remained constant. R_s represents the resistance associated with the kinetics of electron transfer. R_p represents the resistance associated with the ionic charge transfer through the solution. Finally, C represents the interfacial capacitance associated with the electrochemical cell.[8] The values of R_s hardly changes as the battery goes into overcharge. Alternatively, R_p shows a huge change in excess of two orders of magnitude. This large change in resistance is what was anticipated from the new paradigm and found.

There is another interesting feature about this data and it becomes evident when the data is plotted as shown in figure 4.

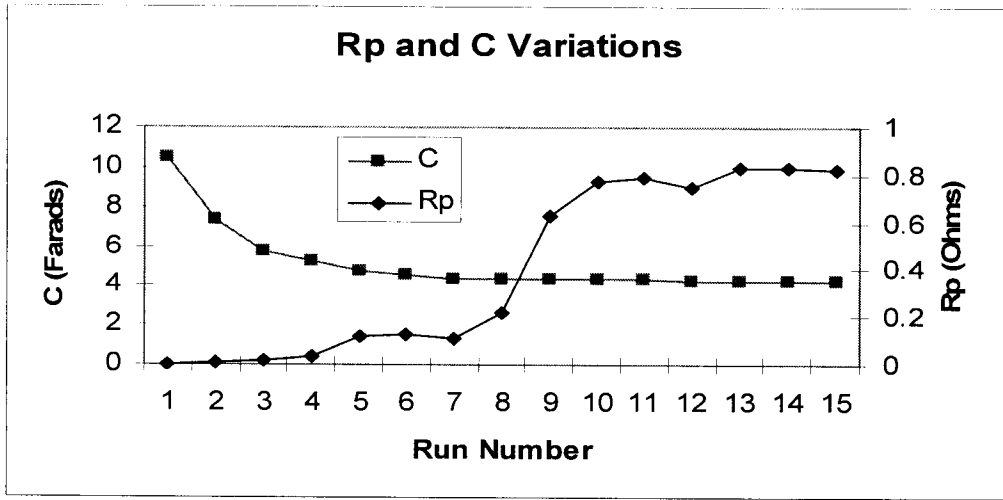

Figure 4. Comparison of the capacitance the resistance changes in the order of their measurement.

Figure 4 shows the capacitance decreases first. As the capacitance decrease stabilizes, the resistance makes its move to higher values. What is interesting about this data is that it is perfectly consistent with the new paradigm. That is, the gas generation model that displaces the electrolyte can explain this behavior.

To show that this behavior is consistent with the new paradigm, it is necessary to review some fundamental physical concepts. Capacitance is defined as:

$$C = \epsilon_0 A^*/d$$

where C is the capacitance, ϵ_0 is the dielectric constant, d is the separation of the plates of the capacitor and A^* is the plate area. In the case of resistance:

$$R = \rho l/A$$

where R is the resistance, ρ is the resistivity, l is the length of the resistive path and A is the cross-sectional area of the resistor.

Two key observations need to be made here. The first is that A^* and A are not the same. A^* represents the interfacial surface area where charge can be stored by some sort of charge separation. A , on the other hand is the cross-sectional area of the resistor. It represents the projected area of the surface as if it were planar. The inner surfaces of a porous electrode that do not face the counter electrode do not participate in determining the area term. Clearly,

$$A^* \neq A$$

In fact,

$$A^* \gg A$$

The second observation is the dielectric constant for a conductive ionic aqueous solution is about 30 and that of a gas such as oxygen is approximately 1.00. The resistivity of an aqueous ionic solution is very low compared to a gas which is virtually infinite.

With these considerations in mind, we can visualize a hypothetical pore in a flat surface as that shown in Figure 5. Certain liberties were intentionally taken in illustrating the pore in this way for the sake of conceptual convenience. However, the analysis would apply to all pore geometries. At this point, the rationalization that is consistent with the EIS data becomes evident. Taking the new paradigm as being operative, gas generation begins over the entire surface. The gas bubbles on the front surface have no barrier and can move away from the surface. The gas bubbles generated within the porous matrix are basically trapped.

The argument follows directly. As a gas bubble fills the pore, the area that affects capacitance is covered by a medium having a lower dielectric constant. However, the area that controls resistance is very small (as shown by the dashed lines). The resistance change caused by the gas bubble within the pore is a small effect relative to the capacitive effect.

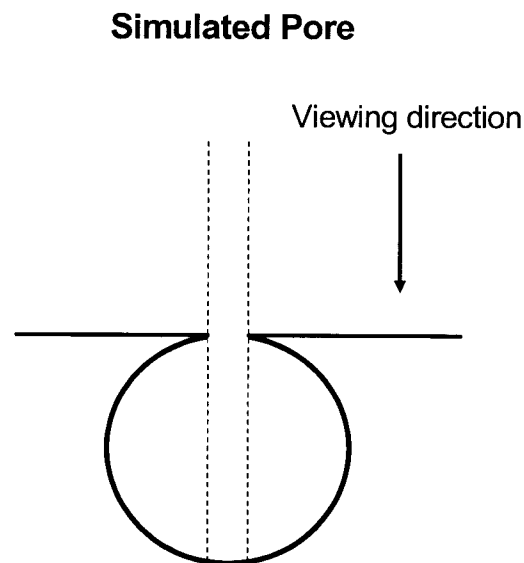

Figure 5. Idealized comparison of actual vs. projected surface of a pore.

After the gas displaces the electrolyte in the pores, the gassing then begins to displace the electrolyte within the inter-cell gap. With this visualization in mind, the data in Figure 4 becomes interpretable. That is, as gas generation begins, the pores fill with gas causing a small change in resistance and a large change in capacitance. Once the pores are filled with gas, the displacement of the electrolyte in the inter-electrode gap causes the big change in the cell resistance.

Although the discussion here does not necessarily “prove” the model, it does provide a means for interpreting the EIS data observed during the initiation of overcharge. In this section an attempt was made to generate some evidence for the model supporting the new paradigm.

Next, the new paradigm will be used to predict an effect that is somewhat startling. Specifically, the next study concerns itself with an oscillating electrochemical system. This could be an example of electrochemical chaos. The prediction of this effect follows directly from the new paradigm.

Case 3 – The electrically oscillating battery

A very interesting situation arises as one begins to speculate on the implications of this new model. There are physical consequences that are to be expected as the result of electrolyte displacement from within the inter-electrode gap. Specifically, the physical movement of the highly conductive electrolyte leaves gas filled voids that results in an increased resistance and, as a consequence, in increased IR drop within the cell.

One could envision a sequence of events that might occur in the following manner. That is, electrolyte movement acts so as to

- (1) increase the IR drop in the inter-electrode gap;
- (2) by holding constant battery voltage, this decreases the oxygen electrode potential;
- (3) the reduced electrode potential decreases the rate of the oxygen gas evolution reaction;
- (4) this reduction in the rate of gas evolution allows the electrolyte to flow back into the inter-electrode gap;
- (5) the consequence of this is a decrease in the cell resistance and the cell IR drop decreases;
- (6) this causes the rate of gas evolution to increase displacing more electrolyte;
- (7) the resistance of the cell increases
- (8) and the IR drop in the cell increases again.

From the preceding description, a dynamical model can be generated by, again, studying the response of the mathematical functions associated with the physical and chemical processes.[9] During overcharge the applied voltage can be written as:

$$V(\text{cell}) = E(\text{Pb}) + E(\text{O}_2) + IR$$

Solving for the oxygen electrode potential gives:

$$E(\text{O}_2) = V(\text{cell}) - E(\text{Pb}) - IR$$

Since:

- (a) $V(\text{cell})$ is a constant applied voltage
- (b) $E(\text{Pb})$ is depolarized by O_2 recombination

then

$$E(\text{O}_2) = k_1 - IR$$

The mathematical analysis of the dynamical system has been carried out and can be found in another place.[7] However, the intuitive awareness of the effect is clear. The IR drop plus the oxygen electrode potential is constant. As one increases the other must decrease. It is also noteworthy that these processes are nonlinear. That is, the current is exponentially related to the electrode potential and the current is also exponentially related to the applied temperature.

For the purposes of this paper, it is only necessary to say that under a certain set of conditions we can expect a sealed cell to develop oscillatory behavior. This, in fact, happens as shown in figures 6 and 7. Figure 6 reveals the oscillations as a function of the charge passing through the battery. Since the battery under test was rated at 120 Ah, it can be seen that a substantial overcharge has taken place.

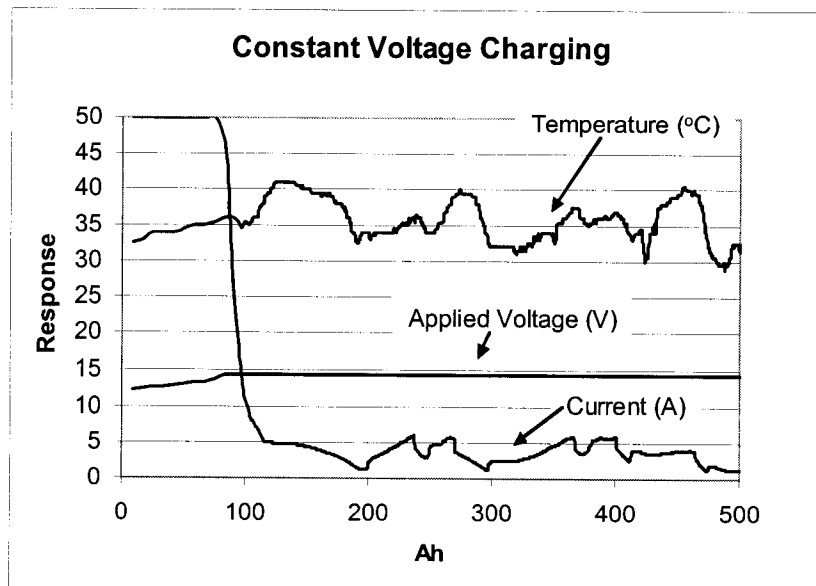

Figure 6. Temperature (measured at the negative terminal), current and applied voltage to the battery are shown as a function of charge passing through the battery.

Figure 7 shows the same data plotted against time which is the usual representation of the charging curve for a battery. This is another way of viewing the oscillatory behavior of the battery. It is note worthy that this oscillatory response occurs as a transition zone between stable performance and a complete thermal runaway. A more detailed discussion of the mathematical analysis can be found in another place. [7]

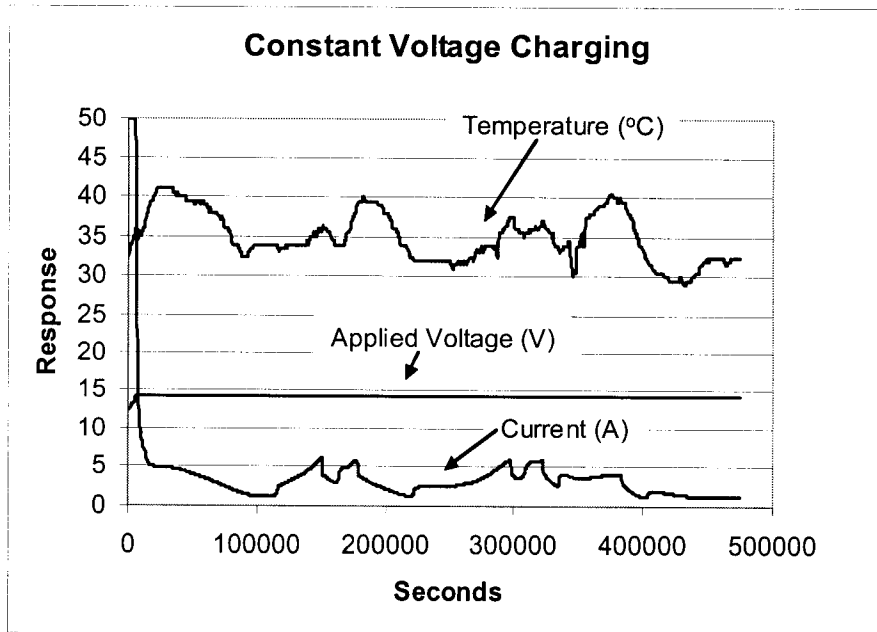

Figure 7. Temperature (measured at the negative terminal), current and applied voltage to the battery are shown as a function of time as the battery is charged.

Discussion of the power dissipation across the voltage gradient of the battery

An important part of the heat dissipation is the consequence of the passage of current across the voltage gradient established by the battery itself. Figure 8 is an equivalent circuit representation of a battery operated as an electrical load (not as a power source). The battery is in overcharge so no energy storage is taking place.

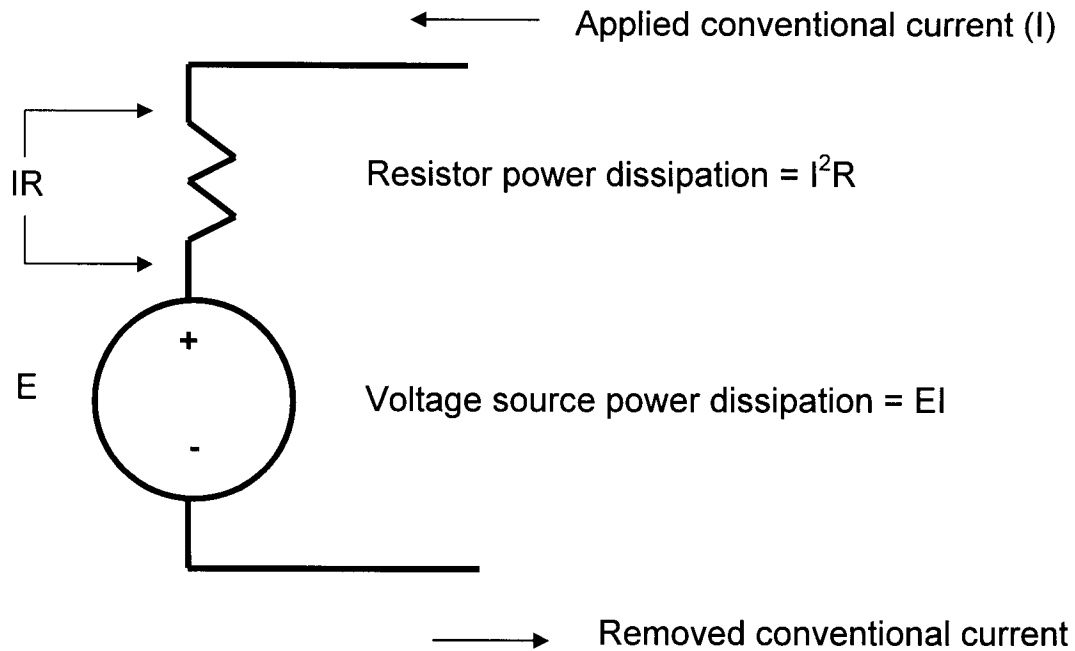

Figure 8. Equivalent circuit of a battery as an electrical load under steady state dc charging.

The graphic shows a classic Thevenin representation of a power source using linear components and the applied currents are being generated by another power source that is not shown.[10] Although the battery is inherently a power source, it is being affected as an electrical load. The key observation here is that there are two power dissipation components.[11] The first is the equivalent series resistance which corresponds to the polarization resistance of the battery. The second is the voltage gradient of the ideal voltage source that corresponds to the voltage of the battery at open circuit. Since the thought experiment involves no energy storage, the total dissipation is the sum of the power dissipated across the resistor plus the power dissipated across the voltage source. To get an idea of the relative magnitudes of these quantities, we can take the polarization resistance of a 12 volt battery to be 3 milli-Ohms. Assume that a 10 A current is passing. The power dissipation across this component is I^2R which is 0.3 W. The power dissipation across the voltage source is EI or 120 W. It would be nice to have a physical interpretation for this huge power dissipation but that interpretation may not involve claiming that the closed oxygen cycle is producing the heat. One plausible scenario is that the power dissipation is the consequence of the rate of change of the kinetic energy carried by the ions in the solution that are carrying the charge within the cell. The actual changes in their kinetic energy take place when the ion stops their forward motion by colliding with the electrode to which they are attracted. This collision would be the energy transfer mode serving to provide the path for power transfer. It is important to also point out that this power dissipation mechanism applies only when the battery is an electrical load. When the battery acts as a power source, the only element that is expected to serve as a power dissipating component is the polarization resistance. For example, a short circuited battery dissipates all of its power through the polarization

resistance. Note that this example is an ideal situation as the current carrying conductors are assumed to have no resistance. The preceding discussion appears to be a plausible interpretation.

Revisiting Figure 1, the Born-Haber Cycle.

Returning to one of the points made early in this paper, Figure 1 illustrates the rationale justifying the assertion that the closed oxygen cycle cannot generate any heat. Additionally, it also shows the two electrochemical steps identified by the enthalpies ΔH_2 and ΔH_4 . The specific reactions involved are:

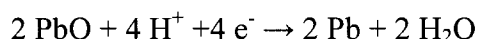
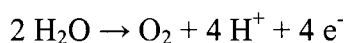

These reactions were written in this form to indicate that different electrode potentials are involved and that the electrons in the external circuit are replaced by hydrogen ions as the charge carriers within the cell. It is clear that the external circuit is doing work on the system to drive the hydrogen ions across a voltage gradient which is the difference between the two electrode potentials. Note that the oxygen molecules carry no charge so they are not involved directly in the power transfer. This discussion serves to indicate that the closed oxygen cycle serves as a power transfer conduit. The earlier discussion in this paper showed that the closed oxygen cycle is not involved in the heat generation process. The key distinction here lies in noting the fundamental difference between power and energy.

Conclusions

The above presentation argues for a new paradigm for interpreting the heat generation behavior of sealed cells on overcharge. It is understood that changing old ways of thinking is not easy. However, even if one does not accept the mechanism proposed, thinking about the implications of the new paradigm “explains a lot of things and makes the mathematics easier.”

An important implication from the above analysis is that a substantial portion of the heating effects appear to be associated with an electrolyte management issue within the separator.

Also, the hypothesized mechanism appears to be chemistry independent and should apply to cells having a constrained electrolyte that can be displaced by gas generated during charging (i.e., all sealed cells). The implications suggested by this interpretive perspective are broad in scope.

References

1. Kuhn, T., *The Structure of Scientific Revolutions*, University of Chicago Press, 1962.

2. Nelson, R., "The Basic Chemistry of Gas Recombination in Lead-Acid Batteries," JOM, 53 (1) (2001), pp. 28-33.
3. Berndt, D., Proceedings of the 10th International Telecommunications Energy Conference, San Diego, CA, USA, IEEE, 1988, pp.89-96.
4. Moseley, P.T. and D.A.J. Rand, Valve Regulated Lead-Acid Batteries, Elsevier, Boston, 2004, p. 10.
5. Pop, V., H. J. Bergveld, P. H. L. Notten and P. P. L. Regtien, State-of-the-art of battery state-of-charge determination, Institute of Physics Publishing, Meas. Sci. Technol. 16 (2005), pp. R93–R110.
6. Glasstone, S., Textbook of Physical Chemistry, second edition, D. Van Nostrand, NY, 1952, pp.204-206.
7. Catherino, H.A., Complexity in battery systems: Thermal Runaway in VRLA batteries, J. Power Sources, 2005, (available on line on Science Direct).
8. Macdonald, J.R. (ed.), Impedance Spectroscopy, John Wiley and Sons, New York, 1987.
9. Sanderfur, J.T., Discrete Dynamical Modeling, Oxford University Press, New York, 1993.
10. Hayt, W.H., and J.E. Kimmerly, Engineering Circuit Analysis, McGraw-Hill, 1986, p.85.
11. Sears, F.W, M.W. Zemanski and H.D. Young, University Physics, Sixth Edition, Addison-Wesley, Massachusetts, 1982, pp. 552-3.