

REPORT DOCUMENTATION PAGE

OMB No. 0704-0188

Public reporting burden for this collection of information is estimated to average 1 hour per response, including the time for reviewing instructions, searching data sources, gathering and maintaining the data needed, and completing and reviewing the collection of information. Send comments regarding this burden estimate or any other aspect of this collection of information, including suggestions for reducing this burden to Washington Headquarters Service, Directorate for Information Operations and Reports, 1215 Jefferson Davis Highway, Suite 1204, Arlington, VA 22202-4302, and to the Office of Management and Budget, Paperwork Reduction Project (0704-0188) Washington, DC 20503.

PLEASE DO NOT RETURN YOUR FORM TO THE ABOVE ADDRESS.

1. REPORT DATE (DD-MM-YYYY)	2. REPORT TYPE Final Technical Report	3. DATES COVERED (From – To) 01 May 2004 – 31 October 2006
-----------------------------	--	---

4. TITLE AND SUBTITLE Composite Sandwich Structures with Integrated Vascular Networks a Study Visit to UIUC to Initiate UK Collaboration and Coordination with 2005 MURI "Microvascular Autonomic Composites"	5a. CONTRACT NUMBER
	5b. GRANT NUMBER FA9550-06-1-0258
	5c. PROGRAM ELEMENT NUMBER

6. AUTHOR(S) Dr. Ian Bond	5d. PROJECT NUMBER
	5e. TASK NUMBER
	5f. WORK UNIT NUMBER

7. PERFORMING ORGANIZATION NAME(S) AND ADDRESS(ES) Advanced Composites Centre for Innovation and Science University of Bristol Department of Aerospace Engineering Queens Building, University Walk Bristol, BS8 1TR. UK.	8. PERFORMING ORGANIZATION REPORT NUMBER
--	--

9. SPONSORING/MONITORING AGENCY NAME(S) AND ADDRESS(ES) Air Force Office of Scientific Research (AFOSR) 875 N. Arlington St., Rm. 3112 Arlington, VA 22203 <i>Dr. Byung Ho Lee/NA</i>	10. SPONSOR/MONITOR'S ACRONYM(S) AFOSR
	11. SPONSORING/MONITORING AGENCY REPORT NUMBER N/A

12. DISTRIBUTION AVAILABILITY STATEMENT
DISTRIBUTION A: Approved for public release. Distribution is unlimited. AFRL-SR-AR-TR-07-0161

13. SUPPLEMENTARY NOTES

14. ABSTRACT
This report details two study visits undertaken by University of Bristol researchers to the University of Illinois at Urbana-Champaign between 13th - 17th March 2006 and 5th - 9th February 2007 to discuss collaboration on MURI activities and broader self-healing work. During the first visit (see Agenda/Itinerary in Appendix 1 and 2), the programme of work started with two days of discussions and presentations by UIUC researchers and a seminar by the Bristol team on their current work. A day of laboratory activities and familiarization was interspersed with these activities. Time for consolidation allowed the generation of several areas for future collaboration.

15. SUBJECT TERMS

16. SECURITY CLASSIFICATION OF:			17. LIMITATION OF ABSTRACT	18. NUMBER OF PAGES	19a. NAME OF RESPONSIBLE PERSON
a. REPORT Unclassified	b. ABSTRACT Unclassified	c. THIS PAGE Unclassified	Unclassified	93	19b. TELEPHONE NUMBER (Include area code) (703)



Report of study visits by

University of Bristol, UK

to

University of Illinois in Urbana-Champaign, USA

**to initiate collaboration and coordination with
2005 MURI “MICROVASCULAR AUTONOMIC
COMPOSITES”.**

Prepared by Dr. Ian Bond

**Advanced Composites Centre for Innovation and Science,
University of Bristol,
Department of Aerospace Engineering,
Queens Building, University Walk,
Bristol, BS8 1TR. UK.**

Tel: +44(0)117 928 7704 Fax: +44(0)117 927 2771

Email: I.P.Bond@bristol.ac.uk



Introduction

This report details two study visits undertaken by University of Bristol researchers to the University of Illinois at Urbana-Champaign between 13th - 17th March 2006 and 5th – 9th February 2007 to discuss collaboration on MURI activities and broader self-healing work.

During the first visit (see Agenda/Itinerary in Appendix 1 and 2), the programme of work started with two days of discussions and presentations by UIUC researchers and a seminar by the Bristol team on their current work. A day of laboratory activities and familiarisation was interspersed with these activities. Time for consolidation allowed the generation of several areas for future collaboration.

This report aims to summarise the key areas of discussion and ongoing plans for collaboration and research exchange.

Topics of discussion

Hollow fibres: Hollow glass fibres of around 60 microns external diameter have been used extensively in previous work at Bristol and have been shown to release healing agent in an impact event via fibre fracture. Hollow glass fibres could themselves be considered a simple form of vascular network that is easily integrated into a composite laminate. Discussions highlighted how hollow glass fibres provide a significant storage volume for repair agents.

Outcome: Several possible methods of encouraging more complete resin bleed-out were suggested for further investigation by brainstorming sessions with different UIUC researchers.

Previous characterisations of the hollow fibres has focussed on the axial properties. Fibre behaviour under crushing and crack-fibre interaction are areas that require further research. Experimental and modelling studies undertaken at UIUC on individual microcapsules have many features that could be applied to hollow fibres.

An exchange of information and experimental practice is underway to help characterise the out-of-plane hollow fibre response. In particular, the following aspects will be considered;

- Crushing of hollow fibres
- Modelling of crack/fibre interaction
- Hollow fibre wall thickness vs. toughness requirements
- Fracture toughness: Mode I, II, mixed mode
- Healing resin/matrix interface post-healing.

Microcapsules: Work at UIUC has shown microcapsules to be a very effective method of self-healing to recover fracture toughness. In particular, recent work has shown this approach has much to offer in a fatigue environment, where experiment has shown a propagating crack is attracted to the microcapsule, cleaving it and initiating the release of monomer. A potential limitation of the microcapsule system is the limited volume of self-healing agent available for

addressing impact damage where the crack is opened to create free volume. The combination of microcapsules and hollow fibres offer great potential as a method of addressing issues of both impact and fatigue, in particular, growth of a fatigue crack initiated by an impact event.

Consideration was given to how hollow fibres & microcapsules may be combined for maximum benefit;

Route 1: Fibres & microcapsules addressing different damage modes (fibres > impact; capsules > fatigue cracks).

Route 2: Microcapsules containing 'catalyst', hollow fibres supply resin.

Route 3: Capsules in skin-core bond of sandwich structures supplied by vascular network (subset of Route 1 or 2?)

Other ideas for expanding the use of microcapsules with high performance composites included;

- Microcapsules within aerospace composite prepreg
- Use of low Temp. cure prepreg (e.g. Advanced Composite Group's LTM series, from 30°C!)
- Use of NCF's & RTM processing methods

A variety of test methods for evaluating self-healing efficacy were considered;

- Compression after impact: modified Boeing method (Prichard & Hogg)
- Fatigue after impact: tension/compression/flexure?

Healing Resins: Urea-formaldehyde encapsulated DCPD has proved to be a successful system, although the Grubbs' catalyst requires careful preparation and protection to ensure activity. Various discussions were had concerning the potential for adapting and improving commercial two-part epoxy systems (currently favoured for resin filled hollow fibre healing) to make them more suitable as a healing agent. In particular, the following properties were considered;

- viscosity,
- wetting (of substrate)
- cure schedule (Temp. & Time),
- mechanical properties after cure,
- longevity within substrate.

Also, discussion was given to the alternatives and future development of a multi-component healing system, and the advantages/disadvantages that were likely to be conferred e.g

- liquid resin + liquid hardener
- liquid resin + solid catalyst
- catalysts/accelerants/suppressants.....
- equilibrium/precipitation reactions,
- catalysed depolymer'n
- chemical "markers" to indicate successful healing (How do you interrogate?)
- sealing of penetration damage i.e. breached pressure vessel vs. moisture ingress;
- expanding foams (pressurised system ⇔ sealing rather than healing)

Vascular Networks: Work at UIUC has focussed on healing tension cracks in epoxy coatings via an underlying material containing a microvascular network of channels of around 200 microns diameter. This network is formulated by a direct-write process. Thermal control of materials using the microvascular network to circulate fluid is also an area of active research.

Vascular healing in practical composite sandwich structures is being investigated by Bristol researchers under three themes: Vascular network architecture and fabrication, circulatory devices and mechanical characterisation. Manufacturing practicalities and resin supply pressure has driven the use of vessels of 1.5mm bore. Preliminary studies have focussed on manufacturing a simple architecture, manually injecting pre-mixed resin and characterising the recovered flexural strength and failure mode. The vascular self-healing for sandwich structures has been introduced to stabilise a composite skin disbonded by impact damage. Early work has shown an almost complete recovery of flexural strength and promotes final failure remote from the site of impact damage. The vascular self-healing being investigated by Bristol provides:

- An approach using larger vessels than the UIUC work. This is suited to the supply of large volumes of repair agent to typical impact damage modes.
- An application driven approach targeted at typical damage modes in practical aircraft structures.
- A manufacture approach using conventional composite manufacturing techniques.
- An extension to include an integrated pumping capability; this does not form part of the current MURI activities.
- An extension to investigate thermal control of composite sandwich panels using a vascular network, although at different application scales.

This visit has therefore identified that there is little duplication in the work being carried out at UIUC and Bristol. The study areas are indeed complimentary. There are areas of significant overlap offering opportunities for future collaboration as both our work progress. Possible areas are:

- Optimising the network layout and vessel diameters to supply regions of damage in a self-healing application. Damage volume and response time are likely to be key variables.
- Modelling and optimising the network layout and vessel diameters to achieve efficient thermal control in the respective target applications.

Other ideas to be addressed in future studies include;

- Use of vascular networks in thermal management,
- Use of hollow Z-pins for through-thickness healing in laminates & sandwich cores,
- Development and application of circulatory pump device to facilitate healing resin flow (issues such as pressure, flow rate, power etc....)

Other self-healing approaches and applications: Self-healing in elastomeric materials using encapsulated PDMS is targeted at thin film applications such as improving interfacial bonding in car tyres. This could have potential for biomedical applications. Incorporating PMMA microcapsules in bone cement is an area of active research at UIUC. This could also have applications for self-healing in dental components, an area in which collaboration is underway at Bristol.

New research at Bristol is considering how to restore the integrity of a leaking pressure vessel following penetrative impact event. The use of an expanding foam healing agent has been investigated. This could be combined with a vascular delivery to enable larger holes to be filled.

Collaborative activities

1. Study of self-healing composite using microcapsules and hollow fibres. Options for evaluation include;
 - A two-part epoxy system with the resin contained in the fibres and an encapsulated amine hardener.
 - A two-part epoxy system with a mixture of hollow fibres and capsules containing both parts.
 - A DCPD system with dispersed catalyst and DCPD monomer contained in both fibres and capsules, designed to initiate self-healing under different damage modes.
 - A DCPD system with the catalyst held in suspension in either fibres or capsules to provide catalyst penetration into material cracks.

UIUC contribute extensive experience in encapsulating a variety of components for inclusion in a composite laminate. Bristol provide extensive facilities and understanding in the manufacture of high quality hollow glass fibres and composite laminates.

2. Characterisation of hollow glass fibres crushing and fracture characteristics for direct comparison with microcapsules is a second area where collaboration would be mutually beneficial. The analysis and experimental characterisation of sub-millimetre structures that has been applied so successfully to microcapsules by UIUC could be applied to hollow glass fibres manufactured using the bespoke facilities at Bristol.
3. Mechanical testing (Compression After Impact) of self-healing fibre reinforced composites (comprising either microcapsules or hollow fibres) has highlighted some unusual findings. Thus, ongoing discussions are taking place for both institutions to agree on and employ similar test methods to allow a comparison of performance and ensure true measures of self-healing efficacy.
4. In both institutions, vascular self-healing (and thermal management) is at an early stage. The approaches and drivers investigated are complementary but focussed on different applications. Whilst UIUC are investigating the direct fabrication of microvascular networks in-situ, Bristol are concentrating on creating networks at a macro scale within

both composite sandwich structures and laminates. Exchange of manufacturing techniques and mechanical test methods is underway to facilitate knowledge transfer and accurate performance comparisons.

5. The key to successful collaboration is ongoing exchange of personnel. To this end, plans are underway to facilitate a variety of exchanges of research staff and postgraduate students via several funding mechanisms. These include EPSRC, NSF, World Universities Network, UK Royal Academy of Engineering, and both Bristol and UIUC.

Objectives Achieved

- Familiarisation with MURI aims and objectives.

The work on vascular networks, both in sandwich structures and in the form of hollow glass fibres compliments the existing MURI research topics.

- Familiarisation with relevant UIUC technologies.

Microcapsule manufacture, direct write assembly for microvascular networks, fracture toughness characterisation approach.

- Detail areas of research to which Bristol can directly contribute.

Hollow glass fibres to provide healing agent volume, experience in application driven composite manufacturing, vascular healing for large damage volume in sandwich structures or for penetration damage sealing.

- Prepare and agree programme of Bristol work packages which contribute to proposed MURI activities.

Three primary areas of collaboration have been identified, and regular communication and exchange of information is ensuring mutual benefit.

Recent and Forthcoming Publications:

As an outcome of the various philosophical discussions from these collaborative visits, a recent publication was prepared by the Bristol participants that considered the broader concepts of self-healing and what future directions it may take.

*Trask RS, Williams HR, Bond IP (2007); **Self-healing polymer composites: mimicking nature to enhance performance.** Bioinspiration & Biomimetics. Vol. 2, No. 1 (2007) pp. 1-9. (doi:10.1088/1748-3182/2/1/P01)*

An idea which arose during discussions was for Dr. Bond and Professor's White and Sottos to initiate and guest edit a special themed issue on 'self-healing polymers and composites' in the Journal of the Royal Society Interface [<http://www.pubs.royalsoc.ac.uk/interface>]. The intention of

this effort was to highlight the current state of the art in the field and raise the general profile of *self-healing* in the scientific community.

Journal of the Royal Society Interface is a relatively new international journal publishing articles from the interface between the physical sciences, including mathematics, and the life sciences. It provides a high-quality forum to publish rapidly and interact across this boundary in two main ways: J. R. Soc. Interface publishes research applying chemistry, engineering, materials science, mathematics and physics to the biological and medical sciences; it also highlights discoveries in the life sciences that allow advances in the physical sciences.

Eight authors (see below) were invited to contribute papers in their specialism related to self-healing of polymers and composites. These were then reviewed and collated for incorporation in a special issue of the journal due to be published in April 2007.

*Trask RS, Williams GJ, Bond IP (2007); **Bioinspired Self-Healing Of Advanced Composite Structures Using Hollow Glass Fibres.** J. Roy. Soc. Interface – Special Issue: Self Healing Materials. Accepted - In Press. (doi: 10.1098/rsif.2006.0194)*

*Jones AS, Rule JD, Moore JS, Sottos NR, White SR (2007); **Life extension of self-healing polymers with rapidly growing fatigue cracks.** J. Roy. Soc. Interface – Special Issue: Self Healing Materials. Accepted - In Press. (doi: 10.1098/rsif.2006.0199)*

*Mauldin TC, Rule JD, Sottos NR, White SR, Moore JS (2007); **Self-healing kinetics and the stereoisomers of dicyclopentadiene.** J. Roy. Soc. Interface – Special Issue: Self Healing Materials. Accepted - In Press. (doi: 10.1098/rsif.2006.0200)*

*Williams KA, Boydston AJ, Bielawski CW (2007); **Towards electrically conductive, self-healing materials** J. Roy. Soc. Interface – Special Issue: Self Healing Materials. Accepted - In Press. (doi: 10.1098/rsif.2006.0202)*

*Kersey FR, Loveless DM, Craig SL (2007); **A hybrid polymer gel with controlled rates of cross-link rupture and self-repair** J. Roy. Soc. Interface – Special Issue: Self Healing Materials. Accepted - In Press. (doi: 10.1098/rsif.2006.0187)*

*Kalista SJ and Ward TC (2007); **Thermal characteristics of the self-healing response in poly(ethylene-co-methacrylic acid) copolymers** J. Roy. Soc. Interface – Special Issue: Self Healing Materials. Accepted - In Press. (doi: 10.1098/rsif.2006.0169)*

*Verberg R, Dale AT, Kumar P, Alexeev A, Balazs AC (2007); **Healing substrates with mobile, particle-filled microcapsules: designing a ‘repair and go’ system.** J. Roy. Soc. Interface – Special Issue: Self Healing Materials. Accepted - In Press. (doi: 10.1098/rsif.2006.0165)*

*Hayes SA, Jones FR, Zhang W, Hou L (2007); **Quantitative evaluation of solid-state self-healing in composites.** J. Roy. Soc. Interface – Special Issue: Self Healing Materials. Accepted - In Press.*

APPENDIX 1:**A STUDY VISIT TO INITIATE COLLABORATION AND COORDINATION WITH UIUC'S 'AUTONOMIC HEALING MATERIALS' ACTIVITIES.**

**Beckman Institute, UIUC, IL
Monday 13th March – Friday 17th March**

Provisional Agenda/Discussion Outline**Mon 13th March – Wed 15th March:**

- Introductions – Bristol/UIUC teams
- Seminar giving overview of Bristol activities followed by open discussion – IPB
- Familiarization with UIUC facilities/activities/meet the teams

- Vascular networks - how our work can fit in with MURI;
 - Self-healing: Scale and drivers.
 - Thermal management. Scale in application.
 - Z-pins (through-thickness healing in laminates & sandwich cores)
 - Pumps (pressures, resin flow). Circulating vs. static pressure?

- Healing resin selection;
 - Methods to improve existing commercial resin systems:
 - viscosity,
 - cure schedule (Temp & Time),
 - Mechanical Properties (surface energy influences)
 - Life expectancy.
 - Two-part liquid vs. resin + solid catalyst.
 - Development of future resin systems;
 - Blue Skies ideas: Equilibrium/Precipitation reaction, Catalysed Depolymerisation
 - Chemical “markers” to indicate successful healing.
 - How do you interrogate?

- Fracture Mechanics;
 - Crushing of hollow fibres
 - Modelling of crack/fibre interaction
 - Hollow fibre wall thickness vs. toughness requirements
 - Fracture toughness: Mode I, II, mixed mode?
 - Healing resin/matrix interface post-healing.

- Hollow fibres & microcapsules combined;
 - Route 1: Use fibres and microcapsules to address different damage modes within the same structure (fibres: impact; capsules: fatigue crack growth).

- Route 2: Use microcapsules to contain polymerisation triggers, use hollow fibres to supply resin.
- Route 3: Capsules in skin-core bond of a sandwich structure supplied by vascular network, could use for subset of either Route 1 or 2!

- Microcapsules within aerospace grade composite prepreg
 - Use of low temperature curing prepreg (ACG's LTM series, from 30°C!)
 - Use of NCF's & RTM processing methods
- Compression after impact: Modified Boeing method (Prichard & Hogg)
- Fatigue after impact: tension/compression/flexure?

- Self-sealing (Gross damage i.e. breached pressure vessel vs. small scale moisture ingress);
 - Expanding foams (pressurised system to give sealing rather than healing)

- Self-healing fibres;
 - The development of new composite materials required (nanofibres to impart healing?)
 - Nanofibres "coiled" in microcapsules that unravel when the fibre is breached: produces a fibrous scab.

Also "Must do" before end of visit:

- Sort/edit self-healing review paper (in print before Intern'l Conference - Spring 2007?)
- Proc Roy Soc special issue – prepare/send invitation letters, establish timescale for actions.
- Discussions to establish collaborative work plan(s)
- Identify Funding mechanisms/targets. [e.g. <http://www.darpa.mil/baa/baa06-19mod1.html>]

Thur 16th March:

Nominally free to allow for any overrun and report preparation.

Final Deliverable:

A report detailing the outcomes of the research study visit and the areas for further collaboration between UIUC and Bristol will be prepared and circulated to all and submitted to AFOSR upon the completion of the visit.

APPENDIX 2:**UIUC Itinerary**

Ian Bond, Richard Trask, Hugo Williams
Dept. of Aerospace Engineering
University of Bristol

March 11, 2006 (Saturday)

Arrival in Champaign, free time, Engineering Open House (9:00-3:00pm, Engineering Campus; <http://eoh.ec.uiuc.edu>)

March 12, 2006 (Sunday)

12:00 pm Lunch – meet at Hampton Inn (Magnus Andersson)
 2:30 pm Illini Basketball game* (bar w/ TV – Magnus will help)
 7:00 pm Dinner (TBD) [S. White, M. Andersson]

March 13, 2006 (Monday)

9:00 am Overview and planning meeting (3369 BI)
 [N. Sottos, S. White, I. Bond, R. Trask, H. Williams]
 10:00 am Chemical signaling, healing chemistry (3321 BI) [J. Moore]
 10:30 am free
 12:00 noon Self-Healing @ Bristol Seminar (2369 BI) [UIUC group]
 1:00 pm Brainstorming session (2369 BI) [P. Geubelle]
 2:00 pm Healing resin options (4055 BI) [J. Rule]
 3:00 pm Combined capsule/fiber for impact damage (319m Talbot)
 [Amit Patel]
 4:00 pm AE Seminar (103 Talbot Lab)
 [“Reversal physics: creation of negative material properties,” Rod Lakes, U. of Wisconsin]
 6:00 pm Dinner (Kofusion)
 [R. Lakes, S. White, N. Sottos, I. Bond, J. Freund]

March 14, 2006 (Tuesday)

9:00 am Self-healing prepreg (4055 BI) [O. Aramagan]
 10:00 am Foams and other concepts (3369 BI) [N. Sottos]
 11:00 am free.....microencapsulation training (3317 BI; A. Patel)

12:00 noon	Lunch (Campustown) [White]
1:00 pm	Self-Healing Review Paper work session (3369 BI) [S. White]
2:30 pm	Self-Healing Group Meeting (3369 BI) [UIUC group]
4:00 pm	informal interactions (4055 BI); microencapsulation training (3317 BI: A. Patel)
??	Dinner (TBD)

March 15, 2006 (Wednesday)

9:00 am	Royal Society Spec. Issue work session (3369 BI) [N. Sottos]
9:00 am (all day)	Microencapsulation training (3317 BI) [A. Patel]
10:00 am	free
11:00 am	Self-cooling & pumping (4055 BI) [L. Shipton]
12:00 noon	Lunch (TBD)
1:00 pm	free
3:00 pm	Regroup/planning (3369 BI) [S. White]
5:30 pm	NanoCEMMS Reception and Poster Session (West Pavilion, Grainger Library) [N. Sottos, B. Blaiszik]
7:00 pm	Dinner (TBD)

March 16, 2006 (Thursday)

morning	TBD
12:00 noon	Lunch (TBD)
afternoon	TBD
4:00 pm	TAM Seminar (103 Talbot Lab) [“Size effects and idealized dislocation microstructures at small scales,” Amit Acharya, Carnegie Mellon University]
5:00 pm	Krannert Uncorked (Lobby, Krannert Center) [S. White]
6:30 pm	Dinner (TBD)

March 17, 2006 (Friday)

Morning	TBD
11:30 am	Lunch (TBD)
12:30 noon	Leave for Chicago



The Advanced Composites Centre
for Science & Innovation
University of Bristol
Queen's Building
University Walk
Bristol BS8 1TR
United Kingdom
+44 (0) 117 928 7704

composites-centre@bristol.ac.uk
www.bris.ac.uk/composites

www.bris.ac.uk/composites

SELF-HEALING COMPOSITES

– hollow fibre approach

*Dr. Richard Trask, Gareth Williams,
Hugo Williams, Dr. Ian Bond*
*University of Bristol, Department of Aerospace Engineering,
Queen's Building, University Walk, Bristol, BS8 1TR, UK*

[Contact: R.S.Trask@bristol.ac.uk]



Self-Healing @ Bristol
UIUC Seminar 13th March 2006



Where is Bristol?

- 115 miles due west of London
- Bristol has been a port for 1000 years.
- By mid-18th century, Bristol was England's 2nd city.
- After the 'discovery' of America, Bristol was the main point of departure for voyages to the New World.

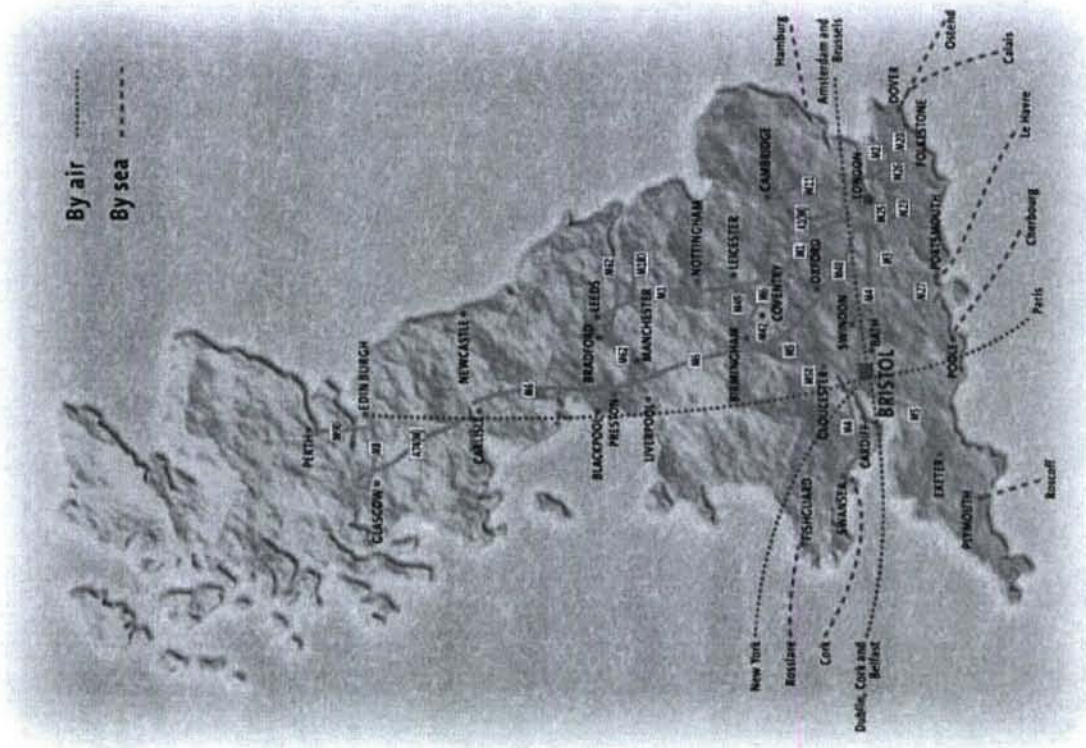

The City of Bristol

3



- A modern city with a long history.
- Population ~500,000.
- Flourishing centre for a wide range of artistic & sporting activities.

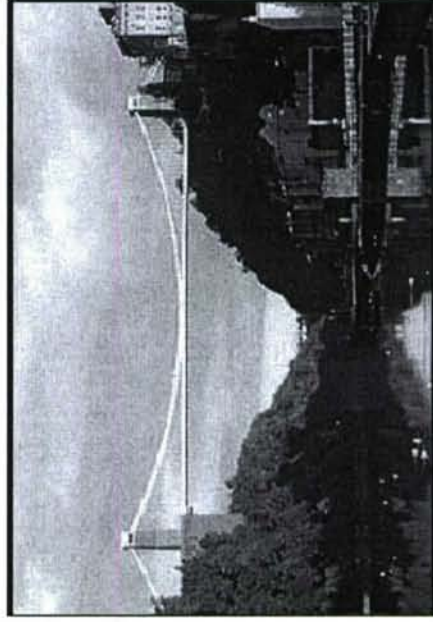
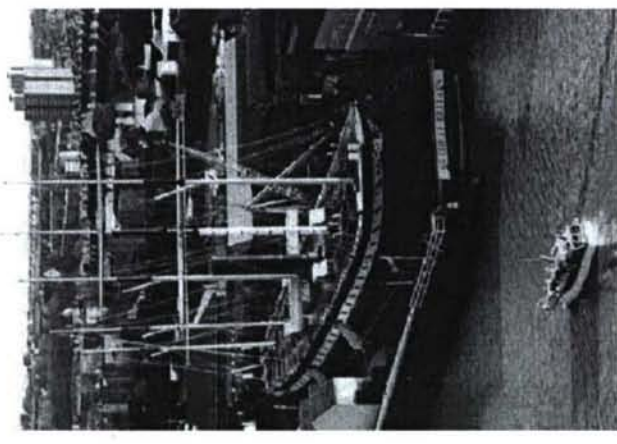

The University of Bristol

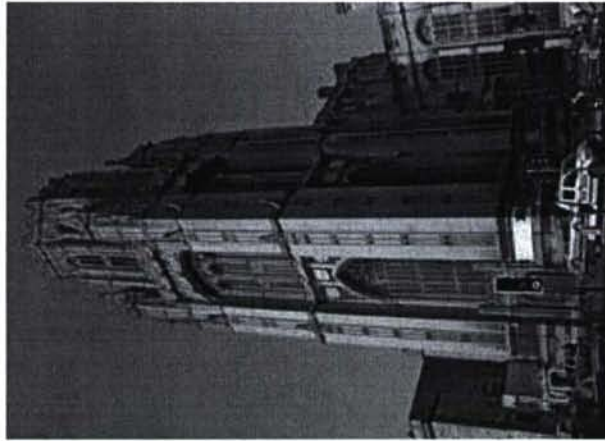

- **Royal Charter 1909**
 - Bristol Medical School (1833)
 - University College, Bristol (1876)
 - Merchant Venturers' Technical College (1894)
- **A broad-based university in the city centre.**

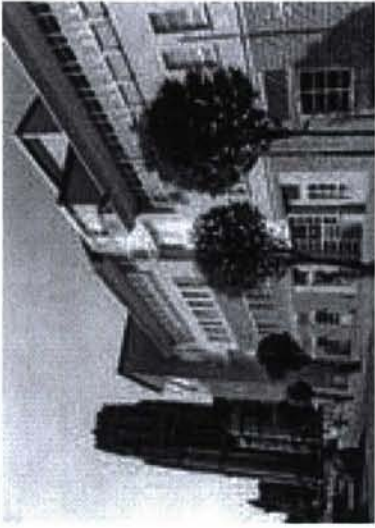

- **~16,000 students**
- **6 Faculties: Arts, Engineering, Medical & Veterinary Sciences, Medicine & Dentistry, Science, Social Sciences & Law**



Industry around Bristol

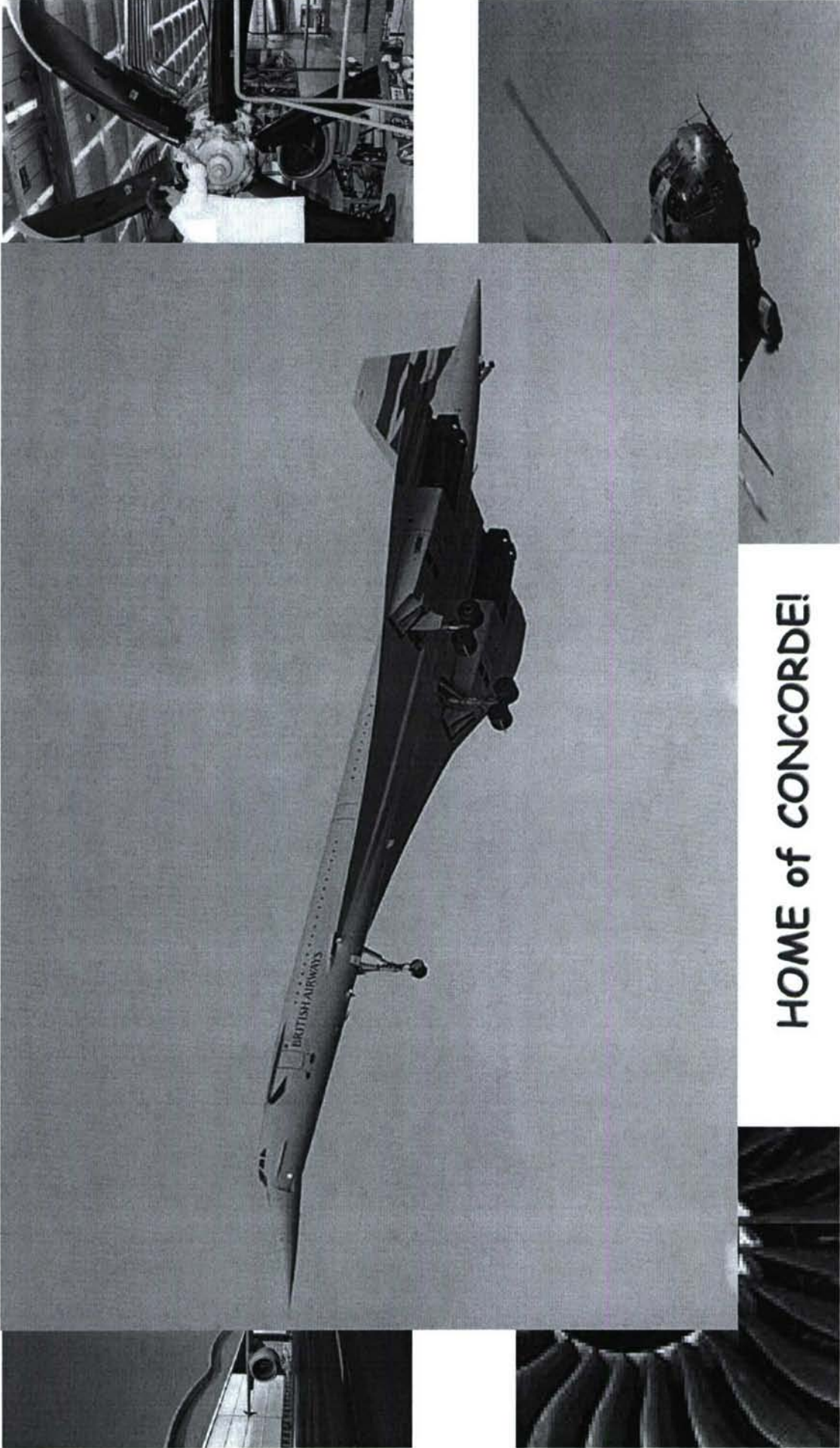

HOME of CONCORDE!

Contents

- Overview of Hollow Fibre Self-Healing
- Research Status
 - Self-Healing GFRP
 - Self-Healing CFRP
- Concluding Remarks

Self-Healing Composites

7

- During damage the fibres rupture, resin bleeds into damage zone and effects repair.
- The release of resin mimics the bleeding mechanism in biological organisms.
- Hollow glass fibres offer the advantage of combining structural reinforcement and storage of self-repair components.
- Use single-part, or two-part resin and hardener, or resin with a catalyst/hardener contained within the matrix material or ????

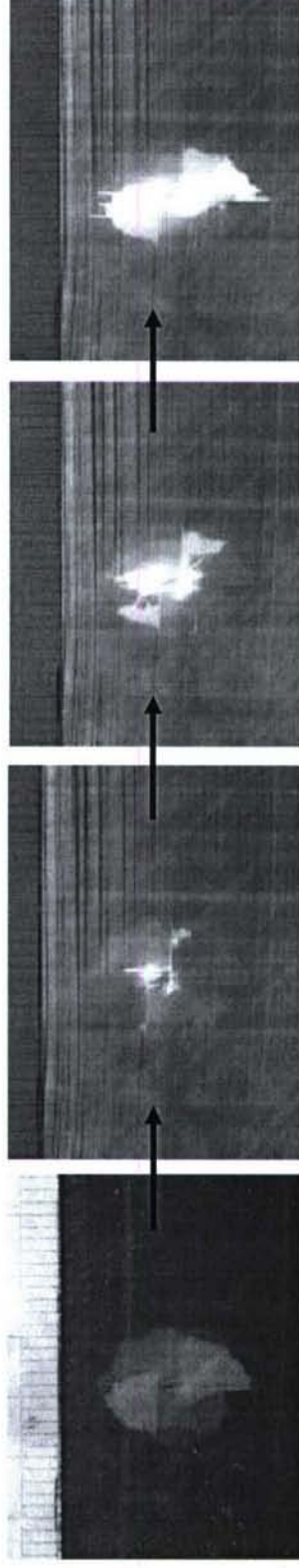

E-glass/913 epoxy
(16 ply [0°/45°/90°/-45°]2s) with self-healing plies at +45°/90° interfaces above the mid-plane and in the -45°/90° interfaces below the mid-plane subject to impact event.

Self-Healing GFRP Composites

Self-Healing GFRP Composite

- Project Title.
 - Enabling Self-Healing Capabilities – A Small Step to Bio-Mimetic Materials (ESA/ESTEC Contract No. 18131/04/NL/PA).
- Project Aims.
 - The aim of this study is to verify the self-healing concept in LEO and to enable its use for future space missions from a materials engineering viewpoint.

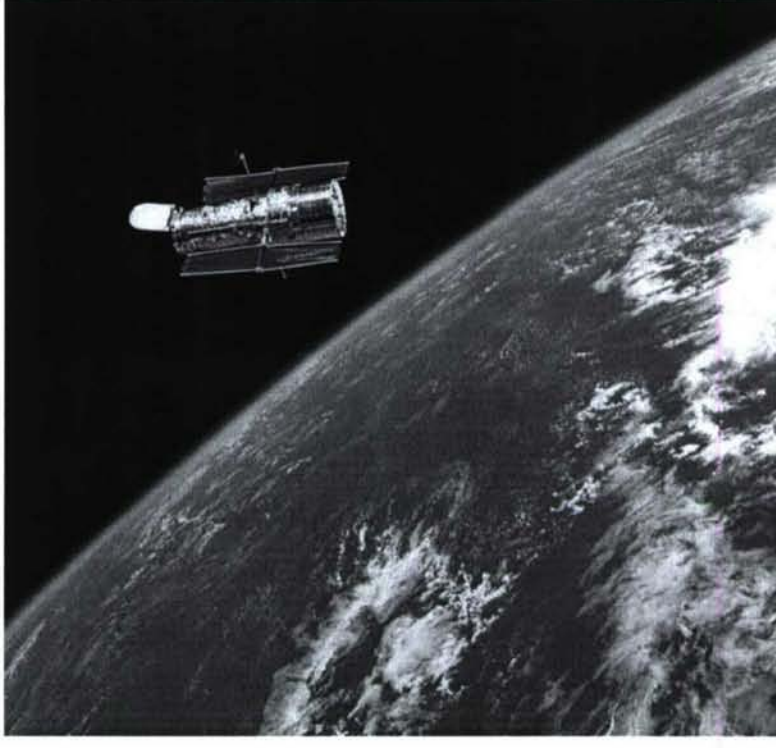

The Hubble Space Telescope (HST) in Low Earth Orbit

http://www.esa.int/esaCP/SEMQKMMZCIE_index_0.html

Self-Healing Composite: Fibre Manufacture

- Fibre tower schematic

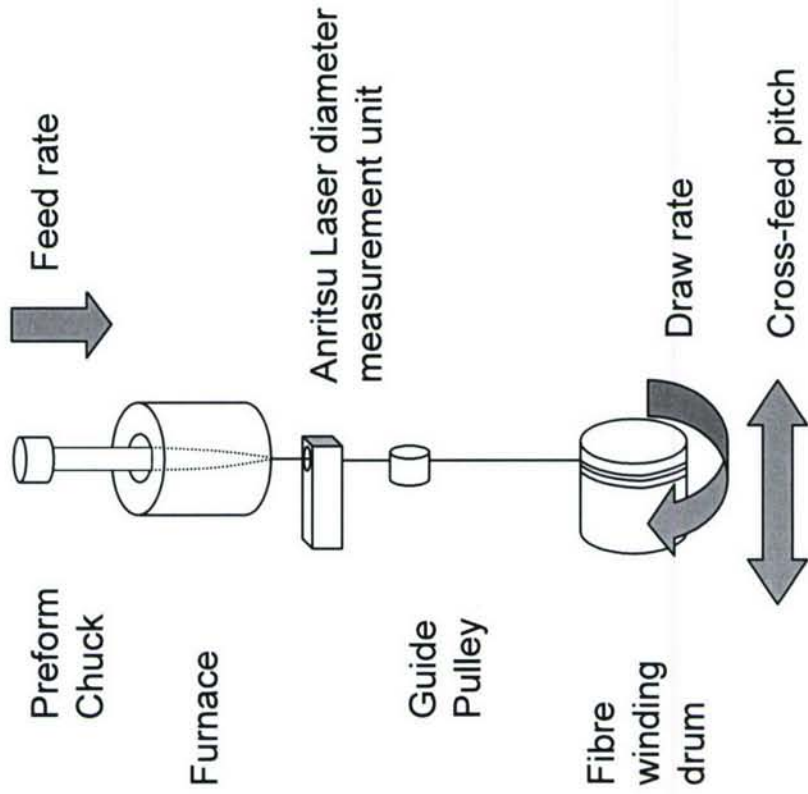

- Infiltration schematic

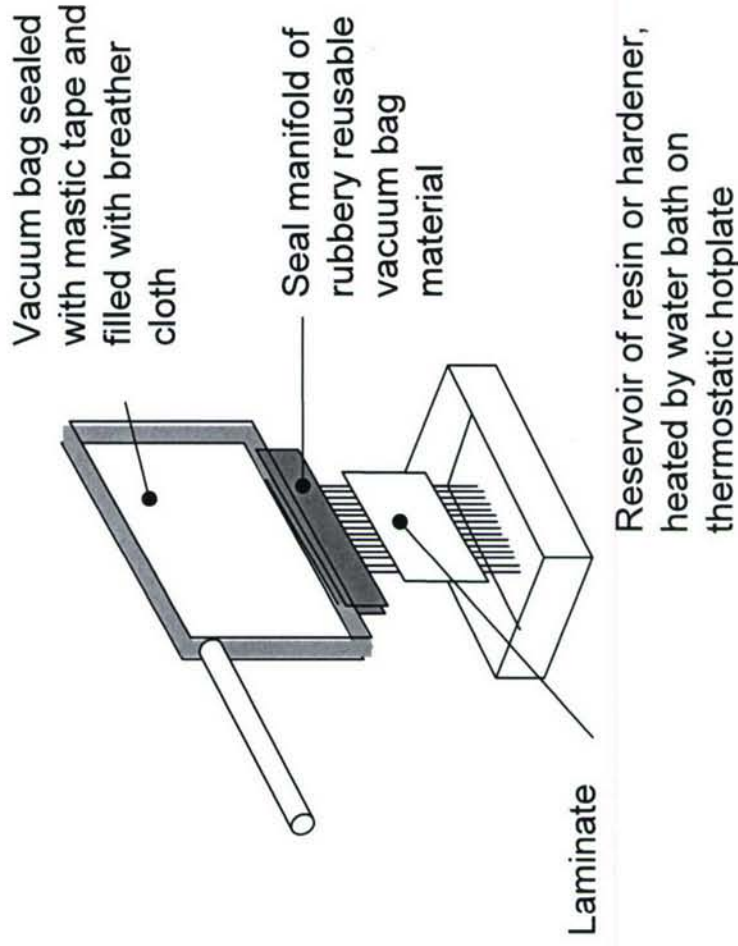

Self-Healing Composite: Consolidation

11

- 60 μm diameter, 55% hollowness
- Hollow fibre sealing
 - High-temperature, high modulus silicone sealant
- Hollow fibre orientation within laminate
 - Resin and hardener aligned in the same ply

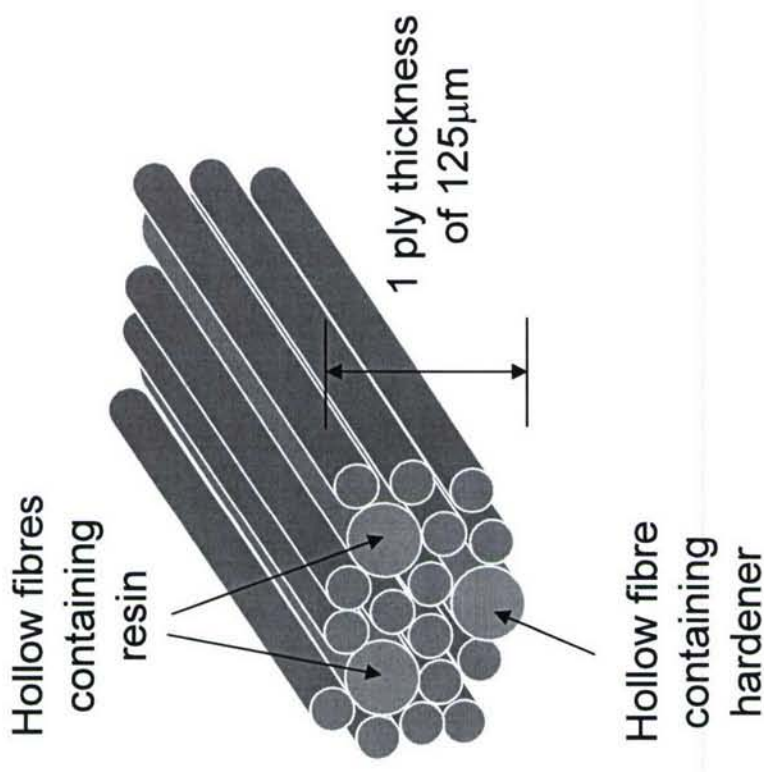

Self-Healing GFRP Composite

- The damage is introduced into 16 ply $[0^\circ/45^\circ/90^\circ/-45^\circ]_{2s}$ E-glass/913 by loading the sample in three-point bend with round-nosed impactor.

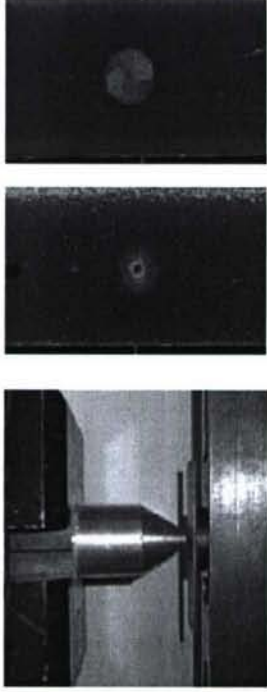

Indentation (1400N) ↓

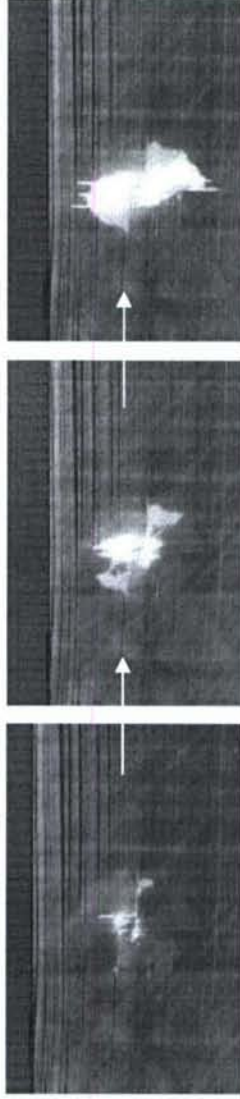

Damage formation within E-glass/913 epoxy (16 ply $[0^\circ/45^\circ/90^\circ/-45^\circ]_{2s}$) with self-healing plies at $+45^\circ/90^\circ$ interfaces above the mid-plane and in the $-45^\circ/90^\circ$ interfaces below the mid-plane. 60 μ m OD hollow fibres containing Cycom 823 epoxy resin + UV dye

Self-Healing Composite: Healing Infusion

No UV →
illumination

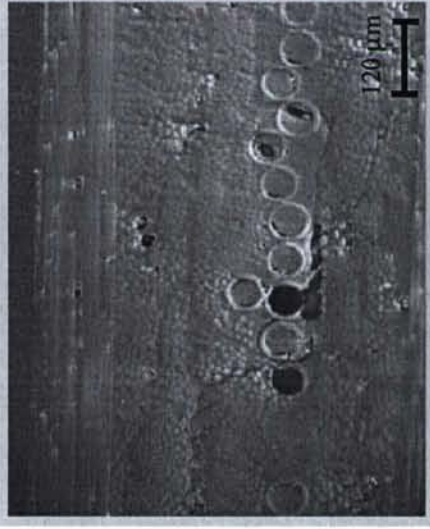
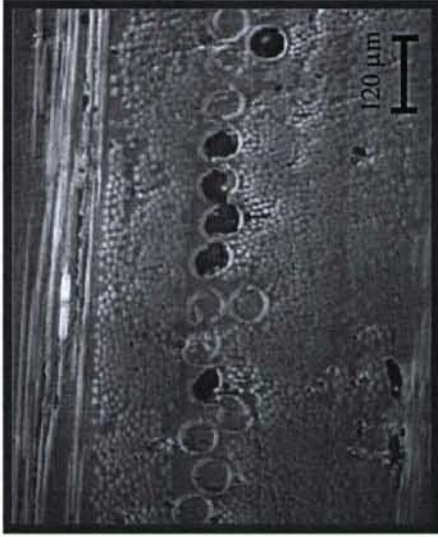

0°

+45°

90° & Self Heal

-45°

UV →
illumination

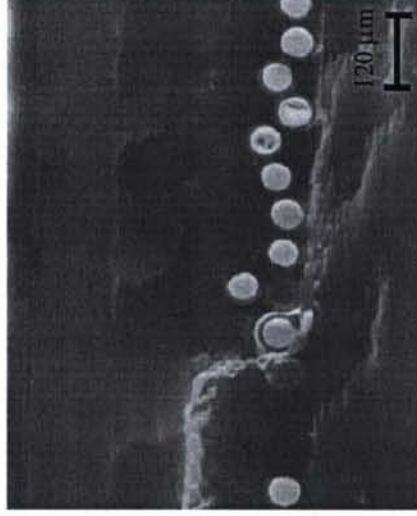
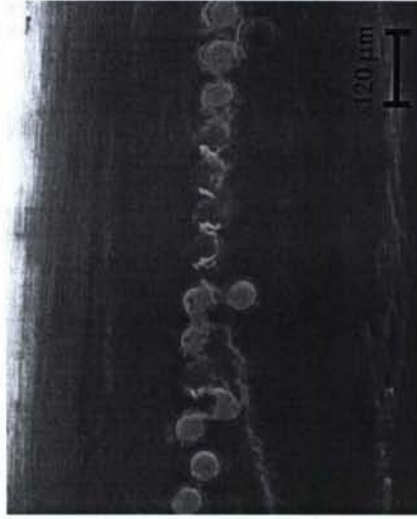

16 ply [0°/45°/90°/-45°]_{2s} E-glass/913 epoxy with self-healing plies.
60μm OD hollow fibres containing Cycom 823 epoxy resin + UV dye

Self-Healing GFRP Composite

14

16 ply $[0^\circ/45^\circ/90^\circ/-45^\circ]_{2s}$ E-glass/913 epoxy with self-healing plies at $\pm 45^\circ/90^\circ$ interfaces

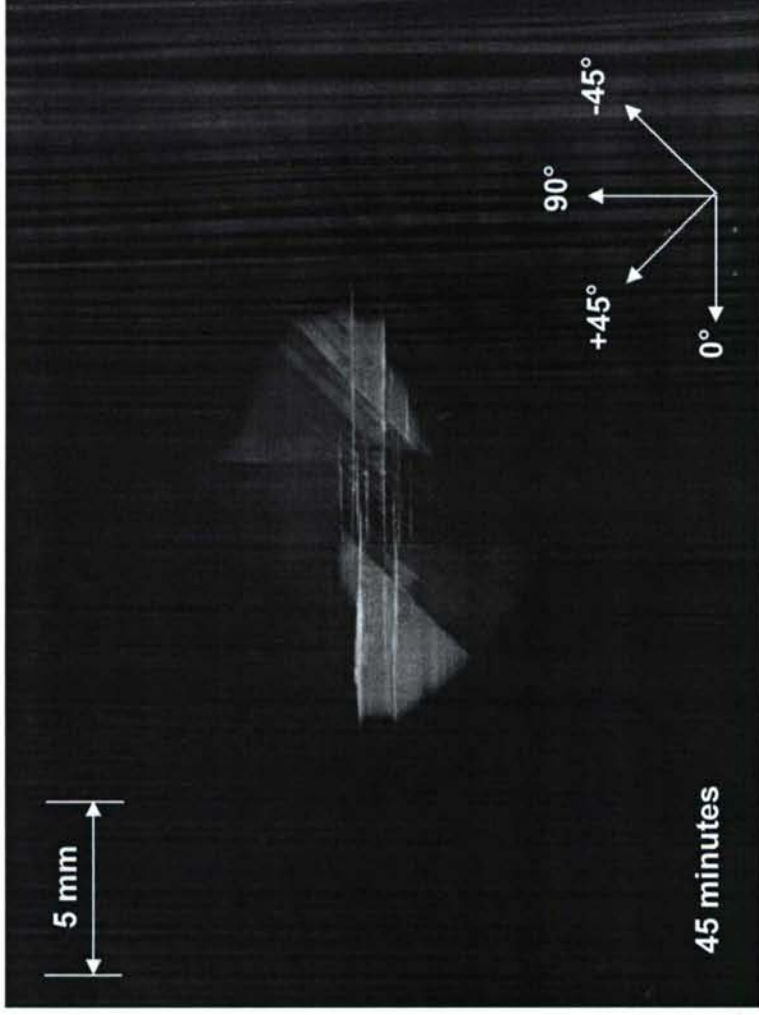

Time lapse photography showing Cytec 823 epoxy resin and hardener with UV dye infiltrating the damage site at 90°C

Self-Healing GFRP Composite: Strength Restoration

Mean flexural strengths under four-point bend test (D6272 - 02).
Note: Error bars show one standard deviation

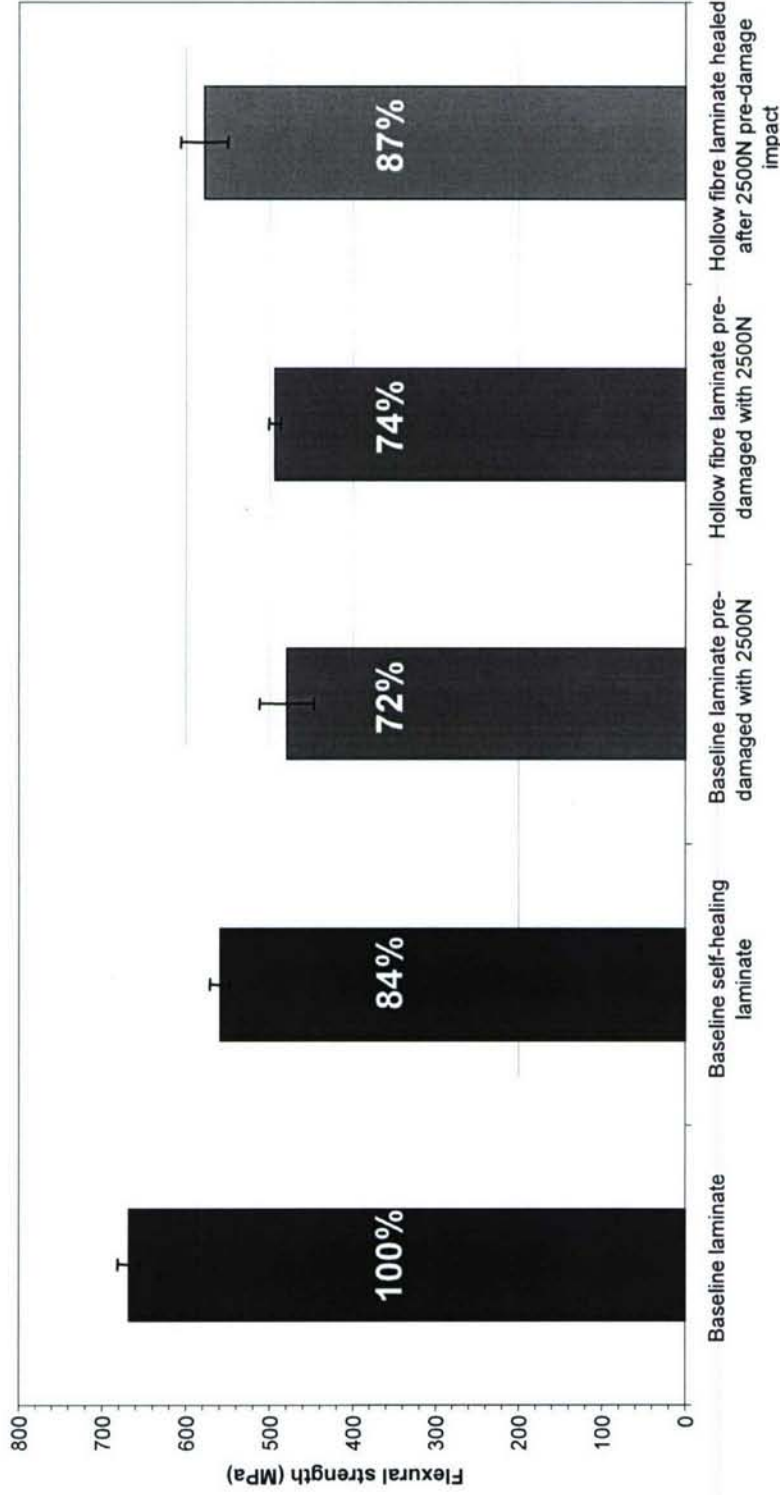

Self-healing laminate had a healed strength recovery of:

- **87%** compared to the ultimate failure strength of an undamaged baseline laminate
- **100%** compared to the ultimate failure strength of the undamaged **hollow fibre** laminate.

Self-Healing CFRP Composite

Self-Healing CFRP Composite

17

- The aim is to develop a self-healing process suitable for Carbon Fibre Reinforced Plastics.
- Optimise hollow fibre spacing to match threat
- Mechanical property assessment (flexure & CAI)
- C-scanning
- Fracture toughness (Mode I & II)

Self-Healing CFRP Composite

18

60 μ m HGF
spacing within
a 16 ply
[-45°/90°/+45°/0°]_{2s}
CFRP
(T300/914)

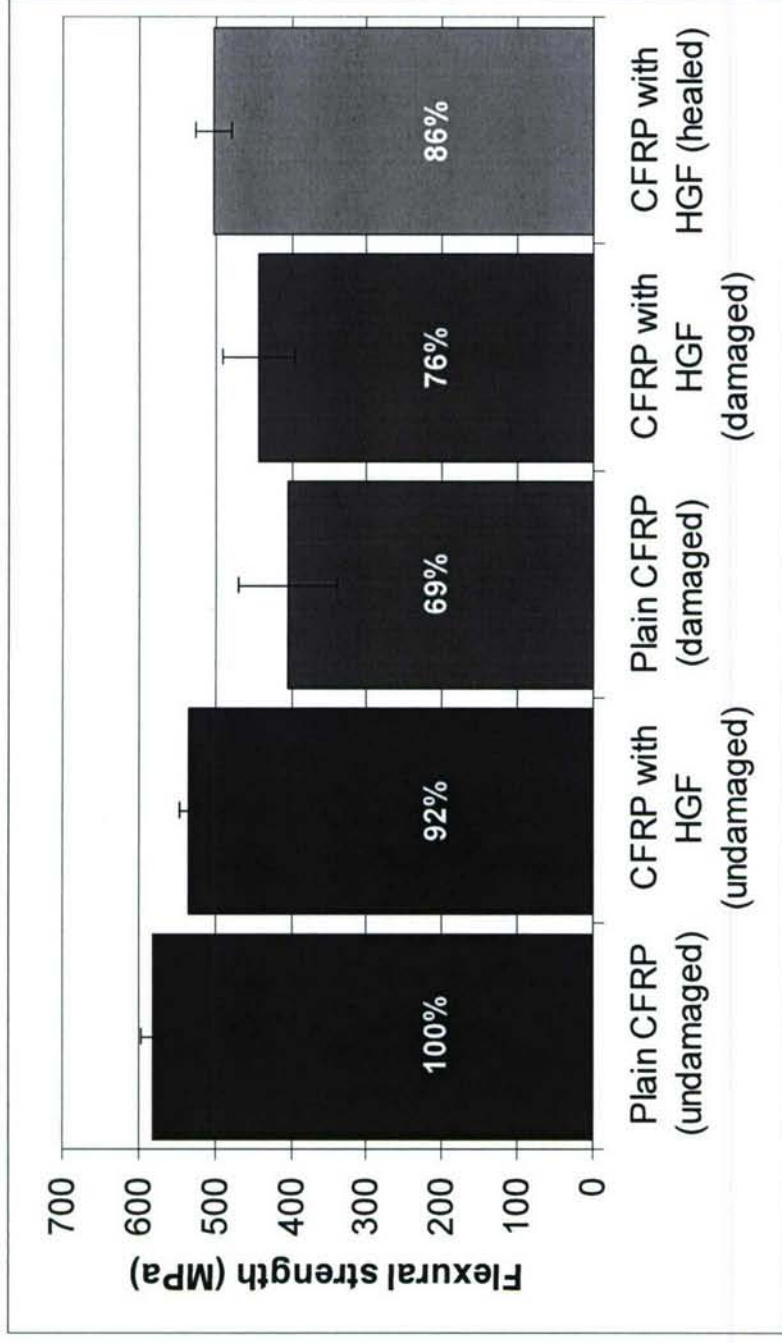

60 μ m HGF @ 70 μ m spacing

Concluding Remarks

Concluding Remarks

- A hollow-fibre self-healing approach can be used for the repair of advanced composite laminates and sandwich structures.
- This approach permits the placement of self-healing plies and vascular network to match the damage threat and minimise the disruption on the structural composite material
- Strength restoration in composite laminates has been demonstrated;
 - Healing efficiency ~87% baseline GRP laminate (using Cycom 823)
 - Healing efficiency ~86% baseline CFRP laminate (using Cycom 823)

Self-Sealing Composite Materials

**David Lewin, Alex Miles, Hugo Williams,
Dr. Richard Trask, Dr. Ian Bond**

*University of Bristol, Department of Aerospace Engineering,
Queen's Building, University Walk, Bristol, BS8 1TR, UK*

[Contact: I.P.Bond@bristol.ac.uk]

Drivers

22

- Severe impact damage (e.g. ballistic impact) - loss of integrity in a pressure vessel.
- May constitute a 'structural' failure
- Self-sealing mechanisms are common (e.g. fuel tanks) BUT self-sealing material may offer weight saving.

Possible Solution

23

- Use a foaming resin system stored in hollow fibres to seal fluid flow path.
- Two-part PUR selected with 1:4 and 1:18 expansion ratios.

Impact Damage

- Hemispherical impactor driven through laminate under displacement control
- Water pressure used to demonstrate seal effectiveness



Vascular Self-Healing Composite Sandwich Structures

***Hugo Williams, Dr. Richard Trask,
Dr. Ian Bond***

*University of Bristol, Department of Aerospace Engineering,
Queen's Building, University Walk, Bristol, BS8 1TR, UK*

[Contact: Hugo.Williams@bristol.ac.uk]

Drivers

- **Research Literature view:**
 - Experimental and Modelling studies: up to 50% loss in residual compressive strength caused by impact damage.
 - Even significant skin-core debonding can exist with very little visual indication of damage.
- **Application view:**
 - Sandwich structures extensively used in secondary aerospace and primary marine structures.
 - Several drivers for widening their use.
 - Current repair techniques involve excising damaged skin and core and bonding in replacements: effective but time consuming.

Aim and Objectives

27

- **Aim**
 - To introduce a self-healing ability into a typical advanced composite sandwich structure via a vascular network.
- **Objectives**
 - Embed a simple vascular network within a sandwich core and demonstrate the release of a healing agent into damage under pressure.
 - Quantify the undamaged, damaged and healed flexural strengths of impacted vascular sandwich beams.
 - Produce a technology demonstrator panel showing an integral healing agent accumulator to pressurise a network and allow autonomous self-healing.

Impact Damage

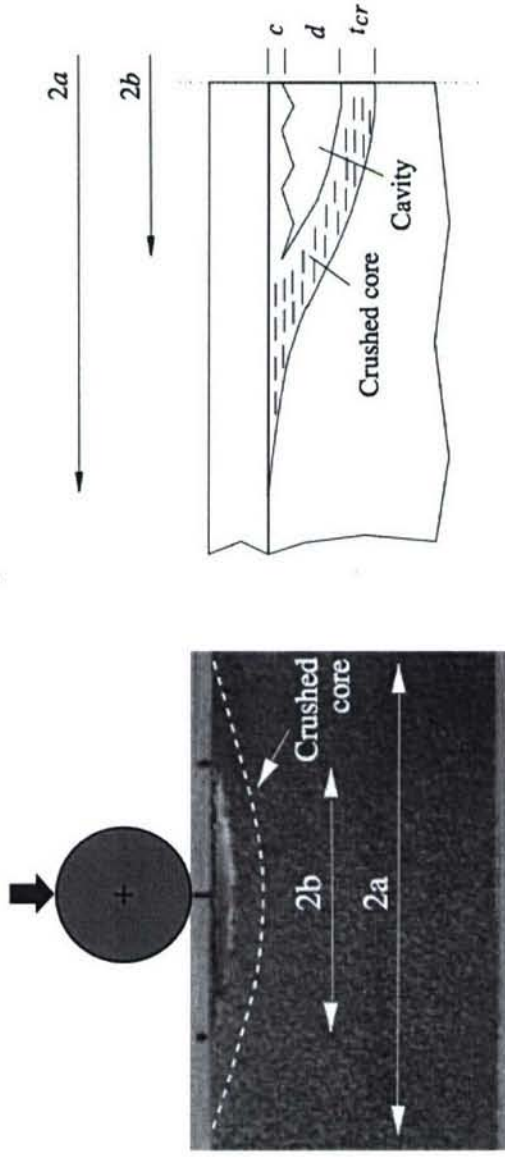

Shipsha et al, 2003. *J. Sand. Struct.* **5**

- Initially, impact damage simulated using a static load on a hemispherical head impactor.

Vascular Sandwich Production

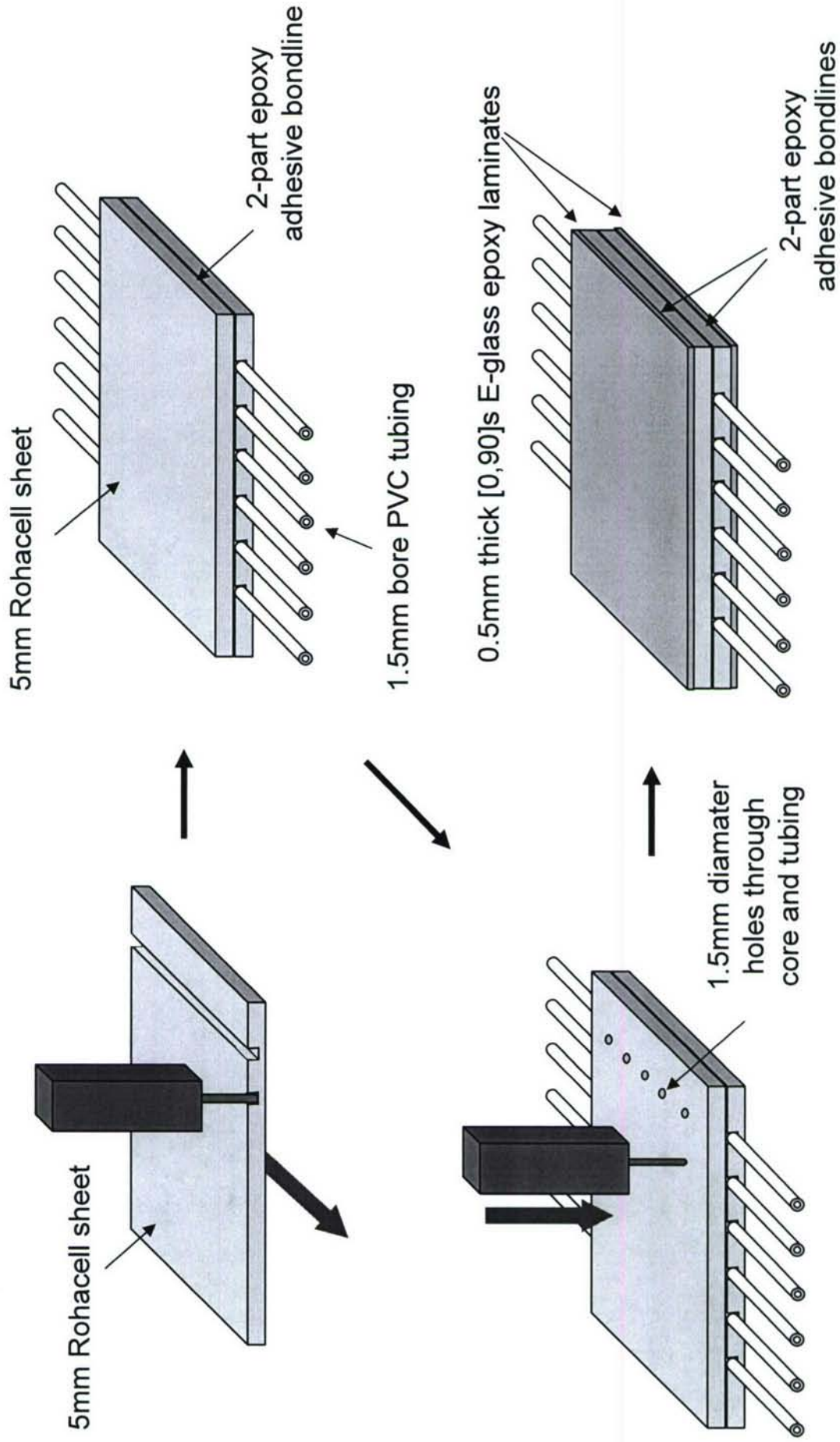

Qualitative Investigation

- Samples manufactured with vascular networks.
- Network filled with premixed two-part epoxy resin system (SPSystems Ampreg 20) mixed with UV dye.
- Network pressurised using static head to approximately 3800 Pa (= 1.1 inches Hg)
- Samples indented, sectioned and polished.

Qualitative Investigation 2

31

450N point indentation



Quantitative Testing

- Beam specimens impacted using cylindrical drop weight ($\sim 3\text{J}$) across sample width.

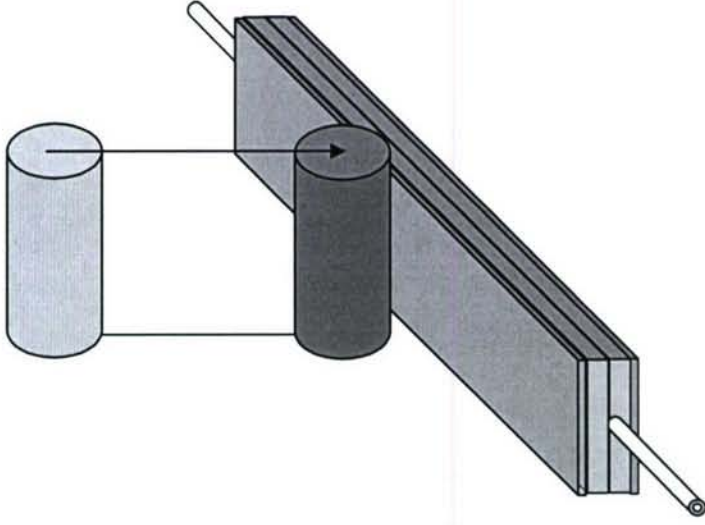

Quantitative Testing

- Beam specimens impacted using cylindrical drop weight (~3J) across sample width.

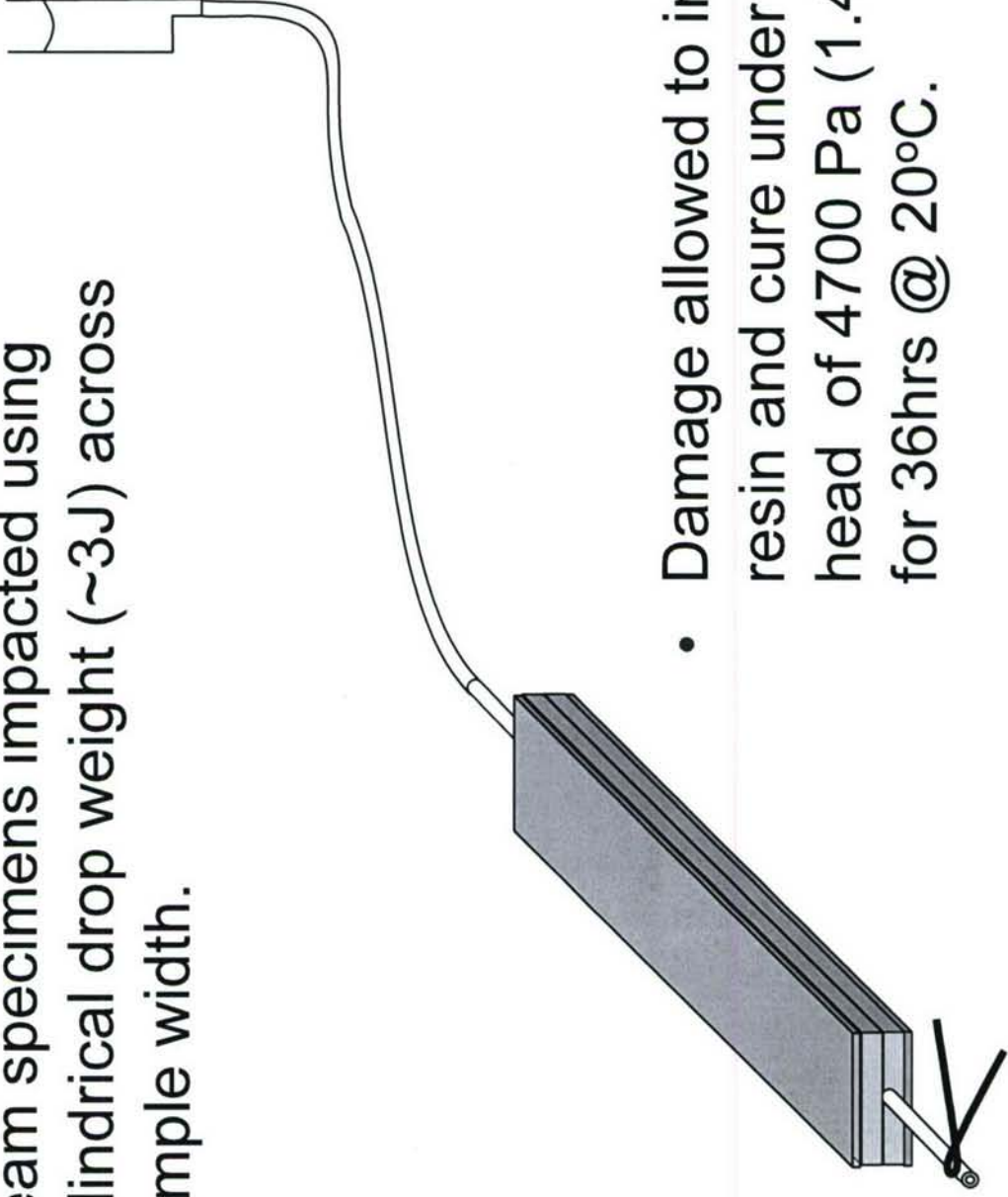

- Damage allowed to infuse with resin and cure under a pressure head of 4700 Pa (1.4 inches Hg) for 36hrs @ 20°C.

Results

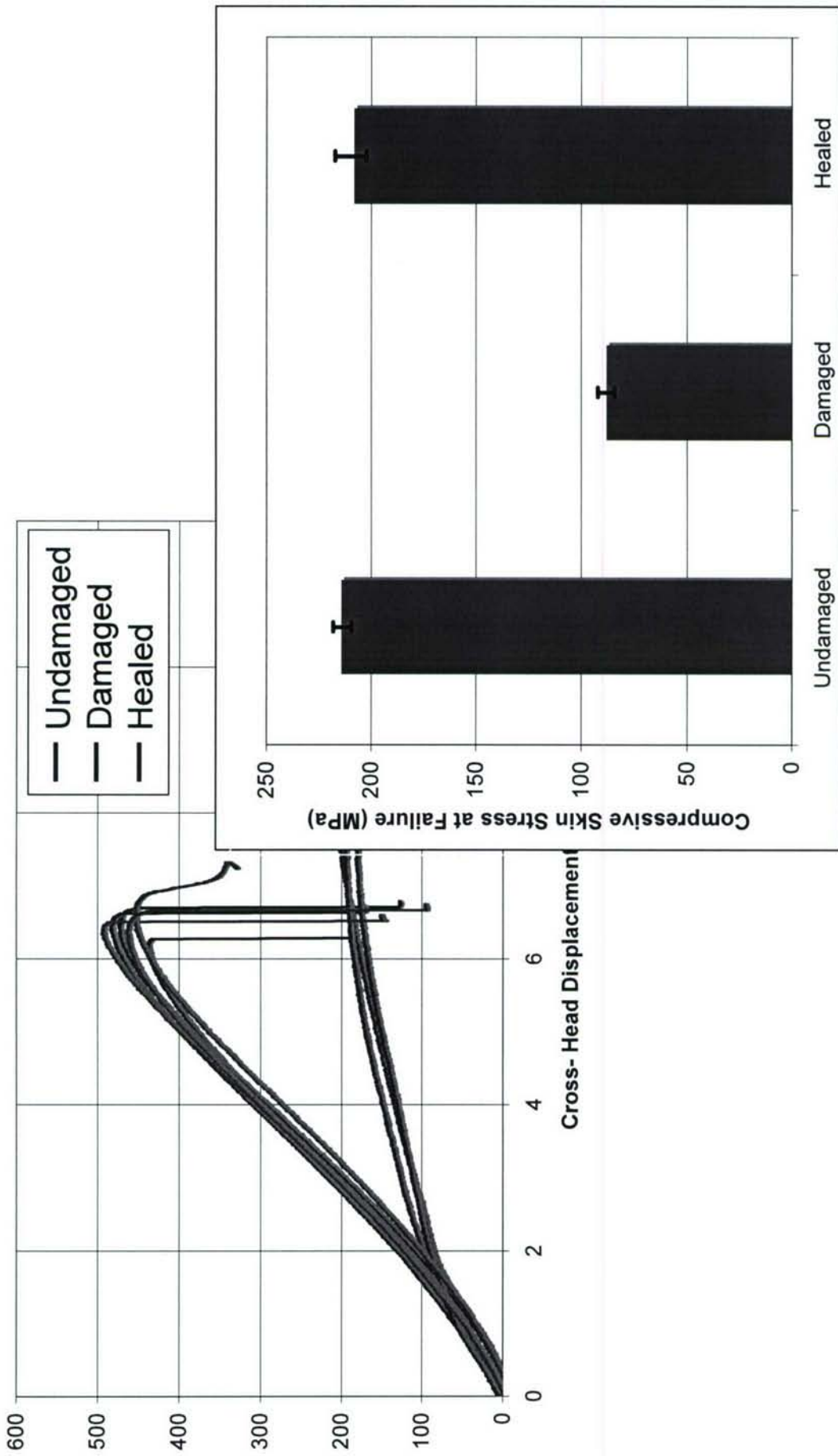

Failure Modes

- Undamaged

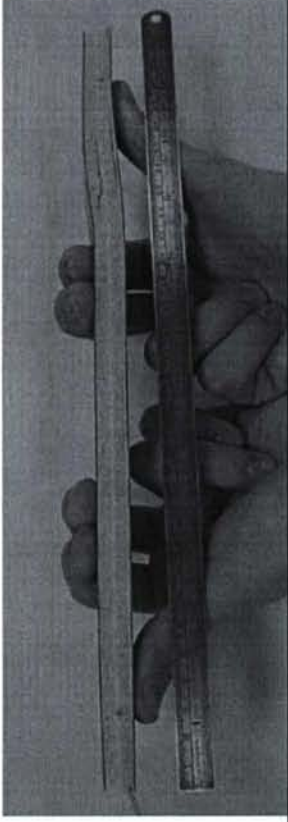

Core Shear

- Damaged



Skin buckling

- Healed

Core Shear

Concluding Remarks

- A viable manufacturing scheme for a vascular sandwich structure has been developed.
- Infusion of damaged sandwich core through a vascular network under a static head has been demonstrated.
- Mechanical testing has shown recovery of flexural strength and restoration of undamaged failure mode in healed specimens.

Future Work

37

- Evaluate effect of network on Core shear properties
- Manufacturing refinements
- Selection of resin system for autonomous self-healing
- Open or closed circuit healing agent flow from integral reservoir
- 3D panel damage and network design.

UIUC/Bristol Interaction

38

- Healing resin selection;
 - Methods to improve existing commercial resin systems:
 - viscosity,
 - cure schedule (Temp & Time),
 - mechanical properties (surface energy influences)
 - life expectancy.
 - two-part liquid vs. resin + solid catalyst.
 - Development of future resin systems;
 - Blue Skies: equilibrium/precipitation reaction, catalysed depolymer'n
 - Chemical "markers" to indicate successful healing.
 - How do you interrogate?
- Fracture Mechanics;
 - Crushing of hollow fibres
 - Modelling of crack/fibre interaction
 - Hollow fibre wall thickness vs. toughness requirements
 - Fracture toughness: Mode I, II, mixed mode?
 - Healing resin/matrix interface post-healing.

UIUC/Bristol Interaction

39

- Hollow fibres & microcapsules combined;
- Route 1: Fibres & microcapsules address different damage modes (fibres > impact; capsules > fatigue cracks).
- Route 2: Microcapsules contain 'catalyst', hollow fibres supply resin.
- Route 3: Capsules in skin-core bond of sandwich structure supplied by vascular network (subset of Route 1 or 2?)
- Microcapsules within aerospace composite prepreg
 - Use of low T cure prepreg (e.g. ACG's LTM series, from 30°C!)
 - Use of NCF's & RTM processing methods
- Compression after impact: modified Boeing method (Prichard & Hogg)
- Fatigue after impact: tension/compression/flexure?
- Self-sealing;
- Gross damage i.e. breached pressure vessel vs. small scale moisture ingress;
- Expanding foams (pressurised system ► sealing rather than healing)
- Vascular networks; (how can Bristol work fit in with MURI?)
 - Self-healing: Scale and drivers.
 - Thermal management. Scale in application.
 - Z-pins (through-thickness healing in laminates & sandwich cores)
 - Pumps (pressures, resin flow). - circulating vs. static pressure?

Self-healing composites – fibres, networks and resins

Dr. Ian Bond

Advanced Composites Centre for Innovation and Science (ACCIS),
University of Bristol, Department of Aerospace Engineering,
Queen's Building, University Walk, Bristol, BS8 1TR, UK

[Contact: I.P.Bond@bristol.ac.uk]

www.aer.bris.ac.uk/research/fibres or
www.bristol.ac.uk/composites

Research Update:

2

- Self-Healing CFRP
- Vascular Networks
 - Sandwich structures
 - Laminates
- Optimising Healing Resins

Bristol Healers!



Self-Healing Composites: Recap

- During damage the fibres rupture, resin bleeds into damage zone and effects repair.
- The release of resin mimics the bleeding mechanism in biological organisms.
- Hollow glass fibres offer the advantage of combining structural reinforcement and storage of self-repair components.
- Choice of healing resin systems

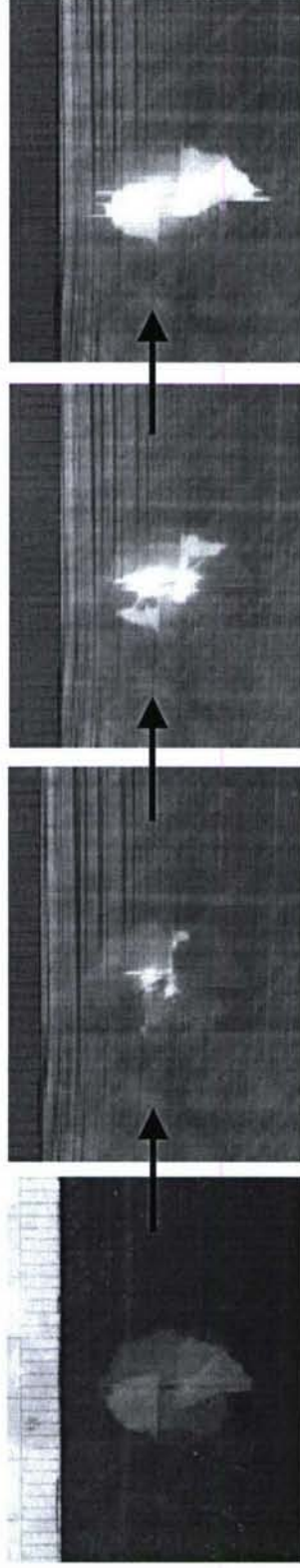

E-glass/913 epoxy
(16 ply [0°/45°/90°/-45°]2s) with self-healing plies at +45°/90° interfaces above the mid-plane and in the -45°/90° interfaces below the mid-plane subject to impact event.

Self-Healing Composite: Fibre Manufacture

- Fibre tower schematic

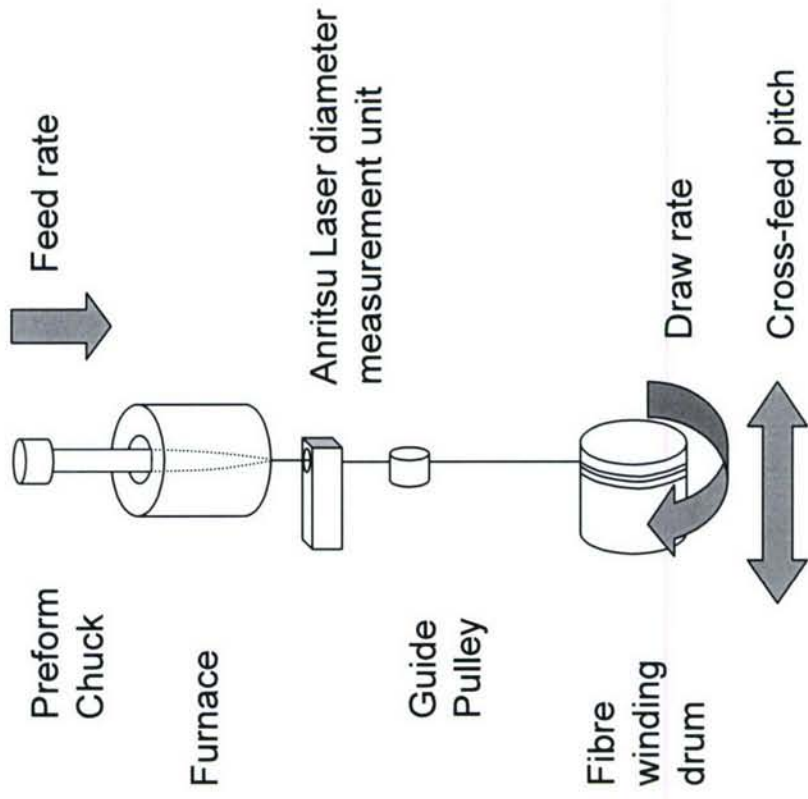

- Infiltration schematic

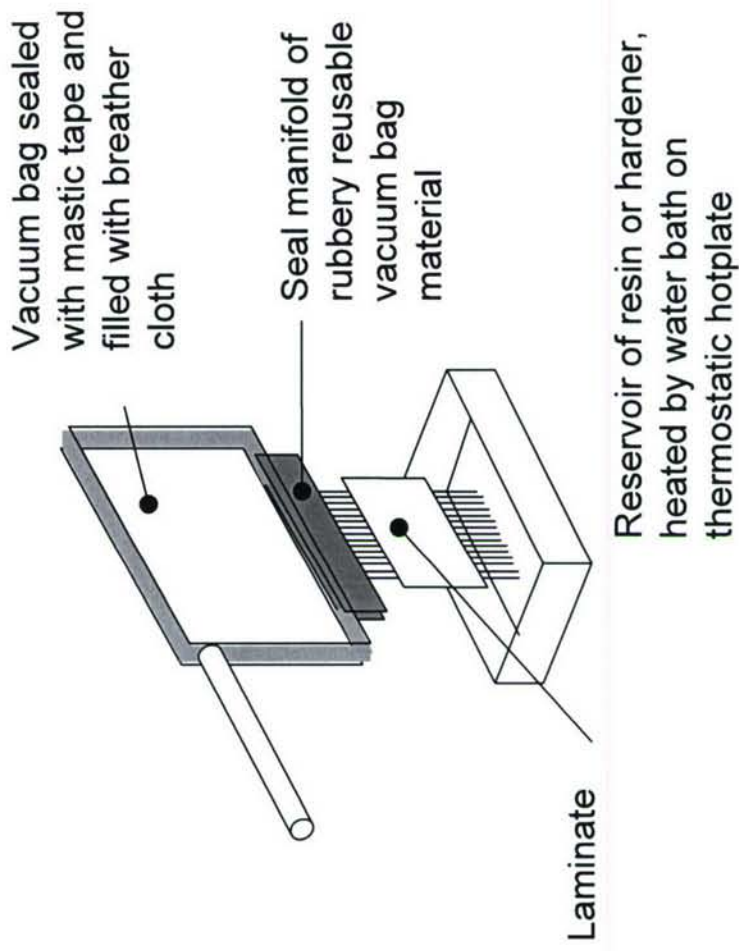

Self-Healing Composite: Consolidation

- 60 μm diameter, 55% hollowness
- Hollow fibre sealing
 - High-temperature, high modulus silicone sealant
- Hollow fibre orientation within laminate
- Two part: resin and hardener aligned in the same ply

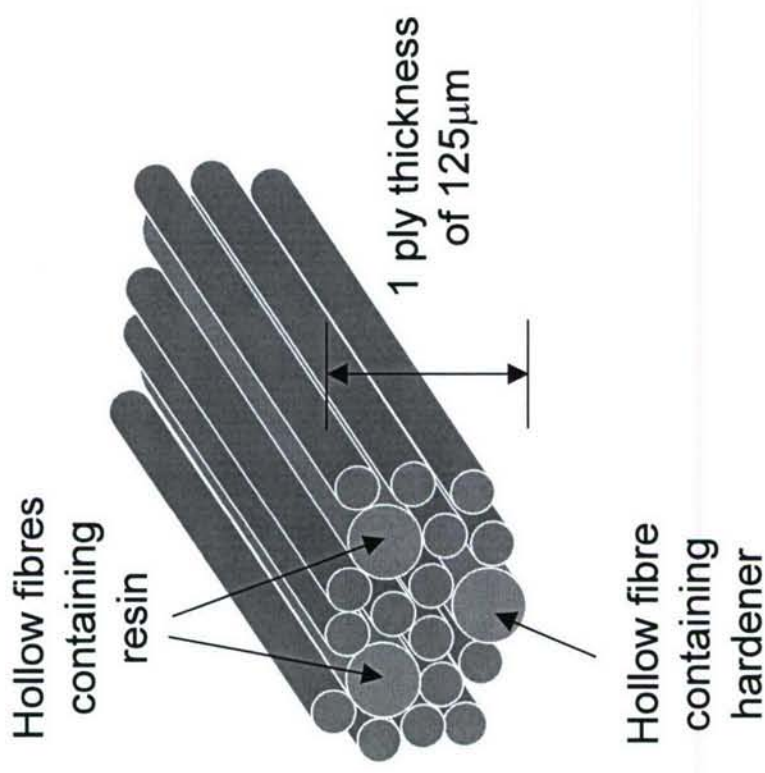

Self-Healing Composite: Healing Infusion

7

16 ply $[0^\circ/45^\circ/90^\circ/-45^\circ]_{2s}$ E-glass/913 epoxy with self-healing plies at $\pm 45^\circ/90^\circ$ interfaces

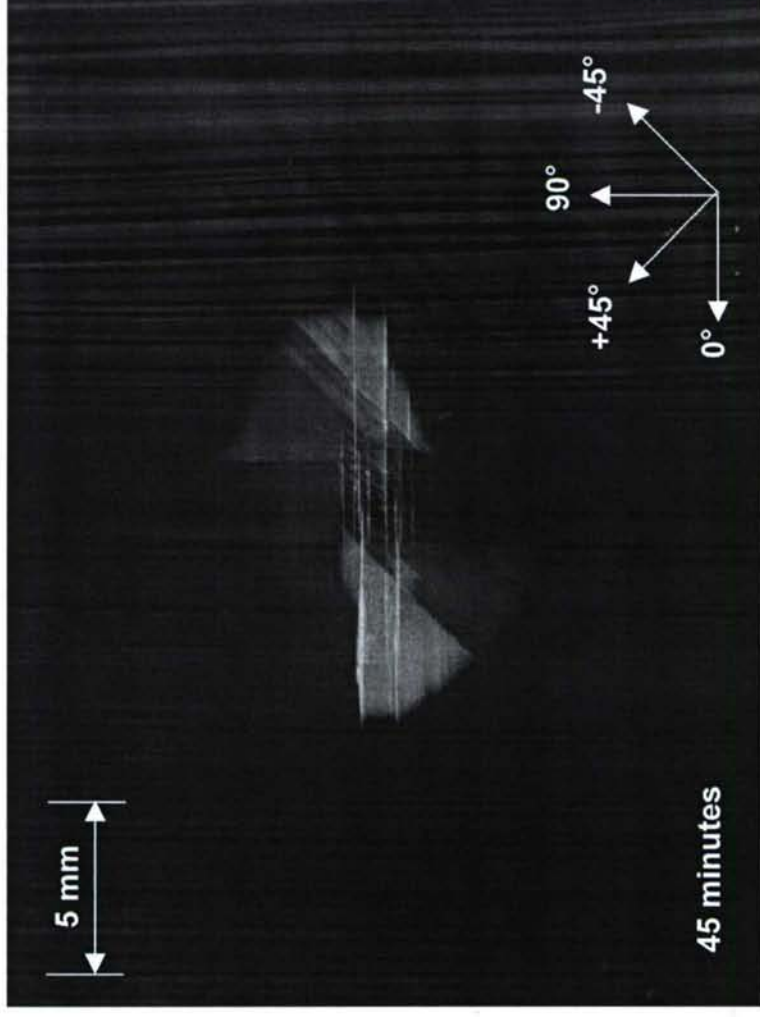

Time lapse photography showing Cytec 823 epoxy resin and hardener with UV dye infiltrating the damage site at 90°C

Self Healing CFRP

Dr. Richard Trask

R.S.Trask@bristol.ac.uk

Gareth Williams

G.J.Williams@bristol.ac.uk

Self-Healing CFRP

9

- The aim is to develop a self-healing process suitable for Carbon Fibre Reinforced Plastics.
 - Optimise hollow fibre spacing to match threat
 - Mechanical property assessment (flexure & CAI)
 - C-scanning
 - Fracture toughness (Mode I & II)

Self-Healing CFRP: Drivers

10

- Embedded HGF must not:
 - Degrade mechanical performance of undamaged laminate
 - Reduce Carbon Fibre Volume Fraction of laminate
 - Generate resin rich regions
- Achieved by two variables:
 - Reduction in HGF OD
 - Location of HGF in laminate lay-up
- However, also influence healing potential:
 - Resin volume $\propto r^2$
 - Certain interfaces will experience greater levels of damage and connectivity to delaminations

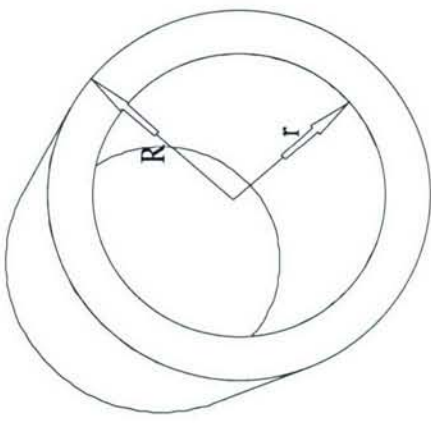

Self-Healing CFRP: Test Methodology

11

- Assessment of the effects of varying HGF spacing on:
 - Flexural 4 point bend strength (undamaged)
 - Impact resistance of laminates (damaged)
 - Ability to heal an impact event (damaged + healed)
- 2 x HGF spacings selected to compare with baseline laminate (measured HGF centre to centre (μm))
 - 70 μm @2 interfaces
 - 200 μm @2 interfaces

Self-Healing CFRP: Laminate Configuration

12

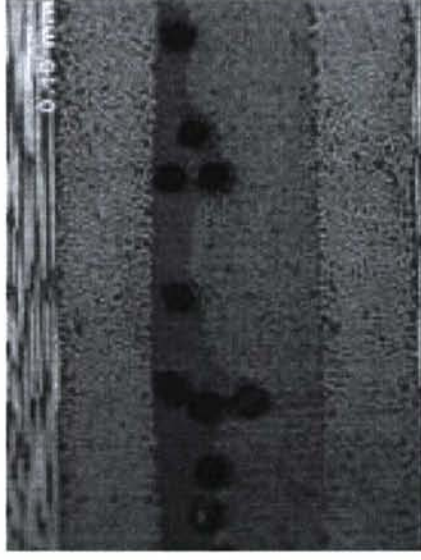
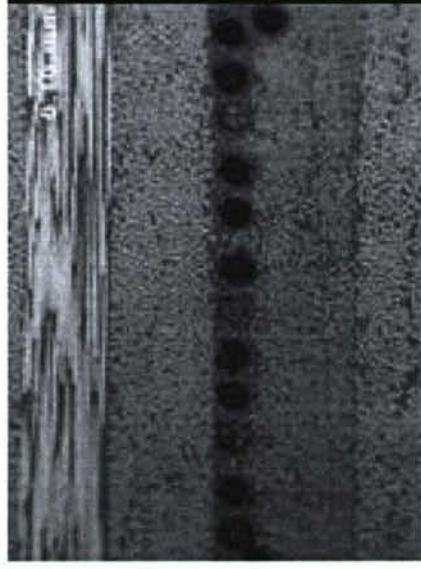
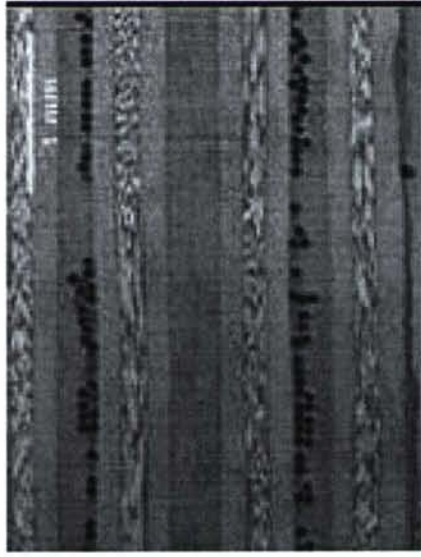

70µm HGF spacing within a 16 ply $[-45^\circ/90^\circ/+45^\circ/0^\circ]_{2s}$ CFRP (T300/914)

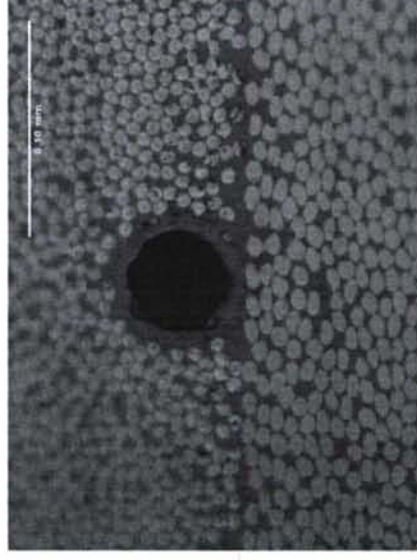
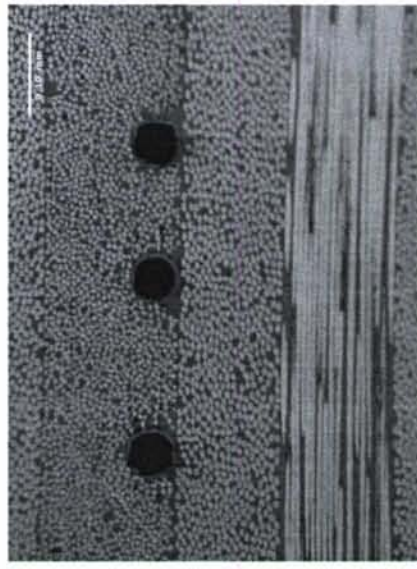
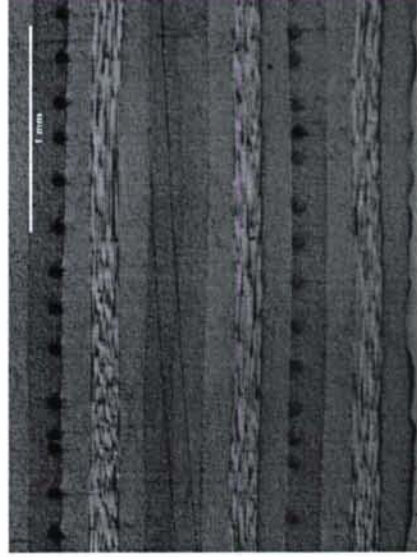

200µm HGF spacing within a 16 ply $[-45^\circ/90^\circ/+45^\circ/0^\circ]_{2s}$ CFRP (T300/914)

Self-Healing CFRP: Strength Recovery @70µm Spacing

13



70µm HGF spacing within a 16 ply [-45°/90°/+45°/0°]_{2s} CFRP (T300/914)

- Impact damage generated by quasi-static indentation (ASTM D6264-98)
- Residual strength assessed by 4-point flexural testing (ASTM D6272-02)

CFRP had a strength recovery of:

- **89%** compared to undamaged baseline laminate
- **97%** compared to undamaged hollow fibre laminate.

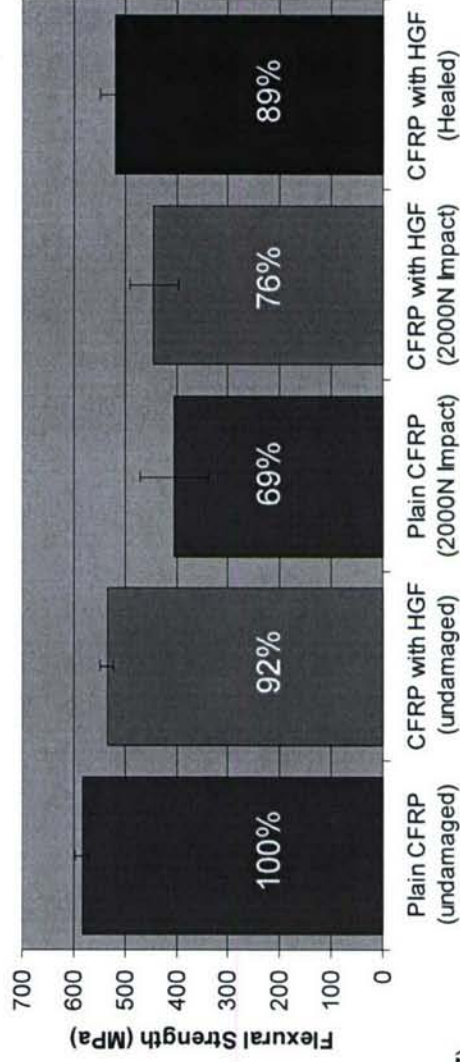

Williams GJ, Trask RS, Bond IP; Composites A. (2007)
doi: 10.1016/j.compositesa.2007.01.013

Self-Healing CFRP: Strength Recovery @200µm Spacing

14

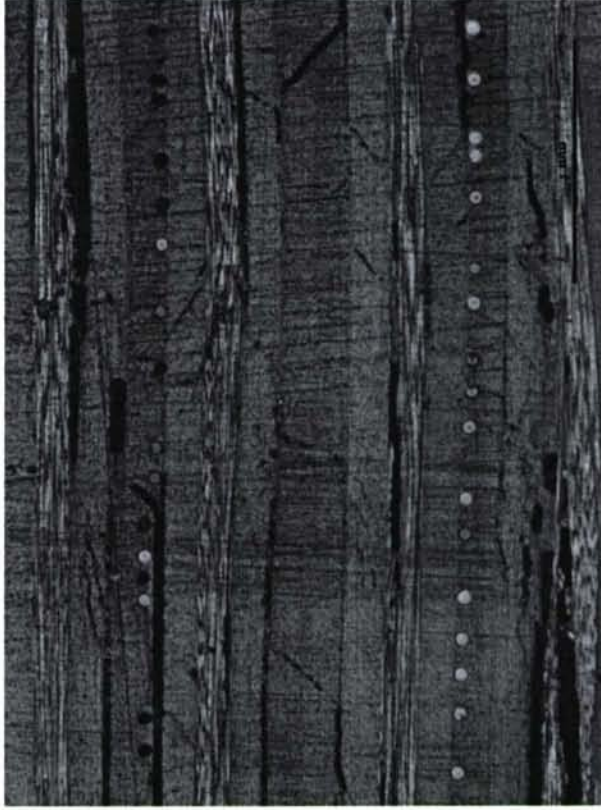

200µm HGF spacing within a 16 ply
[-45°/90°/+45°/0°]_{2s} CFRP (T300/914)

- Impact damage generated by quasi-static indentation (ASTM D6264-98)
- Residual strength assessed by 4-point flexural testing (ASTM D6272-02)

- CFRP had a strength recovery of:
- **80%** compared to undamaged baseline laminate
 - **82%** compared to undamaged hollow fibre laminate.

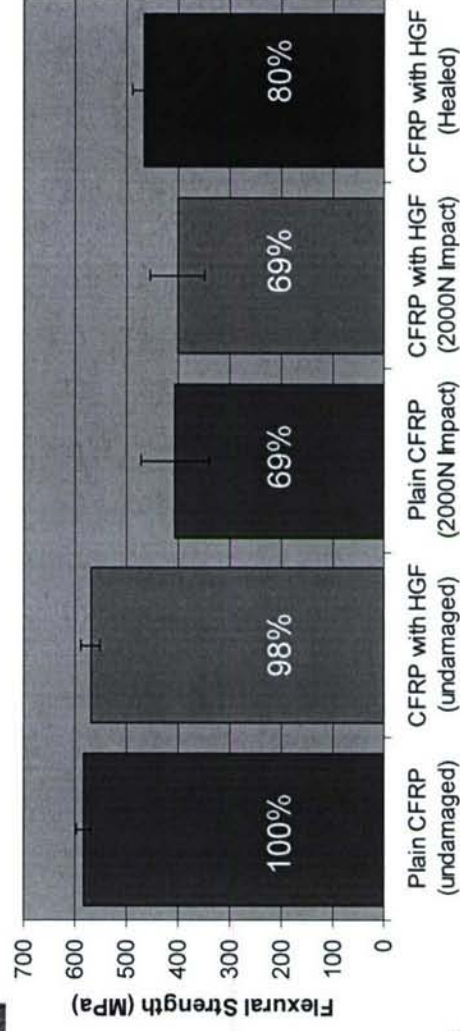

Williams GJ, Trask RS, Bond IP; *Composites A.* (2007)
doi: 10.1016/j.compositesa.2007.01.013

Self-Healing Composite: Healing Infusion

No UV →
illumination

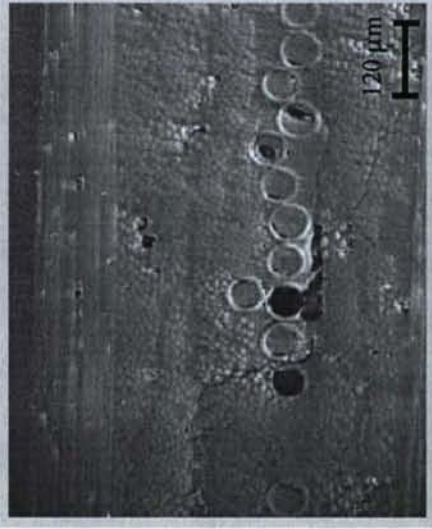
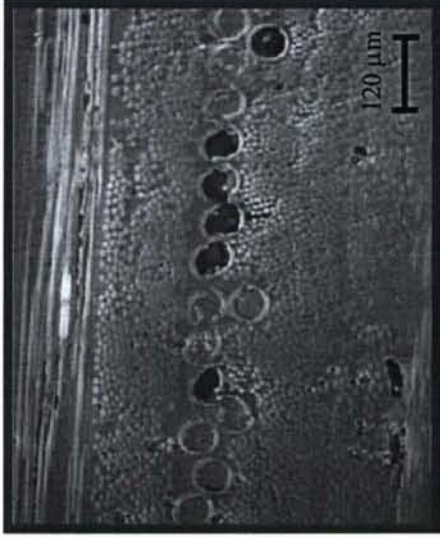

0°

+45°

90° & Self Heal

-45°

UV →
illumination

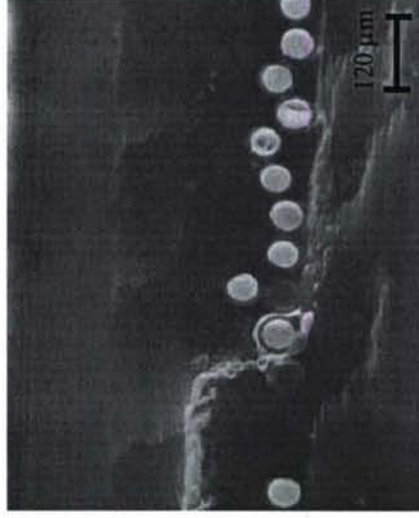

16 ply [0°/45°/90°/-45°]_{2s} E-glass/913 epoxy with self-healing plies.
60μm OD hollow fibres containing Cycom 823 epoxy resin + UV dye

Self-Healing CFRP: Fractography

- 6J impact on QI 16ply T300/914 CFRP with embedded HGF

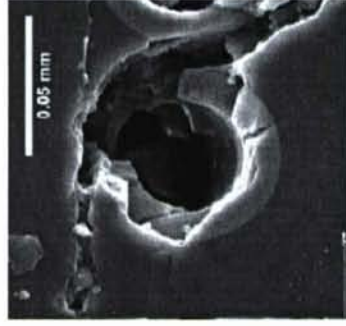
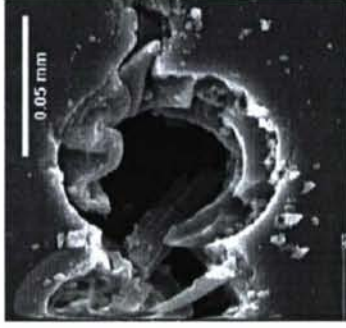

- DCB fracture surface of 45/0 interface 32ply IM7/8552 CFRP

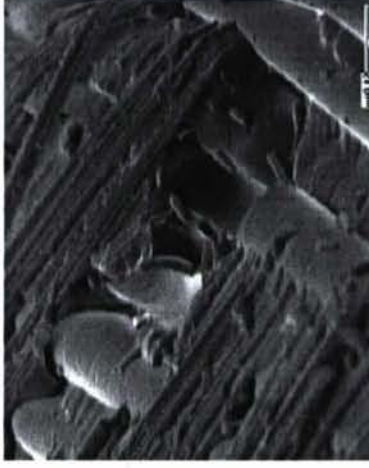

Self-Healing CFRP: CAI (Ongoing)

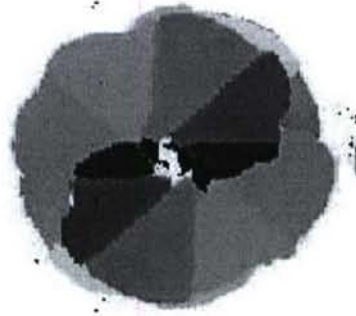
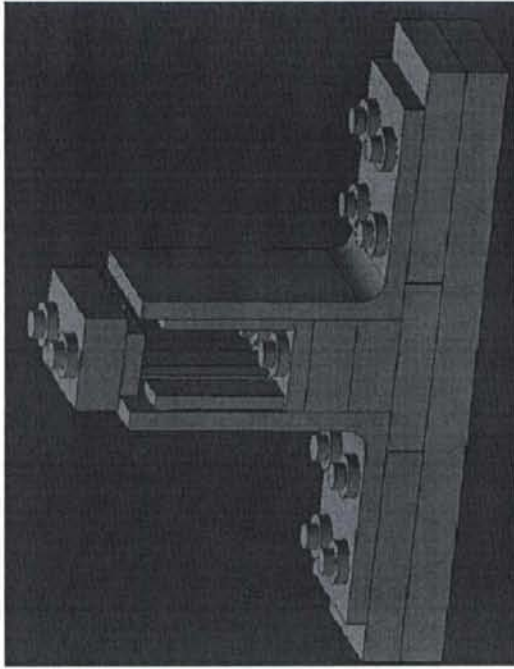

6J Impact

Boeing Standard CAI
(ASTM D137/D 7137M-05) modified
for coupon size 89x55x2.5mm

— Plain — 70micron — 200micron

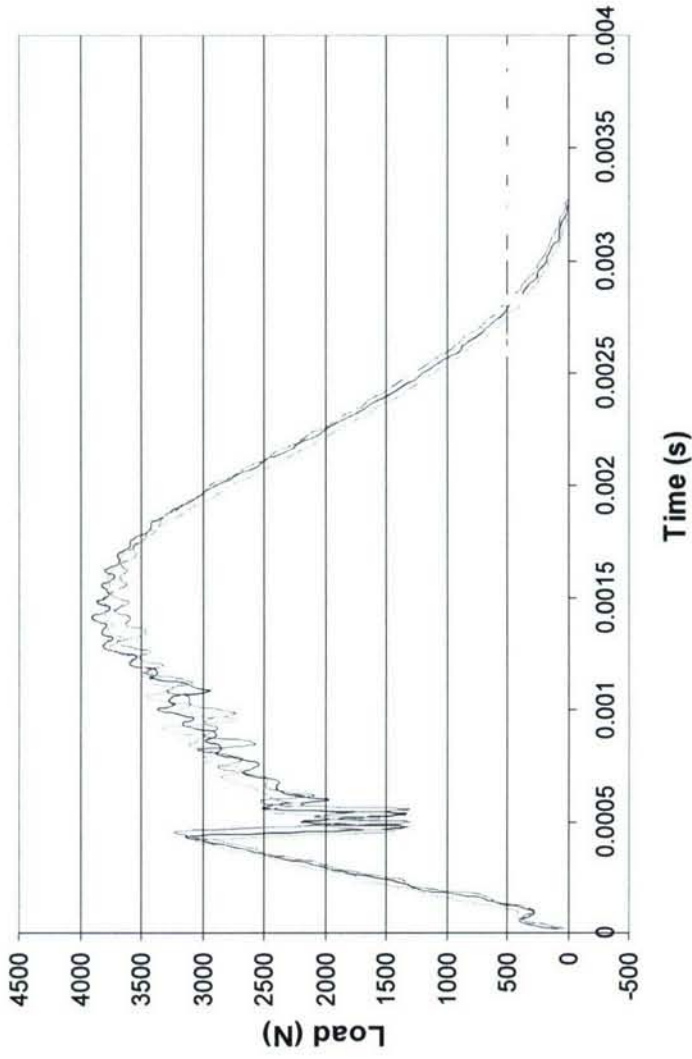

Self-Healing CFRP: CAI (Ongoing)

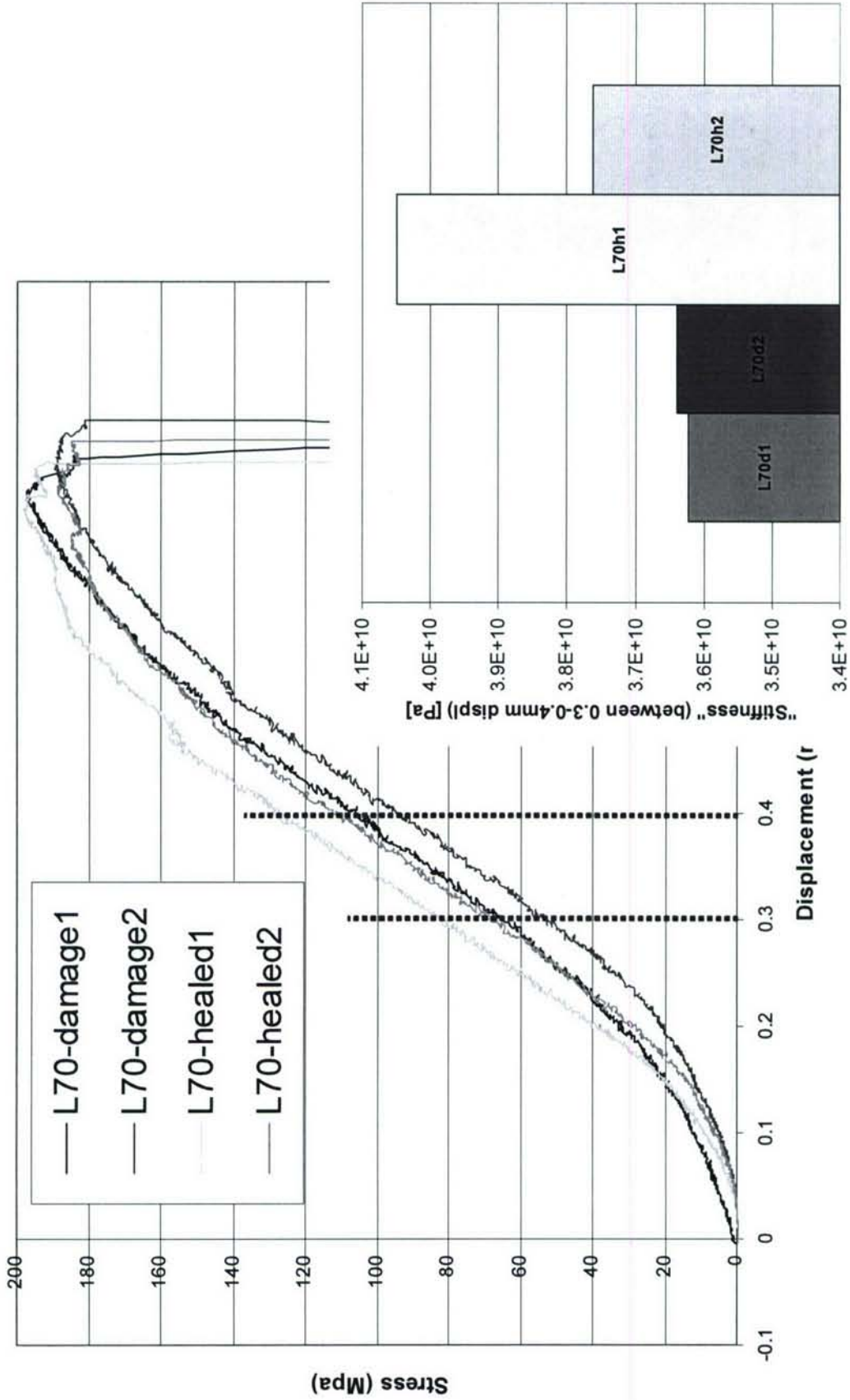

Vascular Networks - Sandwich Structures

Dr. Richard Trask

R.S.Trask@bristol.ac.uk

Hugo Williams

Hugo.Williams@bristol.ac.uk

Opportunities & Motivation

- Sandwich structures extensively used in secondary aerospace and primary marine structures.
- Several drivers for widening their use.
- Up to 50% loss in residual compressive strength caused by impact damage in sandwich structures.
- Significant skin-core debonding can exist with very little visual indication of damage.
- Current repair techniques involve excising damaged skin and core and bonding in replacements: effective but time consuming.

Aim: To introduce a self-healing ability into a typical sandwich structure via a vascular network.

Vascular Self-Healing: Concept

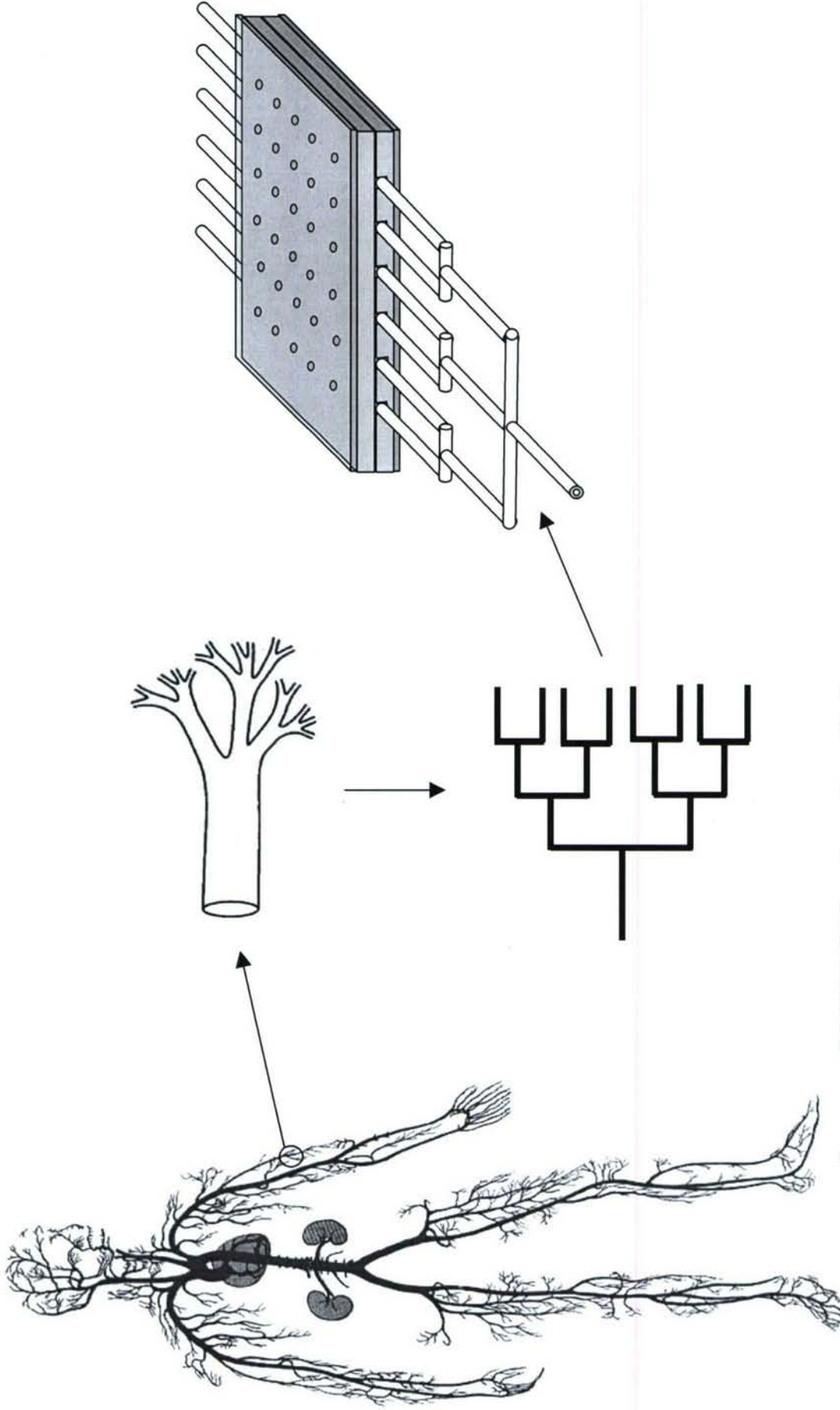

Source: www.accesscellence.org/AE/AEC/CC/heart_anatomy.html

Vascular Self-Healing: Composite Sandwich Structure²²

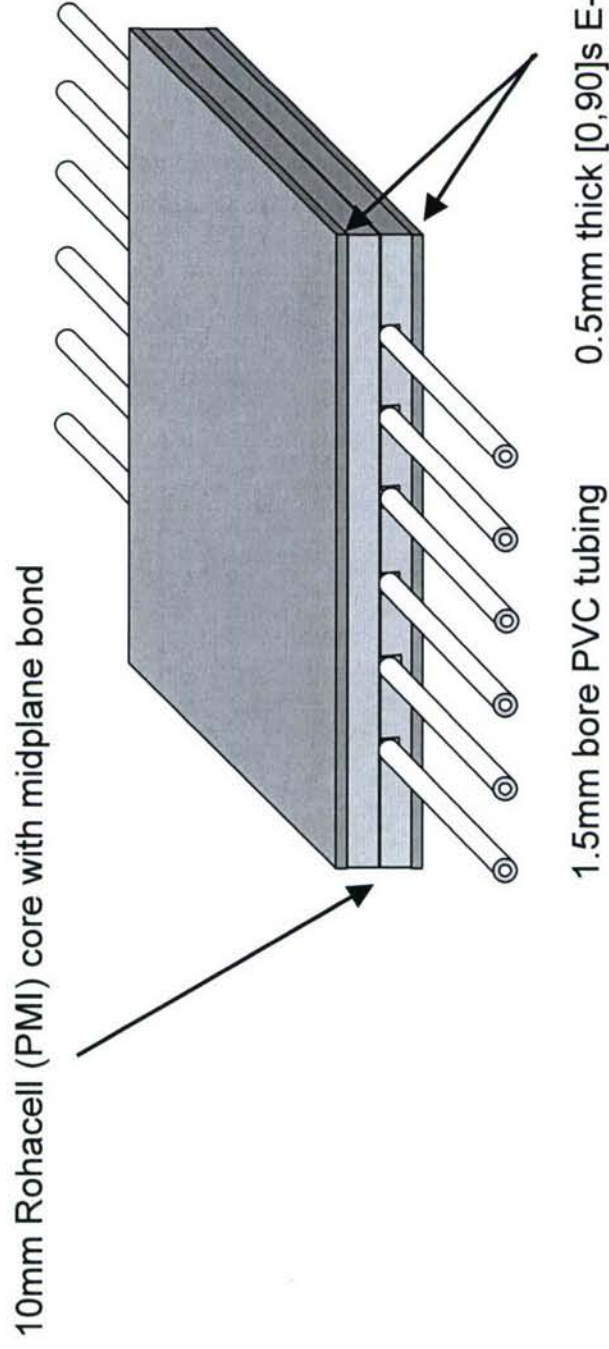

Vascular Self-Healing: Composite Sandwich Structure ²³

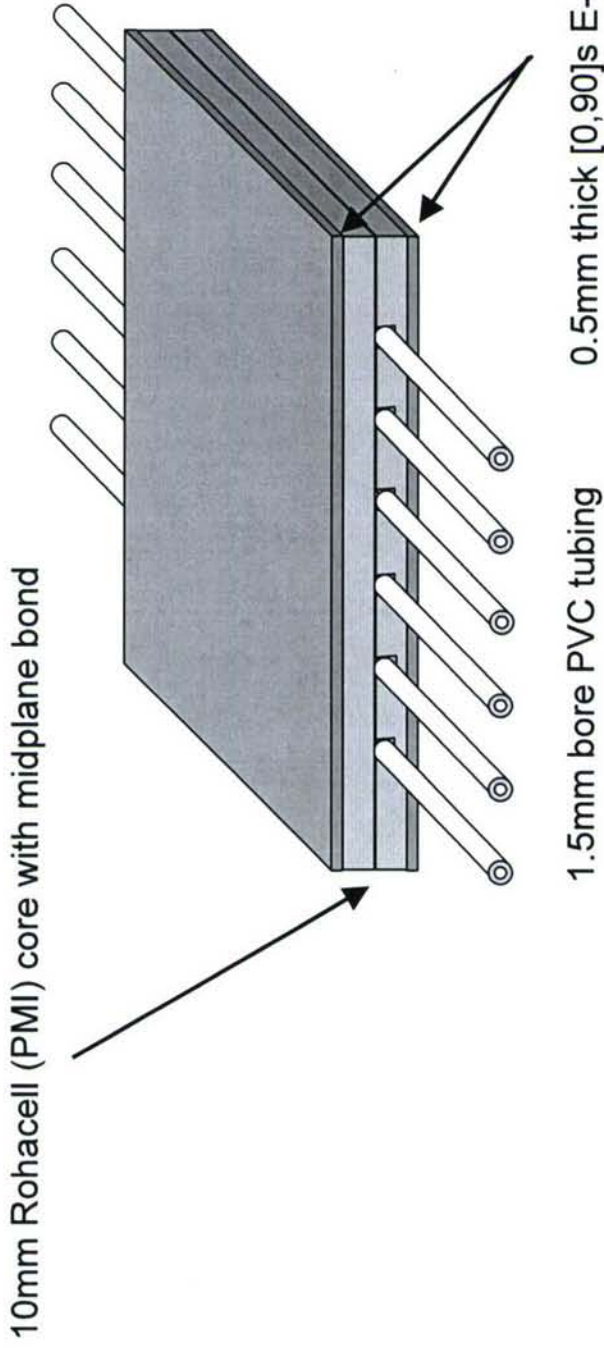

Vascular Self-Healing: Architecture

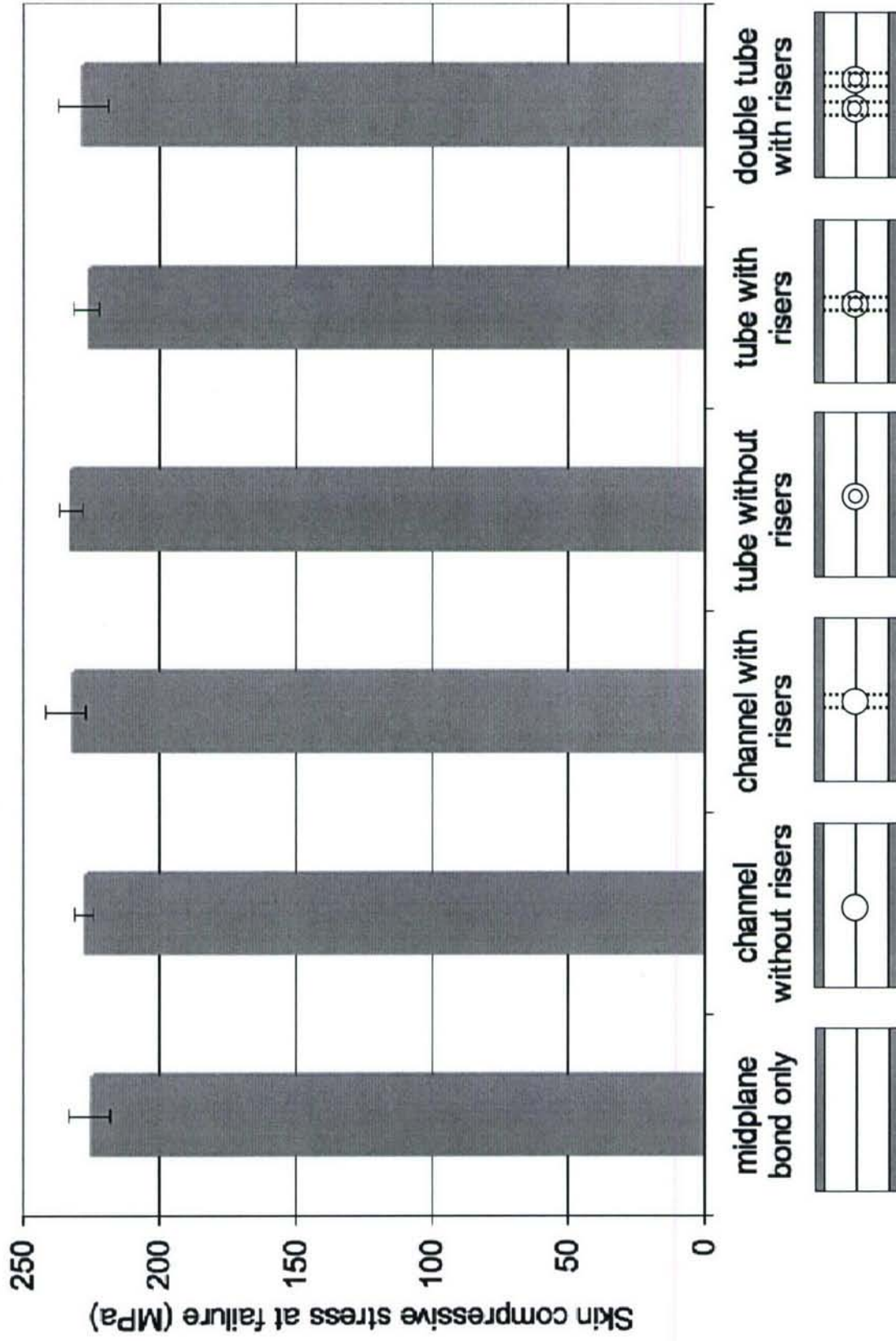

Vascular Self-Healing: Quantitative Testing

25

- Beam specimens filled with pre-mixed, 2-part epoxy resin (SPSystems Ampreg 20) which is pressurised to 4700Pa under static head.

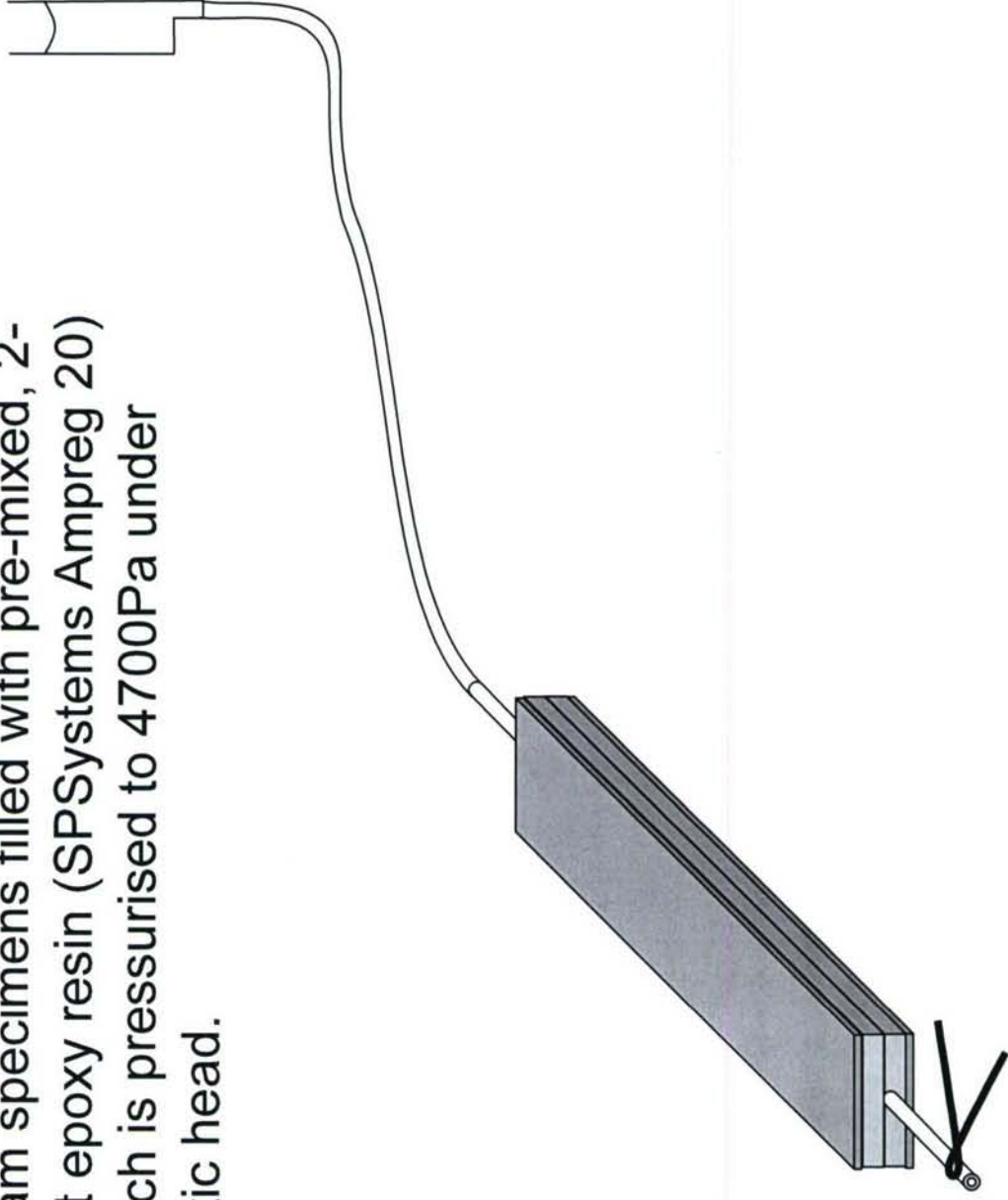

Vascular Self-Healing: Quantitative Testing

26

- Beam specimens filled with pre-mixed, 2-part epoxy resin (SPSystems Ampreg 20) which is pressurised to 4700Pa under static head.

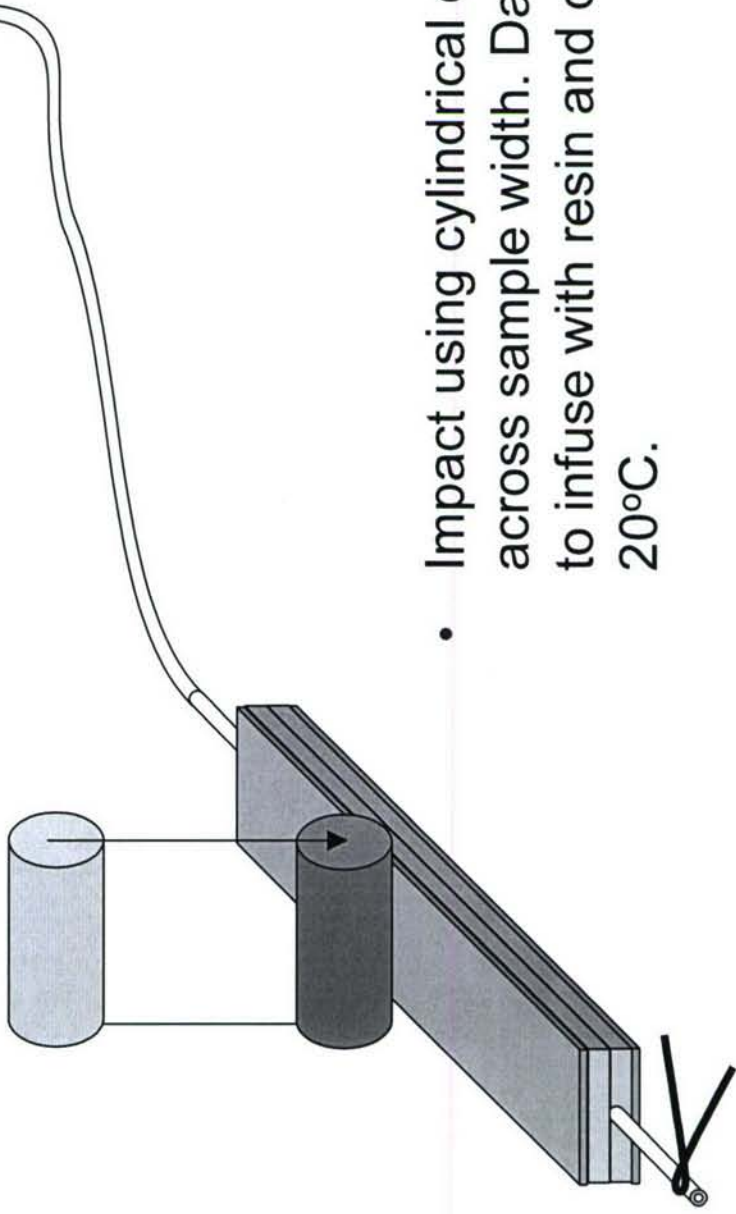

- Impact using cylindrical drop weight across sample width. Damage allowed to infuse with resin and cure for 36hrs @ 20°C.

Vascular Self-Healing: Impact Testing

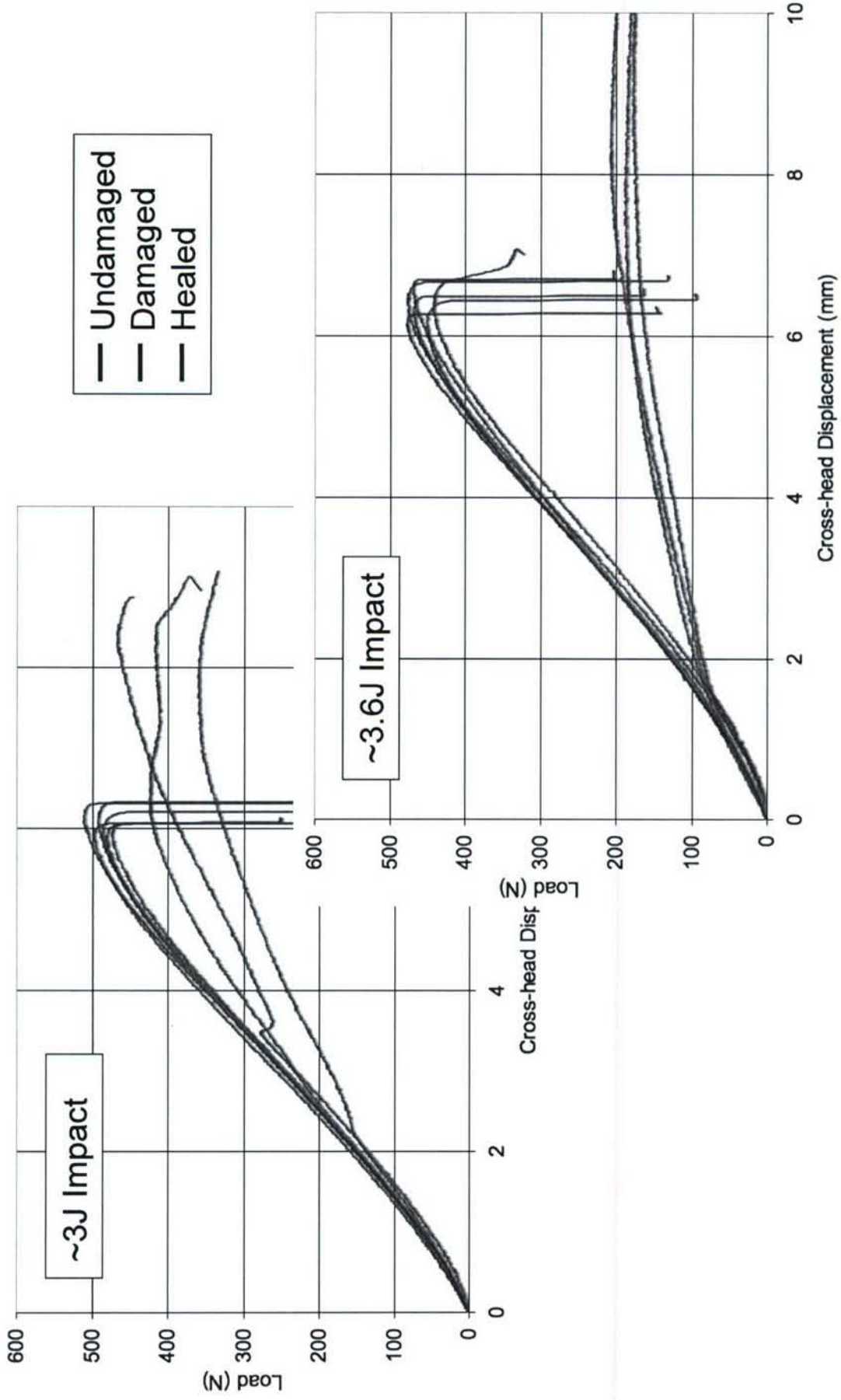

Vascular Self-Healing: Flexural Testing

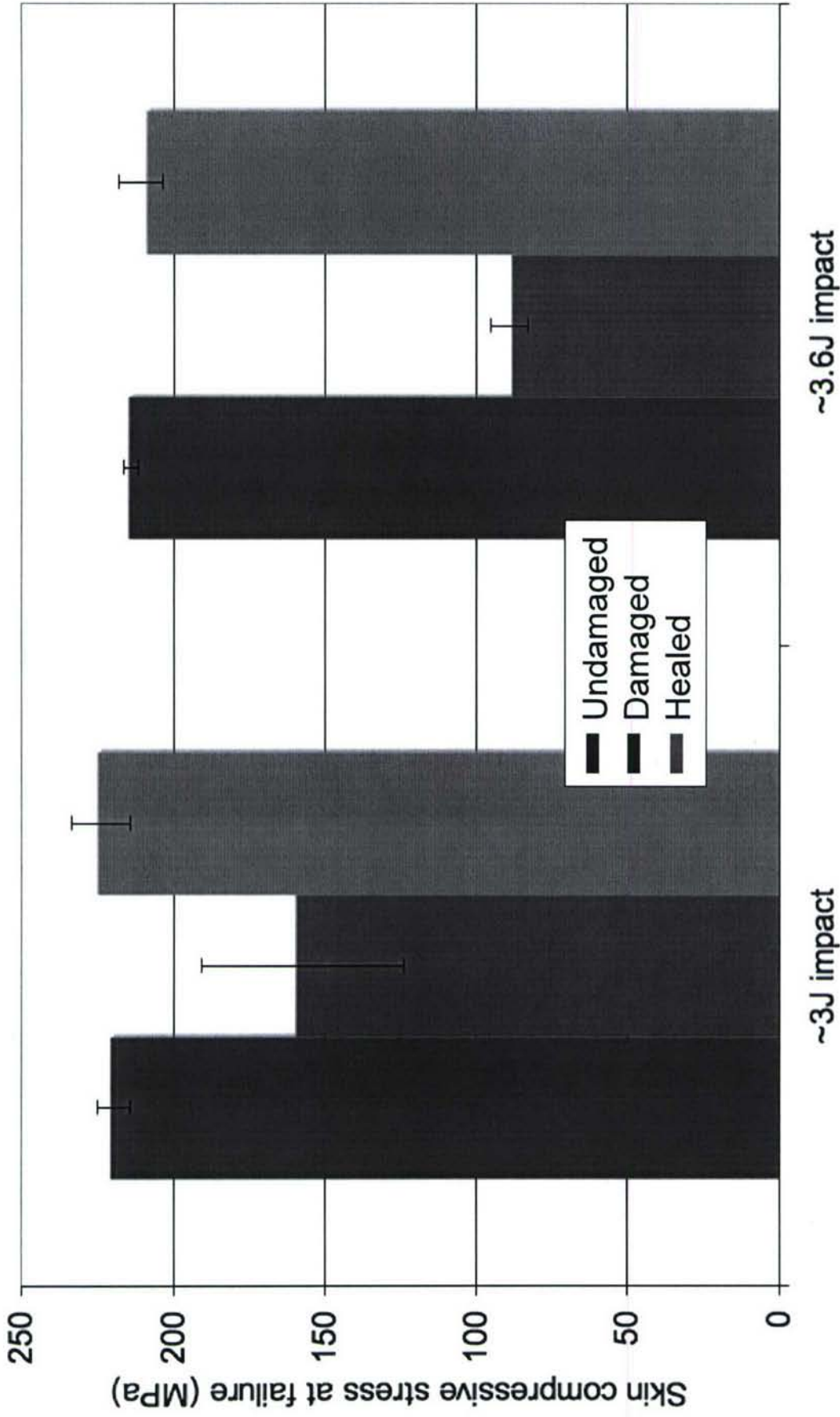

Vascular Self-Healing: Healing Initiation

29



450N quasi-static point indentation

Vascular Self-Healing: Failure Modes in 4PB

ASTM C393

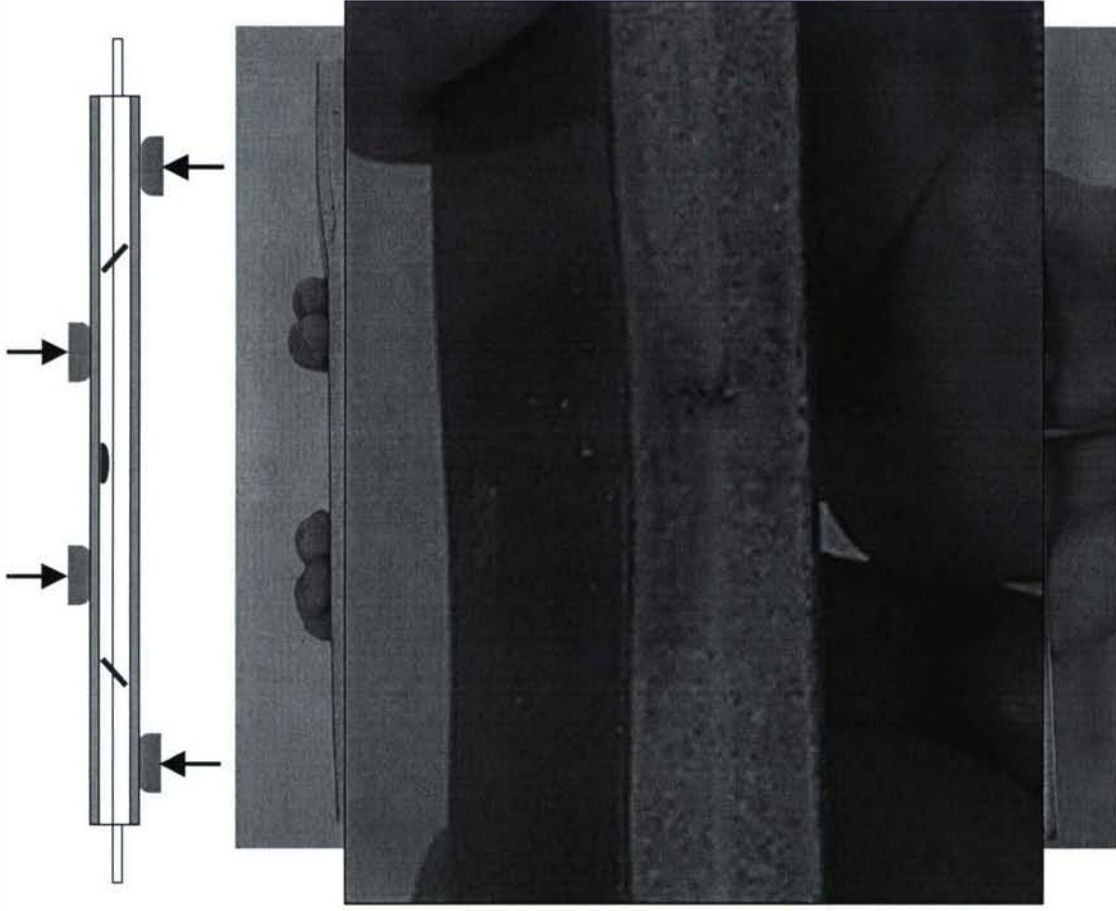

• Undamaged

• Damaged

• Healed

Core Shear

Skin buckling

Core Shear

Vascular Networks - Laminates

Dr. Richard Trask

R.S.Trask@bristol.ac.uk

Chia-Yen Huang

Chiayen.huang@bristol.ac.uk

Gorka Conlledo

gc6153@bristol.ac.uk

Jessica Bland

jb2274@bristol.ac.uk

Vascular Networks: Laminates

- Aim: To incorporate a pressurised vascular network into a structural composite to provide autonomous self-healing (space appln.).
- Tackle **penetrative** damage, seal fissure and restore structural integrity.

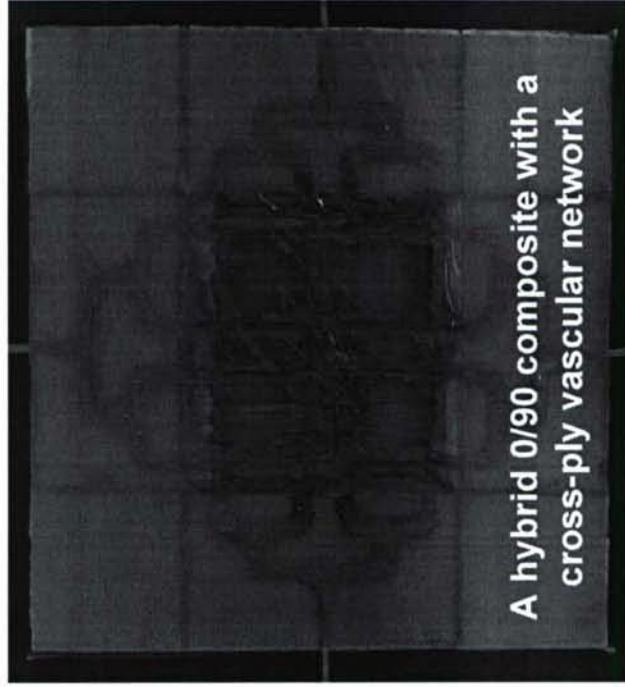

- Hybrid Kevlar (*scaffold former?*) & E-glass/epoxy laminates with UD and cross-ply (0/90) vascular network patterns
- Preliminary stage: large scale network (1mm in diameter) of silicone tubing, PP connectors and glass capillaries

Vascular Networks: Laminates

- Can we apply POISEUILLE'S law to vascular networks?

$$Q = \frac{\pi(d_i^4)\Delta P}{128L\mu}$$

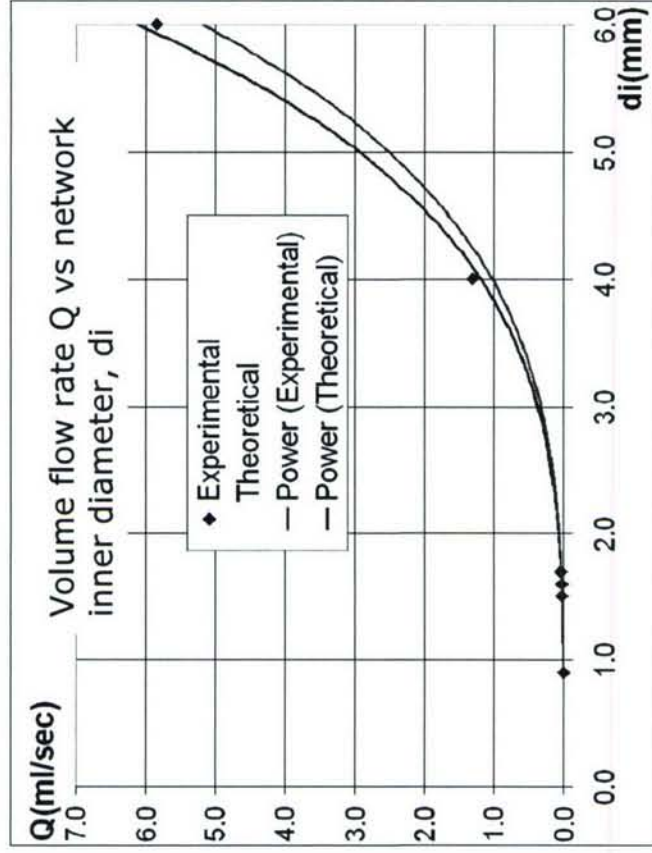
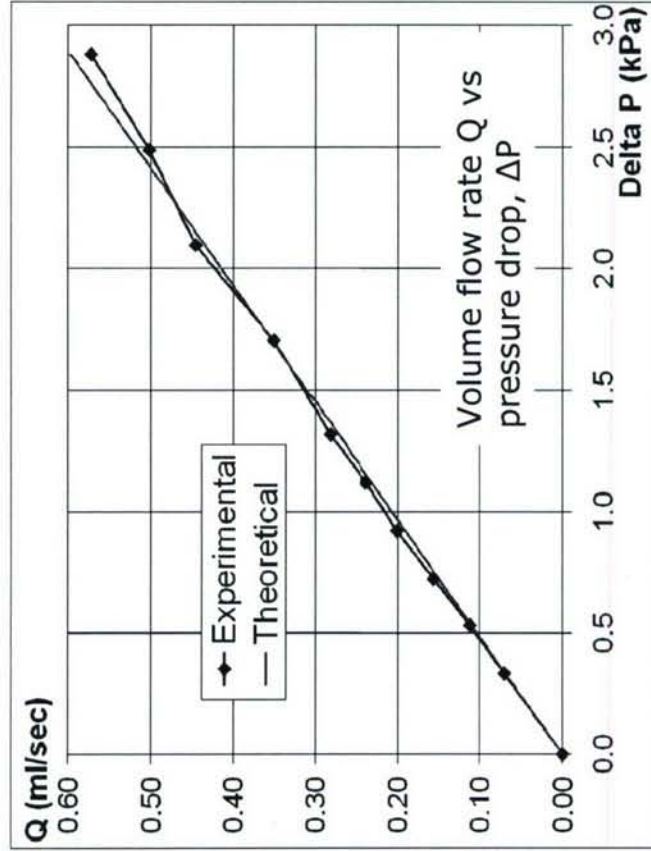

Vascular Networks: Laminates

- Effect of branching on volume flow rate, Q ?

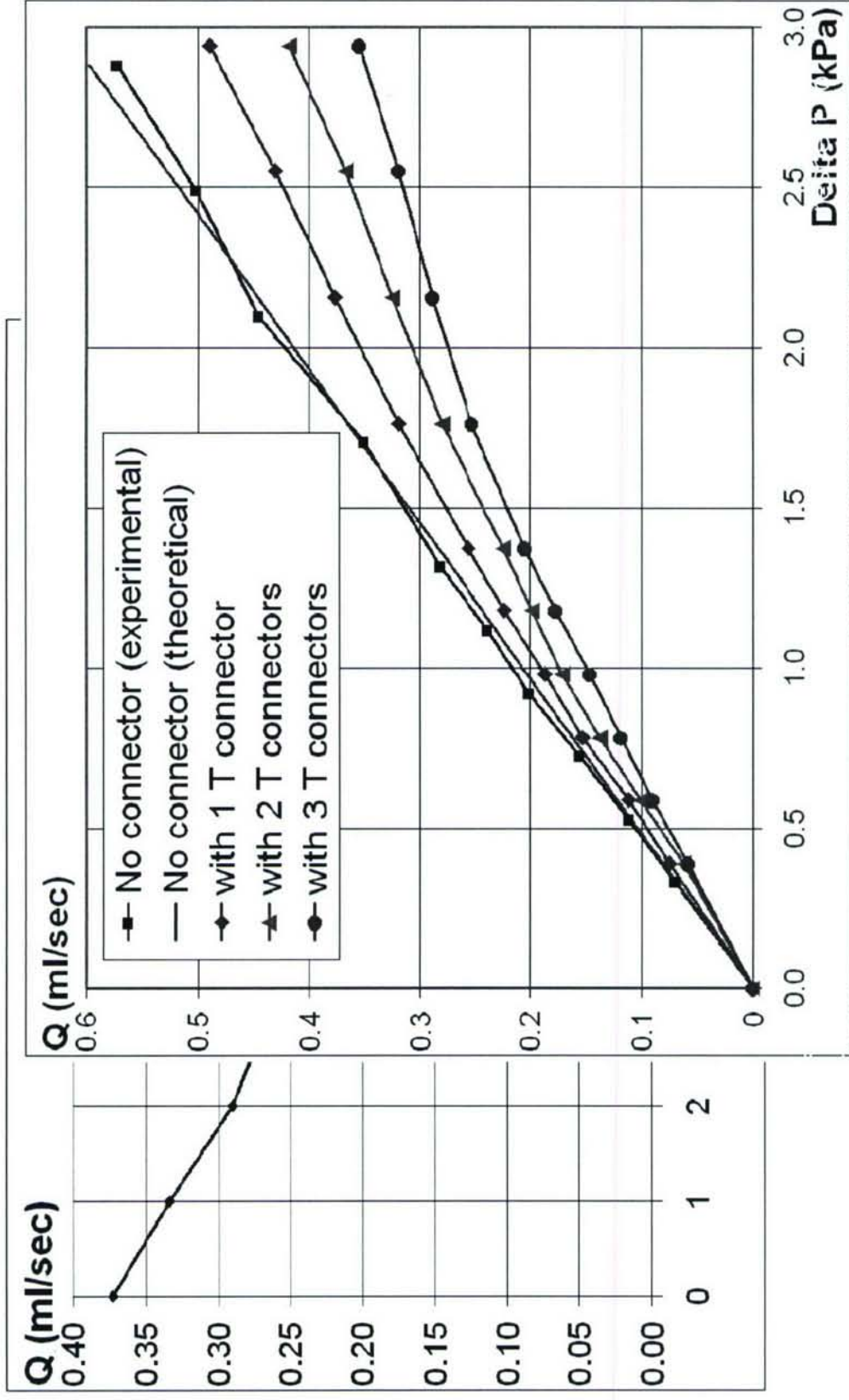

Vascular Networks: Laminates

- Aim: To devise a methodology to create a vascular network inside a laminate using a 'lost wax' process
- Network precursor 'lost wax' materials
 - Solder wire – *melt*
 - Nylon monofilament - *melt*
 - P84 polyimide fibres (Tg 315°C) – *conc. H₂SO₄*

- Network Design

- Unidirectional



- Orthogonal



Vascular Networks: Laminates

- Characterisation

- Mode I DCB (250 x 25 mm)
- Lay-up [$0_4 / 90_4 / 0_4 / 90_2$]_s
- Network in resin film layer on C/L between [90₂/90₂] plies

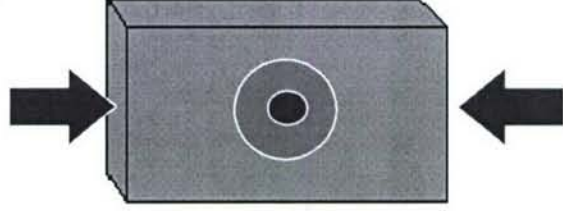

- CAI (89 x 55 mm)
- Lay-up [$0 / 45 / 90 / -45 / 0_2 / 45 / 90 / -45$]_s
- Network in resin film layer between [0/0] plies

Optimising Healing Resins

Vitalba Imperiale

V.Imperiale@bristol.ac.uk

Objectives

- Investigate different healing systems formulated by varying chemical/physical properties of:
 - Epoxy Monomers (Glycidyl Ether, Glycidyl amine)
 - Curing agent (Aliphatic, Cycloaliphatic, Aromatic amine)
 - Accelerator/co-curing agent (to allow sluggish cycloaliphatic compounds to react at room temperature)
- Characterise performance of these formulations in terms of:
 - Level of miscibility between monomers and hardeners
 - Stoichiometry vs. time needed to cure at RT
 - Stoichiometry vs. Adhesion/Healing properties (in substrate)
- Characterise selected system(s) on a composite scale according to previous hollow fibre in CFRP techniques
 - Flexure?
 - CAI?
- Investigate the possibility of encapsulating the curing agent.
 - collaboration with Bristol Colloid Centre & UIUC.

Epoxy Resin Selection

	glycidyl ether of para-aminophenol	Tetraglycidyl-ethylenebisbenzamine	Bisphenol F Epoxy resin	Bisphenol A Epoxy resin
characteristics refer to	Multifunctional epoxy resin Grade: Distilled Trifunctional low viscosity epoxy resin based on para aminophenol. Performance upgrader for bis A resins. Used for rapid cure laminates, adhesives, having exceptional high heat deflection temperature		Unmodified bis F epoxy resin, very low viscosity. Used in filament winding, casting, pultrusion, RTM and adhesives	High purity BIS A Epoxy low viscosity low content
chemical structure				
epoxide equivalent weight g/eq	550-850	3000-6000* @ 50C	156-167	(g/eq) 171 - 175
viscosity range cps@25			1200-1800	4000-6000

- Epoxy resins can be divided into 6 classes of resins, most suitable for self-healing are: Glycidyl Ether (obtained from the reaction of epichlorhydrin and hydroxyl compounds)
- Glycidyl amine (Obtained by glycidylation of amines with epichlorhydrin)

- Parameters:
 - Molecular weight
 - Molecular weight distribution
 - Crystallinity
 - Epoxy equivalent weight

Polyamine as curatives 1: Aliphatic primary amine

name	name	RT cure	formula	
Ethylenediamine	EDA	yes	$\text{H}_2\text{N}-\text{CH}_2-\text{CH}_2-\text{NH}_2$	Mobile fuming liquid unpleasant to handle addeducted with resins or in solution coating application
Diethylenetriamine	DETA or DTA	yes	$\text{H}_2\text{N}-\text{CH}_2-\text{CH}_2-\text{NH}-\text{CH}_2-\text{CH}_2-\text{NH}_2$	Mobile fuming liquid, unpleasant to handle; tooling and laminating, often blended with polyamides for adhesive applications. Able to cure under high humidity conditions causes surface bloom. It can be reacted with ethyleneoxide to improve handling
Tri ethylen tetr amine	TETA	yes	$\begin{array}{c} \text{CH}_2-\text{CH}_2-\text{NH}_2 \\ \\ \text{N} \\ \\ \text{CH}_2-\text{CH}_2-\text{NH}_2 \\ \\ \text{CH}_2-\text{CH}_2-\text{NH}_2 \end{array}$	similar properties to those obtained with DTA. HDT of resins can be improved by post curing
Trimethylhexamethylenediamine	TMD	yes		Low viscosity aliphatic branched chain diamine, consisting of a blend of two isomers. It can be used alone or as accelerator for IPD. Coating and flooring applications.
Hydroxyethyldiethylenetriamine	T	yes		casting and adhesives application often with diluted resins
Dipropylenediamine	DPTA	?yes		
tetraethylenepentamine	TEPA	vd tetra	$\begin{array}{c} \text{H}_2\text{NCH}_2\text{CH}_2\text{NHCH}_2\text{CH}_2 \\ \\ \text{H}_2\text{NCH}_2\text{CH}_2\text{NHCH}_2\text{CH}_2 \\ \\ \text{NH} \end{array}$	Liquid Aliphatic polyamine properties as TETA used for coating application from solutions
Diethylaminopropylamine	DEAPA	yes	$\text{H}_3\text{C}-\text{N}(\text{CH}_3)-\text{CH}_2-\text{CH}_2-\text{CH}_2-\text{NH}_2$	Aliphatic amine containing tertiary amine which act as a catalyst at RT. Used at only 4-8 phr rather than the amount expected from calculation based on the two active hydrogens Adhesive applications
Dimethylaminopropylamine	DMAPA	yes	$\text{H}_3\text{C}-\text{N}(\text{CH}_3)_2-\text{CH}_2-\text{CH}_2-\text{CH}_2-\text{NH}_2$	same as DEAPA

Aliphatic primary amine
Mixed with polyamine are able to improve their flexibility being applicable for adhesives applications.

Polyamine as curatives 2: Cycloaliphatic Amine

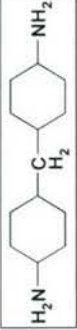
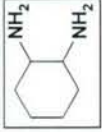
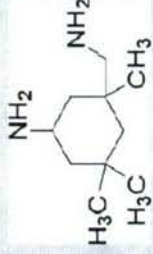
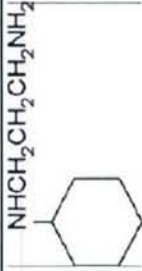
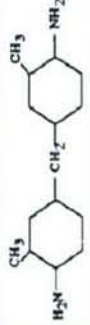
n-aminoethylpiperazine	nAEP	yes partly, post cure required to acquire full props		excellent impact properties when fully cured. Short pot-life, high exotherm. It is not able to fully cure at RT due to the formation of the so-called B-stage. Used in formulated amine curing agents and/or acidic accelerators allow fully curing at RT
	PACM20 cis-cis or cis-trans			Non si trova su sigma-aldrich. Low viscosity liquid. It is suitable for modification as an adduct for ambient temperature applications
1,2-cyclohexanediamine	1,2-DACH			more reactive than PACM20, better suited for use in modified form in ambient cure temperature
Isophoronediamine 3-aminomethyl-3,3-trimethylcyclohexylamine	IPDA	yes with accelerator and diluent		Low viscosity Liquid
Cyclohexylpropylenediamine		yes with accelerator co-curing agent or diluent		Intermediate reactivity between aliphatic and aromatic amines. Typical accelerator: Salicylic acid, phenol, and triphenyl phosphite.
3,3-dimethyl-4,4-diaminodicyclohexylmethane		yes with accelerator co-curing agent or diluent		Casting and laminating application. Typical accelerator: Salicylic acid, phenol, and triphenyl phosphite. Warm! Reaction with carbon dioxide, crystallization at RT

CYCLOALIPHATIC

Accelerator and co-curing agent

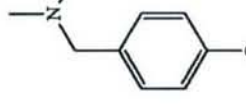
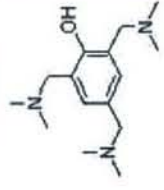
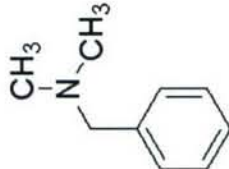
	name	Trade Name	formula	Characteristics
Tertiary Amine	Dimethylaminomethylphenol			Thanks to the Phenolic hydroxyl group contained as an integral part of the molecule these tertiary amines are able to enhance a two step initiation process in the anionic polymerization mechanism. For this reason they are mostly used as catalyst/co-curing agent for polyamine and polyamide based curing agents.
	Tris(dimethylaminomethyl)phenol	DMP 30 K 54		
	BenzylDiMethylAmine	BDMA		This molecules are able to accelerate polysulphides and polymercaptans in RT cure adhesives. Too much catalyst allows achieving faster curing rates but excessive shrinkage and embitterment might be a drawback consequence
	DiazaBicycloUndecene	DBU	