



**A SYSTEMS ENGINEERING PROCESS
FOR AN INTEGRATED STRUCTURAL
HEALTH MONITORING SYSTEM**

THESIS

Matthew S. Bond
DR-02, USAF

James A. Rodriguez
Captain, USAF

Hieu T. Nguyen
1st Lt, USAF

AFIT/GSE/ENY/07-M02

**DEPARTMENT OF THE AIR FORCE
AIR UNIVERSITY**

AIR FORCE INSTITUTE OF TECHNOLOGY

Wright-Patterson Air Force Base, Ohio

APPROVED FOR PUBLIC RELEASE; DISTRIBUTION UNLIMITED

The views expressed in this thesis are those of the authors and do not reflect the official policy or position of the United States Air Force, Department of Defense, or the United States Government.

AFIT/GSE/ENY/07-M02

A SYSTEMS ENGINEERING PROCESS FOR AN
INTEGRATED STRUCTURAL HEALTH
MONITORING SYSTEM

THESIS

Presented to the Faculty

Department of Aeronautics and Astronautics

Graduate School of Engineering and Management

Air Force Institute of Technology

Air University

Air Education and Training Command

in Partial Fulfillment of the Requirements for the
Degree of Master of Science in Systems Engineering

Matthew S. Bond, BS
DR-02, USAF

James A. Rodriguez, BS
Captain, USAF

Hieu T. Nguyen, BS
1st Lt, USAF

March 2007

APPROVED FOR PUBLIC RELEASE; DISTRIBUTION UNLIMITED.

A SYSTEMS ENGINEERING PROCESS FOR AN
INTEGRATED STRUCTURAL HEALTH
MONITORING SYSTEM

Matthew S. Bond, BS
DR-02, USAF

James A. Rodriguez, BS
Captain, USAF

Hieu T. Nguyen, BS
1st Lt, USAF

Approved:



Dr. Som R. Soni, (Chairman)

3/14/07

date



Maj. Jörg D. Walter, PhD, (Member)

14 Mar 07

date



Dr. Dennis D. Strouble, (Member)

16 MAR 07

date

Abstract

The United States Air Force is continually researching ways to reduce costs associated with aircraft maintenance and improve operational safety. This study focuses on creating a systems engineering process to develop an Integrated Structural Health Monitoring System (ISHMS). The overarching process was then applied to design a conceptual ISHMS for a real-world scenario involving the F-15. Sensor selection, integration and testing were explored in detail using frequency response methods to detect structural damage. Testing was accomplished using a simplified structural specimen with Monitoring & Evaluation Technology Integration System (METIS) disk nodes attached at various locations. Two different METIS disk operation modes were utilized; pulse-echo and pitch-catch. Simulated and actual damage were introduced to the specimen allowing comparison between baseline and damaged tests. Comparative analysis validated the capabilities of frequency response sensors to detect damage. This analysis demonstrates that structural health monitoring systems using frequency response methods may be promising in the aerospace sector.

Acknowledgments

First, we would like to thank our advisors, Dr. Soni and Maj. Walter for their support and assistance during this thesis. Their encouragement and words of advice were truly appreciated. We would like to thank our families who have made sacrifices when we have had to work extra hours. Additional thanks goes to the following individuals and organizations for their assistance: Capt. Crider and his advisor, Maj Swenson for their initial knowledge in the METIS sensors as well as Capt Crider's expertise in MatLab to help us plot the data, Mr. Dave Currie at the F-15 depot and Mr. Jeff McFarland from Boeing for their help in focusing the problem and defining initial requirements, and AFRL/ML and AFRL/VA who are also working on structural health monitoring systems.



Figure 1: Thesis Group Photo in Front of F-15 Bulkhead

Table of Contents

| | Page |
|---|------|
| Abstract..... | iv |
| Acknowledgments..... | v |
| Table of Contents..... | vi |
| List of Figures..... | viii |
| List of Abbreviations | x |
| I. Introduction | 1 |
| 1.1 Background..... | 1 |
| 1.2 Proposal | 2 |
| 1.3 Problem and Purpose Statement..... | 2 |
| 1.4 Problem Focus | 3 |
| II. Structural Health Background..... | 6 |
| 2.1 Structural Health Background | 6 |
| 2.2 Current Methods..... | 7 |
| III. System Architectures | 8 |
| 3.1 ISHMS Architectures | 8 |
| 3.1.1 Six Step Architecture Process | 9 |
| 3.1.2 All-Views Architectures..... | 10 |
| 3.1.3 Operational Architectures | 10 |
| 3.1.3.1 OV-1 | 10 |
| 3.1.3.2 OV-5 | 11 |
| 3.2 Architecture Instantiation..... | 33 |
| 3.2.1 Requirements Definition | 33 |
| 3.2.2 System Design..... | 35 |
| 3.2.3 System Installation..... | 37 |
| 3.2.4 System Operation | 38 |

| | Page |
|---|------|
| IV. Sensor Integration..... | 41 |
| 4.1 Introduction | 41 |
| 4.2 Damage Detection using Lamb Wave Propagation..... | 42 |
| 4.3 METIS Sensor Package | 44 |
| 4.4 Test Methodology..... | 45 |
| 4.5 Test Results: First Generation METIS Sensor | 52 |
| 4.6 Test Results: Second Generation METIS Sensor..... | 60 |
| 4.7 Conclusions | 67 |
| V. Recommendations for Further Research and Conclusion..... | 70 |
| 5.1 Suggestions For Further Research With METI Sensor | 70 |
| 5.2 Suggestions For Further Research With Software | 71 |
| 5.3 Additional Suggestions For Further Research..... | 71 |
| 5.4 Conclusion..... | 73 |
| Appendix A. Integrated Data Dictionary (AV-2)..... | 74 |
| Appendix B. First Generation Sensor Test Plots | 82 |
| Appendix C. Second Generation Sensor Test Plots..... | 133 |
| Bibliography | 222 |
| Vita..... | 227 |

List of Figures

| Figure | Page |
|--|------|
| 1. Thesis Group Photo in Front of F-15 Bulkhead | v |
| 1.1. Pictures of F-15 Bulkhead With Crack Highlighted For Detail | 5 |
| 3.1. Generic Six-Step Architecture Process..... | 8 |
| 3.2. AV-1 Architecture | 10 |
| 3.3. OV-1 Architecture | 11 |
| 3.4. Context Diagram..... | 14 |
| 3.5. A-0 Architecture – Decomposition of Monitor Structural Health..... | 15 |
| 3.6. A-1 Architecture – Decomposition of Determine ISHMS Requirements | 16 |
| 3.7. A-11 Architecture – Decomposition of Determine Monitoring Requirements | 18 |
| 3.8. A-12 Architecture - Decomposition of Determine Data Requirements | 19 |
| 3.9. A-13 Architecture – Decomposition of Determine Operational Requirements ... | 20 |
| 3.10. A-14 Architecture – Decomposition of Determine Maintenance Requirements.. | 22 |
| 3.11. A-2 Architecture – Decomposition of Design ISHMS..... | 23 |
| 3.12. A-3 Architecture – Decomposition of Install ISHMS | 25 |
| 3.13. A-4 Architecture – Decomposition of Operate ISHMS..... | 26 |
| 3.14. A-41 Architecture – Decomposition of Collect/Store Data..... | 27 |
| 3.15. A-42 Architecture – Decomposition of Process Data..... | 29 |
| 3.16. A-43 Architecture – Decomposition of Analyze Data..... | 30 |
| 3.17. A-44 Architecture – Decomposition of Utilize Results..... | 32 |
| 3.18. Picture showing the laboratory setup of the test plate | 37 |

| Figure | Page |
|---|------|
| 3.19. Healthy and Damaged Plot on same axes | 39 |
| 3.20. Difference between Healthy and Damaged Plots | 39 |
| 4.1. F-15 Bulkhead Section..... | 46 |
| 4.2. General setup of Test Plate | 47 |
| 4.3. Initial Pulse-Echo Test Matrix | 48 |
| 4.4. Blocks used for Simulated Damage Testing..... | 50 |
| 4.5. Large Plate with First Generation Sensor Installed | 54 |
| 4.6. Post-Test Pictures Showing Partial Contact of Damage Blocks..... | 56 |
| 4.7. Actual Damage for initial Pulse-Echo Sensor Testing | 58 |
| 4.8. Sensor 0072 Pulse-Echo Test Results..... | 59 |
| 4.9. Large Plate with All Sensors Installed..... | 61 |
| 4.10. Initial Pitch-Catch Test Matrix | 63 |
| 4.11. Damaged Areas | 64 |
| 4.12. Damage Testing w/ Stiffener Installed | 64 |
| 4.13. Pitch-Catch Test Results..... | 66 |
| 4.14. Possible Specimens for Future Sensor Testing..... | 67 |

List of Abbreviations

| Abbreviation | | Page |
|--------------|--|------|
| ISHMS | Integrated Structural Health Monitoring System | 1 |
| SE | Systems Engineering | 1 |
| CAF | Coalition Air Force..... | 2 |
| DoD | Department of Defense..... | 2 |
| AFB | Air Force Base..... | 3 |
| METIS | Monitoring & Evaluation Technology Integration System..... | 4 |
| AFIT | Air Force Institute of Technology | 4 |
| AFRL | Air Force Research Lab..... | 4 |
| AV | All Views..... | 9 |
| OV | Operational View | 9 |
| DoDAF | Department of Defense Architecture Framework | 10 |
| IDEF0 | Integrated Definition | 11 |
| ICOM | Inputs, Controls, Outputs and Mechanisms..... | 11 |
| CONOPS | Concept of Operations..... | 17 |
| USB | Universal Serial Bus..... | 33 |
| MDC | Metis Design Corporation | 44 |

A SYSTEMS ENGINEERING PROCESS FOR AN INTEGRATED STRUCTURAL HEALTH MONITORING SYSTEM

I. Introduction

This chapter introduces the background work that was accomplished by a previous thesis and briefly describes the proposed approach as well as the problem and purpose of this thesis.

1.1 Background

A thesis titled “A Systems Engineering Approach To Integrated Structural Health Monitoring For Aging Aircraft” was completed in March 2006 by Captain Allan P. Albert, Captain Efstathios Antoniou, Captain Stephen D. Leggiero, Major Kimberly A. Tooman, and Captain Ramon L. Veglio. That thesis investigated a systems engineering approach “to the development and implementation of a cost-effective, near real-time, integrated structural health monitoring system on aircraft that did not have such a system in place [1].” The thesis accomplished two primary tasks. The first task was the development of an Integrated Structural Health Monitoring System (ISHMS) Systems Engineering (SE) design process. This was accomplished by providing functional architecture products which can be used “to help identify the top-level operational concept and stakeholder requirements of an ISHMS for a generic aging aircraft. The second task was to demonstrate the potential cost benefits of installing an ISHMS on an

aging aircraft. The subject of the research was the Coalition Air Force's (CAF) A-37 aircraft. The authors accomplished the first task by following the SE Vee Model [2] to define the system level design problem and then developing the functional system architecture following the Department of Defense (DoD) Architecture Framework [5,6,7]. To accomplish the second task, the authors created mathematical simulations using data from the CAF A-37 and showed that installing an ISHMS can reduce maintenance inspections while maintaining safety.

1.2 Proposal

Using the March 2006 thesis as a starting point, this thesis seeks to continue and build upon the work accomplished prior. This thesis will seek to apply systems engineering to develop an ISHMS for any generic aircraft. This will be accomplished by further development of architecture products, including physical architectures. In order to verify and validate the architecture products, the thesis group sought to apply the processes in the development of a prototype ISHMS. The ultimate goal is that when used along with the March 2006 thesis, the reader will have a well defined SE process along with architecture products that the reader can use to guide the development of an ISHMS for their particular application.

1.3 Problem and Purpose Statement

Since the work accomplished by March 2006 thesis team concentrated on aging aircraft, in particular the CAF's A-37, the challenge for our thesis team was to take what was already done and to further expand upon that work so that it can be adapted and applied to any aircraft that may benefit from having an ISHMS installed. In this thesis the group wanted to accomplish several tasks in order to achieve the previously stated

goal. The first task was to continue the systems engineering process in the development of functional and physical architectures to complement the architectures in the previous thesis. Secondly, we executed the processes and architectures in the development of a prototype ISHMS in order to verify and validate the processes and architectures. The third task was to use what we learned from the development and iteratively refine those processes and architectures.

1.4 Problem Focus

Although the thesis group is designing a SE process and architecture that are generic enough to be used to design an ISHMS for any particular problem, from the outset, the group wanted to select a real world problem in which the research could be focused. This would enable the group to ultimately apply and test a possible solution that was designed. This process began by contacting the F-15 maintenance depot at Robins AFB in Georgia to ask them what types of structural problems they experience that would benefit from an ISHMS. This initial contact led to the thesis group making a trip to the F-15 maintenance depot, where engineers and maintainers provided hands-on experience with several structural issues that the F-15 was currently experiencing. The group was presented with two promising structural problems. The first dealt with a structural issue in the wing attach lug, and the second dealt with a bulkhead in front of the jet-fuel starter bay. Of the two problems presented, the group selected the problem in which one of the F-15 bulkheads was experiencing an unexpected crack. The group selected the problem due to many favorable circumstances. For example, the structure is critical to flight safety. Since the bulkhead is one of the primary structural elements in dispersing stresses from the wings, a failure of the bulkhead can be catastrophic and

result in the loss of an aircraft. Accessibility to the problem area was another consideration in choosing the problem, and although an ISHMS would be most useful in difficult to reach areas, for the purpose of this research the group wanted an area that would be easy to access. An additional consideration in the decision is the uniqueness of the problem. To date, there has been only one known F-15 aircraft to experience cracking in this bulkhead. This crack greatly concerned the engineers, as the bulkhead cannot be repaired due to its material and design. To replace the bulkhead on a single F-15 would take a great number of personnel, hours, and millions of dollars.

Once the group selected the F-15 bulkhead problem to focus the effort, the group began working towards a possible ISHMS solution for the specific problem at hand. Simultaneously, the group began working on the SE process and architectures. An important part of an ISHMS solution is the sensor selection, and from the various technologies currently available the group was guided towards methods using Lamb waves. The specific technology that the group was guided to use was the Monitoring & Evaluation Technology Integration System (METIS) sensor. There were several reasons that led to the selection of the METIS sensor as part of the research. One reason was that there were others individuals at the Air Force Institute of Technology (AFIT) as well as Air Force Research Lab (AFRL) studying the Lamb wave technology that had yielded promising results [28]. Another reason was that the METIS sensor operating specifications were suited to use for application on the F-15 bulkhead problem. The METIS sensor also came in an easy to use housing where actuator and sensing mechanisms were encased in a complete unit. The entire unit is then bonded to structural surfaces using simple epoxy.

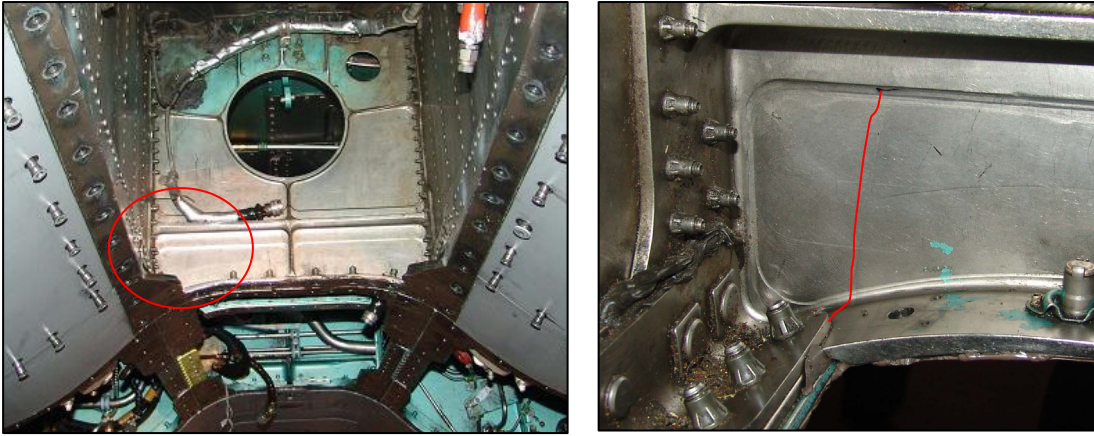

Figure 1.1: Pictures of F-15 Bulkhead With Crack Highlighted For Detail

II. Structural Health Background

This chapter discusses background and some current approaches of integrated structural health monitoring. Included is a discussion of the approach that was studied for this thesis.

2.1 Structural Health Background

Structural health monitoring is an important part of any maintenance program in which the safety and performance of the system is dependent on the integrity of the structure. Having an integrated structural health monitoring system installed on an aircraft would provide numerous benefits. For example, a system could potentially decrease the frequency of required inspections, which translates into cost savings. In addition, another benefit is the added safety margin that a system would give the user. Although there are ISHMS being used in aircraft today, these systems are not as robust as other monitoring systems used in other areas of the aircraft. For example, the avionics or engine monitoring systems are much more robust in terms of being able to provide real time data or warnings to the operators. Current integrated structural health monitoring methods used in aircraft are primarily limited to two methods; First, the collection of flight data for use in trend analysis and fatigue life analysis, and second, the use of sensors, such as strain gauges, to collect structural data for material strength analysis. Aircraft structures are continually being pushed to their limit which leads to an ever increasing need for advanced ISHMS capable of accurately detecting and monitoring structural damage and quickly providing useful data to the maintainers or operators.

2.2 *Current Methods*

A great deal of research is being done into various detection and monitoring technologies and their application in structural health monitoring. Traditional nondestructive methods used in structural crack detection such as visual, fluorescent dyes, eddy current, and ultrasonic inspections are being joined by new methods as technology advances such as methods using Lamb waves. Individuals, companies, and organizations, including academic and government, are continually researching advanced technologies that can be used to monitor and detect structural damage. Equally important is being able to package these technologies into a system that is modular, capable of being adapted to a variety of applications, easy to operate, and has a high reliability and accuracy of detection. One such technology is the METIS which was studied as part of this thesis as a possible ISHMS.

III. System Architectures

This chapter introduces the ISHMS architectures used to create a generic process for the integration of an ISHMS onto an aircraft. The process was created using the DoD Architectural Framework process. The ISHMS process begins with the requirements generation process and is completed with the operation of a system.

3.1 ISHMS Architectures

In this section, architecture products will be presented that demonstrate the development of an ISHMS. The products were created using Popkin's System Architect software. The thesis group chose to develop architectures as a method to understand all the elements necessary to develop the overall system. The group followed the generic six-step process presented in DoD Architecture Framework Version 1.0 [6]. This framework is presented in figure 3.1

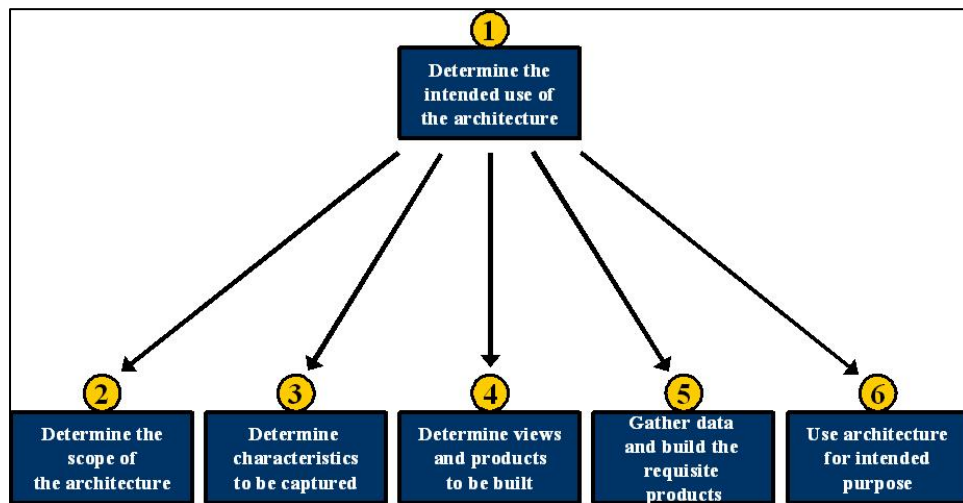

Figure 3.1: Generic Six-Step Architecture Process

3.1.1 Six Step Architecture Process

The first step in the six-step architecture process was to determine the intended use of the architecture. The thesis group decided to build the architecture as a method to present the process of creating an ISHMS. This process would include everything needed from requirements definition all the way through an operational system. The second step in the process was to determine the scope of the architecture. In order to understand the scope of the project, the group needed to determine what the scope of the ISHMS would be. The group decided that the ISHMS would be designed for a specific aircraft structural problem. The purpose of the system is to give post-mission feedback on the current status of that specific structural area. This technology gives the user the capability to decrease the inspection burden and frequency at that particular area. The third step of the process was to determine the characteristics to be captured. The group decided that in addition to capturing the requirements to create an ISHMS, we would also build a physical architecture and then use that architecture to operate an actual system. This operation would give us the capability to determine an operational concept for how the system might be used. The fourth step in the process was to determine the architecture products to be built. The group decided that the following architectures would be built: AV-1, AV-2, OV-1 and OV-5. These products would give us the diagrams needed to depict the process. The fifth step in the process was to gather and build the requisite products. The products will be presented in the following section. Finally, the sixth step of the process was to use the architecture for its intended purpose. The thesis group accomplished this by using the architecture to create an actual structural health monitoring system. This step is described in section 3.2 and section 4.

3.1.2 All-Views Architectures

The first products required by DoDAF are the AV-1 and AV-2, which are textual descriptions of the problem. The AV-1 serves to define the problem and communicates the scope of the problem. The AV-1 is depicted in Figure 3.2. The AV-2 is also known as the Integrated Data Dictionary, and is essentially a glossary of the terms used in the architecture products. The AV-2 is presented in Appendix A.

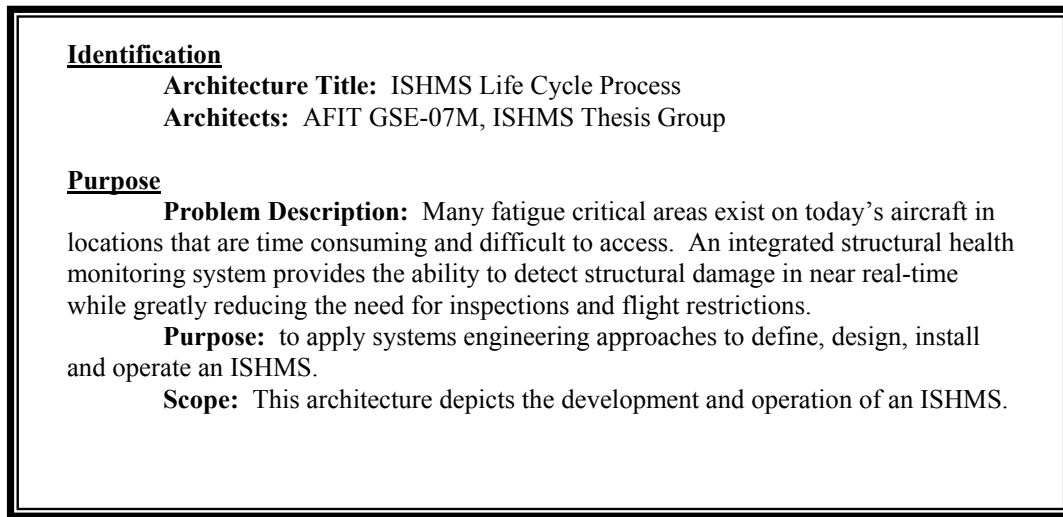

Figure 3.2: AV-1 Architecture

3.1.3 Operational Architectures

3.1.3.1 OV-1: Archi-toon. The OV-1 (Figure 3.3) was developed by the thesis group in order to give a portrayal of the entire system from a high level. Although the architecture supports a generic ISHMS, the thesis group used a picture of an F-15 in the background since the specific problem the group explored was for an F-15 structure. The diagram begins with the structure of interest shown on the left hand side. The structure interacts with the sensor shown in the bottom left via a lightning bolt. The

lightning bolts represent a generic form of interaction. The sensor then sends its data to a software program shown on the bottom right and the software is then used to generate maintenance action. Finally, on the far right side of the diagram, maintainers are performing the recommended action on the aircraft.



Figure 3.3: OV-1 Architecture

3.1.3.2 OV-5: Operational Activity Diagram. The next architecture is the OV-5, also known as the operational activity model or IDEF0. The IDEF0s presented show the functional decomposition of the system as well as the inputs, controls, outputs, and mechanisms (ICOM) for each of the functions.

The thesis team began the architecture development by first defining what the main purpose of the activity model, which is to provide generic systems engineering process for an ISHMS. This purpose was then converted into the overarching activity of monitoring structural health, which is shown on the context diagram in Figure 3.4. Moving down from this top-level function, the process of monitoring structural health was decomposed to the bottom-level functions as will be shown in the following architecture products.

The first step after determining the context diagram activity was to decompose the function into four major functions that need to be performed in order to develop an ISHMS. These four functions are; Define ISHMS Requirements, Design ISHMS, Install ISHMS, and Operate ISHMS (Figure 3.5). At this point it is worth mentioning the point of departure from the previous AFIT thesis group. The previous thesis focused primarily on how to define the ISHMS requirements. This thesis will iterate the architecture further and will include requirement definition as one of the four top level functions, but then will demonstrate how those requirements are then used to design, install and operate the system.

The first step in creating an ISHMS would be to define the requirements. The thesis team decomposed the requirements definition activity into the following: Determine Monitoring Requirements, Determine Data Collection and Processing Requirements, Determine Operational Requirements, and Determine Maintenance Requirements. (Figure 3.6). The monitoring function includes all decisions about the sensors used in the system. The data collection and processing function deals with decisions regarding data acquisition, handling, and processing. Next, the operational

function captures user preferences regarding the actual operational usage of the ISHMS.

Finally, the maintenance function deals with maintaining the ISHMS system.

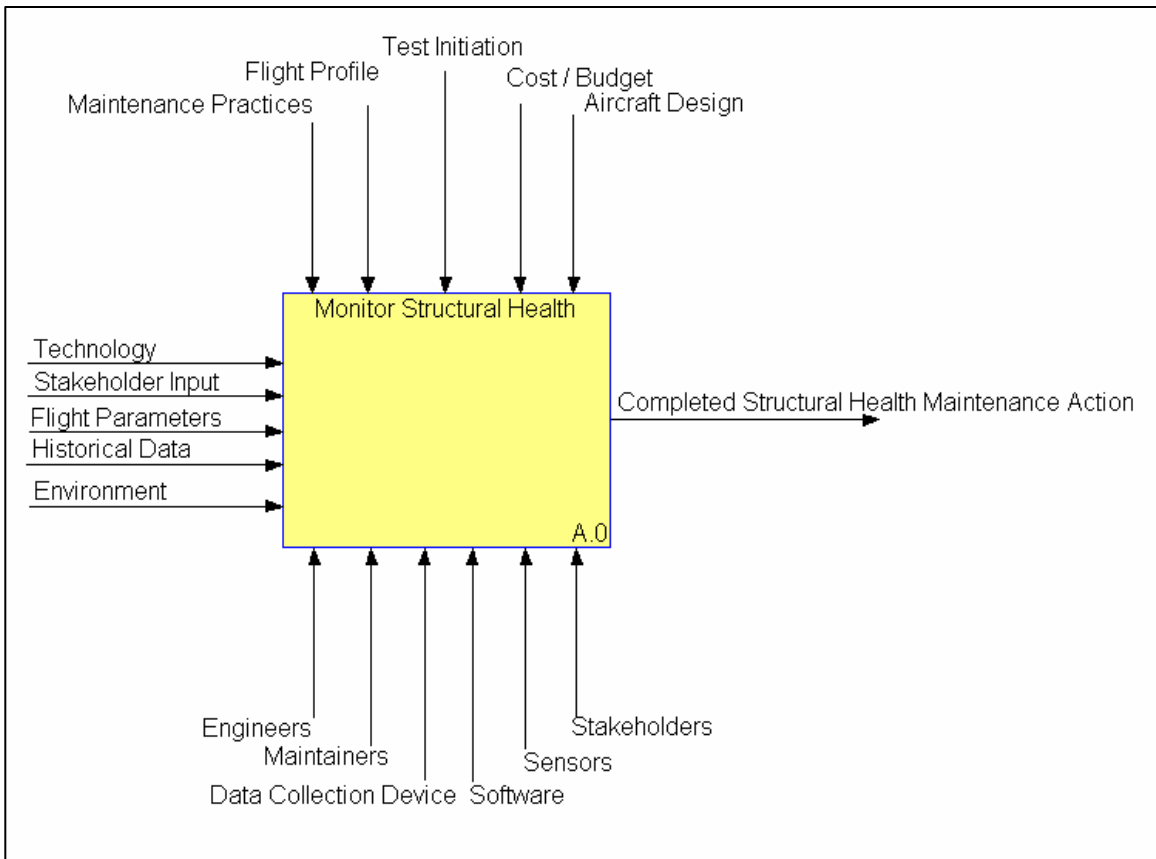

Figure 3.4: Context Diagram

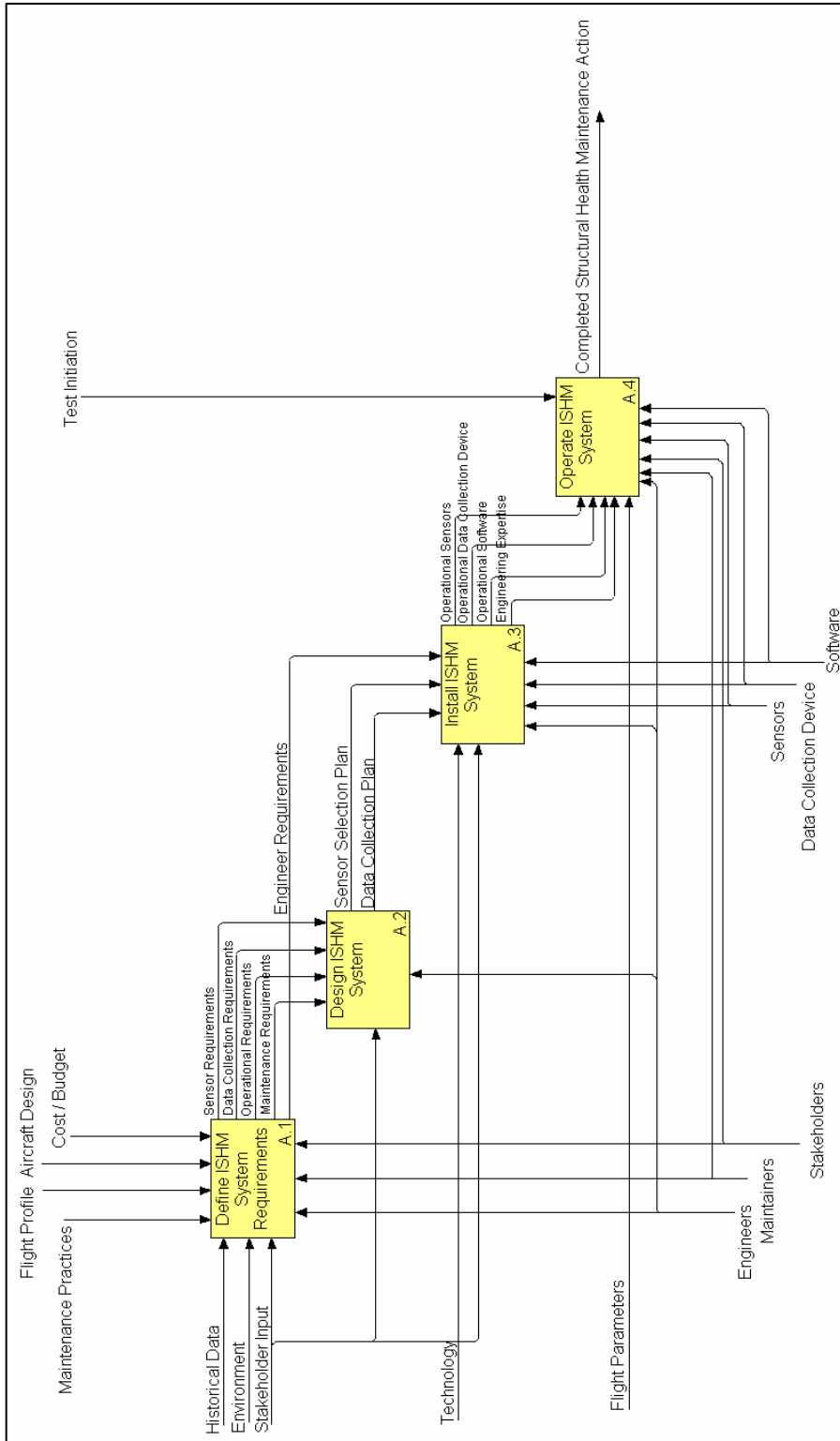

Figure 3.5: A-0 Architecture – Decomposition of Monitor Structural Health

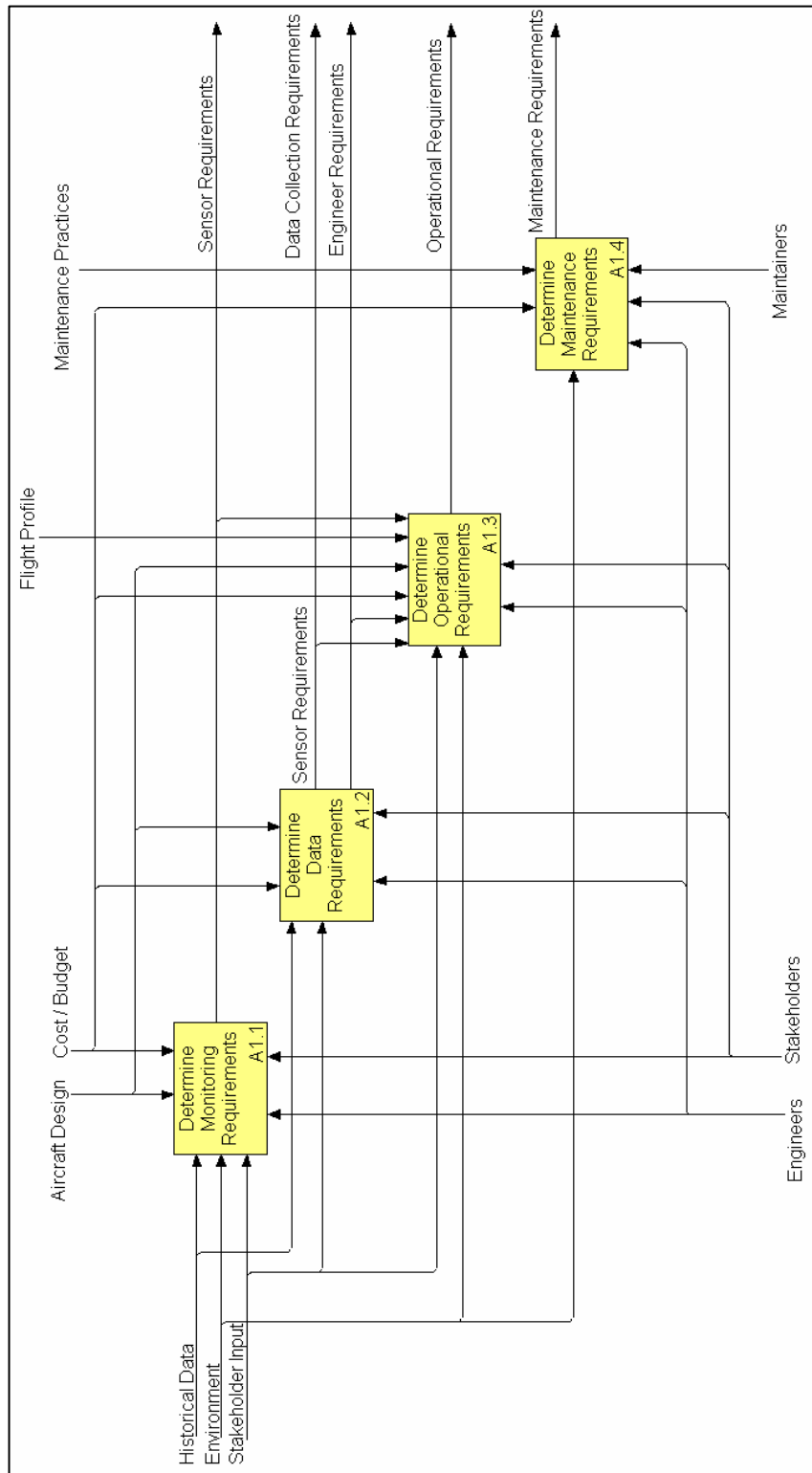

Figure 3.6: A-1 Architecture – Decomposition of Determine ISHMS Requirements

Next, the monitoring function was decomposed further to aid in the user selecting appropriate sensors for the application (Figure 3.7). The monitoring function was decomposed into three functions. The first function is to determine sensor properties. It is critical in an ISHMS to first decide what type of sensors will be utilized, and what properties they possess. Properties such as frequency, sampling rate and amplitudes must be determined before sensor location and quantity can be chosen. Once the sensor properties are known, this information is input into the next two functions; determine sensor location and determine sensor quantity. These three pieces of information form the basis of the monitoring requirements. Next, the data collection and processing function was decomposed (Figure 3.8). The thesis group determined that three things would have to happen to the data that was gathered from the sensors. First, it needs to be stored, so that it can be recalled when needed. Second, the data needs to be processed. Processing includes basic formatting of the data into a usable format. Third, the data needs to be analyzed. Analysis consists of specially trained engineers examining the data and making recommendations on the dispensation of the structural member. These three functions become the activities in the decomposition of the data collection and processing function. Next, the operational requirements function was decomposed (Figure 3.9). Key operational requirements that were identified were size, temperature and vibration. These three items are particularly important on modern aircraft. Each of these areas became an activity on the decomposition. Additionally, this stage is ideal for creating a concept of operation (CONOPS). This CONOPS will describe in detail the manner in which the

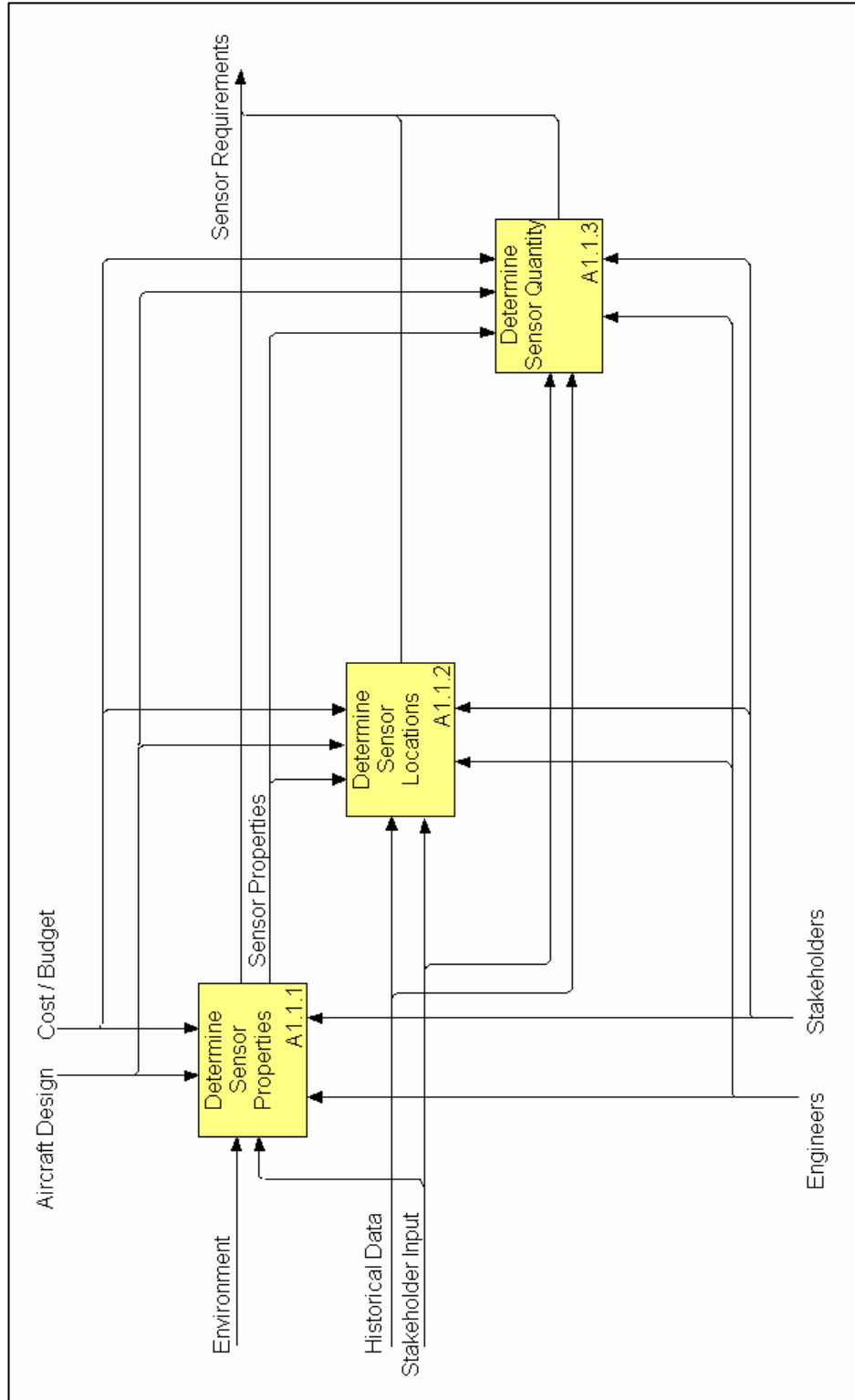

Figure 3.7: A-11 Architecture – Decomposition of Determine Monitoring Requirements

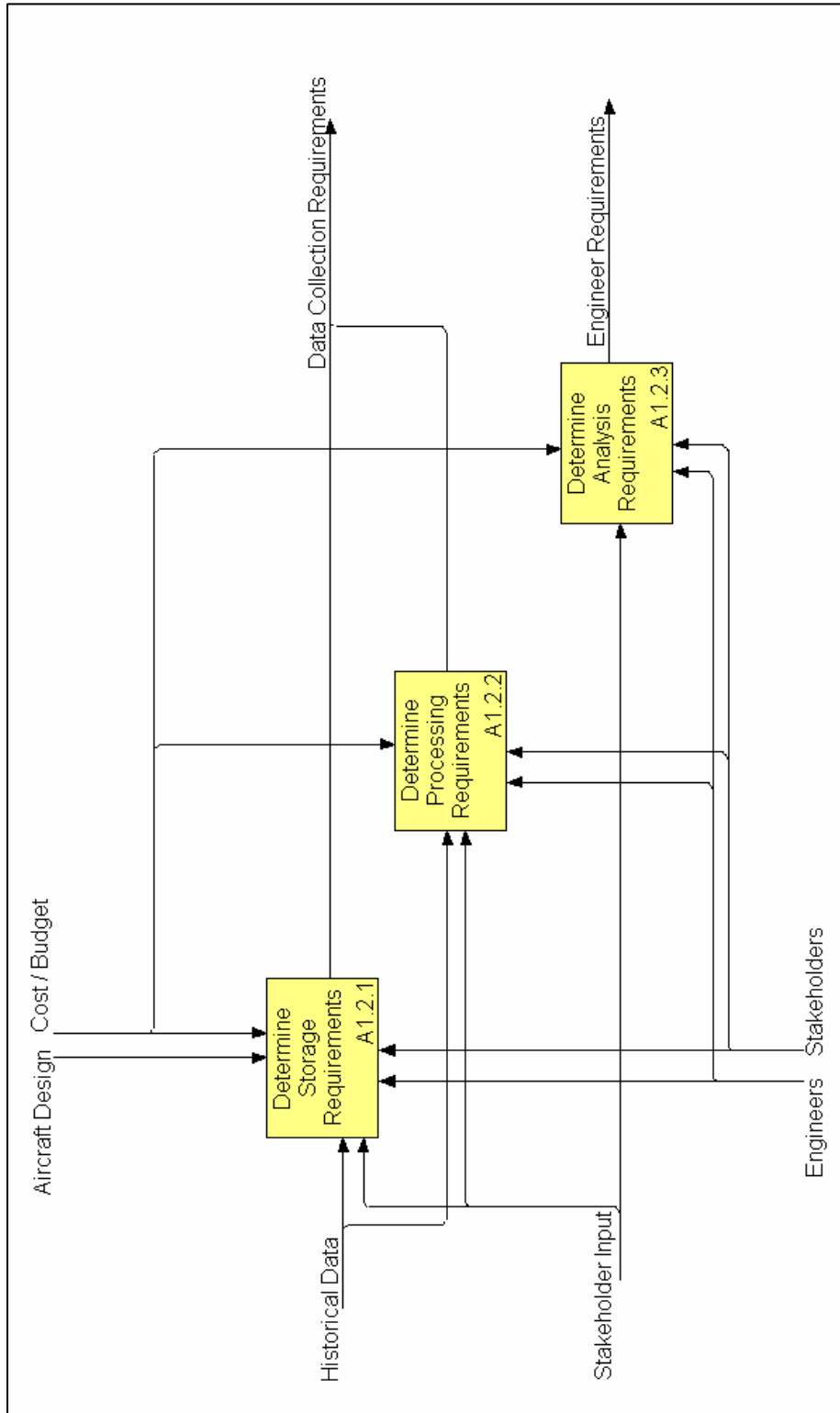

Figure 3.8: A-12 Architecture – Decomposition of Determine Data Requirements

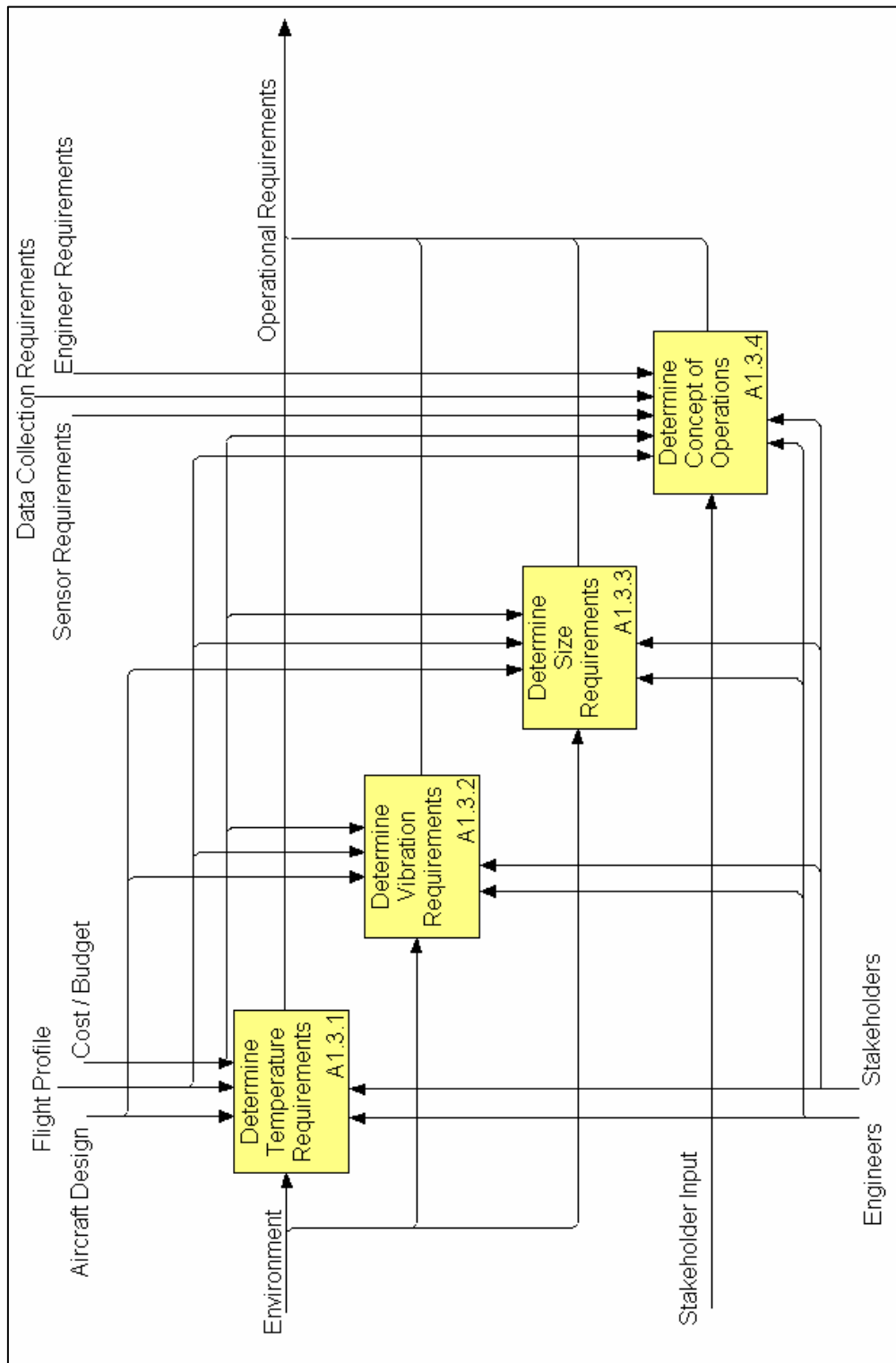

Figure 3.9: A-13 Architecture – Decomposition of Determine Operational Requirements

ISHMS will be used. It will answer questions such as: how often a test is performed, what conditions are required in the hanger as a test is performed, etc. Finally, the maintenance requirements function was decomposed (Figure 3.10). Maintenance was broken up into four key areas. First, with accessibility, it is important to determine how accessible the ISHMS should be. Space is a premium in modern aircraft, and in many cases, certain areas are very inaccessible. Second, durability needs to be considered, as an aircraft tends to be a harsh environment. Third, reliability deals with the probability that a component will not malfunction. Since an ISHMS will dictate the amount of maintenance that will be performed on a specific structure, it is important that the reliability of the system is high. Finally, the maintainability of the system relates to how easy it is to repair when it does malfunction. Ideally, the system will be easy, cheap and quick to fix. These maintenance functions represent the types of capabilities that an ISHMS should demonstrate. They may not represent all of the maintenance functions that are necessary for a particular system.

After defining the ISHMS requirements, the next function in the A-0 diagram is design ISHMS. The outputs from the define requirements function primarily flow into this box, and are transformed by the design function into ISHMS plans. The thesis group decomposed the design function into three main components that need to be designed (Figure 3.11). They are the sensors, the data collection unit, and the data processing software. Each of these activities are triggered by their respective requirements. Upon design completion, the system can be drawn up into complete ISHMS plans. These plans can then be used to acquire the hardware and software necessary to implement the system.

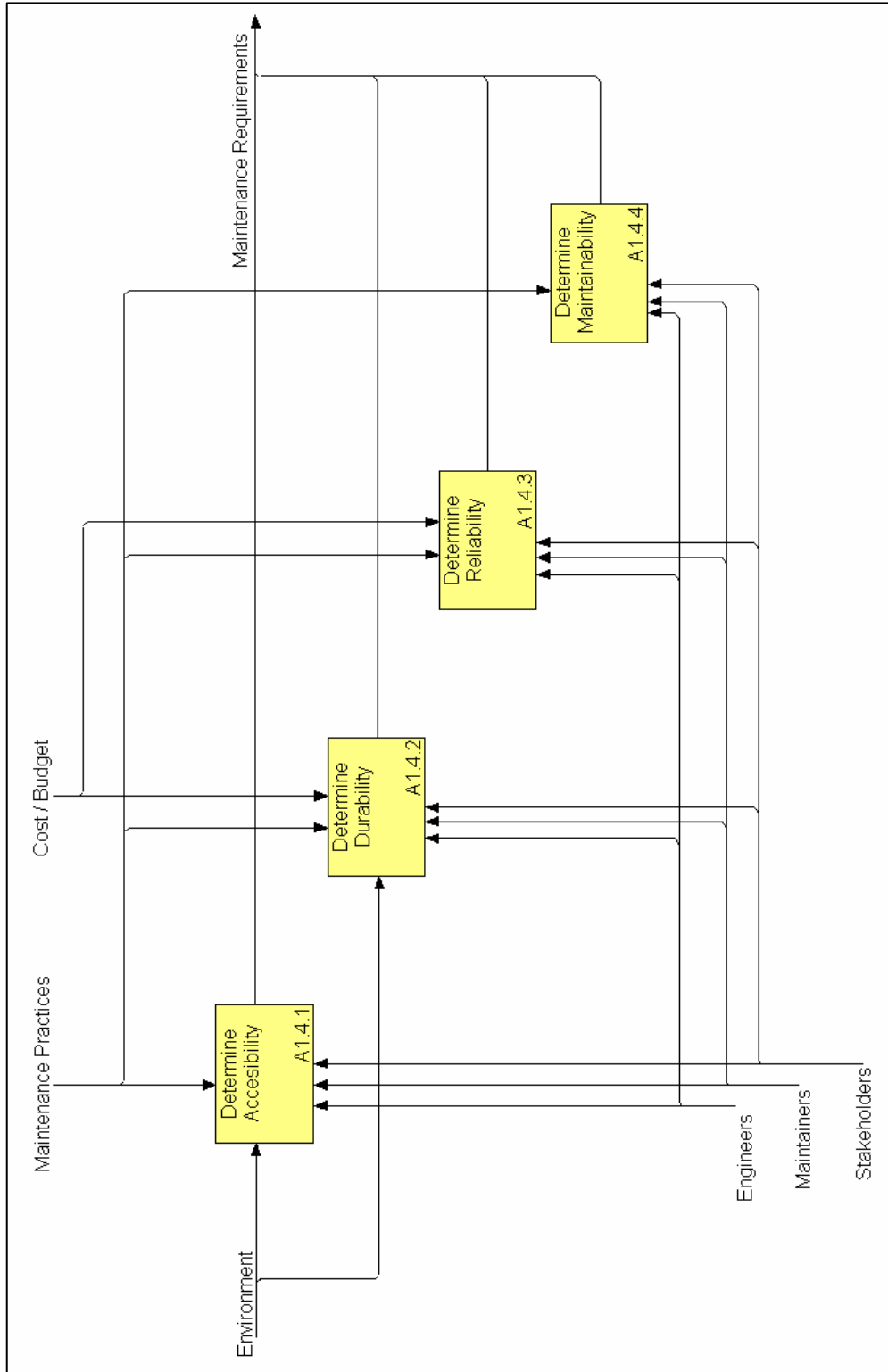

Figure 3.10: A-14 Architecture – Decomposition of Determine Maint. Requirements

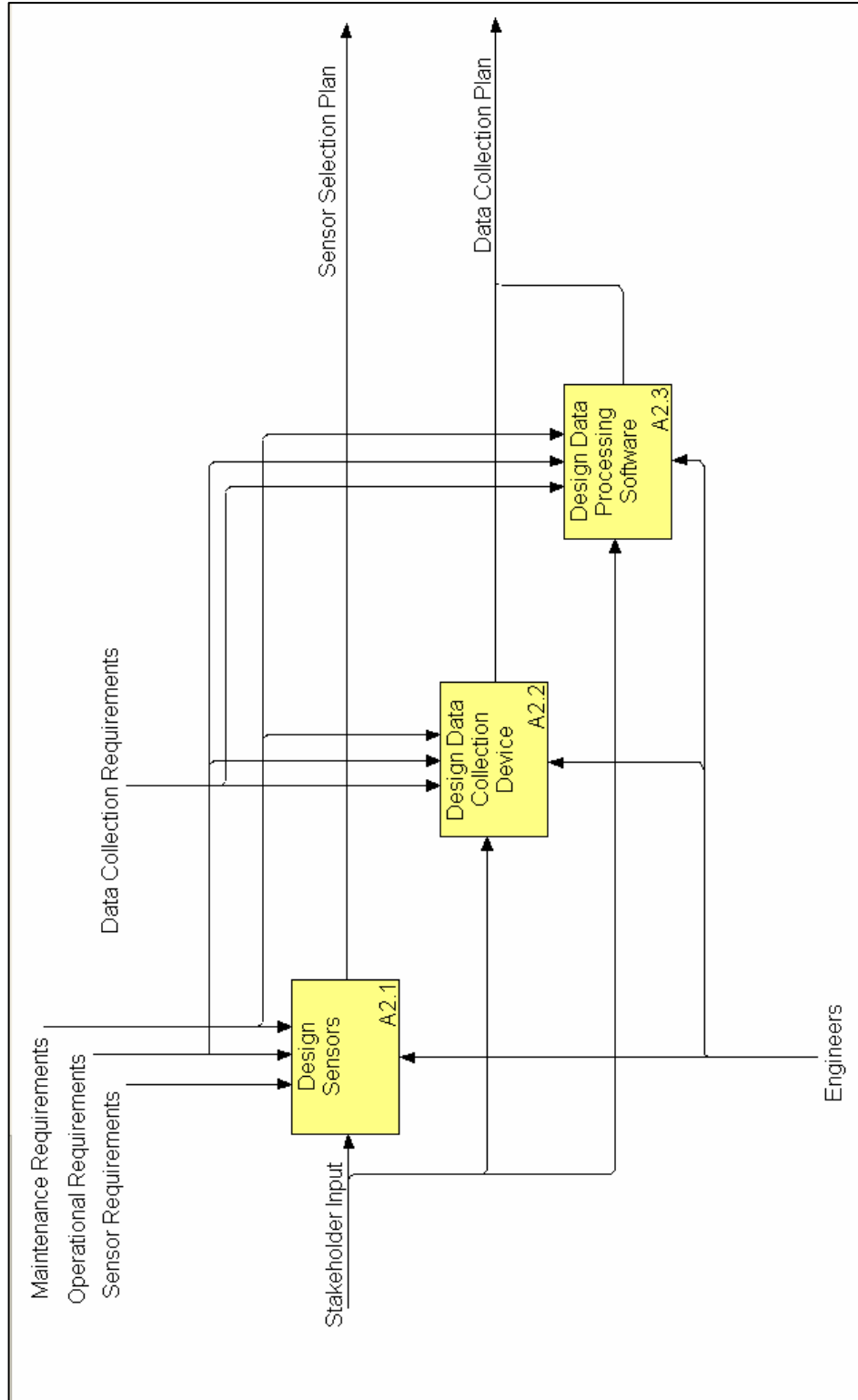

Figure 3.11: A-2 Architecture – Decomposition of Design ISHMS

After the system design is complete, it can be installed on an aircraft. The installation function is the third activity on the A-0 diagram. The install function is decomposed into four functions (Figure 3.12). Similar to the design activity, the install function includes sensors, data collection and software; however the fourth function introduces training for the engineers. The engineer requirements enter this diagram and trigger the training for the engineers. The outputs from each of these functions combine together to form a fully operational ISHMS.

Finally, the last function on the A-0 diagram is the operate ISHMS function. This function is where the structural health monitoring actually takes place. Operate ISHMS is decomposed into four functions (Figure 3.13). These four functions are then each decomposed further to provide added insight into the system operation.

The first function is Collect/Store data. This function is decomposed into two functions, Collect Data and Store Data (Figure 3.14). The Collect Data function is triggered by a test initiation. In practical terms, when an aircraft has completed a mission, part of the post-flight checks will be for a maintainer to plug into the system and run a structural health test. This is equivalent to the test initiation. When the test is complete, a message will be sent to the processing software stating that the test is complete, while sending the raw data to the storage unit. The software will then request the data to be transferred triggering the store data function to release its data. The raw data is then sent on to the second function, Process Data. In this function, the data is formatted into useful information. It may be converted into charts or tables, and is checked for errors.

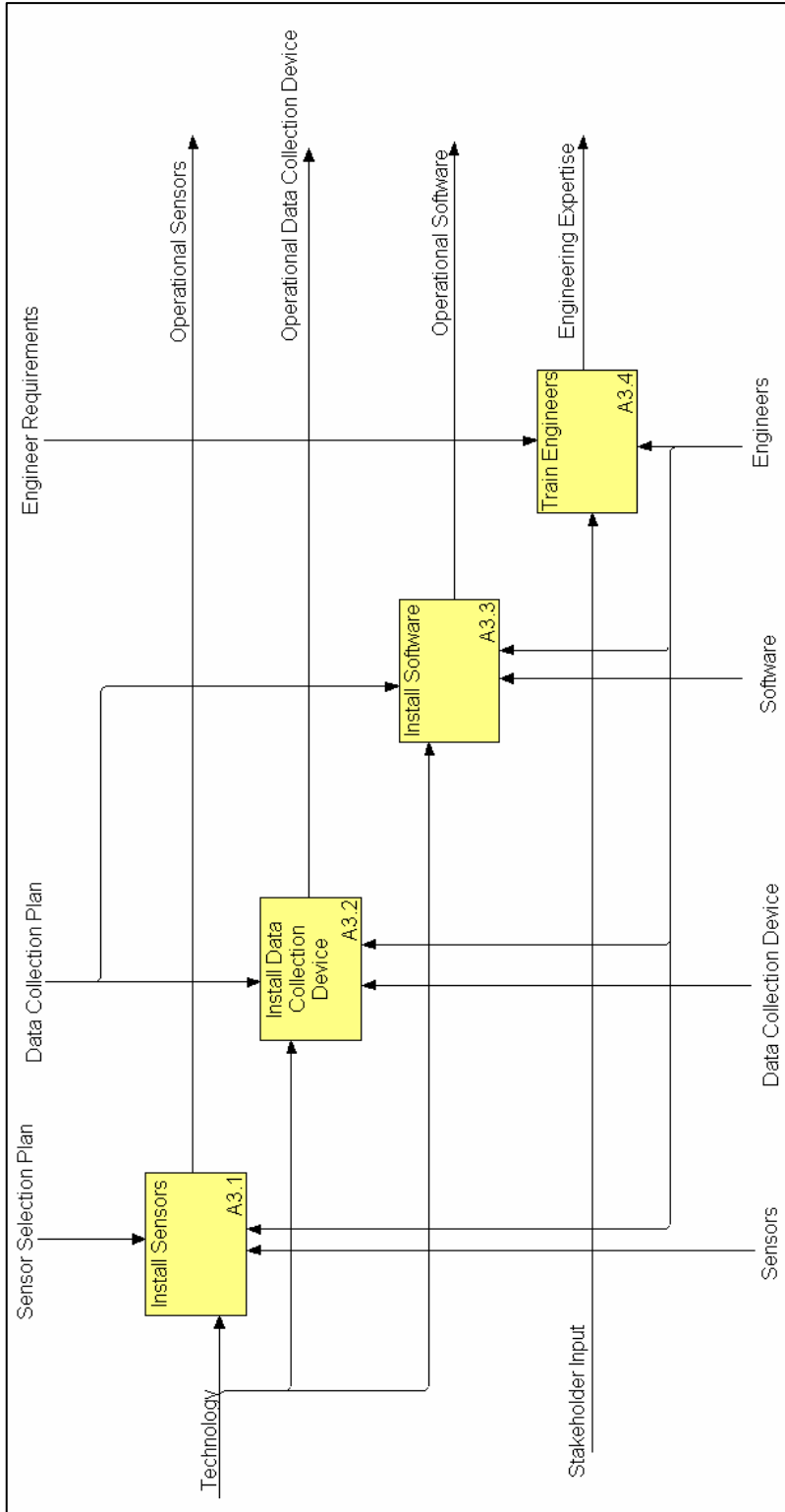

Figure 3.12: A-3 Architecture – Decomposition of Install ISHMS

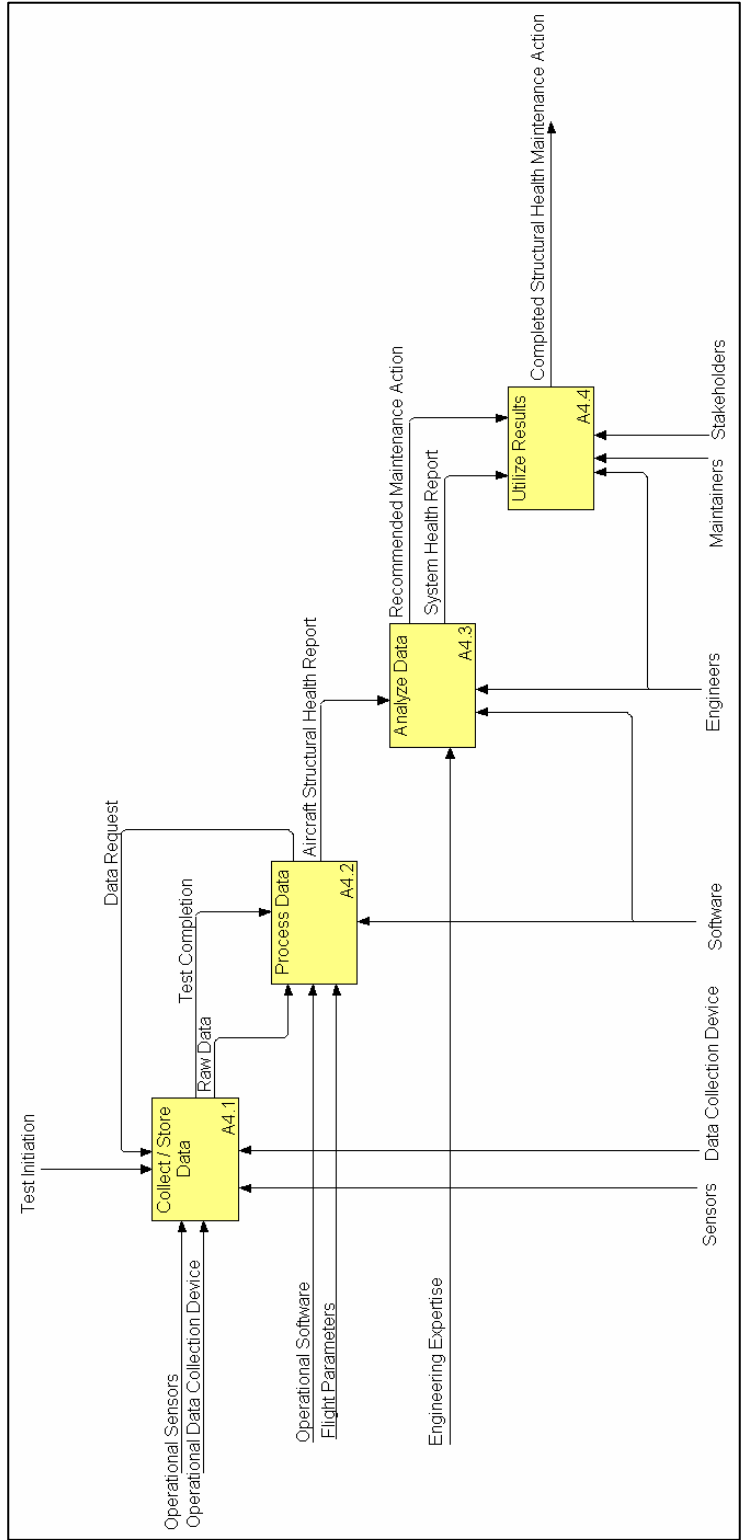

Figure 3.13: A-4 Architecture – Decomposition of Operate ISHMS

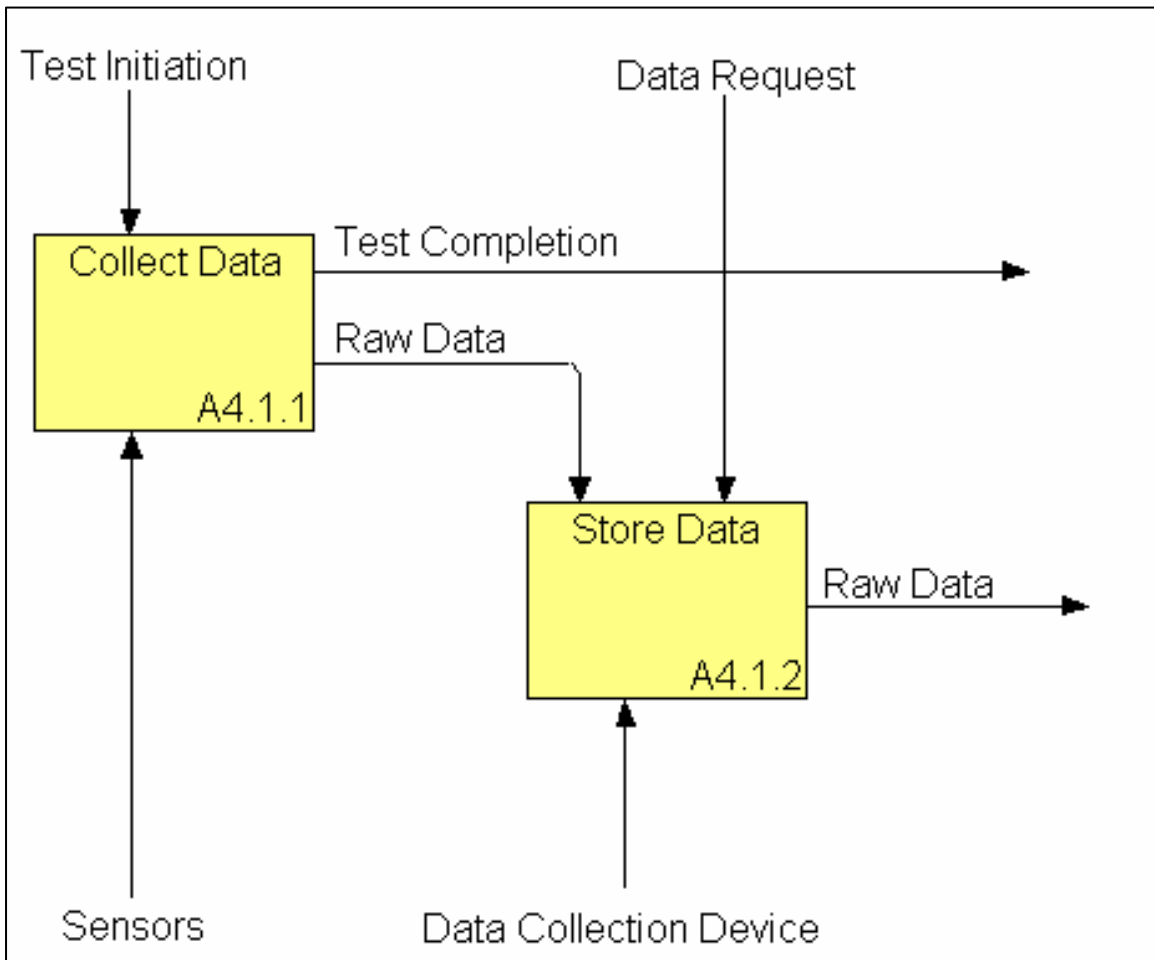

Figure 3.14: A-41 Architecture – Decomposition of Collect/Store Data

The Process Data function is decomposed into four functions (Figure 3.15). The first function is Compile Flight Data. In this function the raw data is correlated with the flight parameters of the particular mission to ensure that the data makes sense. It also checks the data for errors. This filtered data is then sent on to the next three functions simultaneously. In the first of these functions, Run Mission Processing, the data is pieced together with the mission parameters. Trends such as g's, speeds, and number of takeoff and landings are reported with the data for use in trend analysis. In the second of these functions, Run Aircraft Historical Processing, the data is compared with other data from the aircraft history. This will give the analysis engineer a history of the aircraft's structural problems. Again, this data can be used in trend analysis to determine if something specific is causing the structural problems over time. Finally, in the third of these functions, Run Fleet Historical Processing, the data is compared to other aircraft in the fleet. This is used to determine if a problem is an isolated incident for a particular aircraft, or if it is a consistent problem for the type of aircraft. This data is then compiled and output to the next function in the form of an Aircraft Structural Health Report.

The third function, Analyze Data (Figure 3.16), is where the engineers examine this report and make their recommendations. This function is decomposed into five functions. The first three functions are all different forms of analysis done by the engineers. The data is first analyzed to determine if a structural health problem is present. The data is then run through trend analysis software to determine if any trends are developing in the aircraft or in the fleet. Finally, a detailed analysis is accomplished if a

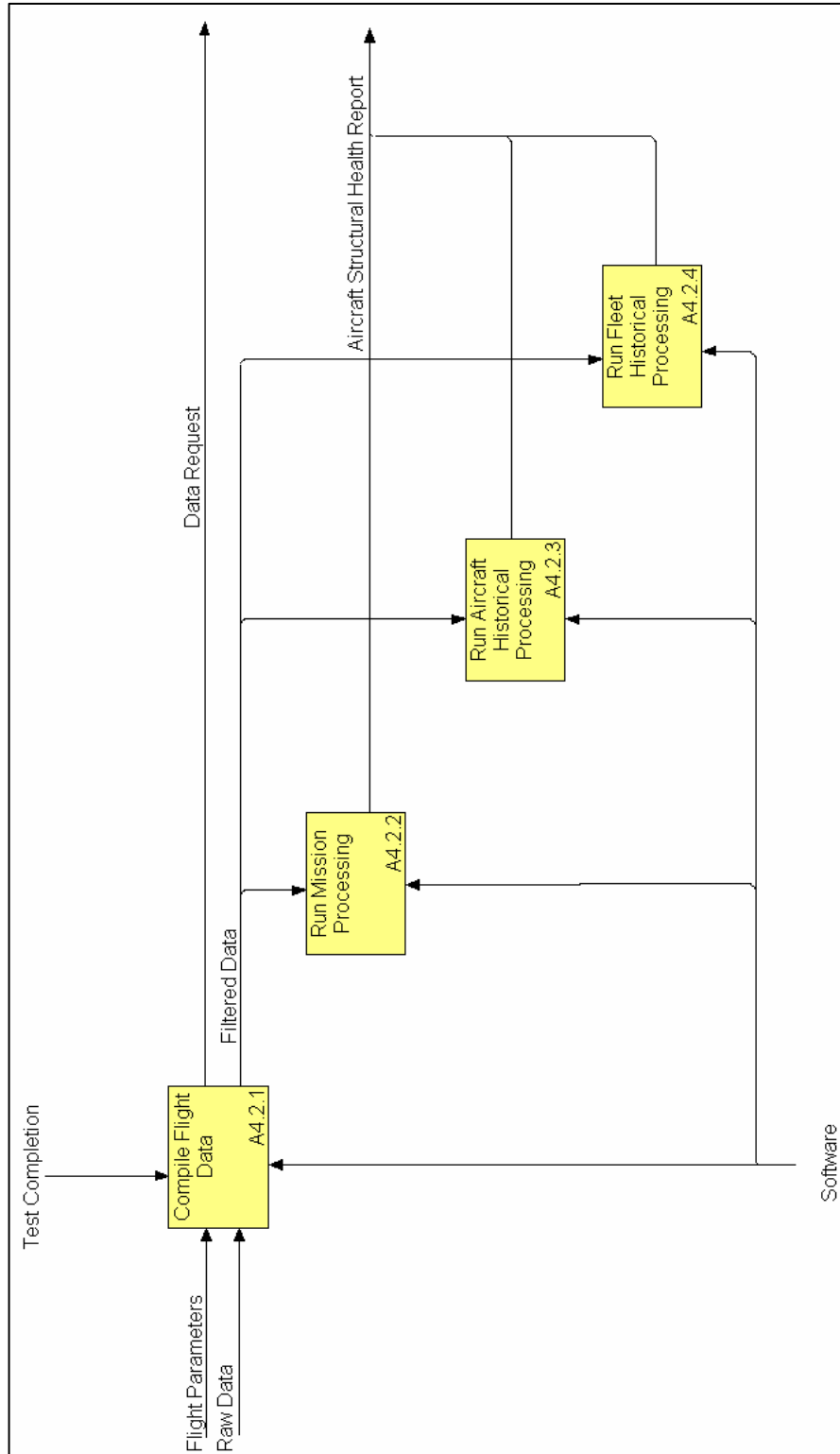

Figure 3.15: A-42 Architecture – Decomposition of Process Data

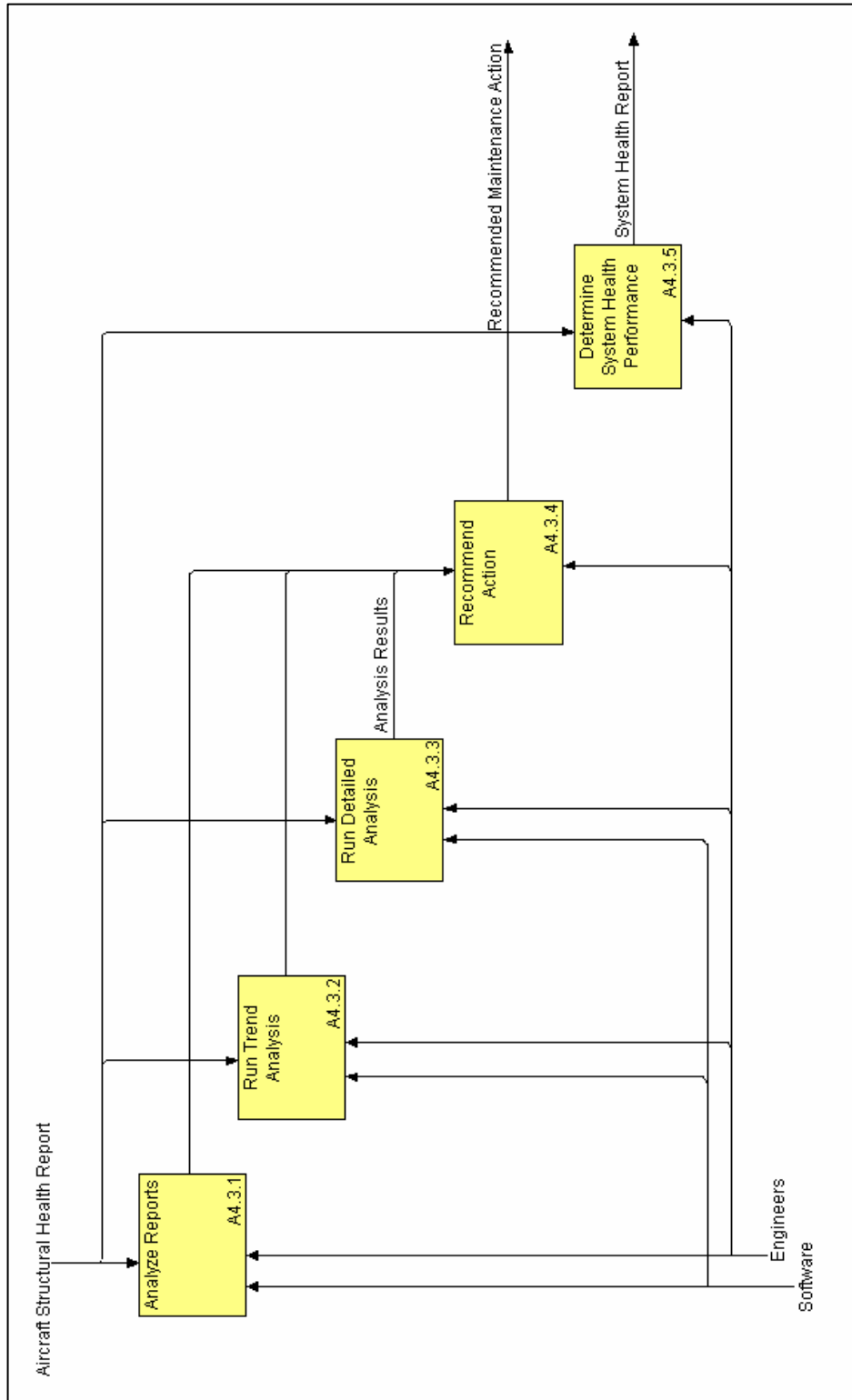

Figure 3.16: A-43 Architecture – Decomposition of Analyze Data

structural problem is found. In this function, the size, location, and criticality of the damage are reported in as much detail as possible. These analysis results are compiled and then sent on to the Recommend Action function. In this step, the engineer uses all resources at hand to make a recommendation on the issue at hand. This recommendation may be to do nothing, or to inspect or repair the area, or to place a flight restriction on the aircraft or fleet. Finally, in the last function, Determine System Health Performance, the engineers use the data to make a determination of the health of the actual structural health monitoring system.

Finally, the fourth function is to Utilize Results (Figure 3.17). This function is decomposed into four functions. The first function is Generate ISHMS Maintenance Action. This function is triggered by the System Health Report from the analysis function. If a determination is made that the ISHSMS is not performing adequately, then maintenance will be performed on the ISHMS to return the system to full operating capability. The second, third and fourth functions are all different types of maintenance action on the specific aircraft or fleet. These actions may include new inspection requirements or shorter inspection intervals, new aircraft or fleet flight restrictions, or maintenance actions on the specific structure of the aircraft. Upon completion of any of these, the final output of the system is a Completed Structural Health Maintenance Action. At this point, the aircraft is declared ready for normal operation, subject to any new inspection intervals or flight restrictions, and the structural health monitoring process is complete.

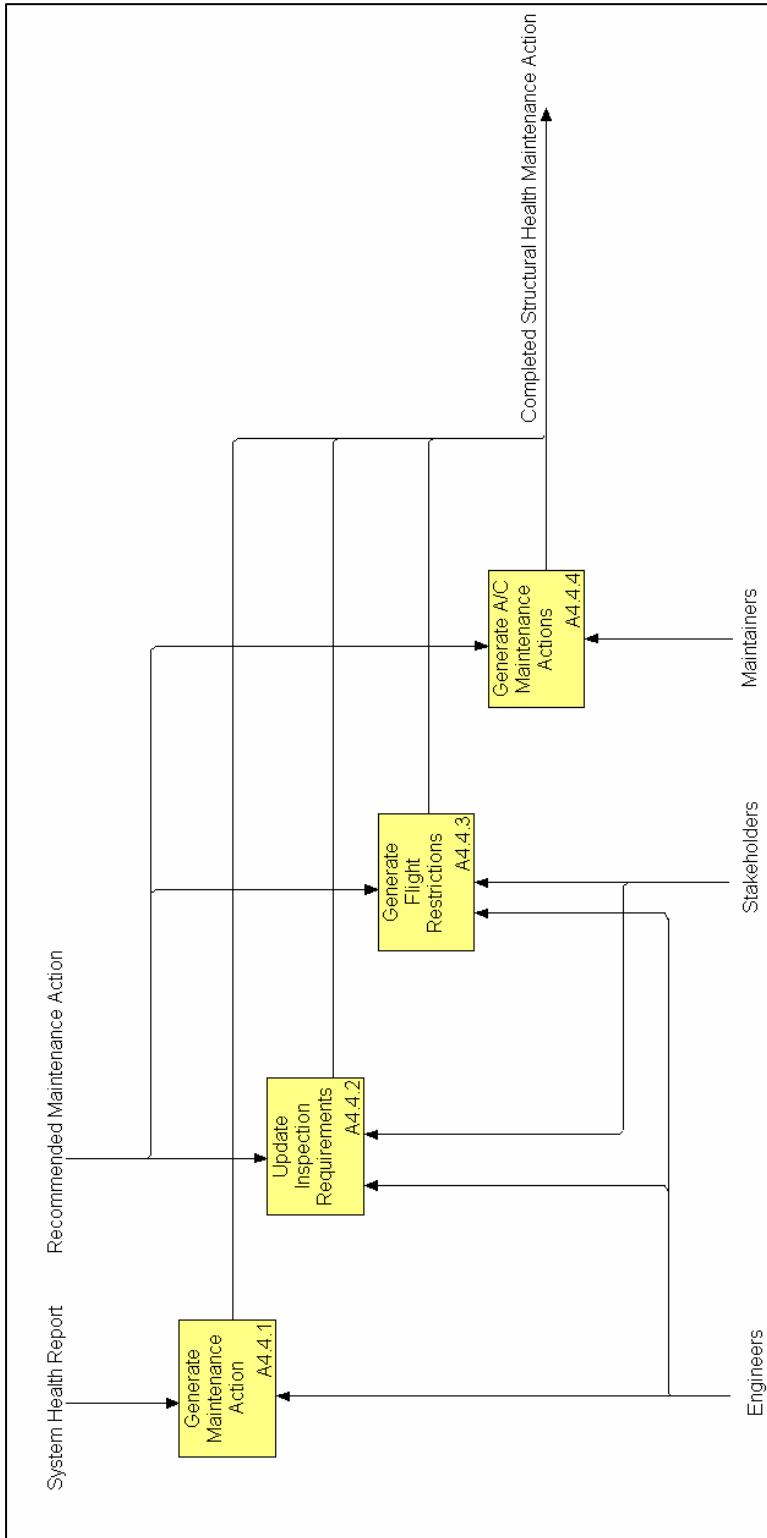

Figure 3.17: A-44 Architecture – Decomposition of Utilize Results

3.2 Architecture Instantiation

After the architecture had been completed, the thesis group wanted to use it to guide them in the creation of a prototype ISHMS. Upon completion of this process, the thesis group would then be able to iterate the architectures further to include anything that was missed the first time through.

3.2.1 Requirements Definition

The first steps in creation of the ISHMS involve determining the requirements of the system. This process was largely accomplished in the previous thesis. In our case, in order to determine what our requirements were, we needed to determine what the purpose of our system would be. After speaking with F-15 engineers at Robins AFB, the group had a few ideas about potential trouble spots on the F-15. For the purposes of this thesis, the group chose an aft engine bulkhead that was cracking in the Jet Fuel Starter Bay. This area turned out to have a very complex geometry that makes structural health monitoring difficult, but it was chosen since it was easy to access, and had environmental requirements that were thought achievable. The primary environmental driver for this area was the high temperatures experienced in the bay. Therefore, the primary requirement that needed to be fulfilled was a high temperature capability. It also needed to sense at certain rates and frequencies that were deemed acceptable. Once these attributes were chosen, the next step of the process was to select a data collection device. In this step, an assumption was made that whatever sensors were chosen would need the capability to be hooked up to an ordinary laptop via USB. Therefore, in this case, the data collection requirements that needed to be fulfilled were simple. The thesis group only required a laptop with a USB input and with sufficient storage and speed. Finally,

the group had to determine the operational and maintenance requirements. In this step, the group had to determine what portions of an actual aircraft ISHMS would be replicated. We decided that our setup would be a simple aluminum plate that would be damaged. The conditions of the laboratory would be similar to the environment in an aircraft hanger. Therefore, we would make no attempts to reduce noise or temperatures. The tests would be conducted without any special conditioning. Essentially, our operational requirements boiled down to a simple hanger-like environment. For maintenance conditions, we were only truly concerned with the reliability of the sensors. We did not want a sensor that would be prone to break or malfunction. This was primarily to guard against false test results. The group did not address other potential maintenance requirements, since the test system was used only in a lab environment. After determining these initial requirements, the thesis group found it necessary to develop our vision for the operational concept.

The operational concept is a step-by step walkthrough of what would be accomplished in creating an ISHMS. The first steps involve determining requirements by working with the users and stakeholders. After the requirements are defined, the system would be designed to meet the needs of the specific structure being tested. After the system is designed and fabricated, it will be installed on the aircraft and prepared for operational use. Once the system is ready, operational usage will then be accomplished as described in the following narrative. After each flight, the aircraft will return to the hanger in normal fashion. During the normal post-flight inspection, a maintainer will use a laptop to connect to the sensors. The maintainer will begin by verifying that the sensors are functioning properly. The maintainer then runs the test or tests as determined

during system development and collects the data from the sensors. Upon completion of the test, the maintainer may disconnect from the sensor and continue to other sensors until all scheduled inspections are complete. The tests will be taken under normal hanger conditions, so the system must be able to filter out typical noise. The raw data from the laptop is then transferred to a central database where engineers use software to process the data and analyze the results. After data analysis is complete, the engineer directs a course of action. This course of action may include additional inspections, flight restrictions, or maintenance on the aircraft, the fleet or ISHMS. This process is then repeated as necessary or upon completion of every flight. The operational concept serves to guide the thesis group's ultimate goal of creating a functional ISHMS.

3.2.2 System Design

After the requirements were complete, the next step in the process was to design the system. The first design step is to choose sensors. The sensor technology that the thesis group had chosen to use was the METIS sensor. This was primarily due to the technology being readily available and from recommendations from other structural health researchers including Maj. Swenson, Capt. Crider, the University of Dayton, and AFRL/VA and AFRL/ML. After selecting the sensor, the group needed to determine how the sensors were going to be used and how many of them we would need to run the tests. We determined that we would begin with a single first generation sensor that would enable us to use the pulse-echo method of testing. This sensor would be attached to a large aluminum sheet. Damage would then be simulated on the sheet until the group gained confidence to read the results. Next, actual damage would be introduced in the

sheet. In addition, three second generation sensors would be applied to the other end of the aluminum sheet.

These sensors would be used for the pitch-catch method of testing. Again, damage would be simulated between the sensors, eventually progressing to actual damage as the technology is understood further. Now that the thesis group had chosen a sensor suite, the next step was to design the data collection device. Due to the requirements imposed on the data collection device, the group simply needed a laptop with a USB port and sufficient storage capacity. Finally, a software package would need to be designed for the system. One of the benefits of choosing this specific sensor was that the manufacturer had also developed a software package. This software package was able to read the data from the sensors and display it on the screen. It also saved the data in an array, making it easy to manipulate. The only portion of the software that needed to be designed further was the analysis package. The software that came with the sensors had no capability to input multiple signals from different tests for comparison. Capt Steve Crider had been working with these sensors on some different tests and had developed a Matlab code that would read in data files from a healthy and damaged specimen and display them simultaneously. It would also display a difference plot that was useful in determining where the damage was located. His software also allowed you to input the location on the plate that was damaged, and it would predict where the major differences would appear. Through data sharing and cooperation, the thesis group was able to use his code to generate test results in exchange for the thesis group running multiple tests for him to use. The entire lab setup is shown in figure 3.18



Figure 3.18: Picture showing the laboratory setup of the test plate

3.2.3 *System Installation*

The final step before being able to test the prototype system was to install each of the components. The first item installed was the sensors. These were attached with standard two-part epoxy. The epoxy was applied to the sensor and then held firmly in place on the aluminum until the epoxy cured. The software was then installed on the laptop. After software installation, the sensors could be connected via USB to the laptop. The thesis group then did some initial testing in order to become familiar with the software. This served as training for the thesis group.

3.2.4 System Operation

With the ISHMS system installed and fully operational, the thesis group was able to proceed with operation. To begin, the thesis group set up the initial test in the laboratory. Using the METIS software, the test was initiated. Upon completion of the test, the software notifies the user of completion. Meanwhile, the data is sent to the computer for storage. The user then requests the data from the system, and the computer then displays the raw data. The next step that the thesis group took was to compile the data. In this step, the test conditions were recorded along with the raw data. The test conditions included actuation frequency, sample rate, number of samples, size and location of damage, and sensors used. In the architecture, the next step is to run mission, aircraft, and fleet processing. Since the thesis group was not using an actual aircraft to run, the only processing done at this point was to compare the data against previous undamaged results. The next step was to take this filtered data and analyze it for structural damage. The architecture attempts to capture all of the various types of analysis that might be accomplished with an actual ISHMS, however in the thesis group experiment, various methods were used for different tests. The primary analysis method used by the thesis group was to plot a healthy result and a damaged result on the same axes (Figure 3.19). This would allow the user to see differences in the frequency response of the material. Additional plots were made that showed the numerical differences between two separate tests (Figure 3.20). Although the thesis group had limited success in conclusively determining whether damage was present, the concept proved promising. The thesis group believes that many factors contributed to the lack of definitive results.

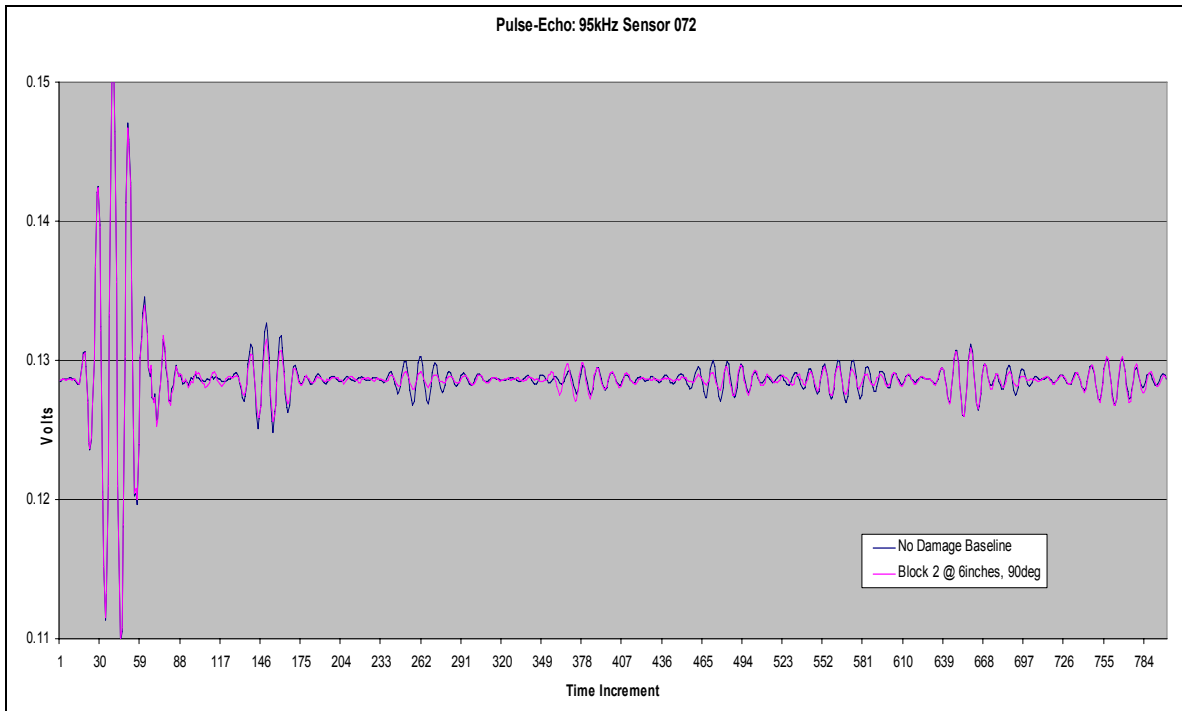

Figure 3.19: Healthy and Damaged Plot on same axes

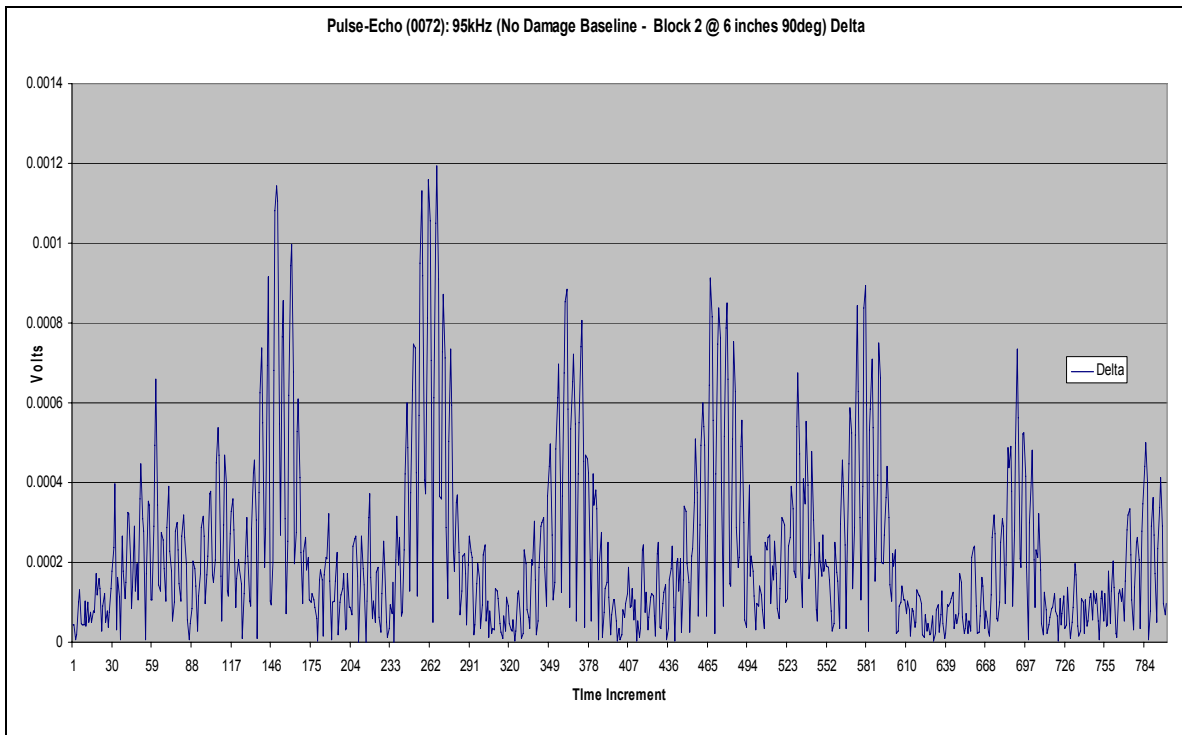

Figure 3.20: Difference between Healthy and Damaged Plots

For example, the thesis group believes that the thickness of the plate deterred lamb waves from propagating through the plate effectively. Additionally, different boundary conditions for each test may have played a role in the accuracy of data. The thesis group did not attempt to control boundary conditions at a strict level, as they attempted to replicate the type of environment that an aircraft would be tested in. Finally, after analyzing the results of the testing, the thesis group was able to make a judgment on whether the damage was detectible for each specific test. This action constituted the groups' recommended action, although no effort was made to repair or categorize the damage, since this test was simply for concept demonstration purposes. Upon completion of the testing, a maintenance action would follow a test in which damage was discovered. Apart from this final step, the thesis group was able to utilize the ISHMS architecture to set-up and operate a basic ISHMS. Although the laboratory set-up was simplified greatly, the concept of an ISHMS installed on an aircraft was proven successfully.

IV. Sensor Integration

This chapter introduces demonstrates the methodologies used to integrate the METIS sensors into a functional ISHMS. The group began testing with the first-generation “pulse-echo” sensors, and ended with the second generation “pitch-catch” sensors in a complex structural test setup.

4.1 Introduction

One of the primary considerations in defining and designing an ISHMS is the selection and integration of the various sensors that will be used to gather the data that is required in order for the system to function. Part of any requirements definition and design process involves assessing the available resources as well as any future “enabling” technologies which may provide increased capability to the system under consideration. One of the primary drivers in the recent employment of ISHMSs has been the development of new sensors with increased capability, not only in terms of the information they can provide, but also with respect to their size and reliability. Many cutting edge technologies are currently being integrated into hardware packages that enable their use outside of a laboratory environment. Some of these new sensor packages have been proven, while many more are still in a prototype phase of development. Identification of these technologies initiates its own iteration of the systems engineering process already underway, a smaller undertaking within the larger scope of the ISHMS effort. A promising sensor technology must be assessed not only on its viability for the task at hand, but must also with respect to its maturity, availability, supportability and robustness to perform in the intended environment. In many cases, these issues are

defined in terms of overall risk to the project vs. the potential payoff that the expected data will provide the user. As is the case with many cutting edge technologies, a parallel path will usually be taken in the requirements definition and design phase of the project which will allow for the integration of the latest hardware, while at the same time, maintaining a proven design baseline with less capability as a backup. Often, separate developmental, or risk reduction efforts are undertaken with new technologies in parallel with the development of the overall system. Even though the development effort of the new technology will follow a separate systems engineering process, the overall ISHMS effort is very much dependant of the outcome of the smaller effort, which will in turn be driven by the performance, cost and schedule constraints of the main process.

The systems engineering process undertaken in this thesis includes such an effort as described above. During the selection of a real-world problem to act as the requirements driver for our system, an emerging sensor technology was identified with the potential to provide excellent damage detection capability and ease of operation. It was decided that this thesis group would undertake a parallel effort to determine the potential for integrating this technology into the ISHMS, and conduct tests to try and establish the “real world” capability of the prototype sensor package.

4.2 Damage Detection using Lamb Wave Propagation

The potential for using Lamb waves to detect damage in solid structures has been the focus of much recent theoretical research and laboratory experimentation. Simply stated, a Lamb wave is a phenomenon wherein a waveform of the appropriate shape propagates through a solid material in a uniform manner. Because of their shape, these waves do not decay quickly as they spread out through the solid medium. Since the lamb

wave travels through the solid as an elastic phenomenon, it is affected by the properties of the material. When a structural element is damaged, it experiences a dramatic and highly localized change in material properties. A Lamb wave traveling through the damaged element would be affected in two ways. First, a physical change in the material such as a crack or impact damage would generate a reflection, altering the pattern of travel of the wave. Secondly, the localized change in material properties would serve to attenuate the wave as it is passed through the damaged area, affecting both the amplitude and the frequency of the wave. The resulting theory is that if a Lamb wave could be sent out into a solid material (such as an aircraft structural member) and then be recorded as it traveled through the material then changes in the material would generate a different “signature” as the Lamb wave was recorded over a period of time.

Many theoretical studies have been completed, verifying the existence of Lamb waves. Additionally, much experimental work has been, and continues to be accomplished which validates the theory in actual practice. Typical experimental setups employ piezo-ceramic wafers as both the actuating and sensing elements. A Lamb wave is generated from one node, and is recorded at one or more nodes according to the configuration of the test specimen. The capability of these systems is highly dependent on the structural element being tested, both in terms of the material properties and the physical geometry. The material properties of the specimen affect the maximum range that the Lamb waves can travel and the frequency requirements for generating the wave. The physical geometry of the specimen also affects the range of the waves, but may also additionally restrict the possibilities for sensor placement. As is true in any structural analysis, the more complex the overall system, the more difficult it is to properly identify

the optimal wave shape, frequency and sensor location. Recently, there have been efforts made to package this technology into a sensor package for use in real-world situations.

4.3 METIS Sensor Package

One such sensor package is produced by the Metis Design Corporation (MDC) and has been procured in limited quantities by AFRL and AFIT for the purpose of further exploration into their potential. The METIS sensor is a self contained package that uses piezoelectric wafers to send and receive Lamb waves through the structural element to which it is bonded. All the necessary components for controlling the sensor are built into the disk which is housed in a 3cm diameter by 1cm thick enclosure. The sensors received for this evaluation are powered and controlled through a standard USB cable, although wireless models powered by a thin-film Lithium polymer battery are also in development. The sensor is controlled through a provided software interface which allows the user to perform tests at any frequency, amplitude, or wave form desired within the capacity of the sensor. The software also allows the user to collect data using the average value of multiple consecutive data runs which can be selected via the user interface. The METIS sensor can be operated in two distinct modes; Pulse-Echo, and Pitch-Catch. In Pulse-Echo mode, a single sensor sends out the predefined signal (Pulse) from the actuating disk, and records the resulting signal (Echo) through the receiving disk from the structural element. In Pitch-Catch mode, a pair of sensors is utilized, with the first sensor sending out the signal (Pitch) from its actuating disk with a second sensor recording (Catch) the signal through its receiving disk. In Pitch-Catch mode, the actuating sensor is also recording data through its receiving disk, in essence acting as a Pulse-Echo sensor as well.

4.4 Test Methodology

As mentioned above, previous testing with the METIS sensor had verified the ability of the system to detect damage in a simplified structural element. The primary objective of this thesis group was to determine if the METIS sensor could function in a more realistic, i.e. more structurally complex environment. As described previously, the design driver for our ISHMS was the F-15 bulkhead crack discovered on a single operational aircraft and currently being studied. A secondary objective of this experiment was to try and determine just how sensitive the sensor was with respect to the size of the damaged area. Along the way the group would also be evaluating the software interface, and trying to establish any undesired correlation between our test methodology and the data produced. Initial discussions centered on the actual structural element that would serve as the platform for our testing. Several designs were produced with simplified versions of the bulkhead flange, shear web, and longeron attach joints. Producing a specimen that could be placed in a test cell and subjected to cyclic loading was briefly considered, but ultimately not pursued since it provided no direct benefit towards answering the main question of sensor capability. During this time frame a section of an actual F-15 bulkhead was requisitioned from the Aerospace Maintenance and Regeneration Center at Davis-Monthan Air Force Base. This bulkhead is shown in Figure 4.1

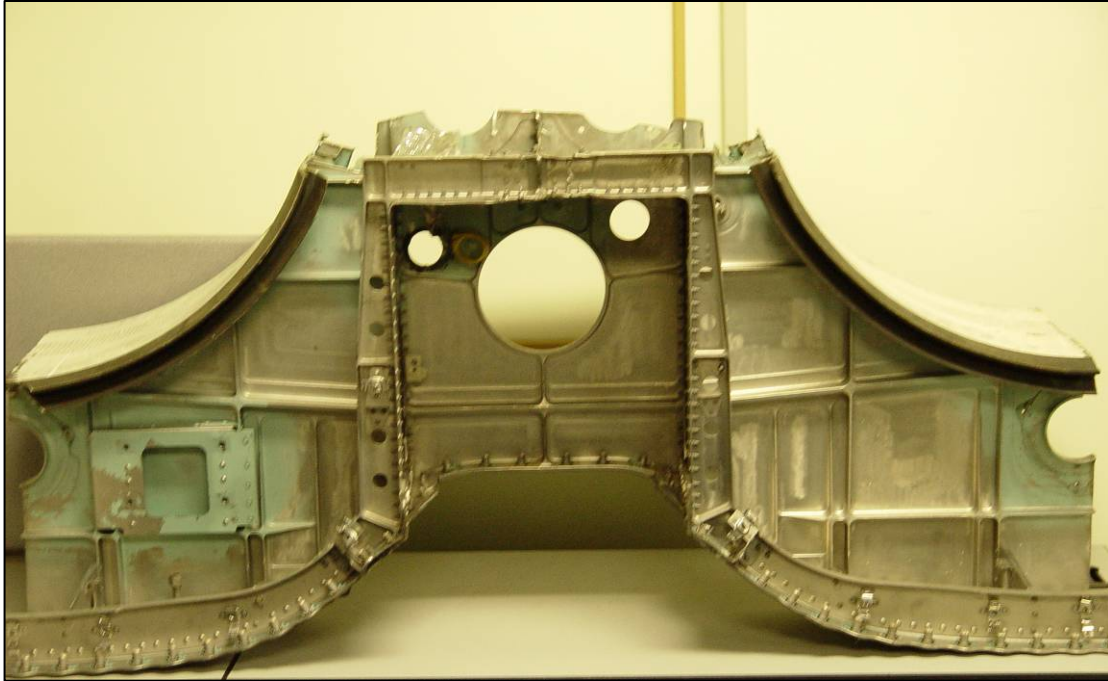

Figure 4.1: F-15 Bulkhead Section

After the bulkhead section arrived at the lab it became apparent that the group would be unable to re-create the complexity of the structure. It had also become clear that no work had been done with these types of sensors in complex structural environments. All of the published work that could be located had been accomplished on flat plates in controlled environments. This included work currently being done at AFIT by Capt. Steve Crider, whose research would serve as a starting point for our own efforts. The thesis group ultimately decided to begin our experiments as in all previous cases, with a flat plate. The goal, however, would be to progress to a more structurally complex system while verifying the capability of the METIS sensor.

All testing was conducted using a large rectangular plate of 7075-O aluminum measuring 21"x42"x1/4". During testing, the plate was supported by six small wooden blocks underneath each corner and at the middle of each of the long edges, in an attempt

to isolate the plate from any vibrations coming from the building, floor, or desk, and to allow for a more unconstrained response from the plate (Figure 4.2).

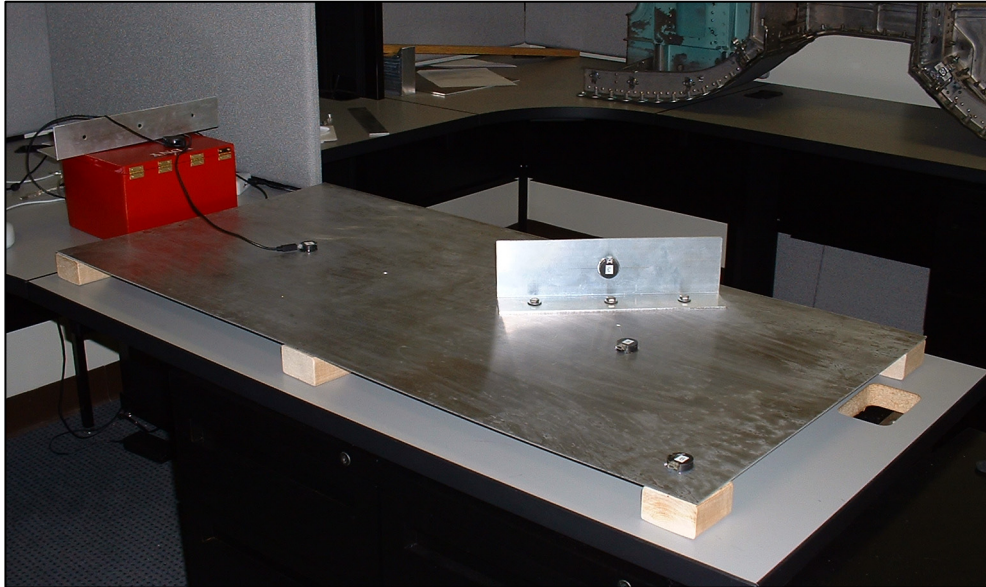

Figure 4.2: General setup of Test Plate

The plate of course was not perfectly isolated from vibration, nor was it removed at all from any ambient noise, but this was considered to be acceptable in two ways. First, all of the test results generated were with respect to the baseline state of the plate itself, so as long as the test setup was consistent and repeatable, the results should be free from major deviations. Secondly, the main objective of this series of tests was to establish the viability of this sensor package for real world use, and attempting to establish a laboratory like environment would defeat this ultimate goal. The second main objective of this test was to try and estimate the threshold damage size that could be detected with this system, which required at least some level of background noise to correlate with. Ultimately the question of background noise and sufficient baseline data would become major issues during interpretation of the actual test data.

Based on our knowledge of testing that had been accomplished or was currently ongoing, and our own goal of testing a more structurally complex system, the group devised our initial test matrix. The test progression would allow us to start in an area that was similar to Capt Crider's work, allowing the group the chance to verify our methods and results in comparison to his before moving into unknown territory. The original test matrix is shown in figure 4.3.

| | |
|---|--|
| <ul style="list-style-type: none"> 1. Baseline Plate 2. Single Block - Inside Reflection Boundary <ul style="list-style-type: none"> a. Different Orientations b. Different Sizes c. Different Shapes 3. Multiple Blocks - Inside Reflection Boundary <ul style="list-style-type: none"> d. Variable Spacing e. Stacked - Same Radial Line 4. Single Block - On Reflection Boundary <ul style="list-style-type: none"> f. Different Orientations g. Different Sizes h. Different Shapes 5. Single Block - Outside Reflection Boundary <ul style="list-style-type: none"> i. Different Orientations j. Different Sizes k. Different Shapes | <ul style="list-style-type: none"> 6. Actual Damage - Outside Reflection Boundary <ul style="list-style-type: none"> l. Scratch - Looking for Minimum Detectable Change m. Gouge - Vary Size Based on Previous Results n. Punch - Simulate Impact Damage <ul style="list-style-type: none"> i. Different Orientations ii. Different Locations iii. Different Radial Distances iv. Stacked - Same Radial Line v. Equal Radial Distance 7. Building Up Complexity of the Plate <ul style="list-style-type: none"> o. Drill out Damages Areas in Stacked Series p. Add Bolts/Stiffeners to Plate Parallel to Wave Path q. Drill out Damaged Areas to Allow for Perpendicular Stiffeners r. Add Bolts/Stiffeners to Plate Perpendicular to Wave Path 8. Add Actual Damage to Bolt Holes Under Stiffeners (Simulate Crack Initiation) |
|---|--|

Figure 4.3: Initial Pulse-Echo Test Matrix

As can be seen from the initial test matrix, a large amount of data was to be collected using the “simulated” damage method employed by Capt. Crider and others. Simulating damage to the plate offered several advantages, the most obvious of which was that the plate was not actually damaged and could be measured in its baseline state at the start of each test session. Another advantage was that many different combinations of damage could be explored, including the size, shape, and orientation of the damaged area, as well as any possible combination of damage types. A final and not insignificant advantage to simulated damage was that it allowed for operator training and familiarization with both the sensors capabilities and the software interface. For the purpose of damage detection using Lamb waves, simulating the damage condition can be accomplished in several ways. The basic principal is to create a highly localized change in the properties of the material, most notably, stiffness. This can be accomplished by the use of a clamp or vise, or even through the application of heat, but each of these methods carries a risk of permanently altering the plate. For our purposes, small aluminum or steel blocks (see figure 4.4) were placed on the surface of the test plate, using shear coupling gel to “attach” the two pieces. The addition of the block produces a localized change in stiffness of the plate which mimics an area of actual damage. The shear coupling gel allows the Lamb waves propagating through the structure to interact more effectively with the block, producing the best possible results in the data collected.

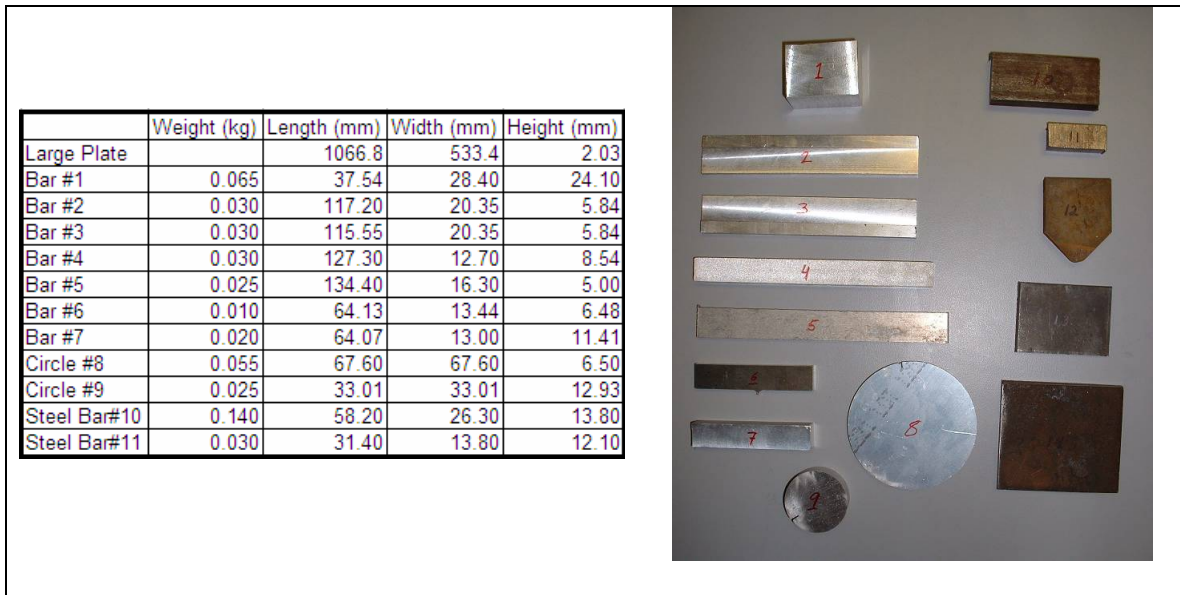

Figure 4.4: Blocks used for Simulated Damage Testing

An initial test period allowed the group time to learn the software interface, and collect data that we could correlate with the results produced by Capt. Crider. It also allowed the group to verify that the sensor was installed and operating correctly. During the initial learning curve we also explored the range of frequencies that the sensor was capable of outputting. Capt. Crider had identified 95 kHz as the optimum frequency for the plate he was testing, and our initial trials verified this was also the case for our plate. Since the group had long range plans to significantly alter the structural state of our test specimen, we decided to continue testing over a fairly large frequency range, ultimately utilizing a five frequency spread from 35 to 155 kHz. During this initial period the group also evaluated the software's averaging function. Taking multiple sets of data from the clean plate, using the various averaging settings, we compared the results and selected the lowest averaging setting (128 run average) above which a difference could no longer be discerned in the resulting data plots. One area the group did not explore during our testing was the actual waveform that the sensor generated. The software interface

allowed for changes to be made to the Lamb wave form produced by the sensor. Based on Capt. Crider's results, the default wave form was very effective for our basic plate, and felt that it would remain so as the structural complexity of the specimen was increased.

Once the initial learning curve was complete, a series of tests using blocks of various, size, shape and weight was conducted in an attempt to characterize the capability of the sensor with respect to the location, relative size and orientation of the "simulated" damage. Additionally, tests were conducted using multiple blocks in order to evaluate the ability of the sensor to provide distinct returns for more than one damaged area. After completing "simulated" damage testing, we proceeded to actually damaging the plate. There was obviously less flexibility when it came to actual damage, but the basic plan was to try and start with the smallest damage possible, and then to work up in size, with some changes in orientation and location to see how the results varied. The plan for actual damage included several locations which would eventually be drilled out, and were spaced to allow for the future addition of other structural members to the plate. This would be done in an attempt to build up the complexity of the overall structural element and increase the density of the baseline signal from which an area of new damage would have to be detected.

Initial testing was conducted using a first generation Pulse-Echo sensor which allowed us to mimic testing already accomplished by Capt. Crider. Subsequent testing was accomplished using second generation Pitch-Catch sensors, which are also capable of Pulse-Echo operation. The software interface required to operate these sensors was provided by the METIS Corporation, and can best be described as an "in house" or

“prototype” system, being used by the company to develop the sensor package and define the user interface. The programs produced data files in either Excel or Comma Separated Value (.csv) format depending on if the “demo” or “test” version of the software was being utilized. Data reduction was accomplished in both Matlab, and Excel. For “simulated” damage testing, a baseline data set was recorded at the start of each day. For actual damage testing, a minimum of 2 baseline data sets were recorded between each successive damage addition, with 3 sets of data being the normal process. Digital photographs were taken to record the simulated or actual damage condition of each test run. Pre and post test pictures were taken of the simulated damage test setup to document the condition of the shear gel contact area under each block.

4.5 Test Results: First Generation METIS Sensor

Initial testing was accomplished using one of the first generation Pulse-Echo type sensors which was already being utilized in other experiments and was immediately available. These “first-generation” sensors are only capable of Pulse-Echo operations and are somewhat limited in their output capability. The advertised output for the standard METIS sensor is 20 volts peak to peak, while the sensors being used at AFIT had only a 6 volt peak to peak capacity. This limitation was not expected to be an issue since the sensors were already in use and seemed to be performing fine. The large plate was exactly rectangular in shape. The long edge was exactly twice as long as the short edge, essentially creating two square surfaces. The sensor was applied to the center of one of the square ends of the plate such that the sensor was equal-distance from 3 edges of the plate (see figure 4.5). This created a situation approximately equivalent to the large square plate being tested by Capt. Crider. Previous experience had shown that any

discontinuity in the plate, especially the edges, would produce strong reflections of the Lamb wave back to the sensor. On the square plate, these returns would all reach the sensor at the same time, producing a very predictable and regular data pattern that helped in analyzing subsequent information. In addition, the symmetric shape of the square plate actually caused a reduction in the number of reflections since any wave that didn't hit the edge of the plate perpendicularly was met by a similar reflection from an adjacent plate edge, and cancelled out. Although not as efficient as the purely square plate, the rectangular plate produced the same type of distinct reflection pattern. As mentioned previously, damage, or more precisely, a change in the material property of the plate, produced two unique phenomenon that were observed in the sensor data. The first was a reflection of the lamb wave off of the damaged area, which shows up in the data plot as change outside of the normal reflection pattern. The second change was caused by an absorption of energy from the Lamb wave as it passed by the damaged area twice, once as the wave passed the site outbound from the sensor, and once again on the way back to the sensor after being reflected from the edge of the plate. This effect was observed as both a change in amplitude in the normal reflection pattern, and as a shift in the timing of the reflection pattern, due to the attenuation of the frequency of the original signal. Of these two effects, the change in amplitude appeared to be more noticeable, possibly due to the relative size of the damage with respect to the rest of the plate. These phenomenon obviously continued to occur as the wave bounced back and forth multiple times from the edges of the plate and past the sensor, but we had concentrated our analysis to the primary reflection from the damaged area, and the primary reflection from the three closest edges. These reflections were the strongest and cleanest returns. For the

purposes of testing, the plate was divided into two areas, separated by what is referred to as the “reflection boundary” (see figure 4.5). This boundary was defined by a circle, centered on the sensor that extends to the 3 nearest edges of the plate.

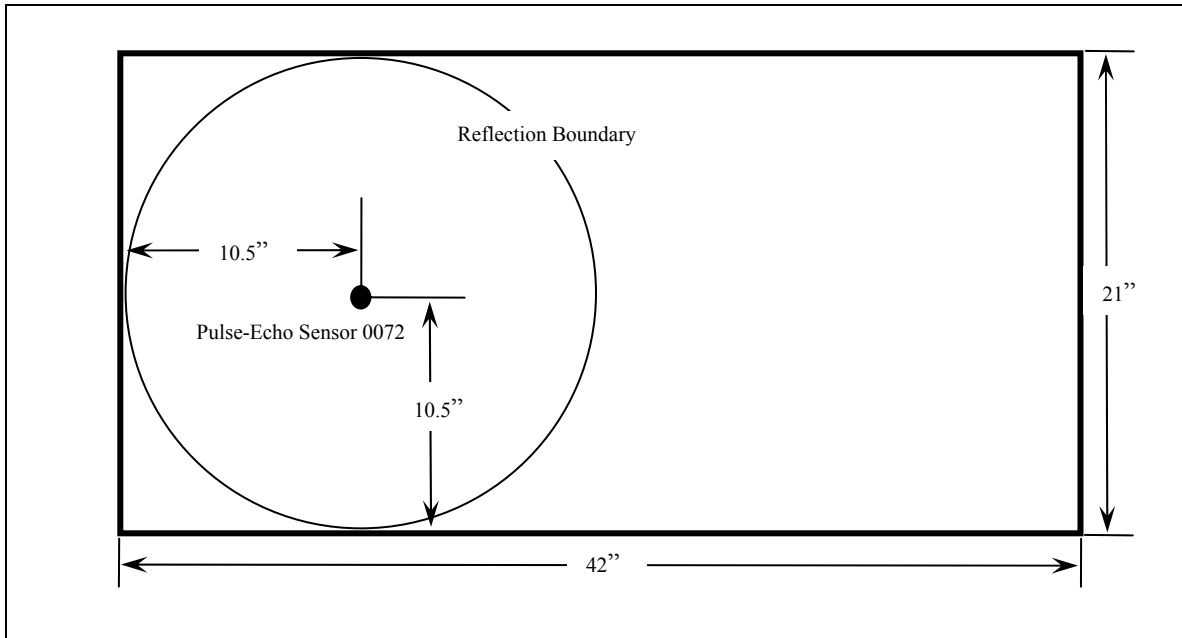

Figure 4.5: Large Plate with First Generation Sensor Installed

Damage that occurs inside the reflection boundary will produce a reflection that should be observed before the first primary edge returns, and should produce attenuation effects within the primary edge return. Damage outside the reflection boundary should have no observable effect on the primary edge returns (or the secondary edge returns depending on the location of the damage). This result was important because it gave us a clue as to whether damage could be identified in a return signal from a more complicated structure, with multiple sources of reflections and interference. The final case occurs when the damage lies on the reflection boundary (or some whole number multiple of the reflection boundary distance) which will only generate a change in the edge returns. The group’s initial test runs involved taking multiple sets of baseline data with the clean plate,

with several objectives. The first task was to compare the different baseline results in order to establish the level of “background” noise that we could expect from run to run. This result was especially important since the primary mechanism for damage detection using the METIS sensor is the continuous comparison of data with previously existing baselines. The effectiveness of the sensor was dependent on the groups’ ability to separate the “damage” return from the “noise” inherent to the system. Our analysis of the initial simulated damage tests were accomplished using a program written by Capt. Crider. This data reduction program not only plotted the sensor data, but also calculated the expected locations for primary edge reflections and secondary reflections generated by the damaged area. This was accomplished by inputting the exact dimensions and material properties of the plate, the location of the damaged area and the frequency of the Lamb wave. The initial results using this program were not encouraging. The locations of the expected returns did not coincide with the predictions generated by the program, and the magnitude of the returns produced by the damage were significantly less than expected based on Capt. Crider’s test data. Even though we continued to progress through the test matrix we spent a great deal of time trying to explain the unexpected results we were seeing. Eventually we suspended testing and tried to focus on understanding the results. The groups’ initial assessment of the situation was that the physical size and/or shape of the plate was affecting the results. The plate we were using was substantially larger than the one used by Capt. Crider, possibly masking the returns produced by the small aluminum blocks being used to simulate damage. The second area of concern had to do with the shape of the plate. It became apparent that the plate was not perfectly flat, and would actually sag along its long axis when sitting on the wooden

blocks. This effect was first seen in some of the post-test pictures taken of the damage blocks after they had been removed (see figure 4.6).



Figure 4.6: Post-Test Pictures Showing Partial Contact of Damage Blocks

The pattern of the shear gel on the plate gave the group a clear indication that the blocks were not making uniform contact with the plate, especially when they were placed along the center axis of the plate. After considering the problem, the group decided to address the problem by modifying the damage position. To address the contact issue, the group conducted a series of tests at different locations and orientations on the plate to minimize the effects of the sagging plate. In addition, a selection of steel blocks was obtained in order to increase the magnitude of the simulated damage by simply increasing the magnitude of the local change in stiffness of the plate. Although both of these changes produced the desired effects, the data plots generated using Capt. Crider's program did not show any significant improvement. At this point, the group had been resigned to the possibility that the first generation sensor simply did not have enough output capability to "see" damage in this large plate. The next step was to begin actually damaging the plate. Due to the groups' suspicions that the sensor might lack the output

necessary for this plate, the group elected to move our first damage location inside the reflection boundary in order to increase the chances of success. A total of four successively larger areas of damage were produced at the same location on the plate (see figure 4.7). Initial reviews of the data showed that the actual damage produced an even smaller return than the simulated damage blocks. In many cases, the group was unable to determine that any change had taken place to the plate at all. At this point the group was convinced that the sensor simply was not capable of producing a strong enough wave to illuminate the damage in the plate. More precisely, the changes in the wave produced by the damage in the plate were so small, relative to the original size of the wave, that we were unable to distinguish them from the background noise coming through the sensor. This had always been one of the biggest unknowns with regards to the usefulness of this sensor technology in an operational environment where background noise is a fact of life. To present both sides of the story, it must be noted that we made no attempt to control the background noise, nor did we make any attempt to try and filter the data to account for background noise. There are in fact, many methods in use which can effectively filter sensor data and highlight specific data ranges for analysis. Our overarching concept, however, was to maintain the simplest methods possible, and the highest level of data presentation in an attempt to establish the absolute capability of the sensor package.

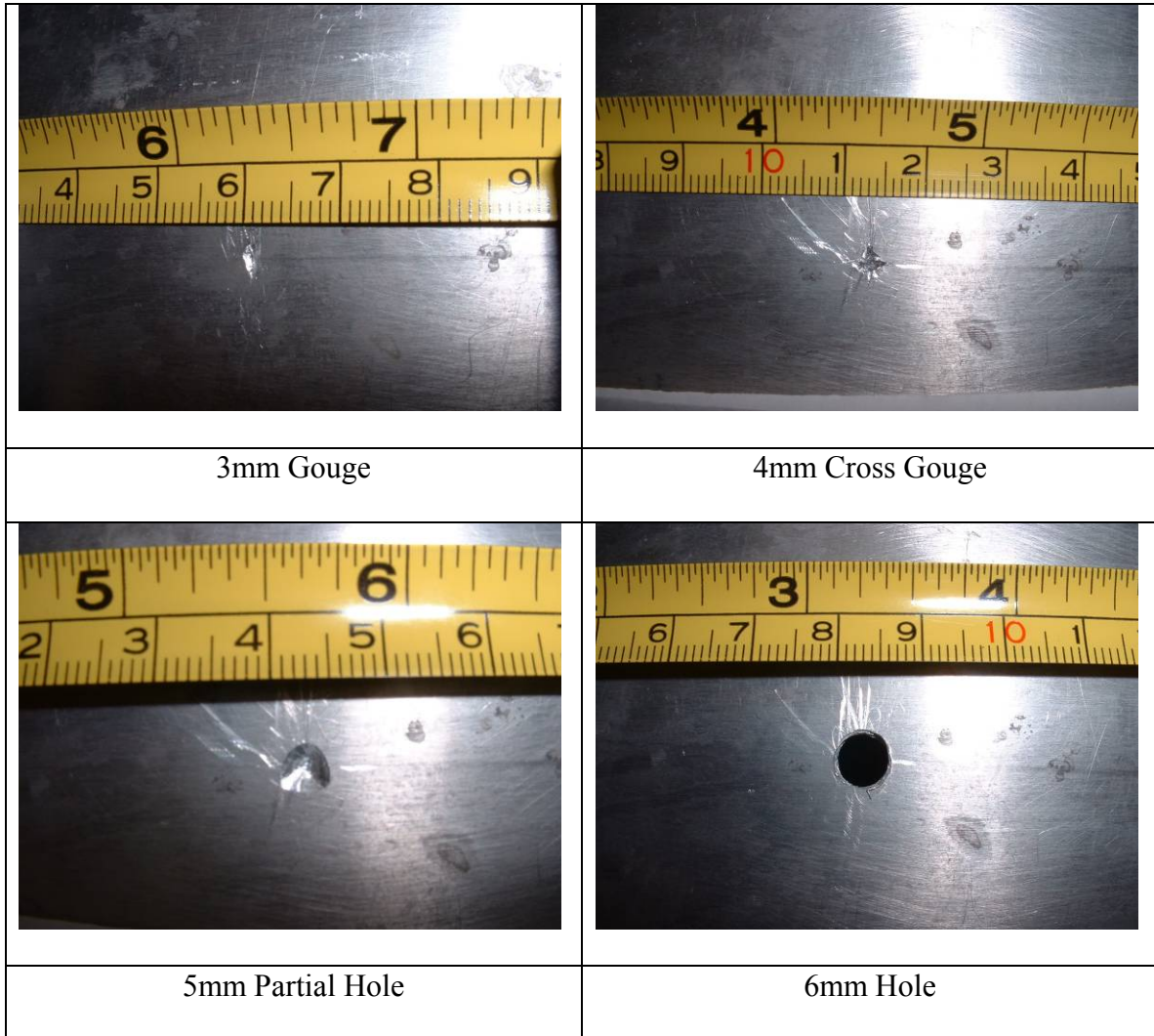

Figure 4.7: Actual Damage for initial Pulse-Echo Sensor Testing

At this point in the process the group had concluded that the first generation sensor was not capable enough for the task at hand, and that we would need to wait for the second generation sensors which had been ordered from MDC. While the group waited for the next batch of sensors to arrive we began to experiment with a different data reduction process, utilizing simple spreadsheet calculations and plotting. Much to our surprise we came up with much different results for the simulated damage testing then we had been

seeing with Capt. Crider’s Matlab program. For the most part, the simulated damage tests were almost universally positive, meaning that we could see an obvious change to the plate in every case, and usually at every frequency. This change in results did not, however, extend to the actual damage cases, which still showed no clear indications of damage in the data. A summary table of the test results is presented in figure 4.8.

| Pulse Echo Test Results: Sensor 0072 | 35kHz | 65kHz | 95kHz | 125kHz | 155kHz |
|--|-------|-------|-------|--------|--------|
| 08 Nov: Block 1, 6", 0° | Y | Y | Y | Y | Y |
| 08 Nov: Block 2, 6", 0° | Y | Y | Y | Y | Y |
| 10 Nov: Block 1, 16", 0° | ? | Y | Y | Y | Y |
| 10 Nov: Block 2, 6", 90° | Y | Y | Y | Y | Y |
| 10 Nov: Block 2, 6", 90°, Angled | Y | Y | Y | Y | Y |
| 10 Nov: Block 2, 10.5", 0° | Y | Y | Y | Y | Y |
| 10 Nov: Block 2, 6", 0°, Short Edge | ? | Y | Y | Y | Y |
| 10 Nov: Block 8: 6" 0° | ? | Y | Y | Y | Y |
| 10 Nov: Block 2 6", 0°, Block 1 16", 0° | Y | Y | Y | Y | Y |
| 10 Nov: Block 2 6", 90°, Block 1 16", 0° | Y | Y | Y | Y | Y |
| 16 Nov: Block 1, 165mm, 0° | ? | ? | Y | ? | Y |
| 16 Nov: Block 2, 165mm, 0° | Y | Y | Y | Y | Y |
| 16 Nov: Block 2, 433mm, 0° | Y | Y | Y | Y | Y |
| 16 Nov: Block 1, 165mm, 0°, Block 2, 433mm, 0° | ? | ? | Y | Y | Y |
| 21 Nov: Block 2, 165mm, 0° | n/a | n/a | Y | Y | Y |
| 28 Nov: Block 10, 165mm, 0° | n/a | n/a | Y | Y | Y |
| 28 Nov: Block 10, 165mm, 90° | n/a | n/a | Y | Y | Y |
| 30 Nov: Block 10, 165mm, 180° | n/a | n/a | Y | Y | Y |
| 13 Dec: Damage One, 3mm Gouge | N | N | N | ? | ? |
| 14 Dec: Damage One | N | Y | ? | ? | ? |
| 14 Dec: Damage Two, 4mm Cross Gouge | N | N | N | N | N |
| 15 Dec: Damage Two | ? | N | N | N | N |
| 15 Dec: Damage Three, 5mm Partial Hole | N | N | N | N | N |
| 15 Dec: Damage Four, 6mm Hole | N | ? | ? | Y | Y |

■ Damage Indicated
 ■ No Determination Possible
 ■ No Damage Indicated

Figure 4.8: Sensor 0072 Pulse-Echo Test Results

These new results forced the group to reconsider some of the conclusions we had made up to this point, and also provided some new information with respect to the methods being used. The first, most obvious conclusion was that we had somehow misused the software created by Capt. Crider in the processing of our data. After some consideration it was concluded that we had not provided accurate enough information with respect to the dimensions and material properties of our test plate to allow the program to function properly. This conclusion only explained why the predictive models

in the program were inaccurate, and did not account for the reduction in magnitude seen between our data and Capt. Crider's. After comparing the results from the two different data processing routines we determined that the magnitude of the results was consistent, and that our original assumption that the plate was simply too large for the output of the sensor was accurate. The next conclusion we drew from the test results was that our simulated damage testing was not a good indicator of sensor performance with respect to actual damage detection. The signature produced by the blocks was obviously different in terms of magnitude and definition compared to the actual damage. This is not to say that simulated damage testing was not useful, only that the method we used did not produce results that were comparable to actual damage. The final conclusion that we made was actually an affirmation of one of our earlier results. The first generation METIS sensor does not have that capacity to detect damage in the plate we were testing. Even as we increased the size of the damaged area, the sensor returns did not pick up the change. It is entirely possible that this sensor could be used in a different location, on a smaller specimen, but it was insufficient for our test setup.

4.6 Test Results: Second Generation METIS Sensor

The second generation METIS sensors are outwardly no different from the first generation models. The difference between the two stems from the fact that the second generation model can operate in either Pitch-Catch or Pulse Echo mode, and is capable of its full advertised output of 20 volts peak to peak. The group's first batch of new sensors was delayed after MDC discovered a flaw in the first batch produced. While waiting for the sensors to arrive we contemplated both our planned test matrix and the sensor placement we would use. After considering several options for testing, including a new

plate, we chose to continue testing with our original plate, adding a total of three new sensors equally spaced as shown in figure 4.9. The location of the new sensors was chosen for two primary reasons.

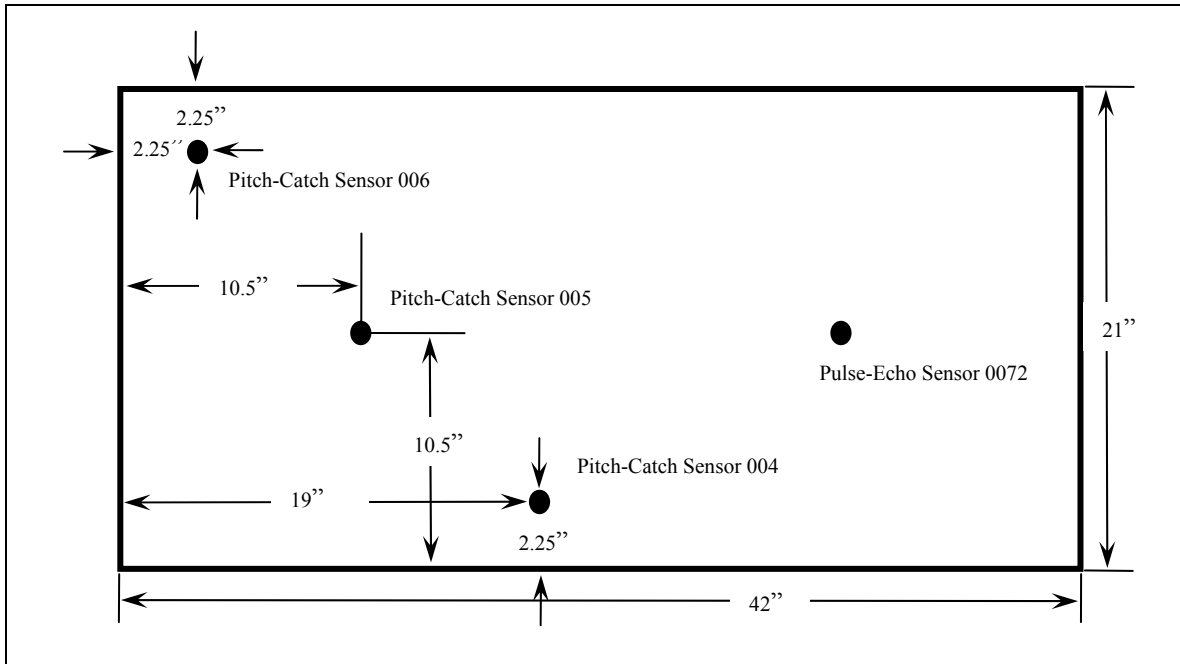

Figure 4.9: Large Plate with All Sensors Installed

First, using the same plate allowed for potential comparison of both the first and second generation of sensors using the same damage conditions. While this was in fact never accomplished, the potential was seen as a benefit towards using the same plate.

Secondly, the symmetric, in-line arrangement of the three sensors was conceived to allow for a “back-up” arrangement in case of some unexpected results. The path between the center sensor and the two outside sensors was essentially identical. Even though the orientation of the outside sensors with respect to the edges of the plate was different, the initial pulse received by the outside sensors was identical. Previous research had shown that with this arrangement, baseline data between one set of sensors can in fact be substituted for another with no change in results. Our reasoning behind this arrangement

had more to do with the potential for damaging the plate in such a way that we could not continue testing and needing a second location to continue. Once again, we never in fact needed the secondary test area, but the potential benefit influenced our final decision on sensor location.

Our primary test location was between sensors 005 and 004. Most tests were conducted using sensor 005 as the actuator and sensor 004 as the recorder. The software interface provided with the sensors only supported two sensors during any given test. This turns out to a fairly significant limitation to the overall concept of operations since there are many scenarios where the same signal recorded at multiple sensor locations can provide information with respect to the location of the damaged area. Another operating constraint to the software interface was the speed at which the tests were conducted. The software could be set up to run a sweep of all the selected frequencies. Using the 128 average setting that we had selected, one run would take approximately one hour to complete. The simple fact of not having enough time available to complete multiple runs kept us from taking any significant amount of data using sensor 004 as the actuator, and prevented us from using sensor 006 at all. Based on the results of earlier testing we modified our test matrix for Pitch-Catch (see figure 4.10).

The group's plan was to conduct minimal simulated damage testing in order to verify that the sensors were installed and functioning properly. This would also give the group enough experience with the software interface to conduct further testing. Damage to the plate was initiated at the center point between sensors 004 and 005.

1. Baseline Plate
2. Single Block - Between Sensors
 - a. Different Sizes/Weights
 - b. Offset from Direct Line
3. Actual Damage - On a Perpendicular Line Between the Sensors
 - a. Gouge - Looking for Minimum Detectable Damage - Vary Size Based on Previous Results
 - b. Punch - Simulate Impact Damage
 - c. Hole - Drill out Damaged Areas using increasingly larger bits
4. Building Up Complexity of the Plate
 - a. Drill out Damages Areas in Stacked Series
 - b. Add Stiffener to Plate Between Sensors
5. Actual Damage - Plate with Stiffener
 - a. Damage Plate Away from Stiffener
 - b. Damage Plate Under Stiffener - Simulate Crack Initiating at Bolt Hole

Figure 4.10: Initial Pitch-Catch Test Matrix

Subsequent damage was added to the plate at two locations offset from the line between sensors 004 and 005. The resulting damage locations formed a line perpendicular to the line intersecting sensors 004 and 005. Several types of damage were added to the plate. A chisel was used to gouge the surface of the plate, providing the closest analogy to a crack that we had the means to inflict. Impact damage was also simulated by means of a punch (Figure 4.11). Finally, the damaged areas were drilled out using a 1/16" drill bit, followed by a 1/4" drill bit. Once these three locations were drilled out, a stiffener was added to the plate to increase the structural complexity of the system.

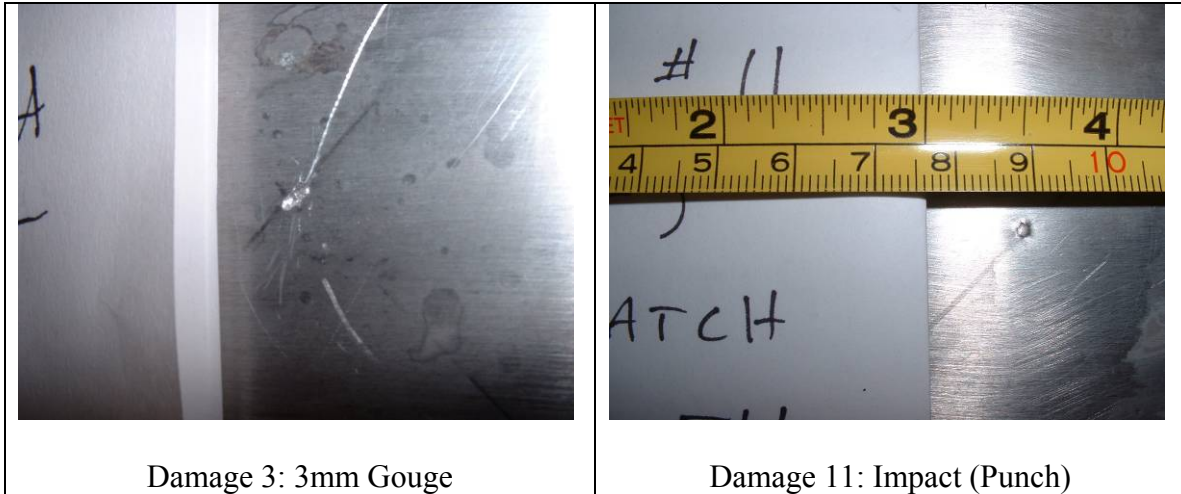

Figure 4.11: Damaged Areas

At this point, additional damage was added to the plate between the stiffener and sensor 005, and under the stiffener, originating from the center hole location. This final configuration would provide the answer to the question of whether or not the sensors had the capability to detect damage in a more structurally complex environment (see figure 4.12).



Figure 4.12: Damage Testing w/ Stiffener Installed

A summary of Pitch-Catch test results is presented in figure 4.13. Results for the limited simulated damage testing all showed favorable results, much like the first generation

Pulse-Echo sensor. Actual damage testing showed generally better results with the new sensor, but the results were inconsistent. Not all damage types were clearly indicated in the data, nor was there any clear preference with respect to the frequency. One surprising result occurred with the stiffener installed. In almost every case, the damaged area was clearly detected by the sensor when the stiffener was in place. This led to an obvious conclusion that the overall effectiveness of the sensor system is dependent on the properties of the system as a whole. Common sense tends to support this conclusion, but the results provided a dramatic illustration of this effect.

| Pitch-Catch Test Results Sensors 005/004 | 35kHz | 65kHz | 95kHz | 125kHz | 155kHz |
|--|-------|-------|-------|--------|--------|
| 8 Jan: Block 10, Centered | Y | Y | Y | ? | Y |
| 10 Jan: Block 7, Short end, Centered | Y | Y | Y | Y | ? |
| 16 Jan: Block 7, Short end, 77mm Offset | Y | Y | Y | Y | N |
| 27 Jan: Damage 3, 5mm gouge | Y | Y | N | N | N |
| 29 Jan: Damage 3, 5mm gouge | Y | ? | N | N | N |
| 29 Jan: Damage 4, Punch | Y | ? | ? | Y | ? |
| 30 Jan: Damage 4, Punch | N | N | ? | ? | N |
| 30 Jan: Damage 5, 5mm cross gouge | ? | Y | Y | Y | ? |
| 30 Jan: Damage 5, Run 2, 5mm cross gouge | Y | Y | Y | Y | ? |
| 31 Jan: Damage 6, 1/16" hole | N | ? | N | ? | ? |
| 31 Jan: Damage 6, 1/16" hole, Run 2 | N | N | N | Y | N |
| 1 Feb: Damage 6, 1/16" hole | Y | N | N | N | N |
| 1 Feb: Damage 7, 1/4" hole | N | Y | Y | Y | Y |
| 1 Feb: Damage 7, Run 2, 1/4" hole | N | Y | Y | Y | Y |
| 2 Feb: Damage 7, 1/4" hole | ? | Y | Y | Y | Y |
| 2 Feb: Damage 8, 5mm gouge, 100mm offset | N | ? | ? | ? | ? |
| 2 Feb: Damage 8, Run 2, 5mm gouge, 100mm offset | N | ? | ? | ? | ? |
| 3 Feb: Damage 8, 5mm gouge, 100mm offset | N | ? | Y | Y | ? |
| 3 Feb: Damage 9, 1/16" hole, 100mm offset | N | ? | Y | Y | Y |
| 3 Feb: Damage 9, Run 2, 1/16" hole, 100mm offset | N | ? | Y | Y | ? |
| 3 Feb: Damage 10, 1/4" hole, 100mm offset | N | Y | Y | Y | ? |
| 4 Feb: Damage 10, 1/4" hole, 100mm offset | N | Y | Y | Y | ? |
| 4 Feb: Damage 11, Punch, 100mm offset | N | ? | ? | N | N |
| 4 Feb: Damage 11, Run 2, Punch, 100mm offset | N | ? | N | N | N |
| 5 Feb: Damage 11, Punch, 100mm offset | N | ? | ? | N | N |
| 5 Feb: Damage 12, 1/4" hole, 100mm offset | N | Y | Y | Y | Y |
| 6 Feb: Damage 12, 1/4" hole, 100mm offset | N | Y | Y | Y | Y |
| 6 Feb: Damage 12 with angle | Y | Y | Y | Y | Y |
| 7 Feb: Damage 12 with angle | Y | Y | Y | Y | Y |
| 8 Feb: Damage 12 with angle | Y | Y | Y | Y | Y |
| 8 Feb: Damage 13 with angle, 5mm gouge, 65mm / 5 | Y | Y | ? | ? | ? |
| 8 Feb: Damage 13 with angle, Run 2, | Y | Y | ? | ? | ? |
| 9 Feb: Damage 13, 5mm gouge, 65mm from 5 | N | ? | ? | Y | ? |
| 9 Feb: Damage 13 with angle, 5mm gouge, 65mm / 5 | Y | Y | Y | Y | Y |
| 10 Feb: Damage 13 with angle, 5mm gouge, 65mm / 5 | Y | Y | Y | Y | Y |
| 11 Feb: Damage 13, 5mm gouge, 65mm from 5 | Y | Y | Y | ? | ? |
| 12 Feb: Damage 13, 5mm gouge, 65mm from 5 | Y | ? | ? | ? | N |
| 12 Feb: Damage 14, 2mm cut from center hole | Y | Y | Y | Y | Y |
| 12 Feb: Damage 14, Run 2, 2mm cut from center hole | Y | Y | Y | Y | Y |
| 15 Feb: Damage 14 with angle, 2mm cut from center | Y | Y | Y | Y | Y |
| 16 Feb: Damage 14 with angle, 2mm cut from center | Y | Y | Y | Y | Y |
| 19 Feb: Damage 14 with angle, 2mm cut from center | Y | Y | Y | Y | Y |

■ Damage Indicated
■ No Determination Possible
■ No Damage Indicated

Figure 4.13: Pitch-Catch Test Results

4.7 Conclusions

Although somewhat limited in scope the testing completed by this thesis group does allow for several important conclusions with respect to damage detection using Lamb wave technology, and the METIS sensor package in particular. The first and most obvious conclusion is that there is potential for this technology and for the METIS sensor to be used in structurally complex environments. This conclusion will require further validation on ever increasingly complex test specimens (see figure 4.14)

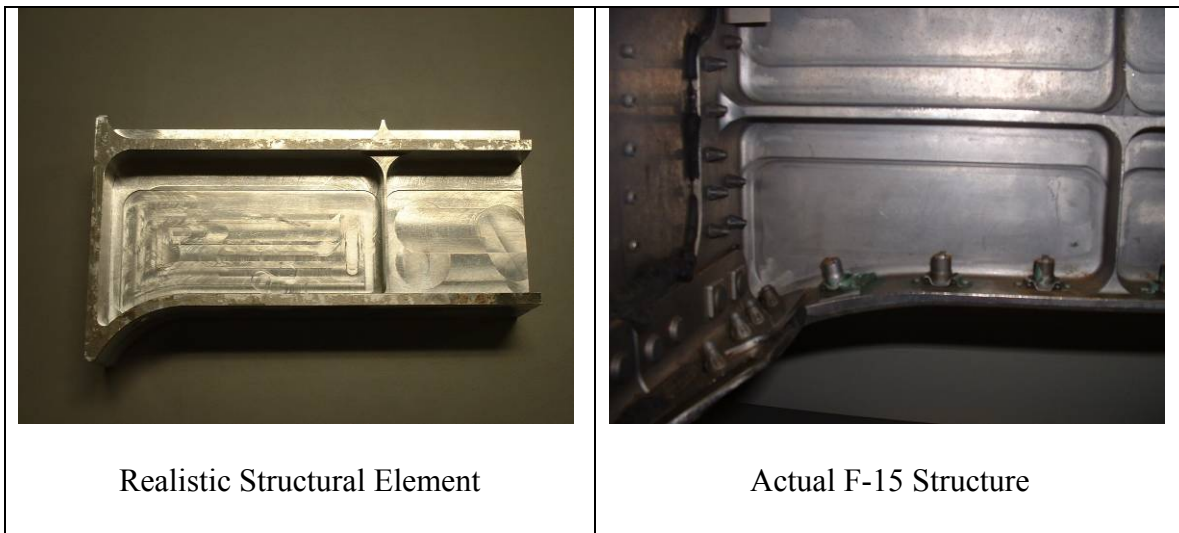

Figure 4.14: Possible Specimens for Future Sensor Testing

The next conclusion suggested by the results is that the simulated damage methods employed by this thesis group do not provide a good indication of sensor performance with respect to actual damage. The most likely reason for this is that the magnitude of change induced by the blocks is far greater than the magnitude of change produced by the actual damage inflicted. This is not to say that there is no good simulated damage method to be found, but the one used for this thesis was not viable. The result with the most potential for affecting future efforts is the fact that overall properties of the test specimen affect the performance of the sensor. Once again, this makes intuitive sense but the reality of the situation is much more complex. This result calls into question the methodology of starting simple and building up the structural complexity of the test specimen. It is entirely possible that the sensor locations, frequencies and possibly even the wave forms that worked in the initial element will not be capable of working in the altered element. The potential result is that a great deal more effort is spent constructing the test specimen to more closely resemble the actual structure in question. Only then can the sensor location, operating frequencies, and wave forms be optimized for the real environment. A final area of consideration has to do with data processing and the treatment of background noise. Since damage detection using Lamb waves is based on comparative data analysis, significant work must be accomplished to gather and correlate baseline data from the system to use for comparison. Our research has shown that baseline data, while fairly consistent, is subject to many variables, and can easily overwhelm the desired damage signatures in the data. Our research did not employ any kind of filtering or long term data averaging. Data analysis was conducted using an average of the previous baseline data (2 or 3 separate

data sets). Multiple runs of the same test condition were conducted and compared. For the most part, the results of these “identical” runs were consistent, but not in every case, especially if the runs were conducted on different days. Obviously the area of data filtering and rules for conducting the actual data comparisons needs to be explored more fully. In the end, this thesis group feels as if we have advanced the understanding of the capability of this sensor package, as well as identified several areas which require further study.

V. Recommendations for Further Research and Conclusion

This chapter summarizes the conclusions of the group regarding the architectures and processes developed. It also provides suggestions for avenues of further research in a variety of areas.

5.1 Suggestions For Further Research With METIS Sensor

Although the thesis group was able to test two generations of sensors on a single test specimen in a multitude of ways, the action of actually damaging the specimen limits the number of tests that can be performed on a single specimen. Further testing needs to be conducted on additional specimens in order to refine the capabilities of the METIS sensors. Suggestions for additional testing include different size plates, different thicknesses, more complex geometries, additional frequencies, different amplitudes, different materials, and damage at different locations. Additional research could be undertaken in order to determine the minimum size damage that can be detected. Studies need to be performed that examine whether different frequencies are optimal for different types of damage, or different materials. Ideally, one optimal frequency could be used for each structural area on an aircraft instead of having to do frequency sweeps like the thesis group. The capabilities of the METIS sensors were limited during this thesis to the use of two nodes in the pitch-catch mode and further research can be explored to expand the capabilities to multiple nodes where potentially a network of nodes can be used. Additionally, the size and wiring of METIS sensors could make their use in an actual aircraft complicated, therefore research can be done to reduce the disk size and explore the use of wireless technology in transmitting data.

5.2 Suggestions For Further Research With Software

The thesis group relied on rather basic methods of data manipulation and filtering in order to analyze the data. A very wide avenue that needs to be explored further for structural health monitoring is the software aspect. The thesis group found that one of the most significant challenges in operating the ISHMS was the sheer magnitude and complexity of data. The thesis group used Microsoft Excel and some basic MatLab code to analyze the data using simple comparative analysis. There is tremendous potential in using software to accomplish data manipulation and filtering automatically. Computer programs that can filter out the important aspects of data and automatically compare them to other programs would be vital to successfully monitoring the structural health of an aircraft fleet. These programs could potentially make it much simpler for the engineer to make recommendations.

5.3 Additional Suggestions For Further Research

Finally, although the thesis group chose to experiment with the METIS sensor, there are many other technologies that exist that could monitor structural health. Another approach can be to select an entirely different technology to study from among those currently available or a new emerging technology, or even select several different technologies to be studied and packaged together that can provide multiple capabilities. The generic process created by the thesis group can then be used as a guideline to integrate these technologies into an aircraft. Finally, another emerging area in structural health is the desire for real-time structural health monitoring. As technology improves, research can be done into an ISHMS that can provide real time data or warning system inside cockpit for the crew.

5.4 Conclusion

From the beginning, the primary goal of the thesis group was to create a process to develop a generic structural health monitoring system. This process would enable the user to integrate any current or past technology into a variety of applications. The process would be flexible enough to account for a variety of sensor systems and structural areas. Through the development of an actual structural health monitoring system, the thesis group was able to validate significant steps of the process. The development of the structural health monitoring system shows that system requirements can be translated into an operational system with damage detection capability. In addition, the thesis group proved the potential of the METIS sensor package for structural health monitoring applications. Although the thesis group only had the time and resources to run a limited test regime, the group concluded that the technology is applicable for structural problems and that further research should be conducted to improve the knowledge base for the METIS sensors. With additional time and resources, the thesis group is confident that the METIS sensors, applicable software and data processing resources could be integrated into a functional structural health monitoring system able to meet the user needs.

Appendix A. Integrated Data Dictionary (AV-2)

OPERATIONAL ACTIVITIES:

Operational Activity: Analyze Data

Glossary Text: Data Analysis includes all activities related to detailed analysis of the processed data. This includes drawing conclusions and recommendations from the processed data relevant to a specific structural problem.

Operational Activity: Analyze Reports

Glossary Text: Consists of an overall analysis of mission, aircraft and fleet reports to ensure data integrity.

Operational Activity: Collect Data

Glossary Text: Consists of the sensor performing the structural monitoring test and collecting the data in raw form

Operational Activity: Collect / Store Data

Glossary Text: Data collection includes utilizing sensors to record raw data from sample of interest and storing it.

Operational Activity: Compile Flight Data

Glossary Text: Filter out bad data and correlate raw data with mission parameters

Operational Activity: Define ISHM System Requirements

Glossary Text: Consists of all actions taken to define the system requirements. May include Operational, Maintenance, Sensor and Data requirements.

Operational Activity: Design Data Collection Device

Glossary Text: Design the ISHM Data Collection Device to meet the Data Collection Requirements.

Operational Activity: Design Data Processing Software

Glossary Text: Design the ISHM Data Processing Software to meet the Data Collection Requirements.

Operational Activity: Design Sensors

Glossary Text: Design ISHM Sensors to meet the sensor requirements.

Operational Activity: Design ISHM System

Glossary Text: Consists of all actions taken to design and acquire the system. May include sensors, data collection device, software and engineers.

Operational Activity: Determine Accessibility

Glossary Text: Ease of access to the structural health monitoring system components.

Operational Activity: Determine Analysis Requirements

Glossary Text: Determine the necessary engineering skills and needs to interpret the data into usable recommendations.

Operational Activity: Determine Concept of Operations

Glossary Text: Determine the concept of operation for the ISHM System. Will include how often sensors take readings, how often data is collected and analyzed, and procedures for taking maintenance action.

Operational Activity: Determine Data Requirements

Glossary Text: Determine the requirements for the data collection and processing components of the ISHM System.

Operational Activity: Determine Durability

Glossary Text: The capabilities of the structural health monitoring system to sustain damage and severe environments.

Operational Activity: Determine Maintainability

Glossary Text: The ease in which the system is repaired.

Operational Activity: Determine Maintenance Requirements

Glossary Text: Determine the requirements for the maintenance of the ISHM System. May include, maintainability, reliability, availability, accessibility, etc.

Operational Activity: Determine Sensor Locations

Glossary Text: Determine the location of sensors based on crack history, critical locations, or engineer recommendation.

Operational Activity: Determine Sensor Properties

Glossary Text: Determine the necessary sensor properties such as temperature range, accuracy, frequency, size, sampling rate, etc.

Operational Activity: Determine Sensor Quantity

Glossary Text: Determine the number of sensors required to cover an area of interest.

Operational Activity: Determine Size Requirements

Glossary Text: Determine the size requirements of the ISHM System.

Operational Activity: Determine Monitoring Requirements

Glossary Text: Determine the requirements for the sensor components of the ISHM System.

Operational Activity: Determine Operational Requirements

Glossary Text: Determine the operational requirements for the ISHM System. May include operational concept, environmental factors, etc.

Operational Activity: Determine Processing Requirements

Glossary Text: Determine the necessary data processing requirements. Includes level of automation, output format, etc.

Operational Activity: Determine Reliability

Glossary Text: The probability that a system will malfunction in a specified period of time.

Operational Activity: Determine Storage Requirements

Glossary Text: Determine the necessary amount of data storage for applicable information.

Operational Activity: Determine System Health Performance

Glossary Text: Consists of actions taken to determine the health of the ISHM System. These may be in the form of self-diagnostics or inspections

Operational Activity: Determine Temperature Requirements

Glossary Text: Determine the temperature requirements of the ISHM System.

Operational Activity: Determine Vibration Requirements

Glossary Text: Determine the vibration requirements of the ISHM System.

Operational Activity: Generate A/C Maintenance Actions

Glossary Text: Consists of maintenance actions to repair or replace damage structure.

Operational Activity: Generate Flight Restrictions

Glossary Text: Consists of adding or changing flight restrictions to prevent further or additional structural damage.

Operational Activity: Generate Maintenance Action

Glossary Text: Consists of maintenance action required on the actual structural health monitoring system, including, sensors, power, data acquisition, etc.

Operational Activity: Install Data Collection Device

Glossary Text: Install the data collection device onto the aircraft in accordance with the data collection plan.

Operational Activity: Install ISHM System

Glossary Text: Consists of all actions taken to install the ISHM System. May include installing sensors, data collection device and software.

Operational Activity: Install Sensors

Glossary Text: Install sensors onto the aircraft in accordance with the sensor selection plan.

Operational Activity: Install Software

Glossary Text: Install necessary ISHM System software in accordance with the data collection plan.

Operational Activity: Monitor Structural Health

Glossary Text: Consists of all actions and components necessary in monitoring the structural health of an aircraft.

Operational Activity: Operate ISHM System

Glossary Text: Consists of all activities accomplished in the normal operation of an integrated structural health monitoring systems. Includes data collection, analysis and processing.

Operational Activity: Process Data

Glossary Text: Data Processing includes all activities required to transform the raw data into usable information, such as charts and/or tables.

Operational Activity: Recommend Action

Glossary Text: Consists of recommended actions to accomplish to the aircraft or fleet based on the discovery of a structural problem.

Operational Activity: Run Aircraft Historical Processing

Glossary Text: Filtered data is compared against historical aircraft records to determine if any new structural damage is present.

Operational Activity: Run Detailed Analysis

Glossary Text: Consists of detailed analysis of data to determine if a structural problem exists. Includes information such as type, size, location and criticality.

Operational Activity: Run Fleet Historical Processing

Glossary Text: Filtered data is compared against historical fleet records to determine if new structural damage is present and determine if any fleet wide trends are emerging

Operational Activity: Run Mission Processing

Glossary Text: Filtered Data is run against mission parameters to determine if any structural damage is present as a result of the mission.

Operational Activity: Run Trend Analysis

Glossary Text: Consists of detailed analysis of mission, aircraft and fleet trends to determine if a specific action is the cause of a structural problem.

Operational Activity: Store Data

Glossary Text: Consists of storing the raw data taken from the sensor to retrieve at a later time.

Operational Activity: Train Engineers

Glossary Text: Train engineers in accordance with engineer requirements.

Operational Activity: Update Inspection Requirements

Glossary Text: Consists of adding on changing aircraft or fleet inspection requirements based on damage.

Operational Activity: Utilize Results

Glossary Text: Utilizing the results involves taking the recommendations generated from the data analysis and performing the action on the specific structural area. This may include an inspection, repair, or other maintenance action.

ICOMS:

ICOM line: Aircraft Design

Glossary Text: Consists of the physical design of the aircraft including size and space dimensions.

ICOM line: Aircraft Structural Health Report

Glossary Text: Consists of detailed information regarding the specific structural test reported in a format that will be understood to the trained user. Consists of graphs, charts, and historical information about the aircraft and fleet.

ICOM line: Analysis Results

Glossary Text: Consists of the results drawn from the processed data. Includes recommendations on actions to take relative to the subject material.

ICOM line: Completed Structural Health Maintenance Action

Glossary Text: Consists of completion of the recommended maintenance action, flight restriction or inspection procedure.

ICOM line: Cost / Budget

Glossary Text: Consists of the money available to fund the ISHM System.

ICOM line: Data Collection Device

Glossary Text: Consists of the Data Collection Device for the ISHM System

ICOM line: Data Collection Plan

Glossary Text: Consists of a detailed plan on what technology the data collection devices are, and how they will be positioned and used.

ICOM line: Data Collection Requirements

Glossary Text: Consists of the data requirements necessary for a functional ISHM System. Includes data format, storage, bandwidth, etc.

ICOM line: Data Request

Glossary Text: A Request for data to be sent.

ICOM line: Engineer Requirements

Glossary Text: Consists of the engineer requirements necessary for a functional ISHM System. Includes training, processes, and structural knowledge.

ICOM line: Engineering Expertise

Glossary Text: Trained Engineers that are required to interpret the processed data into actual maintenance recommendations.

ICOM line: Engineers

Glossary Text: Consist of a team of experts that are familiar with the design of the aircraft.

ICOM line: Environment

Glossary Text: Consists of things that may be beyond the user's control. May include, temperature, vibration, acoustics, exposure to elements, size of area, etc.

ICOM line: Filtered Data

Glossary Text: Consists of data that has been filtered to show relevant parameters and information.

ICOM line: Flight Parameters

Glossary Text: Consists of flight parameters for a specific mission.

ICOM line: Flight Profile

Glossary Text: Consists of flight parameters that the aircraft is able and expected to perform over its life.

ICOM line: Historical Data

Glossary Text: Consists of historical data concerning the structural history of the specific aircraft, or fleet of aircraft.

ICOM line: Maintenance Practices

Glossary Text: Consists of common practices for the specific aircraft. May include things such as how often an area is accessed for maintenance and what inspection procedures and intervals the ISHM System would have.

ICOM line: Maintenance Requirements

Glossary Text: Consists of the maintenance requirements necessary for a functional ISHM System. May include, maintainability, reliability, availability, accessibility, etc.

ICOM line: Maintainers

Glossary Text: Consists of the personnel that maintain the aircraft and the ISHM System.

ICOM line: Operational Requirements

Glossary Text: Consists of the operational requirements necessary for a functional ISHM System. Includes operational concept, environmental factors, etc.

ICOM line: Operational Data Collection Device

Glossary Text: Data Collection devices that are fully operational and prepared to store and process data.

ICOM line: Operational Sensors

Glossary Text: Sensors that are fully operational and prepared to measure data.

ICOM line: Operational Software

Glossary Text: Software that is fully operational and prepared to process data.

ICOM line: Raw Data

Glossary Text: Consists of data in unmodified terms. It is simply the raw numbers recorded by the sensor.

ICOM line: Recommended Maintenance Action

Glossary Text: Consists of recommendations on further action regarding the structural member of interest. They may include flight restrictions, inspection procedures, intervals, or repair procedures.

ICOM line: Sensor Properties

Glossary Text: Consists of properties such as temperature range, accuracy, frequency, size, sampling rate, etc.

ICOM line: Sensor Requirements

Glossary Text: Consists of the sensor requirements necessary for a functional ISHM System. Includes frequency, location, size, sampling rates, quantity, etc.

ICOM line: Sensor Selection Plan

Glossary Text: Consists of a detailed plan on what technology the sensors are, and how they will be positioned and used.

ICOM line: Sensors

Glossary Text: Consists of the sensors and wiring that make up the ISHM System

ICOM line: Stakeholder Input

Glossary Text: Consists of input from stakeholders such as user, engineering support, designer, or maintainer.

ICOM line: Stakeholders

Glossary Text: Consists of the group of people that have an interest in the ISHMS system. May include engineers, maintainers, budget personnel, etc.

ICOM line: Software

Glossary Text: Consists of the Processing and Database Software for the ISHM System

ICOM line: System Health Report

Glossary Text: Consists of an assessment on system health based on self-diagnostic readings and analysis of data reported.

ICOM line: Technology

Glossary Text: Consists of the actual technologies used by the ISHM System including, sensors, data collection devices and processing software.

ICOM line: Test Completion

Glossary Text: Consists of a signal that the test has completed.

ICOM line: Test Initiation

Glossary Text: The action that is taken to generate a test on a specific aircraft structural component.

Appendix B. First Generation Sensor Test Plots

Pulse-Echo (Sensor 0072): 08 Nov 06, Block 1 @ 6" and 0°, No Damage Baseline



Pulse-Echo: 35 kHz Sensor 0072

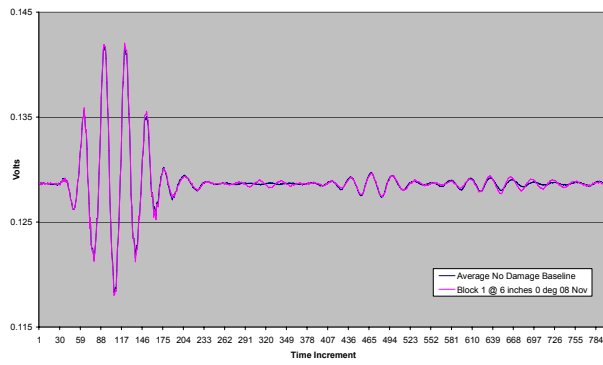

Pulse-Echo (0072): 35kHz (No Damage Average - 08 Nov Block 1) Delta

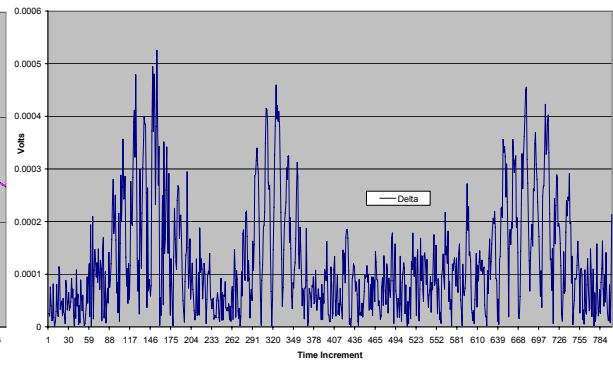

Pulse-Echo (0072): 35kHz (No Damage Average - 08 Nov Baseline) Delta

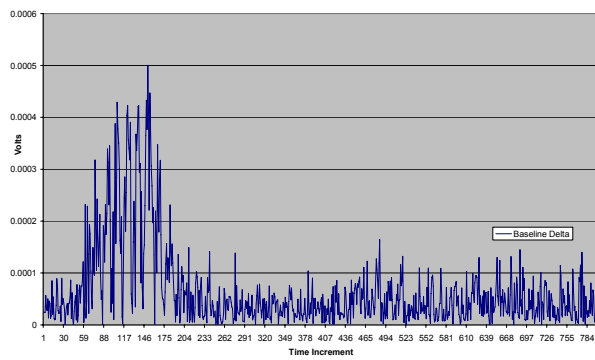

Pulse-Echo: 65kHz Sensor 0072

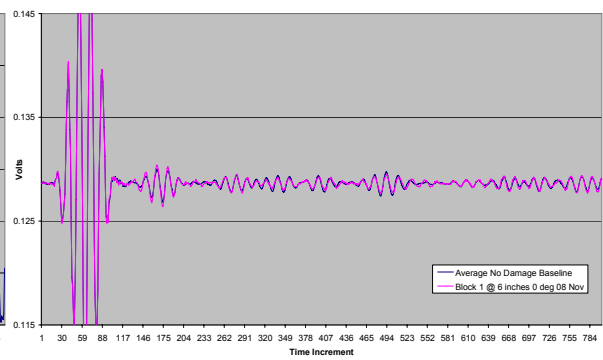

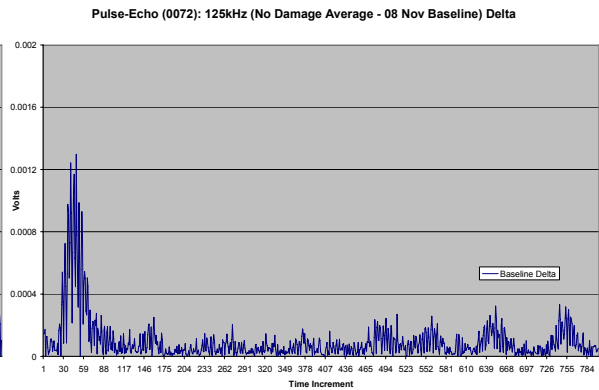
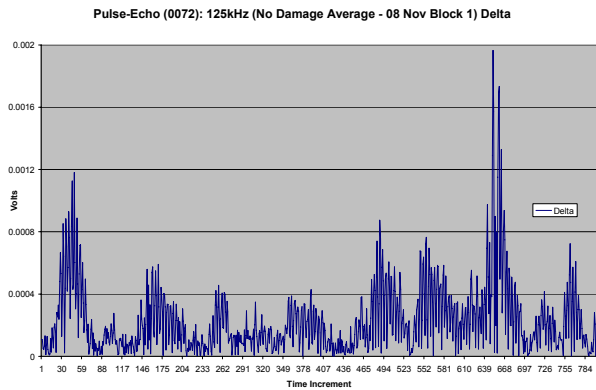
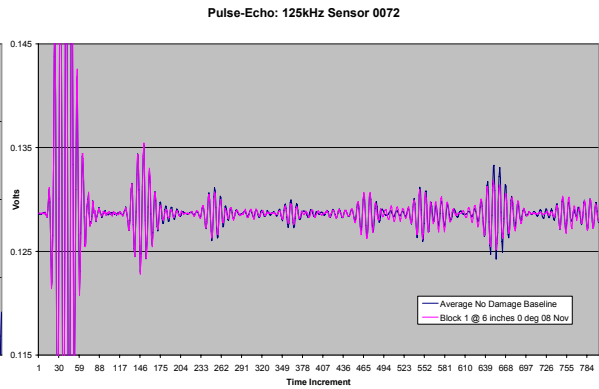
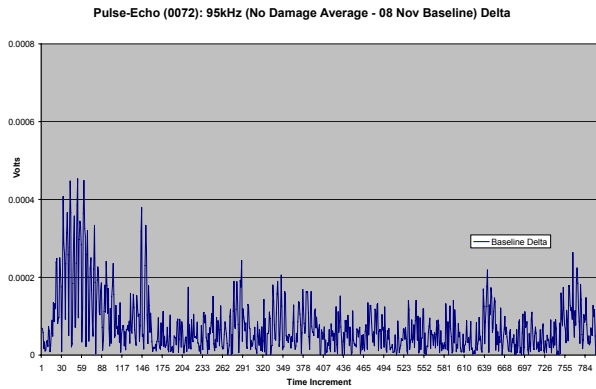
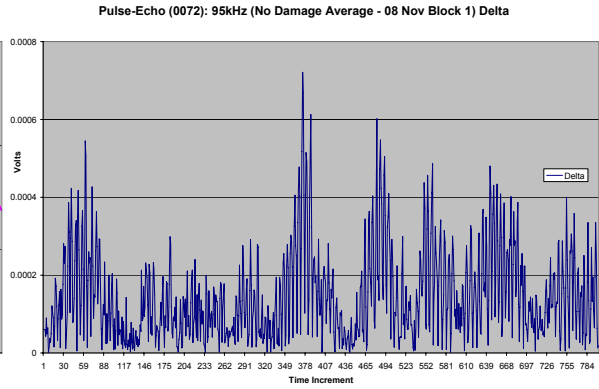
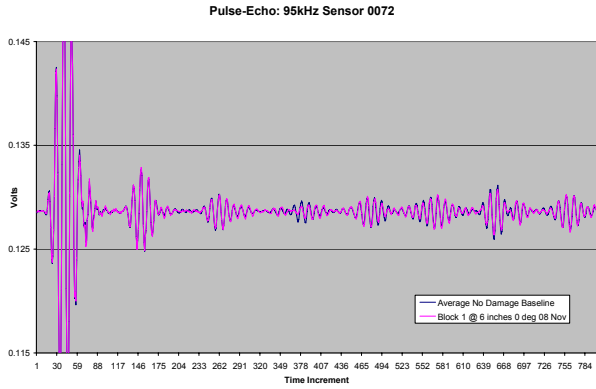
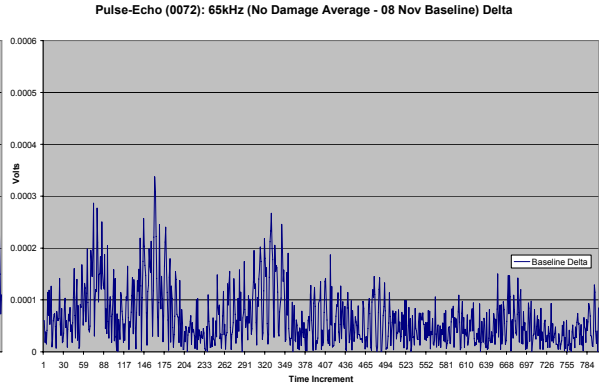
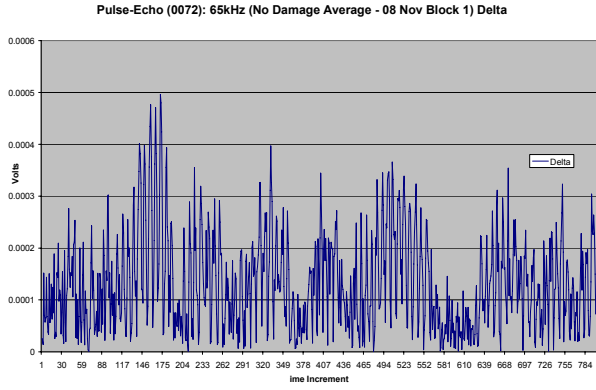

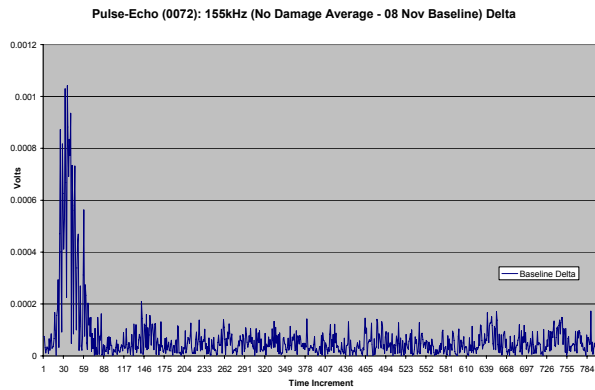
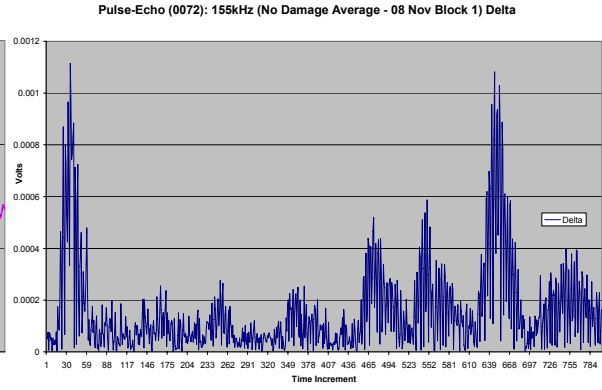
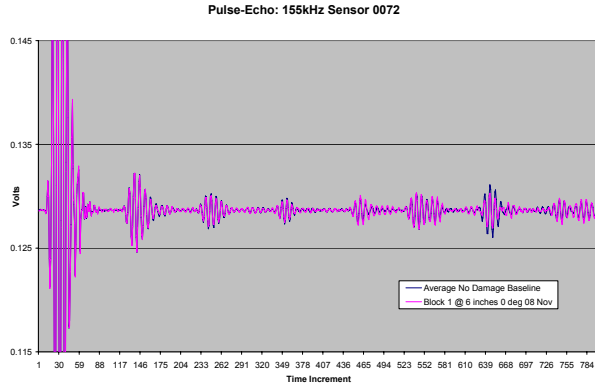

Pulse-Echo (Sensor 0072): 08 Nov 06, Block 2 @ 6" and 0°, No Damage Baseline

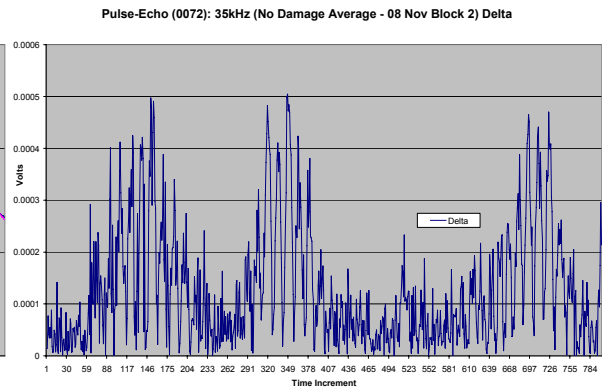
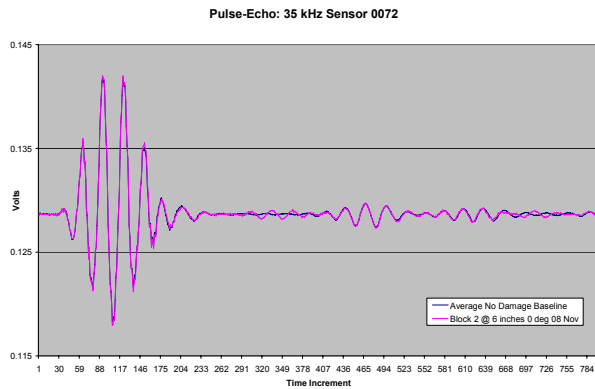
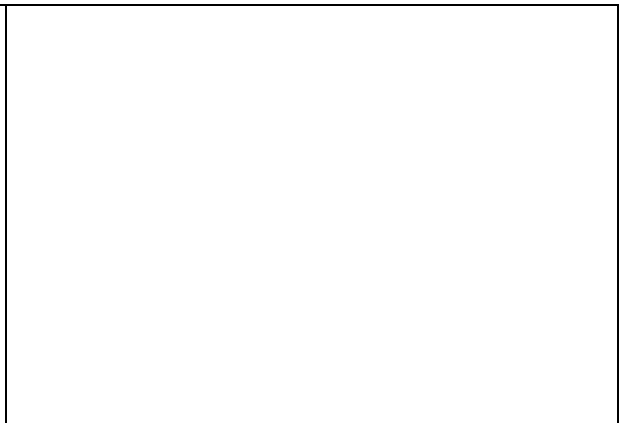
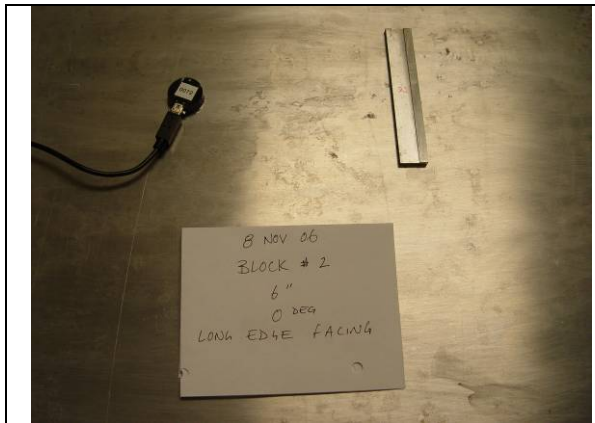

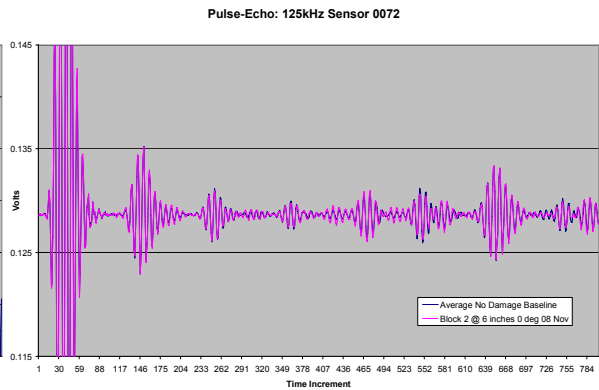
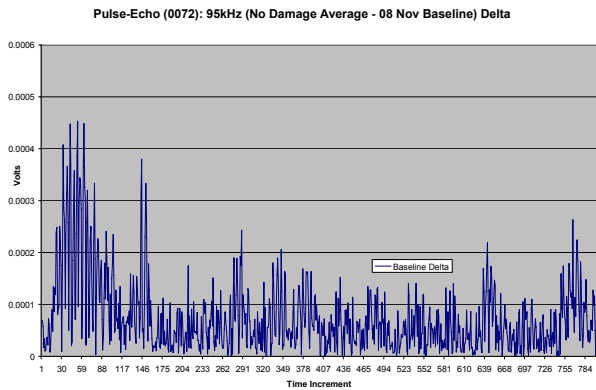
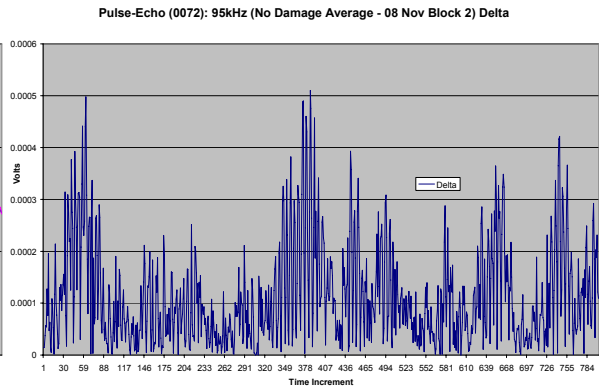
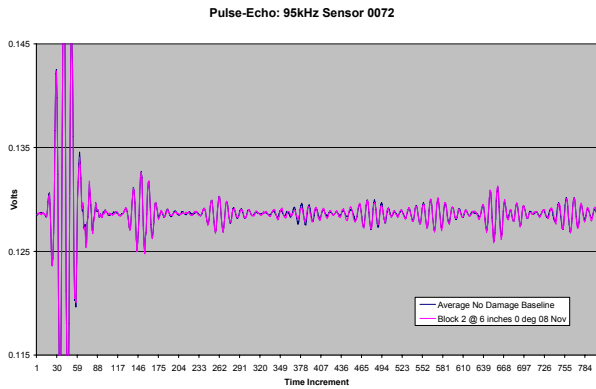
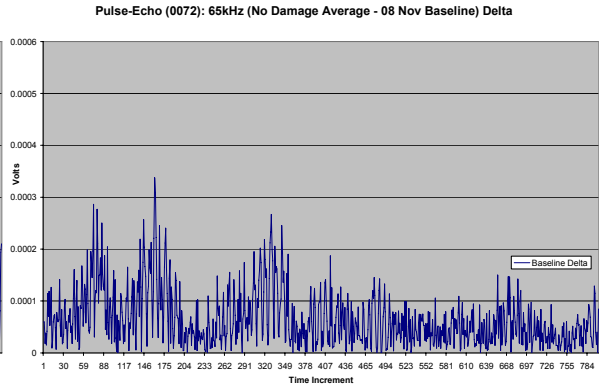
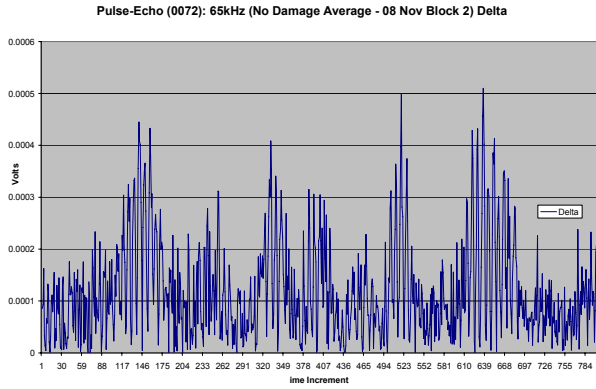
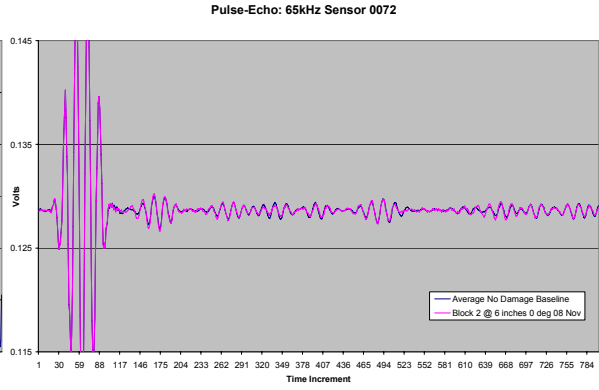
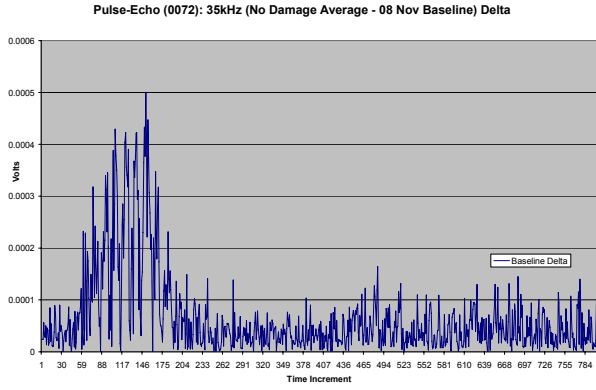

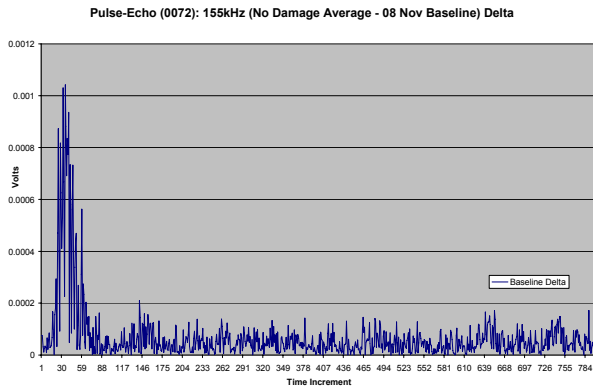
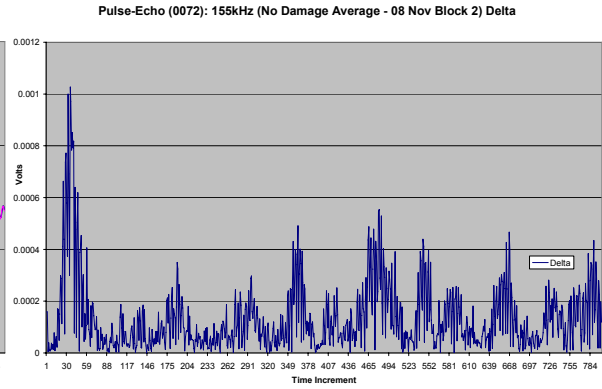
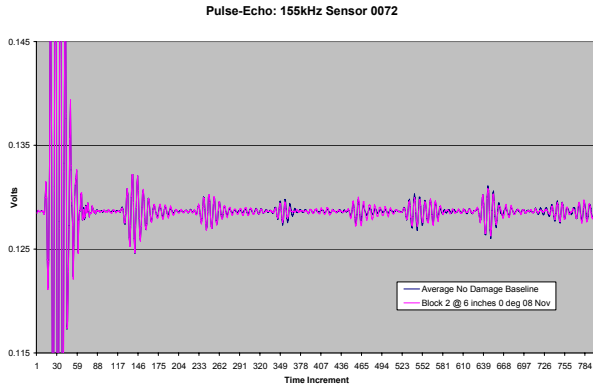
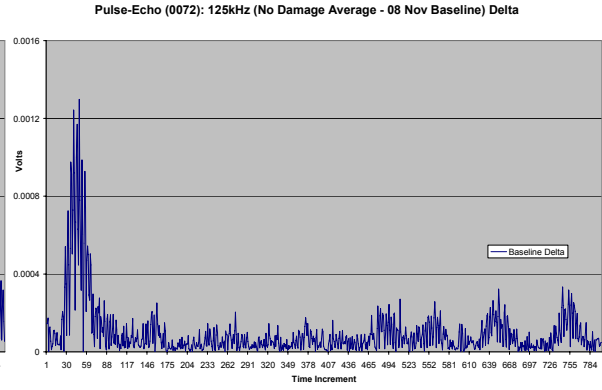
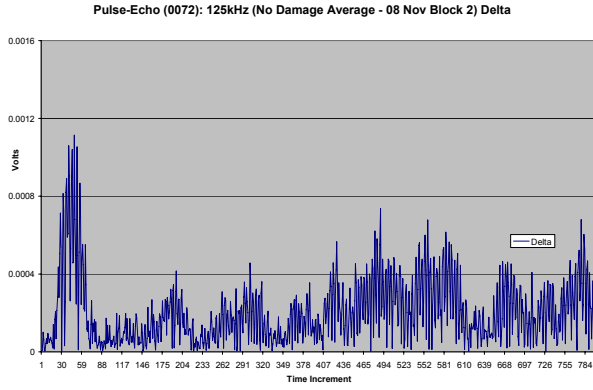

Pulse-Echo (Sensor 0072): 10 Nov 06, Block 1 @ 16" and 0°, No Damage Baseline

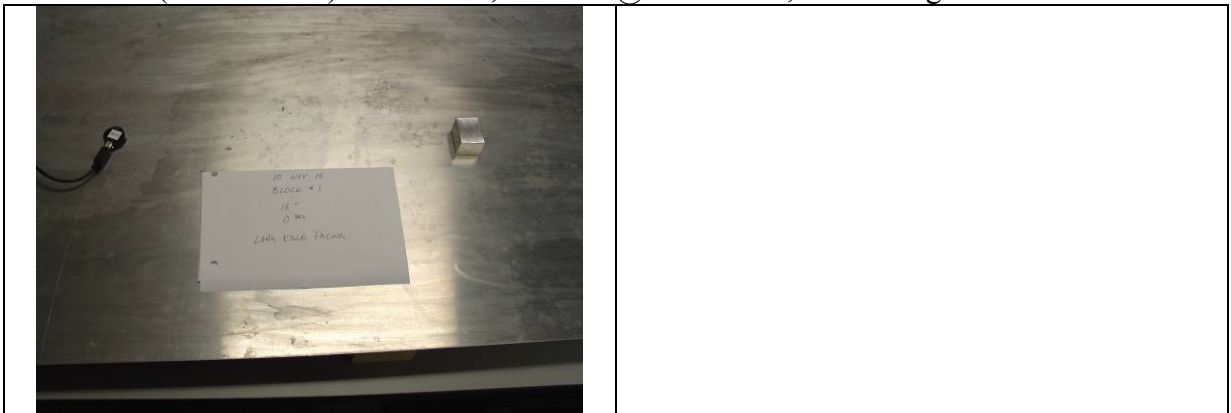

Pulse-Echo: 35 kHz Sensor 0072

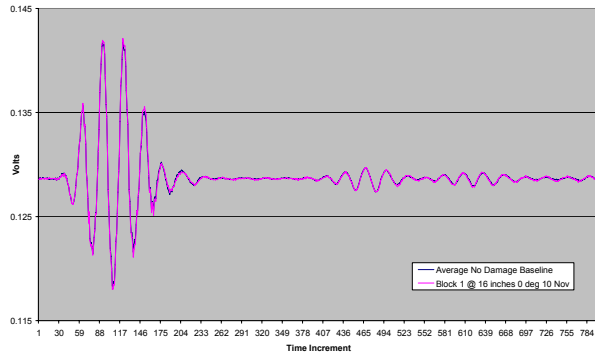

Pulse-Echo (0072): 35kHz (No Damage Average - 10 Nov Block 1) Delta

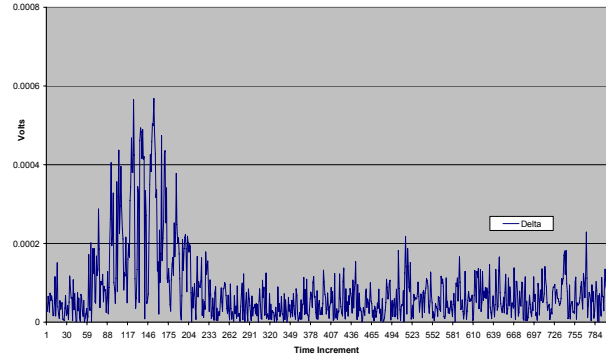

Pulse-Echo (0072): 35kHz (No Damage Average - 10 Nov Baseline) Delta

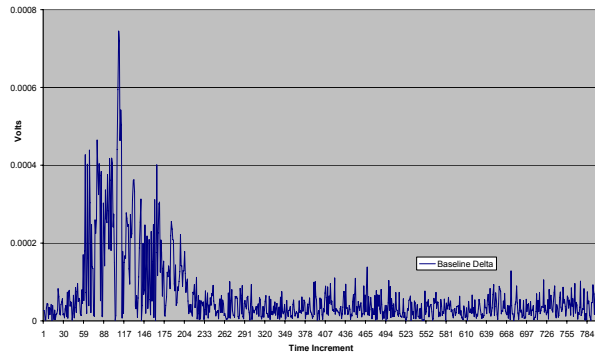

Pulse-Echo: 65kHz Sensor 0072

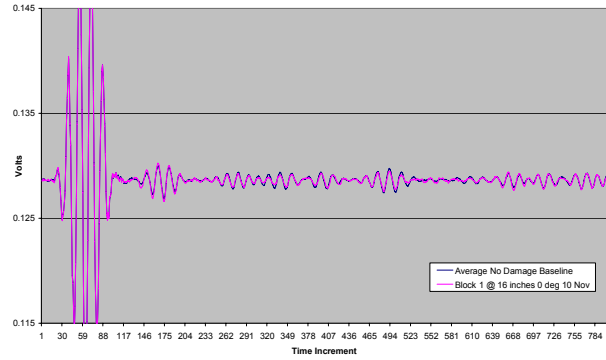

Pulse-Echo (0072): 65kHz (No Damage Average - 10 Nov Block 1) Delta

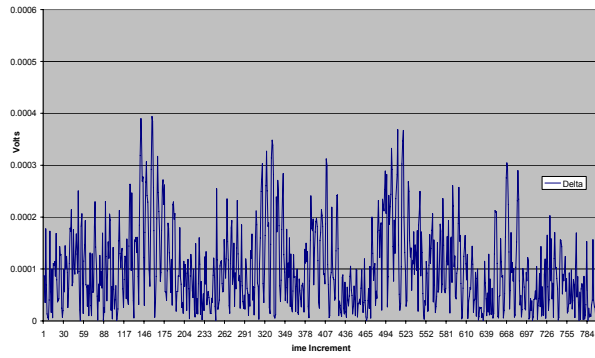

Pulse-Echo (0072): 65kHz (No Damage Average - 10 Nov Baseline) Delta

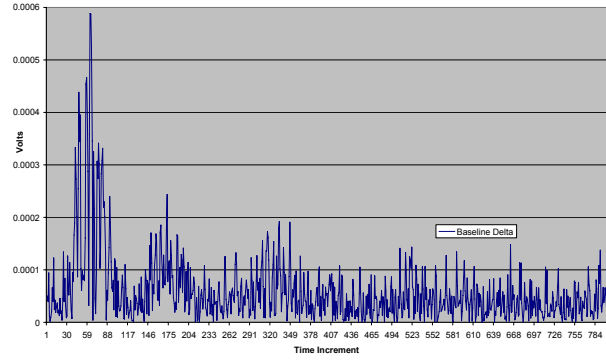

Pulse-Echo: 95kHz Sensor 0072

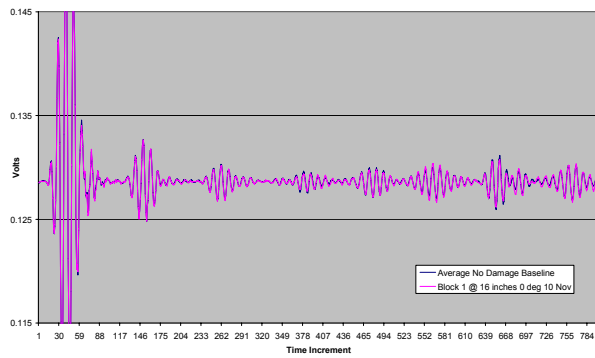

Pulse-Echo (0072): 95kHz (No Damage Average - 10 Nov Block 1) Delta

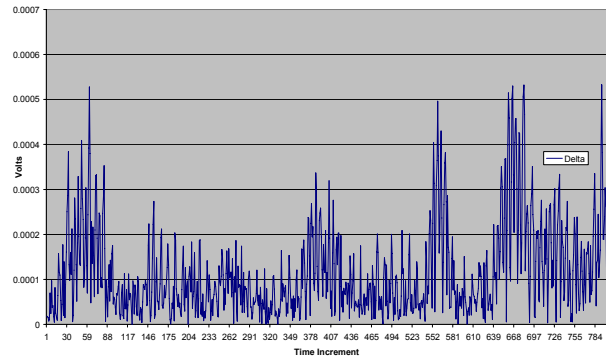

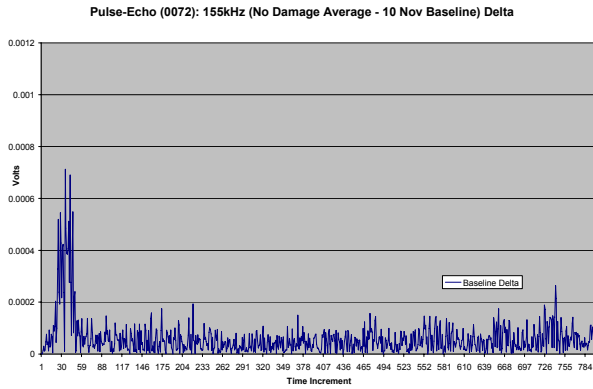
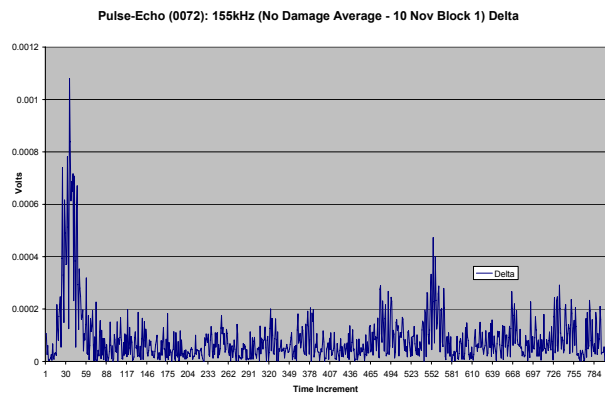
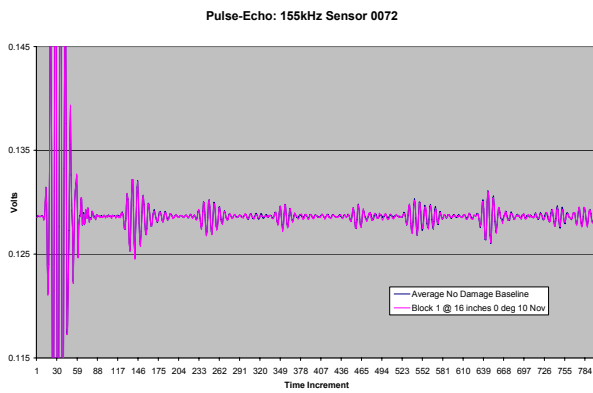
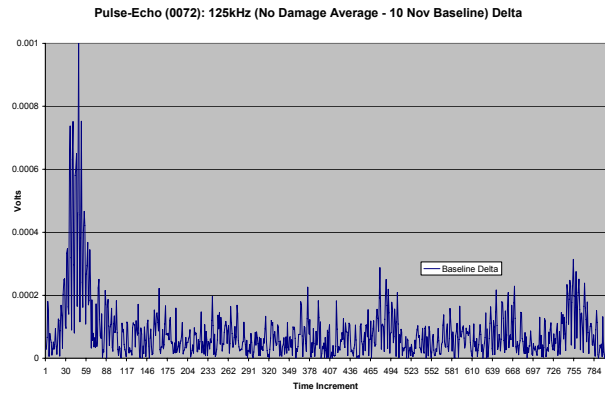
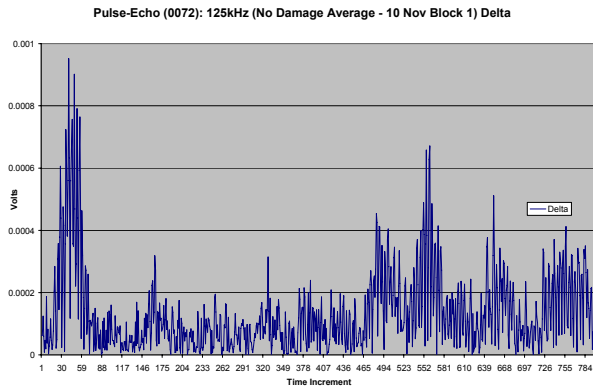
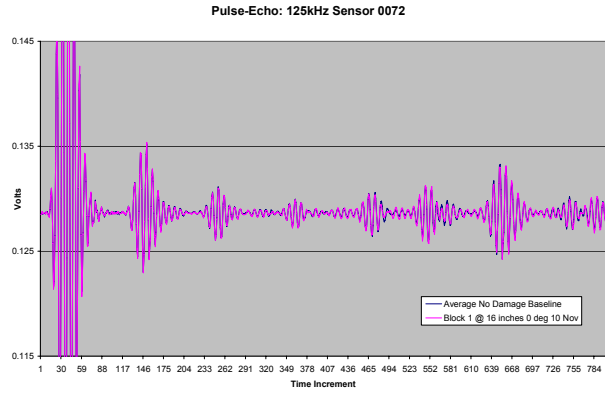
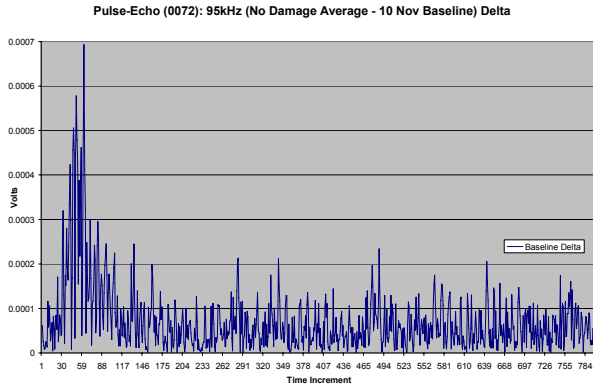

Pulse-Echo (Sensor 0072): 10 Nov 06, Block 2 @ 6" and 90°, No Damage Baseline

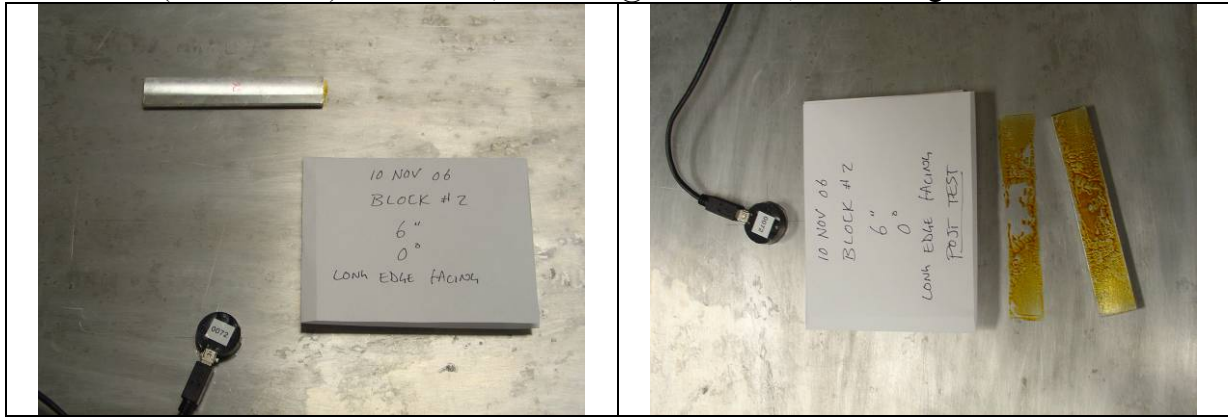

Pulse-Echo: 35 kHz Sensor 0072

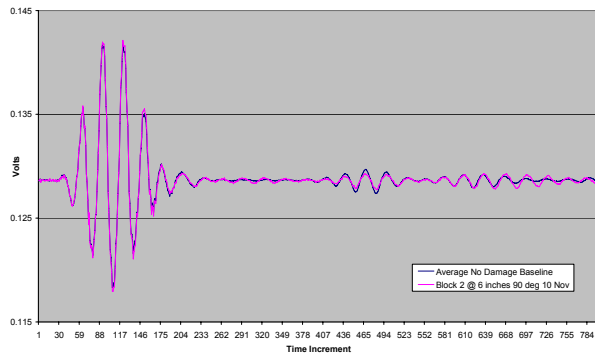

Pulse-Echo (0072): 35kHz (No Damage Average - 10 Nov Block 2) Delta

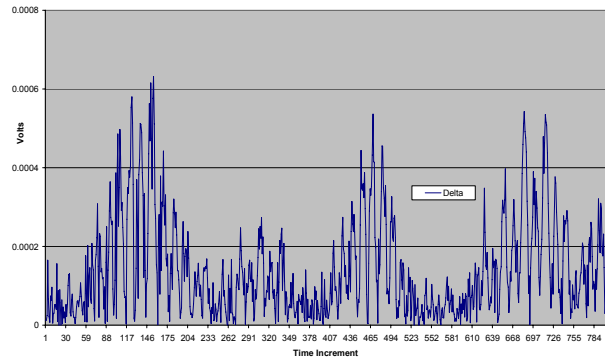

Pulse-Echo (0072): 35kHz (No Damage Average - 10 Nov Baseline) Delta

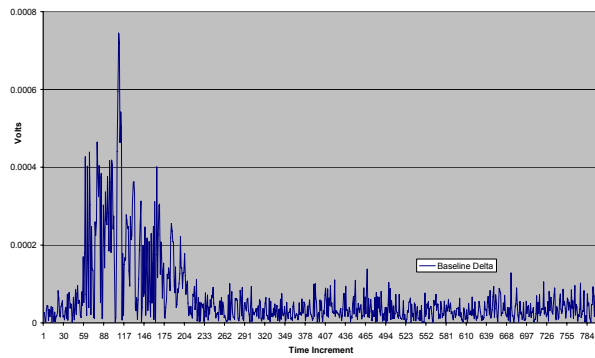

Pulse-Echo: 65kHz Sensor 0072

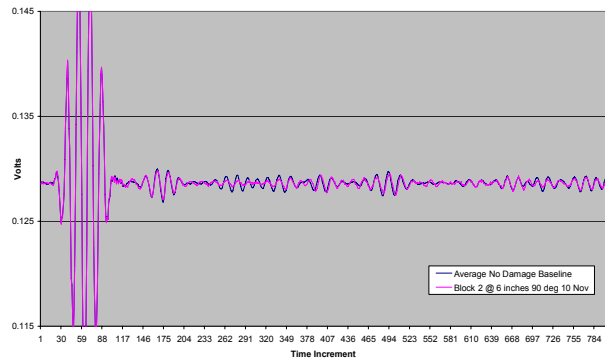

Pulse-Echo (0072): 65kHz (No Damage Average - 10 Nov Block 2) Delta

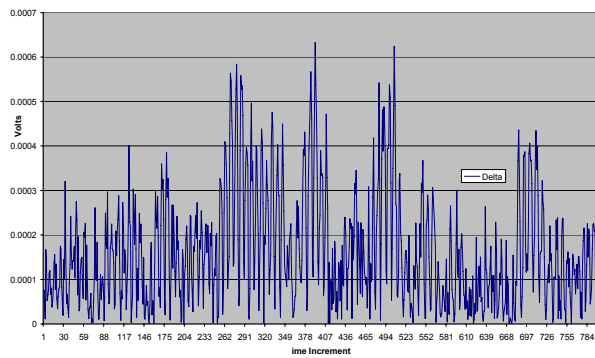

Pulse-Echo (0072): 65kHz (No Damage Average - 10 Nov Baseline) Delta

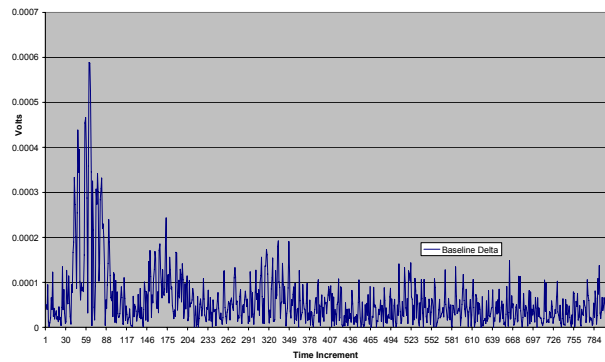

Pulse-Echo: 95kHz Sensor 0072

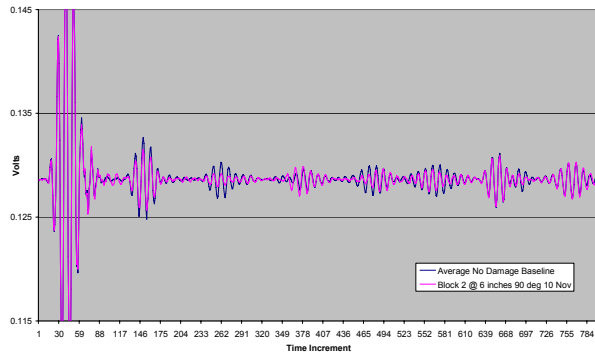

Pulse-Echo (0072): 95kHz (No Damage Average - 10 Nov Block 2) Delta

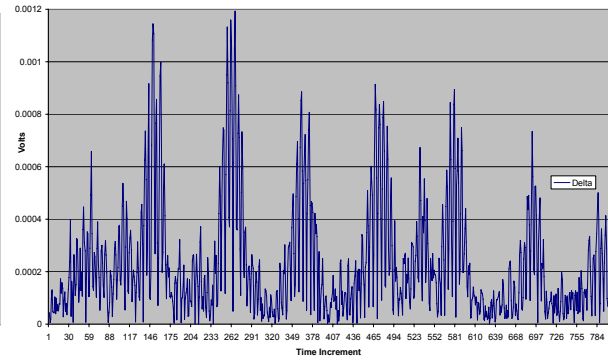

Pulse-Echo (0072): 95kHz (No Damage Average - 10 Nov Baseline) Delta

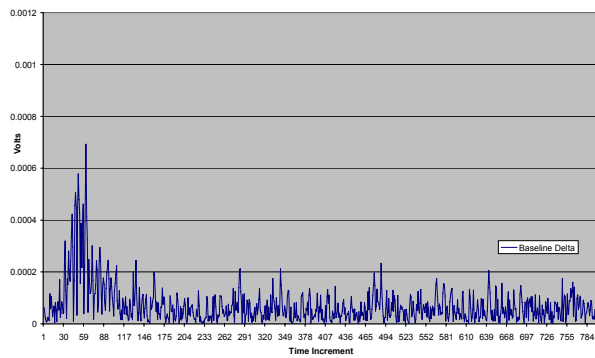

Pulse-Echo: 125kHz Sensor 0072

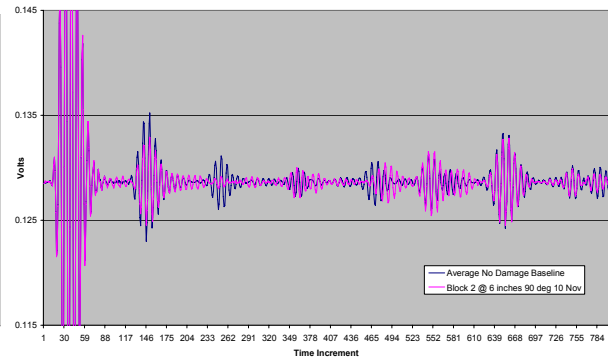

Pulse-Echo (0072): 125kHz (No Damage Average - 10 Nov Block 2) Delta

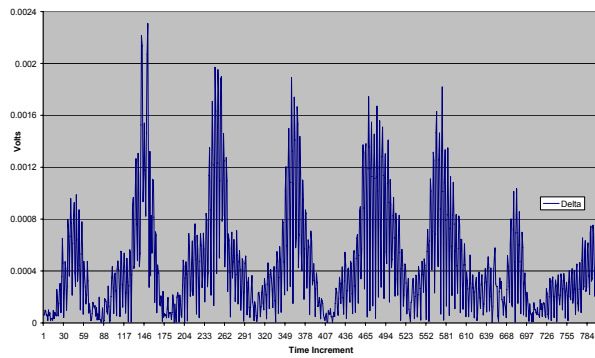

Pulse-Echo (0072): 125kHz (No Damage Average - 10 Nov Baseline) Delta

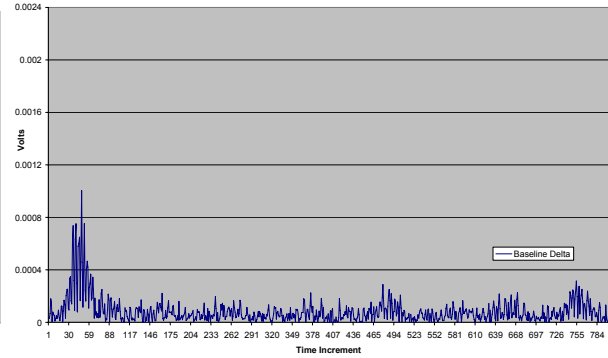

Pulse-Echo: 155kHz Sensor 0072

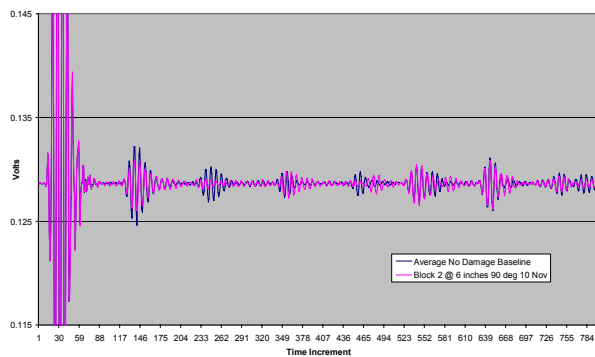

Pulse-Echo (0072): 155kHz (No Damage Average - 10 Nov Block 2) Delta

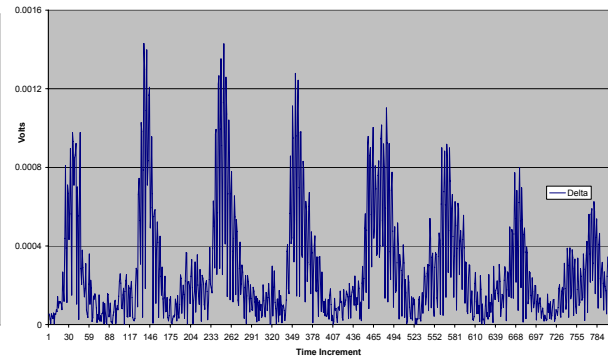

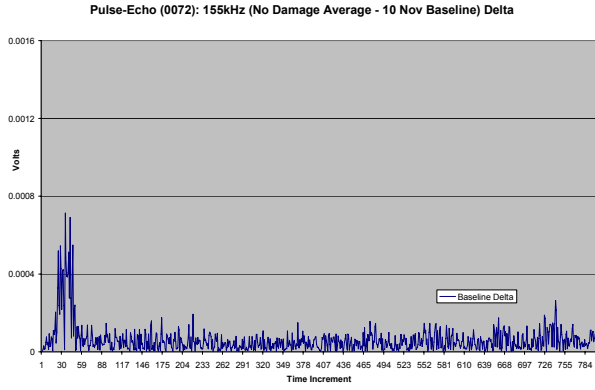

Pulse-Echo (Sensor 0072): 10 Nov 06, Block 2 @ 6" and 90°, Angled 45°, No Damage Baseline



Pulse-Echo: 35 kHz Sensor 0072

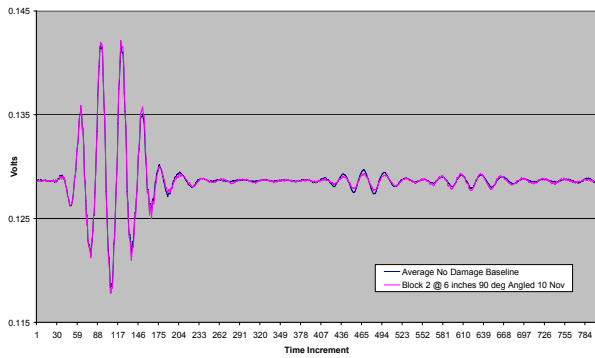

Pulse-Echo (0072): 35kHz (No Damage Average - 10 Nov Block 2 Run2) Delta

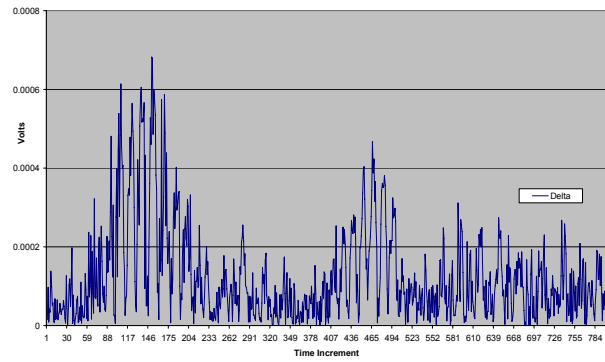

Pulse-Echo (0072): 35kHz (No Damage Average - 10 Nov Baseline) Delta

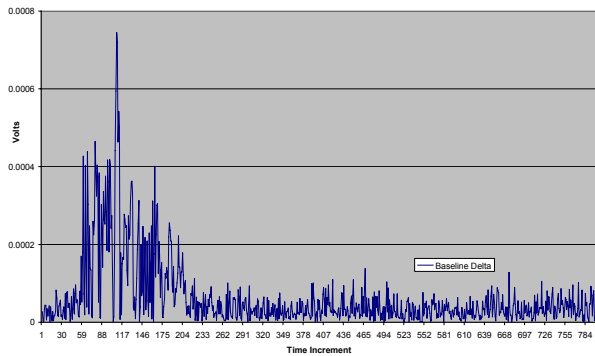

Pulse-Echo: 65kHz Sensor 0072

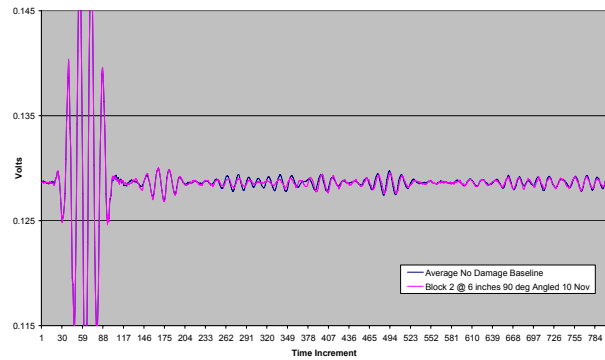

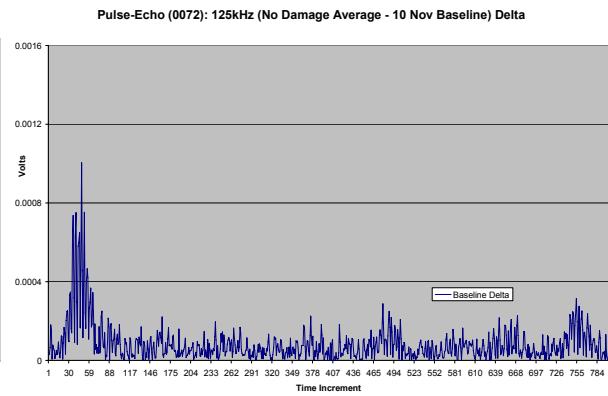
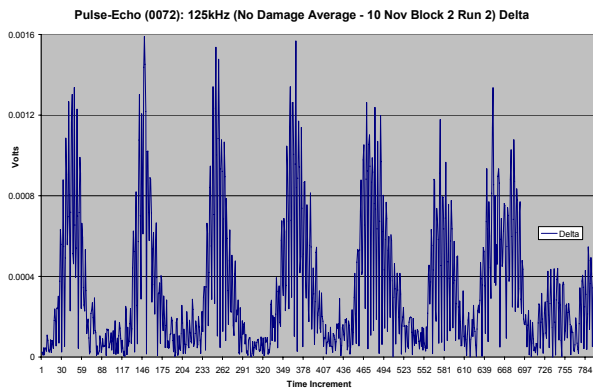
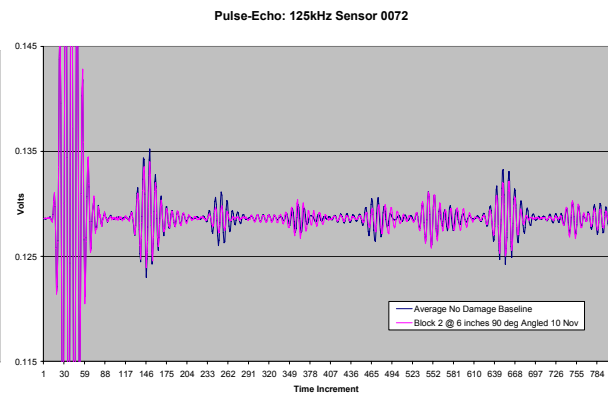
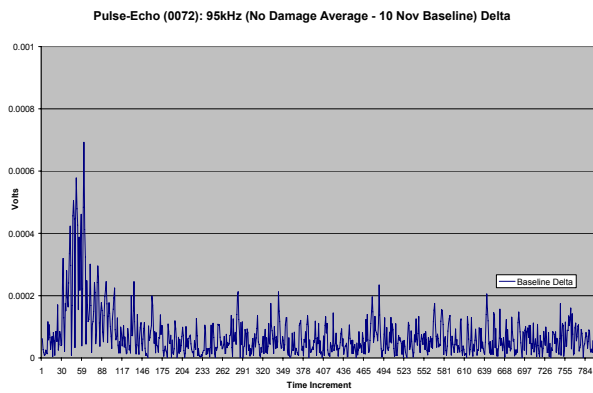
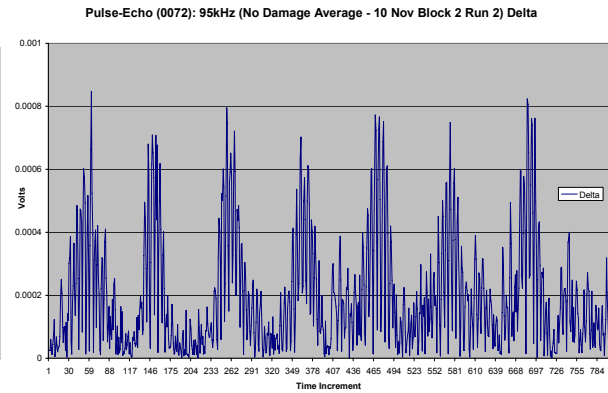
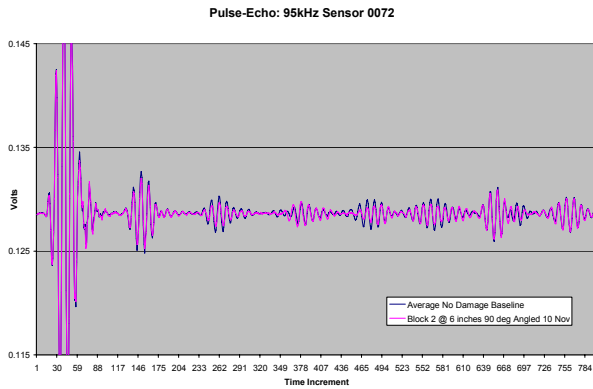
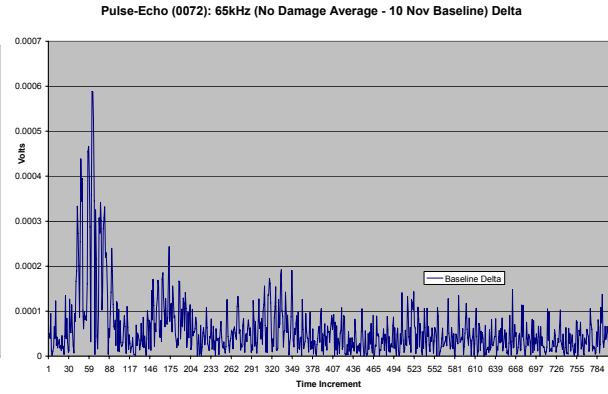
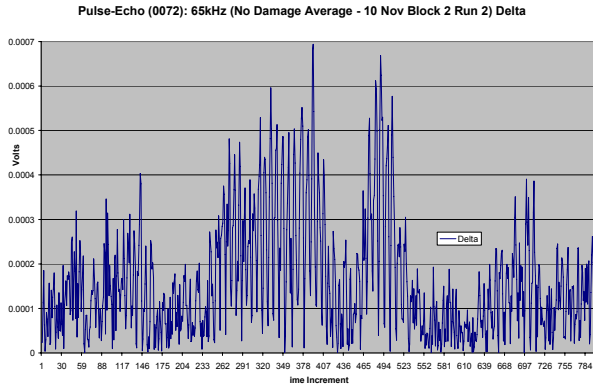

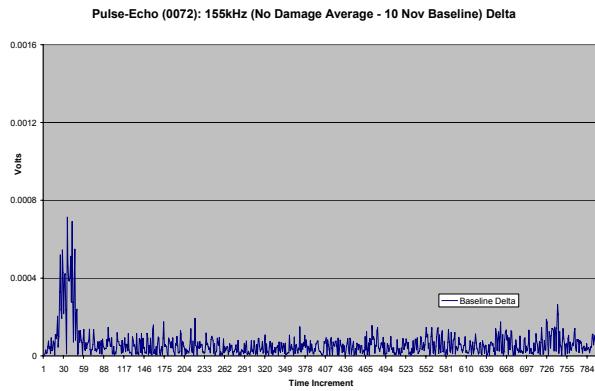
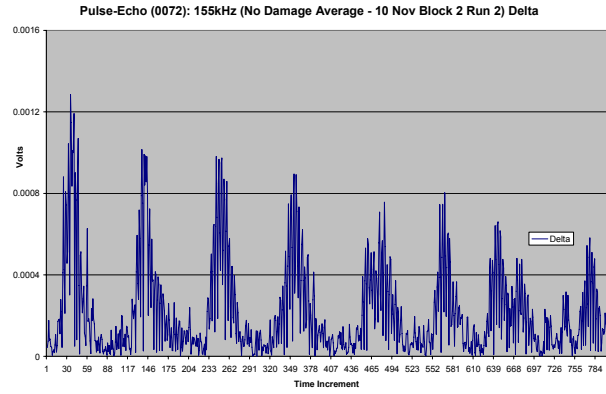
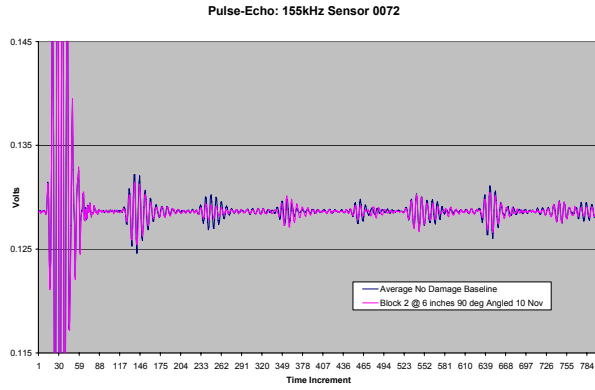

Pulse-Echo (Sensor 0072): 10 Nov 06, Block 2 @ 6" and 0°, Short Edge, No Damage Baseline

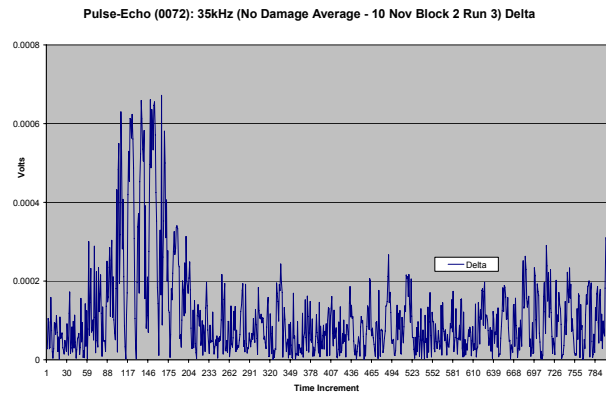
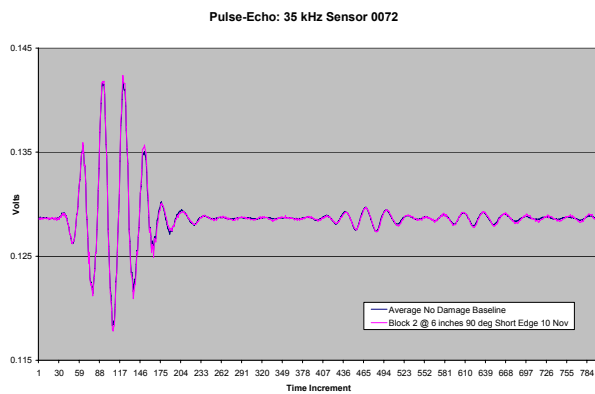
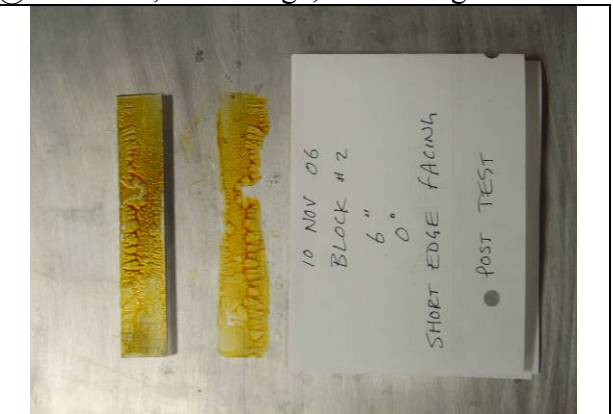
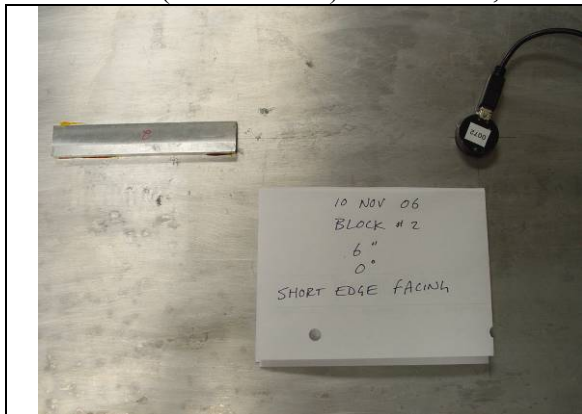

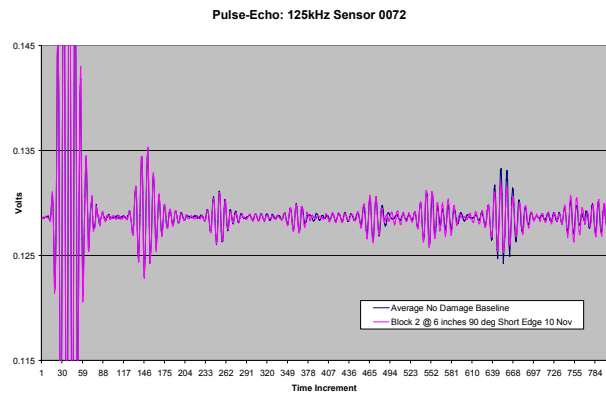
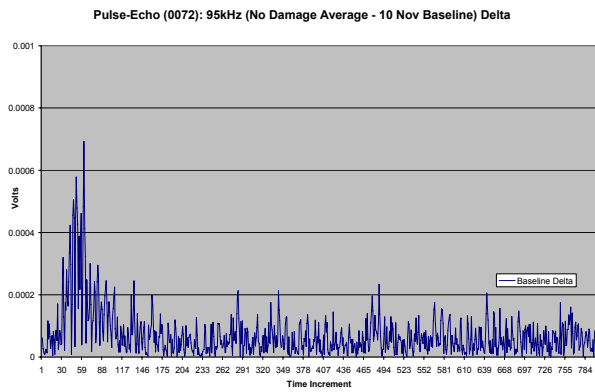
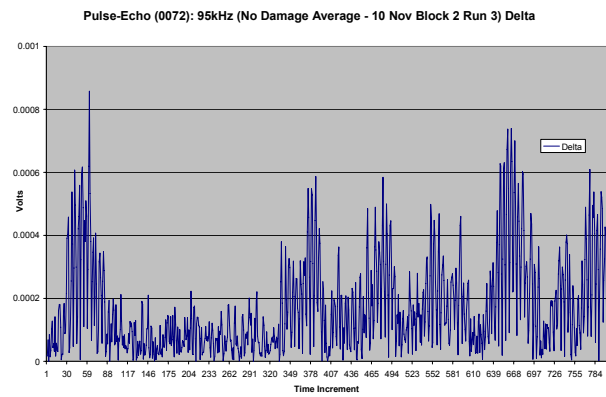
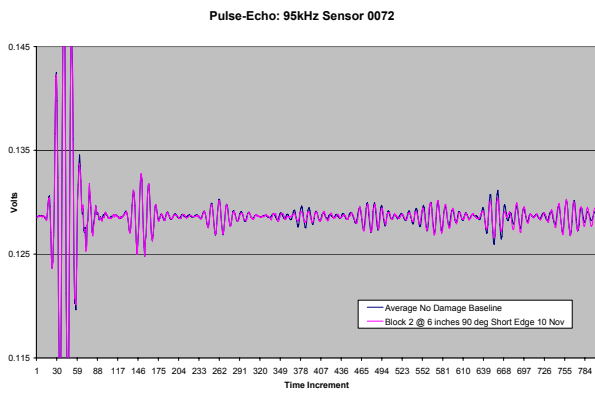
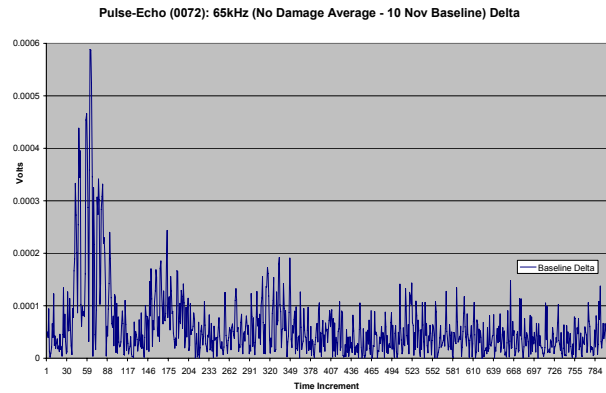
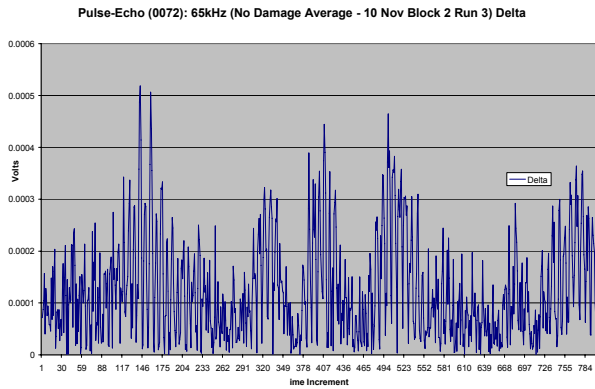
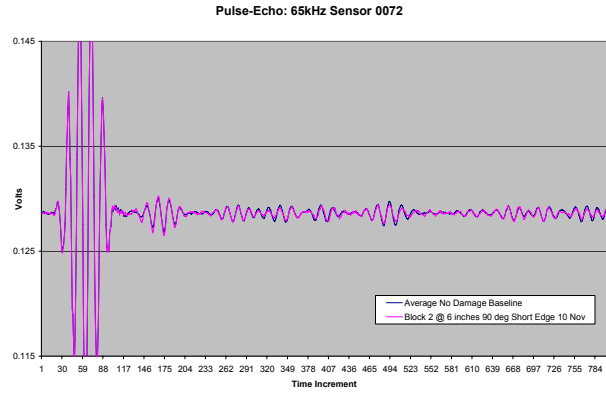
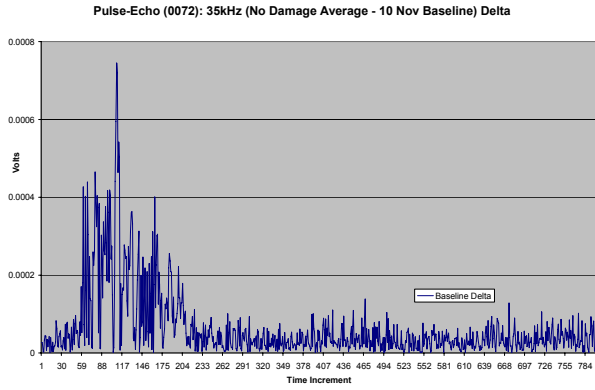

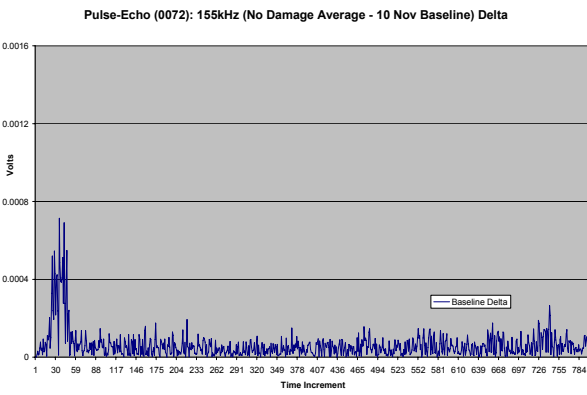
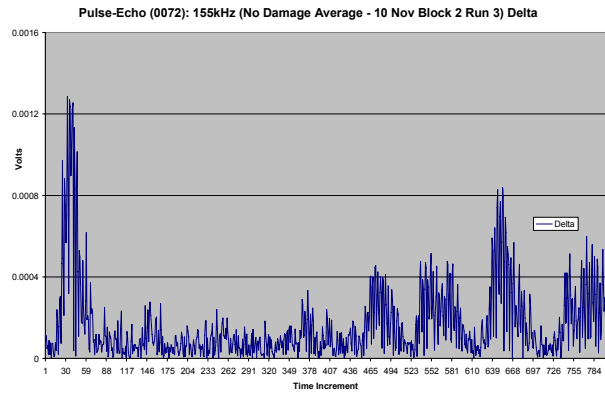
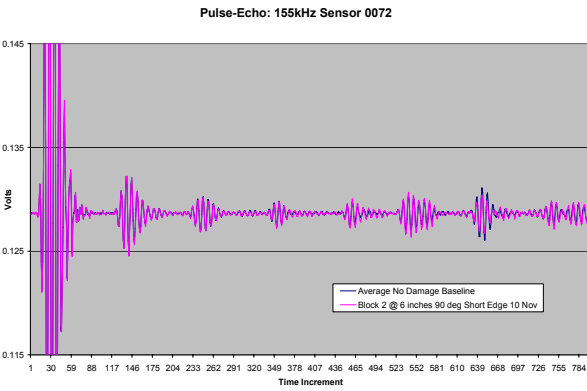
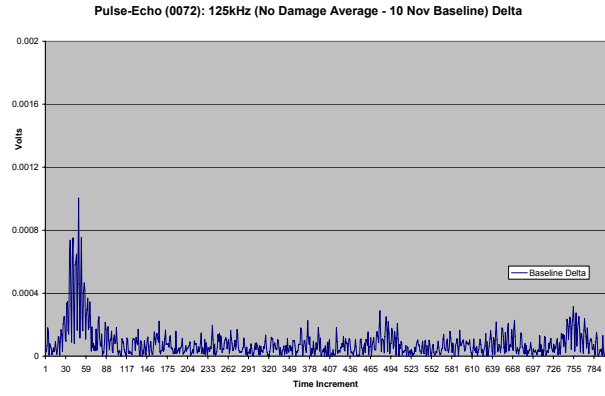
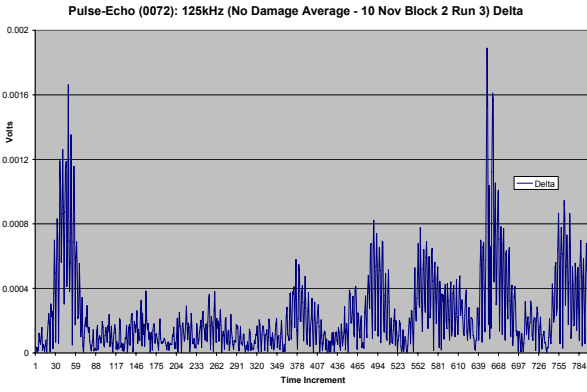

Pulse-Echo (Sensor 0072): 10 Nov 06, Block 2 @ 10.5" and 0°, No Damage Baseline

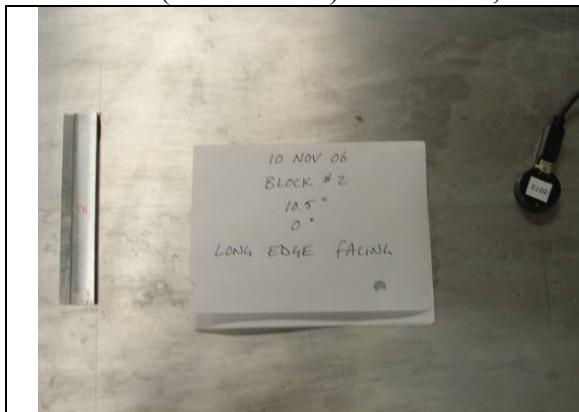

Pulse-Echo: 35 kHz Sensor 0072

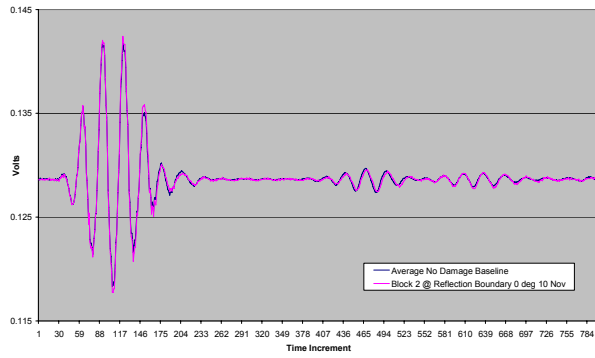

Pulse-Echo (0072): 35kHz (No Damage Average - 10 Nov Block 2 Run 4)

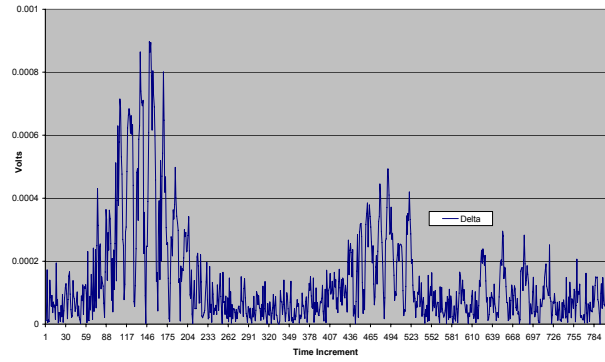

Pulse-Echo (0072): 35kHz (No Damage Average - 10 Nov Baseline) Delta

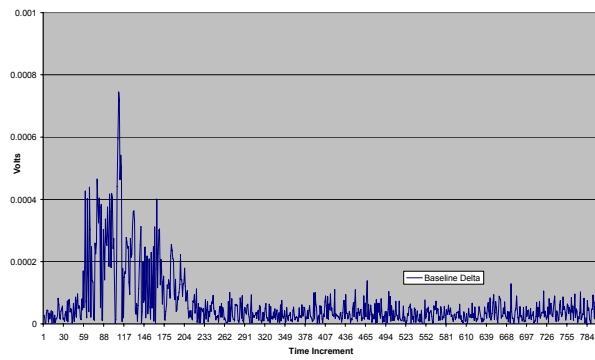

Pulse-Echo: 65kHz Sensor 0072

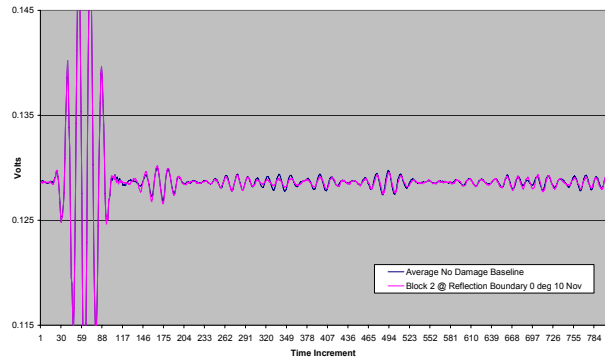

Pulse-Echo (0072): 65kHz (No Damage Average - 10 Nov Block 2 Run 4)

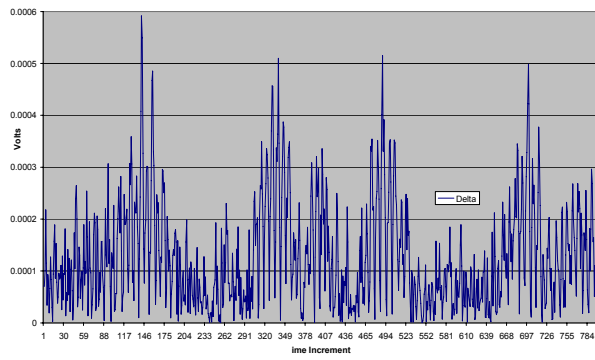

Pulse-Echo (0072): 65kHz (No Damage Average - 10 Nov Baseline) Delta

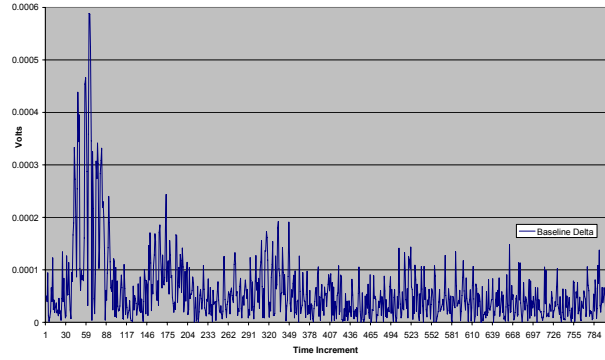

Pulse-Echo: 95kHz Sensor 0072

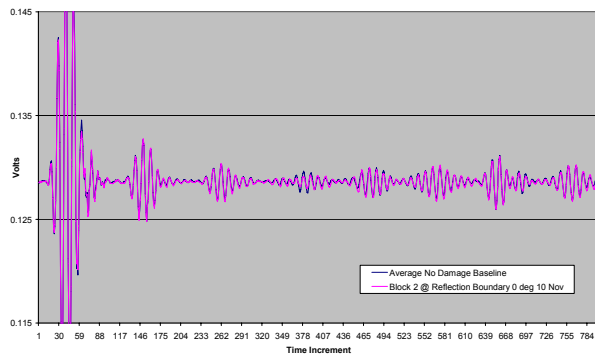

Pulse-Echo (0072): 95kHz (No Damage Average - 10 Nov Block 2 Run 4)

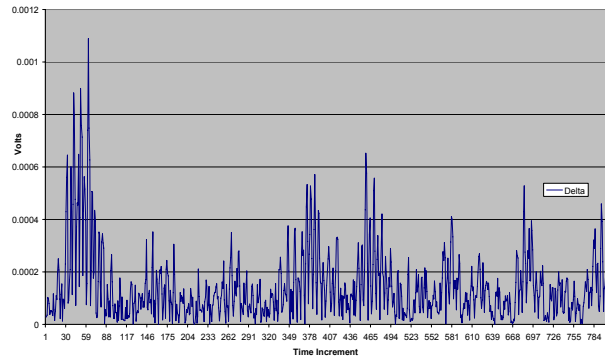

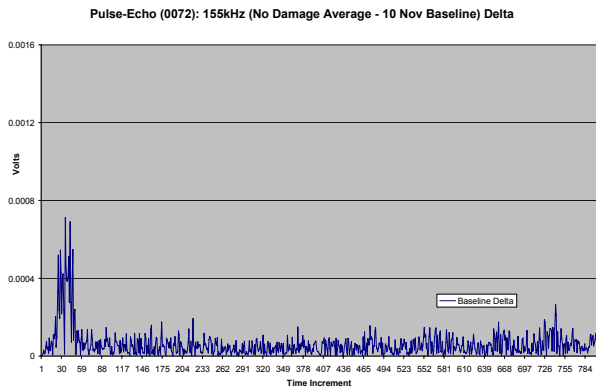
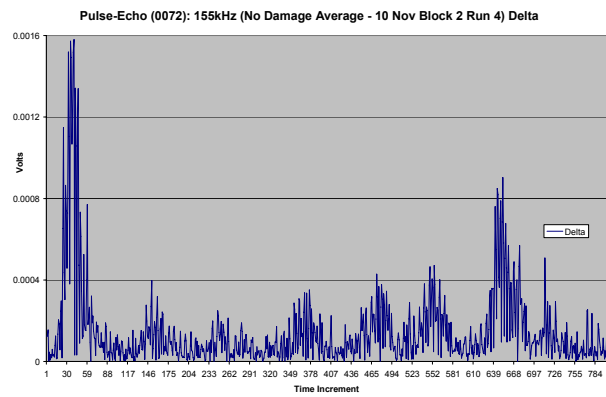
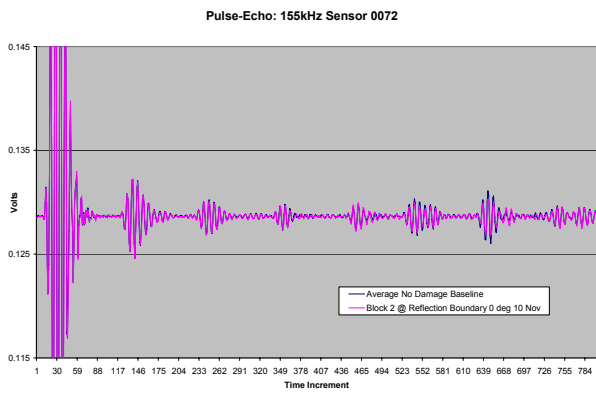
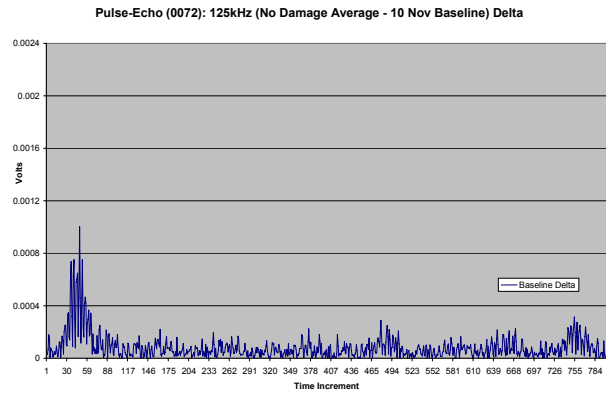
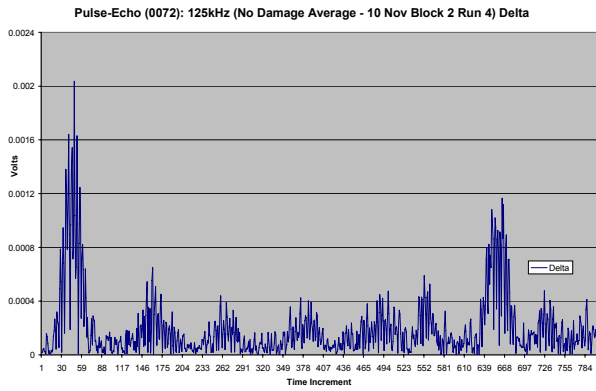
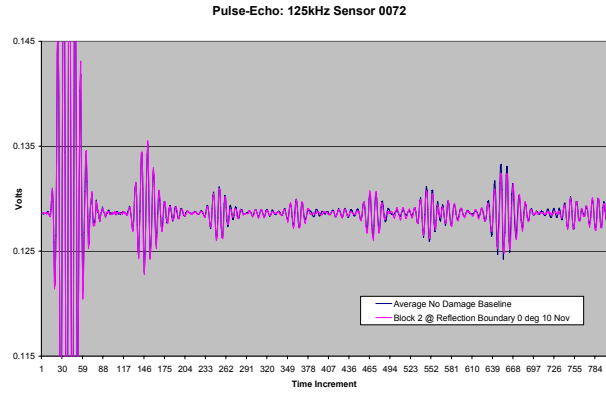
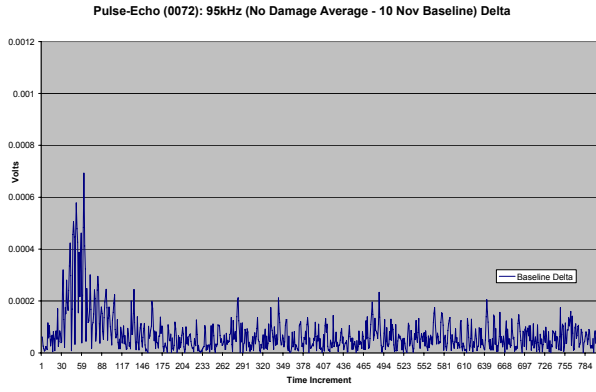

Pulse-Echo (Sensor 0072): 10 Nov 06, Block 8 @ 6" and 0°, No Damage Baseline

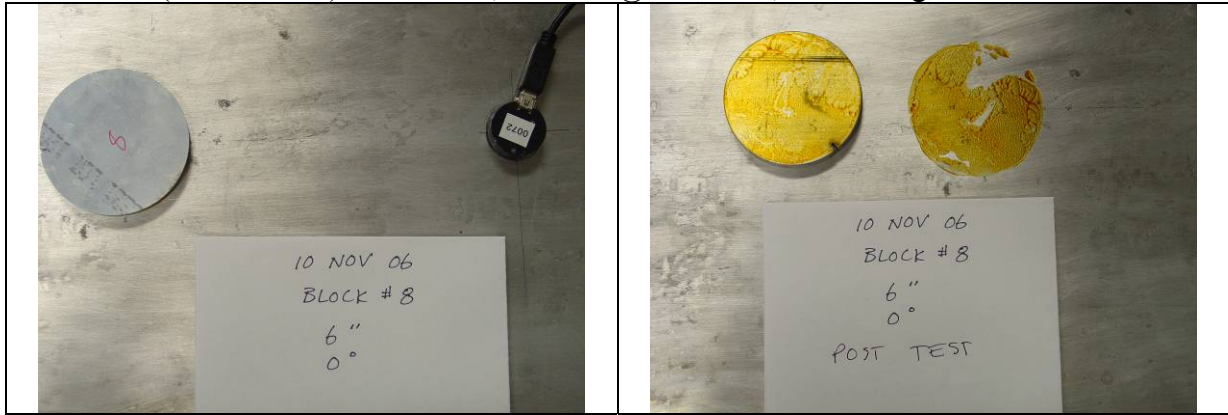

Pulse-Echo: 35 kHz Sensor 0072

Pulse-Echo (0072): 35kHz (No Damage Average - 10 Nov Block 8) Delta

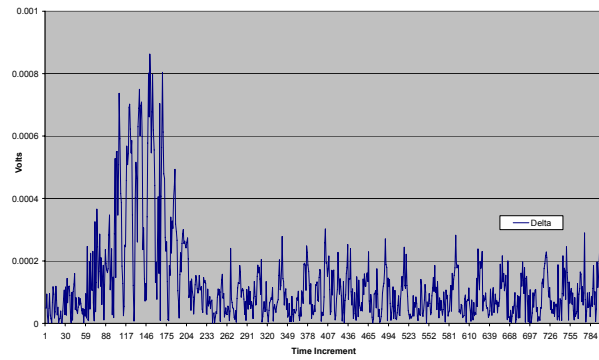
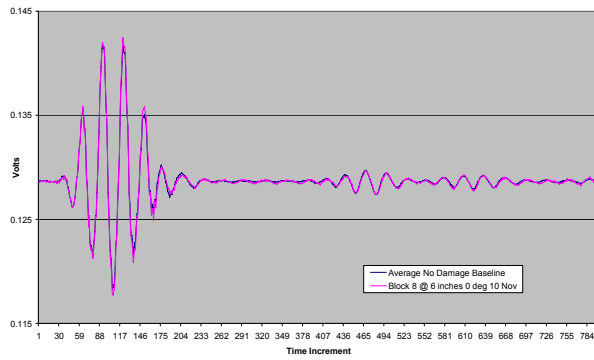

Pulse-Echo (0072): 35kHz (No Damage Average - 10 Nov Baseline) Delta

Pulse-Echo: 65kHz Sensor 0072

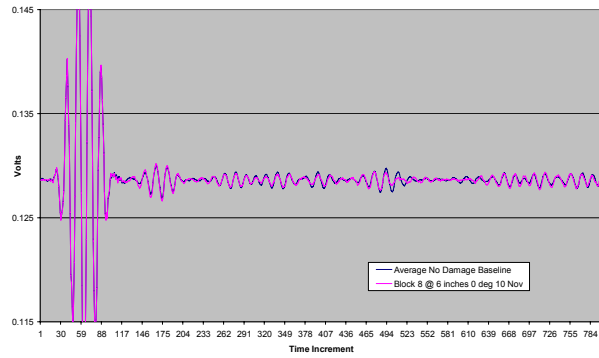
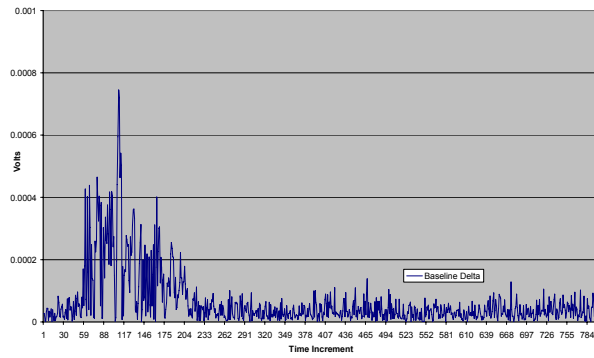

Pulse-Echo (0072): 65kHz (No Damage Average - 10 Nov Block 8) Delta

Pulse-Echo (0072): 65kHz (No Damage Average - 10 Nov Baseline) Delta

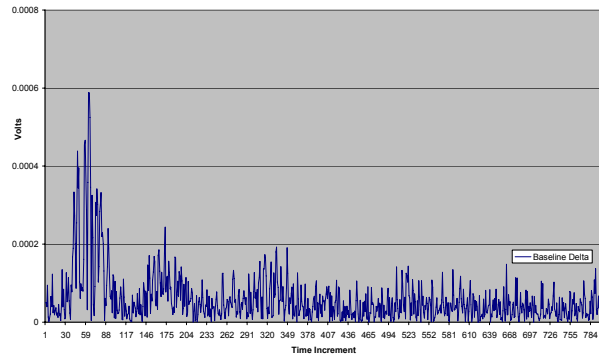
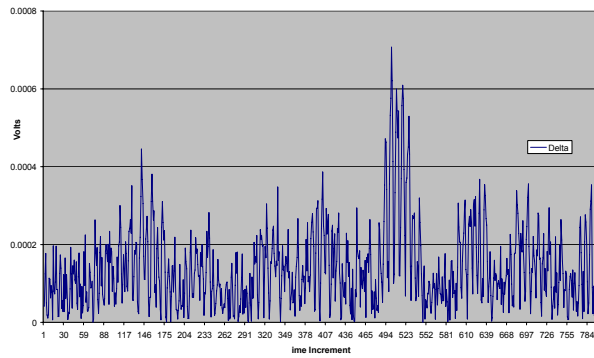

Pulse-Echo: 95kHz Sensor 0072

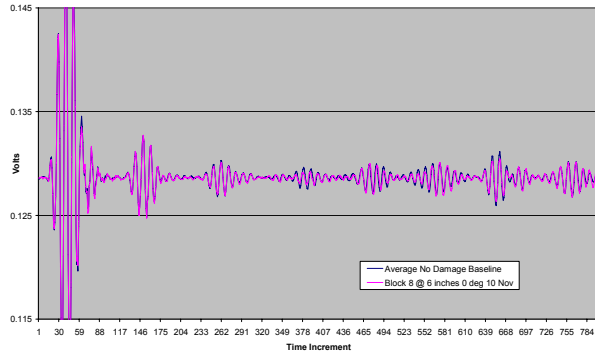

Pulse-Echo (0072): 95kHz (No Damage Average - 10 Nov Block 8) Delta

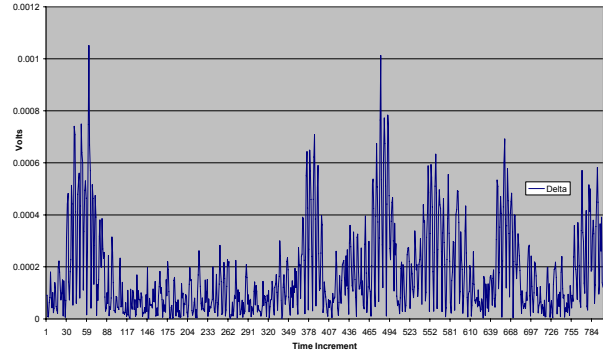

Pulse-Echo (0072): 95kHz (No Damage Average - 10 Nov Baseline) Delta

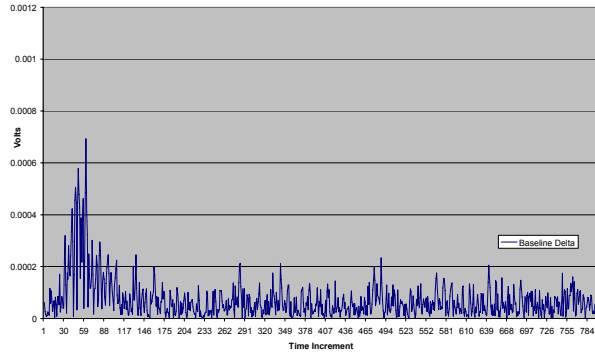

Pulse-Echo: 125kHz Sensor 0072

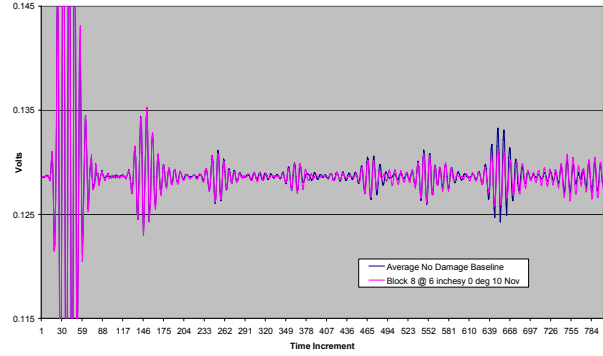

Pulse-Echo (0072): 125kHz (No Damage Average - 10 Nov Block 8) Delta

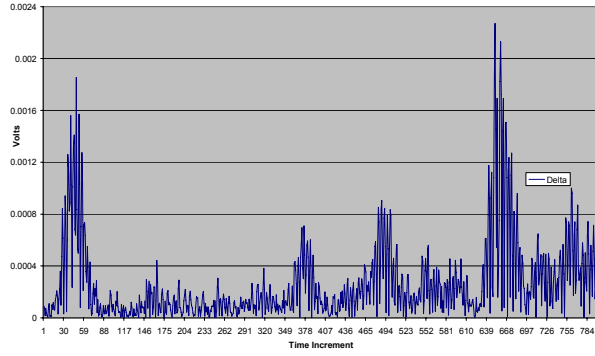

Pulse-Echo (0072): 125kHz (No Damage Average - 10 Nov Baseline) Delta

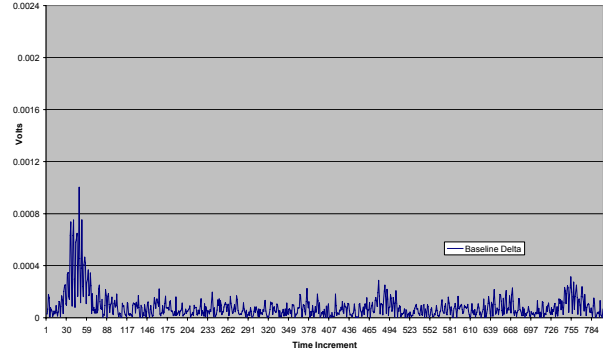

Pulse-Echo: 155kHz Sensor 0072

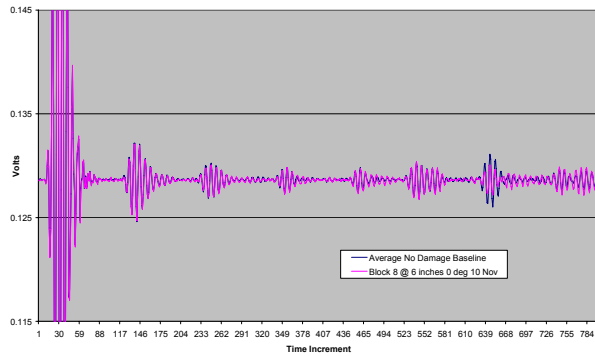

Pulse-Echo (0072): 155kHz (No Damage Average - 10 Nov Block 8) Delta

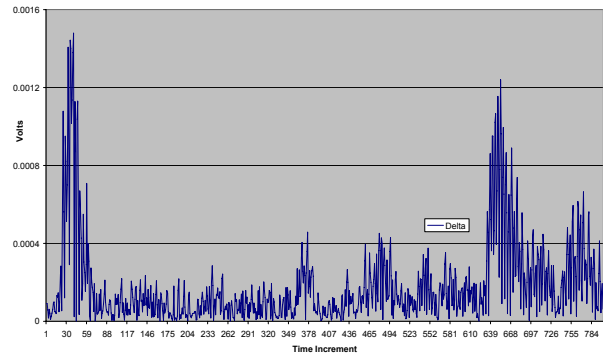

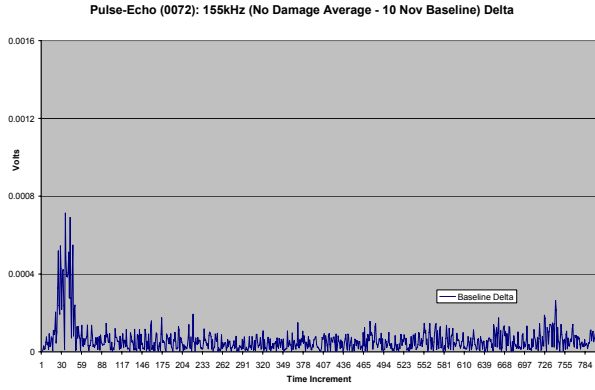

Pulse-Echo (Sensor 0072): 10 Nov 06, Block 2 @ 6" and 0°, Block 1 @ 16" and 0°
 No Damage Baseline

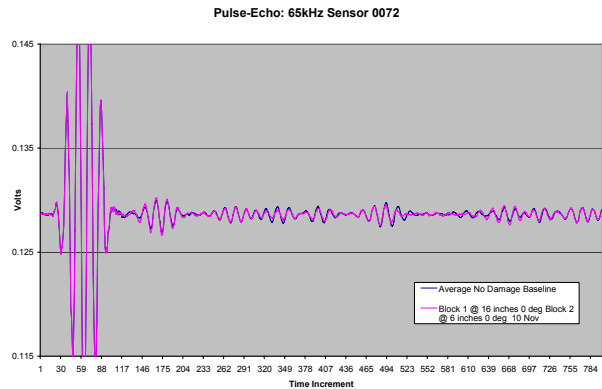
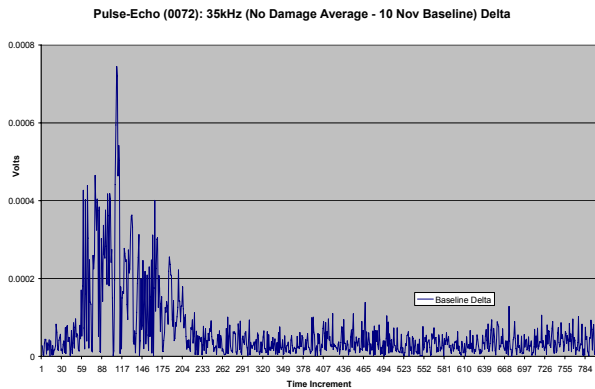
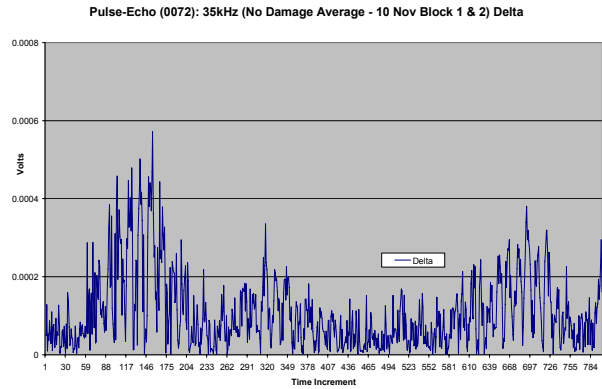
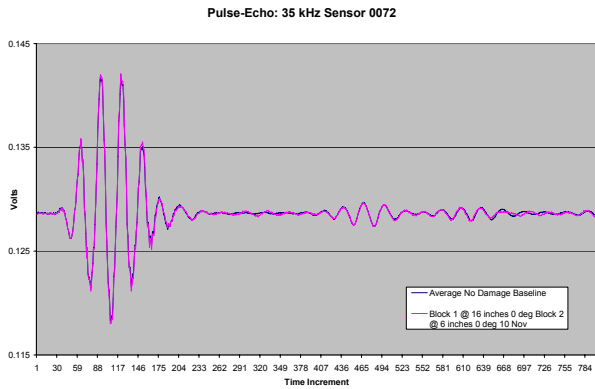
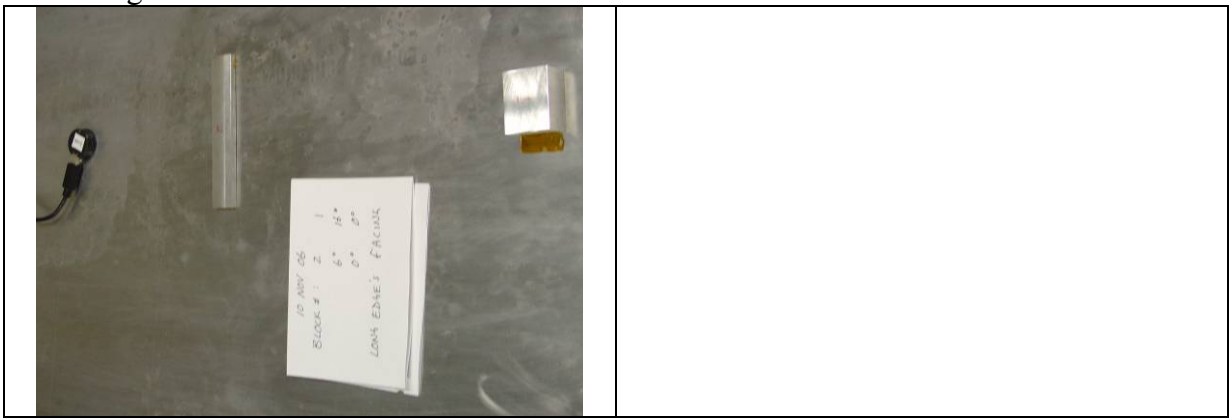

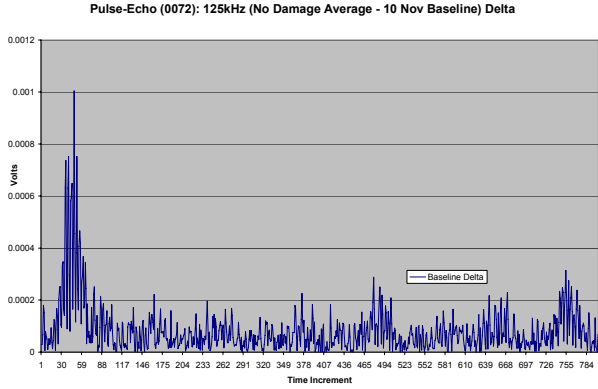
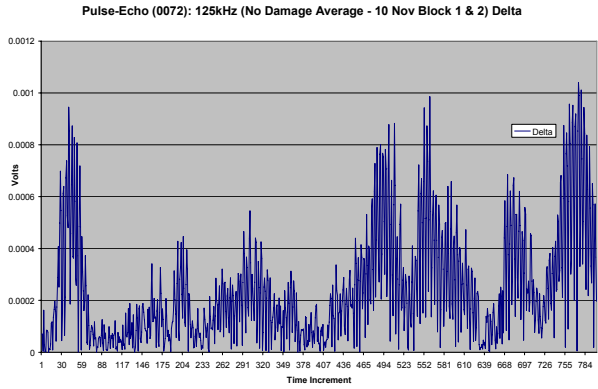
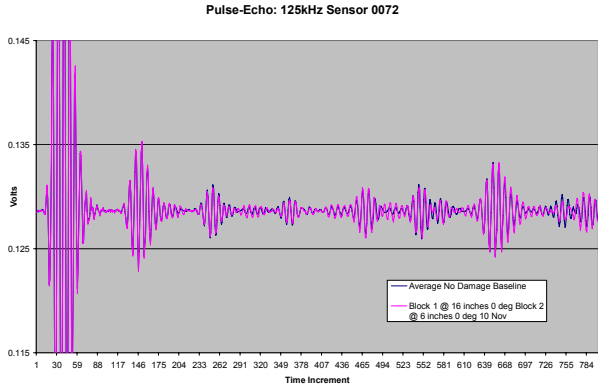
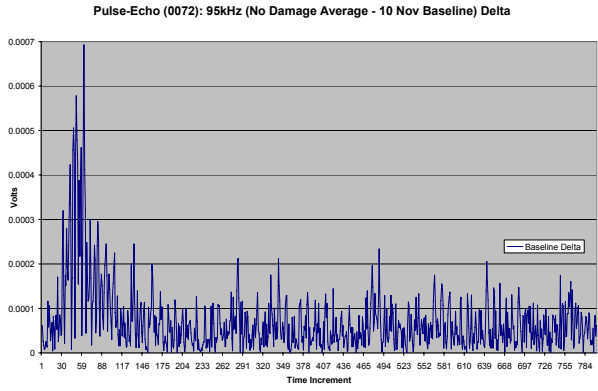
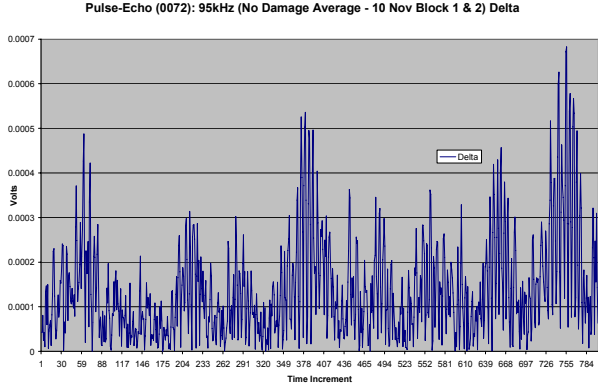
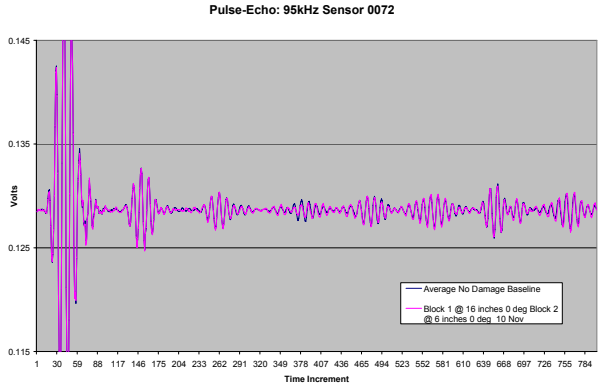
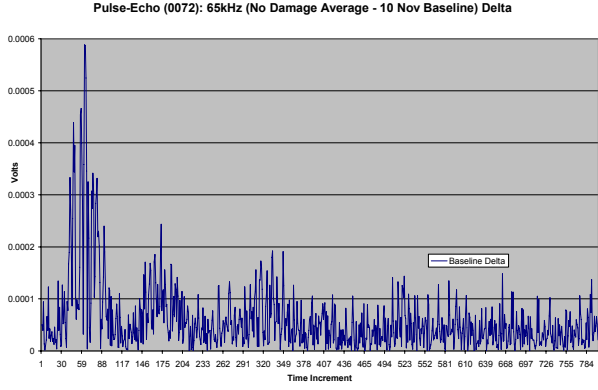
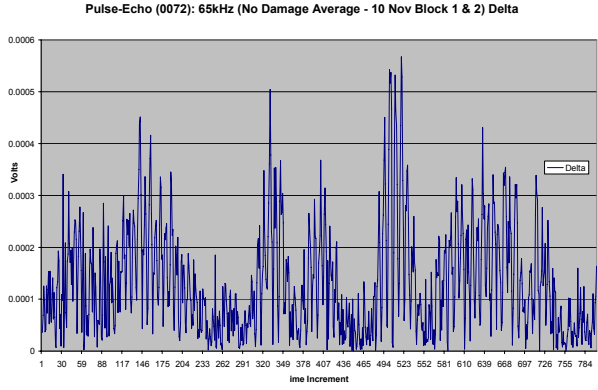

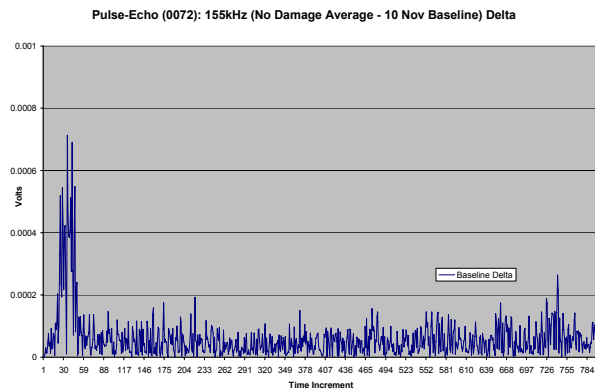
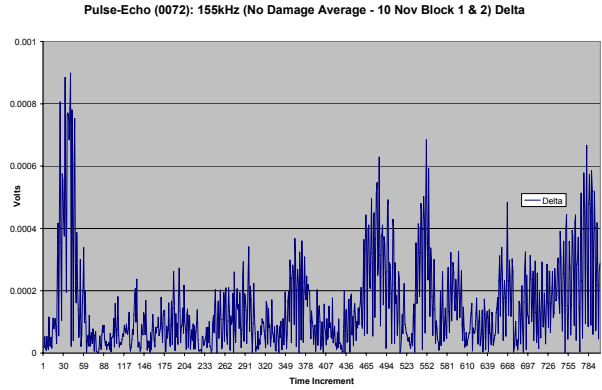
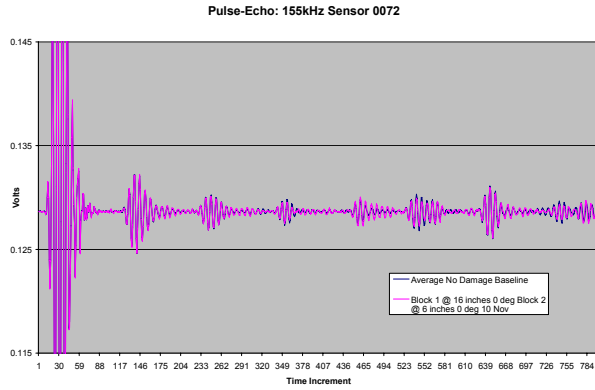

Pulse-Echo (Sensor 0072): 10 Nov 06, Block 2 @ 6" and 90°, Block 1 @ 16" and 0°
No Damage Baseline

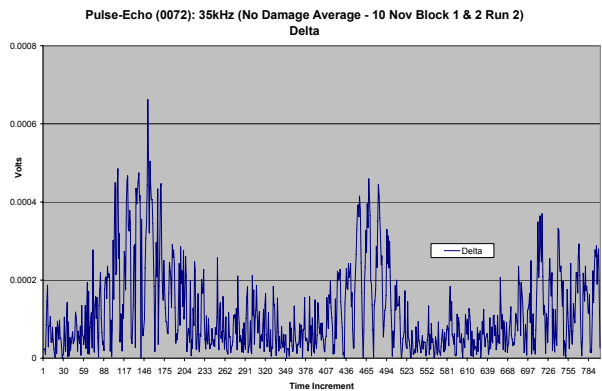
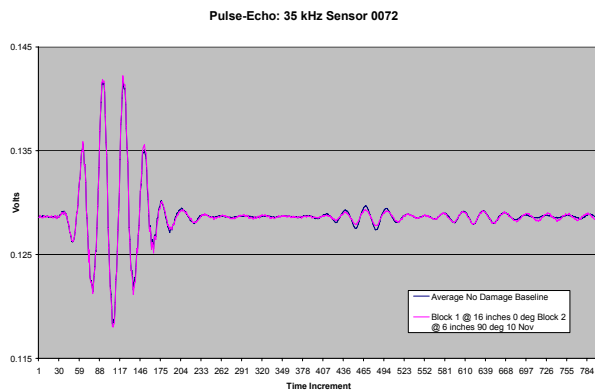

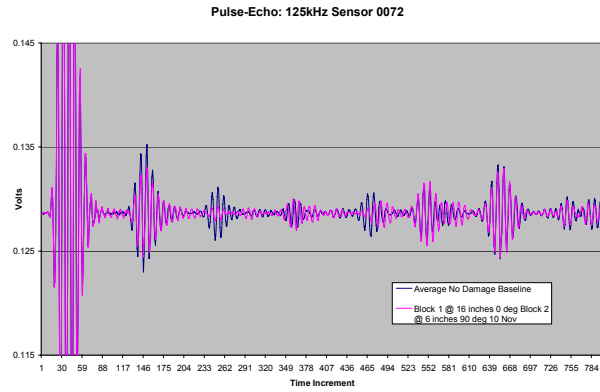
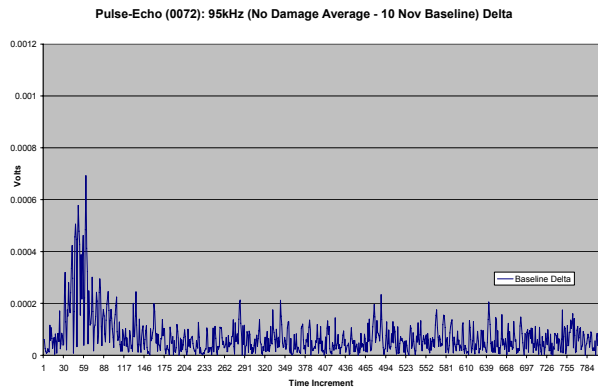
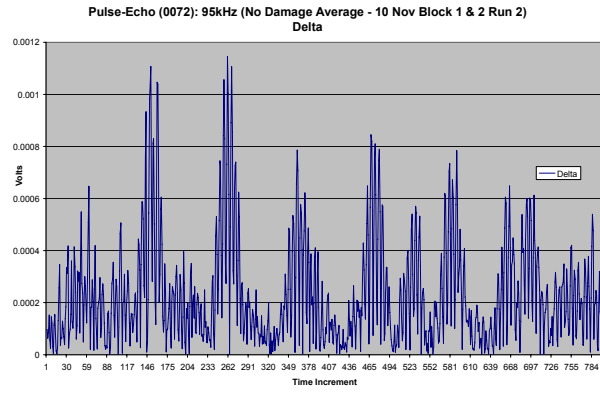
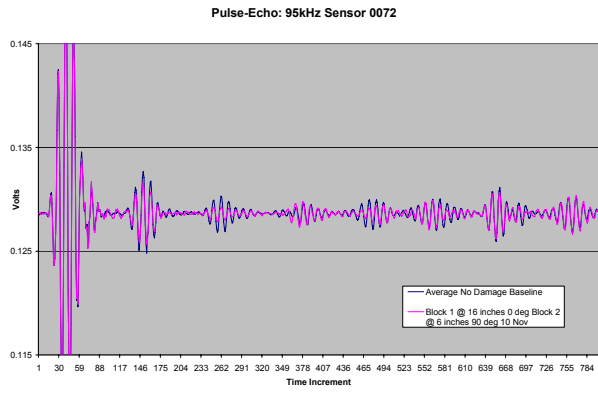
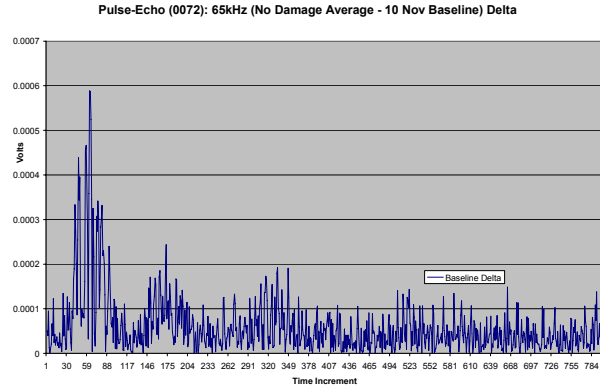
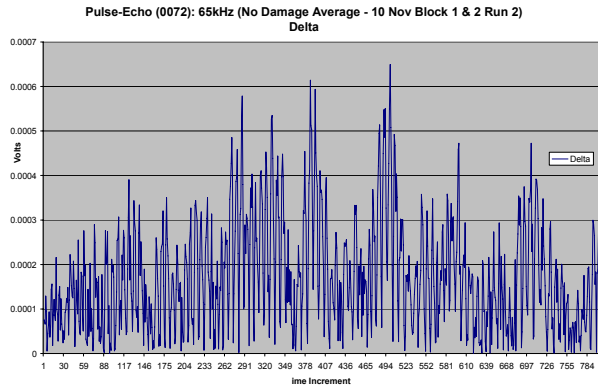
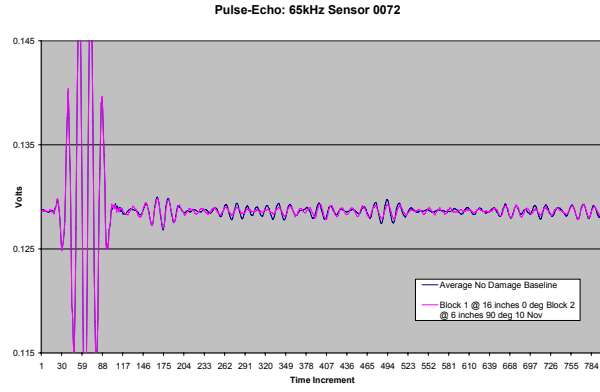
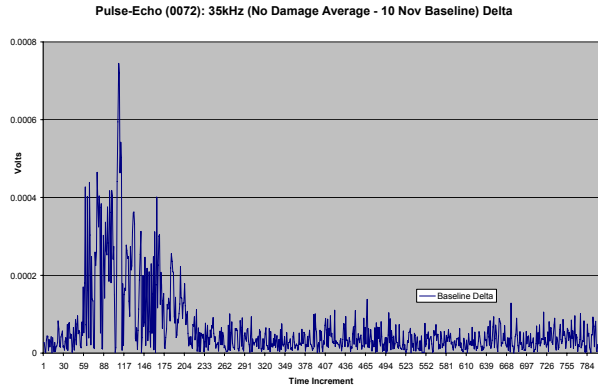

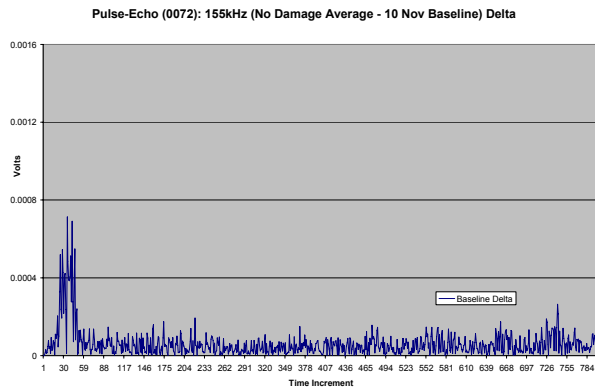
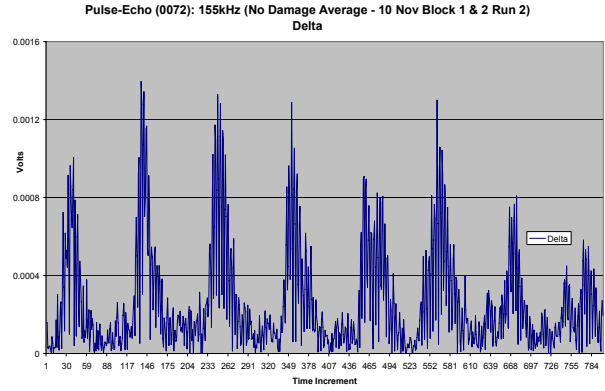
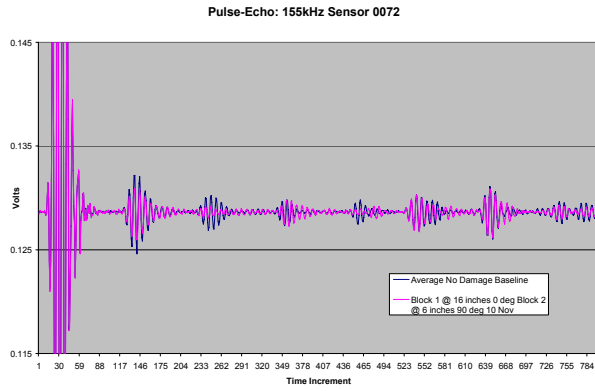
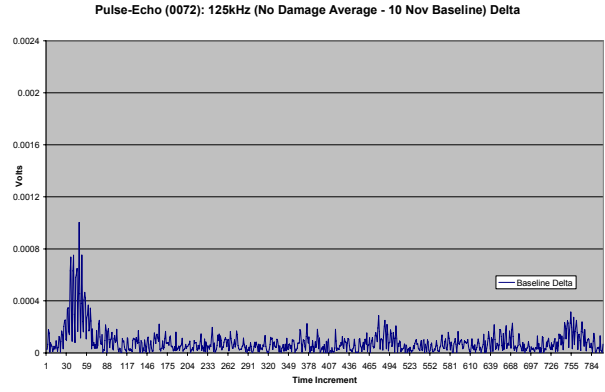
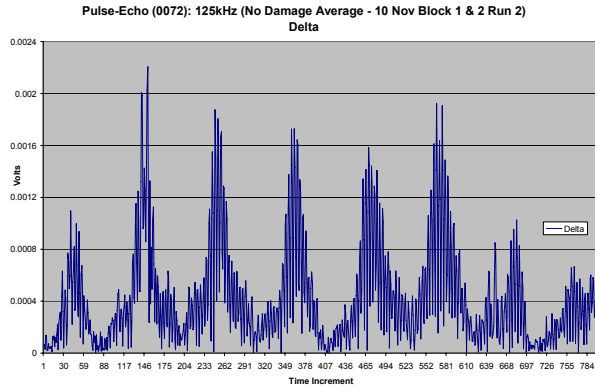

Pulse-Echo (Sensor 0072): 16 Nov 06, Block 1 @ 165mm and 0°, No Damage Baseline



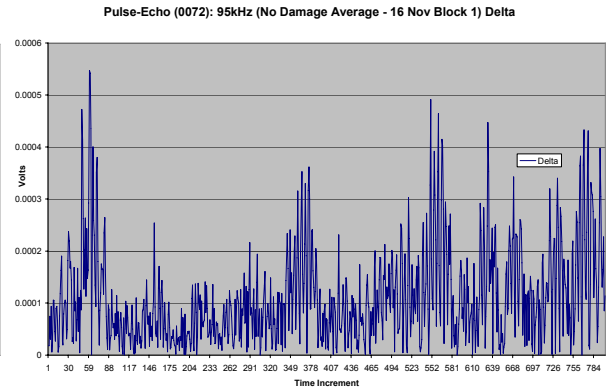
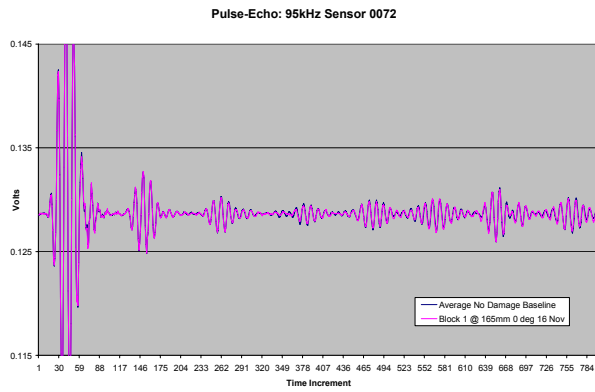
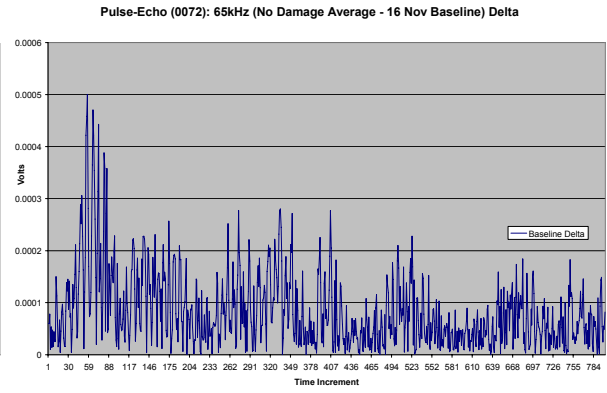
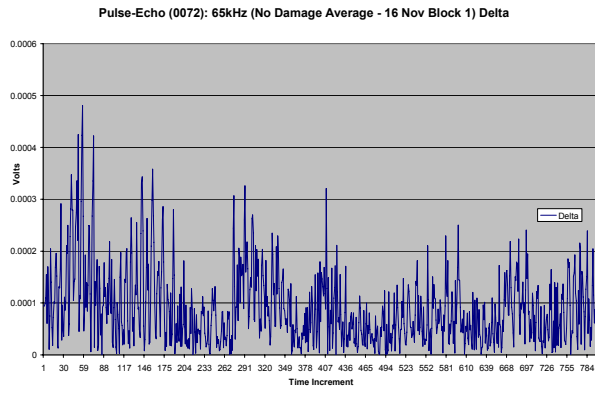
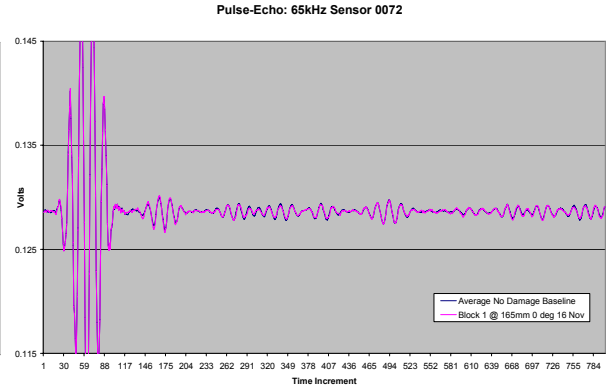
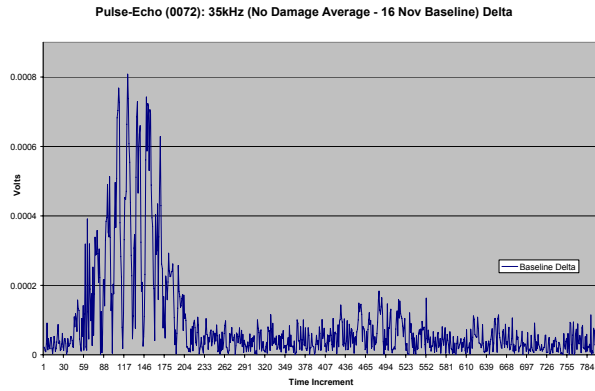
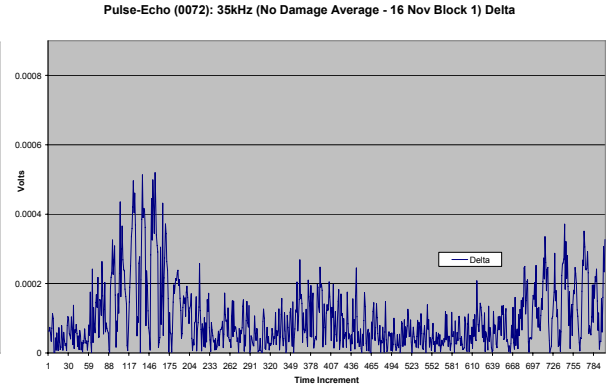
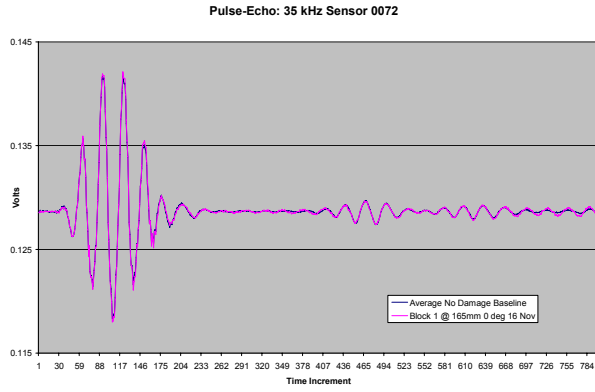

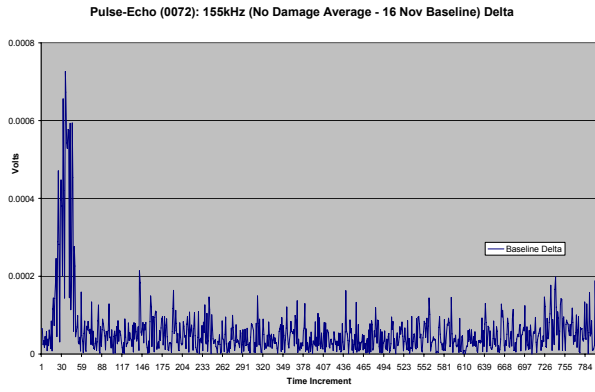
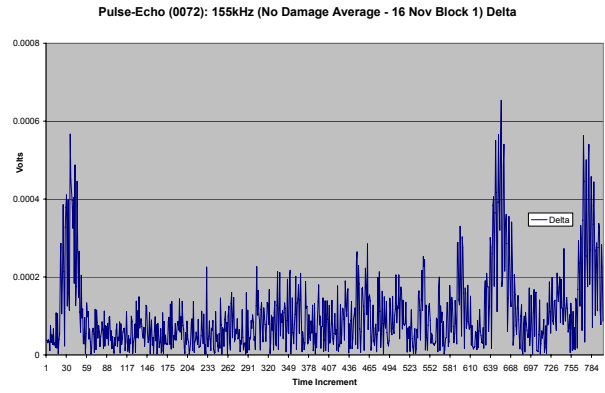
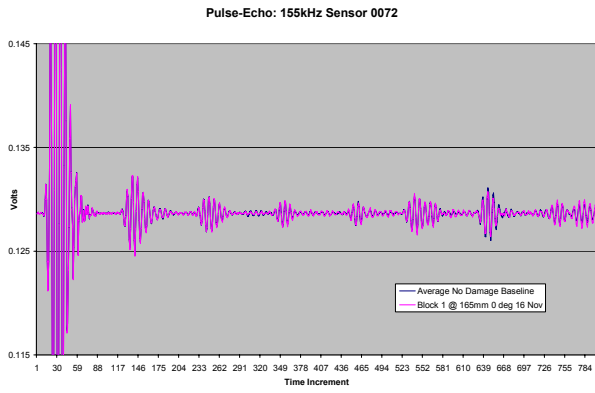
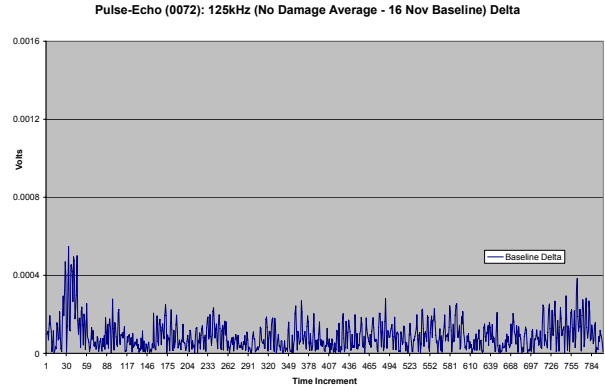
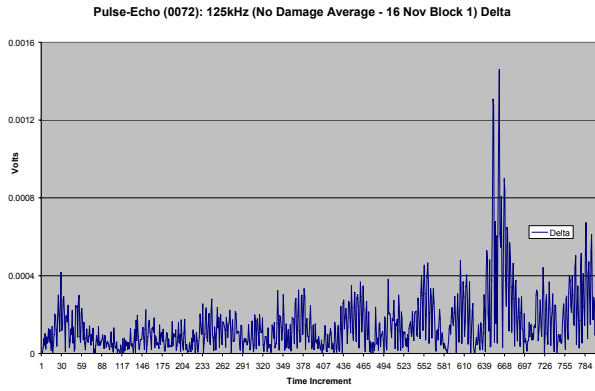
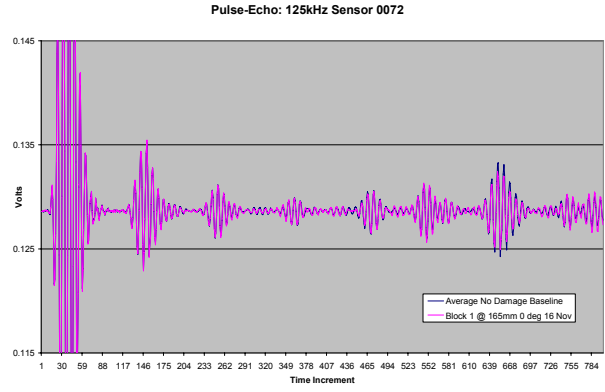
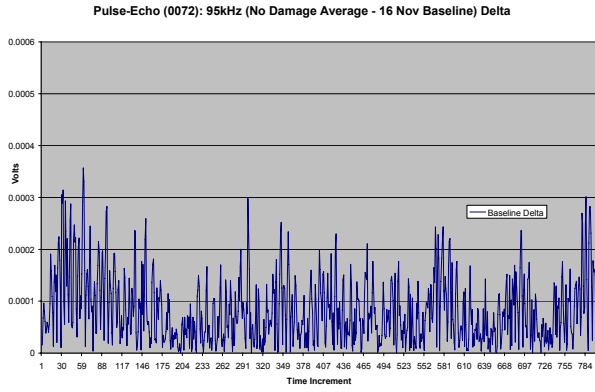

Pulse-Echo (Sensor 0072): 16 Nov 06, Block 2 @ 165mm and 0°, No Damage Baseline



Pulse-Echo: 35 kHz Sensor 0072

Pulse-Echo (0072): 35kHz (No Damage Average - 16 Nov Block 2) Delta

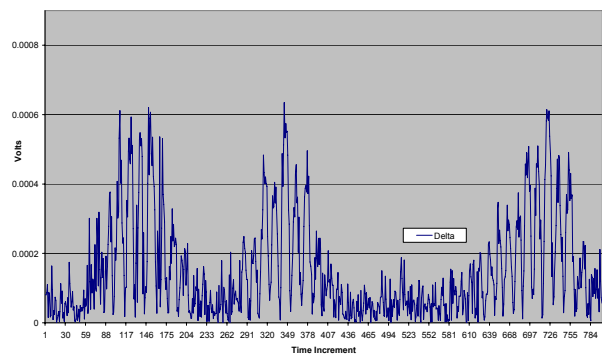
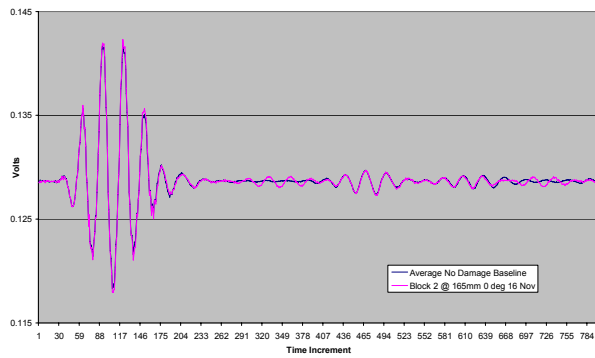

Pulse-Echo (0072): 35kHz (No Damage Average - 16 Nov Baseline) Delta

Pulse-Echo: 65kHz Sensor 0072

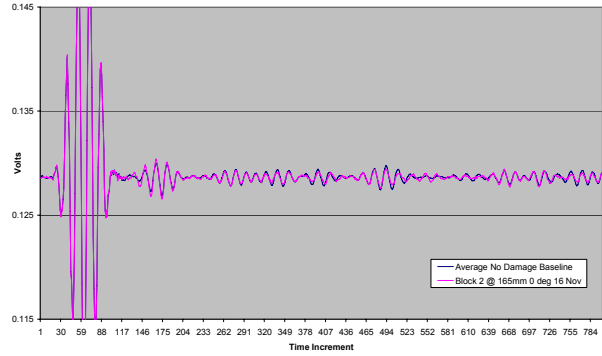
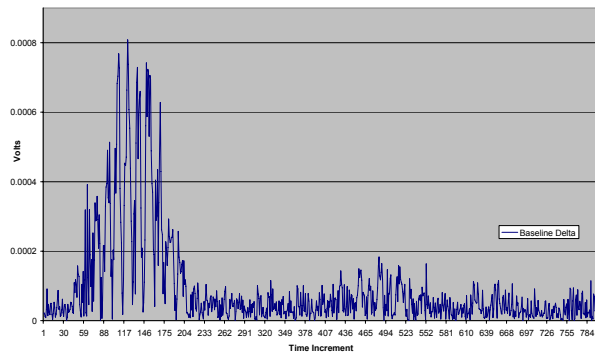

Pulse-Echo (0072): 65kHz (No Damage Average - 16 Nov Block 2) Delta

Pulse-Echo (0072): 65kHz (No Damage Average - 16 Nov Baseline) Delta

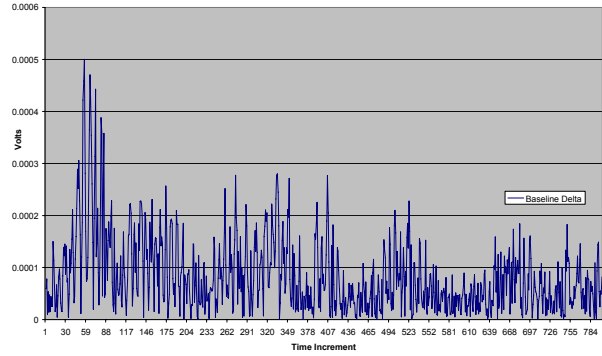
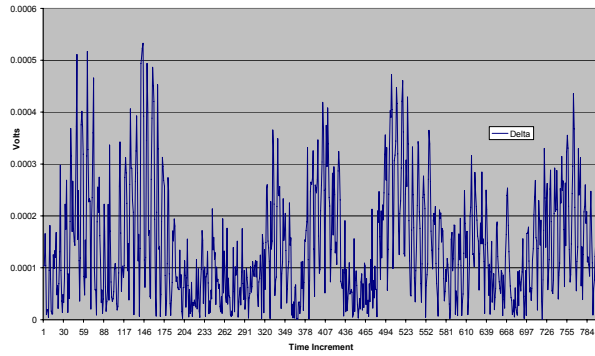

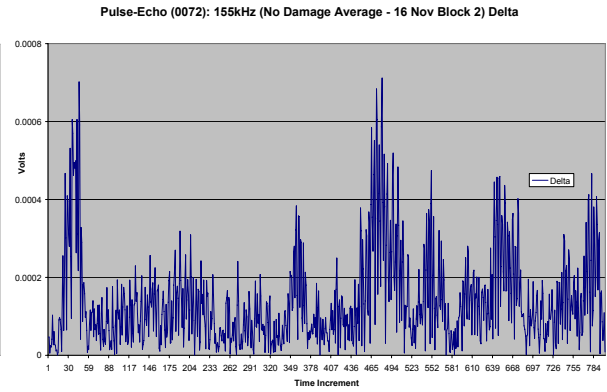
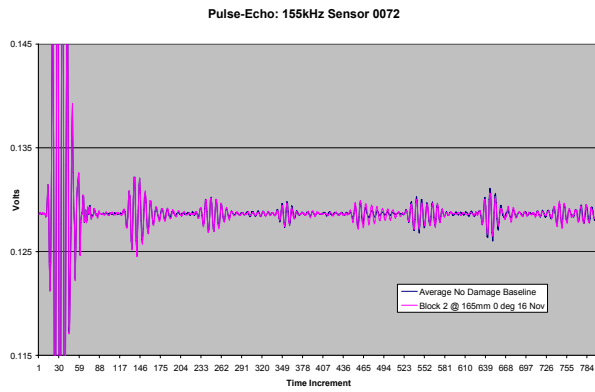
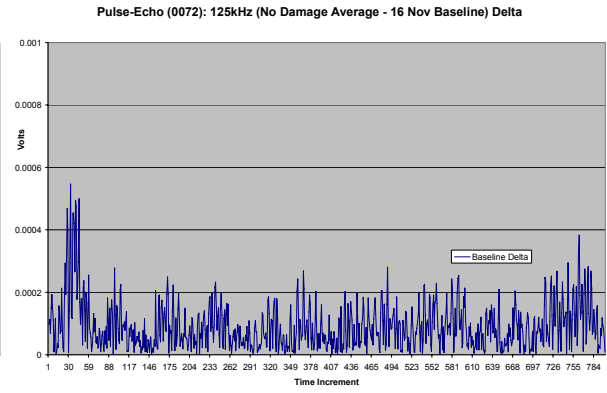
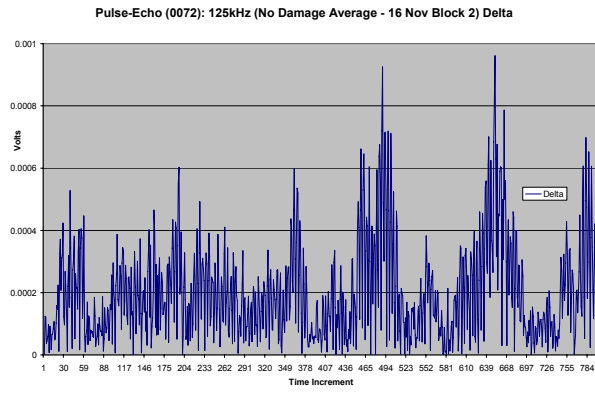
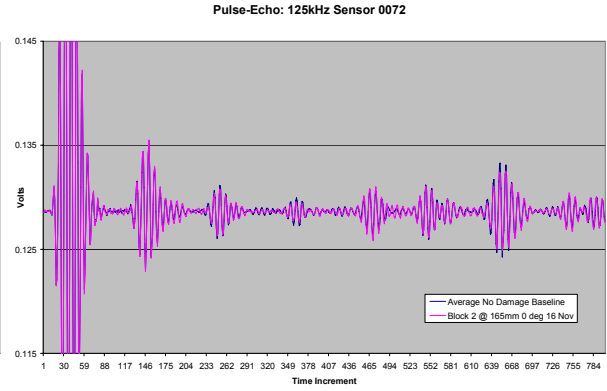
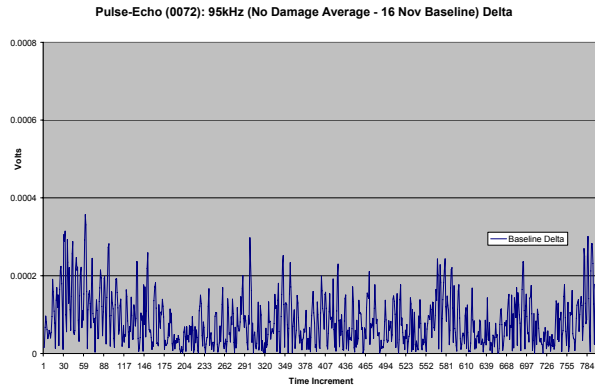
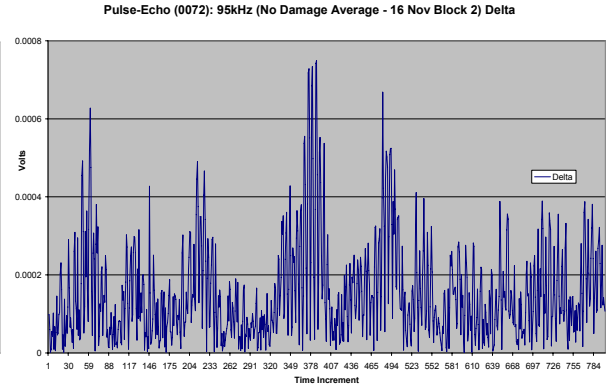
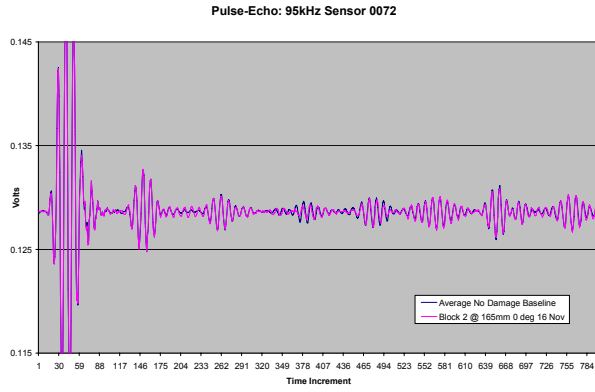

Pulse-Echo (0072): 155kHz (No Damage Average - 16 Nov Baseline) Delta

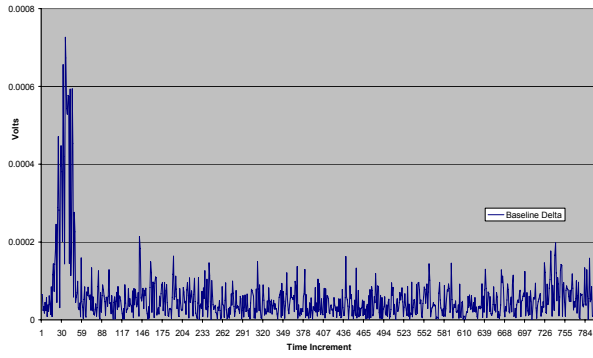

Pulse-Echo (Sensor 0072): 16 Nov 06, Block 2 @ 433mm and 0°, No Damage Baseline

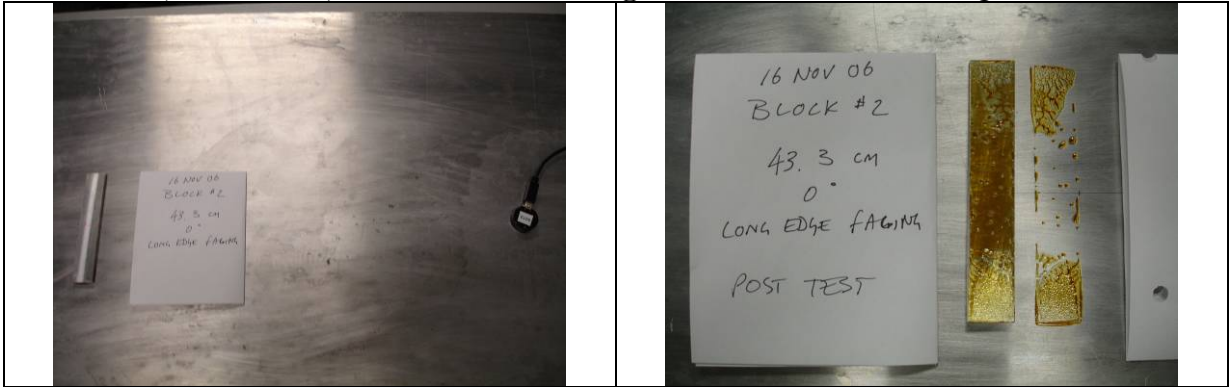

Pulse-Echo: 35 kHz Sensor 0072

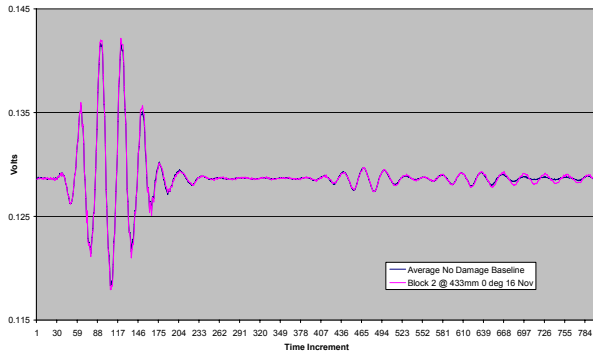

Pulse-Echo (0072): 35kHz (No Damage Average - 16 Nov Block 2 Run 2) Delta

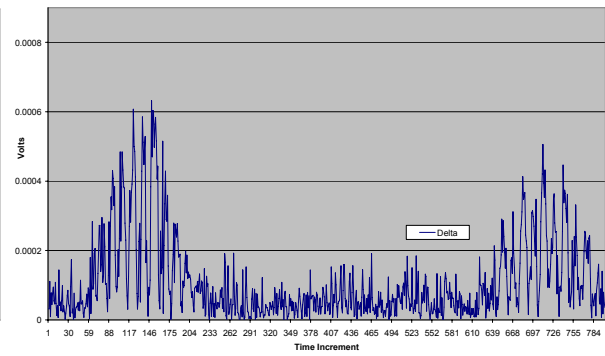

Pulse-Echo (0072): 35kHz (No Damage Average - 16 Nov Baseline) Delta

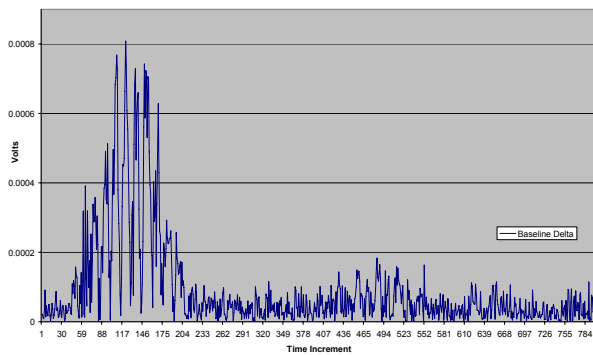

Pulse-Echo: 65kHz Sensor 0072

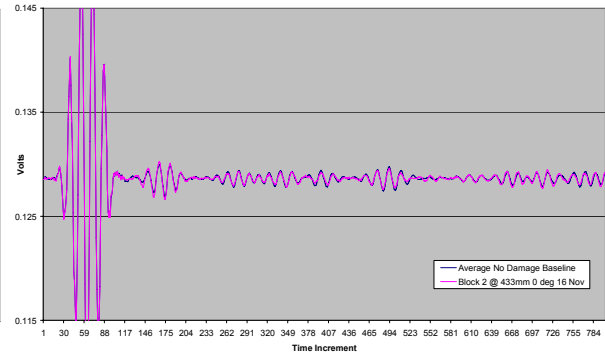

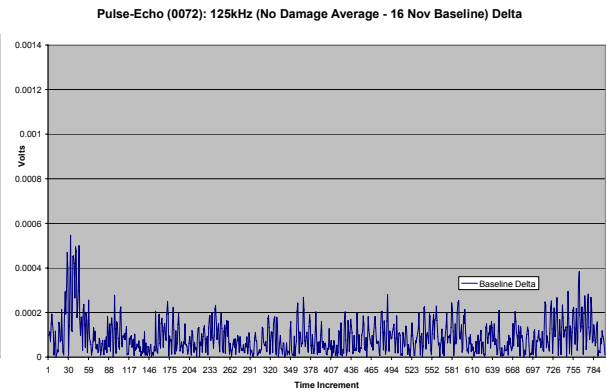
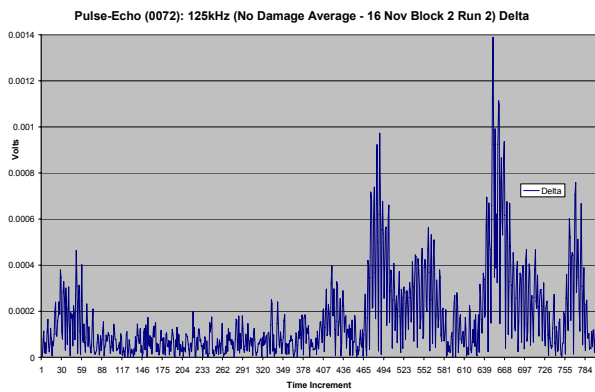
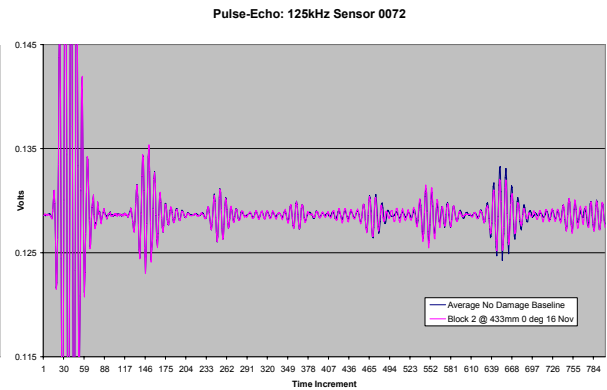
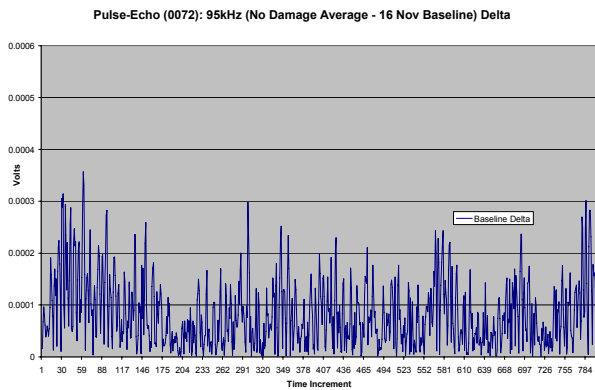
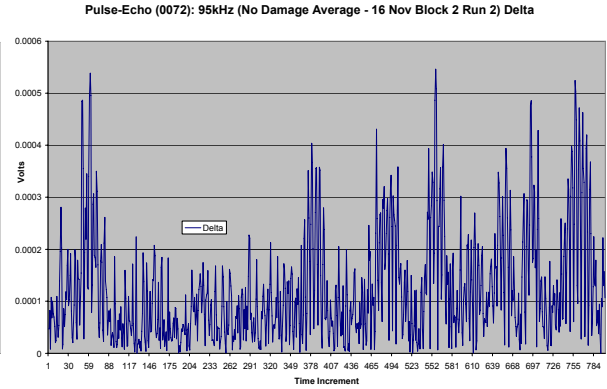
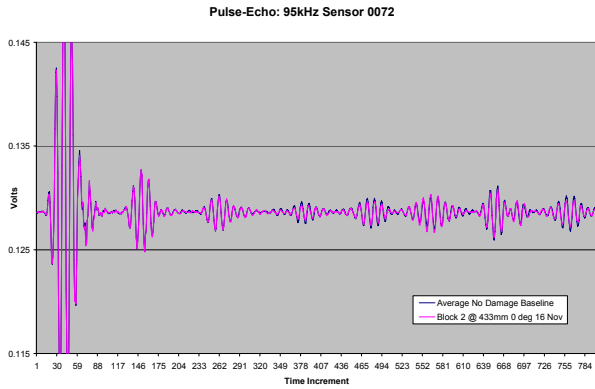
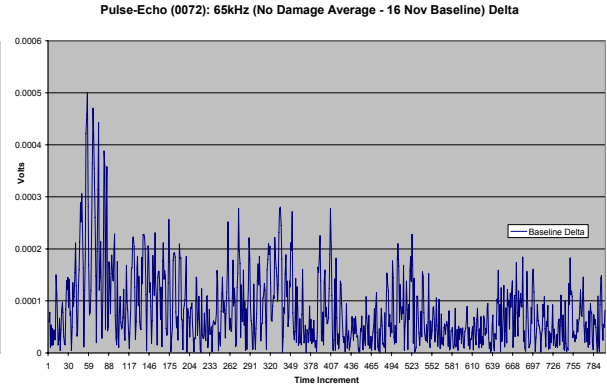
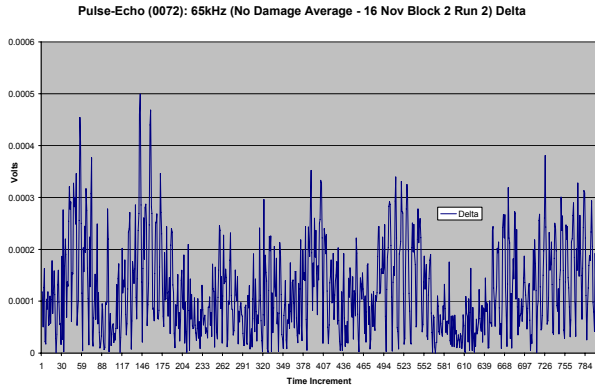

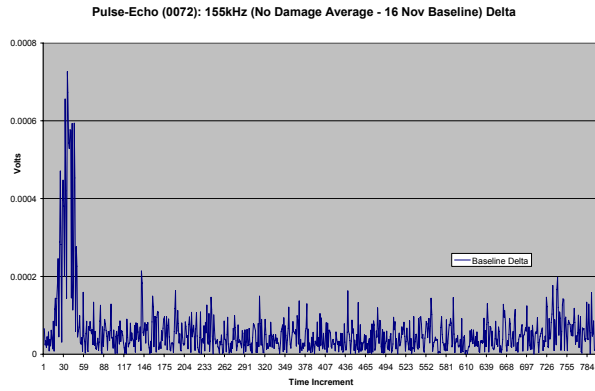
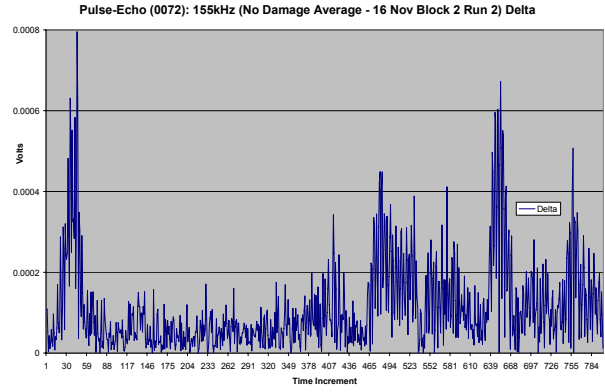
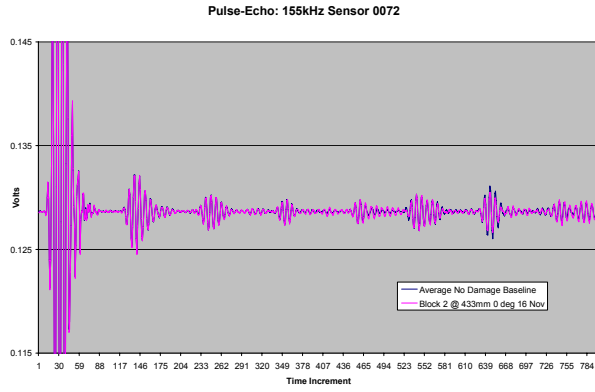

Pulse-Echo (Sensor 0072): 16 Nov 06, Block 1 @ 165mm and 0°, Block 2 @ 433mm and 0°
No Damage Baseline

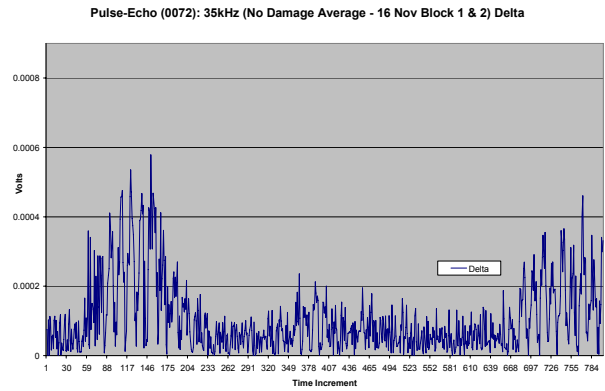
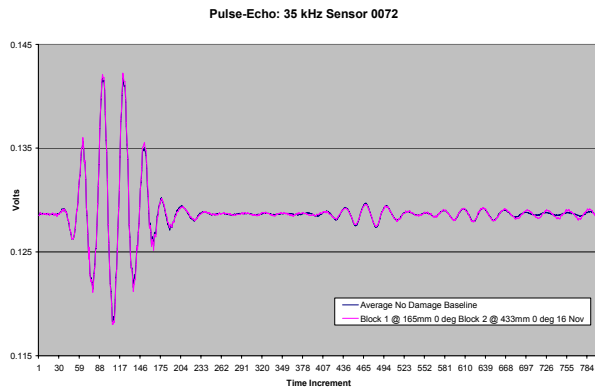

Pulse-Echo (0072): 35kHz (No Damage Average - 16 Nov Baseline) Delta

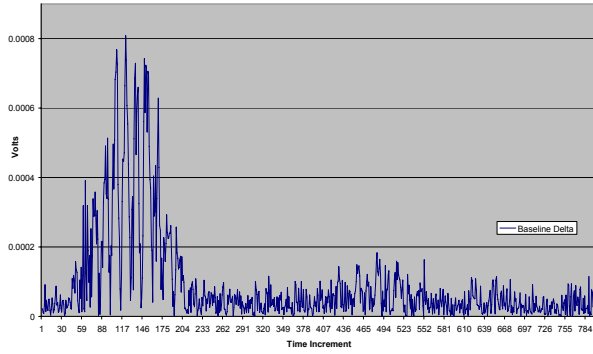

Pulse-Echo: 65kHz Sensor 0072

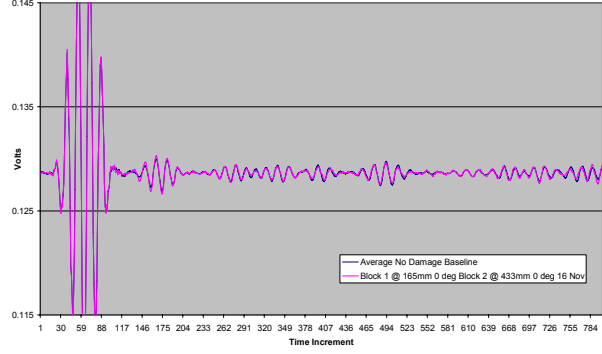

Pulse-Echo (0072): 65kHz (No Damage Average - 16 Nov Block 1 & 2) Delta

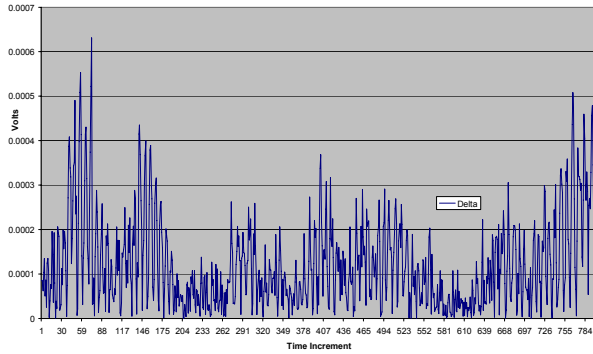

Pulse-Echo (0072): 65kHz (No Damage Average - 16 Nov Baseline) Delta

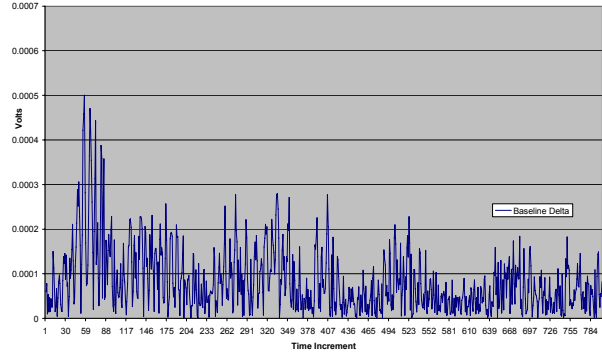

Pulse-Echo: 95kHz Sensor 0072

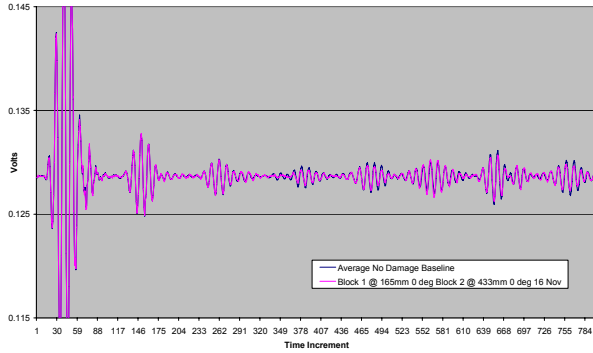

Pulse-Echo (0072): 95kHz (No Damage Average - 16 Nov Block 1 & 2) Delta

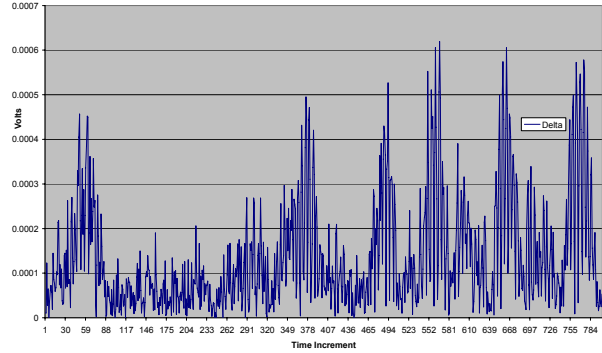

Pulse-Echo (0072): 95kHz (No Damage Average - 16 Nov Baseline) Delta

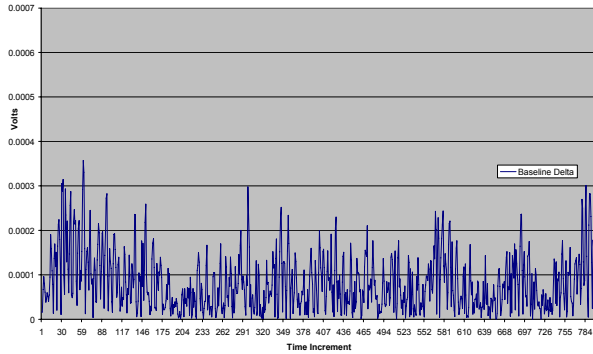

Pulse-Echo: 125kHz Sensor 0072

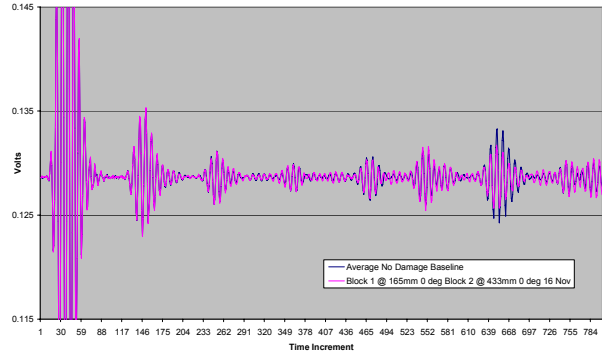

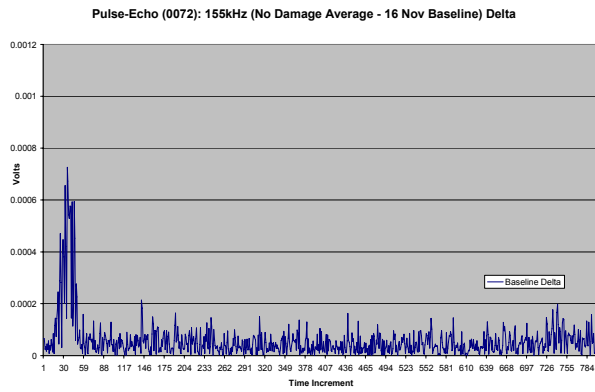
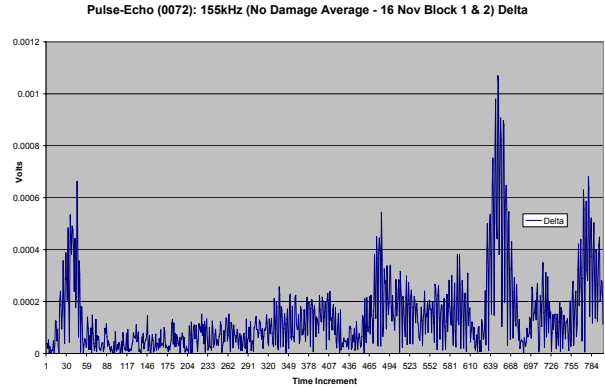
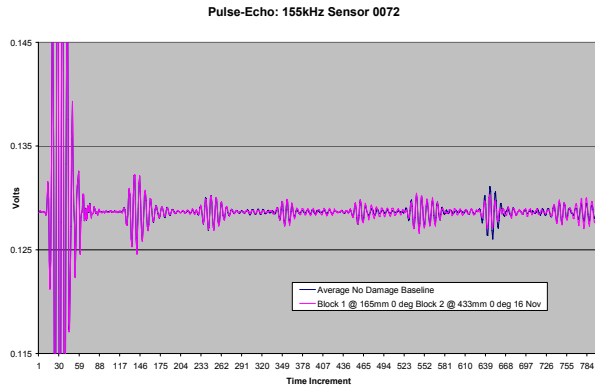
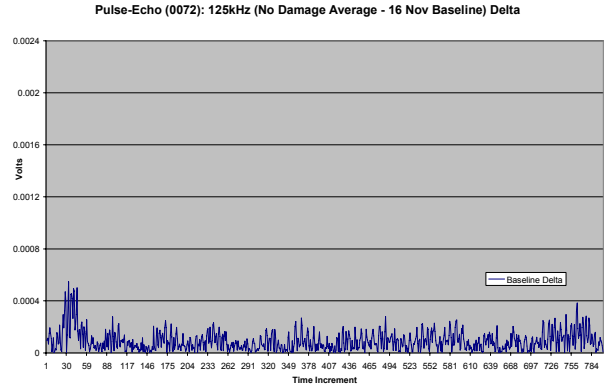
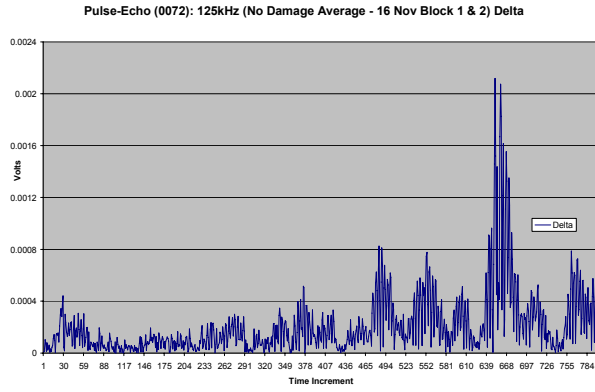

Pulse-Echo (Sensor 0072): 21 Nov 06, Block 2 @ 165mm and 0°, No Damage Baseline

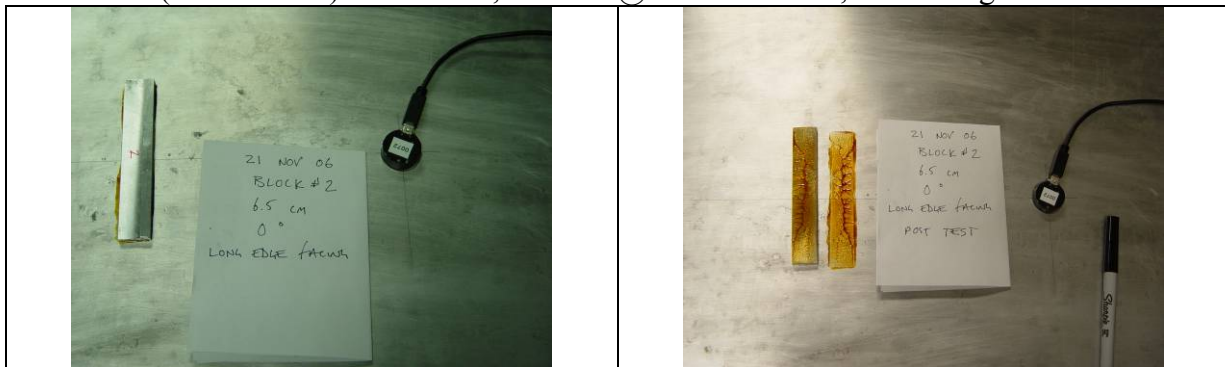

Pulse-Echo: 95kHz Sensor 0072

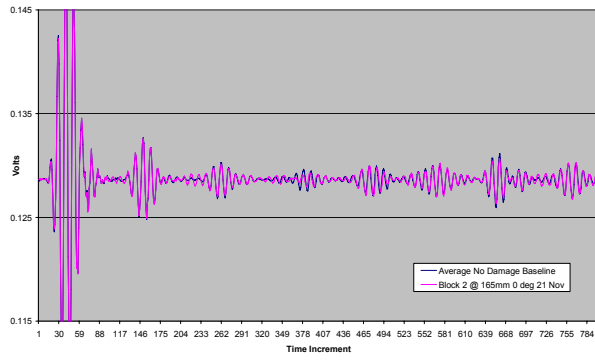

Pulse-Echo (0072): 95kHz (No Damage Average - 21 Nov Block 2) Delta

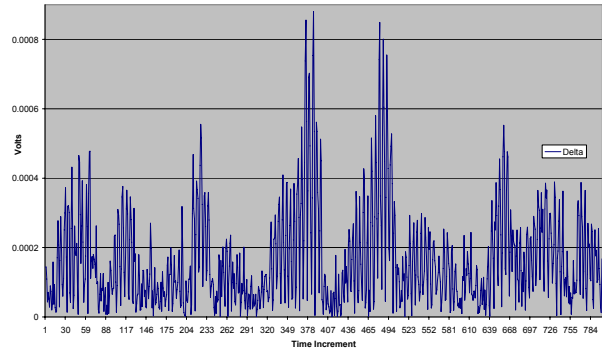

Pulse-Echo (0072): 95kHz (No Damage Average - 21 Nov Baseline) Delta

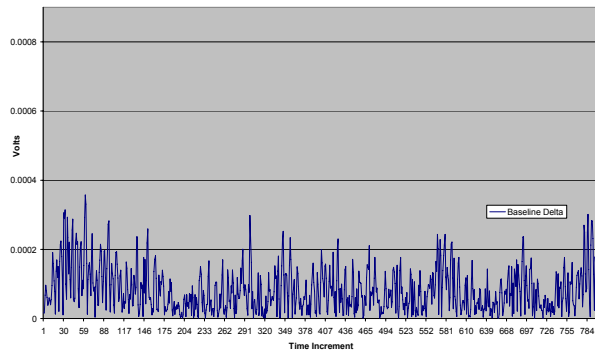

Pulse-Echo: 125kHz Sensor 0072

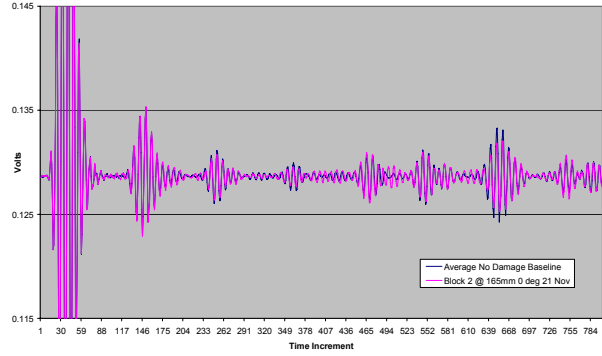

Pulse-Echo (0072): 125kHz (No Damage Average - 21 Nov Block 2) Delta

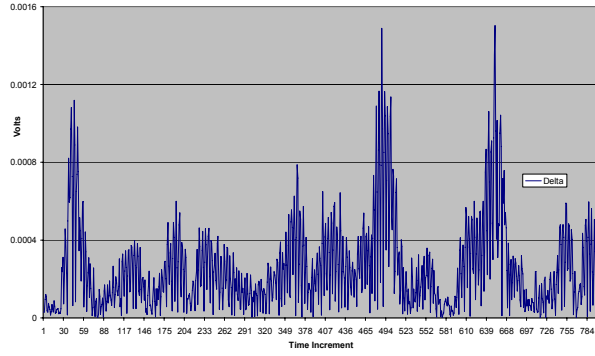

Pulse-Echo (0072): 125kHz (No Damage Average - 21 Nov Baseline) Delta

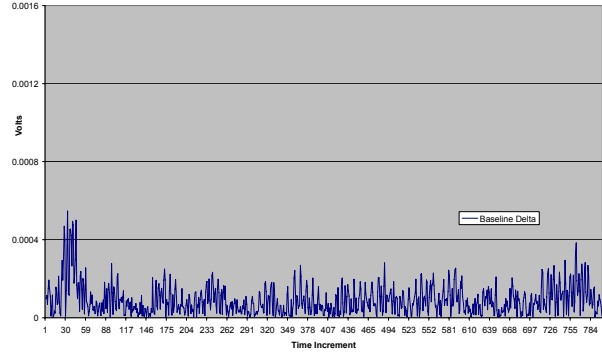

Pulse-Echo: 155kHz Sensor 0072

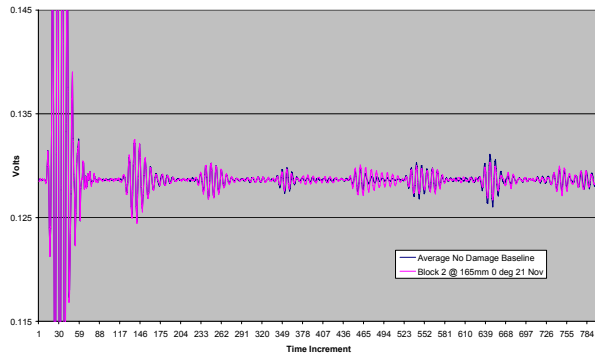

Pulse-Echo (0072): 155kHz (No Damage Average - 21 Nov Block 2) Delta

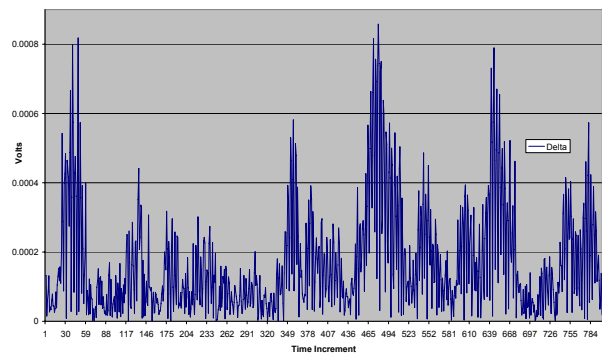

Pulse-Echo (0072): 155kHz (No Damage Average - 21 Nov Baseline) Delta

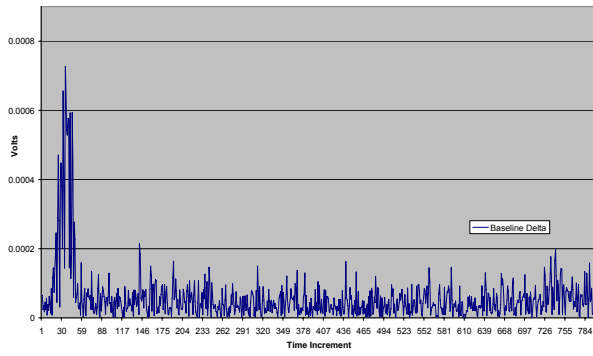

Pulse-Echo (Sensor 0072): 28 Nov 06, Block 10 @ 165mm and 0°, No Damage Baseline



Pulse-Echo: 95kHz Sensor 0072

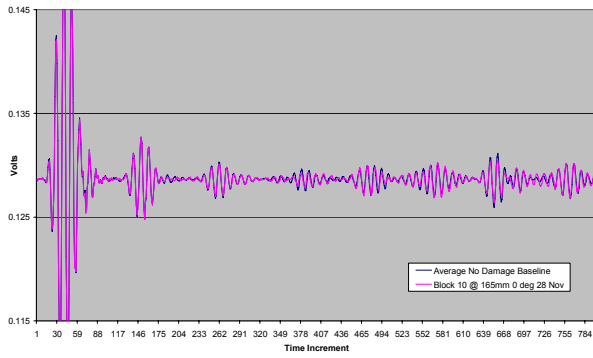

Pulse-Echo (0072): 95kHz (No Damage Average - 28 Nov Block 10) Delta

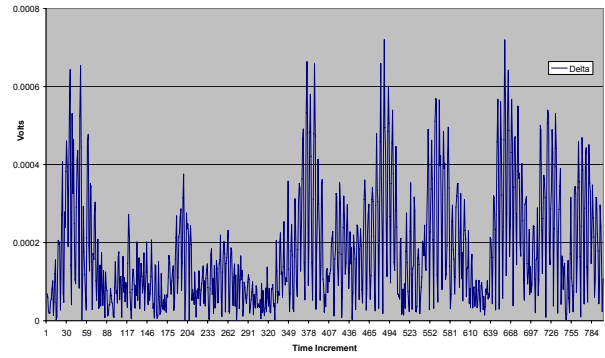

Pulse-Echo (0072): 95kHz (No Damage Average - 28 Nov Baseline) Delta

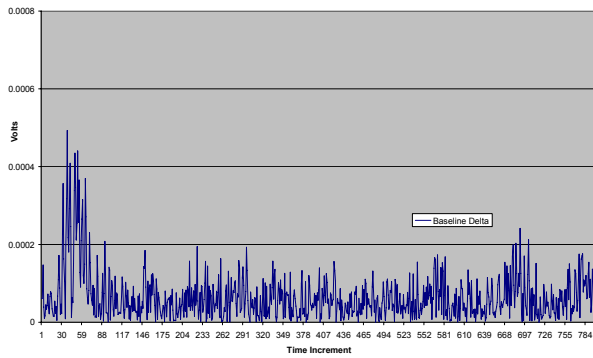

Pulse-Echo: 125kHz Sensor 0072

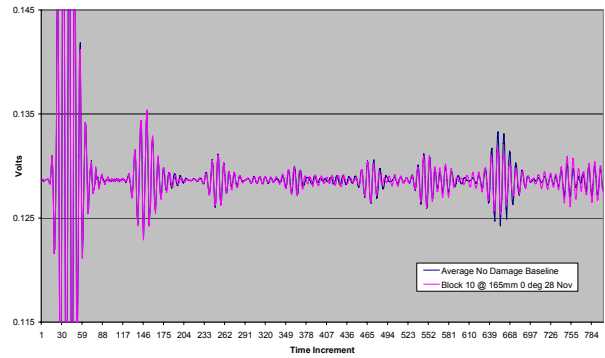

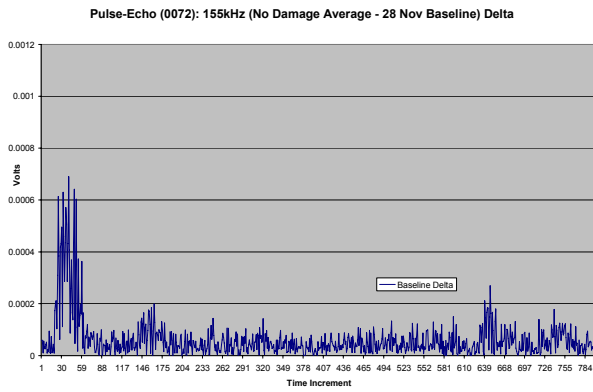
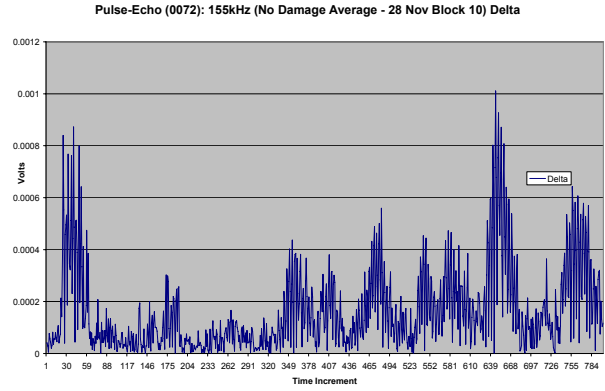
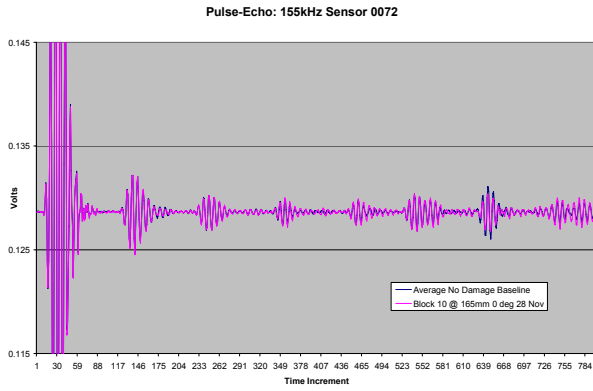
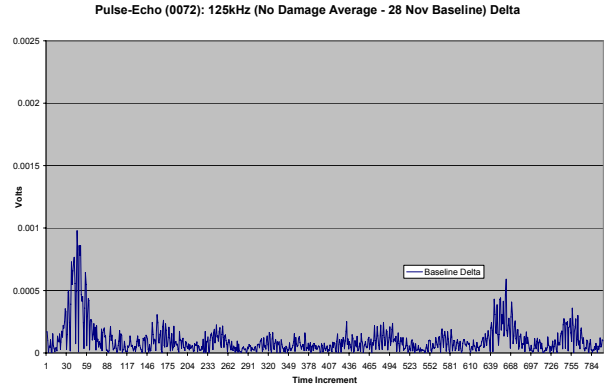
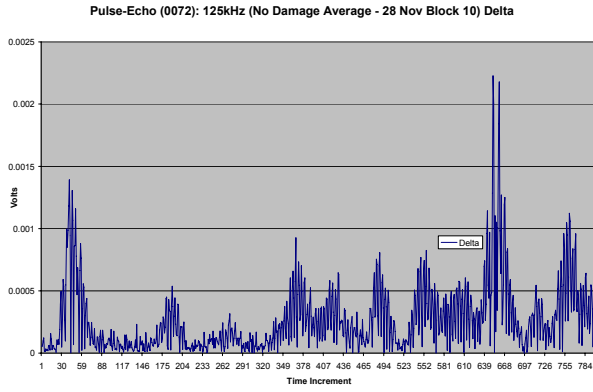

Pulse-Echo (Sensor 0072): 28 Nov 06, Block 10 @ 165mm and 90°, No Damage Baseline

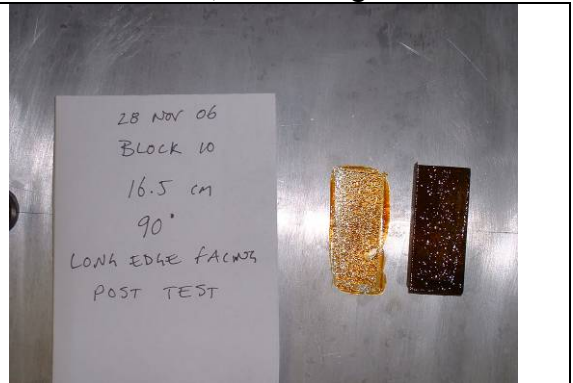
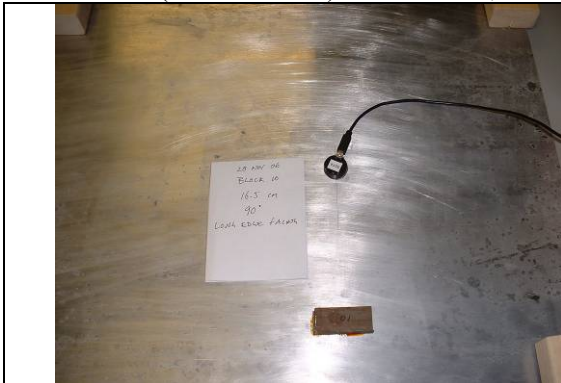

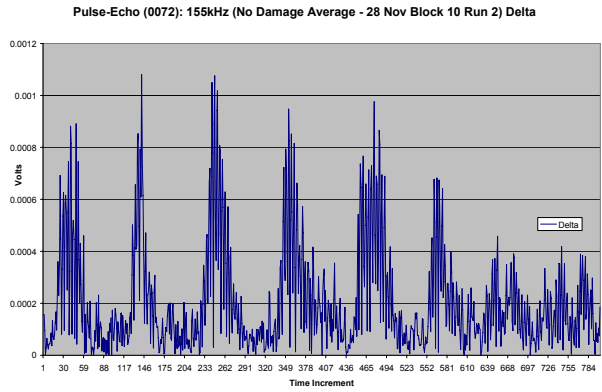
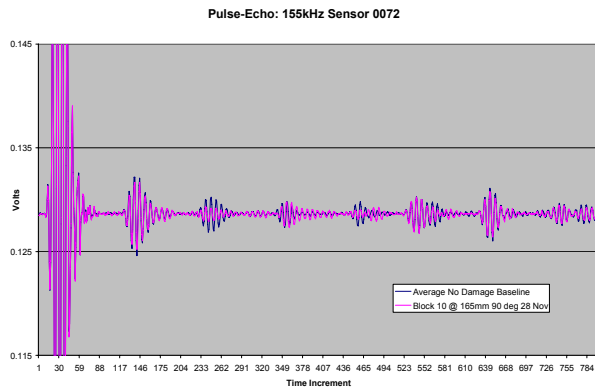
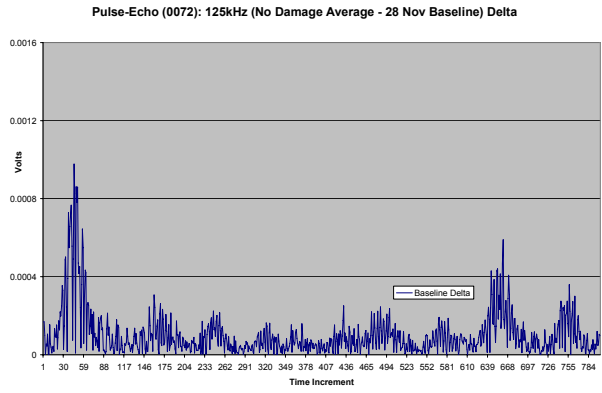
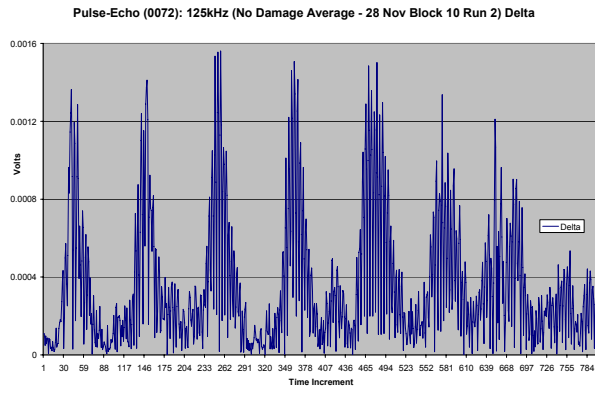
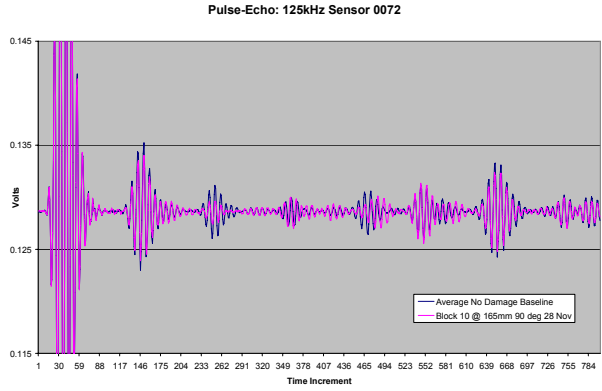
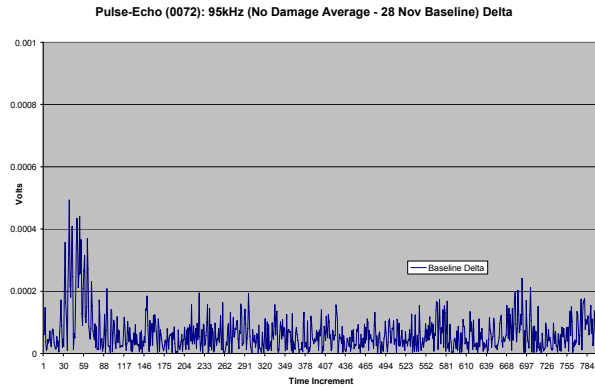
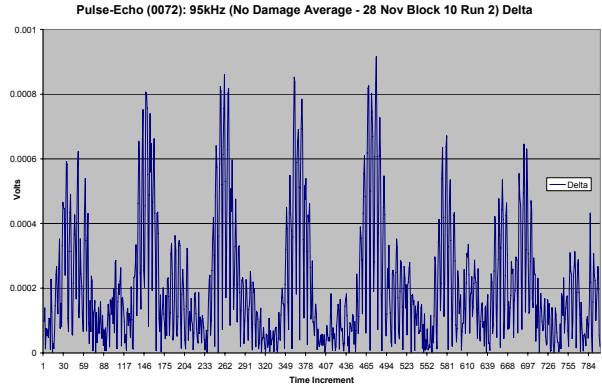
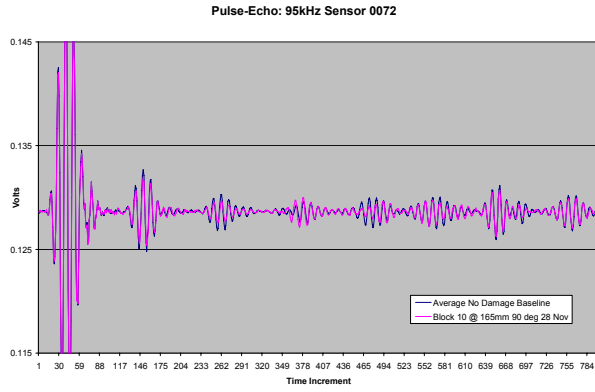

Pulse-Echo (0072): 155kHz (No Damage Average - 28 Nov Baseline) Delta

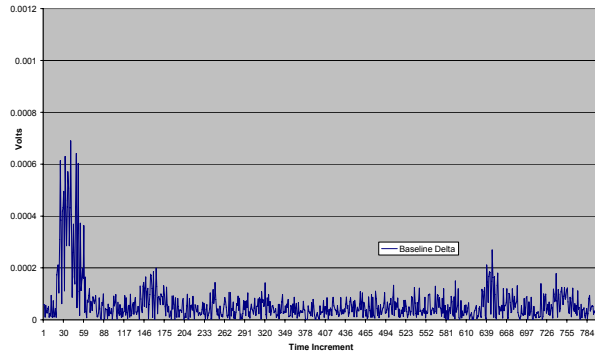

Pulse-Echo (Sensor 0072): 30 Nov 06, Block 10 @ 165mm and 180°, No Damage Baseline

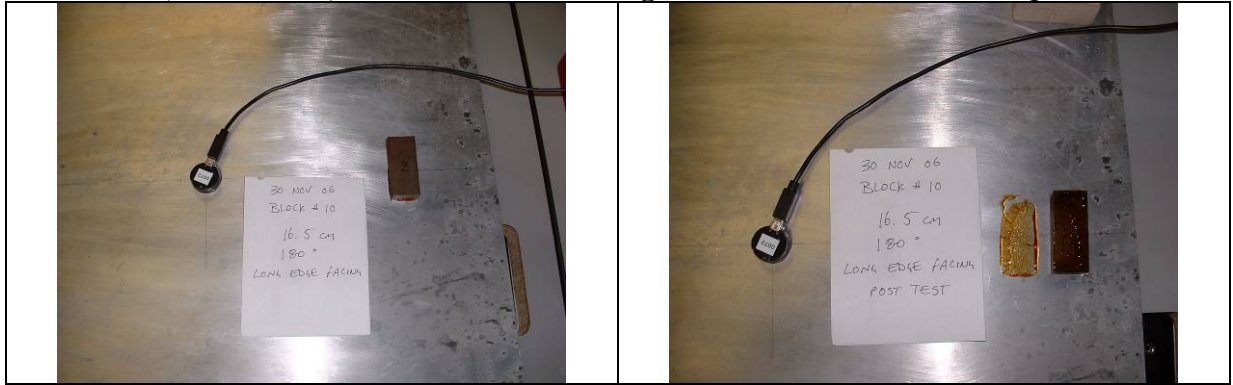

Pulse-Echo: 95kHz Sensor 0072

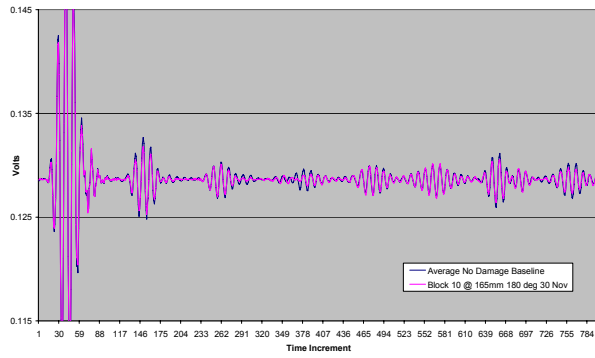

Pulse-Echo (0072): 95kHz (No Damage Average - 30 Nov Block 10) Delta

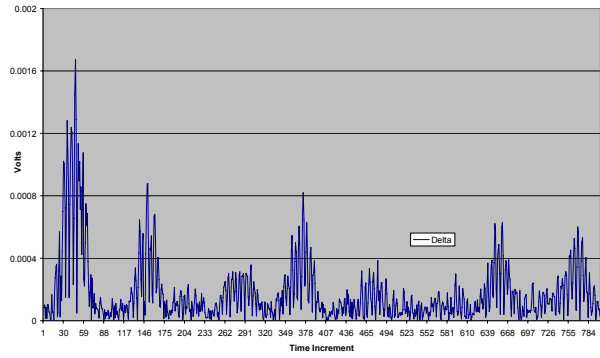

Pulse-Echo (0072): 95kHz (No Damage Average - 30 Nov Baseline) Delta

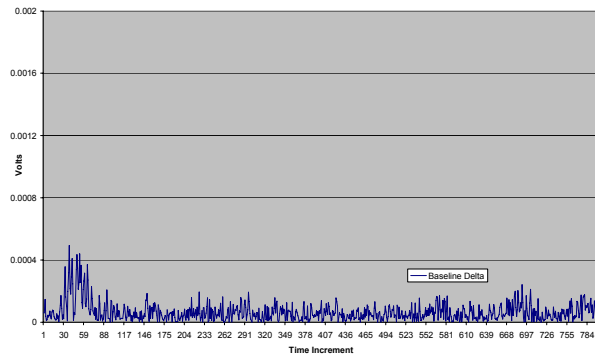

Pulse-Echo: 125kHz Sensor 0072

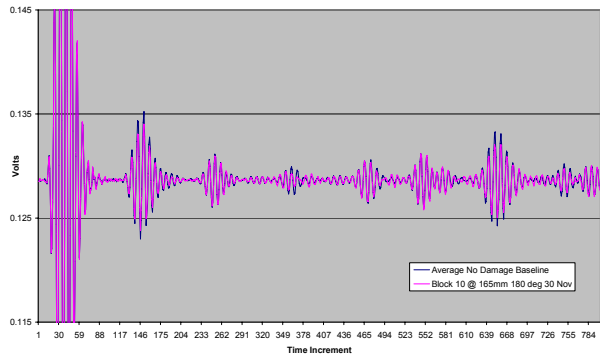

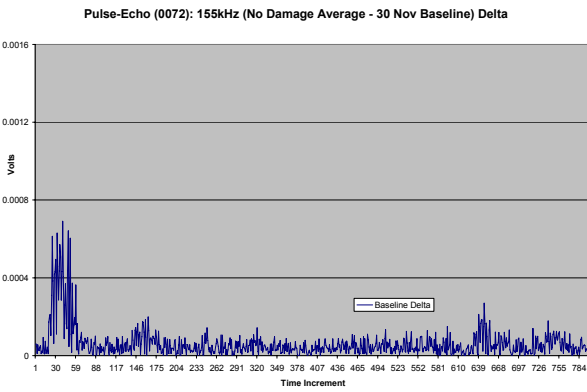
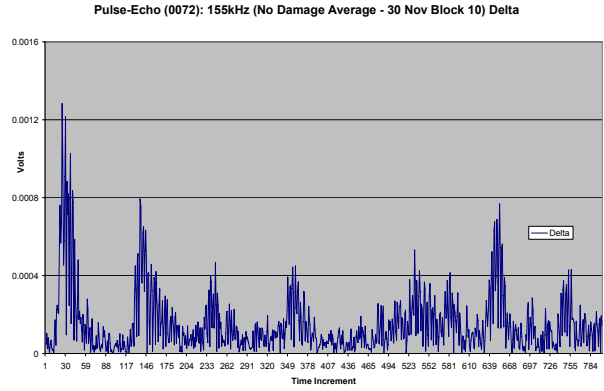
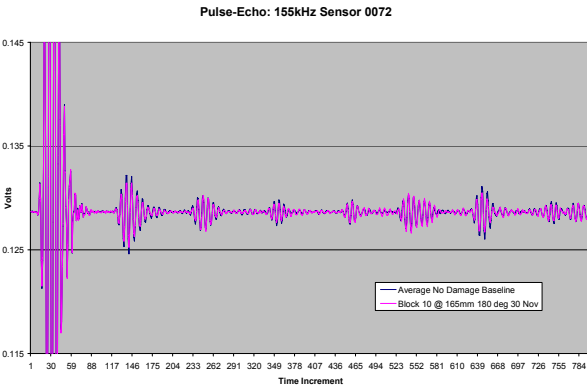
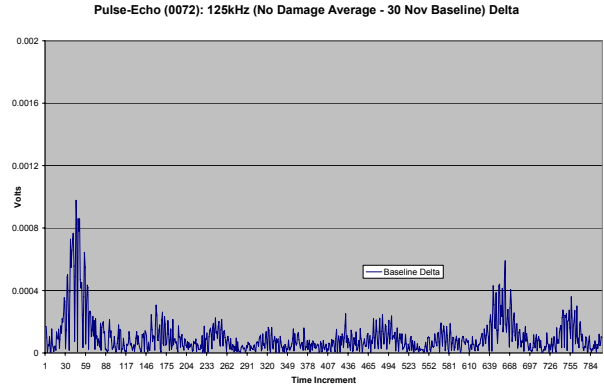
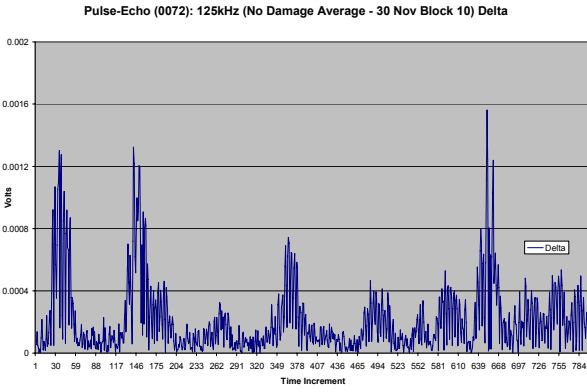

Pulse-Echo (Sensor 0072): 13 Dec 06, 3mm Gouge @ 165mm and 0°, No Damage Baseline

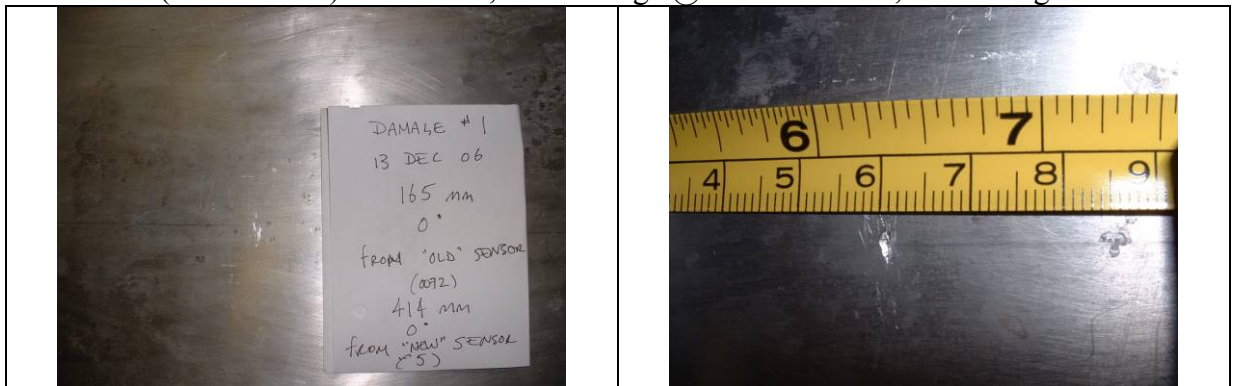

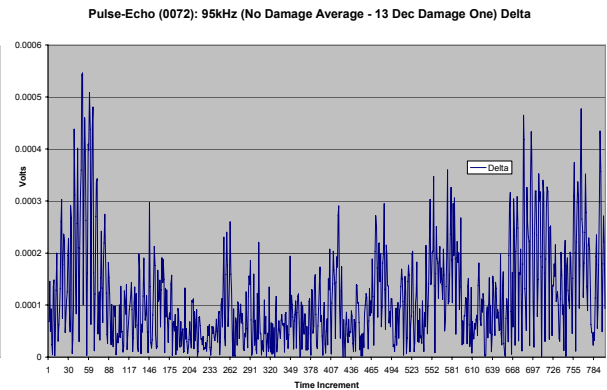
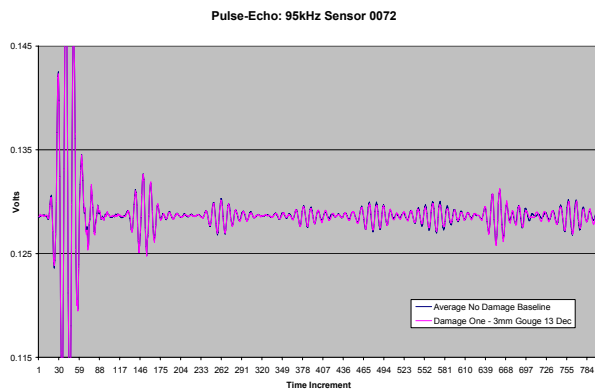
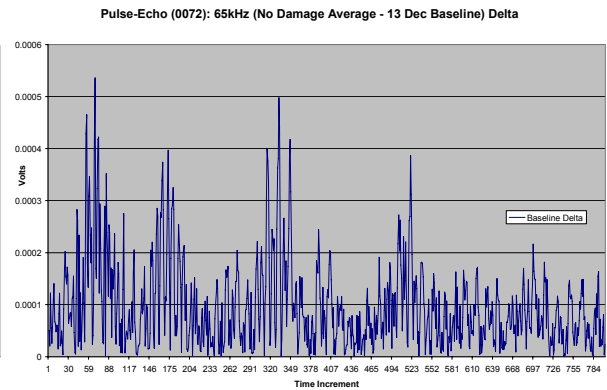
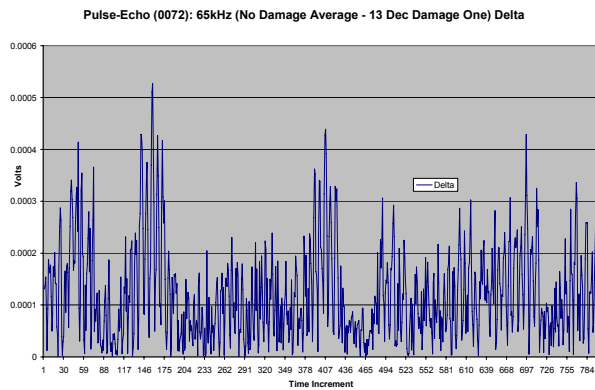
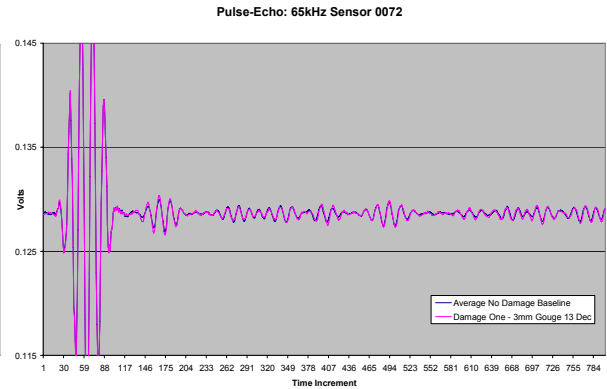
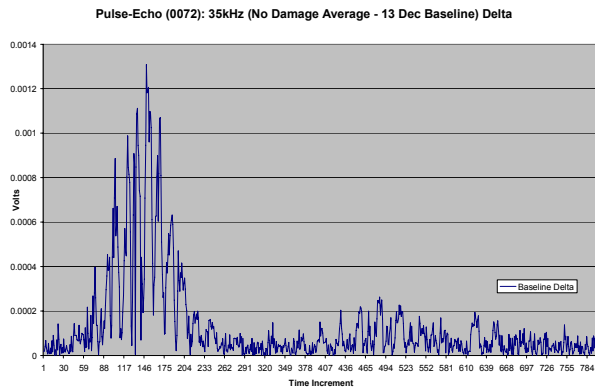
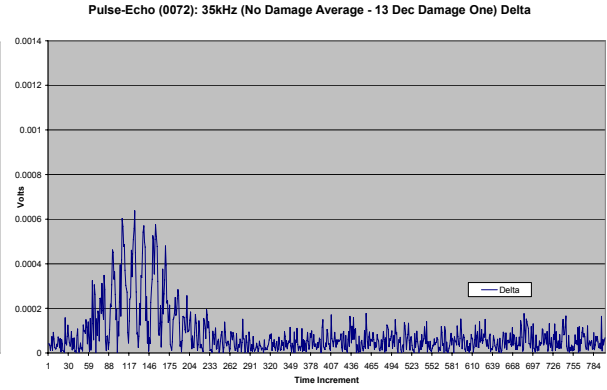
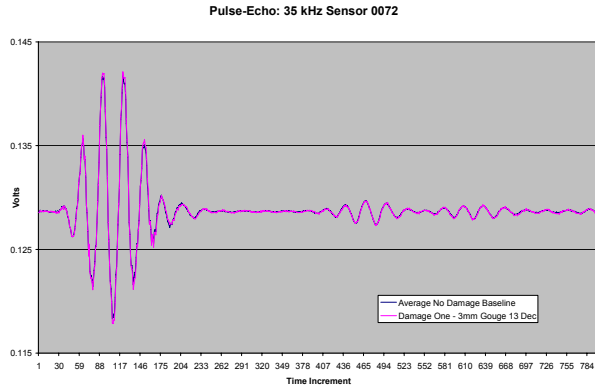

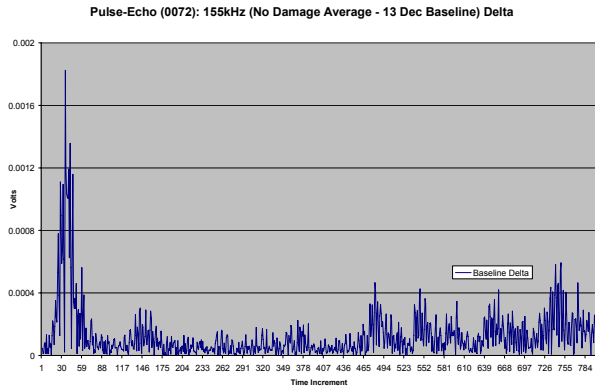
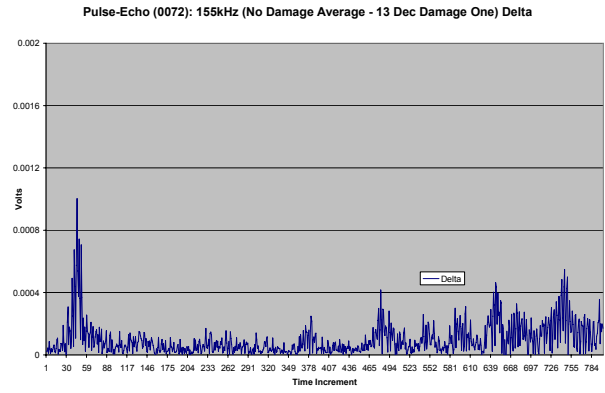
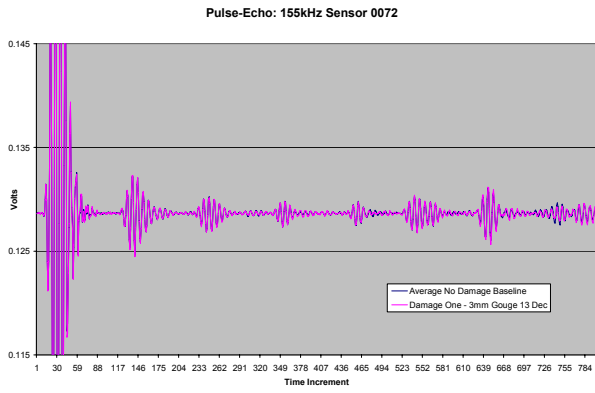
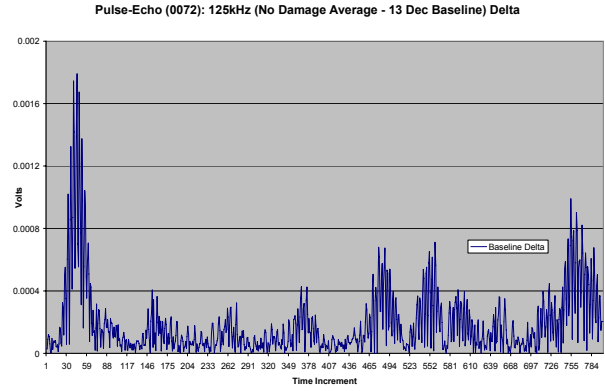
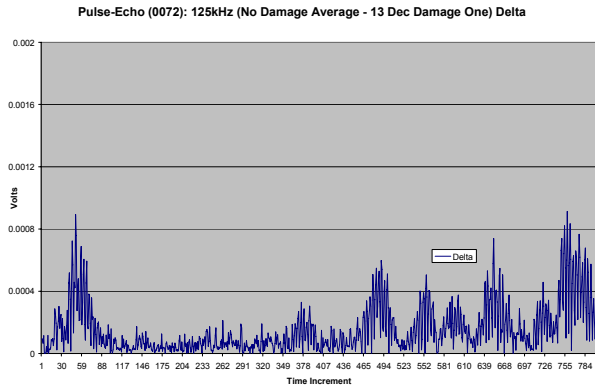
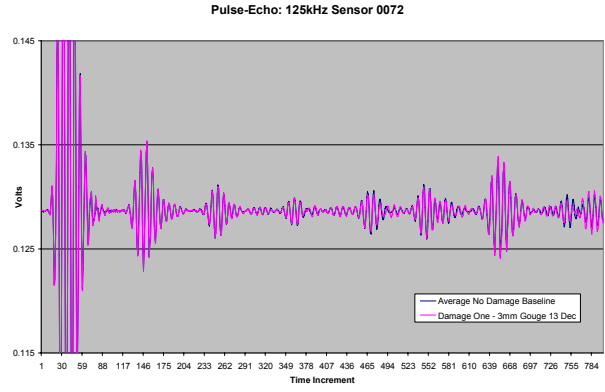
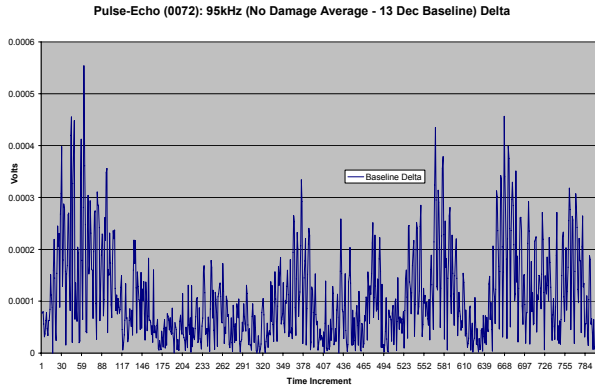

Pulse-Echo (Sensor 0072): 14 Dec 06, 3mm Gouge @ 165mm and 0°, No Damage Baseline

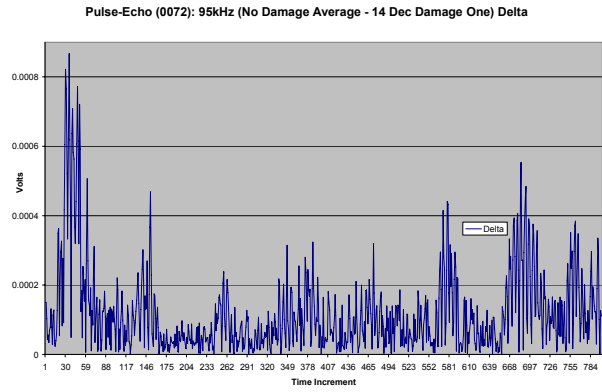
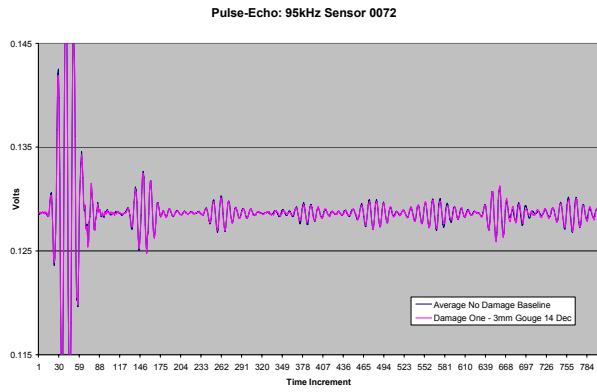
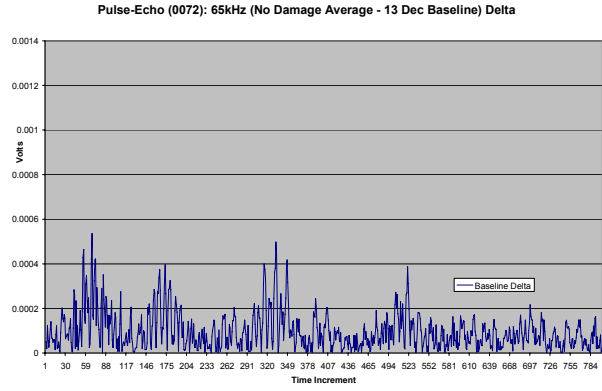
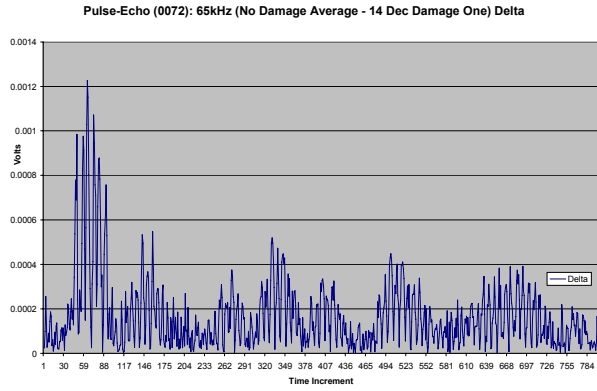
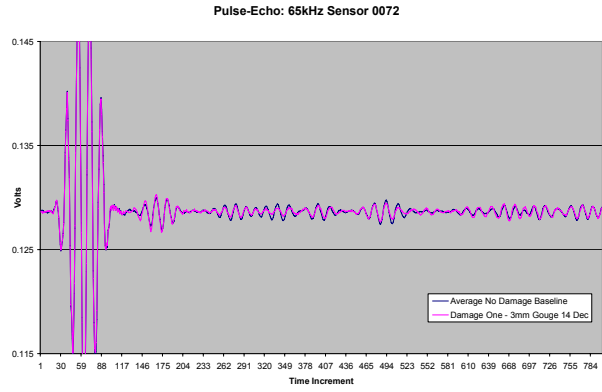
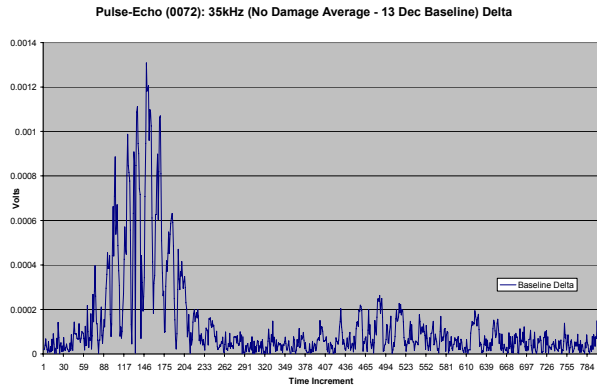
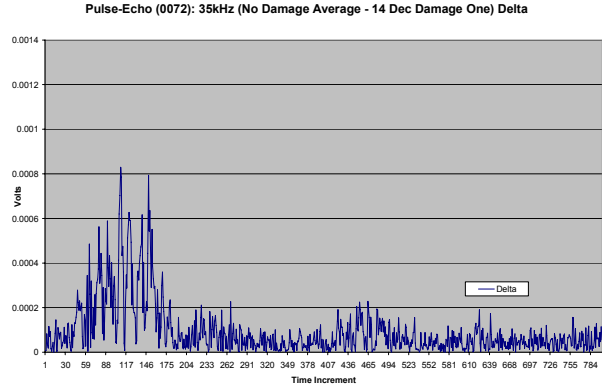
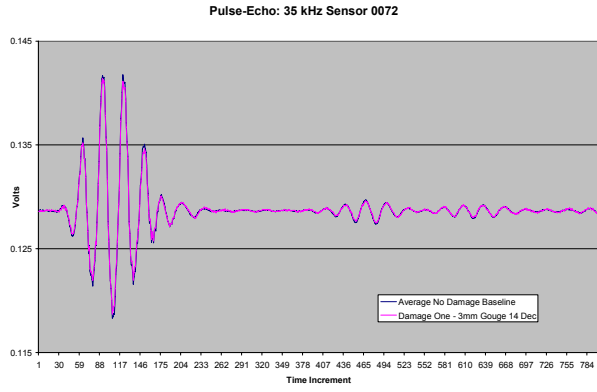

Pulse-Echo (0072): 95kHz (No Damage Average - 13 Dec Baseline) Delta

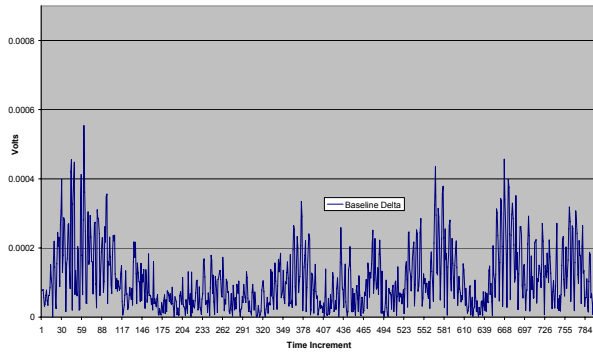

Pulse-Echo: 125kHz Sensor 0072

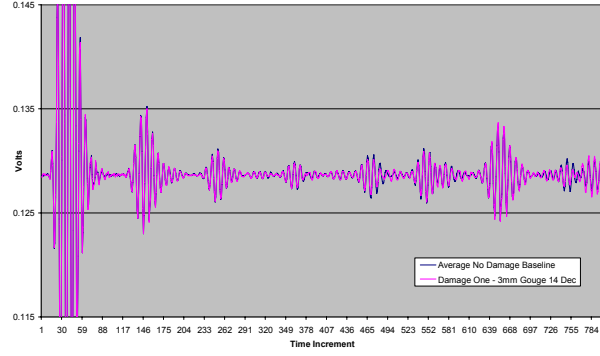

Pulse-Echo (0072): 125kHz (No Damage Average - 14 Dec Damage One) Delta

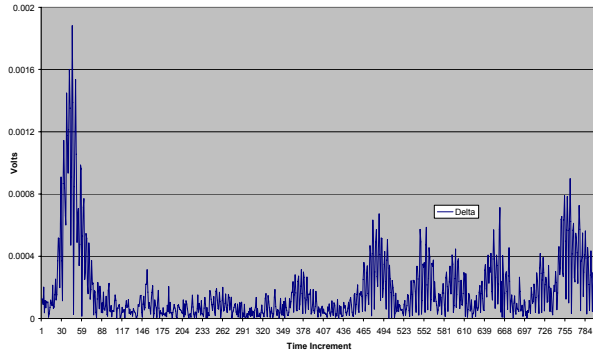

Pulse-Echo (0072): 125kHz (No Damage Average - 13 Dec Baseline) Delta

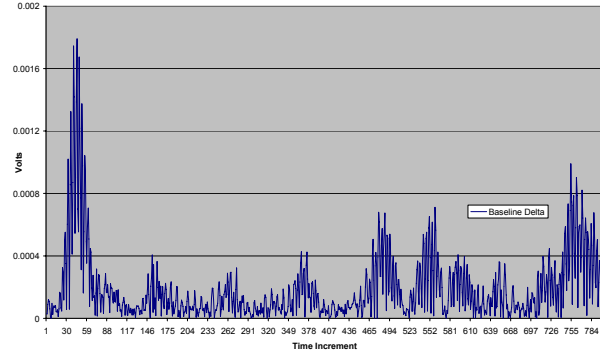

Pulse-Echo: 155kHz Sensor 0072

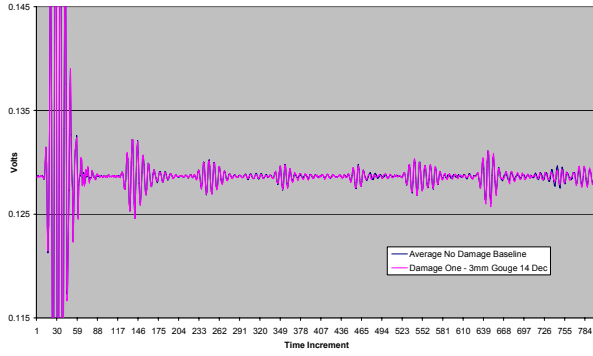

Pulse-Echo (0072): 155kHz (No Damage Average - 14 Dec Damage One) Delta

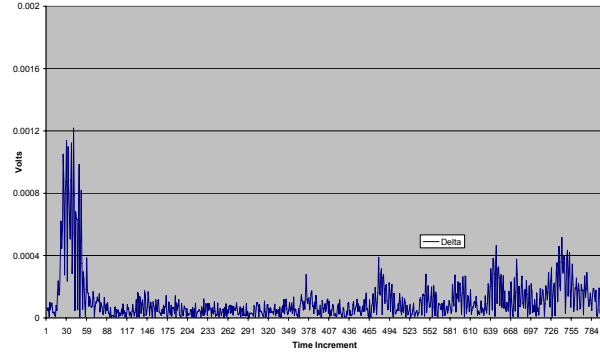

Pulse-Echo (0072): 155kHz (No Damage Average - 13 Dec Baseline) Delta

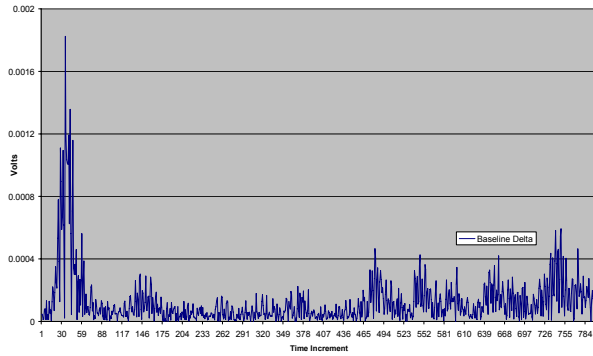

Pulse-Echo (Sensor 0072): 14 Dec 06, 4mm Cross Gouge @ 165mm and 0°
 Damage One Baseline

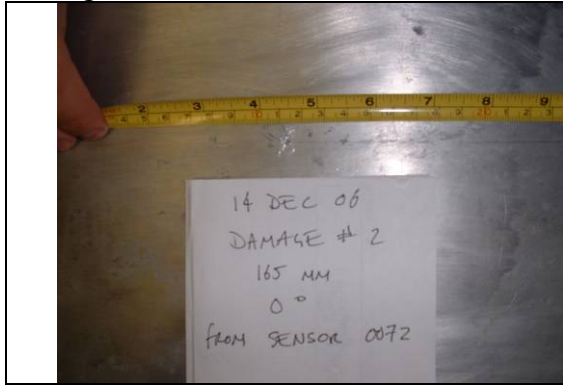

Pulse-Echo: 35 kHz Sensor 0072

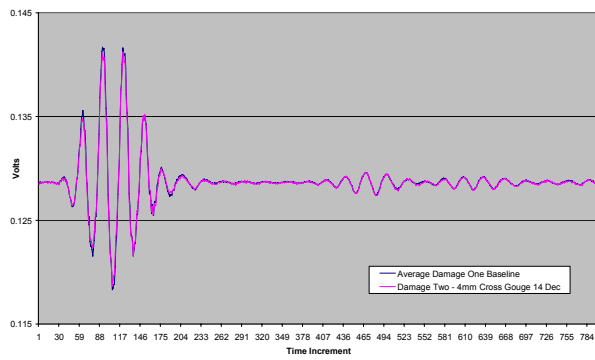

Pulse-Echo (0072): 35kHz (Damage One Average - 14 Dec Damage Two) Delta

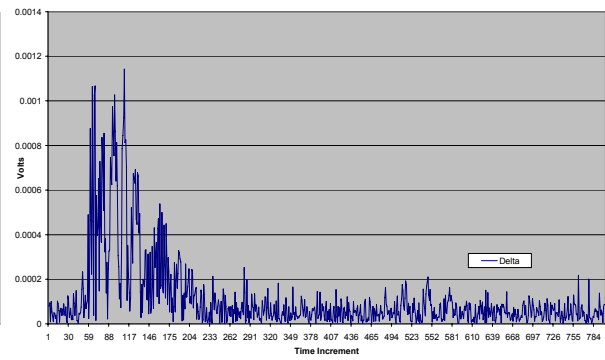

Pulse-Echo (0072): 35kHz (13 Dec Damage One - 14 Dec Damage One) Delta

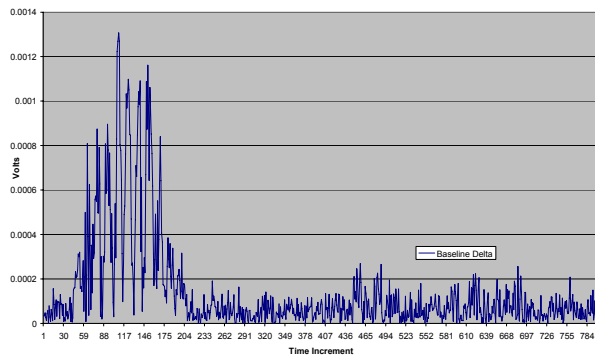

Pulse-Echo: 65kHz Sensor 0072

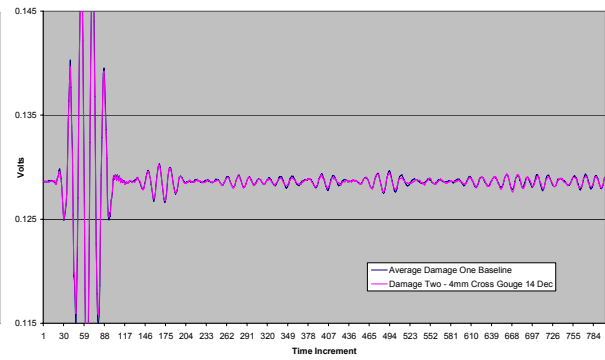

Pulse-Echo (0072): 65kHz (Damage One Average - 14 Dec Damage Two) Delta

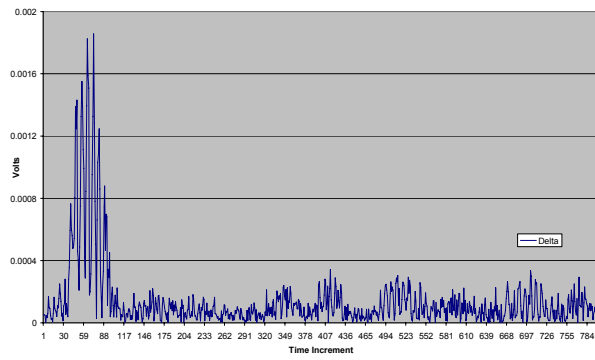

Pulse-Echo (0072): 65kHz (13 Dec Damage One - 14 Dec Damage One) Delta

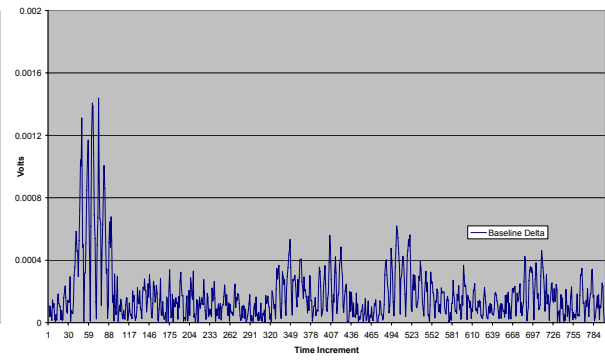

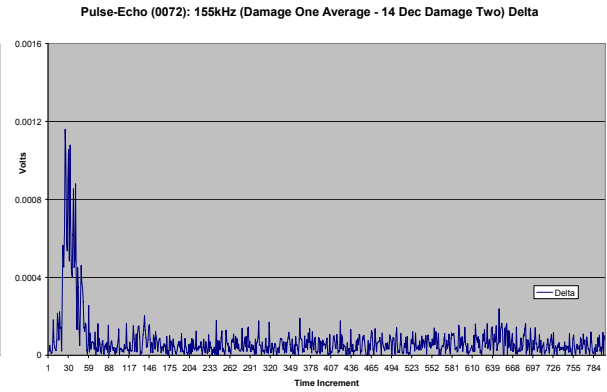
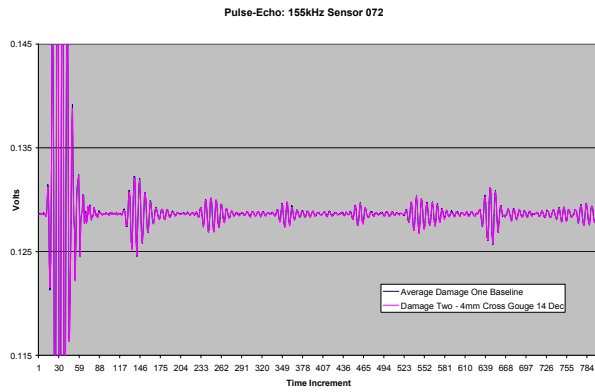
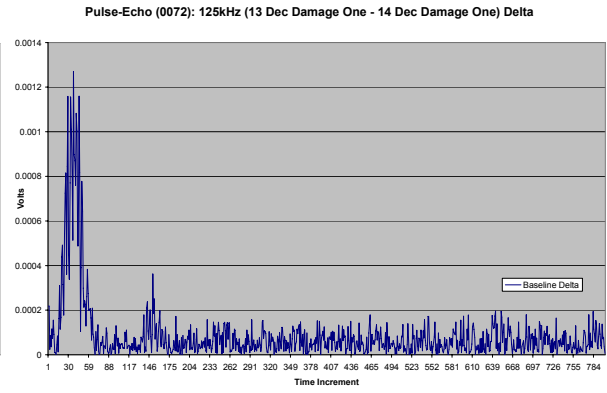
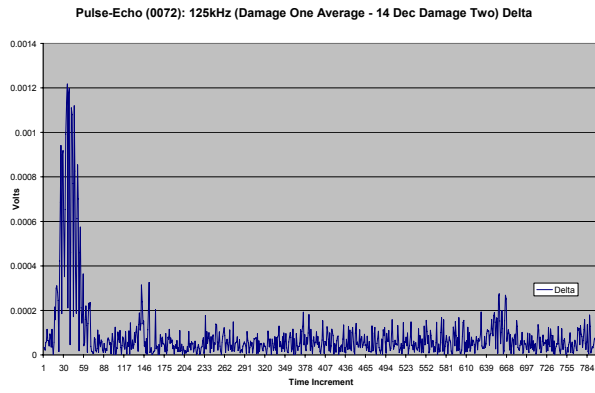
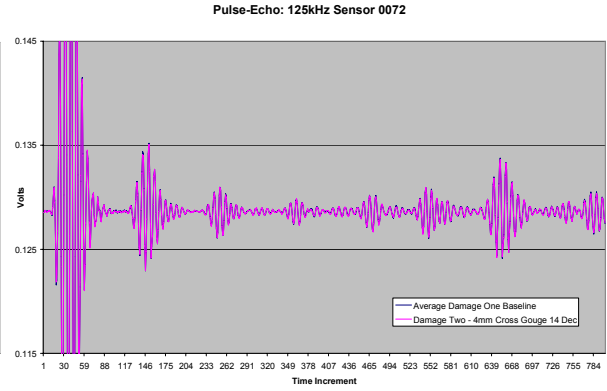
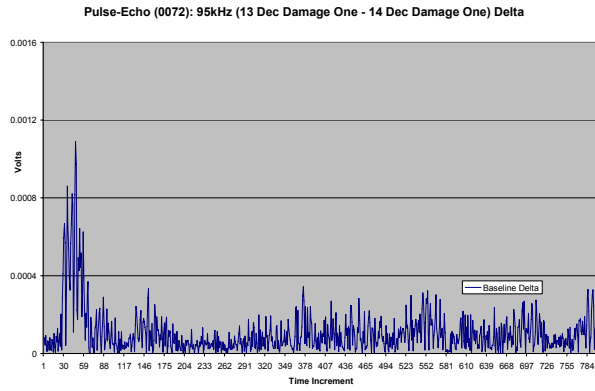
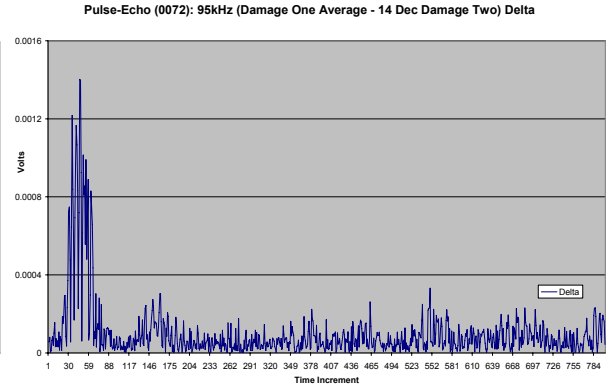
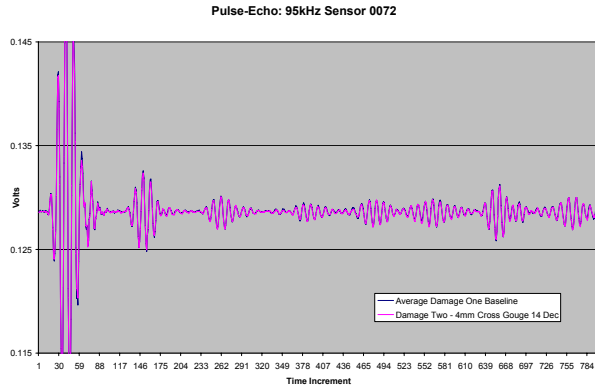

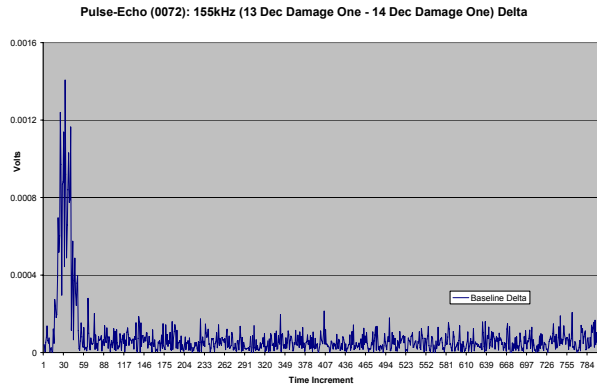

**Pulse-Echo (Sensor 0072): 15 Dec 06, 4mm Cross Gouge @ 165mm and 0°
Damage One Baseline**

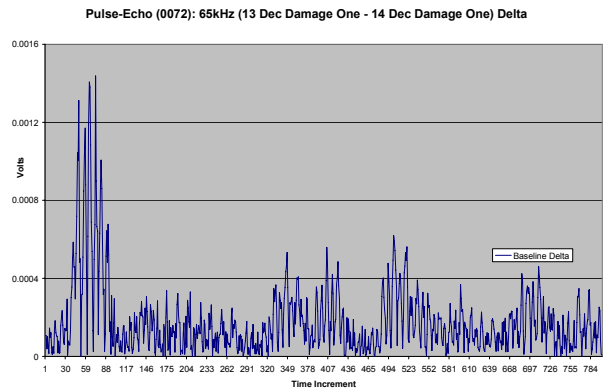
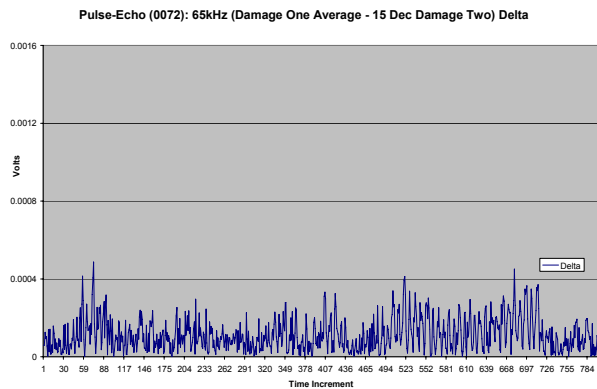
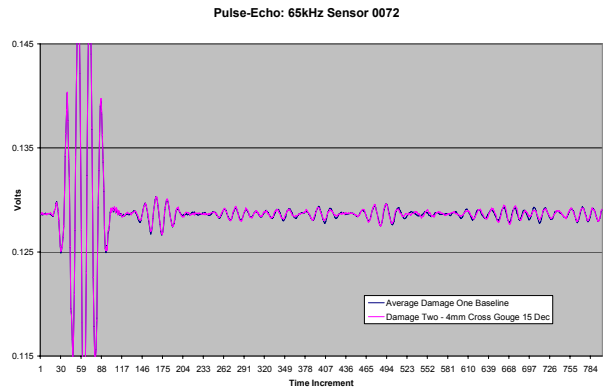
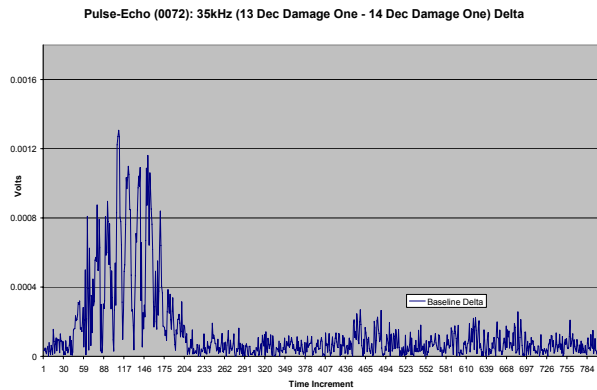
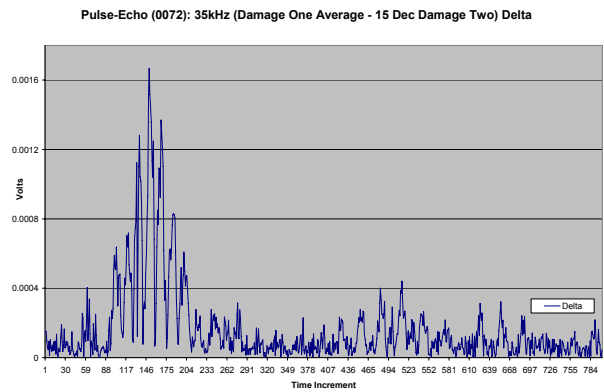
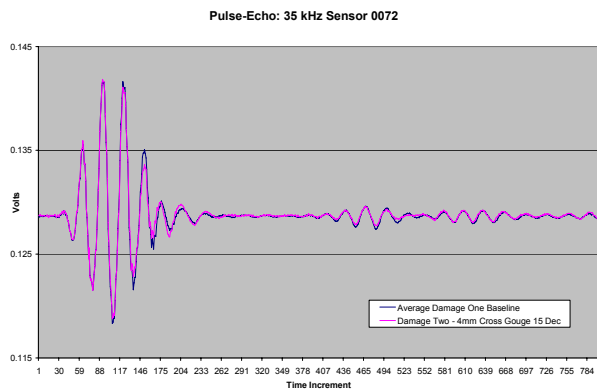

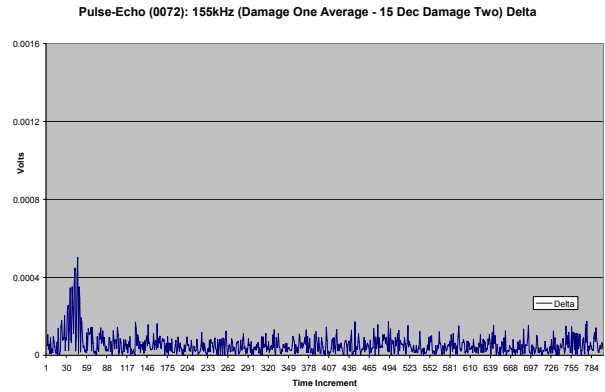
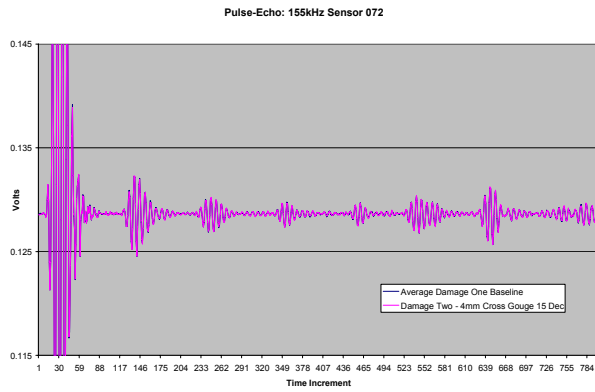
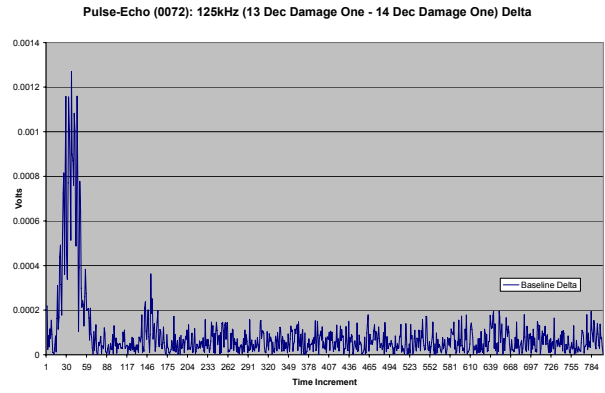
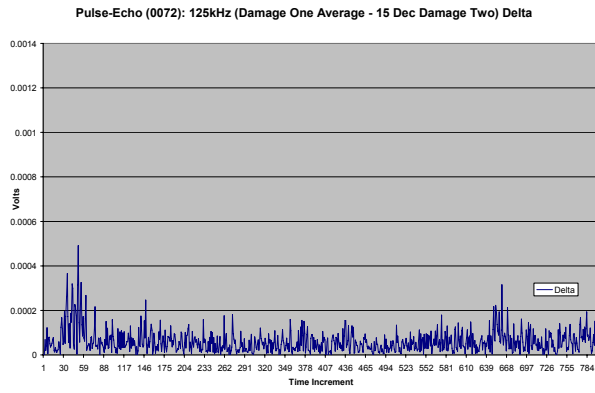
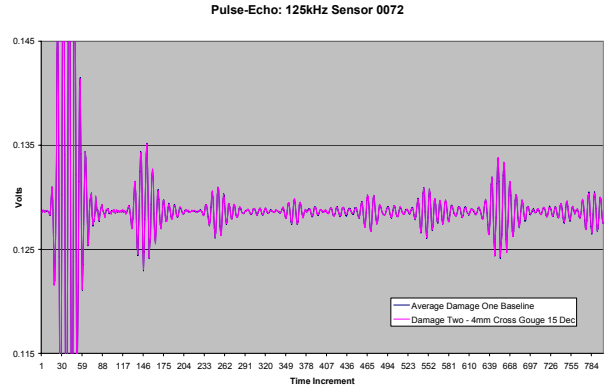
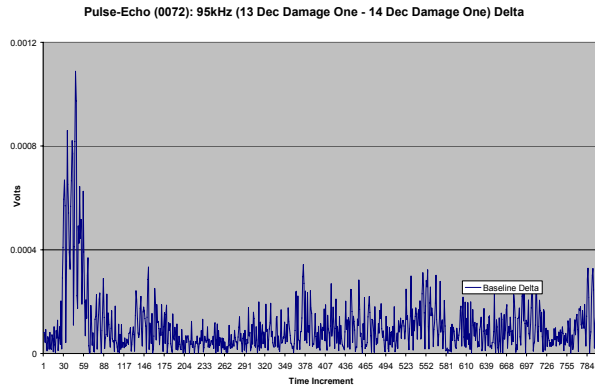
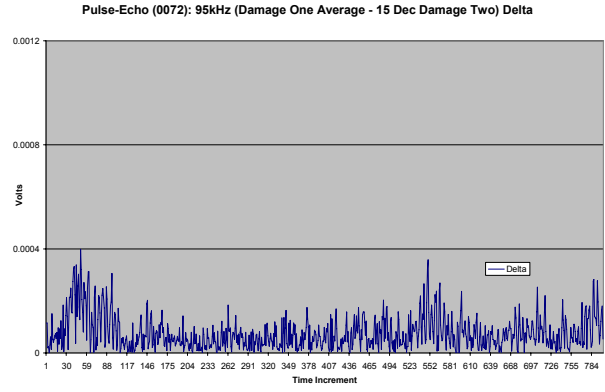
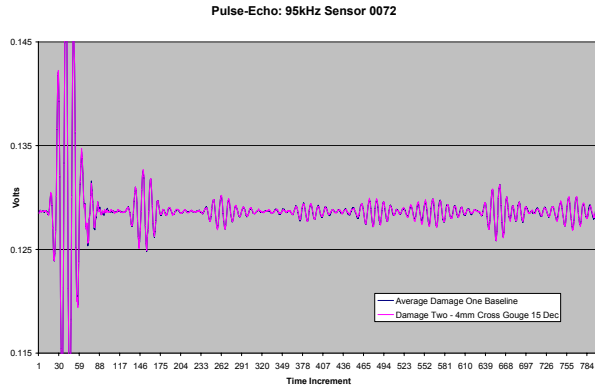

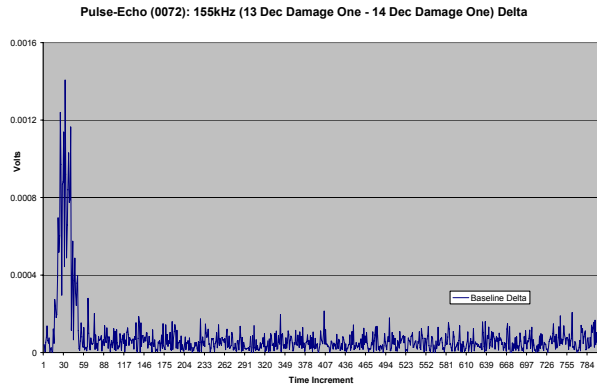

Pulse-Echo (Sensor 0072): 15 Dec 06, 5mm Partial Hole @ 165mm and 0°
Damage Two Baseline

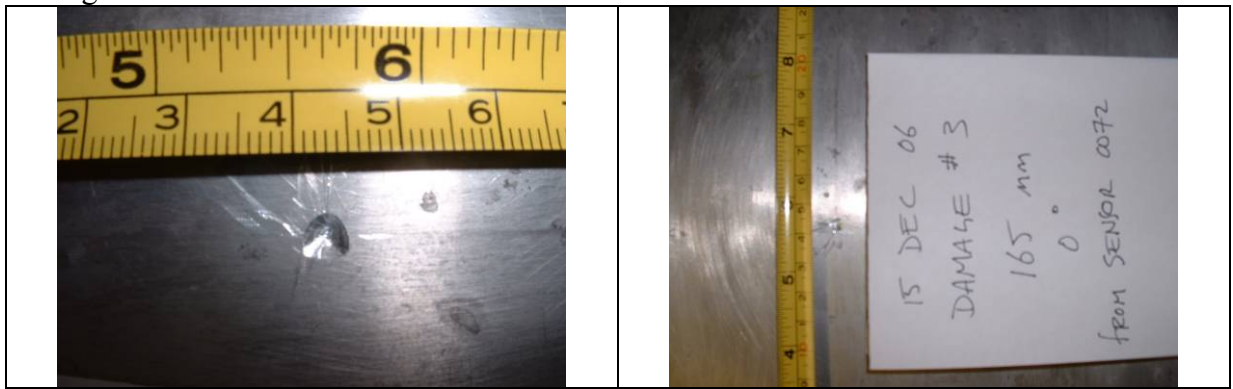

Pulse-Echo: 35 kHz Sensor 0072

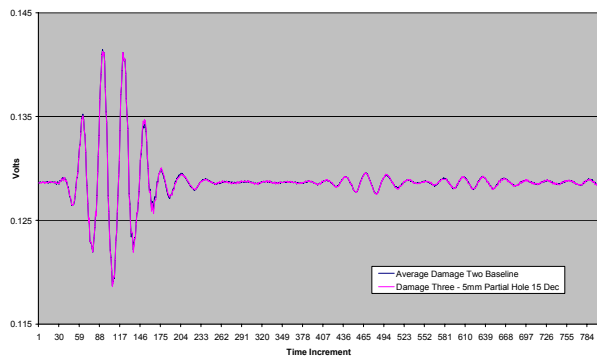

Pulse-Echo (0072): 35kHz (Damage Two Average - 15 Dec Damage Three) Delta

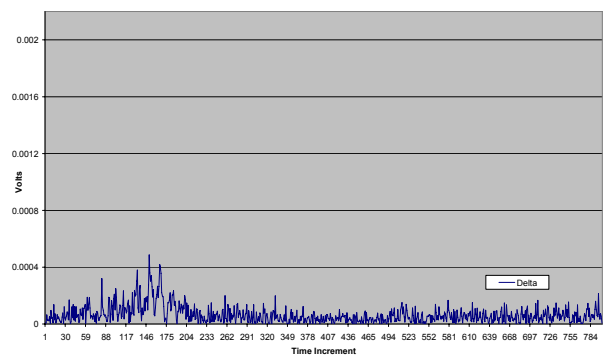

Pulse-Echo (0072): 35kHz (14 Dec Damage Two - 15 Dec Damage Two) Delta

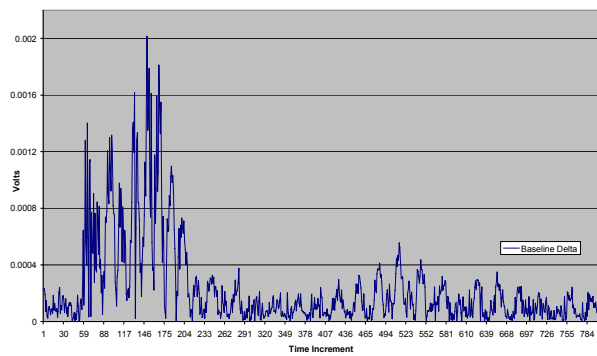

Pulse-Echo: 65kHz Sensor 0072

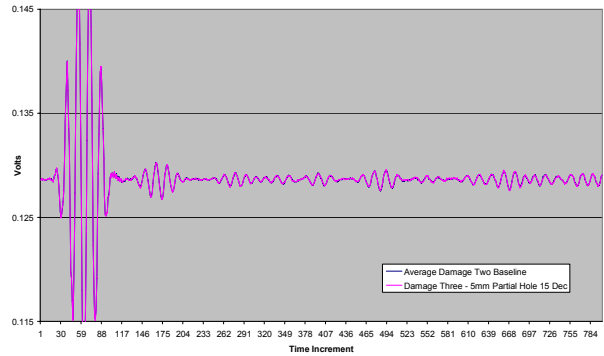

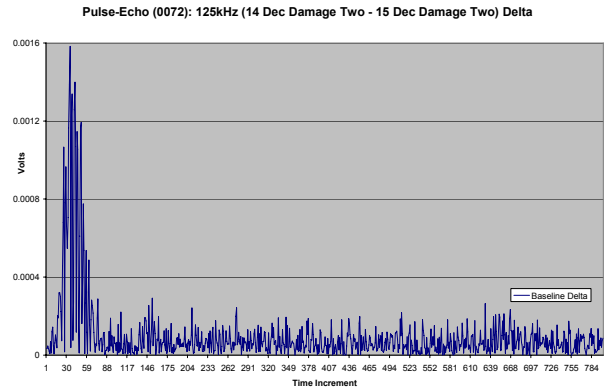
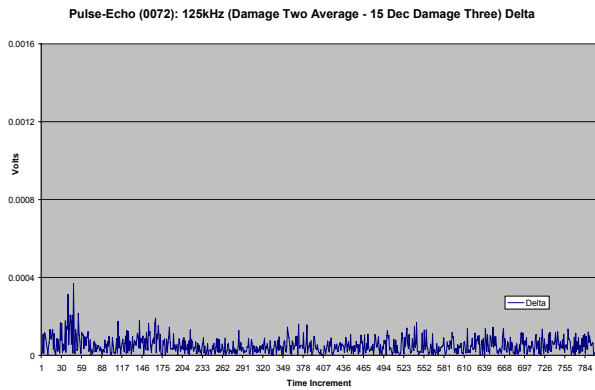
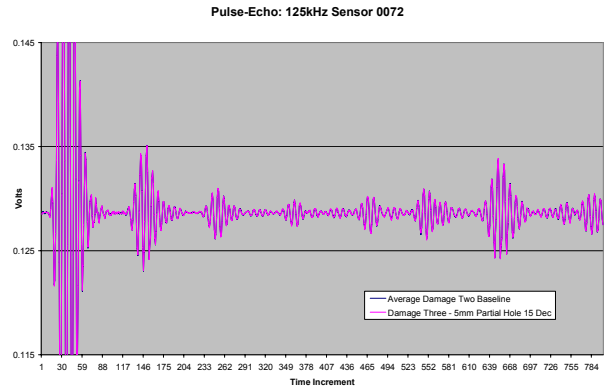
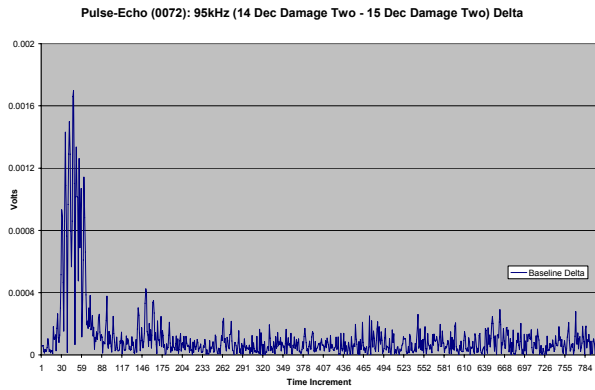
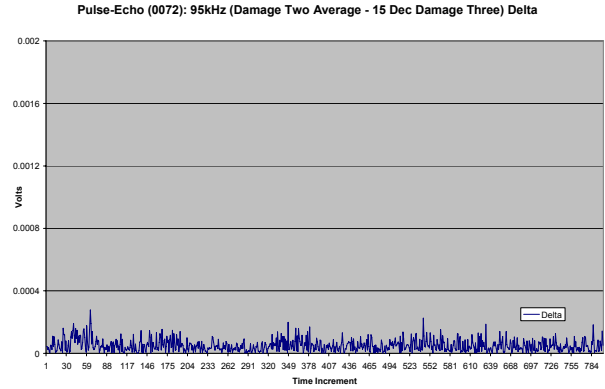
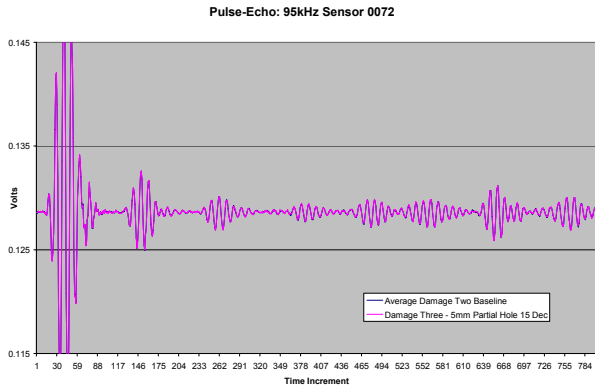
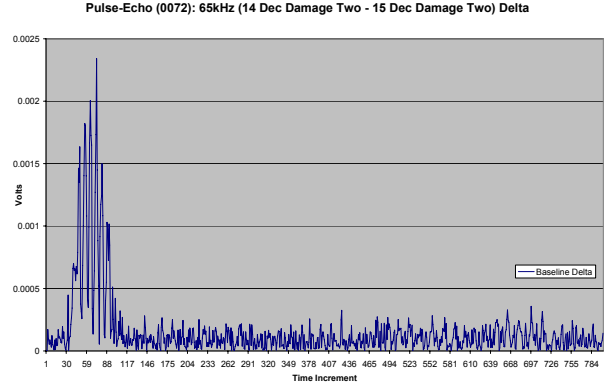
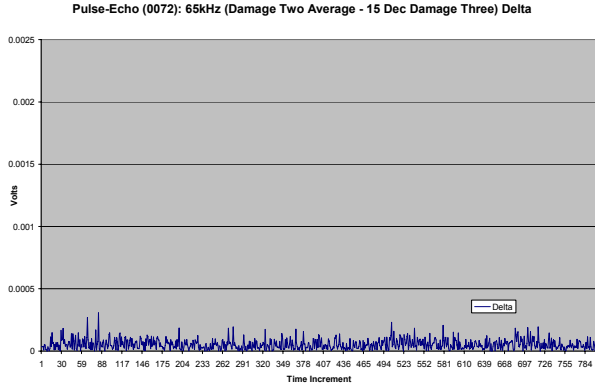

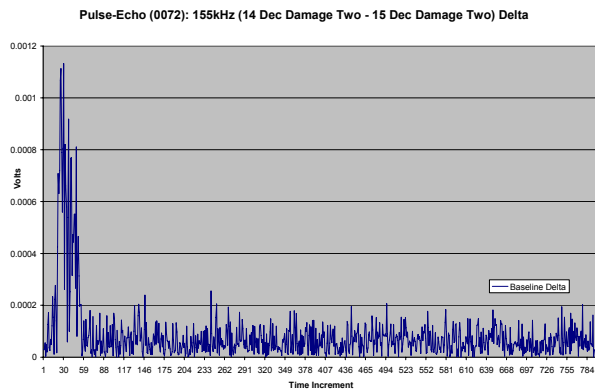
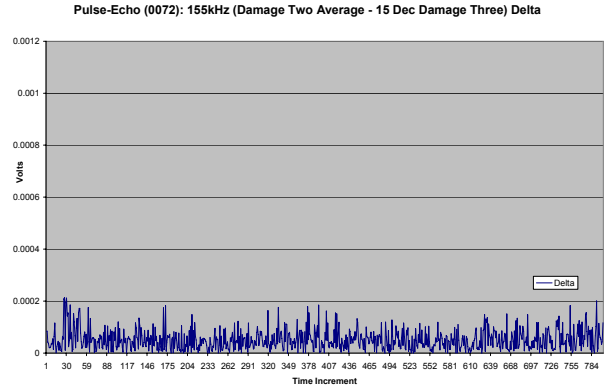
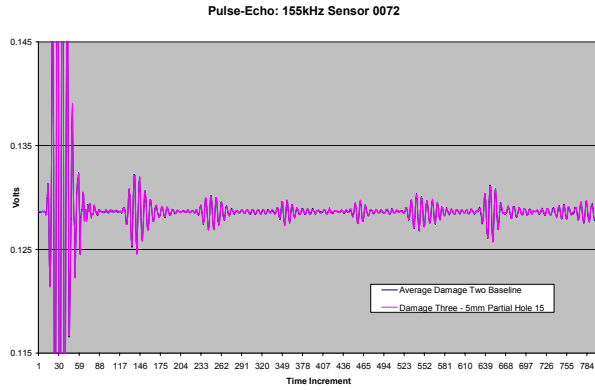

Pulse-Echo (Sensor 0072): 15 Dec 06, 6mm Hole @ 165mm and 0°, Damage Two Baseline

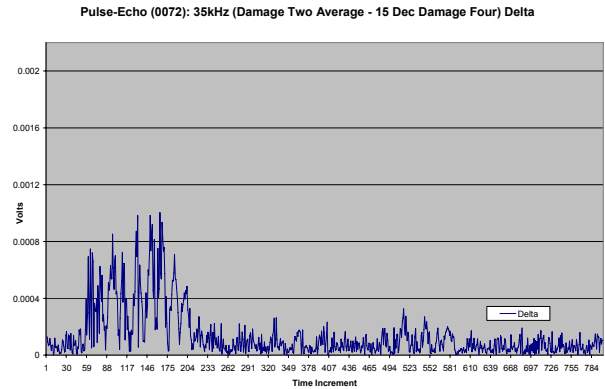
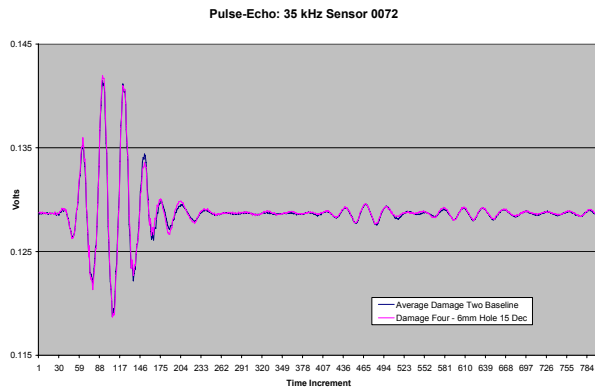
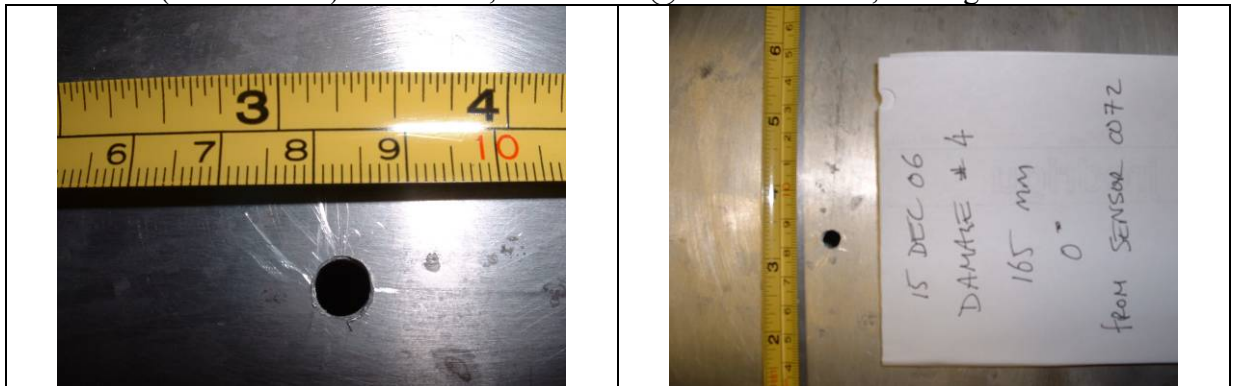

Pulse-Echo (0072): 35kHz (14 Dec Damage Two - 15 Dec Damage Two) Delta

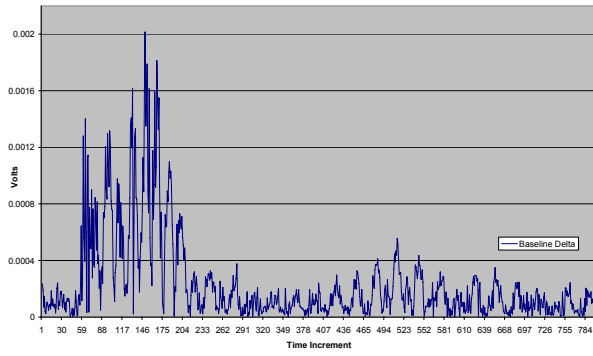

Pulse-Echo: 65kHz Sensor 0072

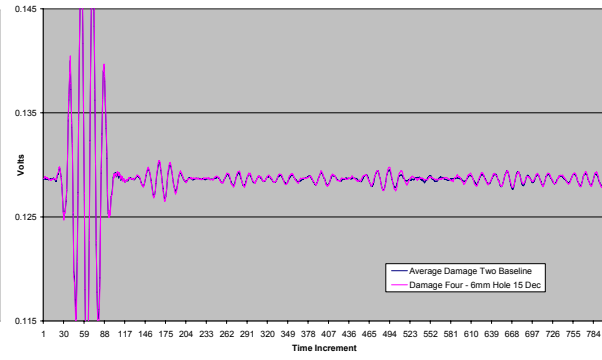

Pulse-Echo (0072): 65kHz (Damage Two Average - 15 Dec Damage Four) Delta

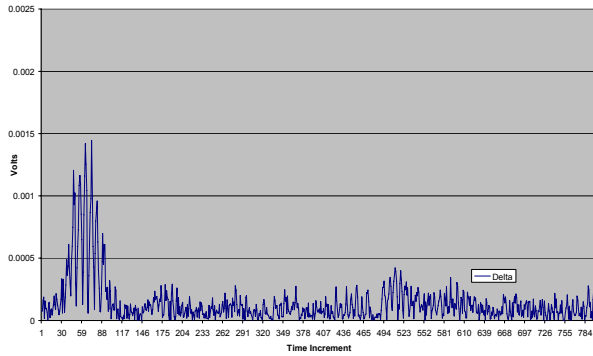

Pulse-Echo (0072): 65kHz (14 Dec Damage Two - 15 Dec Damage Two) Delta

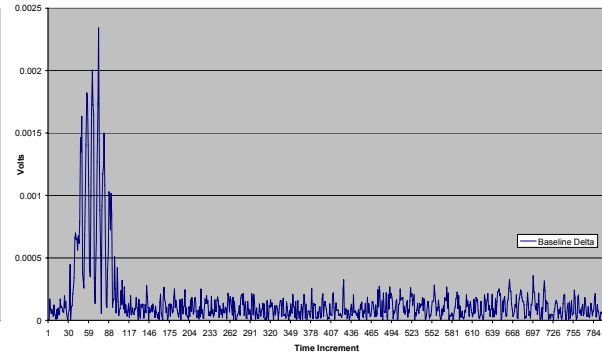

Pulse-Echo: 95kHz Sensor 0072

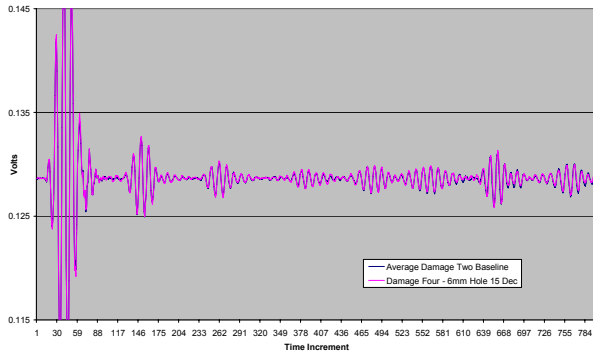

Pulse-Echo (0072): 95kHz (Damage Two Average - 15 Dec Damage Four) Delta

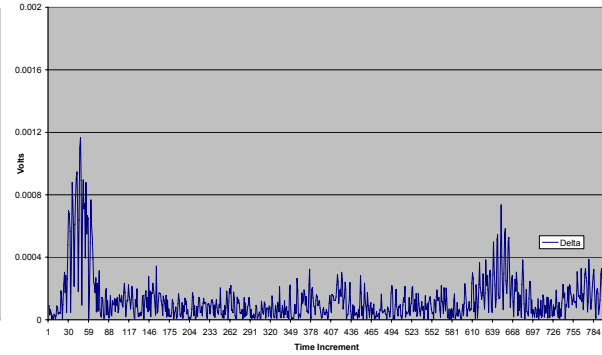

Pulse-Echo (0072): 95kHz (14 Dec Damage Two - 15 Dec Damage Two) Delta

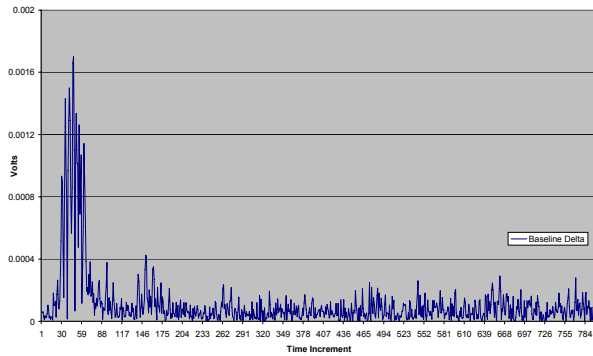

Pulse-Echo: 125kHz Sensor 0072

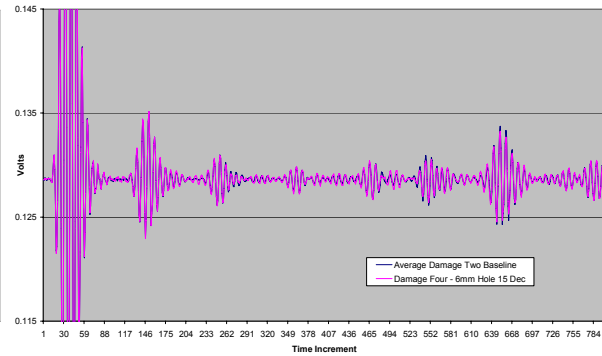

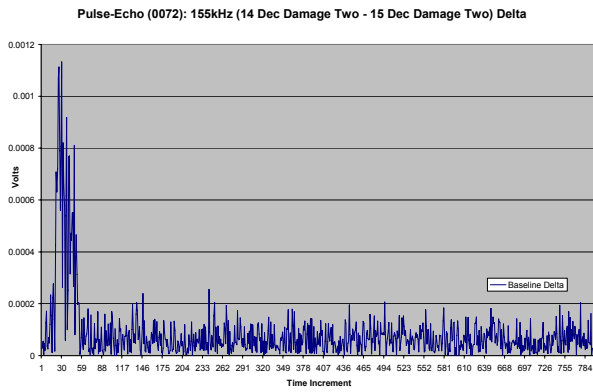
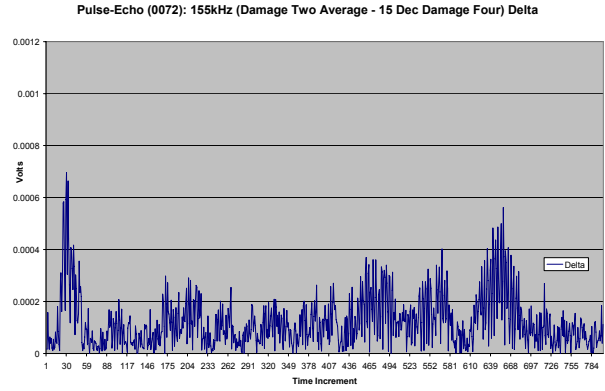
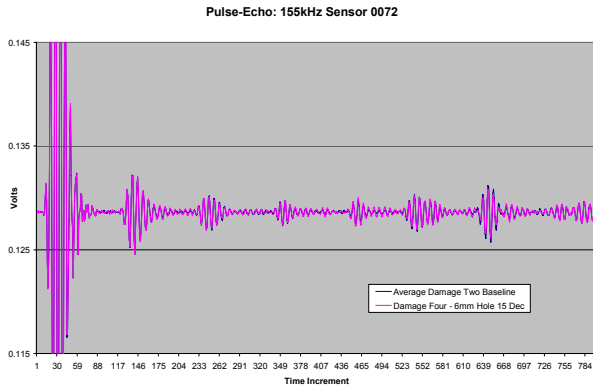
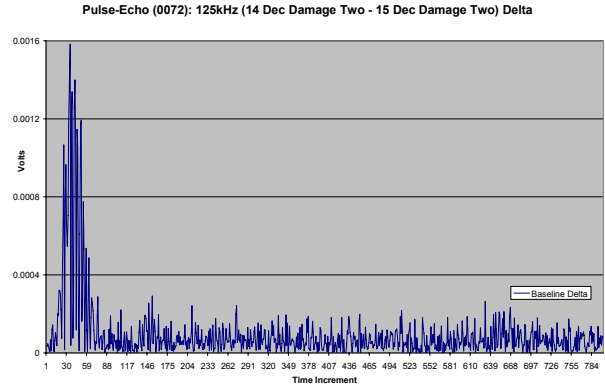
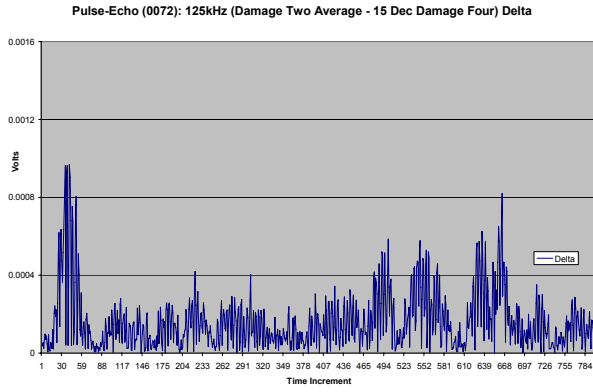

Appendix C. Second Generation Sensor Test Plots

Pitch-Catch (Sensor 5 to 4): 08 Jan 07, Block 10 Centered, No Damage Baseline



Pitch-Catch (5 to 4): 35 kHz Far Sensor (4)

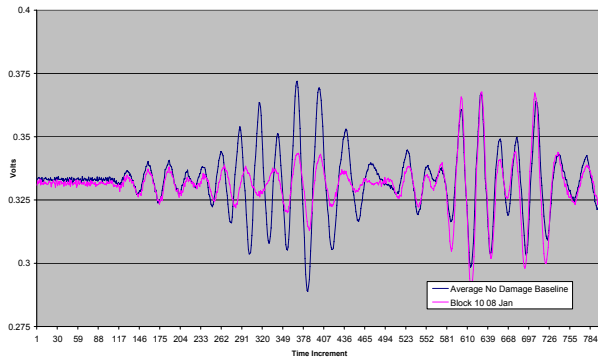

Pitch-Catch (5 to 4): 35kHz (No Damage Average - 08 Jan Block 10) Delta

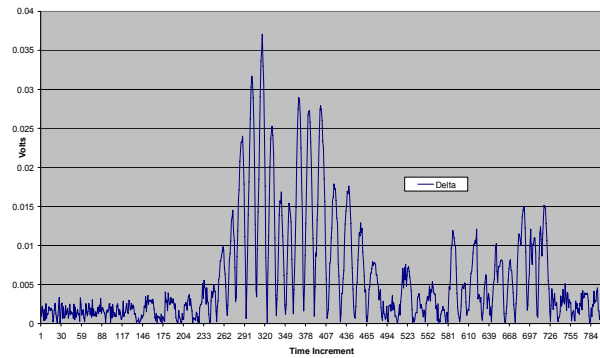

Pitch-Catch (5 to 4): 35kHz (No Damage 17 Jan / 27 Jan) Delta

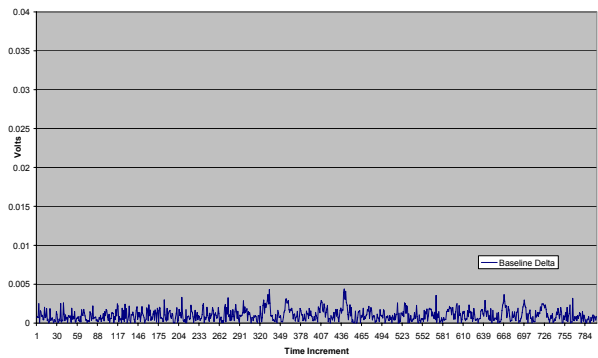

Pitch-Catch (5 to 4): 65kHz Far Sensor (4)

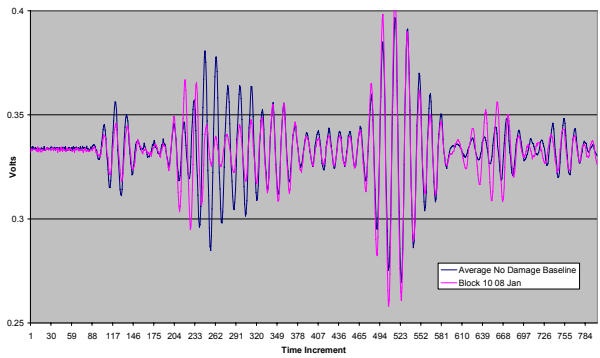

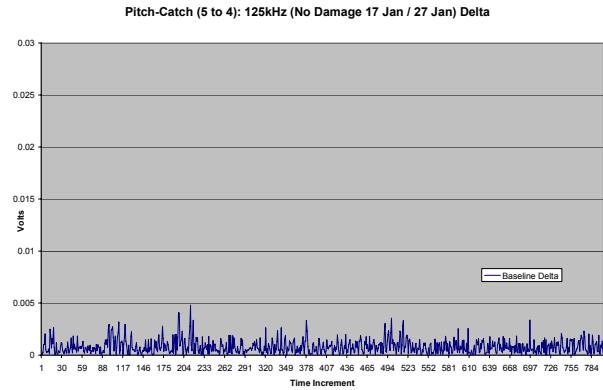
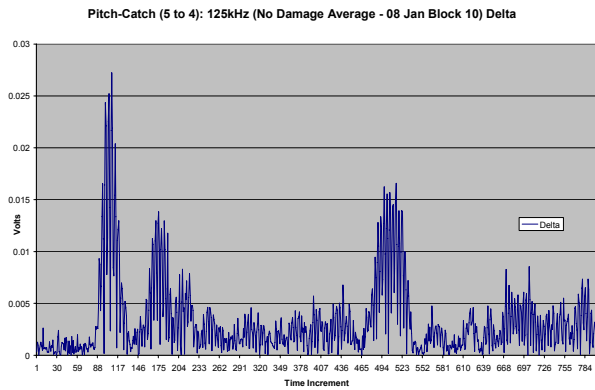
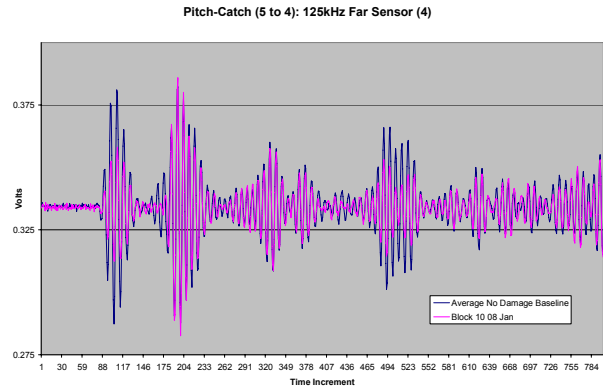
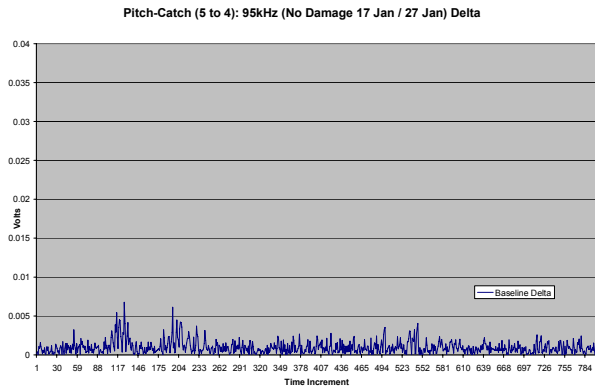
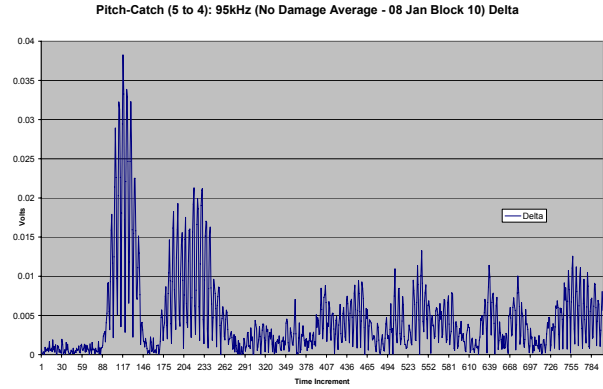
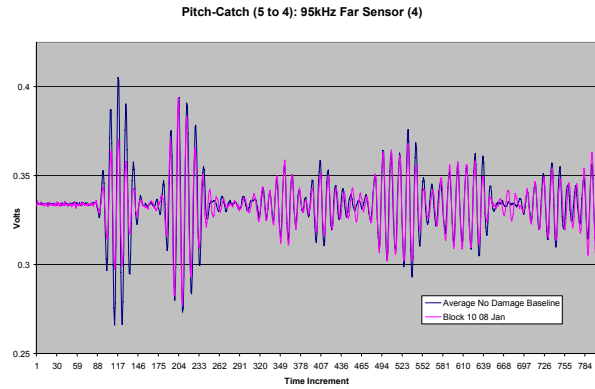
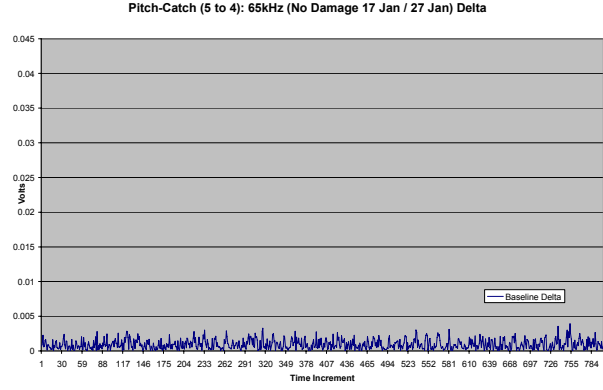
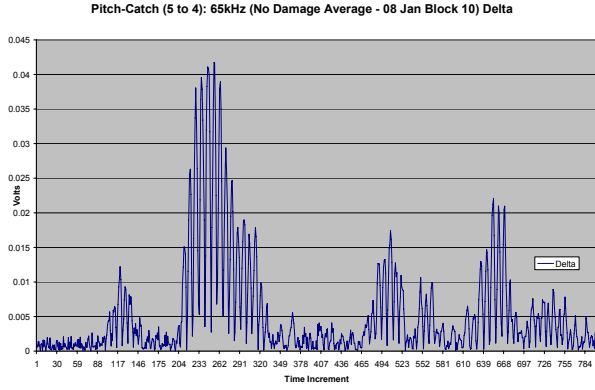

Pitch-Catch (5 to 4): 155kHz Far Sensor (4)

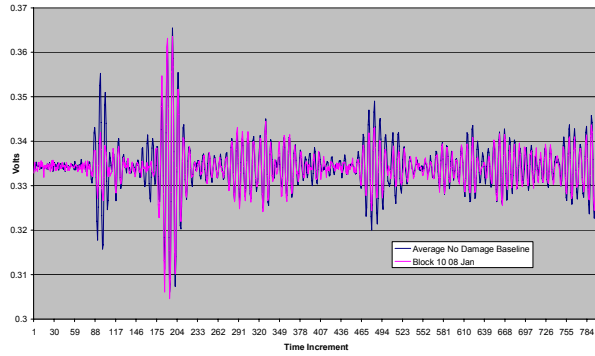

Pitch-Catch (5 to 4): 155kHz (No Damage Average - 08 Jan Block 10) Delta

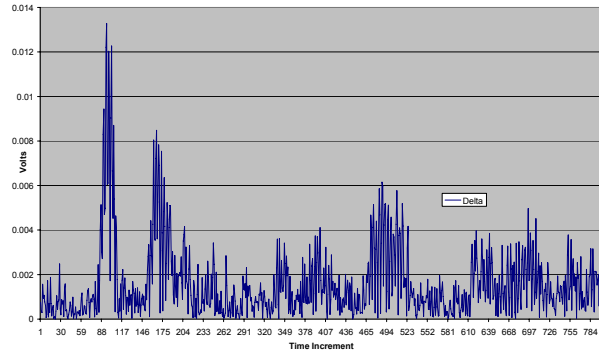

Pitch-Catch (5 to 4): 155kHz (No Damage 17 Jan / 27 Jan) Delta

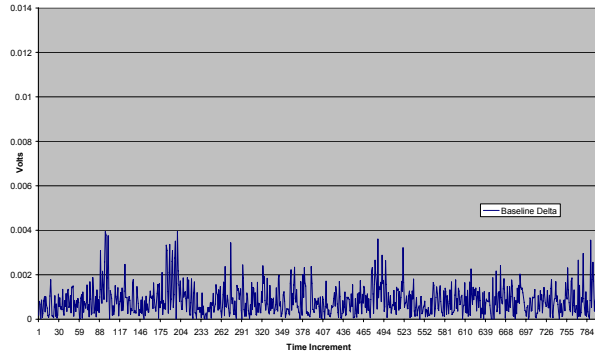

Pitch-Catch (Sensor 5 to 4): 10 Jan 07, Block 7 Centered, Small Face, No Damage Baseline

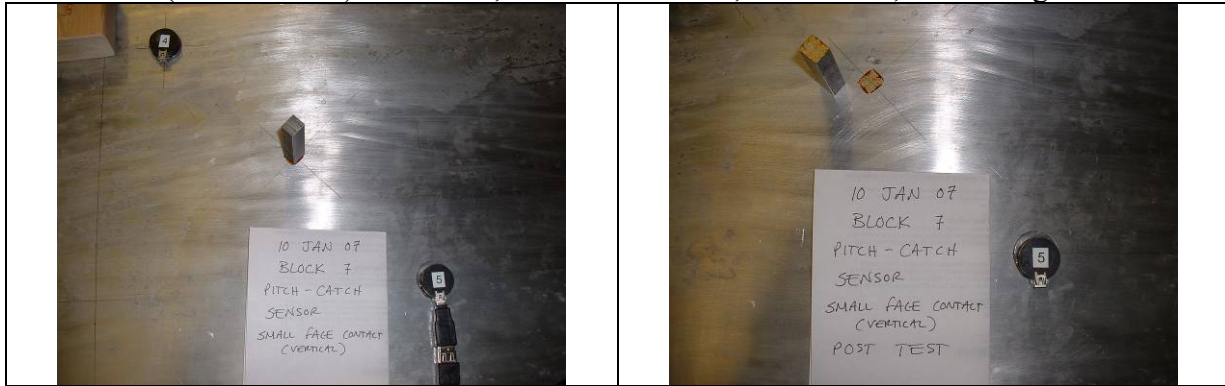

Pitch-Catch (5 to 4): 35 kHz Far Sensor (4)

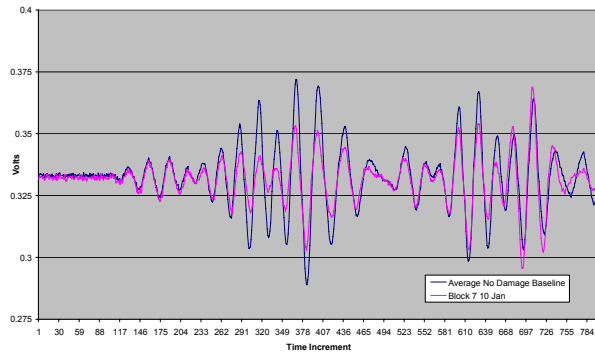

Pitch-Catch (5 to 4): 35kHz (No Damage Average - 10 Jan Block 7) Delta

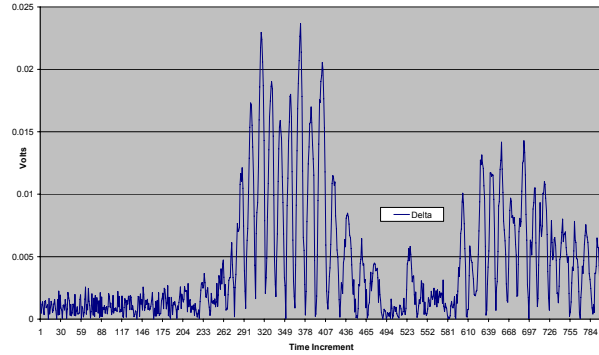

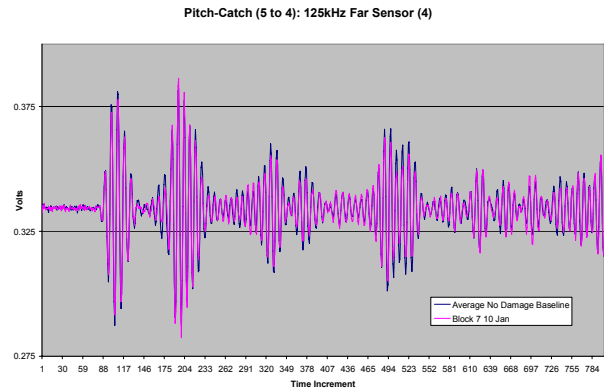
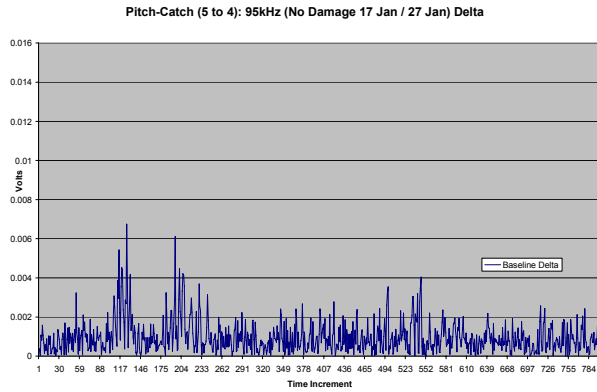
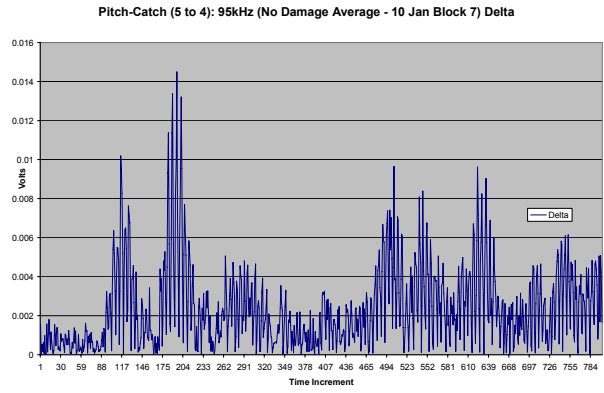
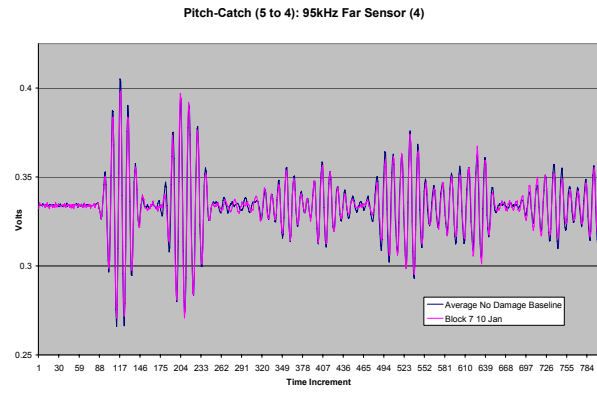
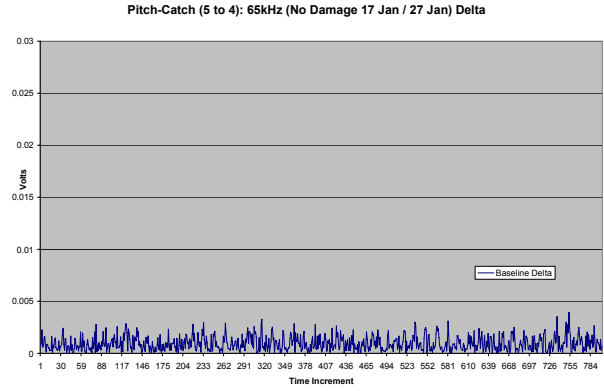
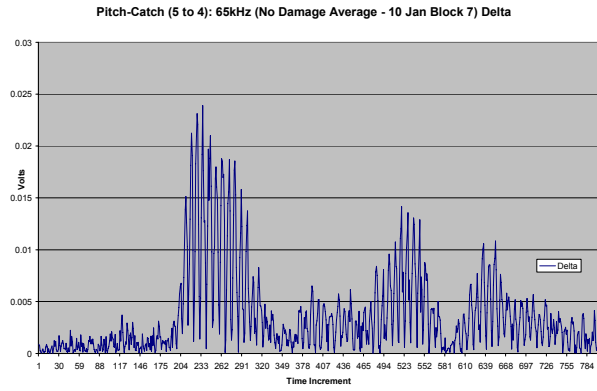
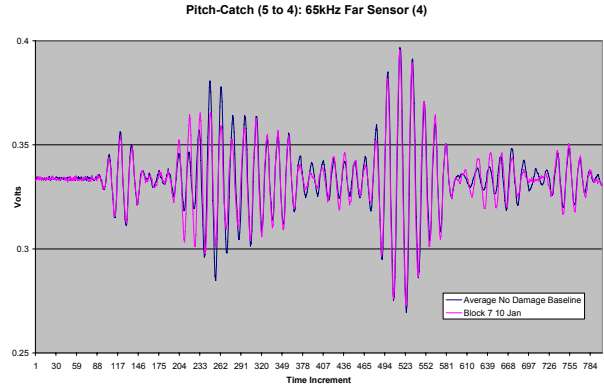
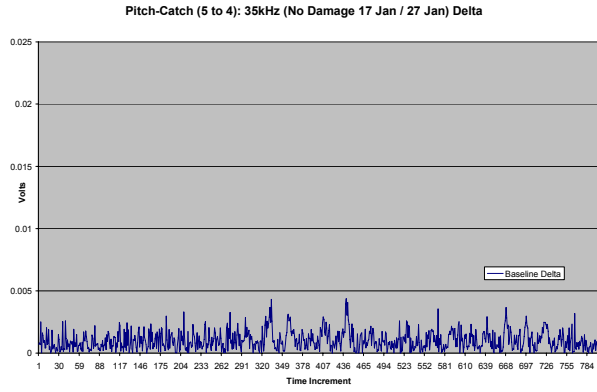

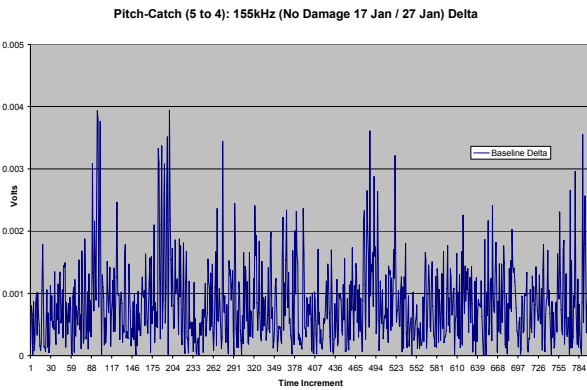
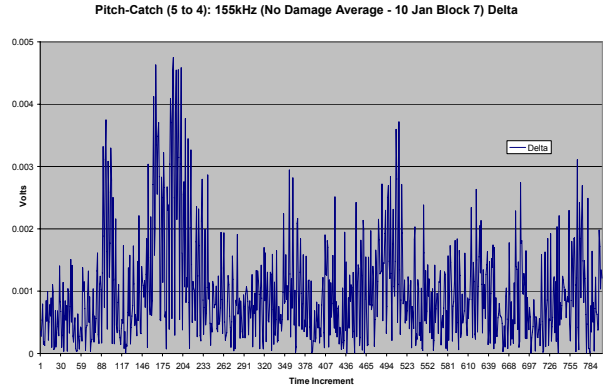
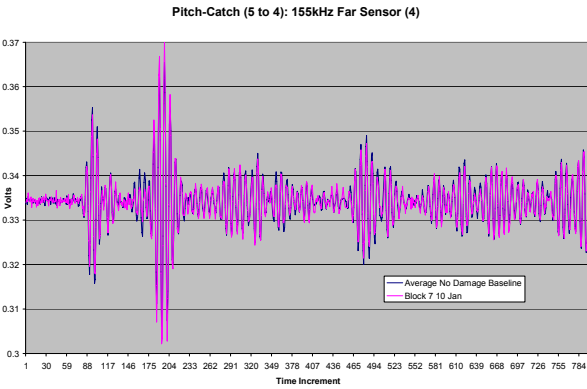
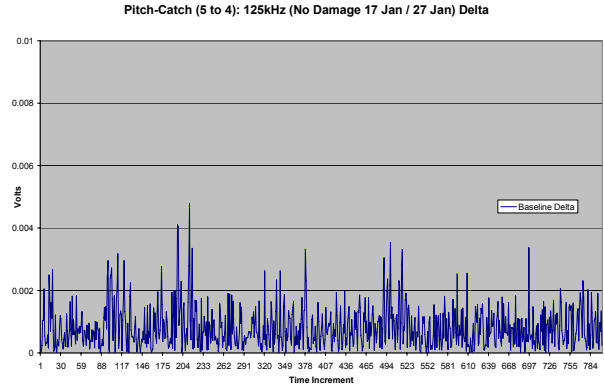
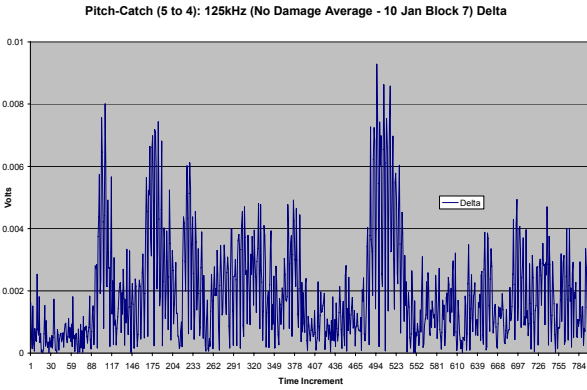

Pitch-Catch (Sensor 5 to 4): 16 Jan 07, Block 7 Centered, Offset, Small Face
No Damage Baseline

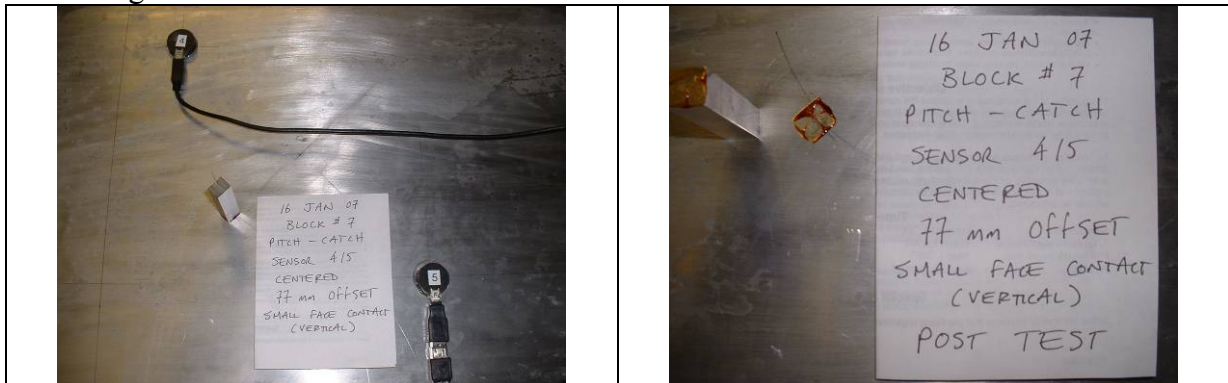

Pitch-Catch (5 to 4): 35 kHz Far Sensor (4)

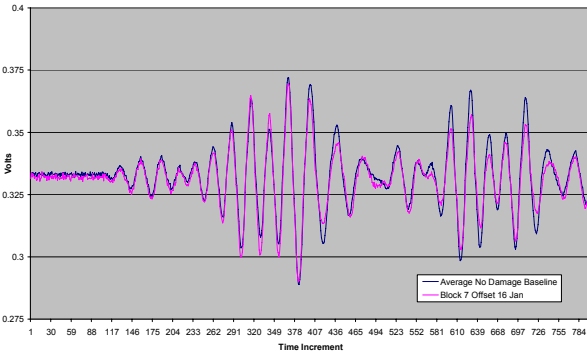

Pitch-Catch (5 to 4): 35kHz (No Damage Average - 16 Jan Block 7 Offset) Delta

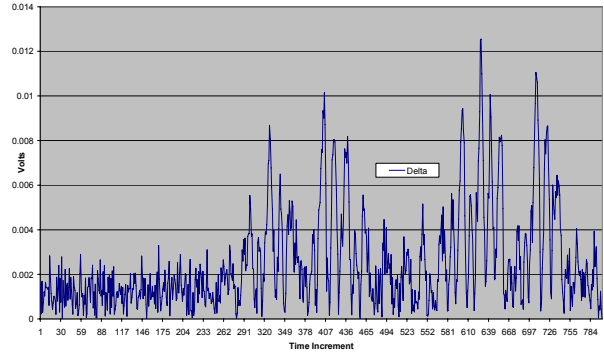

Pitch-Catch (5 to 4): 35kHz (No Damage 17 Jan / 27 Jan) Delta

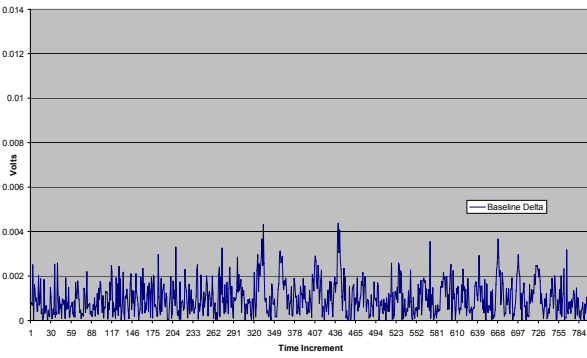

Pitch-Catch (5 to 4): 65kHz Far Sensor (4)

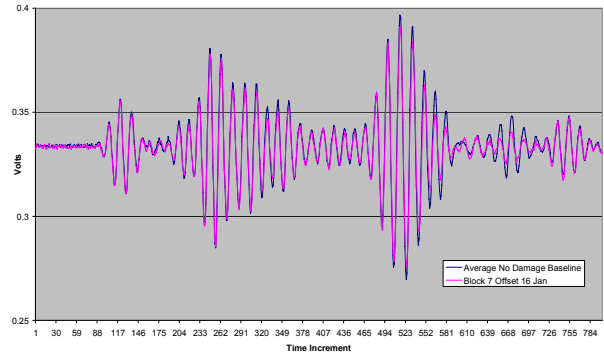

Pitch-Catch (5 to 4): 65kHz (No Damage Average - 16 Jan Block 7 Offset) Delta

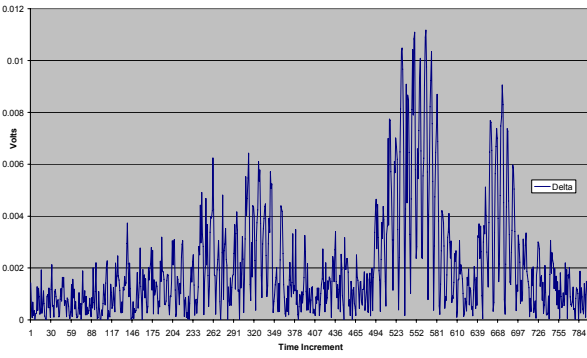

Pitch-Catch (5 to 4): 65kHz (No Damage 17 Jan / 27 Jan) Delta

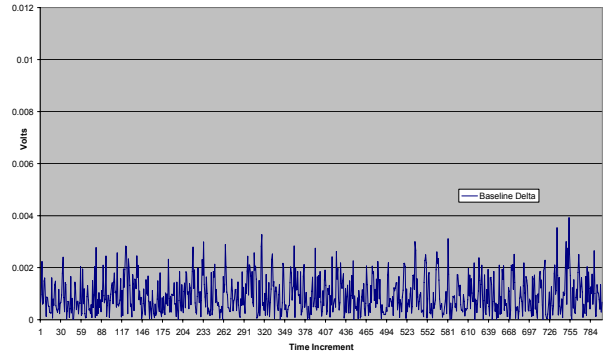

Pitch-Catch (5 to 4): 95kHz Far Sensor (4)

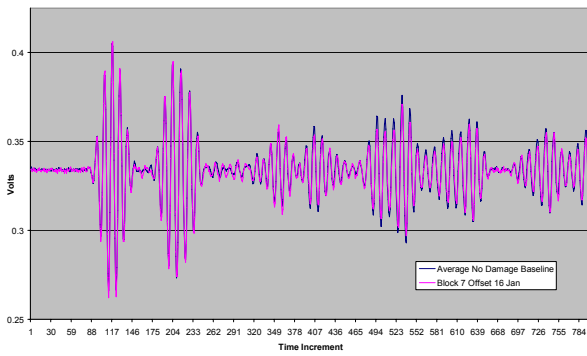

Pitch-Catch (5 to 4): 95kHz (No Damage Average - 16 Jan Block 7 Offset) Delta

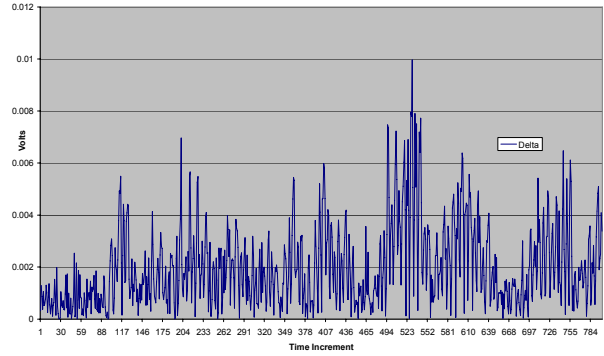

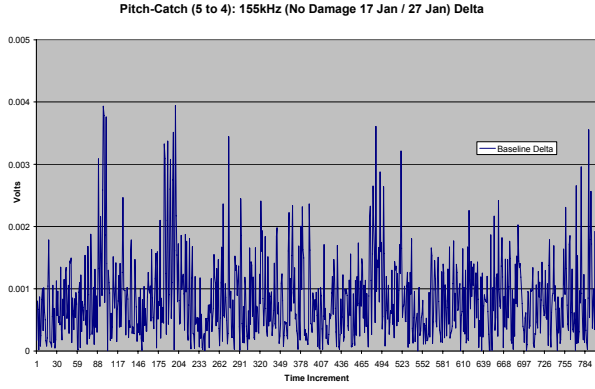
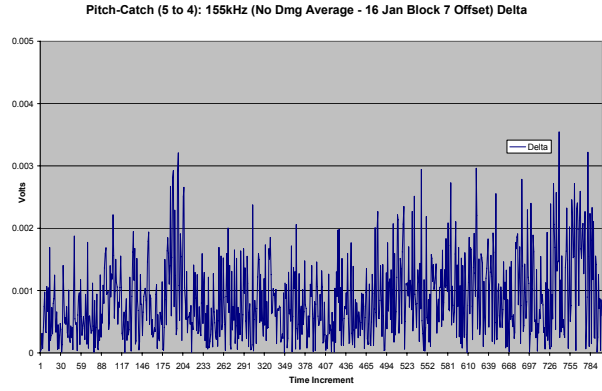
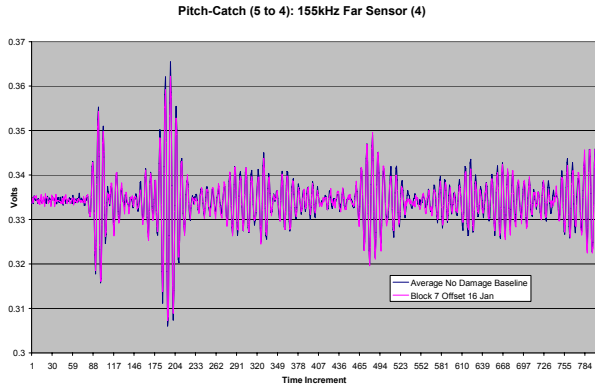
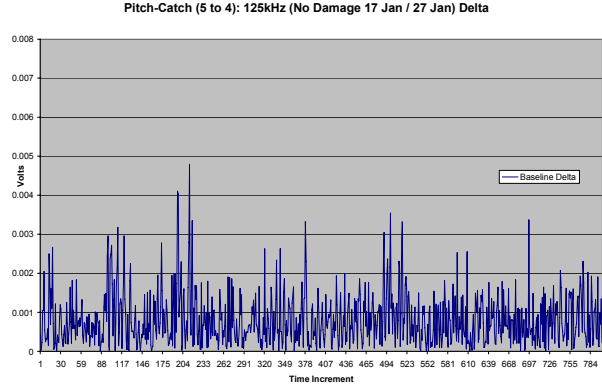
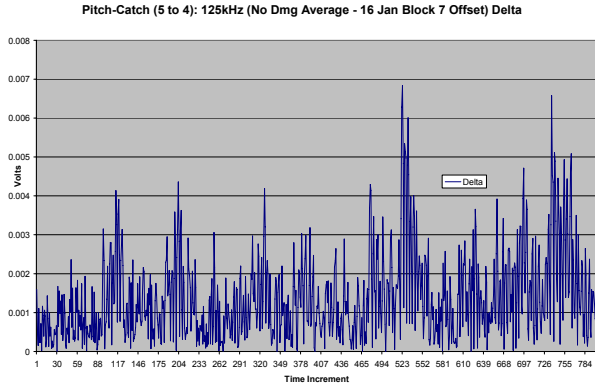
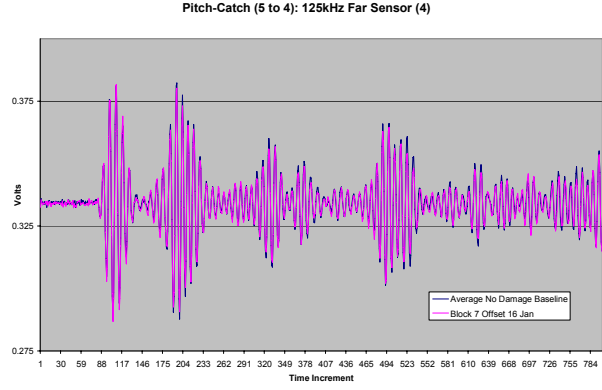
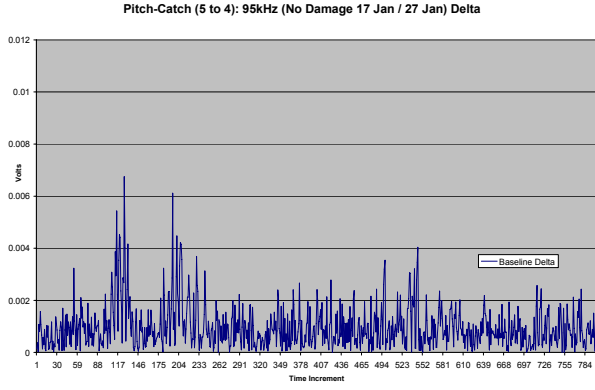

Pitch-Catch (Sensor 5 to 4): 27 Jan 07, Damage 3 – 3mm Gouge, Centered
 No Damage Baseline

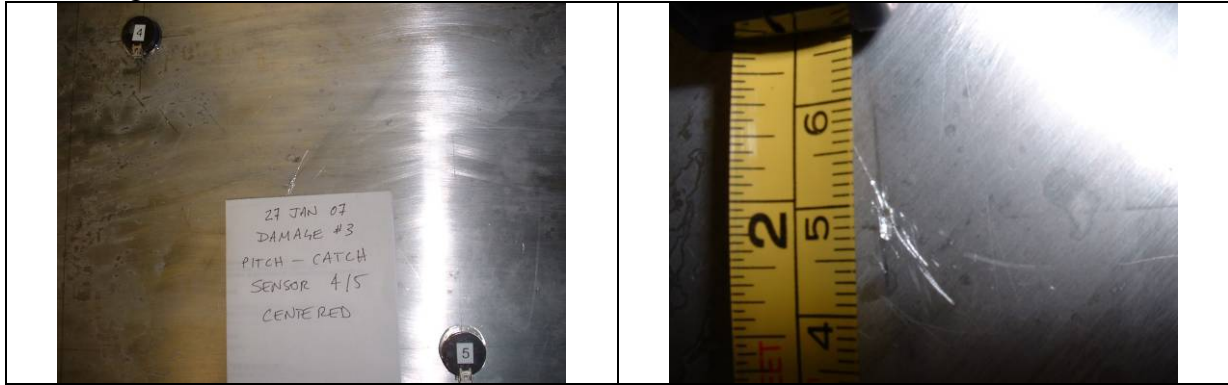

Pitch-Catch (5 to 4): 35 kHz Far Sensor (4)

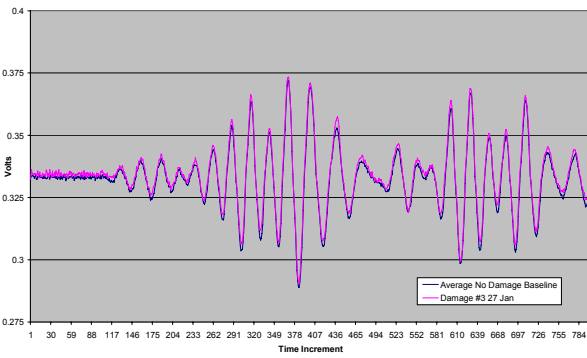

Pitch-Catch (5 to 4): 35kHz (No Damage Average - 27 Jan Damage #3) Delta

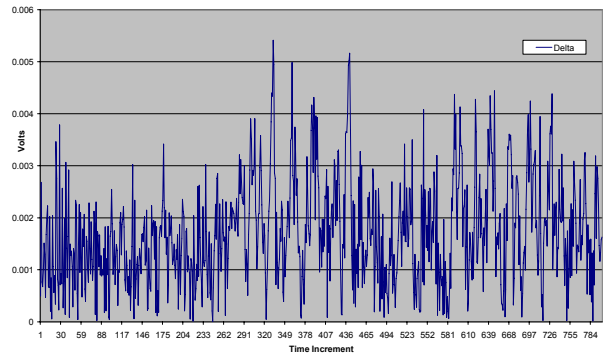

Pitch-Catch (5 to 4): 35kHz (No Damage 17 Jan / 27 Jan) Delta

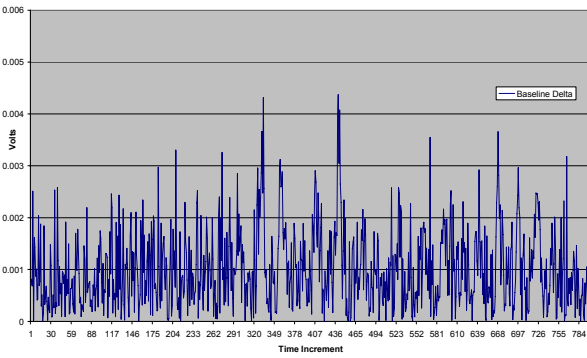

Pitch-Catch (5 to 4): 65kHz Far Sensor (4)

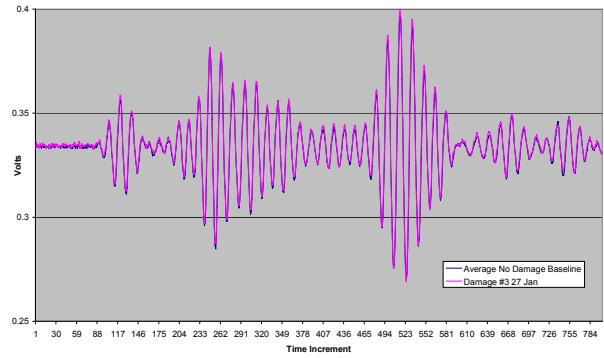

Pitch-Catch (5 to 4): 65kHz (No Damage Average - 27 Jan Damage #3) Delta

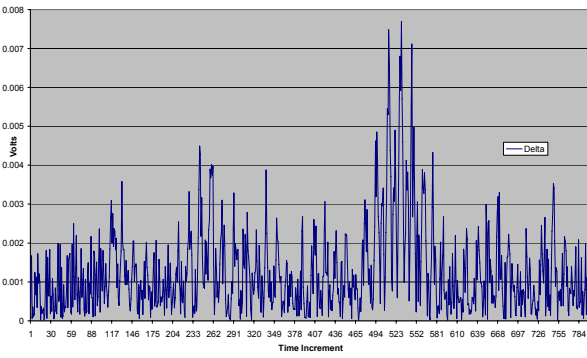

Pitch-Catch (5 to 4): 65kHz (No Damage 17 Jan / 27 Jan) Delta

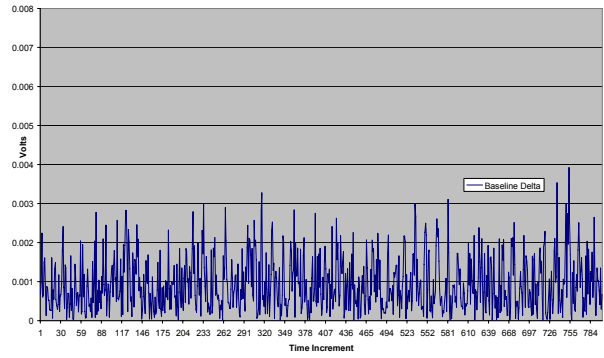

Pitch-Catch (5 to 4): 95kHz Far Sensor (4)

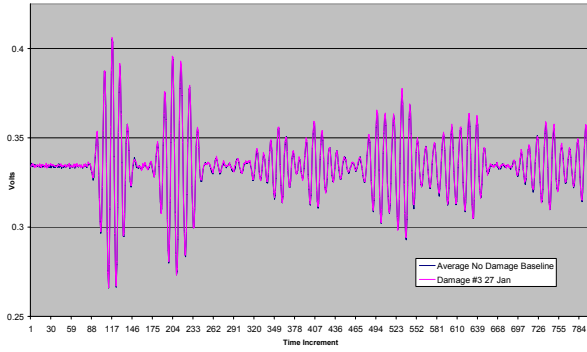

Pitch-Catch (5 to 4): 95kHz (No Damage Average - 27 Jan Damage #3) Delta

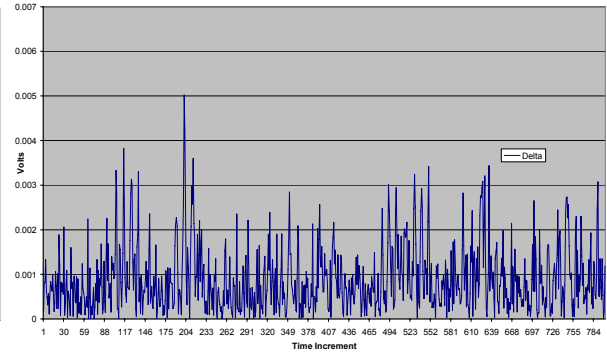

Pitch-Catch (5 to 4): 95kHz (No Damage 17 Jan / 27 Jan) Delta

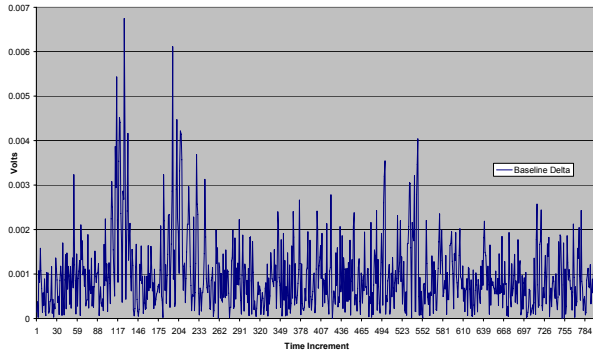

Pitch-Catch (5 to 4): 125kHz Far Sensor (4)

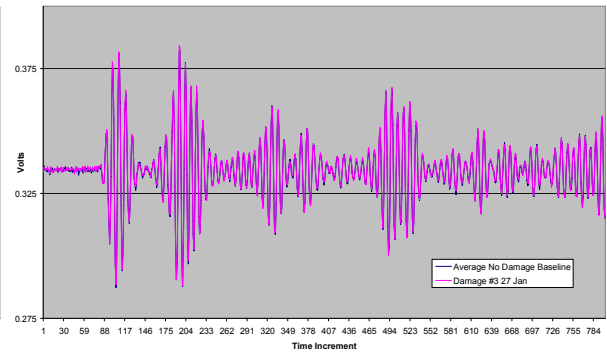

Pitch-Catch (5 to 4): 125kHz (No Damage Average - 27 Jan Damage #3) Delta

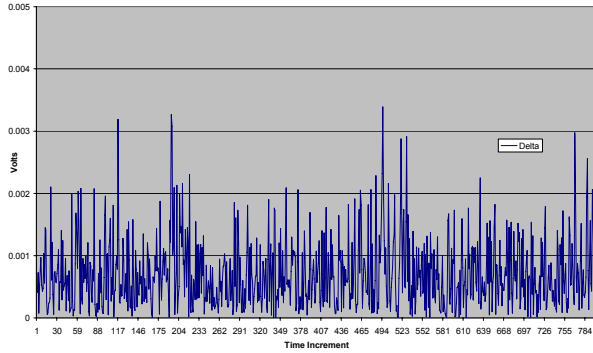

Pitch-Catch (5 to 4): 125kHz (No Damage 17 Jan / 27 Jan) Delta

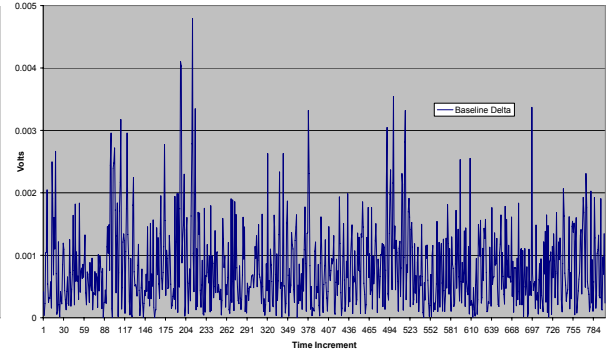

Pitch-Catch (5 to 4): 155kHz Far Sensor (4)

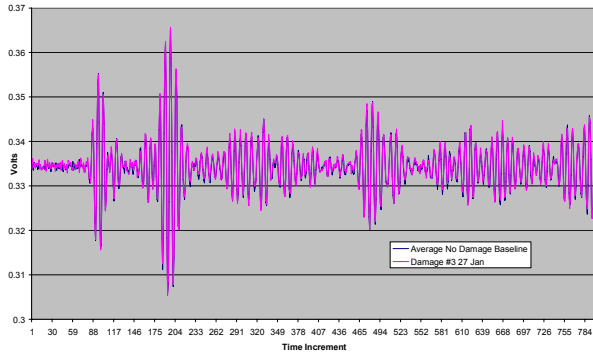

Pitch-Catch (5 to 4): 155kHz (No Damage Average - 27 Jan Damage #3) Delta

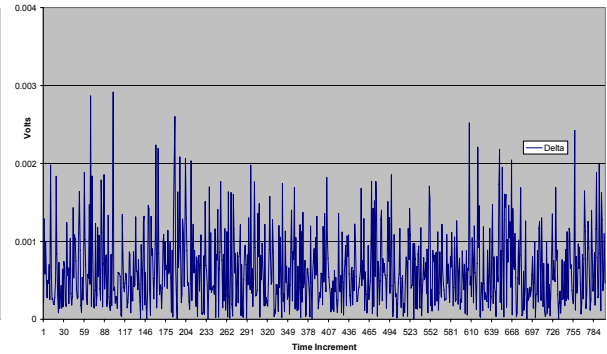

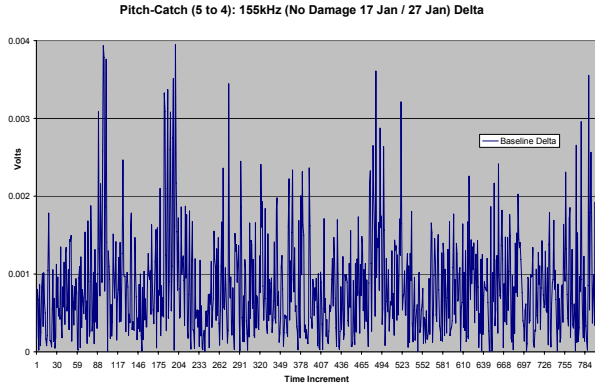

Pitch-Catch (Sensor 5 to 4): 29 Jan 07, Damage 3 – 3mm Gouge, Centered
No Damage Baseline

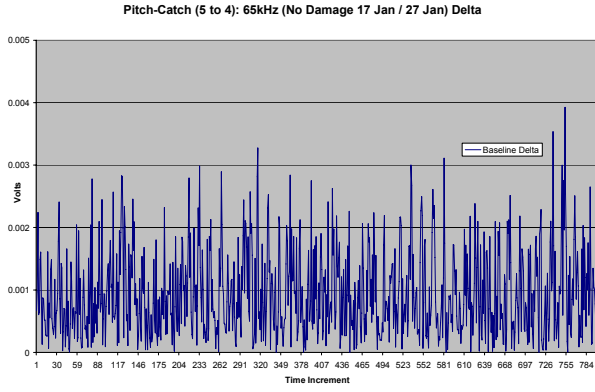
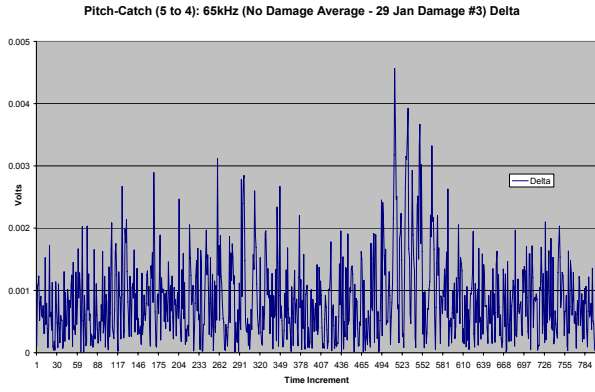
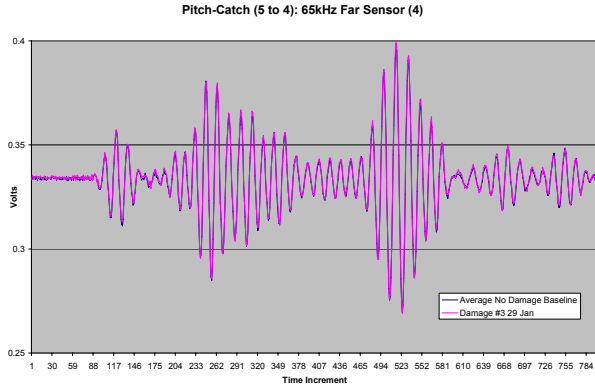
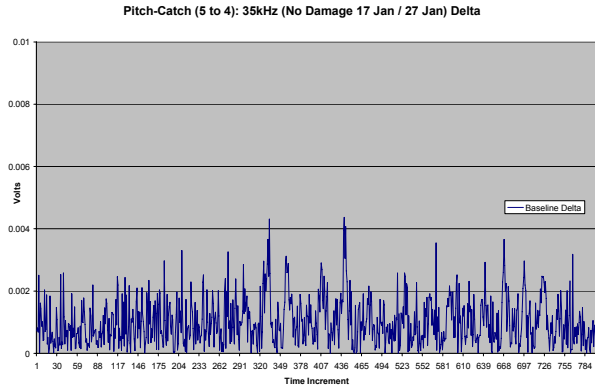
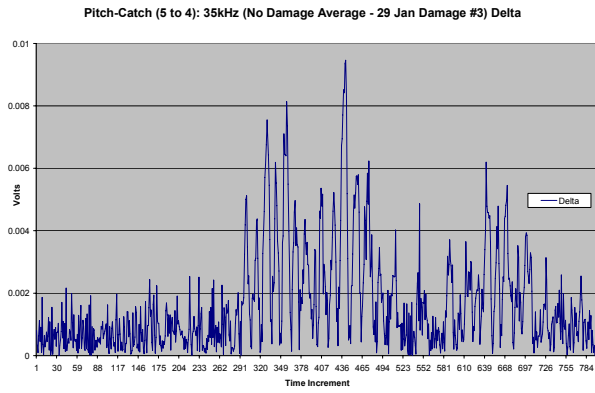
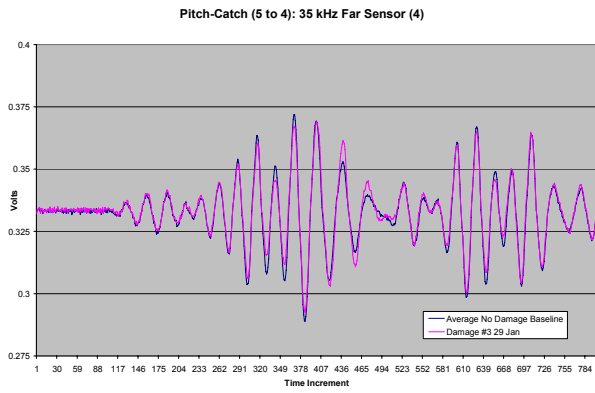

Pitch-Catch (5 to 4): 95kHz Far Sensor (4)

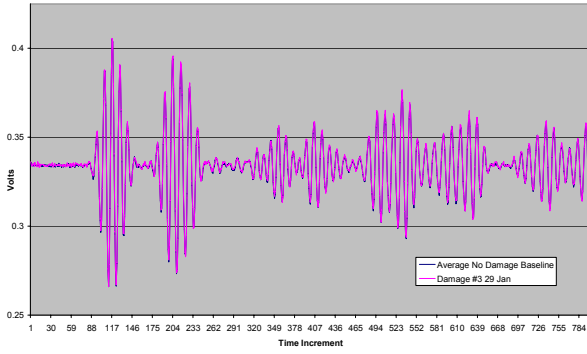

Pitch-Catch (5 to 4): 95kHz (No Damage Average - 29 Jan Damage #3) Delta

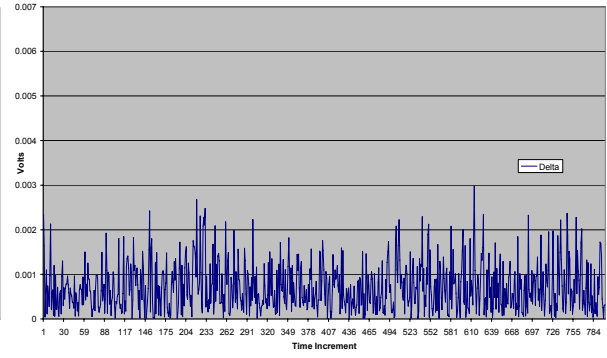

Pitch-Catch (5 to 4): 95kHz (No Damage 17 Jan / 27 Jan) Delta

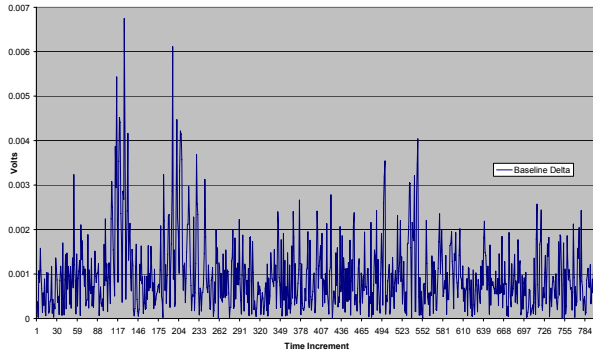

Pitch-Catch (5 to 4): 125kHz Far Sensor (4)

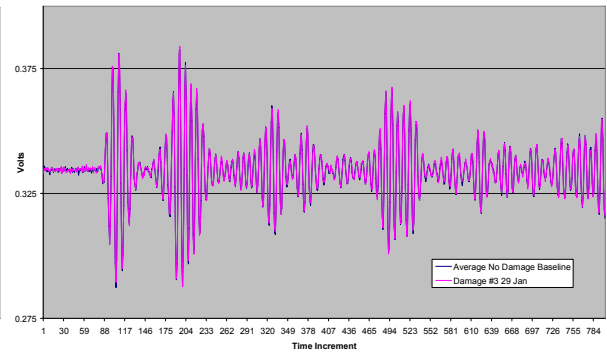

Pitch-Catch (5 to 4): 125kHz (No Damage Average - 29 Jan Damage #3) Delta

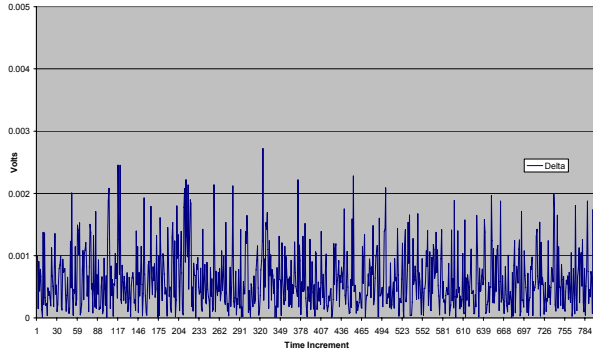

Pitch-Catch (5 to 4): 125kHz (No Damage 17 Jan / 27 Jan) Delta

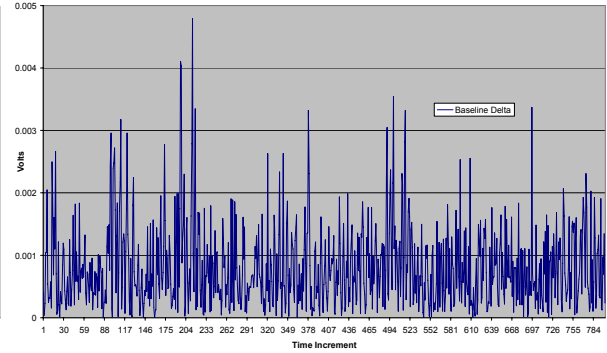

Pitch-Catch (5 to 4): 155kHz Far Sensor (4)

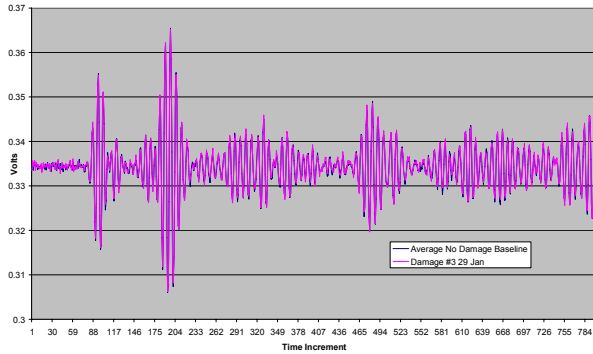

Pitch-Catch (5 to 4): 155kHz (No Damage Average - 29 Jan Damage #3) Delta

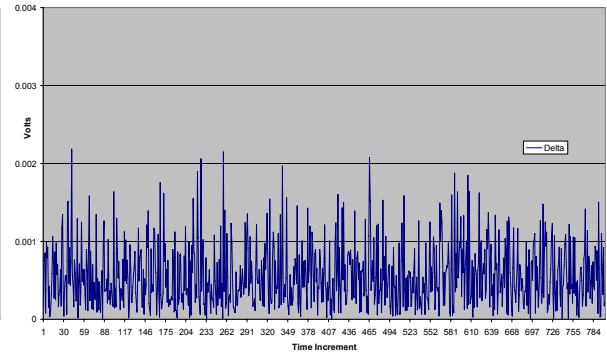

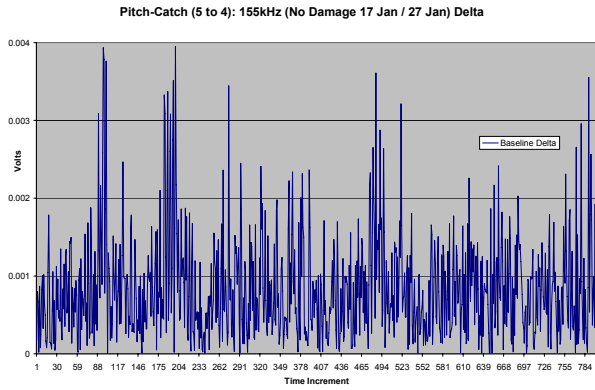

Pitch-Catch (Sensor 5 to 4): 29 Jan 07, Damage 4 – Punch Into Damage 3, Centered Damage 3 Baseline

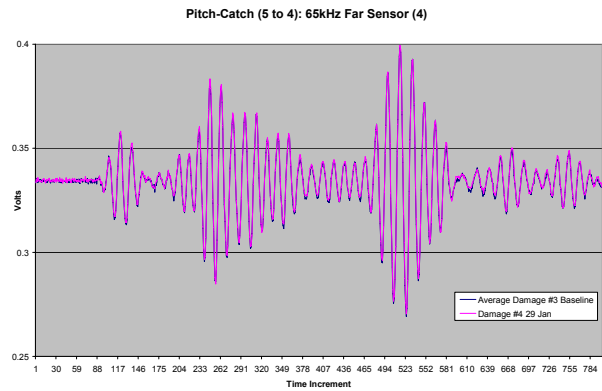
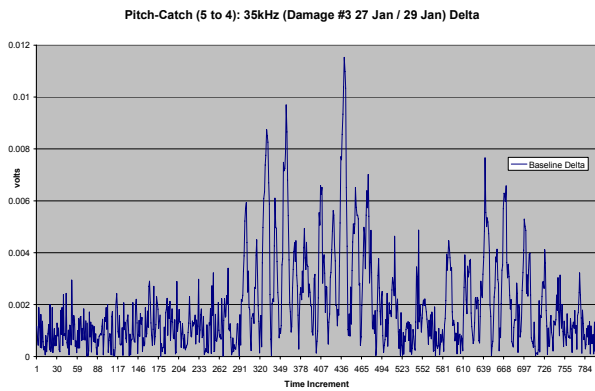
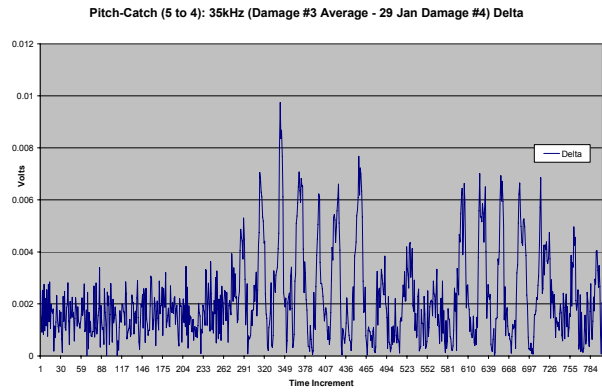
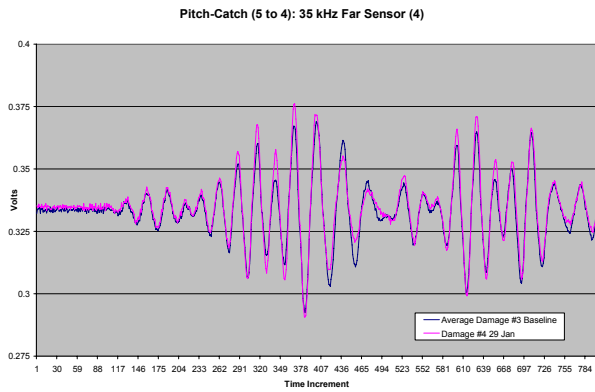
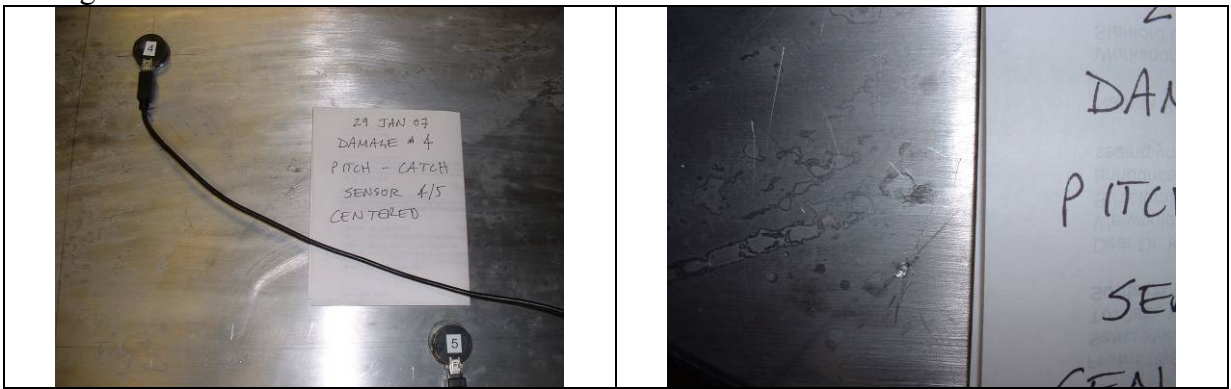

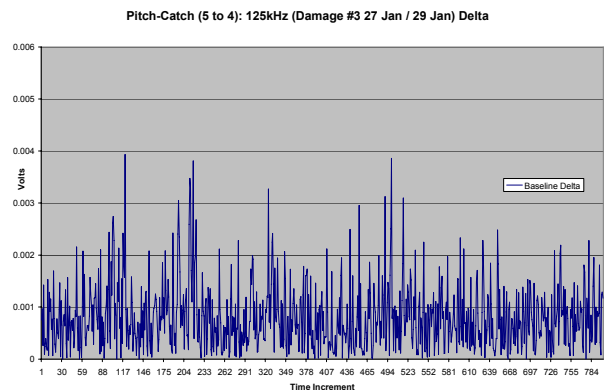
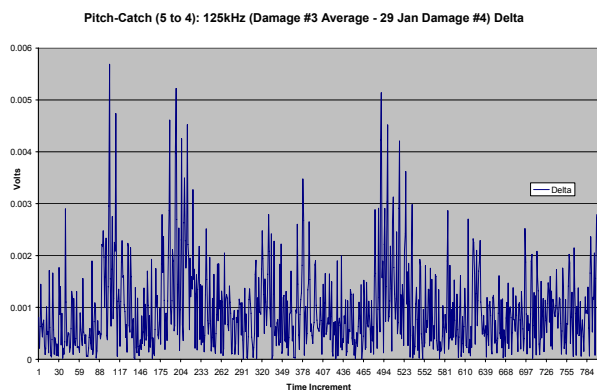
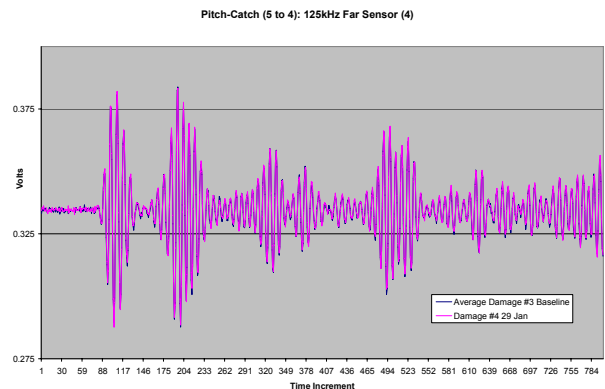
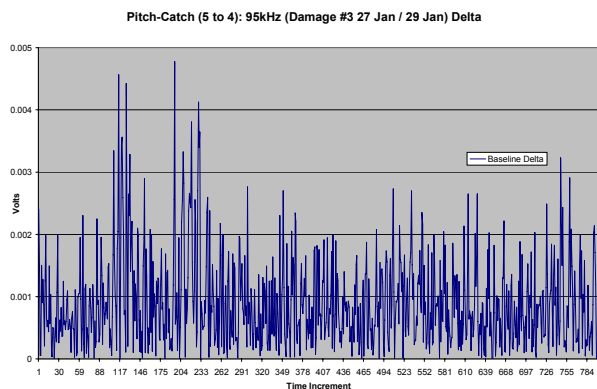
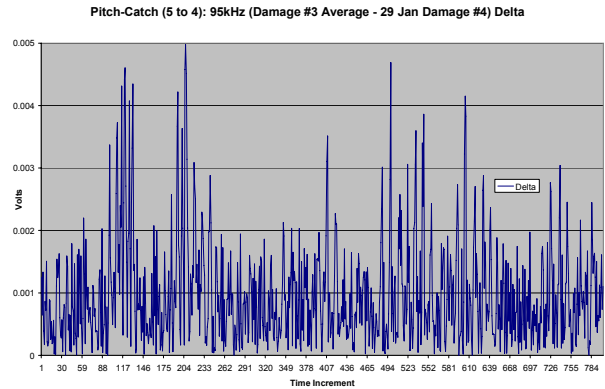
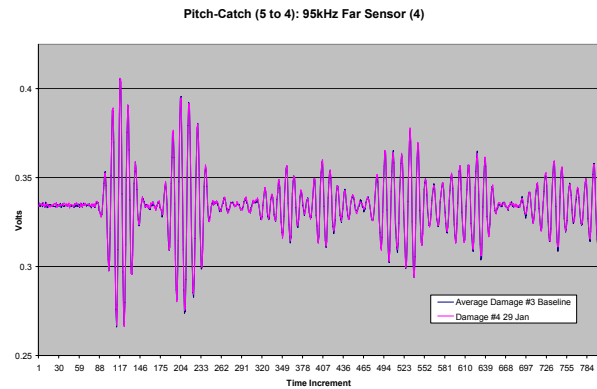
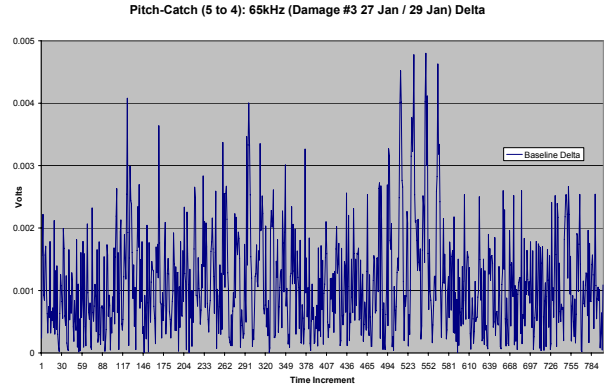
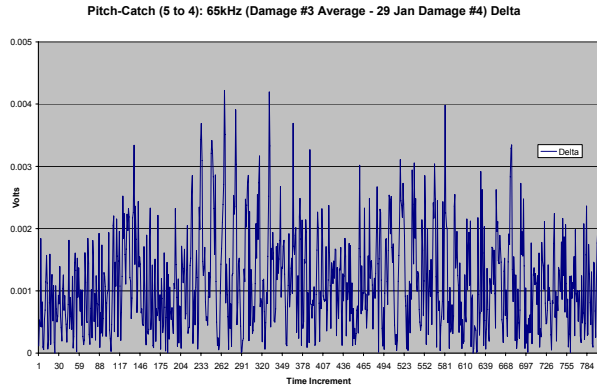

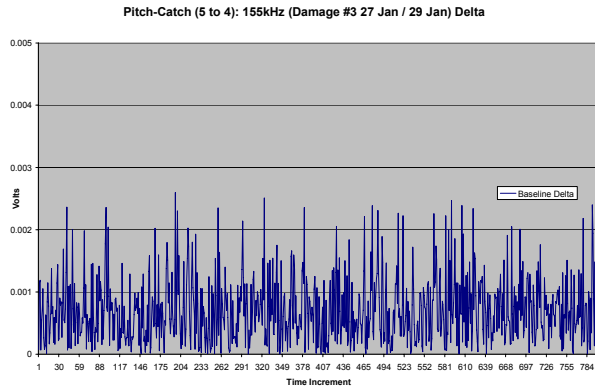
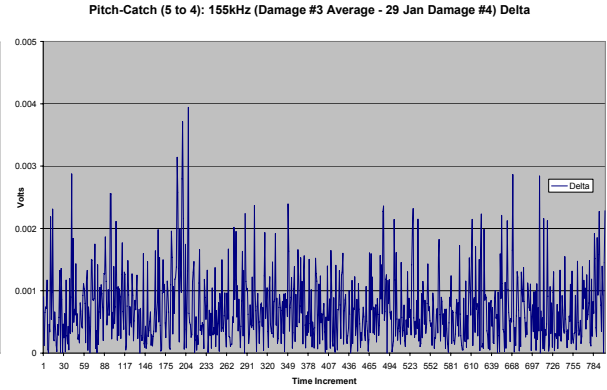
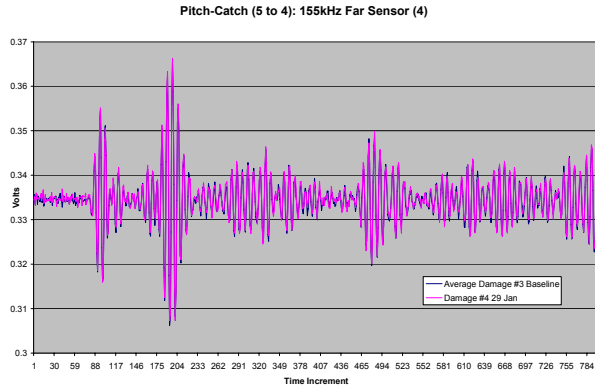

Pitch-Catch (Sensor 5 to 4): 30 Jan 07, Damage 4 – Punch Into Damage 3, Centered Damage 3 Baseline

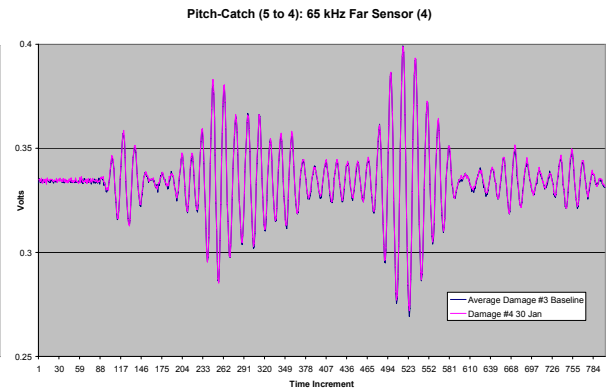
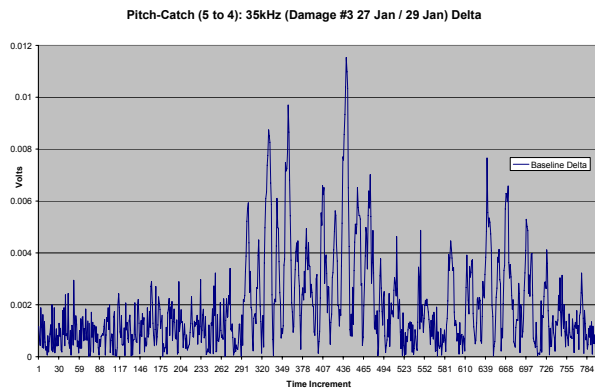
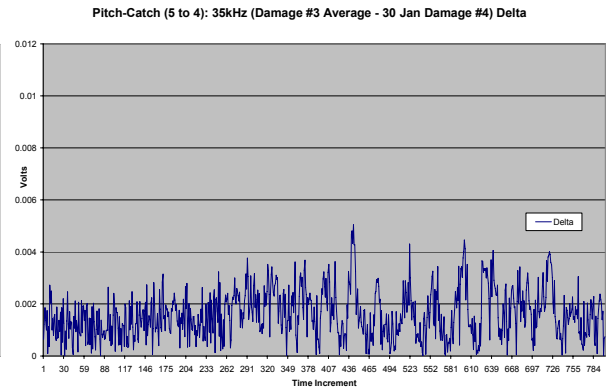
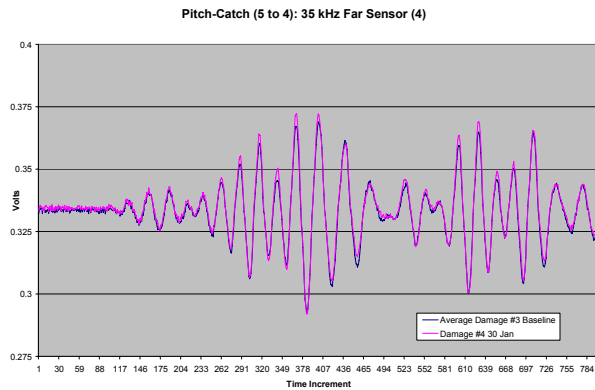

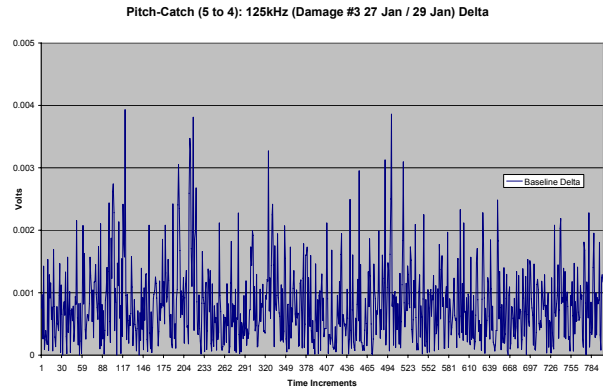
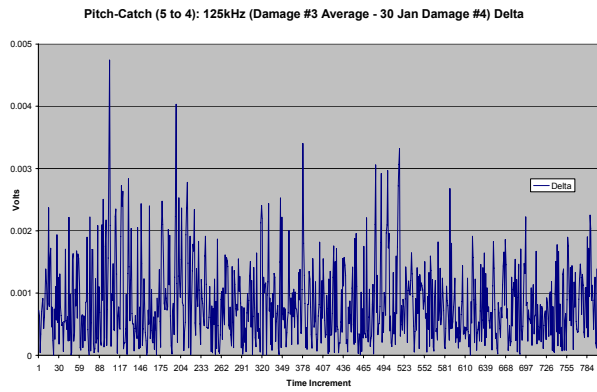
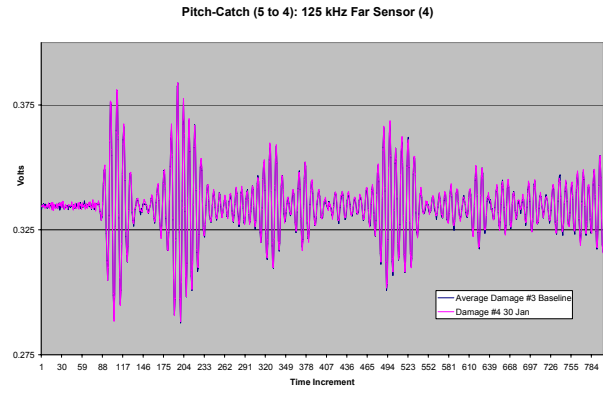
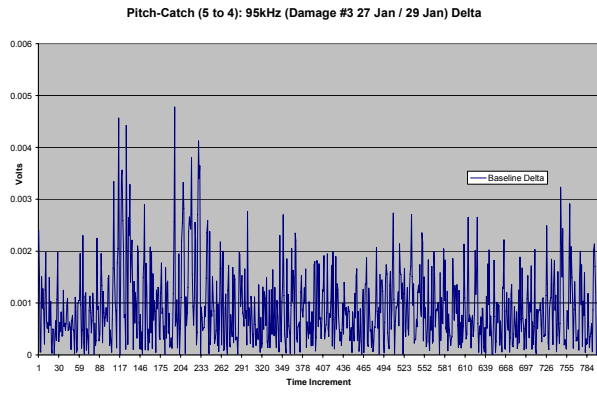
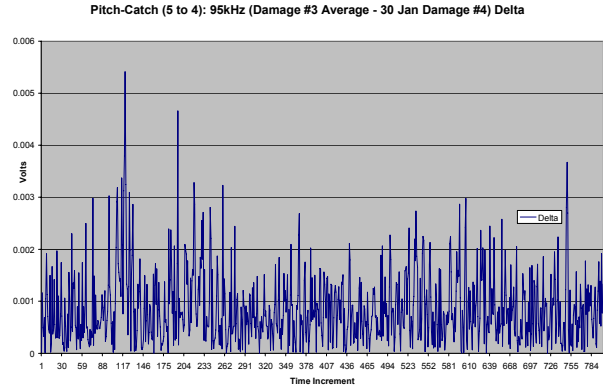
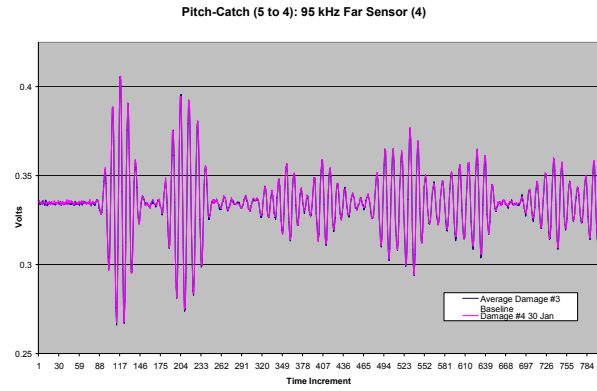
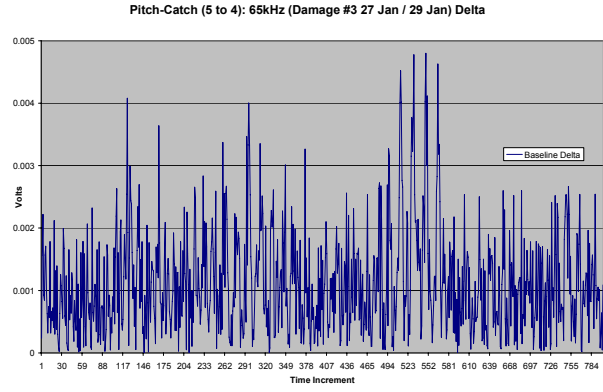
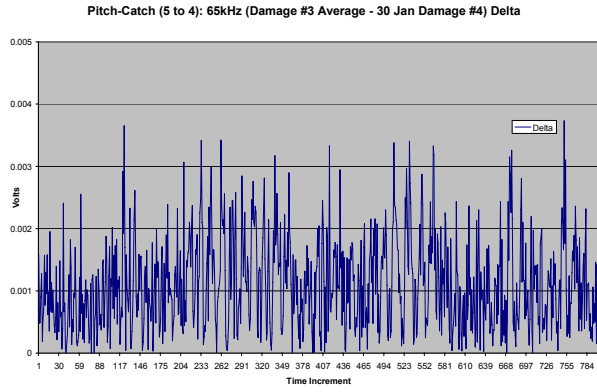

Pitch-Catch (5 to 4): 155 kHz Far Sensor (4)

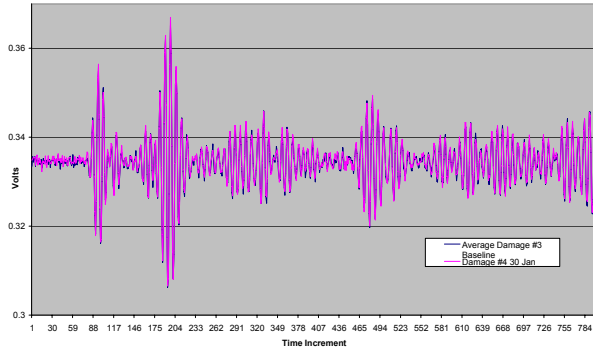

Pitch-Catch (5 to 4): 155kHz (Damage #3 Average - 30 Jan Damage #4) Delta

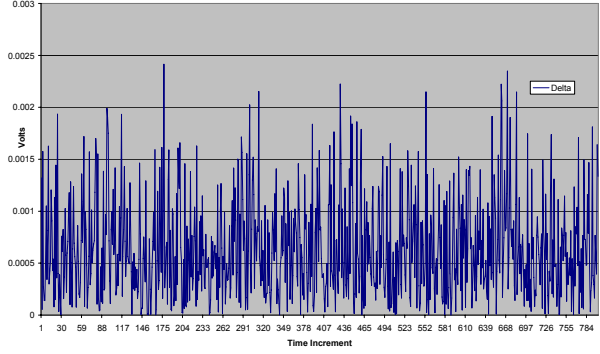

Pitch-Catch (5 to 4): 155kHz (Damage #3 27 Jan / 29 Jan) Delta

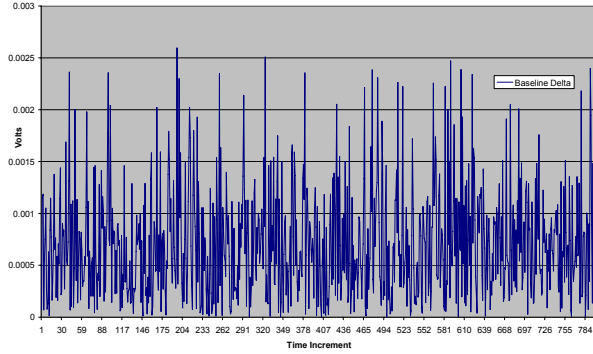

Pitch-Catch (Sensor 5 to 4): 30 Jan 07, Damage 5 – 5mm Cross Gouge, Centered
Damage 4 Baseline



Pitch-Catch (5 to 4): 35 kHz Far Sensor (4)

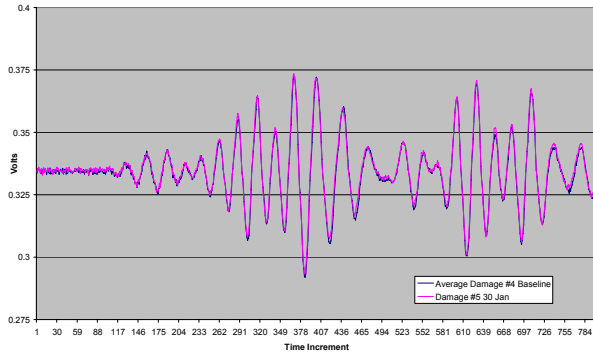

Pitch-Catch (5 to 4): 35kHz (Damage #4 Average - 30 Jan Damage #5) Delta

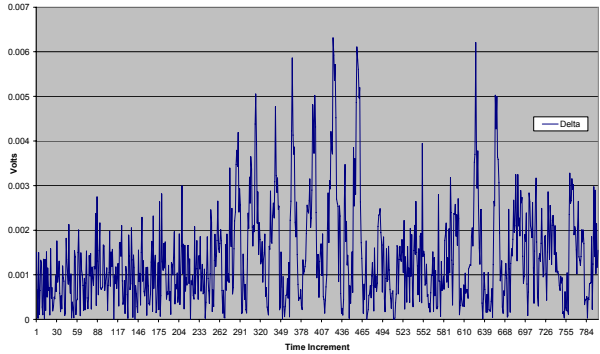

Pitch-Catch (5 to 4): 35kHz (Damage #4 29 Jan / 30 Jan) Delta

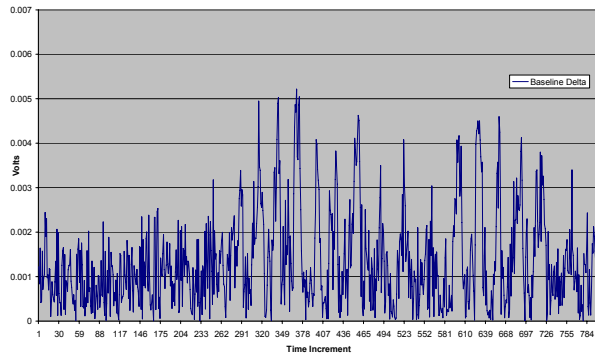

Pitch-Catch (5 to 4): 65 kHz Far Sensor (4)

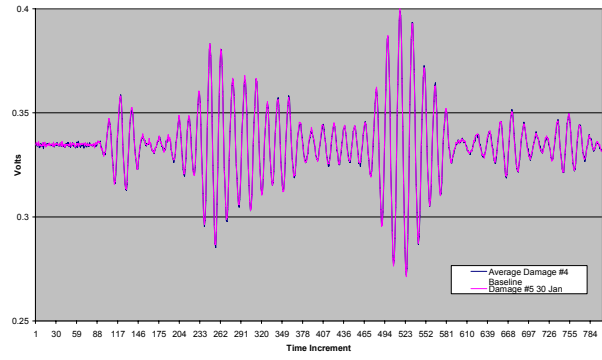

Pitch-Catch (5 to 4): 65kHz (Damage #4 Average - 30 Jan Damage #5) Delta

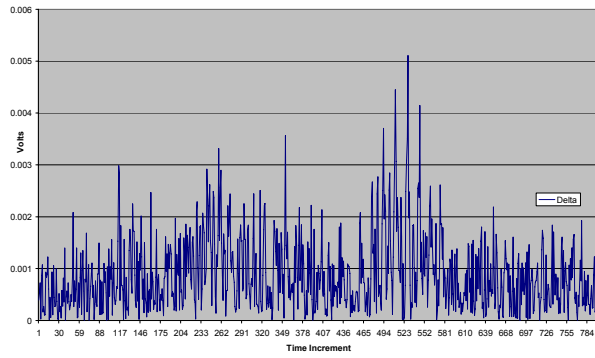

Pitch-Catch (5 to 4): 65kHz (Damage #4 29 Jan / 30 Jan) Delta

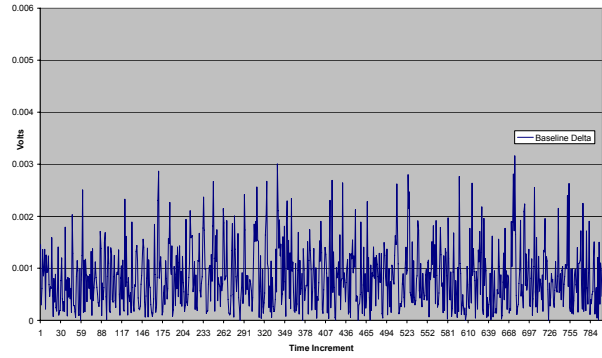

Pitch-Catch (5 to 4): 95 kHz Far Sensor (4)

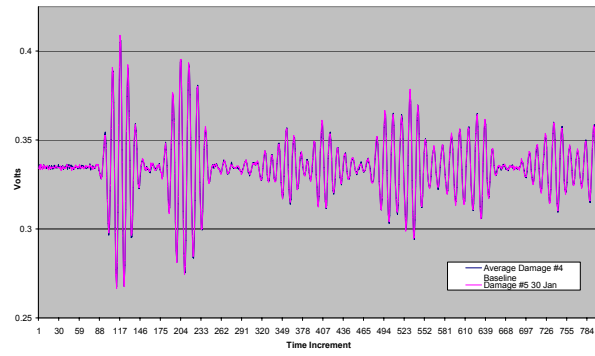

Pitch-Catch (5 to 4): 95kHz (Damage #4 Average - 30 Jan Damage #5) Delta

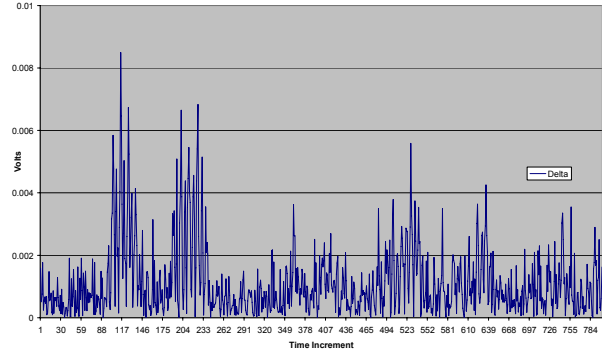

Pitch-Catch (5 to 4): 95kHz (Damage #4 29 Jan / 30 Jan) Delta

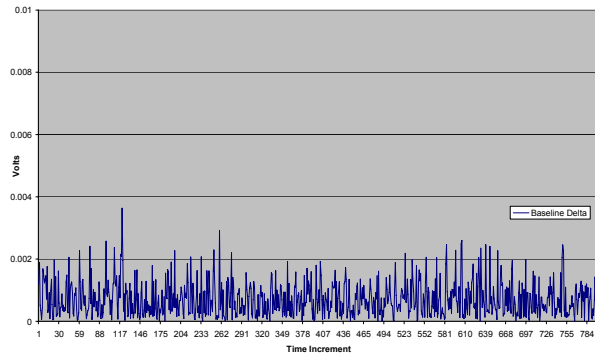

Pitch-Catch (5 to 4): 125 kHz Far Sensor (4)

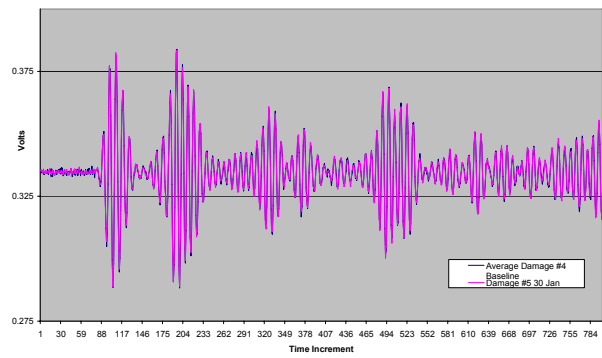

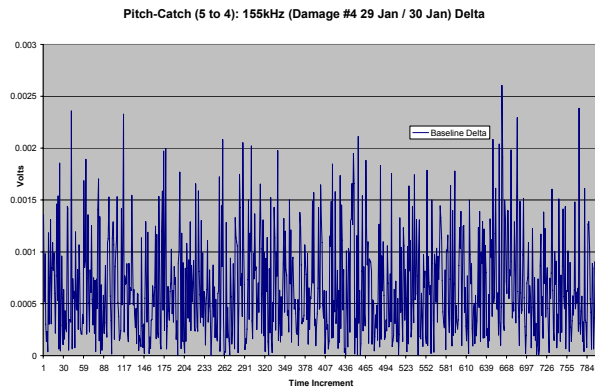
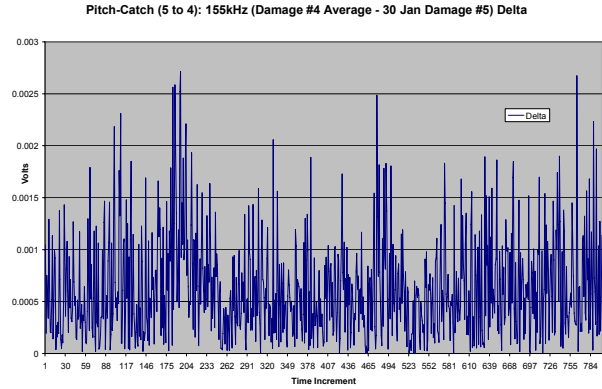
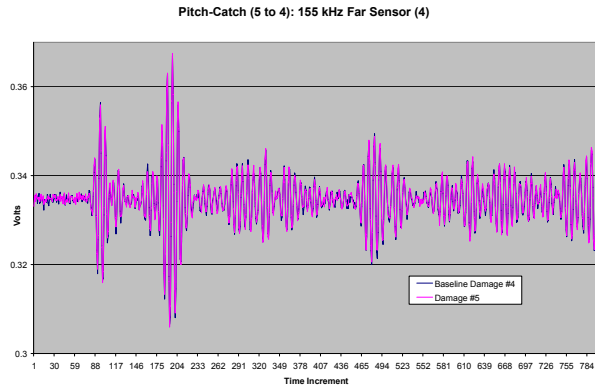
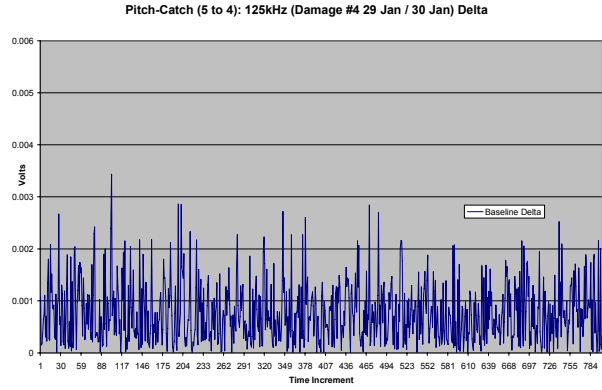
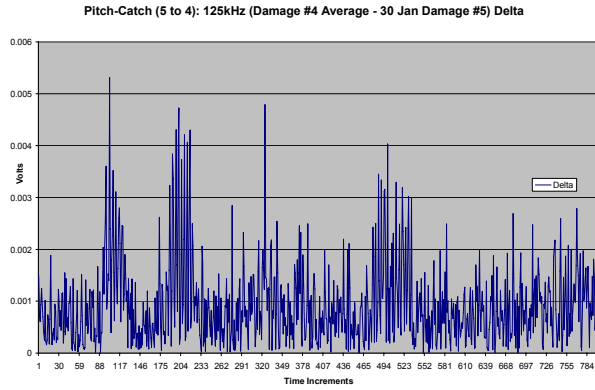

Pitch-Catch (Sensor 5 to 4): 30 Jan 07 Run 2, Damage 5 – 5mm Cross Gouge, Centered
Damage 4 Baseline

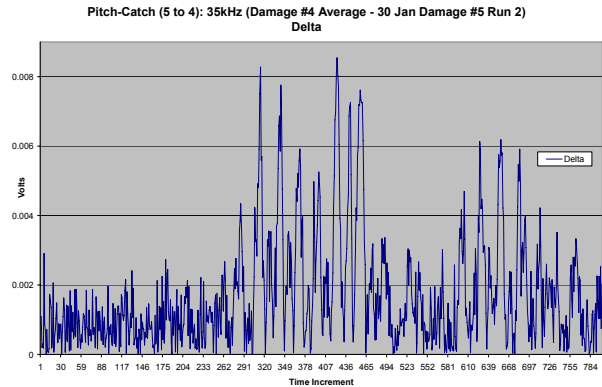
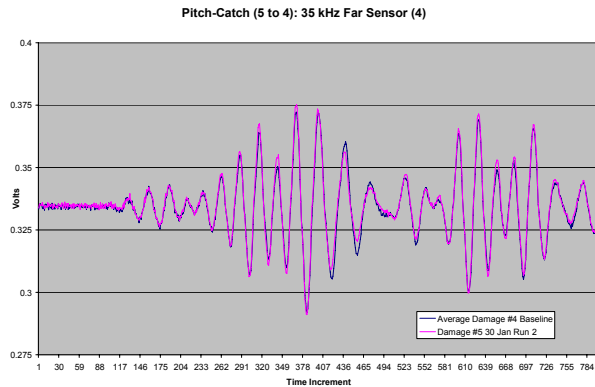

Pitch-Catch (5 to 4): 35kHz (Damage #4 29 Jan / 30 Jan) Delta

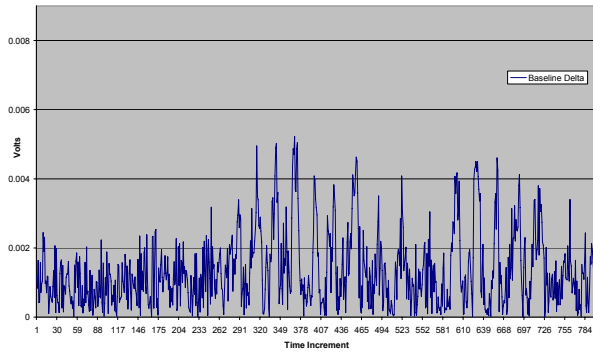

Pitch-Catch (5 to 4): 65 kHz Far Sensor (4)

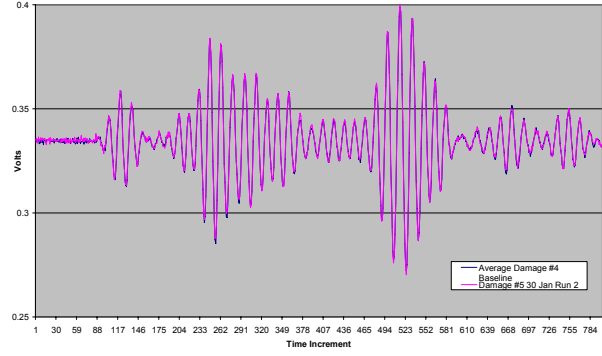

Pitch-Catch (5 to 4): 65kHz (Damage #4 Average - 30 Jan Damage #5 Run 2) Delta

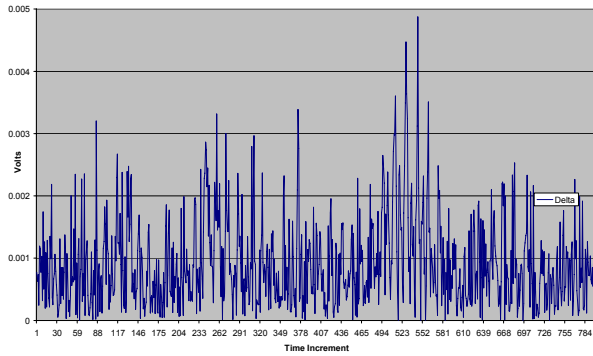

Pitch-Catch (5 to 4): 65kHz (Damage #4 29 Jan / 30 Jan) Delta

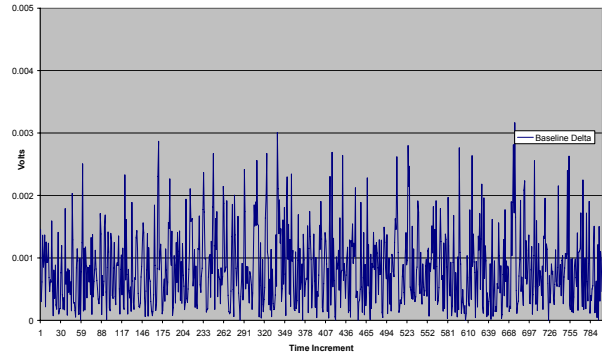

Pitch-Catch (5 to 4): 95 kHz Far Sensor (4)

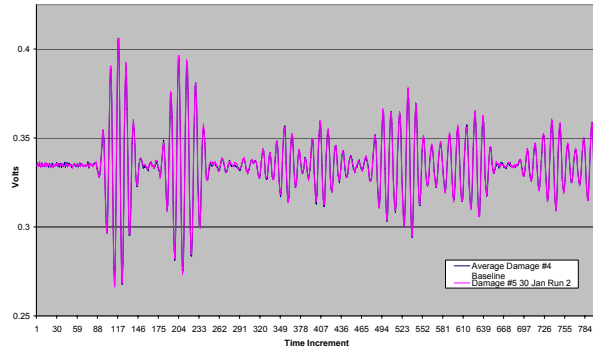

Pitch-Catch (5 to 4): 95kHz (Damage #4 Average - 30 Jan Damage #5 Run 2) Delta

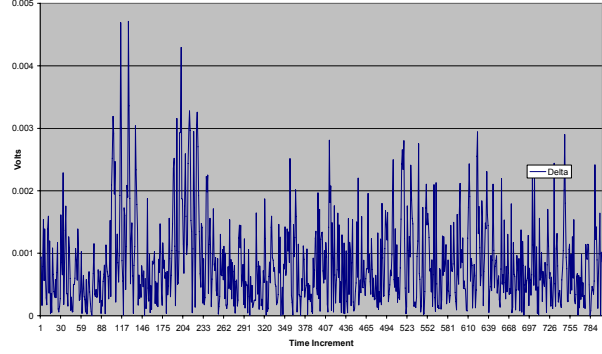

Pitch-Catch (5 to 4): 95kHz (Damage #4 29 Jan / 30 Jan) Delta

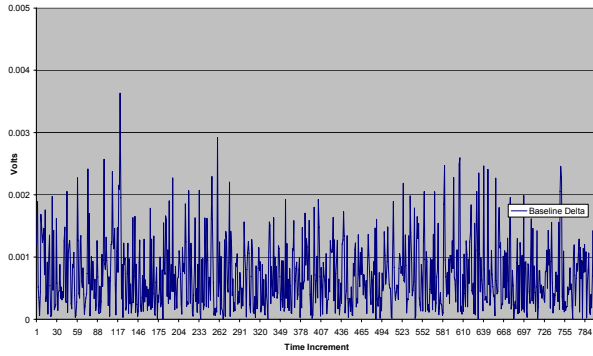

Pitch-Catch (5 to 4): 125 kHz Far Sensor (4)

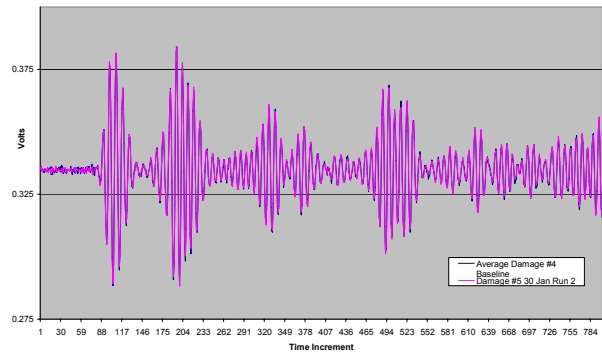

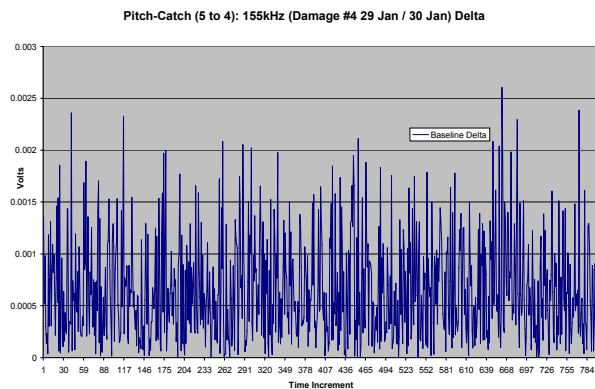
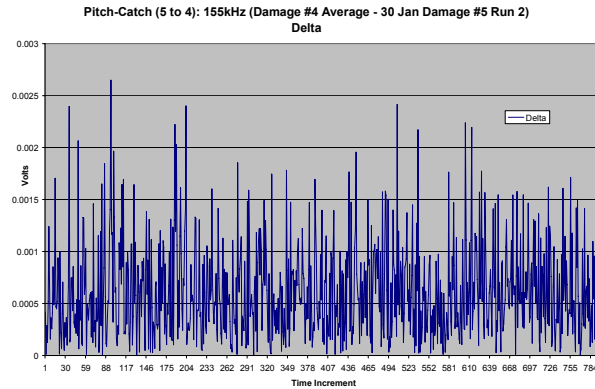
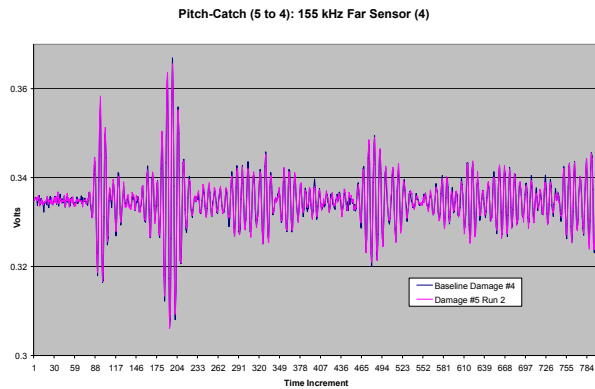
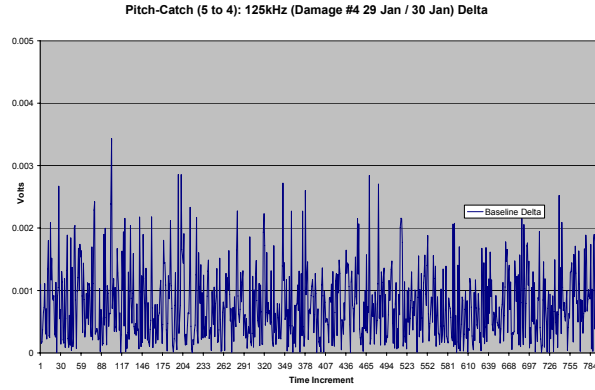
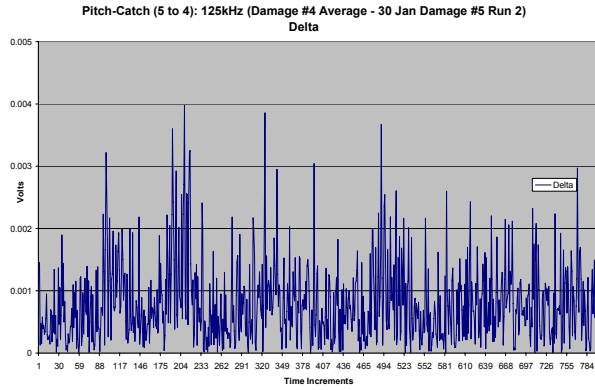

Pitch-Catch (Sensor 5 to 4): 31 Jan 07, Damage 6 – 1/16” Hole, Centered
Damage 5 Baseline

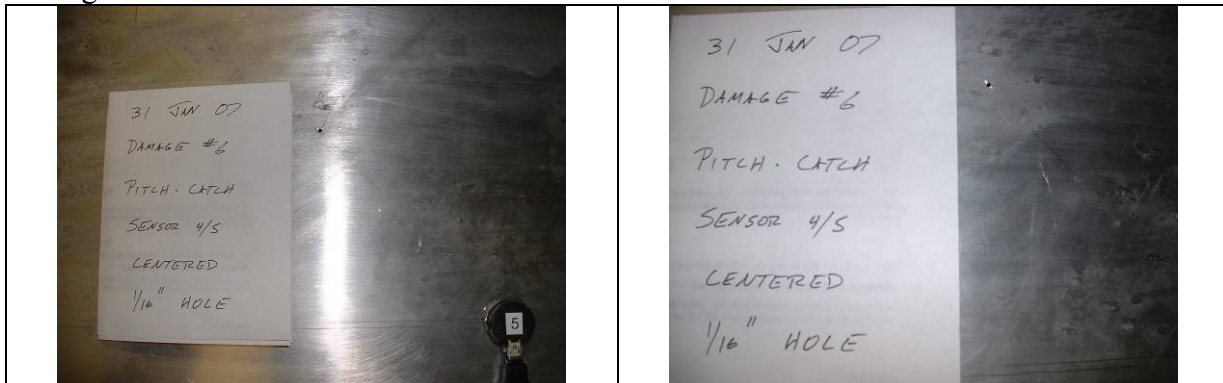

Pitch-Catch (5 to 4): 35 kHz Far Sensor (4)

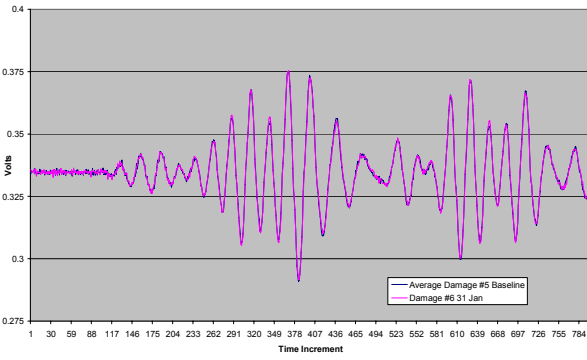

Pitch-Catch (5 to 4): 35 kHz (Damage #5 Average - 31 Jan Damage #6) Delta

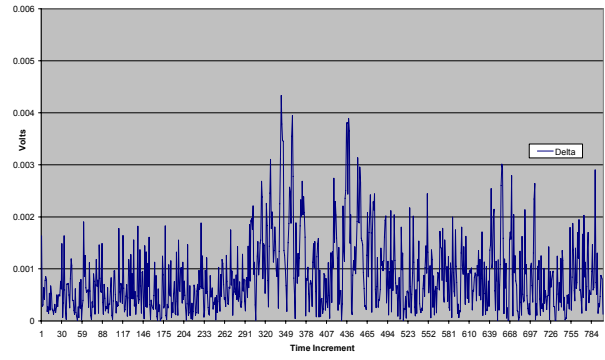

Pitch-Catch (5 to 4): 35 kHz (Damage #5 30 Jan / 30 Jan Run 2) Delta

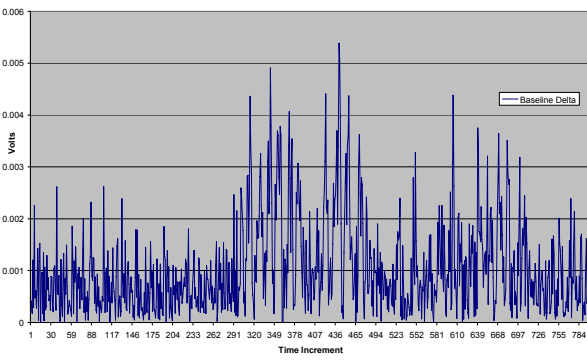

Pitch-Catch (5 to 4): 65 kHz Far Sensor (4)

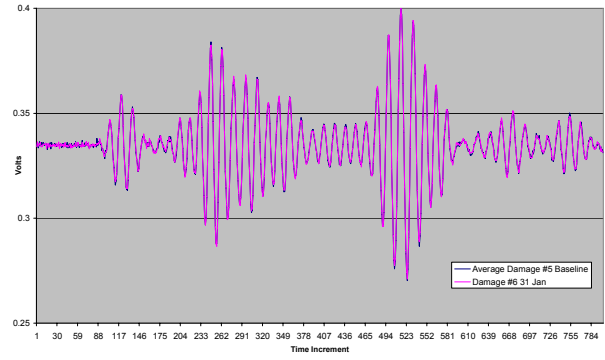

Pitch-Catch (5 to 4): 65 kHz (Damage #5 Average - 31 Jan Damage #6) Delta

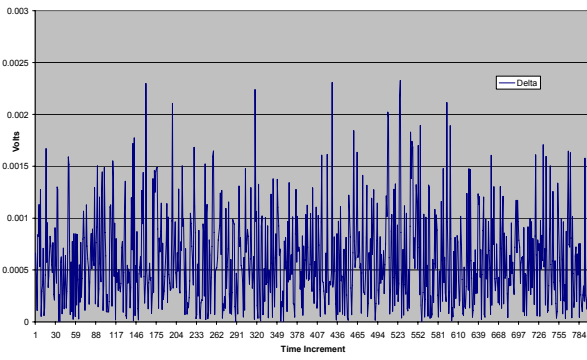

Pitch-Catch (5 to 4): 65 kHz (Damage #5 30 Jan / 30 Jan Run 2) Delta

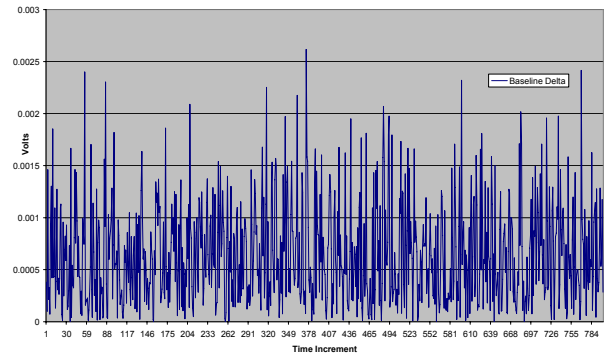

Pitch-Catch (5 to 4): 95 kHz Far Sensor (4)

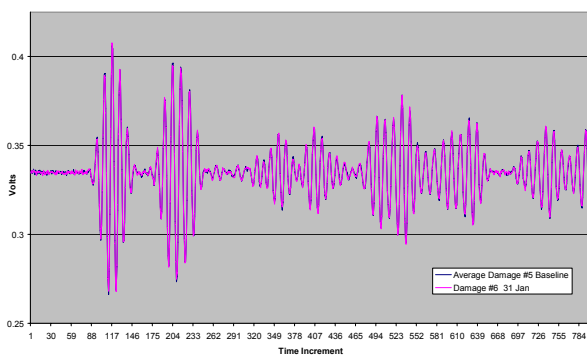

Pitch-Catch (5 to 4): 95 kHz (Damage #5 Average - 31 Jan Damage #6) Delta

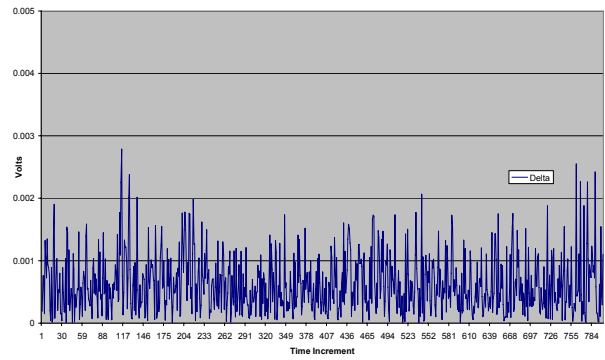

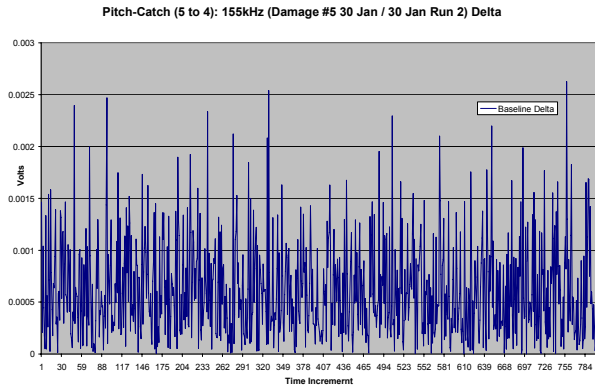
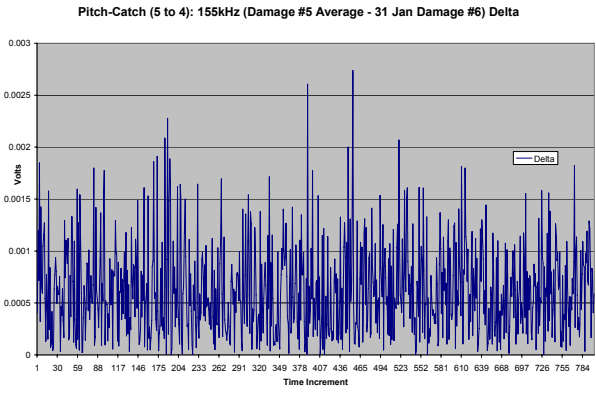
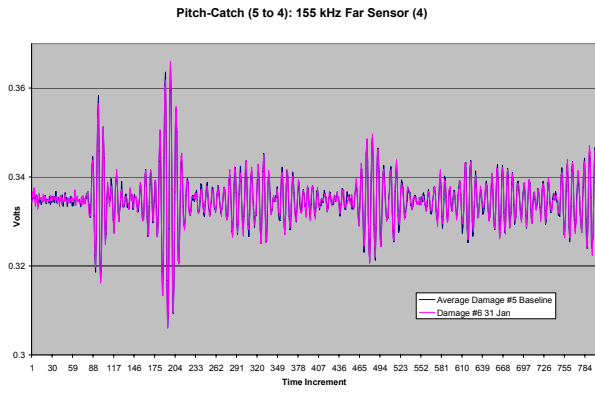
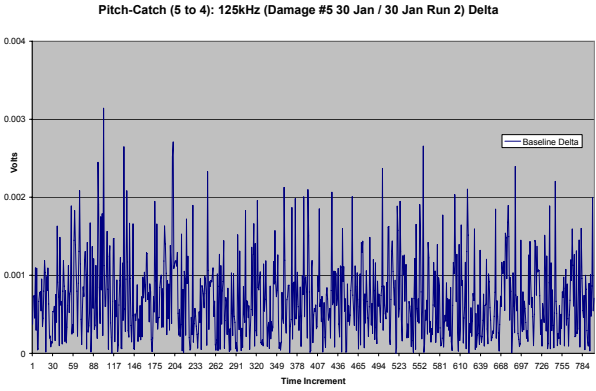
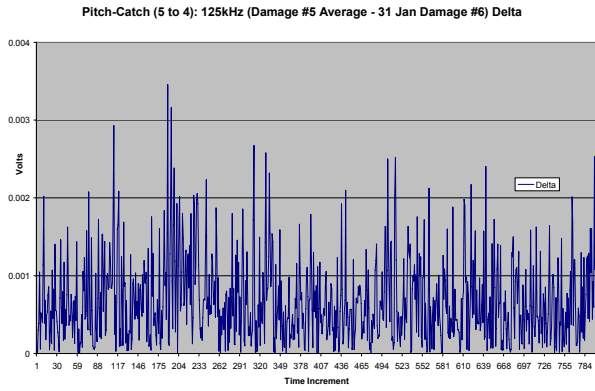
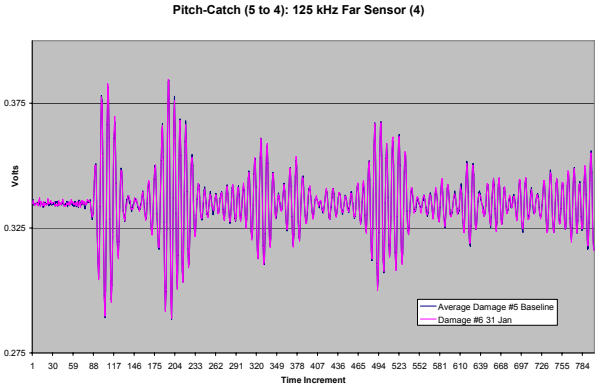
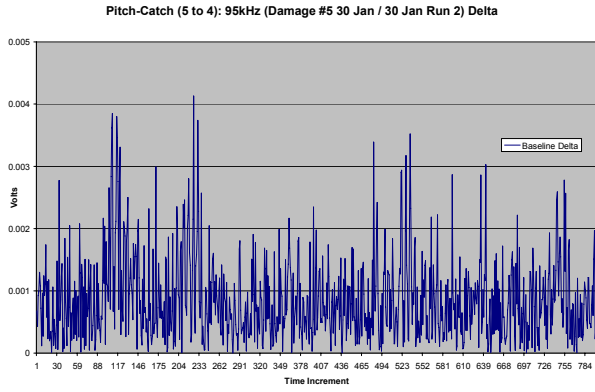

Pitch-Catch (Sensor 5 to 4): 31 Jan 07 Run 2, Damage 6 – 1/16” Hole, Centered Damage 5 Baseline

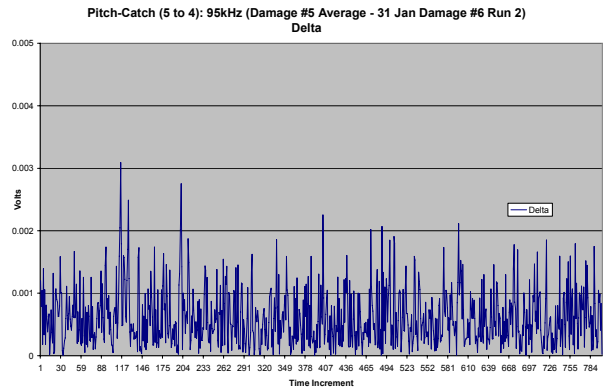
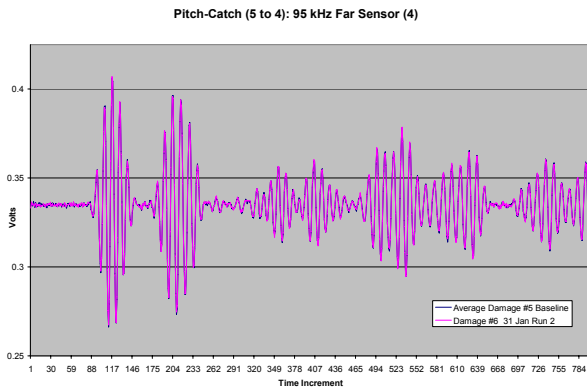
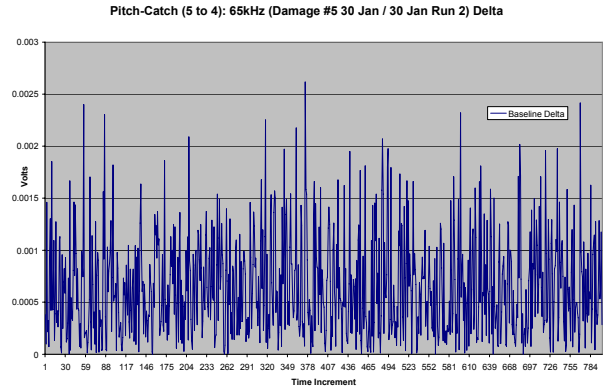
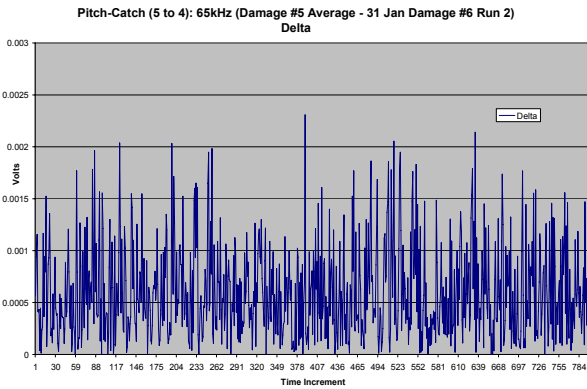
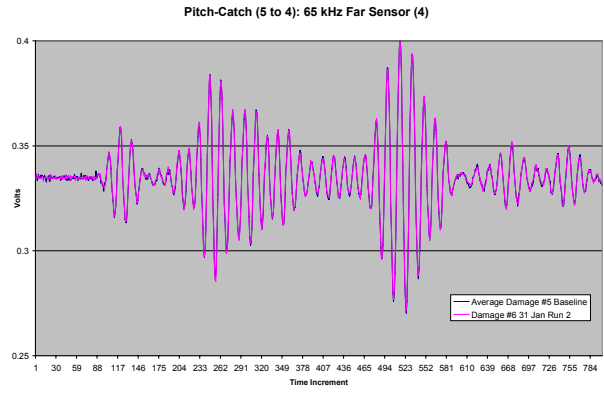
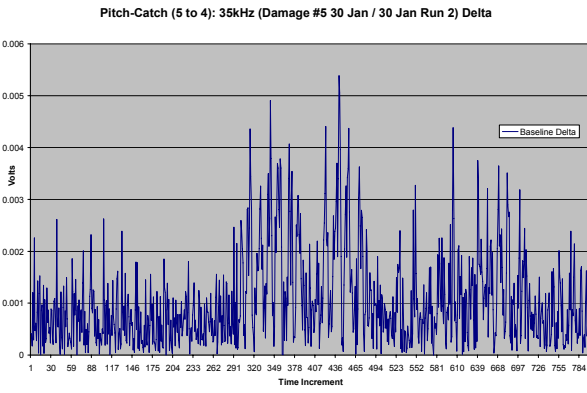
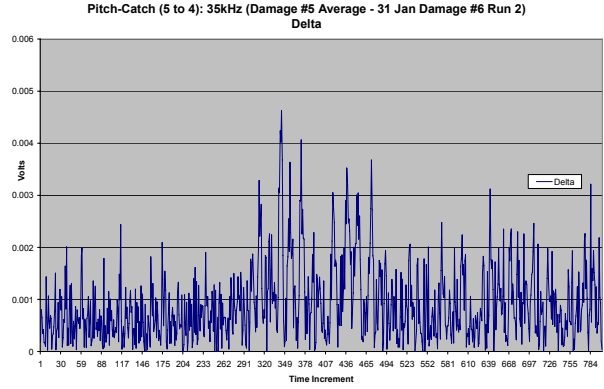
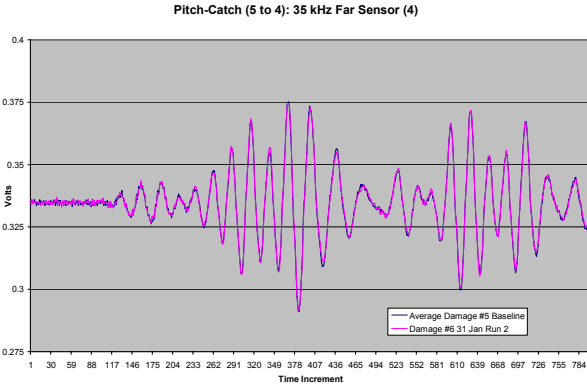

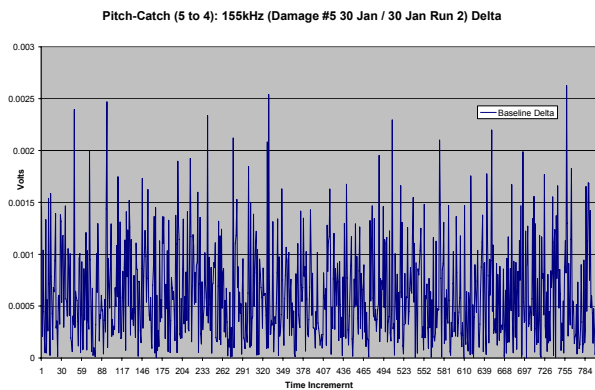
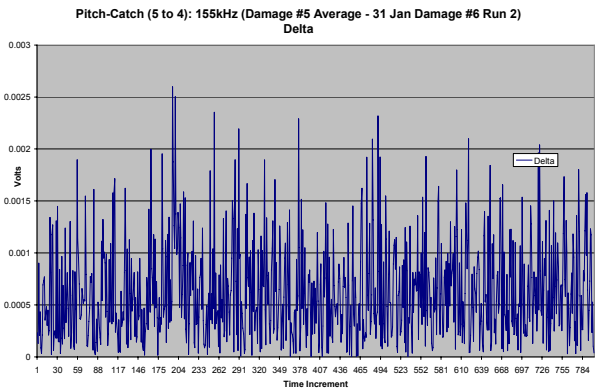
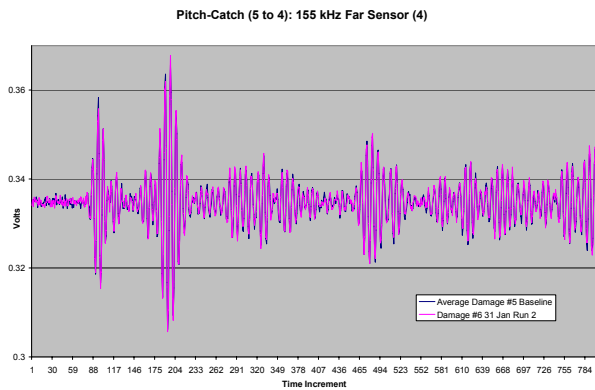
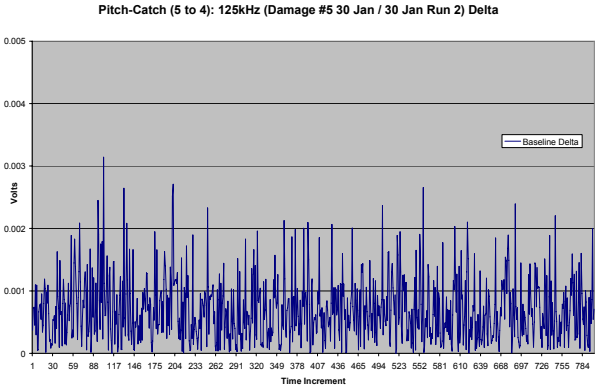
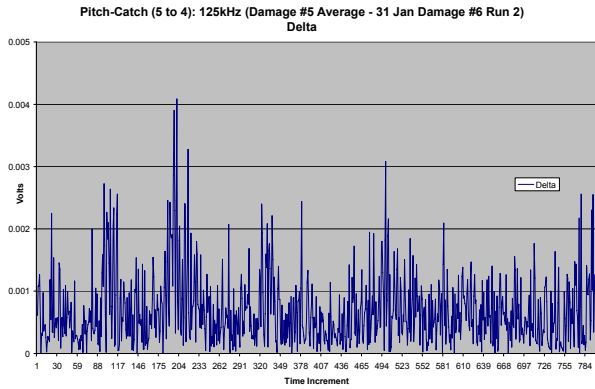
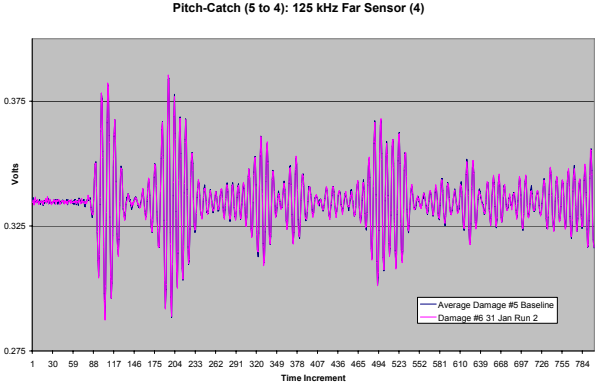
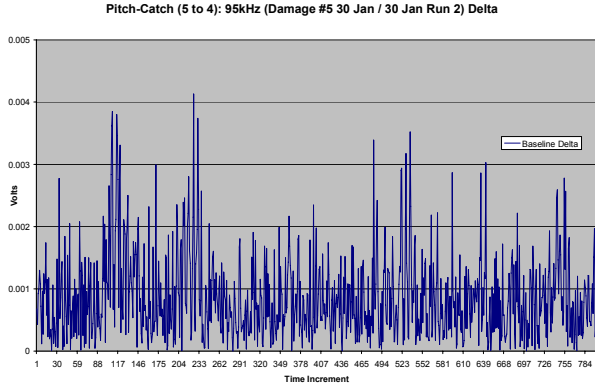

Pitch-Catch (Sensor 5 to 4): 01 Feb 07 , Damage 6 – 1/16” Hole, Centered Damage 5 Baseline

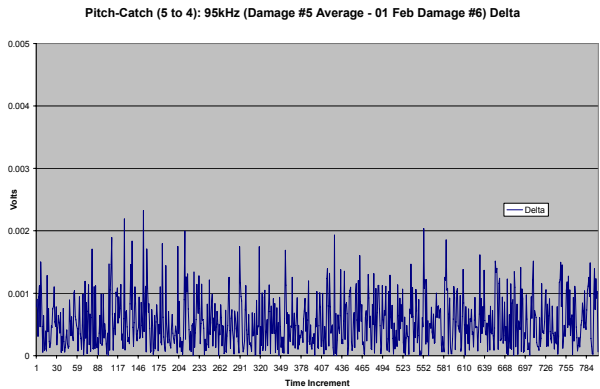
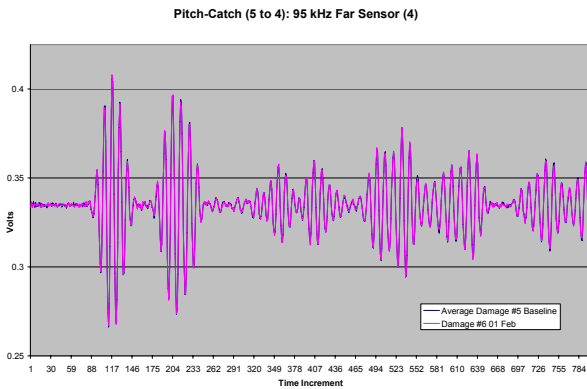
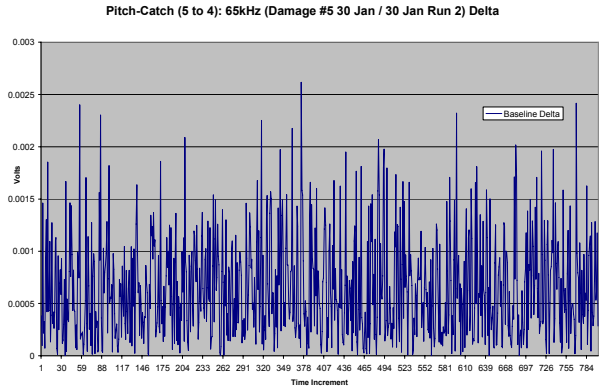
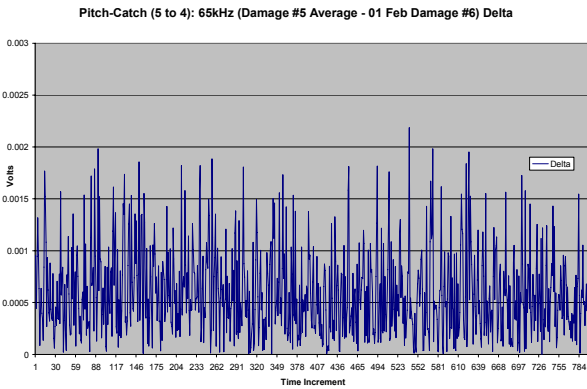
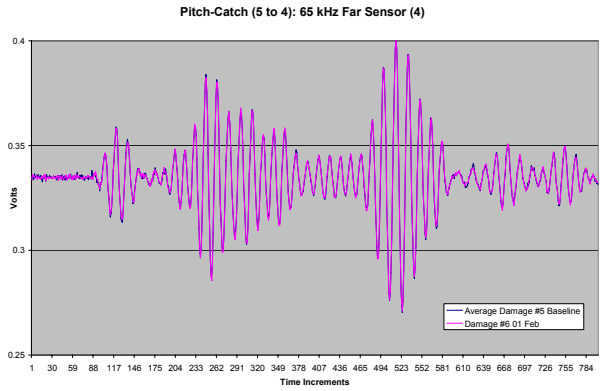
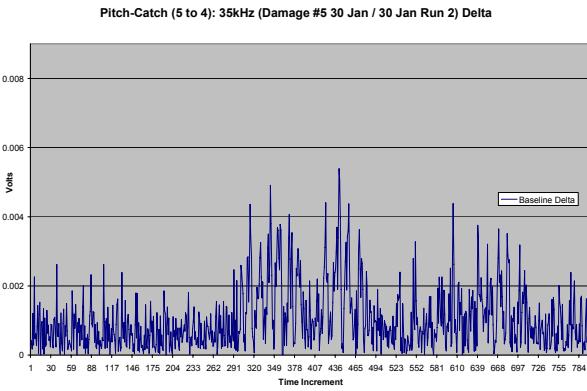
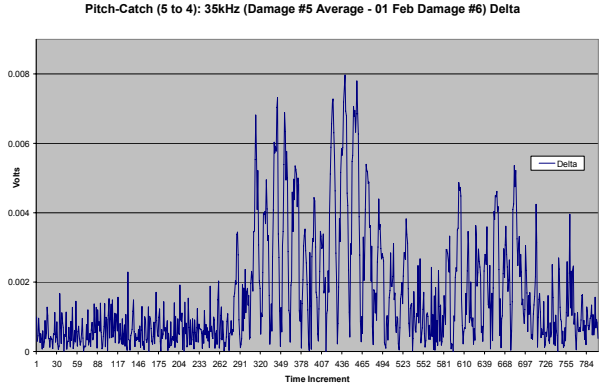
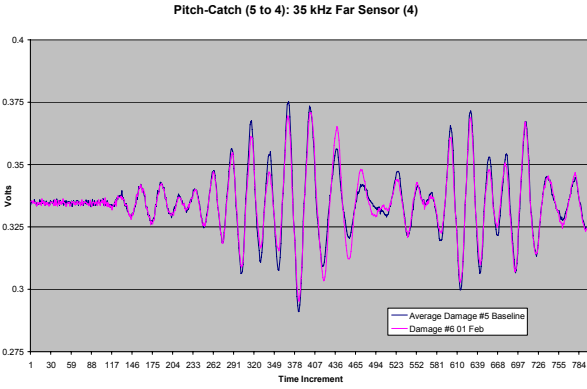

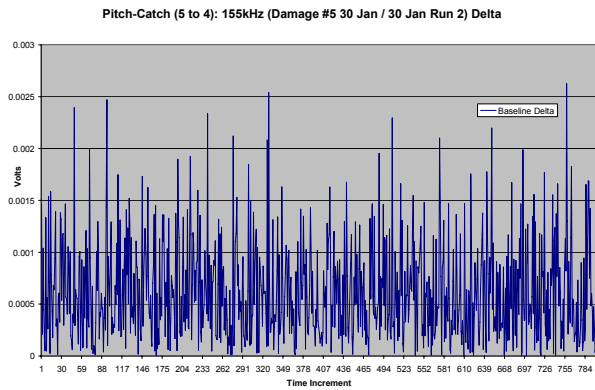
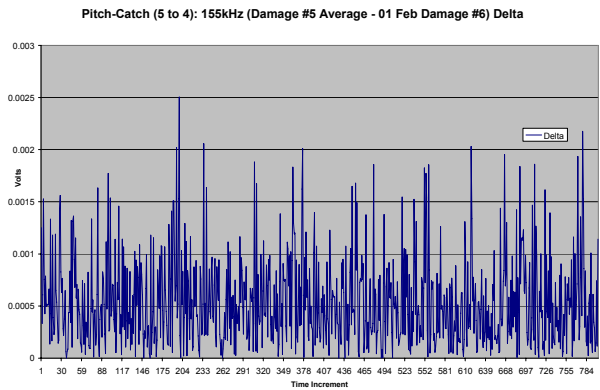
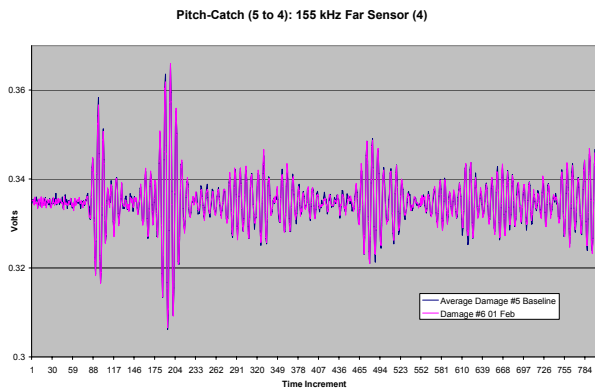
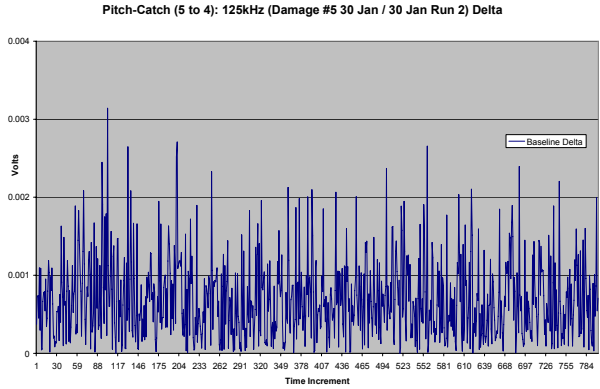
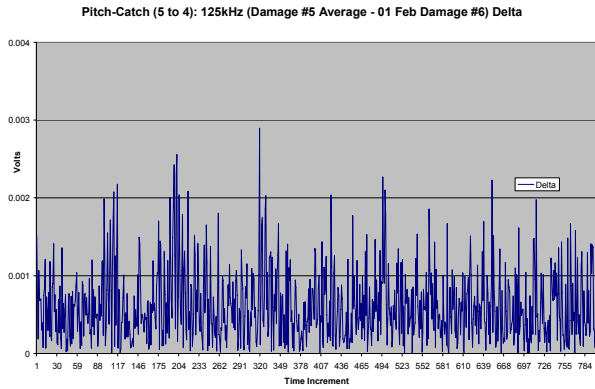
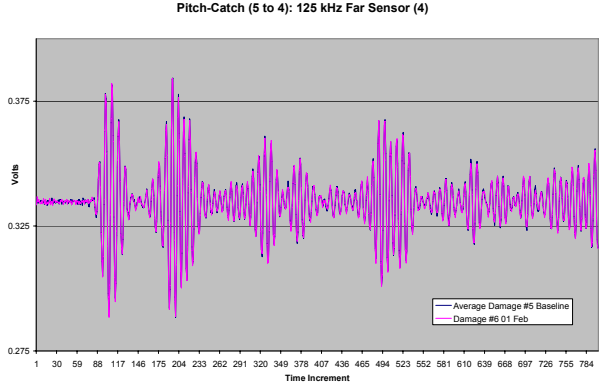
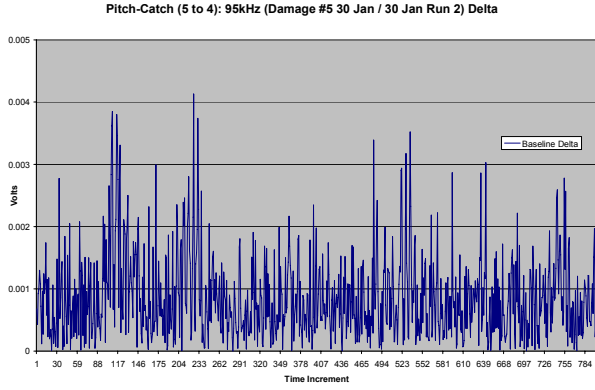

Pitch-Catch (Sensor 5 to 4): 01 Feb 07, Damage 7 – 1/4” Hole, Centered Damage 6 Baseline



Pitch-Catch (5 to 4): 35 kHz Far Sensor (4)

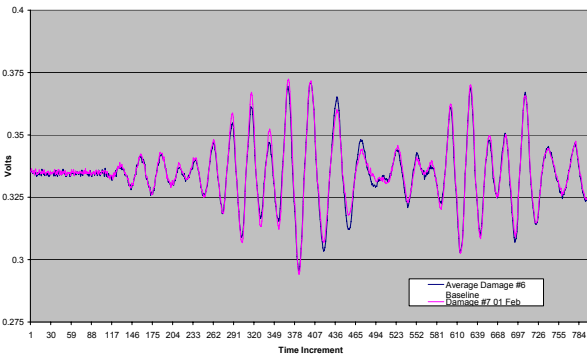

Pitch-Catch (5 to 4): 35kHz (Damage #6 Average - 01 Feb Damage #7) Delta

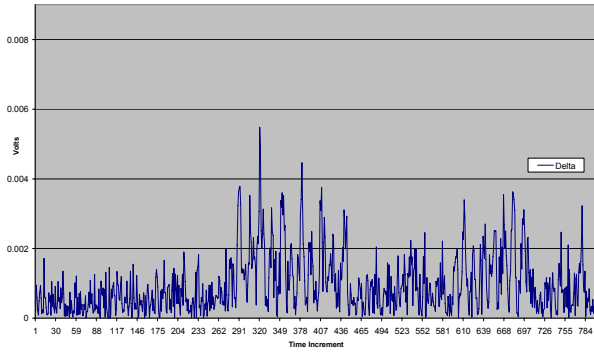

Pitch-Catch (5 to 4): 35kHz (Average Dmg #6 31 Jan / 31 Jan Run 2 / 01 Feb) Delta

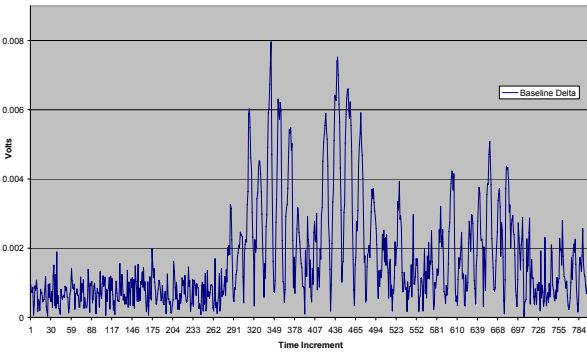

Pitch-Catch (5 to 4): 65 kHz Far Sensor (4)

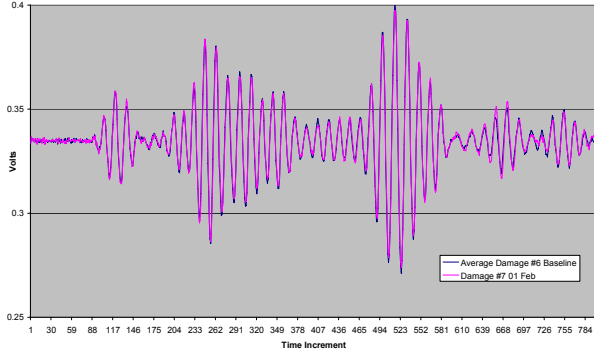

Pitch-Catch (5 to 4): 65kHz (Damage #6 Average - 01 Feb Damage #7) Delta

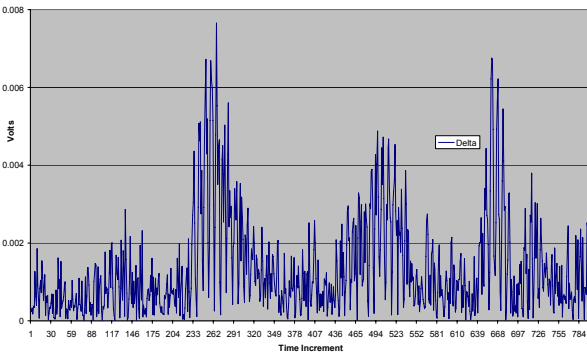

Pitch-Catch (5 to 4): 65kHz (Average Dmg #6 31 Jan / 31 Jan Run 2 / 01 Feb) Delta

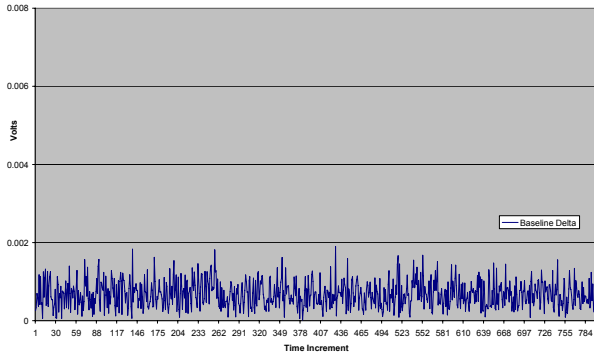

Pitch-Catch (5 to 4): 95 kHz Far Sensor (4)

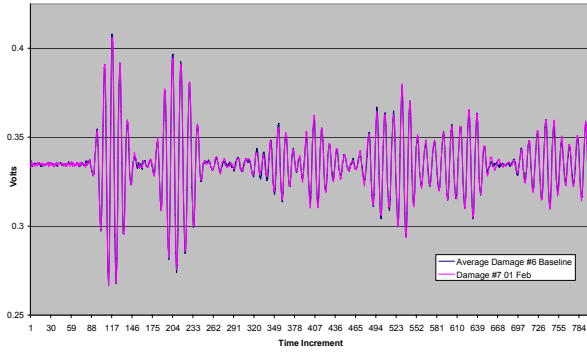

Pitch-Catch (5 to 4): 95kHz (Damage #6 Average - 01 Feb Damage #7) Delta

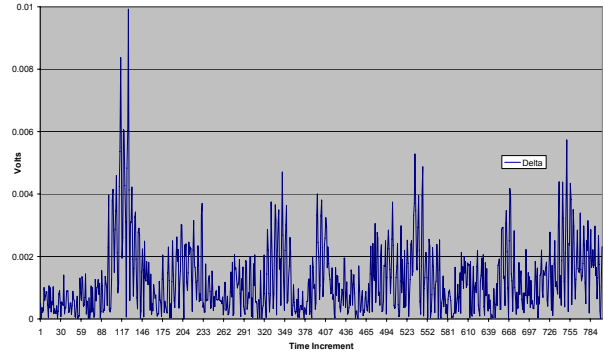

Pitch-Catch (5 to 4): 95kHz (Average Dmg #6 31 Jan / 31 Jan Run 2 / 01 Feb) Delta

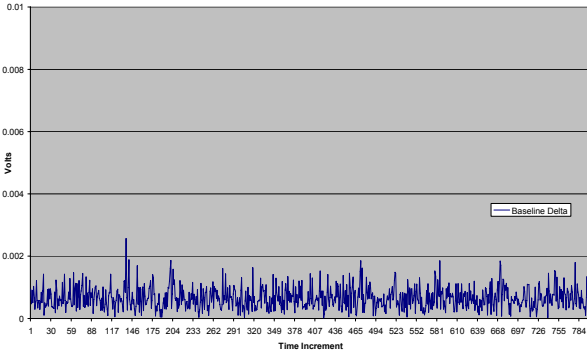

Pitch-Catch (5 to 4): 125 kHz Far Sensor (4)

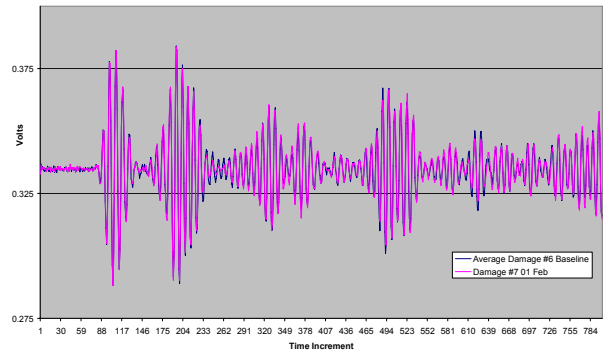

Pitch-Catch (5 to 4): 125kHz (Damage #6 Average - 01 Feb Damage #7) Delta

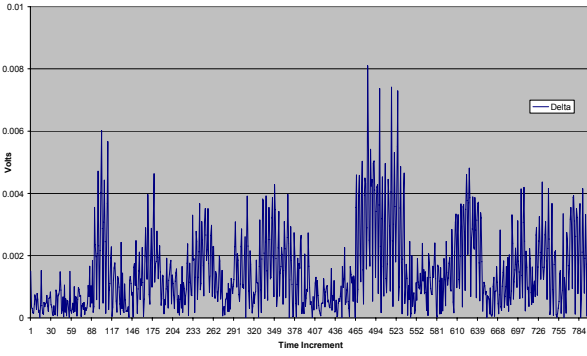

Pitch-Catch (5 to 4): 125kHz (Average Dmg #6 31 Jan / 31 Jan Run 2 / 01 Feb) Delta

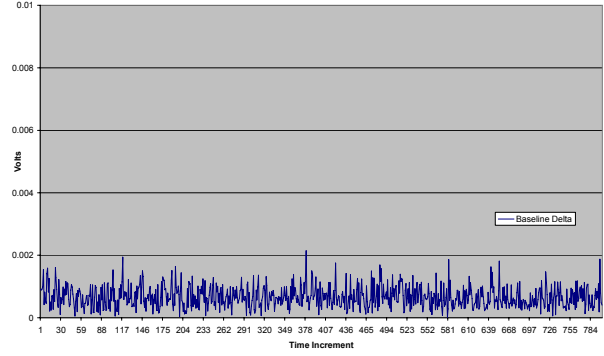

Pitch-Catch (5 to 4): 155 kHz Far Sensor (4)

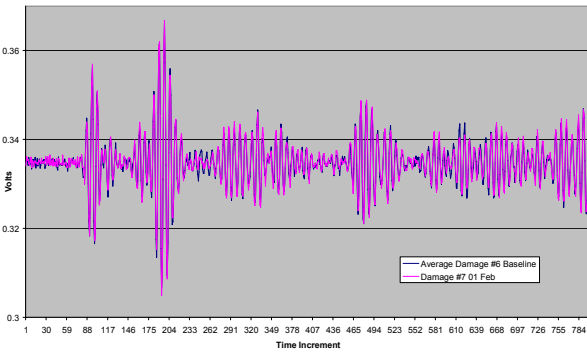

Pitch-Catch (5 to 4): 155kHz (Damage #6 Average - 01 Feb Damage #7) Delta

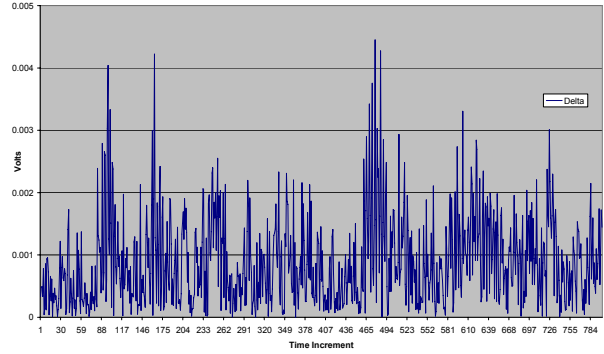

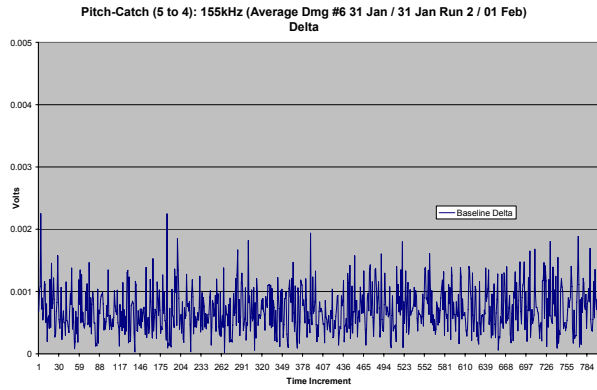

Pitch-Catch (Sensor 5 to 4): 01 Feb 07 Run 2, Damage 7 – 1/4” Hole, Centered
Damage 6 Baseline

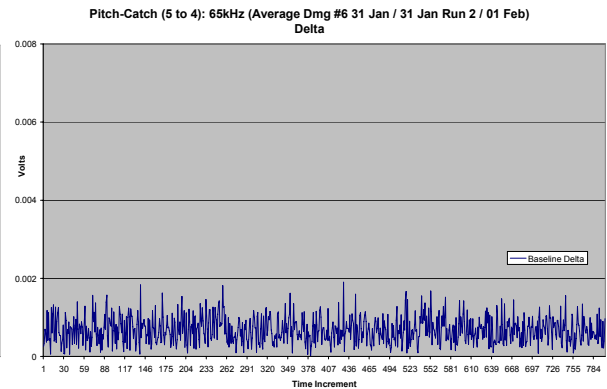
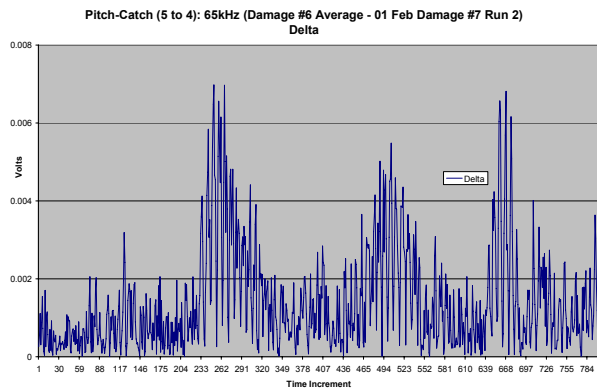
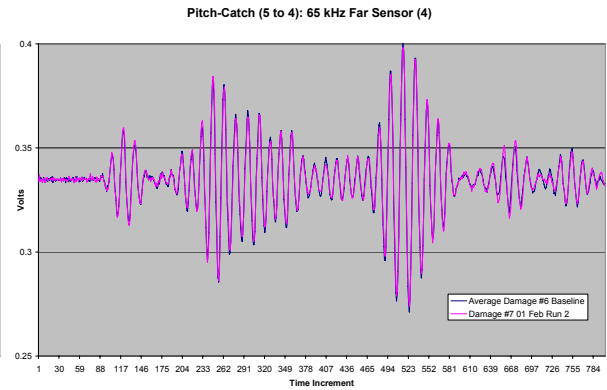
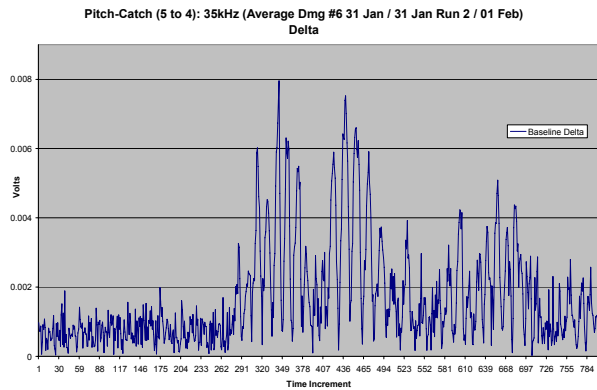
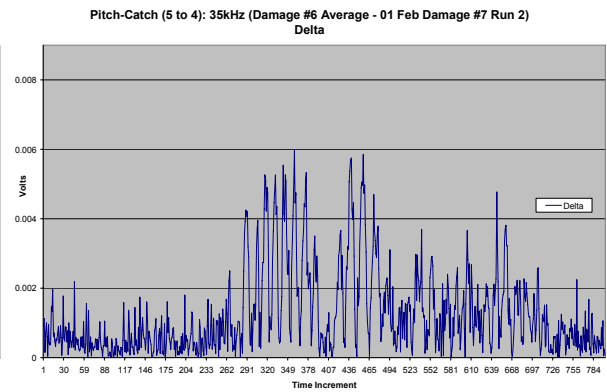
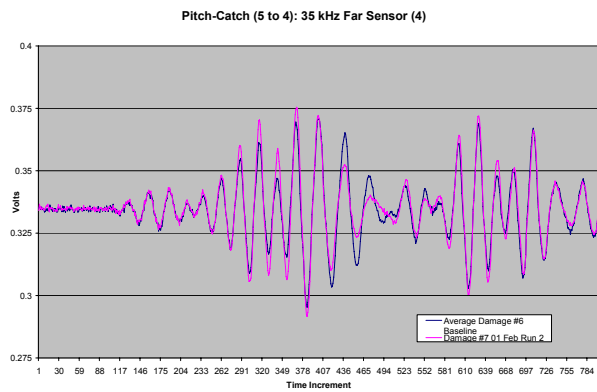

Pitch-Catch (5 to 4): 95 kHz Far Sensor (4)

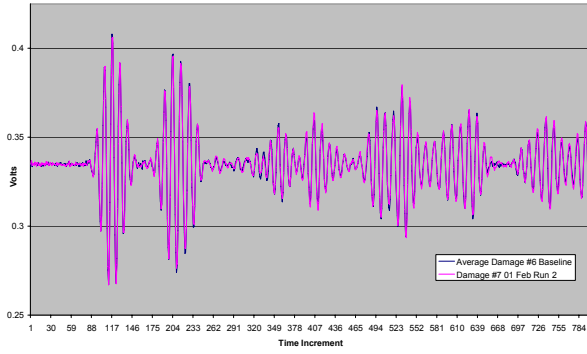

Pitch-Catch (5 to 4): 95kHz (Damage #6 Average - 01 Feb Damage #7 Run 2) Delta

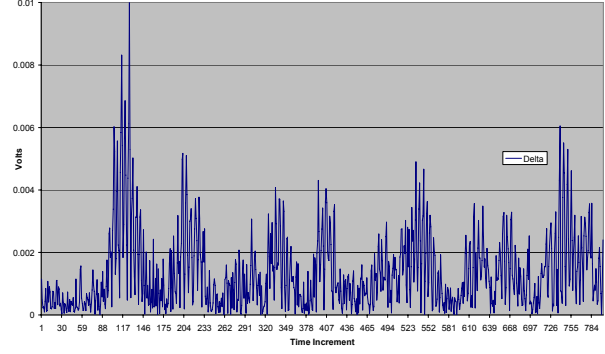

Pitch-Catch (5 to 4): 95kHz (Average Dmg #6 31 Jan / 31 Jan Run 2 / 01 Feb) Delta

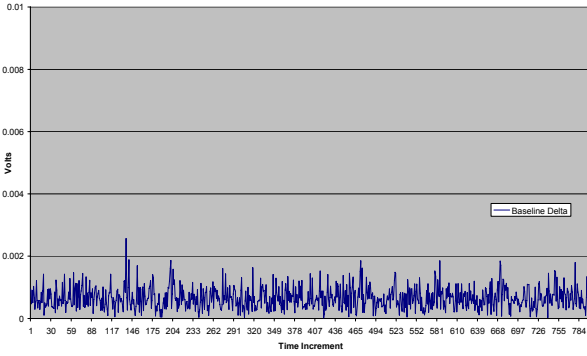

Pitch-Catch (5 to 4): 125 kHz Far Sensor (4)

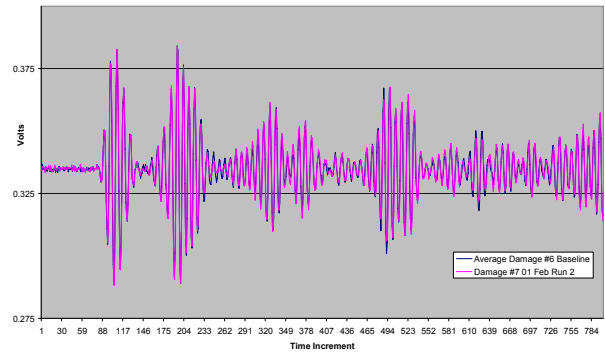

Pitch-Catch (5 to 4): 125kHz (Damage #6 Average - 01 Feb Damage #7 Run 2) Delta

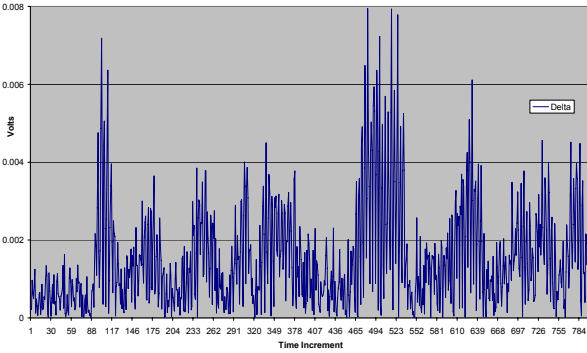

Pitch-Catch (5 to 4): 125kHz (Average Dmg #6 31 Jan / 31 Jan Run 2 / 01 Feb) Delta

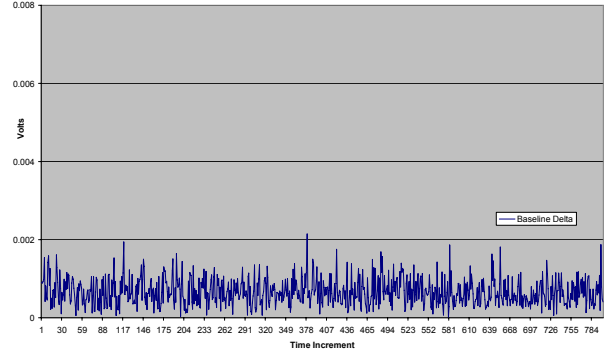

Pitch-Catch (5 to 4): 155 kHz Far Sensor (4)

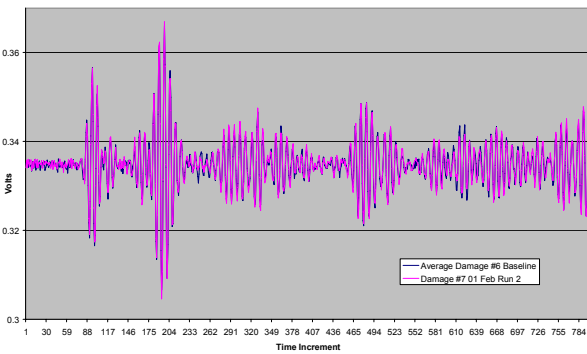

Pitch-Catch (5 to 4): 155kHz (Damage #6 Average - 01 Feb Damage #7 Run 2) Delta

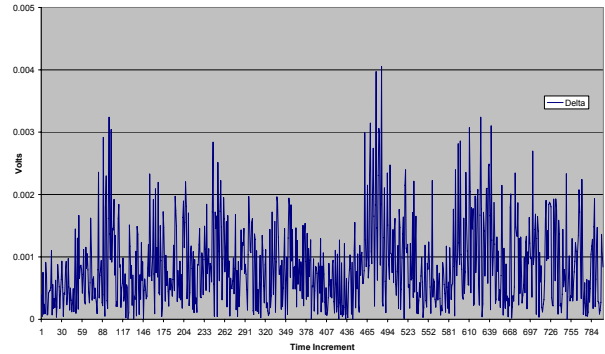

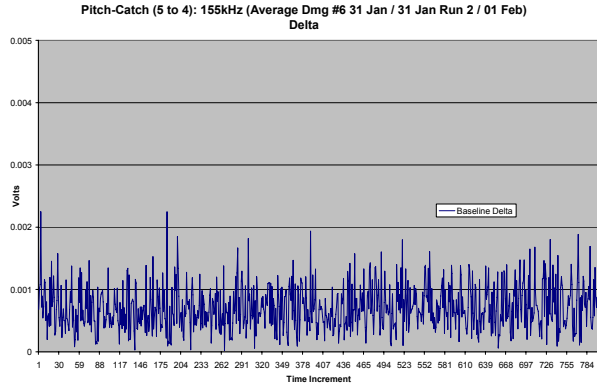

Pitch-Catch (Sensor 5 to 4): 02 Feb 07, Damage 7 – 1/4” Hole, Centered
Damage 6 Baseline

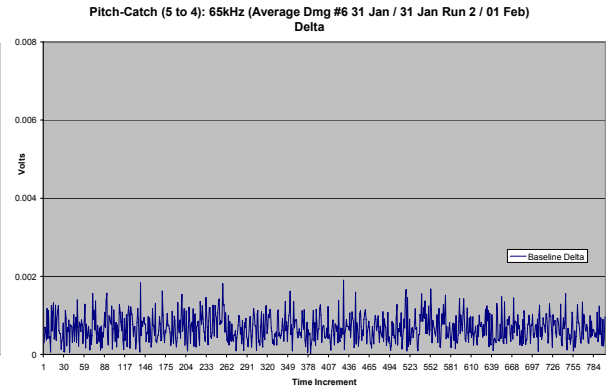
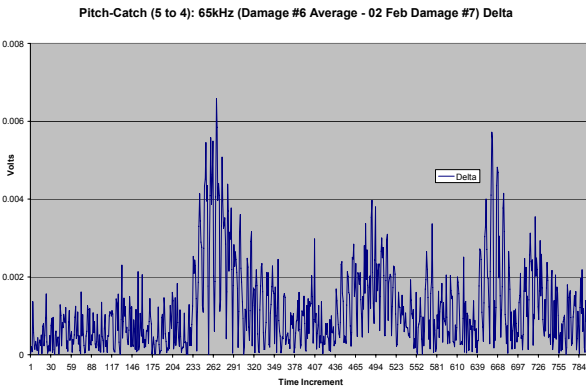
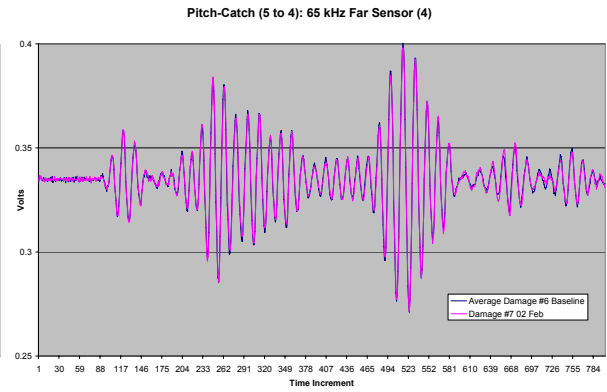
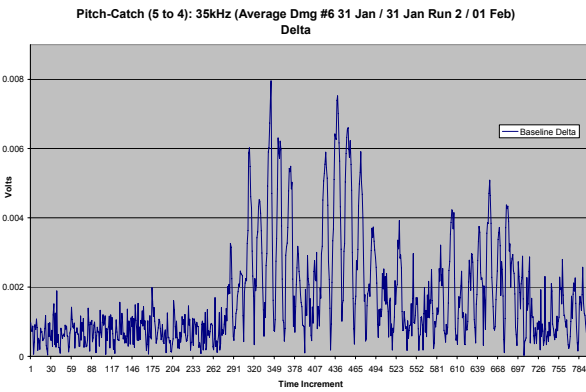
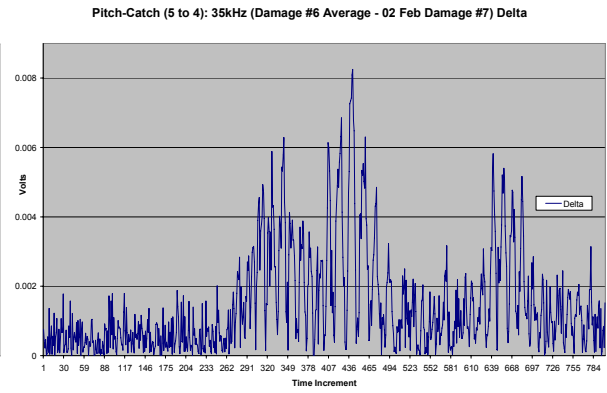
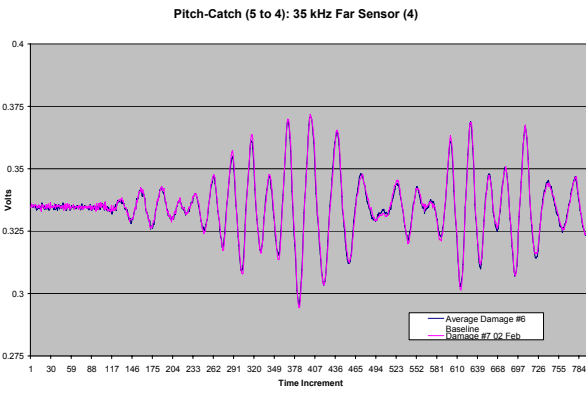

Pitch-Catch (5 to 4): 95 kHz Far Sensor (4)

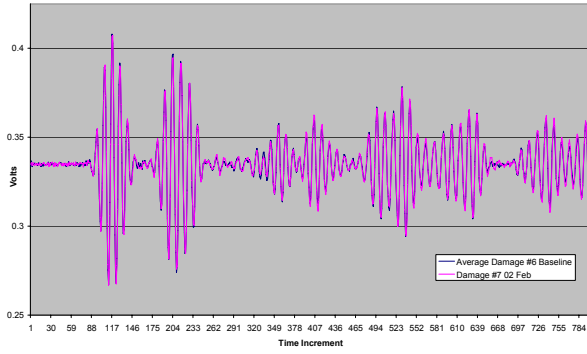

Pitch-Catch (5 to 4): 95kHz (Damage #6 Average - 02 Feb Damage #7) Delta

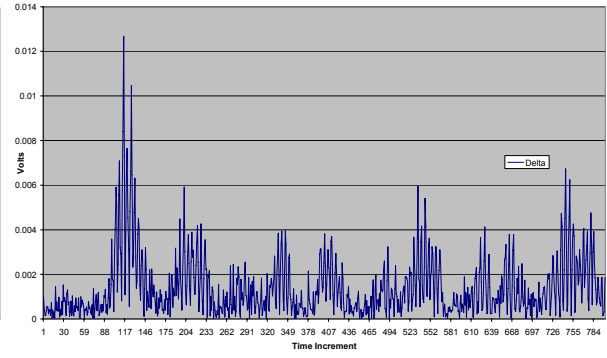

Pitch-Catch (5 to 4): 95kHz (Average Dmg #6 31 Jan / 31 Jan Run 2 / 01 Feb) Delta

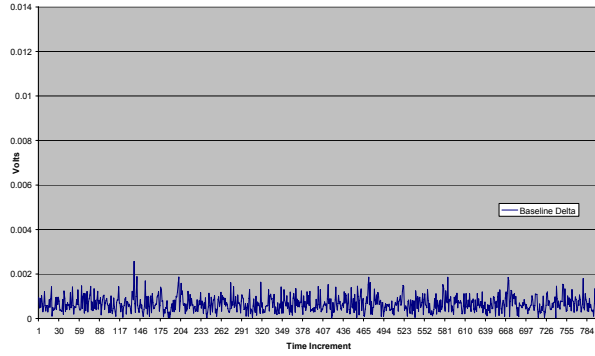

Pitch-Catch (5 to 4): 125 kHz Far Sensor (4)

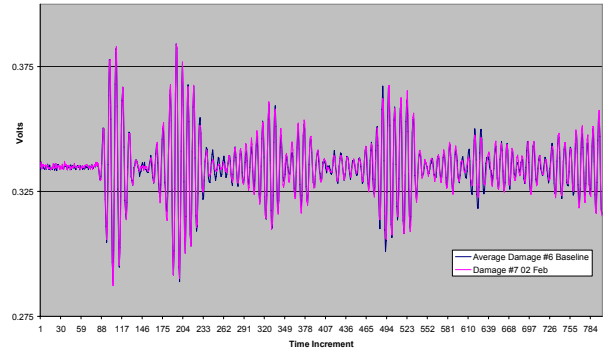

Pitch-Catch (5 to 4): 125kHz (Damage #6 Average - 02 Feb Damage #7) Delta

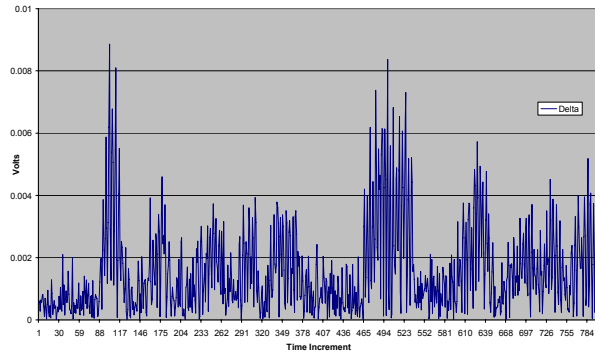

Pitch-Catch (5 to 4): 125kHz (Average Dmg #6 31 Jan / 31 Jan Run 2 / 01 Feb) Delta

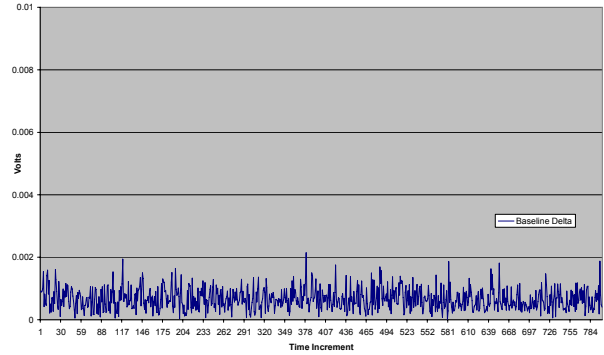

Pitch-Catch (5 to 4): 155 kHz Far Sensor (4)

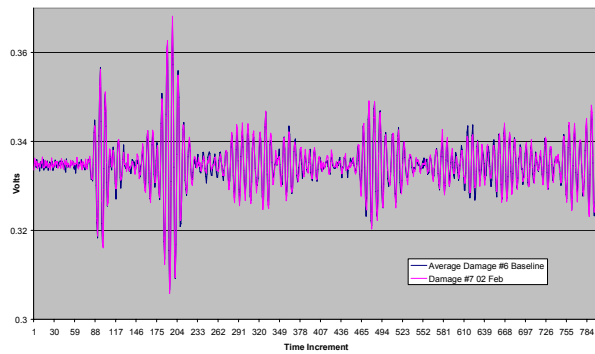

Pitch-Catch (5 to 4): 155kHz (Damage #6 Average - 02 Feb Damage #7) Delta

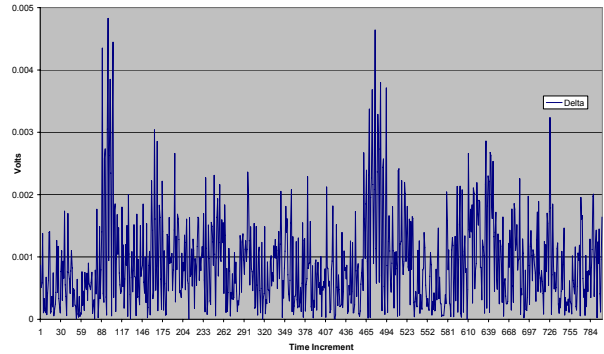

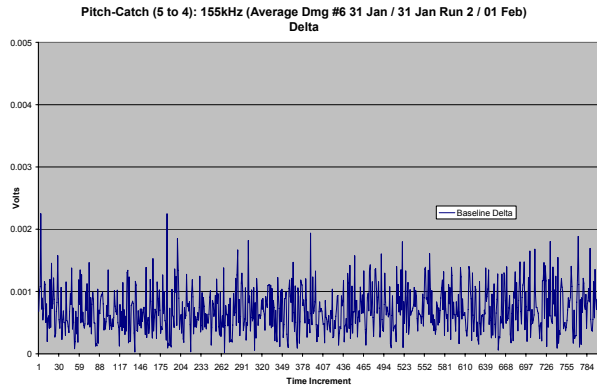

Pitch-Catch (Sensor 5 to 4): 02 Feb 07, Damage 8 – 5mm Gouge, Centered, 100mm Offset
Damage 7 Baseline



Pitch-Catch (5 to 4): 35 kHz Far Sensor (4)

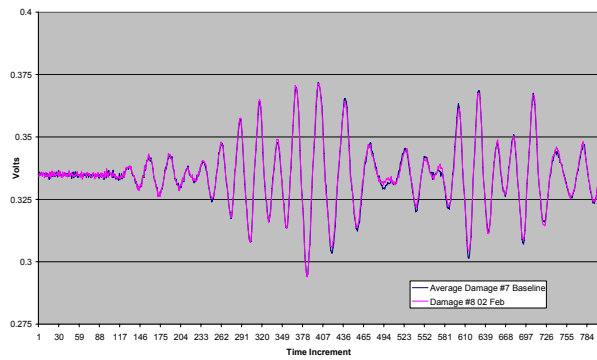

Pitch-Catch (5 to 4): 35kHz (Damage #7 Average - 02 Feb Damage #8) Delta

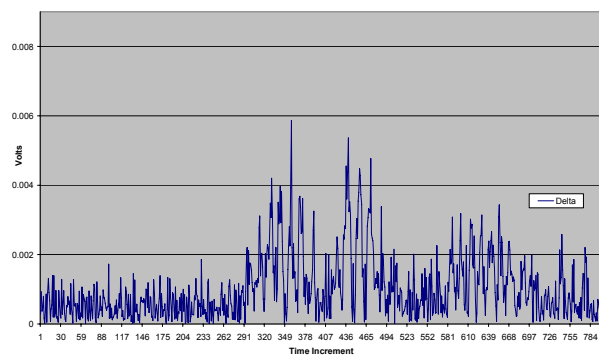

Pitch-Catch (5 to 4): 35kHz (Average Dmg #7 01 Feb / 01 Feb Run 2 / 02 Feb)
Delta

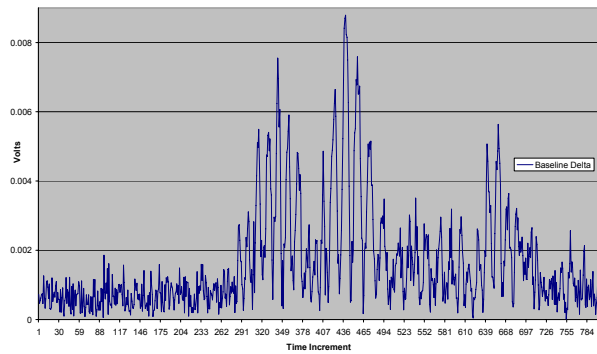

Pitch-Catch (5 to 4): 65 kHz Far Sensor (4)

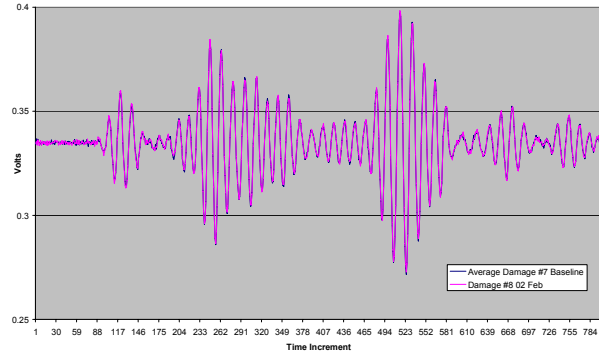

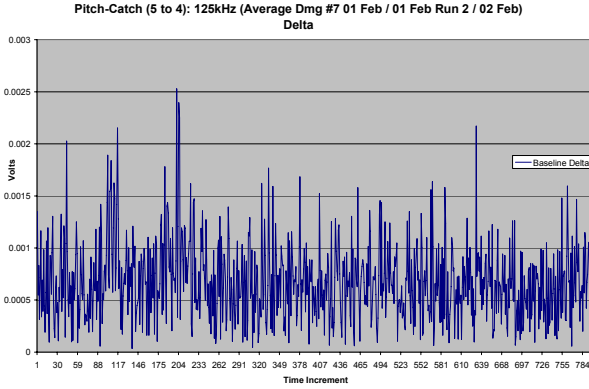
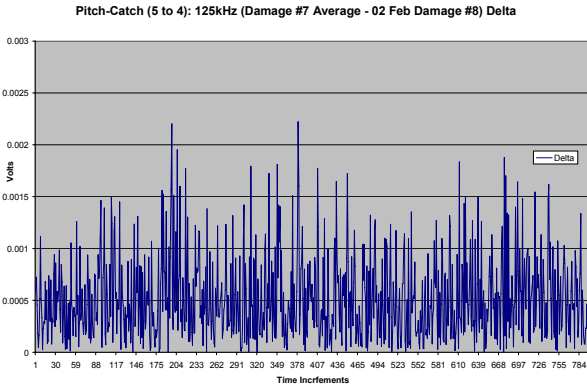
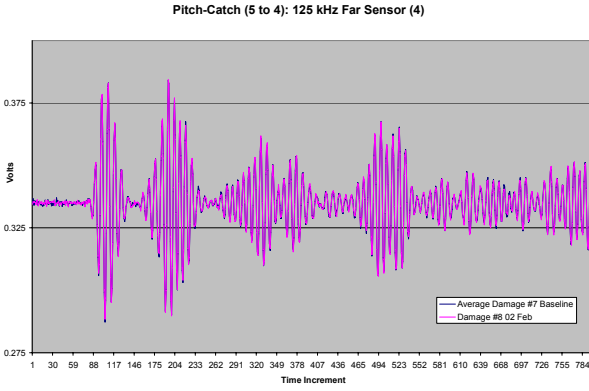
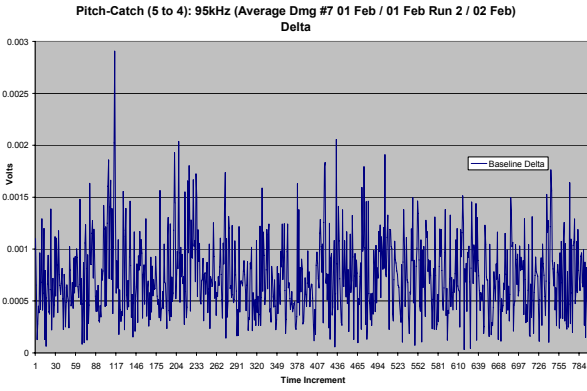
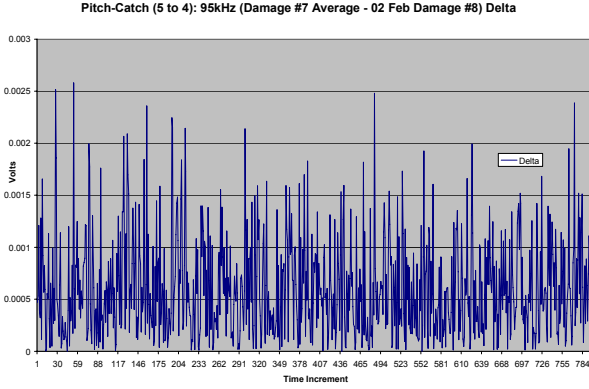
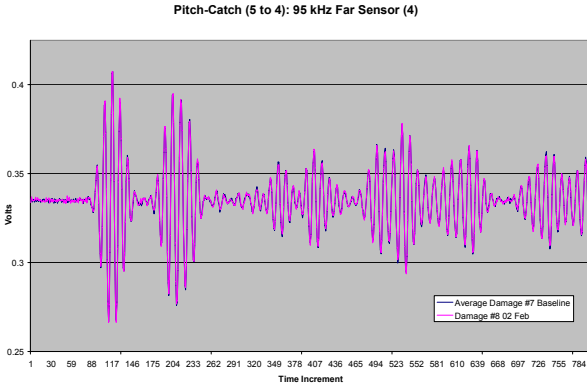
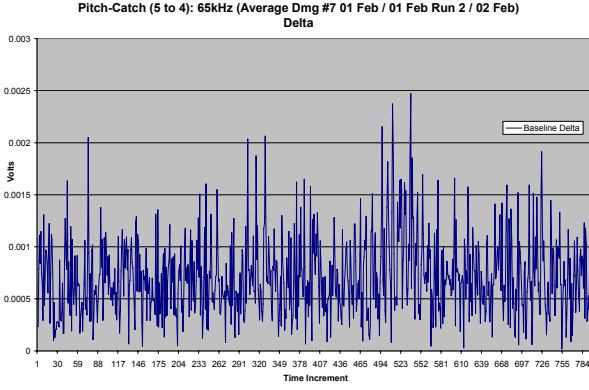
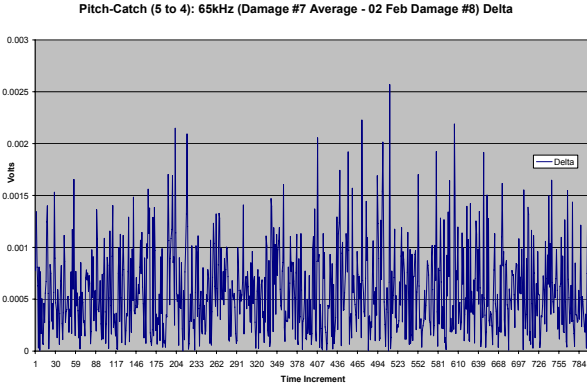

Pitch-Catch (5 to 4): 155 kHz Far Sensor (4)

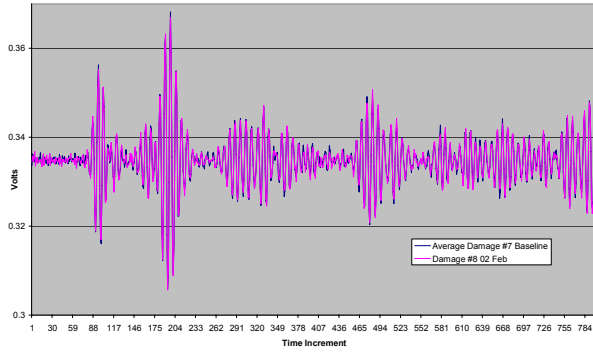

Pitch-Catch (5 to 4): 155kHz (Damage #7 Average - 02 Feb Damage #8) Delta

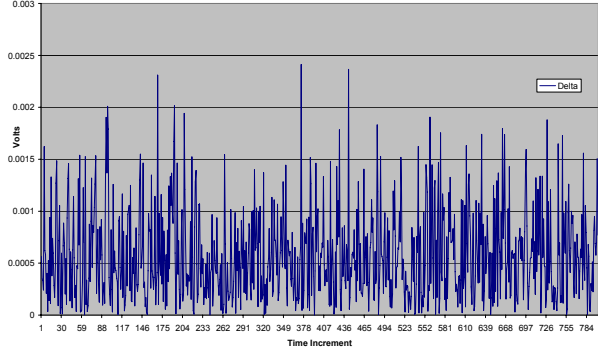

Pitch-Catch (5 to 4): 155kHz (Average Dmg #7 01 Feb / 01 Feb Run 2 / 02 Feb) Delta

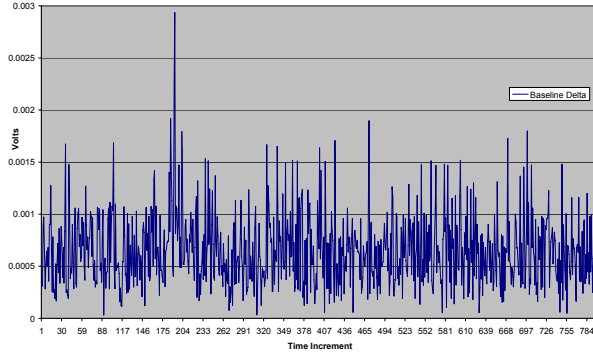

Pitch-Catch (Sensor 5 to 4): 02 Feb 07 Run 2, Damage 8 – 5mm Gouge, Centered, 100mm Offset, Damage 7 Baseline

Pitch-Catch (5 to 4): 35 kHz Far Sensor (4)

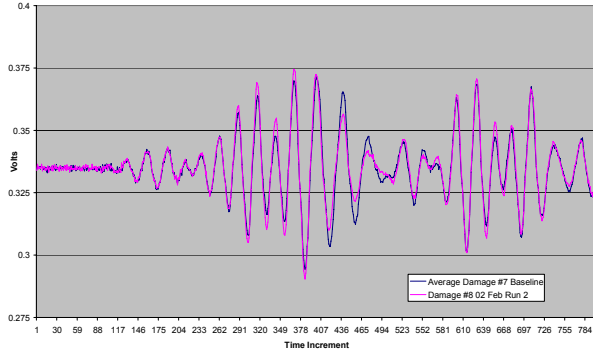

Pitch-Catch (5 to 4): 35kHz (Damage #7 Average - 02 Feb Damage #8 Run 2) Delta

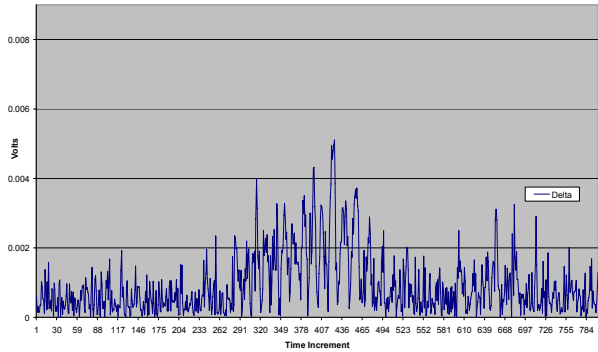

Pitch-Catch (5 to 4): 35kHz (Average Dmg #7 01 Feb / 01 Feb Run 2 / 02 Feb) Delta

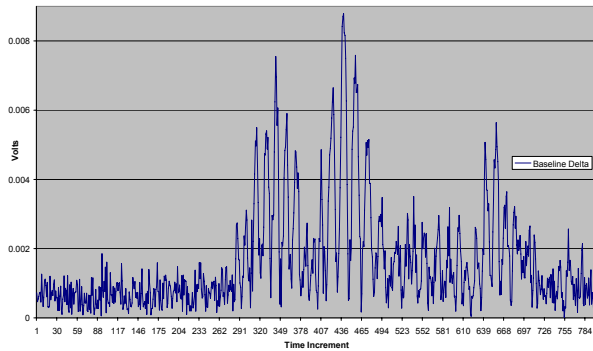

Pitch-Catch (5 to 4): 65 kHz Far Sensor (4)

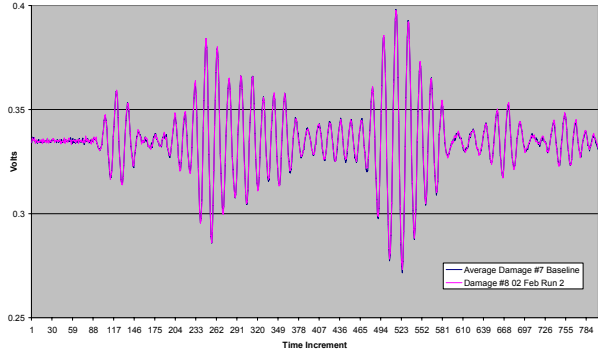

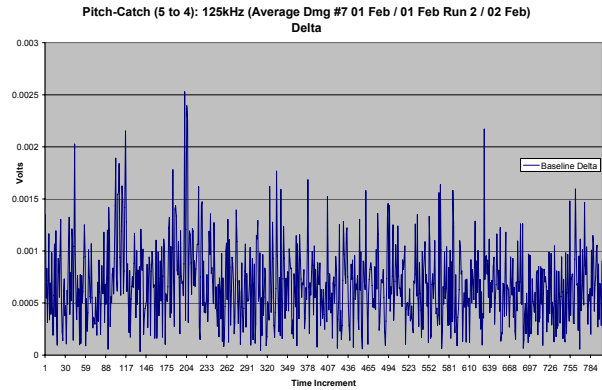
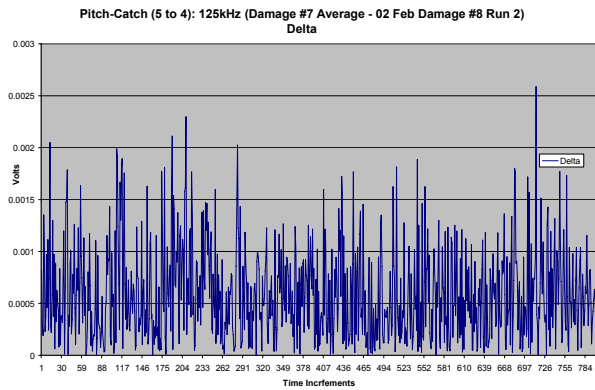
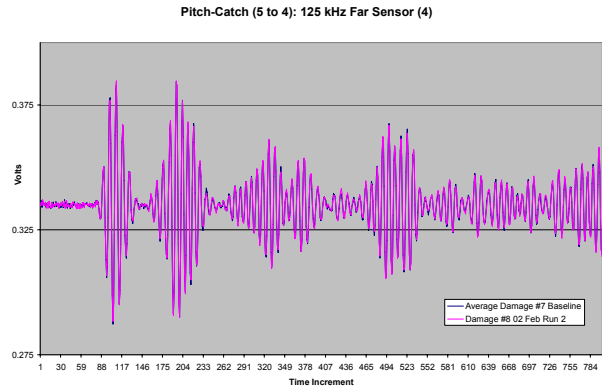
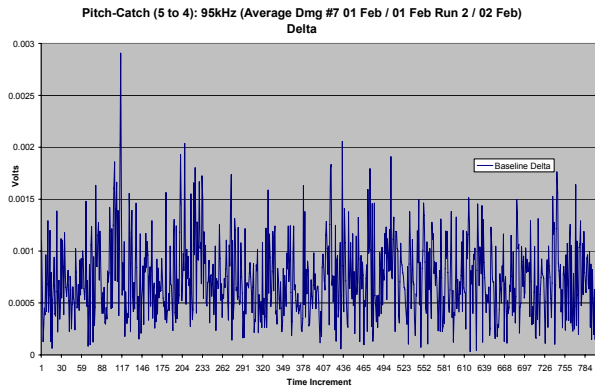
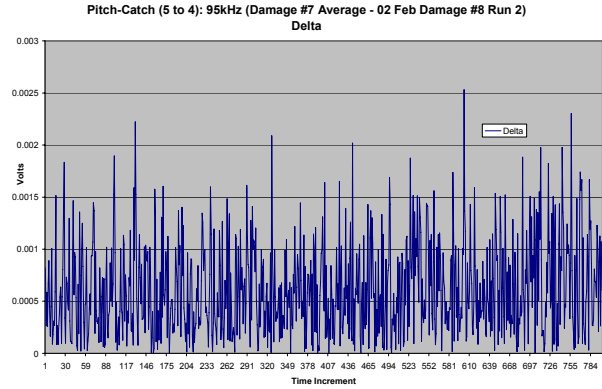
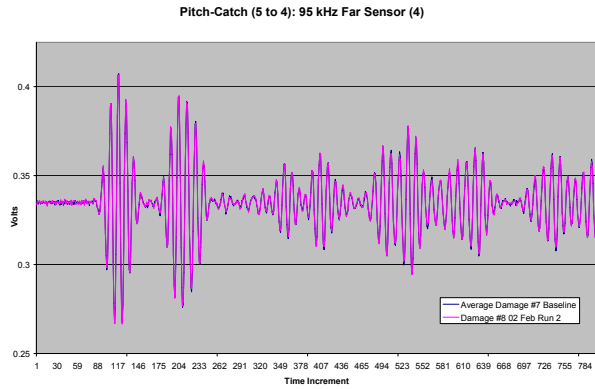
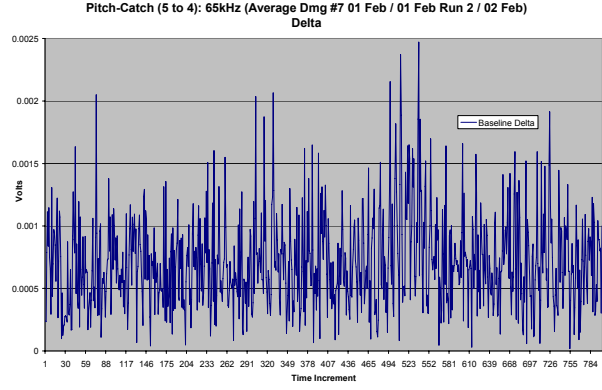
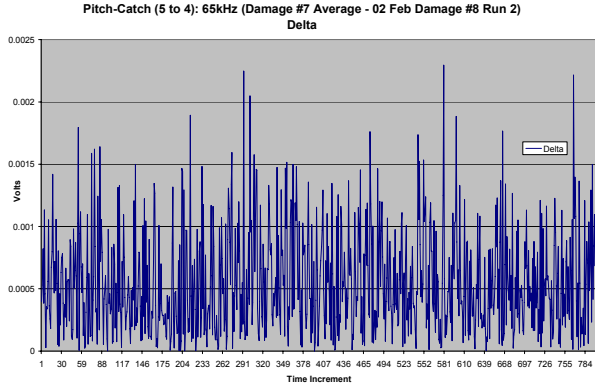

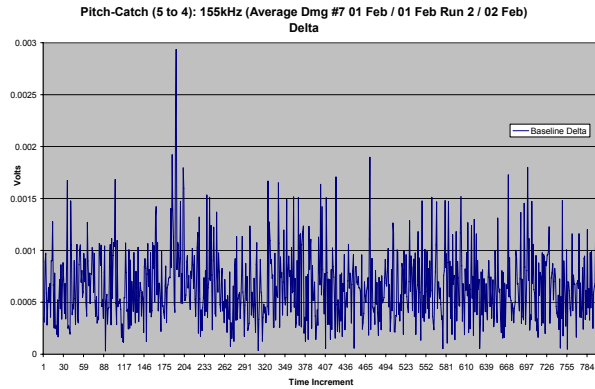
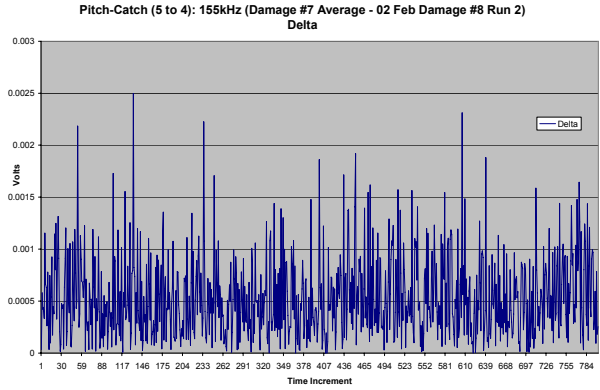
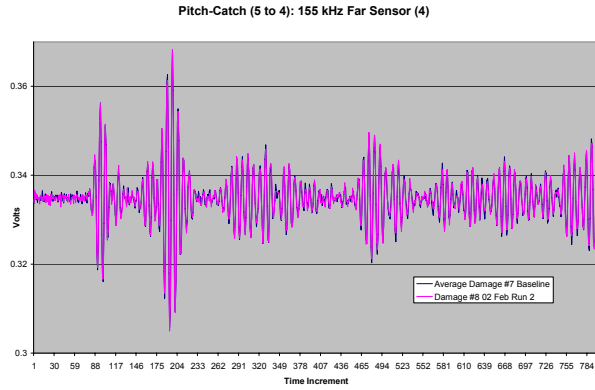

Pitch-Catch (Sensor 5 to 4): 03 Feb 07, Damage 8 – 5mm Gouge, Centered, 100mm Offset, Damage 7 Baseline

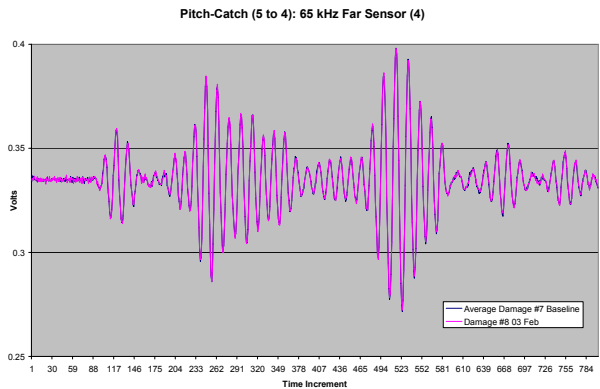
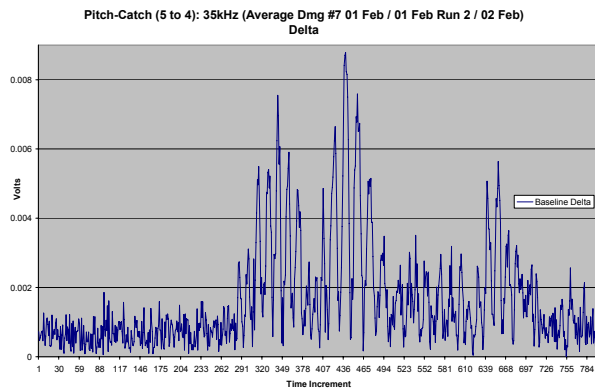
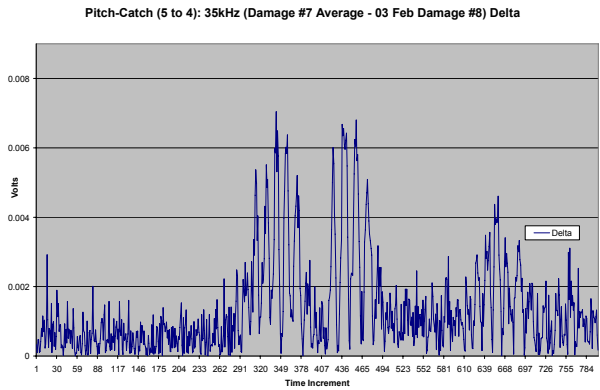
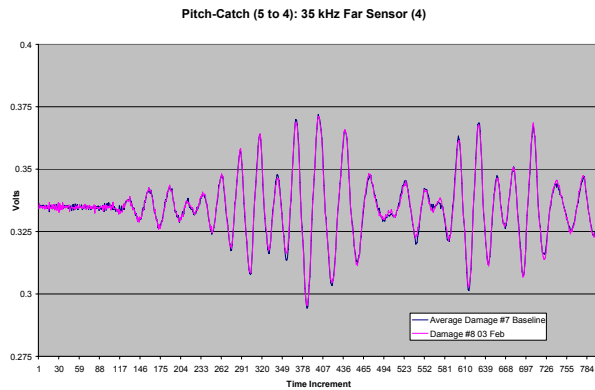

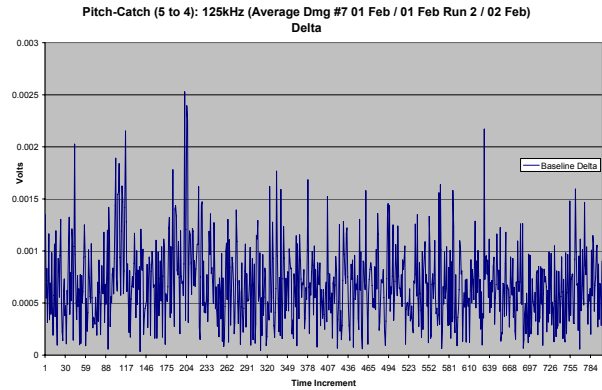
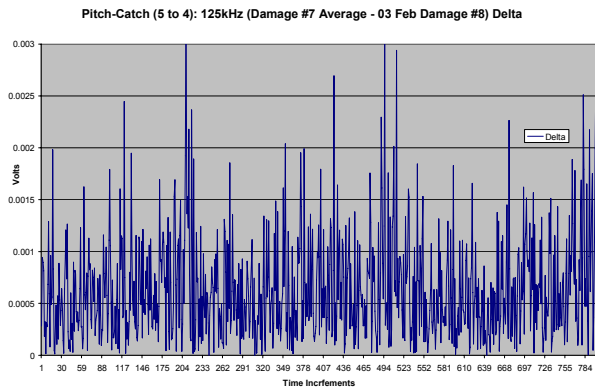
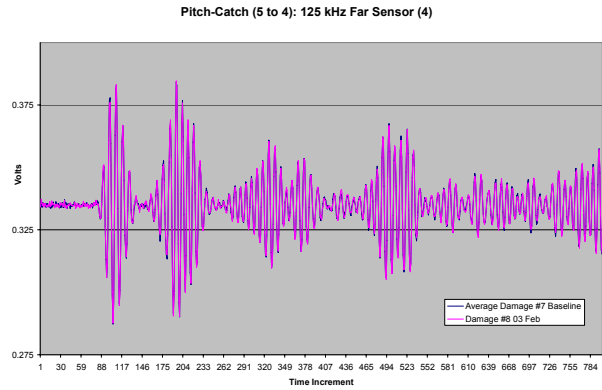
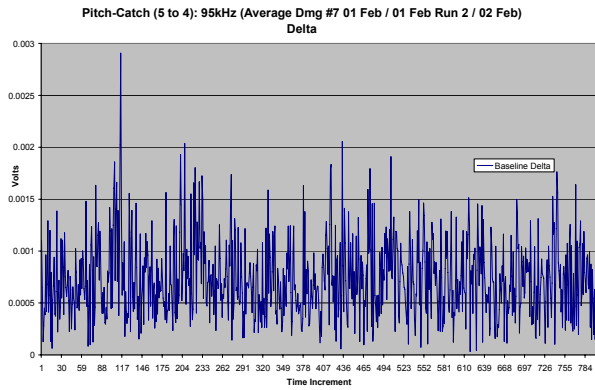
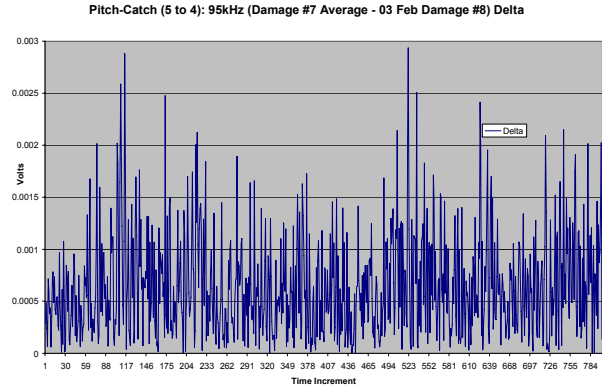
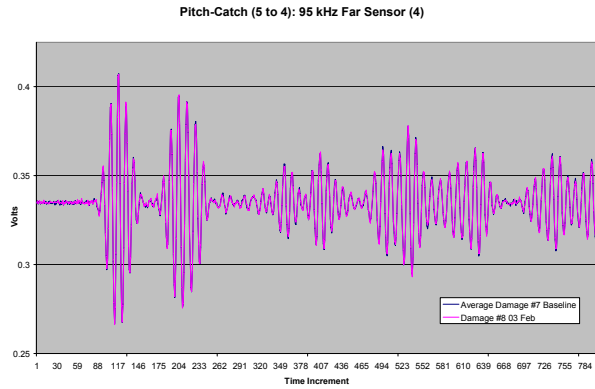
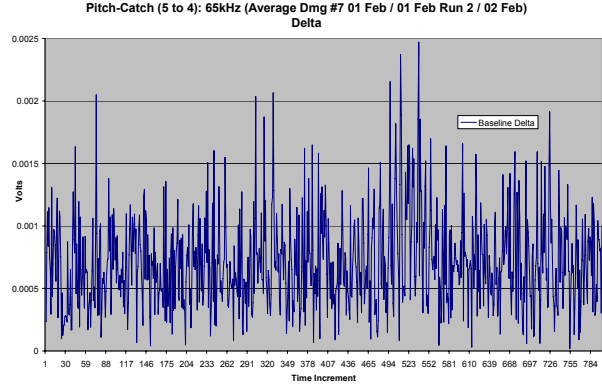
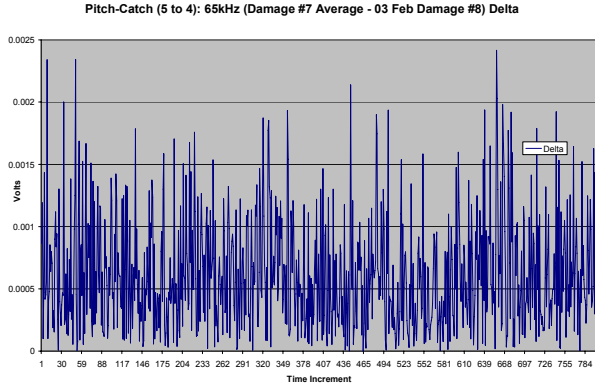

Pitch-Catch (5 to 4): 155 kHz Far Sensor (4)

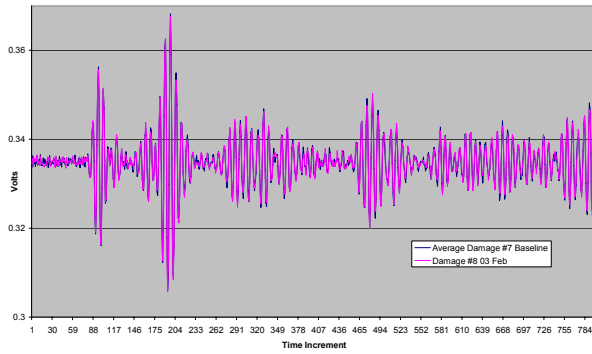

Pitch-Catch (5 to 4): 155kHz (Damage #7 Average - 03 Feb Damage #8) Delta

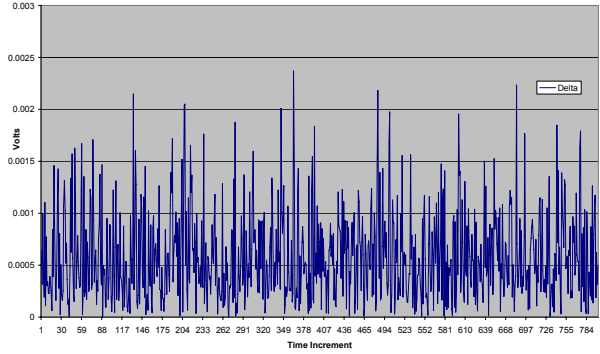

Pitch-Catch (5 to 4): 155kHz (Average Dmg #7 01 Feb / 01 Feb Run 2 / 02 Feb) Delta

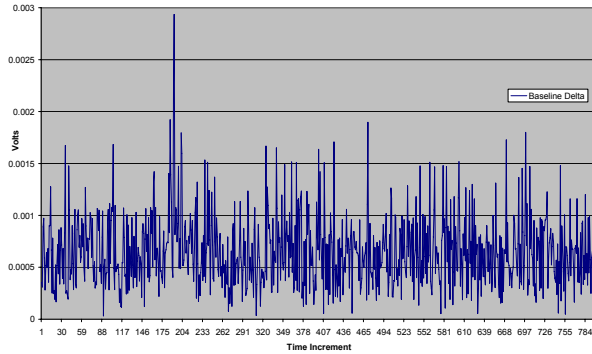

Pitch-Catch (Sensor 5 to 4): 03 Feb 07, Damage 9 – 1/16” Hole, Centered, 100mm Offset
Damage 8 Baseline

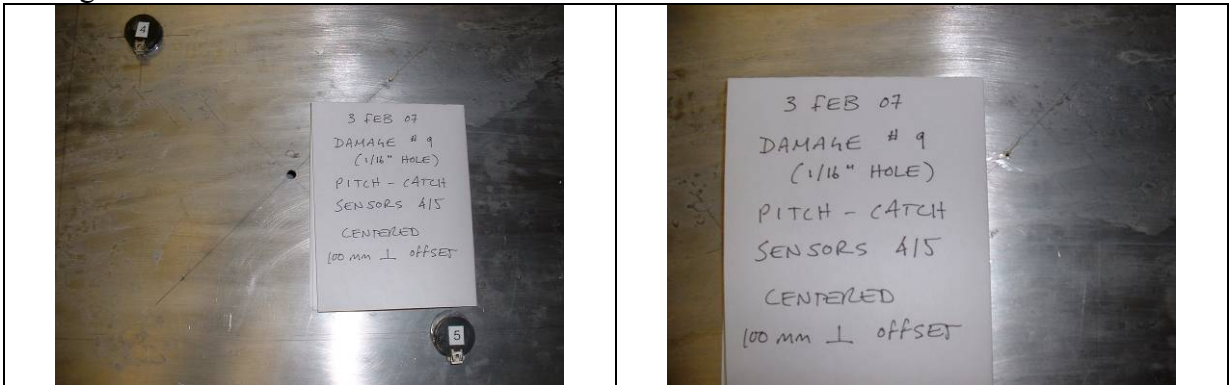

Pitch-Catch (5 to 4): 35 kHz Far Sensor (4)

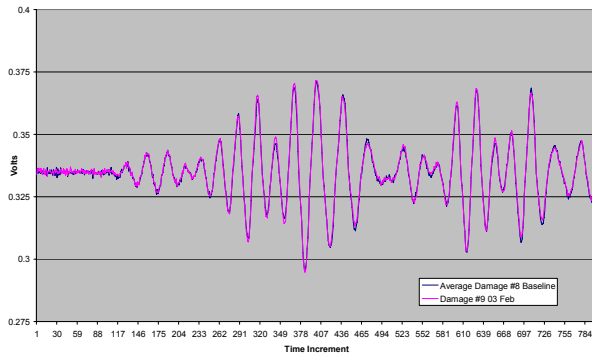

Pitch-Catch (5 to 4): 35kHz (Damage #8 Average - 03 Feb Damage #9) Delta

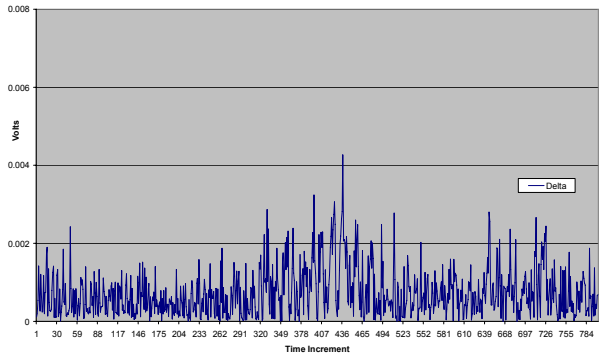

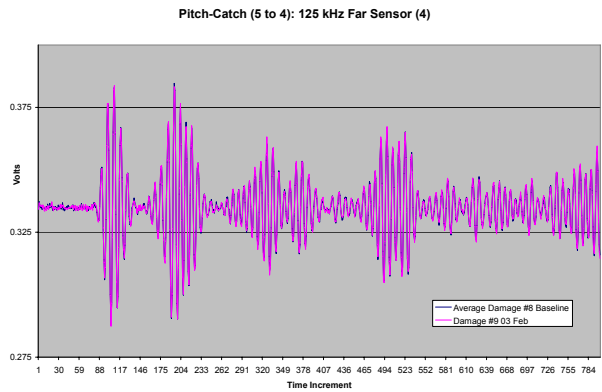
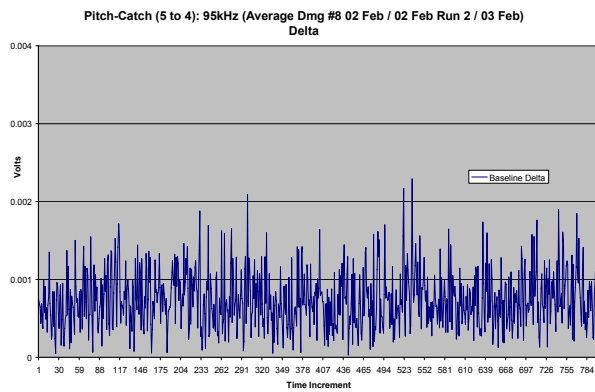
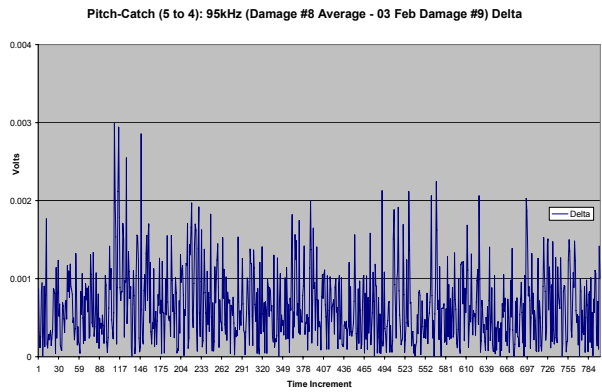
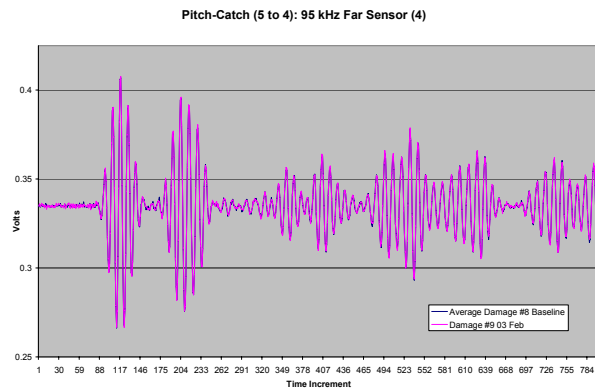
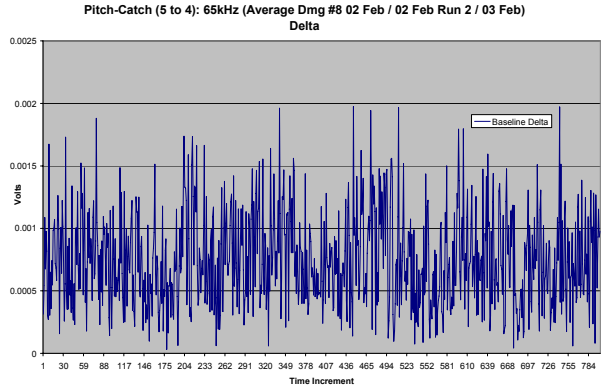
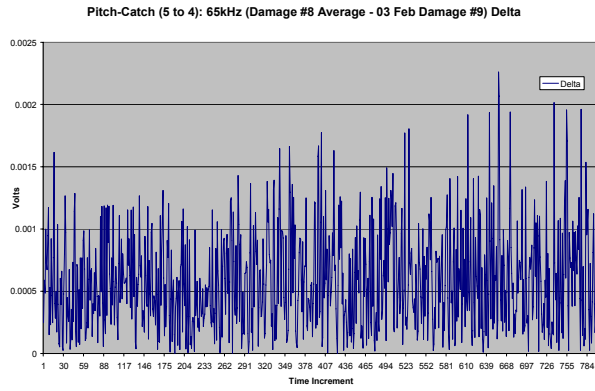
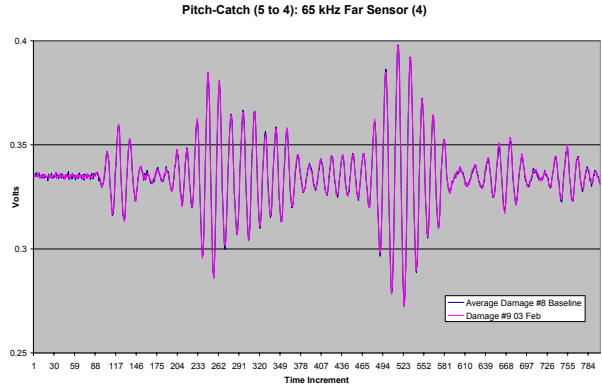
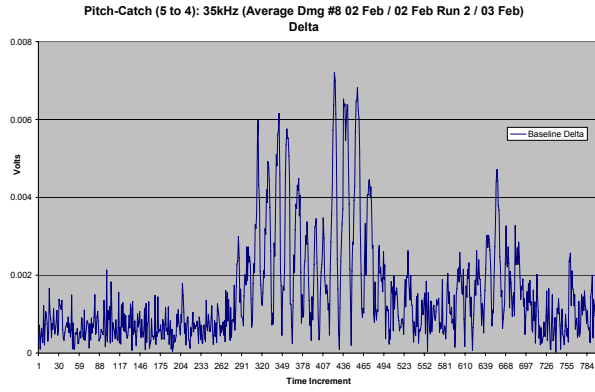

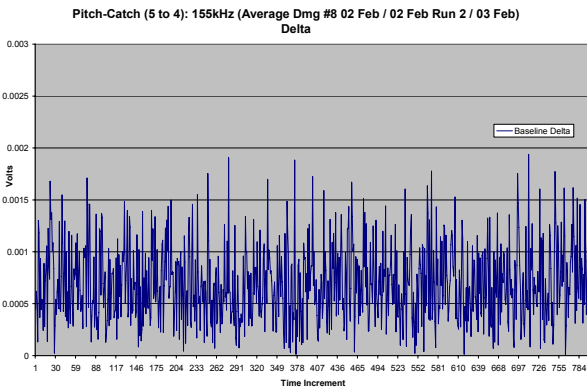
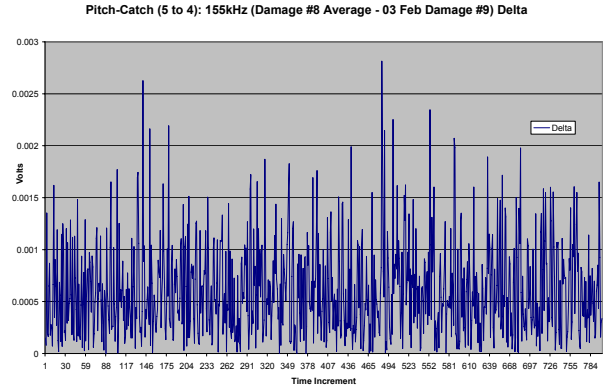
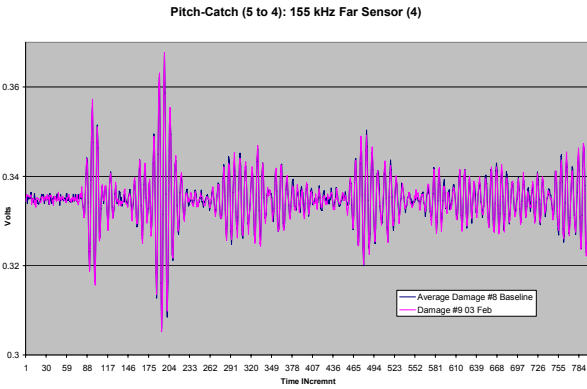
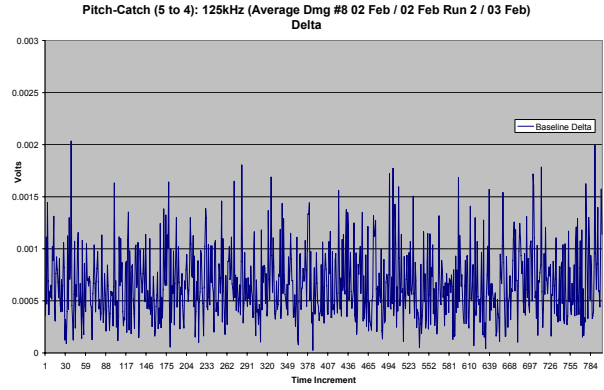
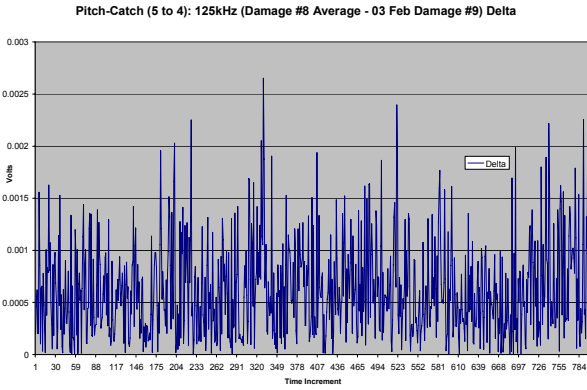

Pitch-Catch (Sensor 5 to 4): 03 Feb 07 Run 2, Damage 9 – 1/16” Hole, Centered, 100mm Offset, Damage 8 Baseline

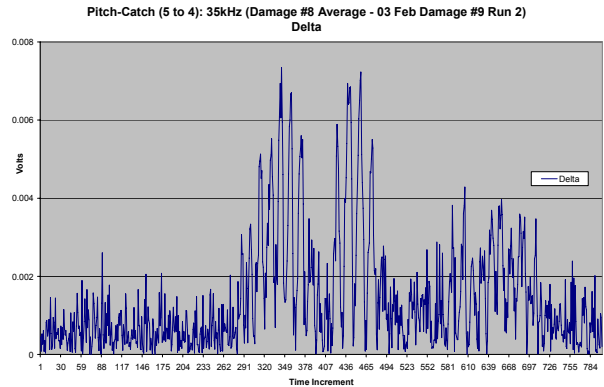
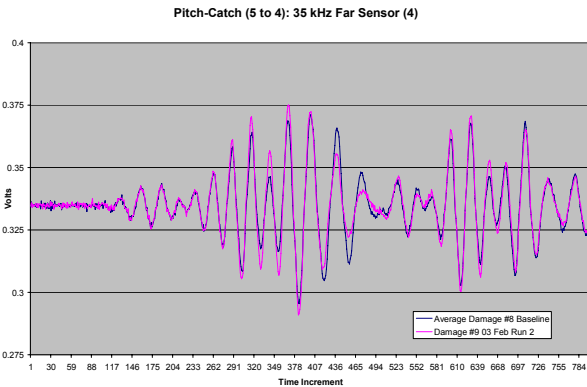

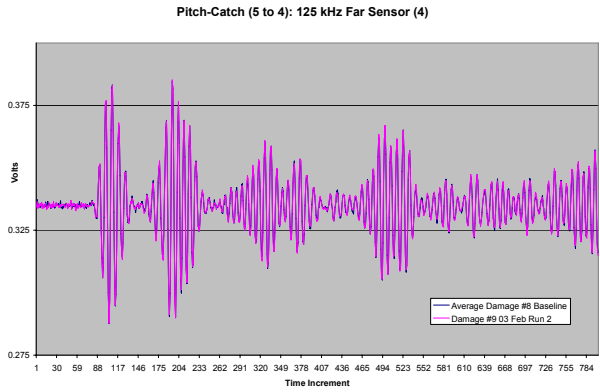
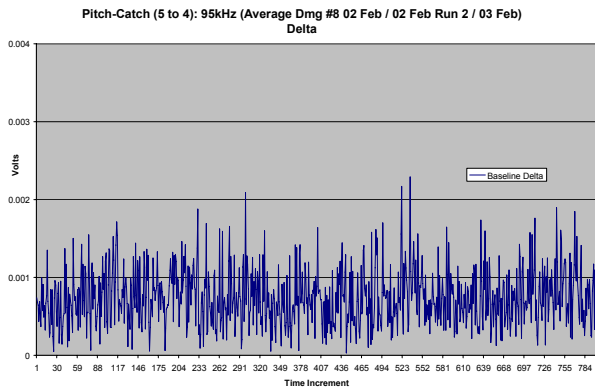
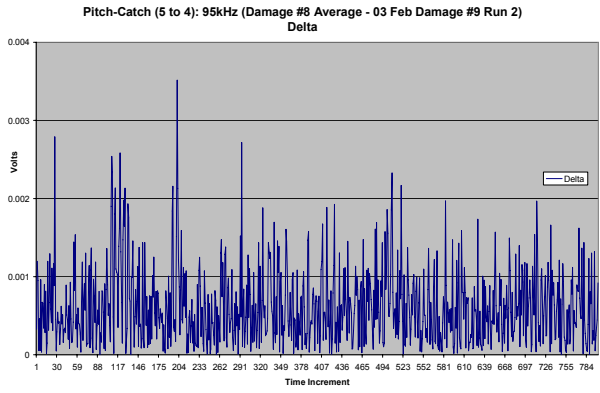
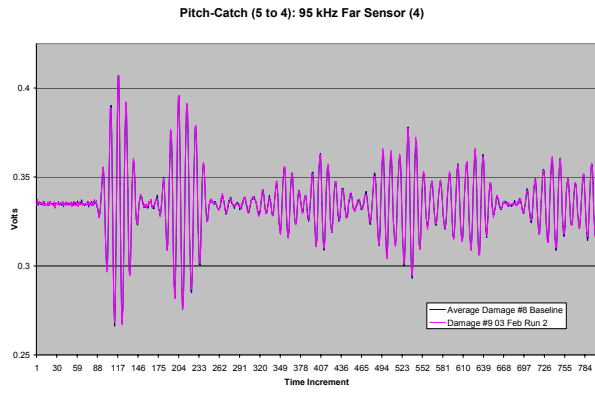
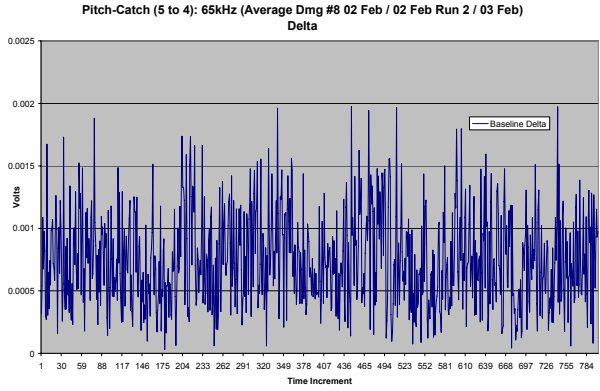
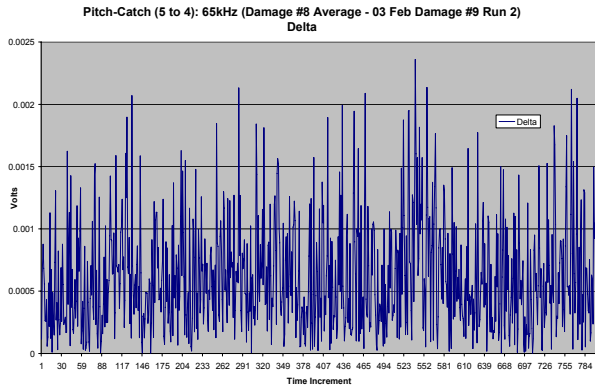
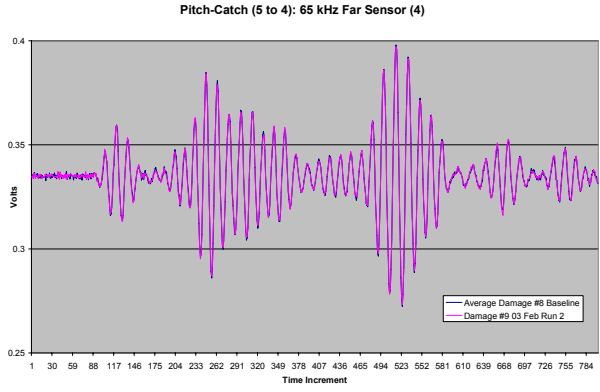
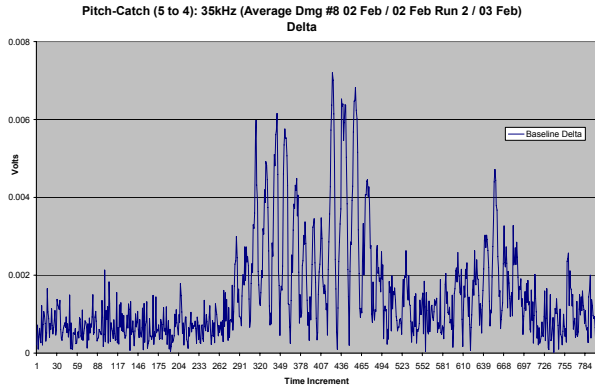

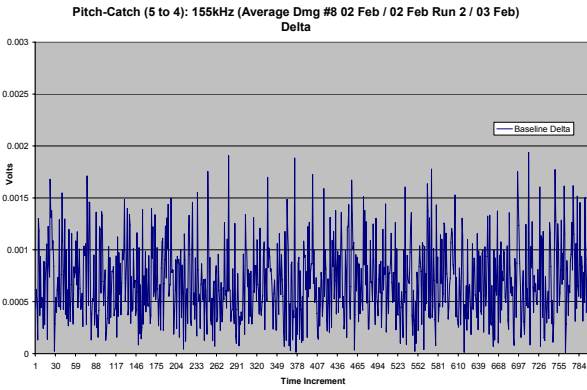
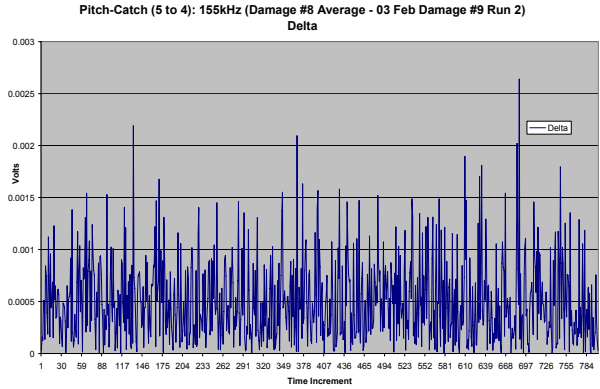
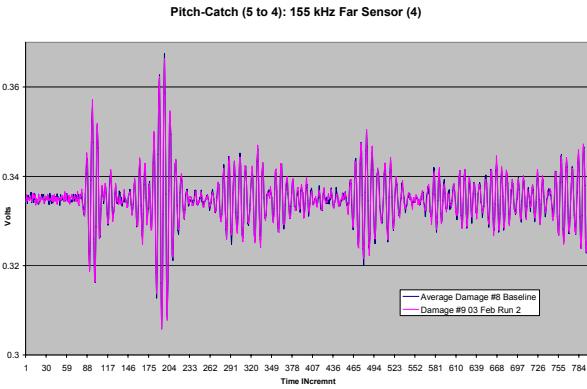
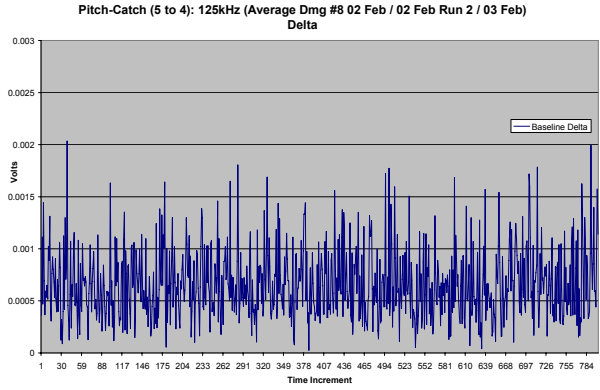
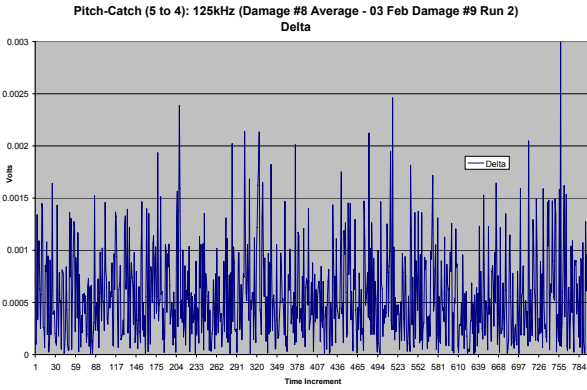

Pitch-Catch (Sensor 5 to 4): 03 Feb 07, Damage 10 – 1/4” Hole, Centered, 100mm Offset
Damage 9 Baseline

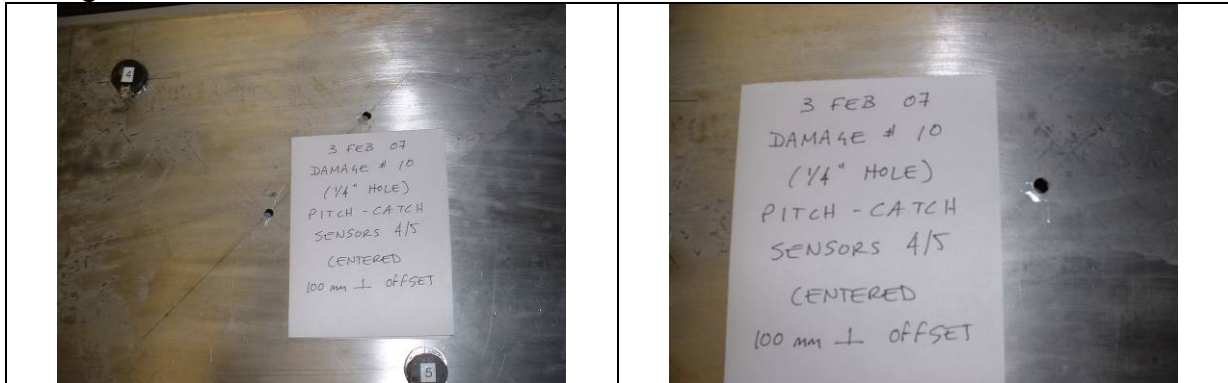

Pitch-Catch (5 to 4): 35 kHz Far Sensor (4)

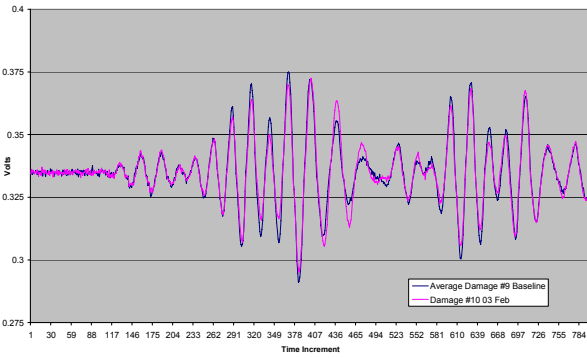

Pitch-Catch (5 to 4): 35kHz (Damage #9 Average - 03 Feb Damage #10) Delta

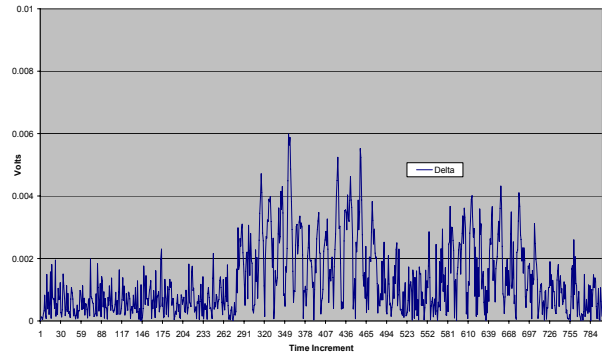

Pitch-Catch (5 to 4): 35kHz (Average Damage #9 03 Feb / 03 Feb Run 2) Delta

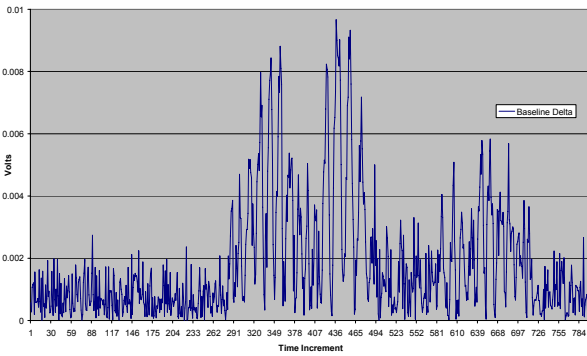

Pitch-Catch (5 to 4): 65 kHz Far Sensor (4)

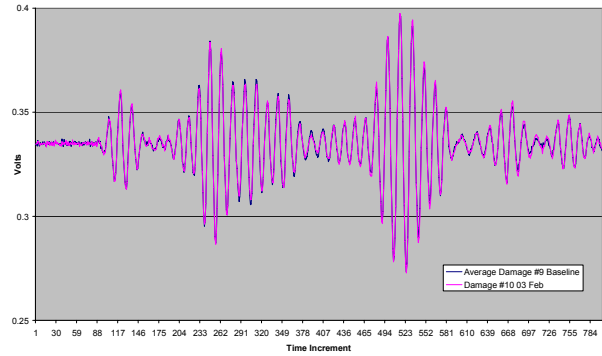

Pitch-Catch (5 to 4): 65kHz (Damage #9 Average - 03 Feb Damage #10) Delta

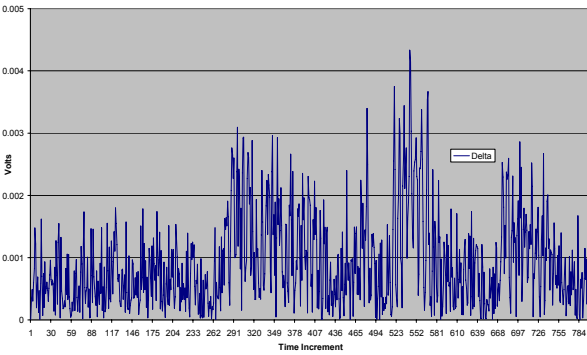

Pitch-Catch (5 to 4): 65kHz (Average Damage #9 03 Feb / 03 Feb Run 2) Delta

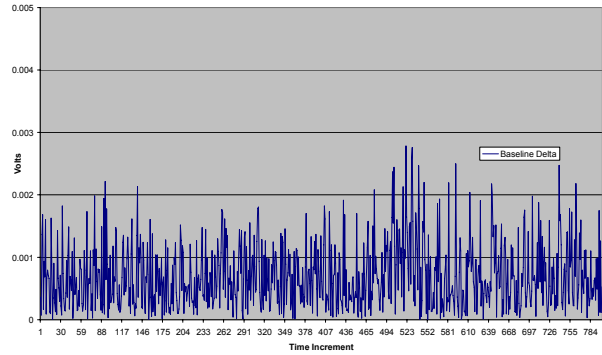

Pitch-Catch (5 to 4): 95 kHz Far Sensor (4)

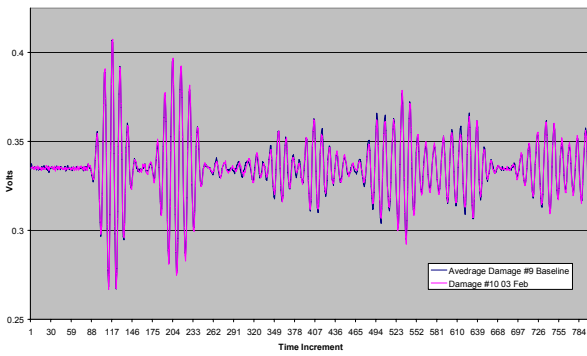

Pitch-Catch (5 to 4): 95kHz (Damage #9 Average - 03 Feb Damage #10) Delta

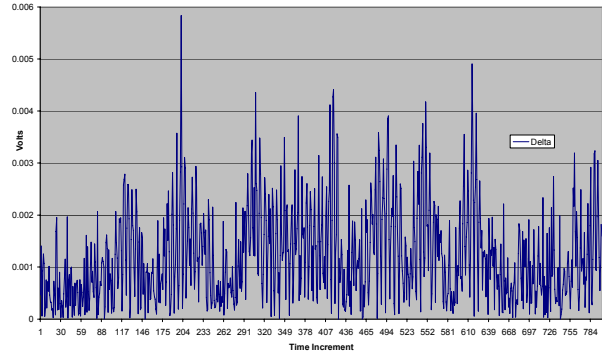

Pitch-Catch (5 to 4): 95kHz (Average Damage #9 03 Feb / 03 Feb Run 2) Delta

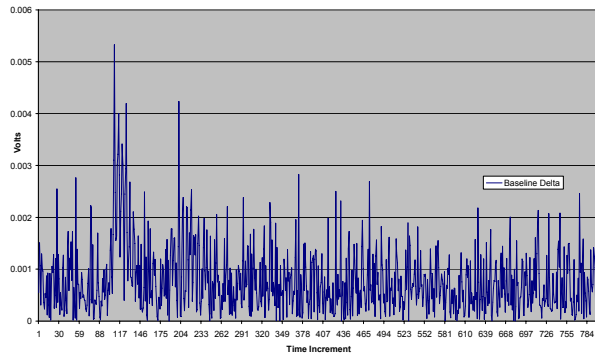

Pitch-Catch (5 to 4): 125 kHz Far Sensor (4)

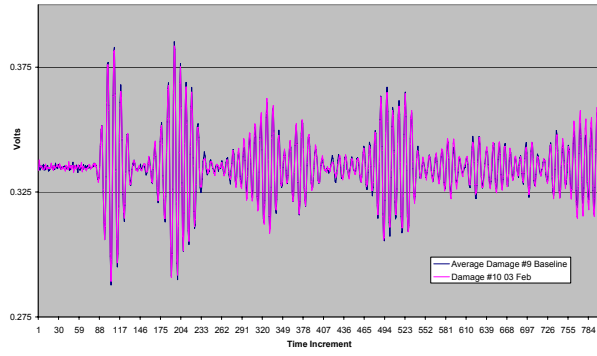

Pitch-Catch (5 to 4): 125kHz (Damage #9 Average - 03 Feb Damage #10) Delta

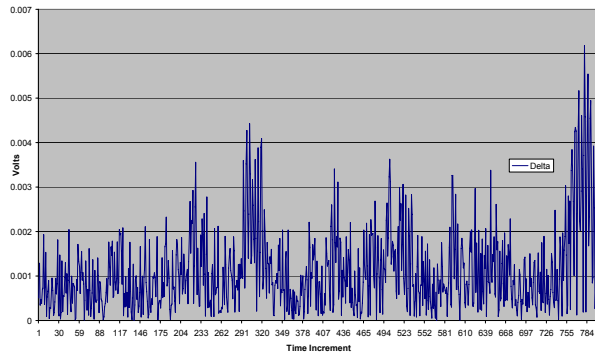

Pitch-Catch (5 to 4): 125kHz (Average Damage #9 03 Feb / 03 Feb Run 2) Delta

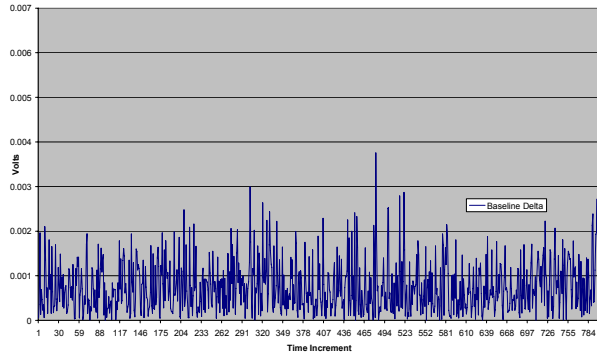

Pitch-Catch (5 to 4): 155 kHz Far Sensor (4)

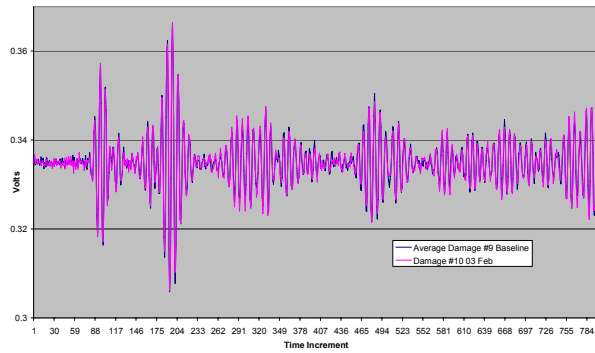

Pitch-Catch (5 to 4): 155kHz (Damage #9 Average - 03 Feb Damage #10) Delta

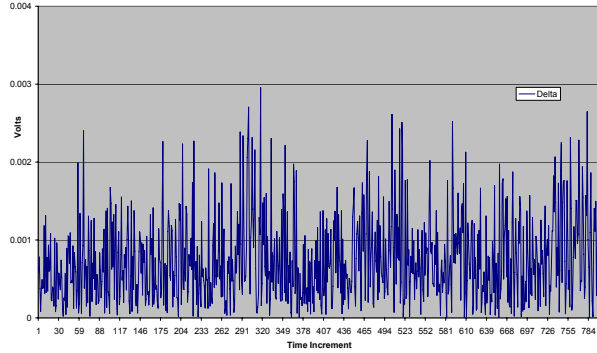

Pitch-Catch (5 to 4): 155kHz (Average Damage #9 03 Feb / 03 Feb Run 2) Delta

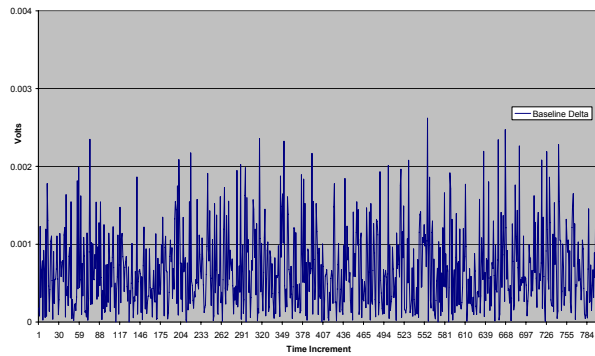

Pitch-Catch (Sensor 5 to 4): 04 Feb 07, Damage 10 – 1/4” Hole, Centered, 100mm Offset Damage 9 Baseline

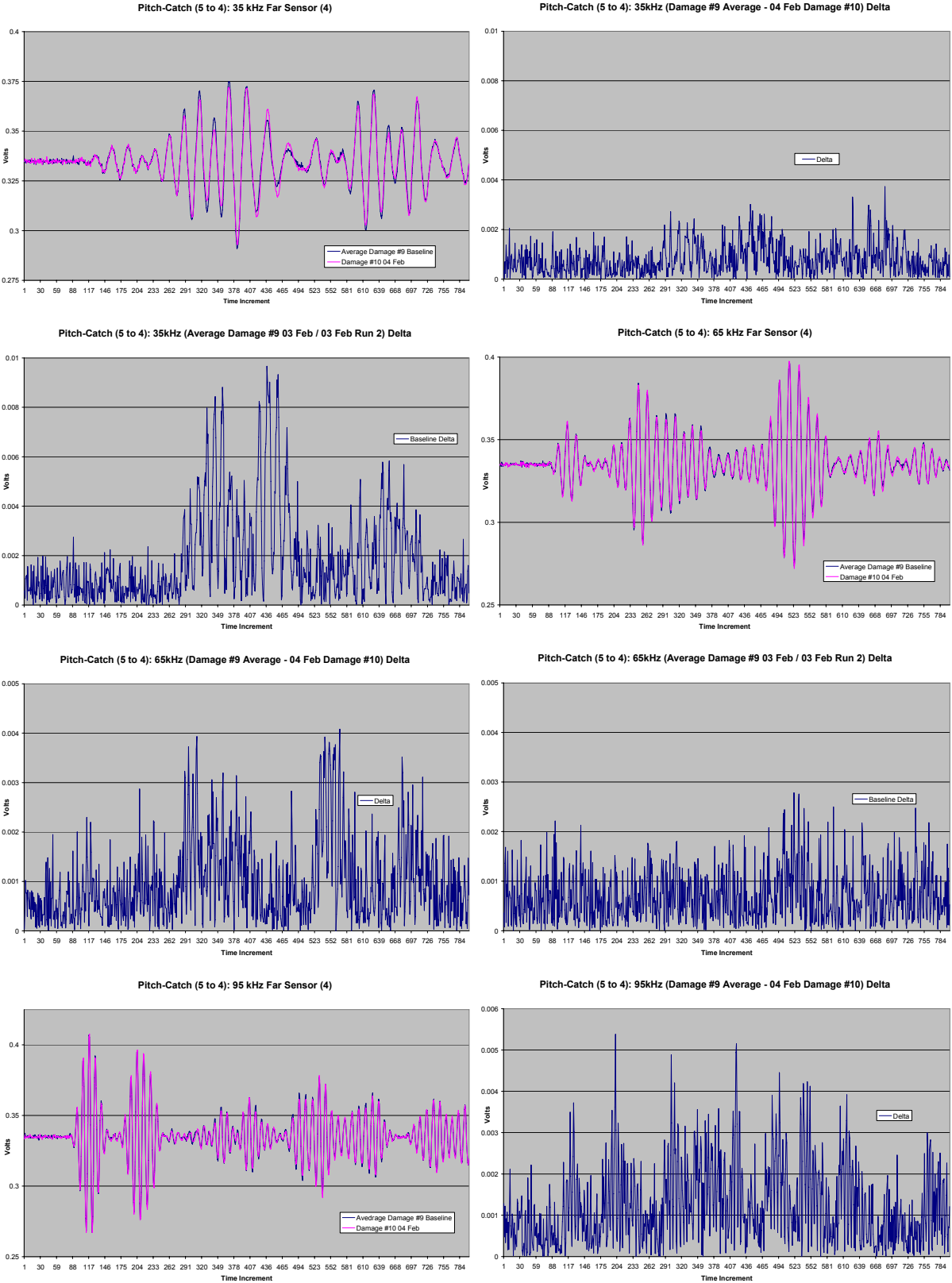

Pitch-Catch (5 to 4): 95kHz (Average Damage #9 03 Feb / 03 Feb Run 2) Delta

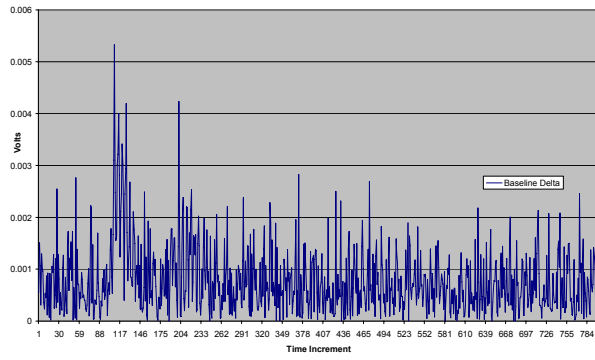

Pitch-Catch (5 to 4): 125 kHz Far Sensor (4)

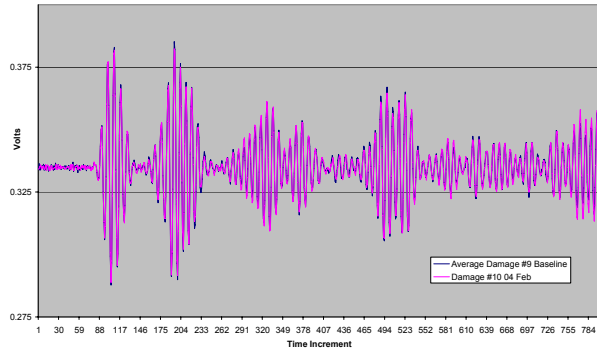

Pitch-Catch (5 to 4): 125kHz (Damage #9 Average - 04 Feb Damage #10) Delta

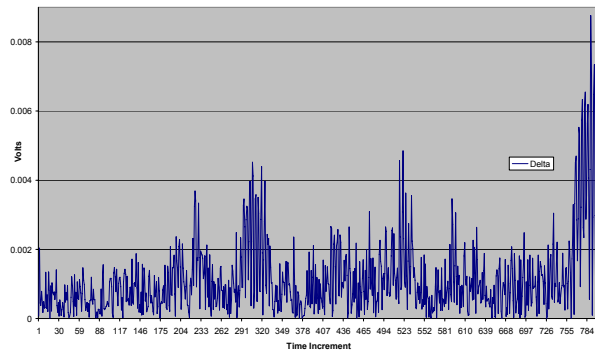

Pitch-Catch (5 to 4): 125kHz (Average Damage #9 03 Feb / 03 Feb Run 2) Delta

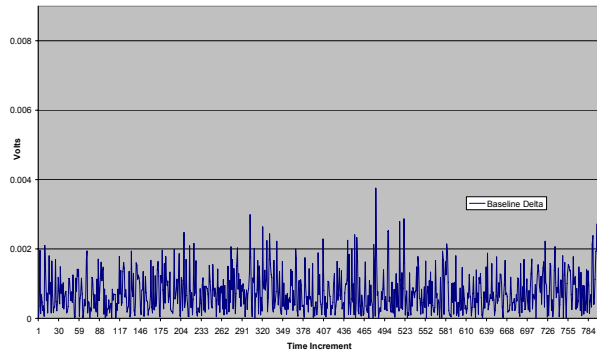

Pitch-Catch (5 to 4): 155 kHz Far Sensor (4)

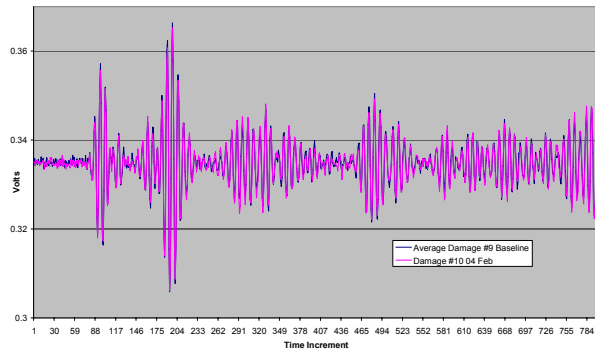

Pitch-Catch (5 to 4): 155kHz (Damage #9 Average - 04 Feb Damage #10) Delta

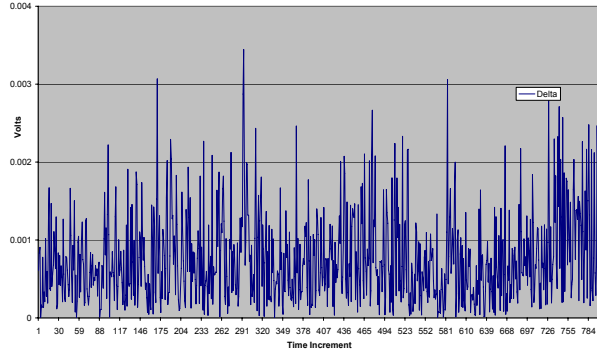

Pitch-Catch (5 to 4): 155kHz (Average Damage #9 03 Feb / 03 Feb Run 2) Delta

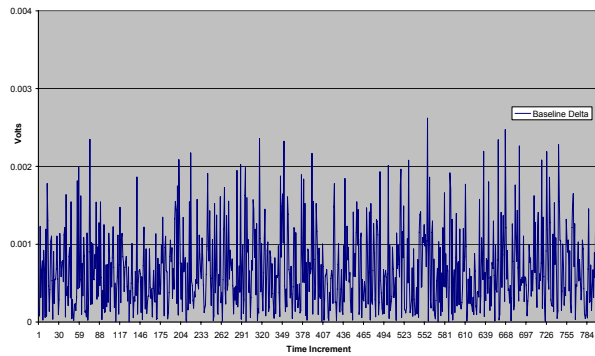

Pitch-Catch (Sensor 5 to 4): 04 Feb 07, Damage 11 – Punch (Impact), Centered, 100mm Offset
 Damage 10 Baseline

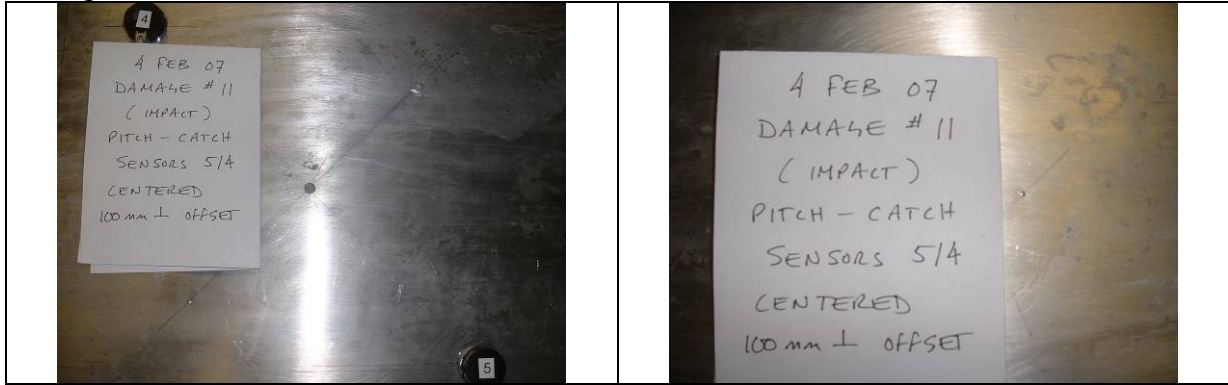

Pitch-Catch (5 to 4): 35 kHz Far Sensor (4)

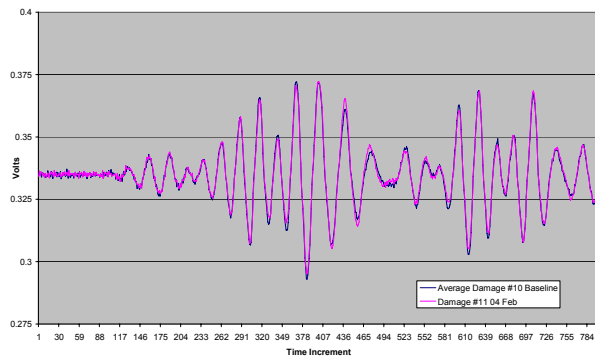

Pitch-Catch (5 to 4): 35kHz (Damage #10 Average - 04 Feb Damage #11) Delta

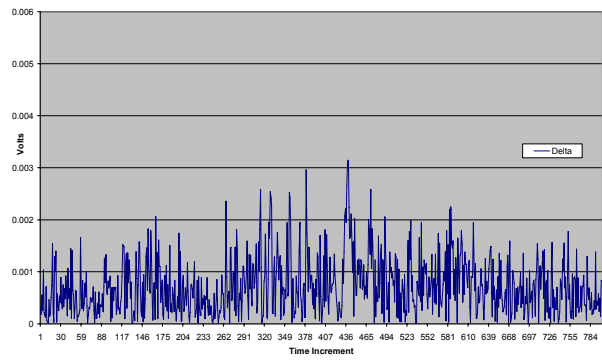

Pitch-Catch (5 to 4): 35kHz (Average Damage #10 03 Feb / 04 Feb) Delta

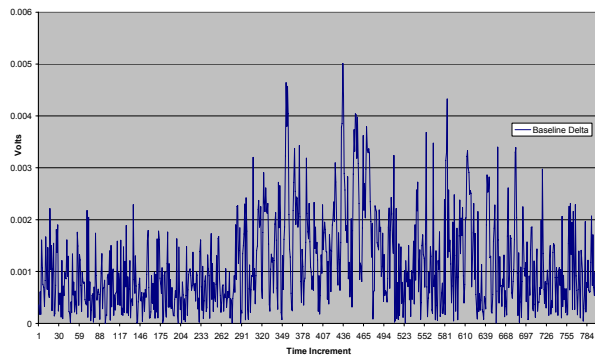

Pitch-Catch (5 to 4): 65 kHz Far Sensor (4)

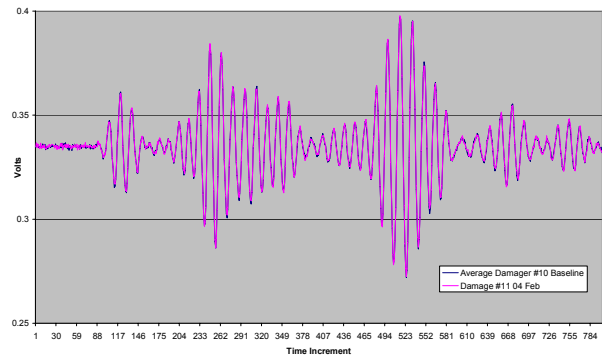

Pitch-Catch (5 to 4): 65kHz (Damage #10 Average - 04 Feb Damage #11) Delta

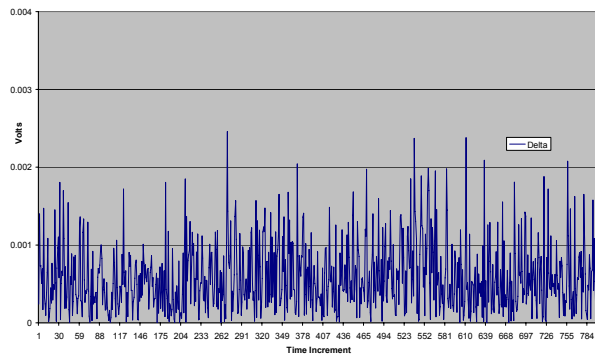

Pitch-Catch (5 to 4): 65kHz (Average Damage #10 03 Feb / 04 Feb) Delta

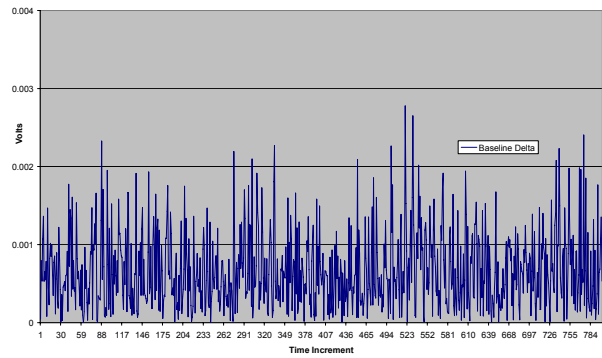

Pitch-Catch (5 to 4): 95 kHz Far Sensor (4)

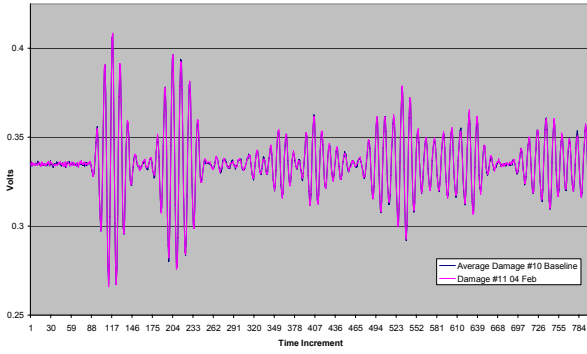

Pitch-Catch (5 to 4): 95kHz (Damage #10 Average - 04 Feb Damage #11) Delta

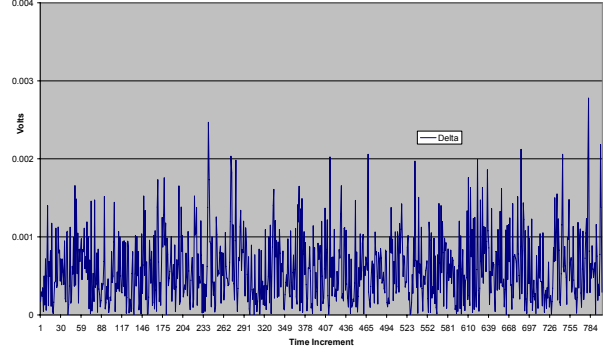

Pitch-Catch (5 to 4): 95kHz (Average Damage #10 03 Feb / 04 Feb) Delta

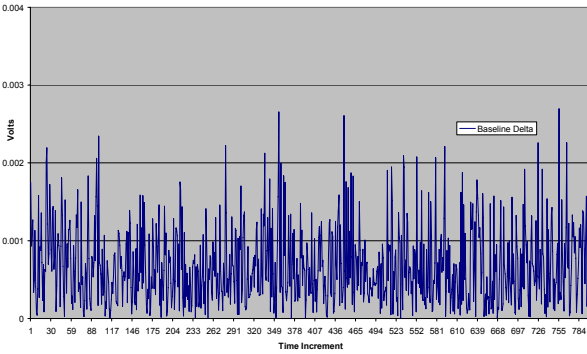

Pitch-Catch (5 to 4): 125 kHz Far Sensor (4)

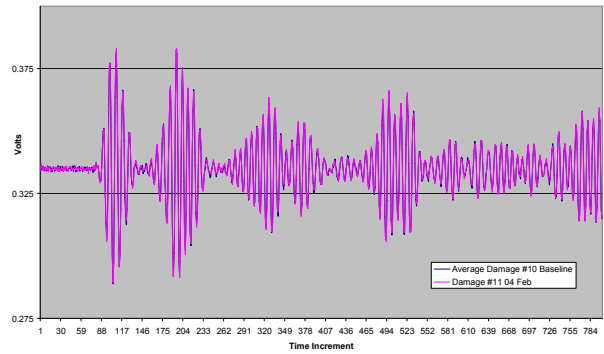

Pitch-Catch (5 to 4): 125kHz (Damage #10 Average - 04 Feb Damage #11) Delta

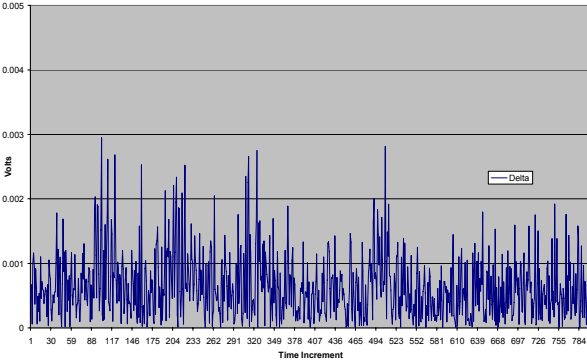

Pitch-Catch (5 to 4): 125kHz (Average Damage #10 03 Feb / 04 Feb) Delta

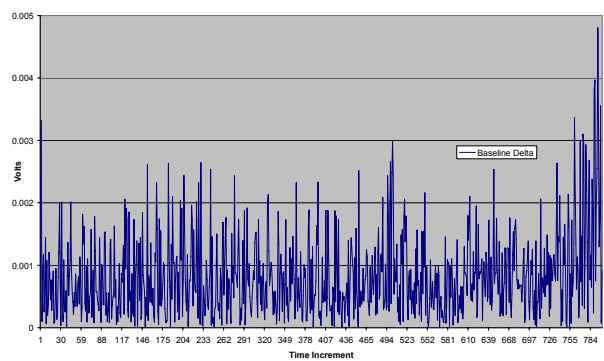

Pitch-Catch (5 to 4): 155 kHz Far Sensor (4)

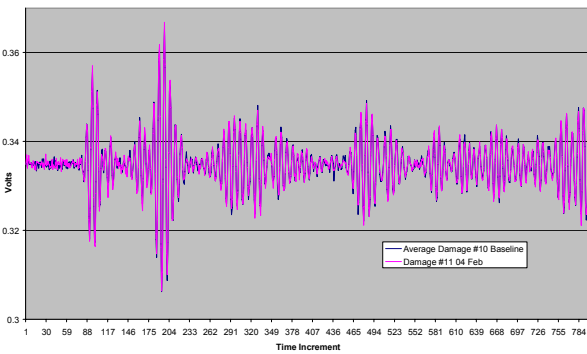

Pitch-Catch (5 to 4): 155kHz (Damage #10 Average - 04 Feb Damage #11) Delta

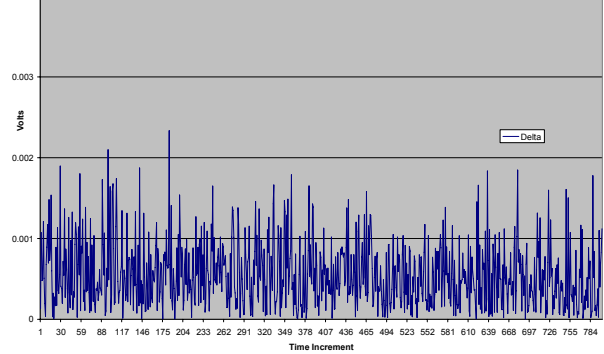

Pitch-Catch (5 to 4): 155kHz (Average Damage #10 03 Feb / 04 Feb) Delta

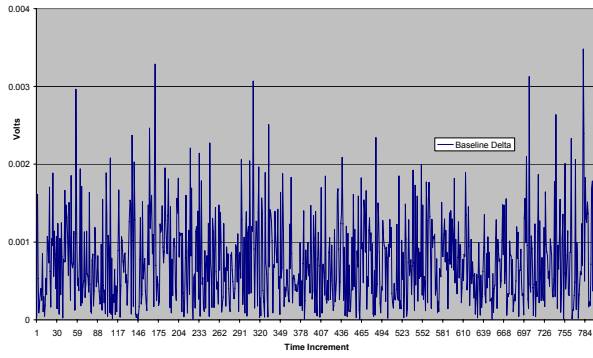

Pitch-Catch (Sensor 5 to 4): 04 Feb 07 Run 2, Damage 11 – Punch (Impact), Centered, 100mm Offset, Damage 10 Baseline

Pitch-Catch (5 to 4): 35 kHz Far Sensor (4)

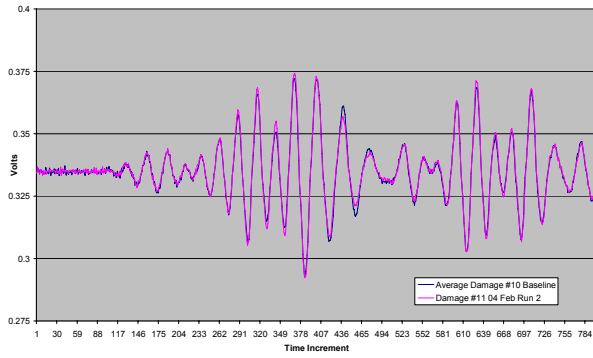

Pitch-Catch (5 to 4): 35kHz (Damage #10 Average - 04 Feb Damage #11 Run 2) Delta

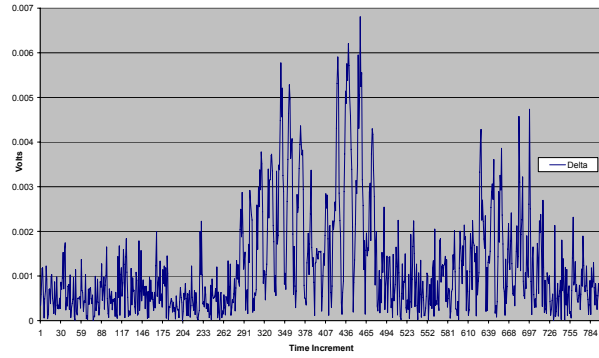

Pitch-Catch (5 to 4): 35kHz (Average Damage #10 03 Feb / 04 Feb) Delta

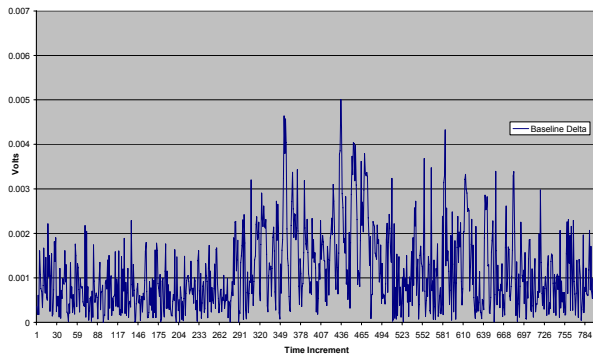

Pitch-Catch (5 to 4): 65 kHz Far Sensor (4)

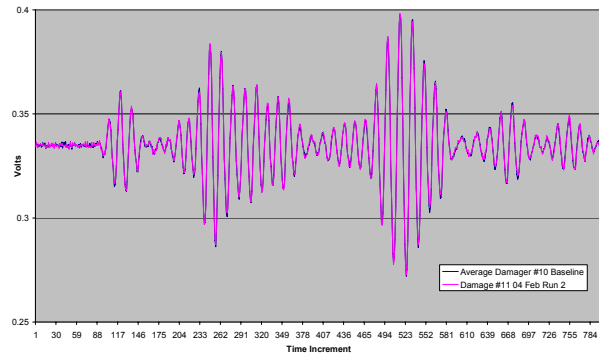

Pitch-Catch (5 to 4): 65kHz (Damage #10 Average - 04 Feb Damage #11 Run 2) Delta

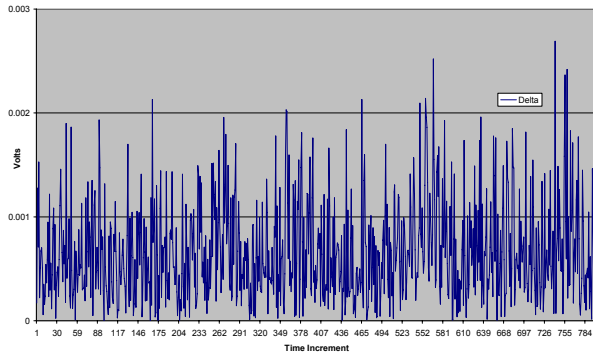

Pitch-Catch (5 to 4): 65kHz (Average Damage #10 03 Feb / 04 Feb) Delta

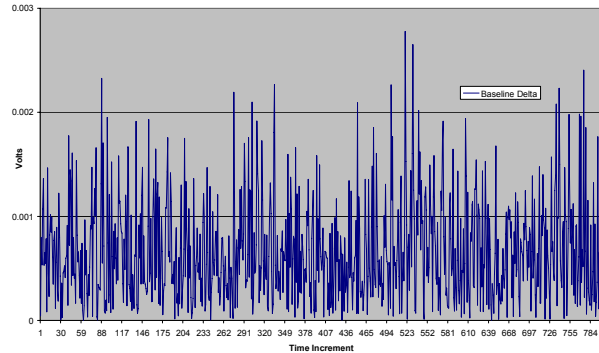

Pitch-Catch (5 to 4): 95 kHz Far Sensor (4)

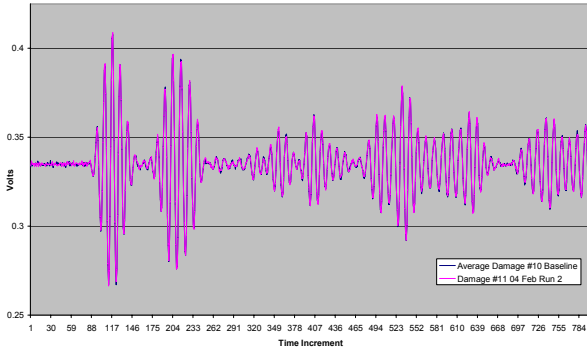

Pitch-Catch (5 to 4): 95kHz (Damage #10 Average - 04 Feb Damage #11 Run 2) Delta

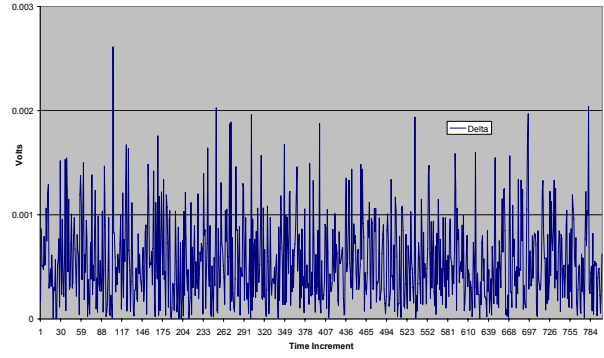

Pitch-Catch (5 to 4): 95kHz (Average Damage #10 03 Feb / 04 Feb) Delta

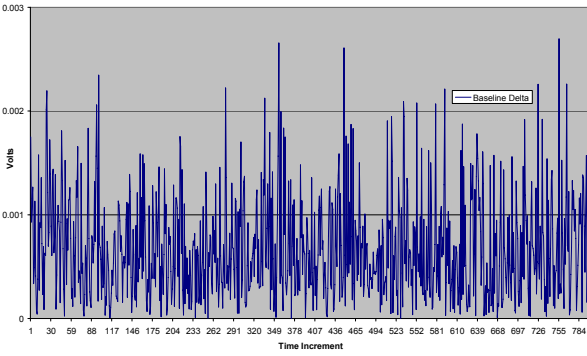

Pitch-Catch (5 to 4): 125 kHz Far Sensor (4)

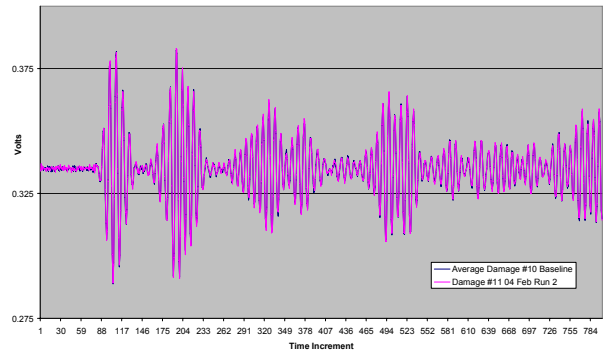

Pitch-Catch (5 to 4): 125kHz (Dmg #10 Average - 04 Feb Dmg #11 Run 2) Delta

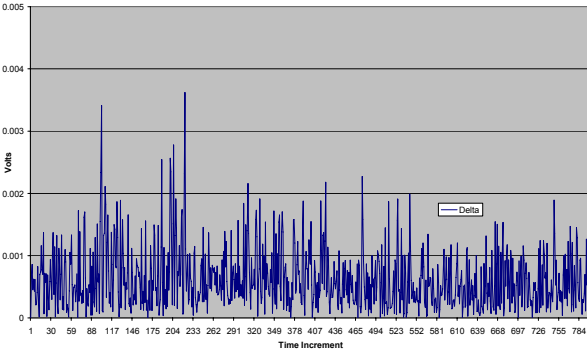

Pitch-Catch (5 to 4): 125kHz (Average Damage #10 03 Feb / 04 Feb) Delta

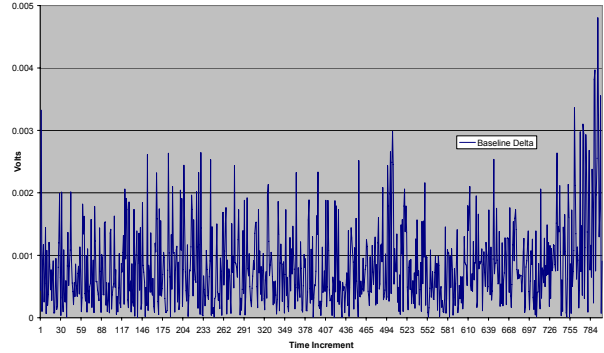

Pitch-Catch (5 to 4): 155 kHz Far Sensor (4)

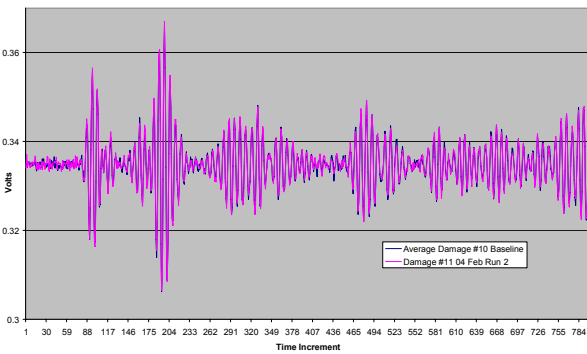

Pitch-Catch (5 to 4): 155kHz (Dmg #10 Average - 04 Feb Dmg #11 Run 2) Delta

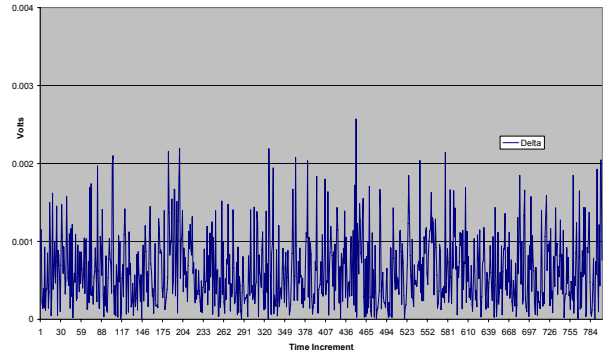

Pitch-Catch (5 to 4): 155kHz (Average Damage #10 03 Feb / 04 Feb) Delta

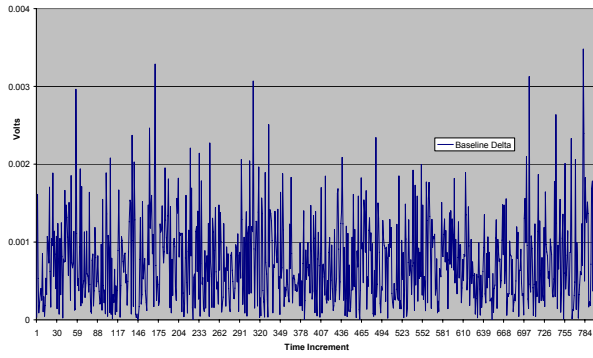

Pitch-Catch (Sensor 5 to 4): 05 Feb 07, Damage 11 – Punch (Impact), Centered, 100mm Offset Damage 10 Baseline

Pitch-Catch (5 to 4): 35 kHz Far Sensor (4)

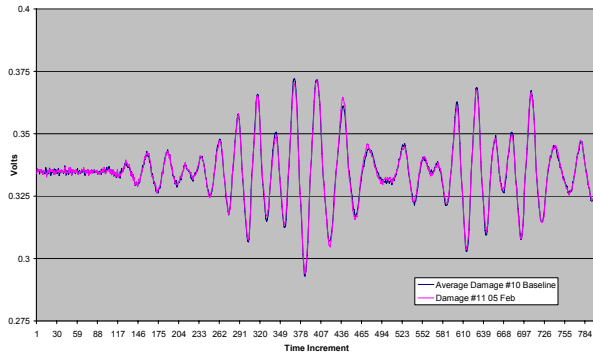

Pitch-Catch (5 to 4): 35kHz (Damage #10 Average - 05 Feb Damage #11) Delta

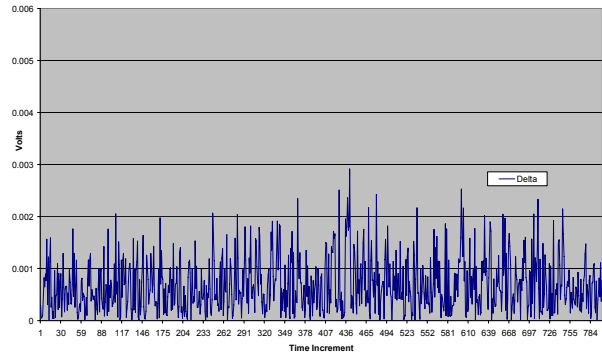

Pitch-Catch (5 to 4): 35kHz (Average Damage #10 03 Feb / 04 Feb) Delta

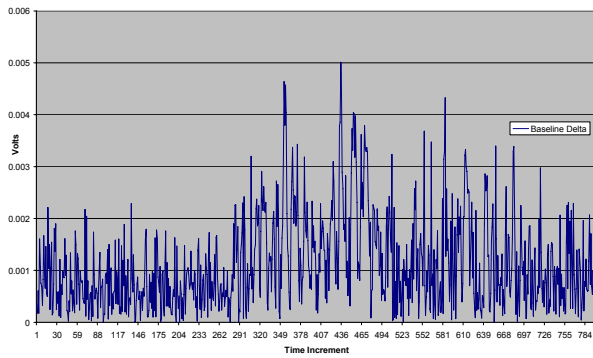

Pitch-Catch (5 to 4): 65 kHz Far Sensor (4)

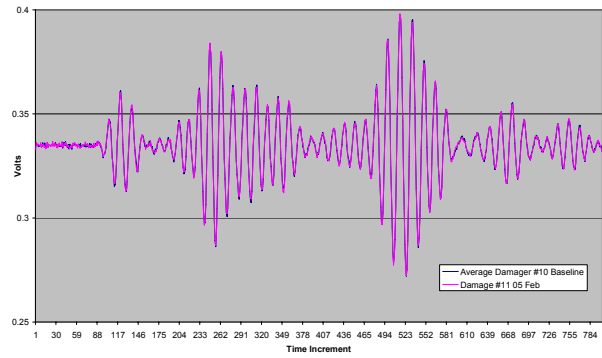

Pitch-Catch (5 to 4): 65kHz (Damage #10 Average - 05 Feb Damage #11) Delta

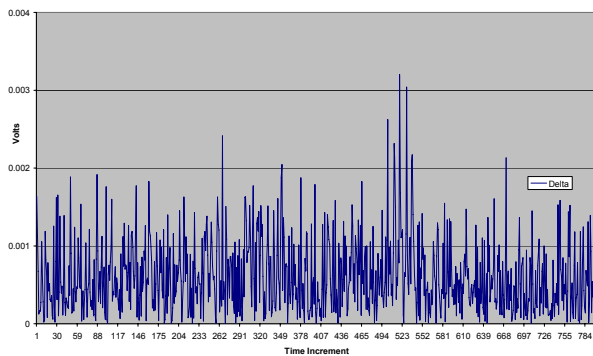

Pitch-Catch (5 to 4): 65kHz (Average Damage #10 03 Feb / 04 Feb) Delta

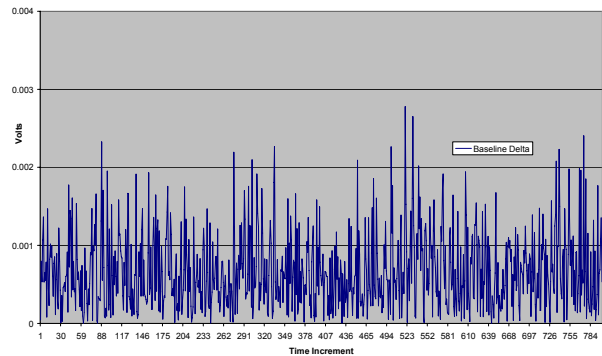

Pitch-Catch (5 to 4): 95 kHz Far Sensor (4)

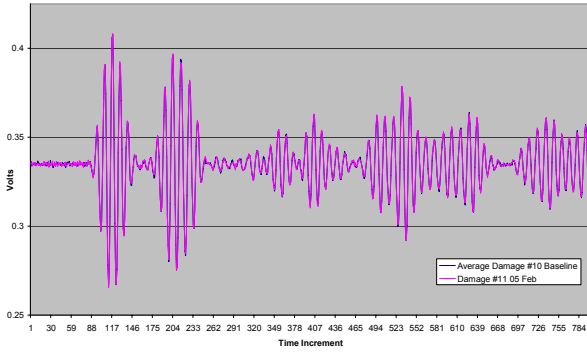

Pitch-Catch (5 to 4): 95kHz (Damage #10 Average - 05 Feb Damage #11) Delta

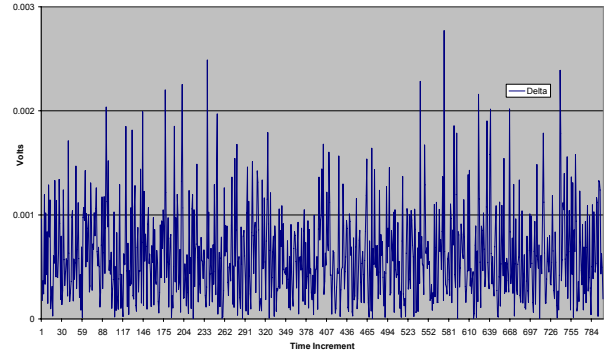

Pitch-Catch (5 to 4): 95kHz (Average Damage #10 03 Feb / 04 Feb) Delta

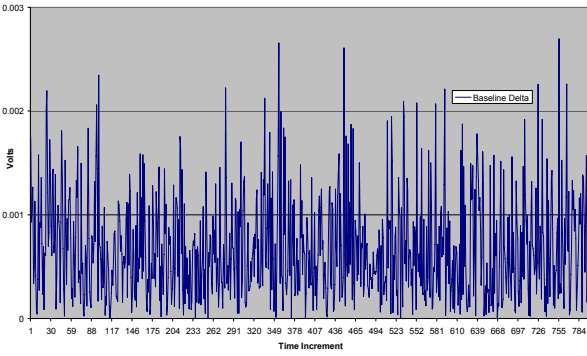

Pitch-Catch (5 to 4): 125 kHz Far Sensor (4)

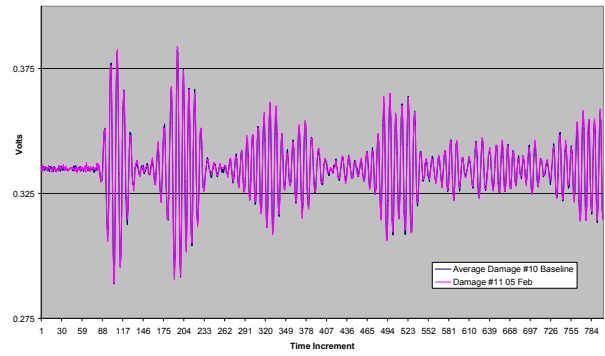

Pitch-Catch (5 to 4): 125kHz (Dmg #10 Average - 05 Feb Dmg #11) Delta

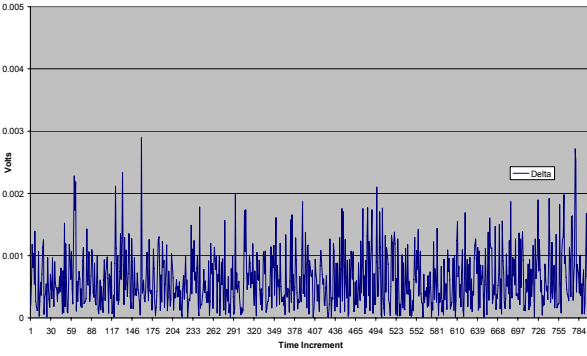

Pitch-Catch (5 to 4): 125kHz (Average Damage #10 03 Feb / 04 Feb) Delta

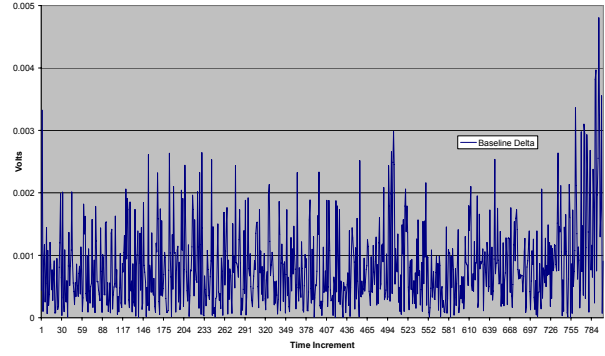

Pitch-Catch (5 to 4): 155 kHz Far Sensor (4)

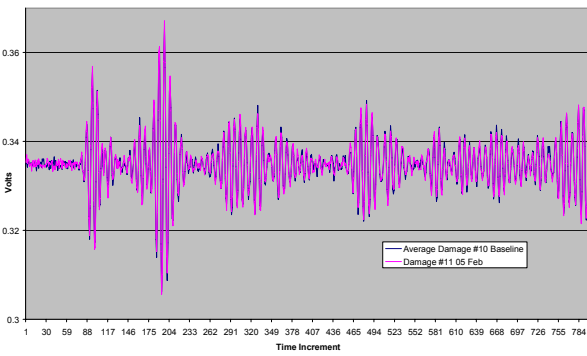

Pitch-Catch (5 to 4): 155kHz (Dmg #10 Average - 05 Feb Dmg #11) Delta

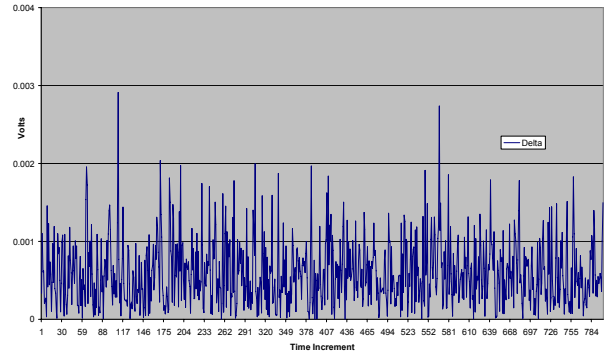

Pitch-Catch (5 to 4): 155kHz (Average Damage #10 03 Feb / 04 Feb) Delta

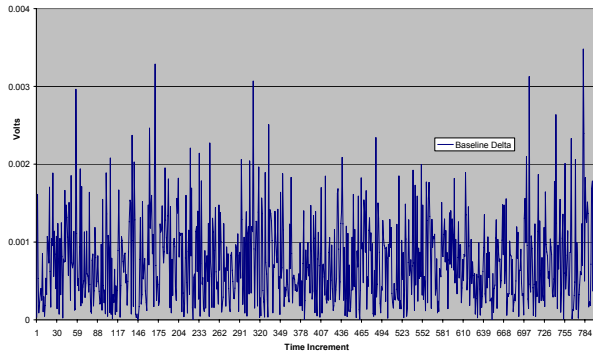

Pitch-Catch (Sensor 5 to 4): 05 Feb 07, Damage 12 – 1/4” Hole, Centered, 100mm Offset
 Damage 11 Baseline



Pitch-Catch (5 to 4): 35 kHz Far Sensor (4)

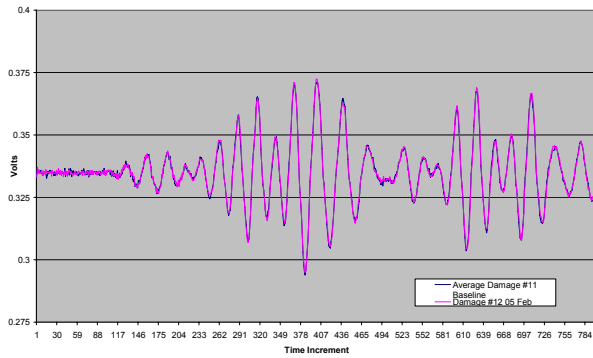

Pitch-Catch (5 to 4): 35kHz (Damage #11 Average - 05 Feb Damage #12) Delta

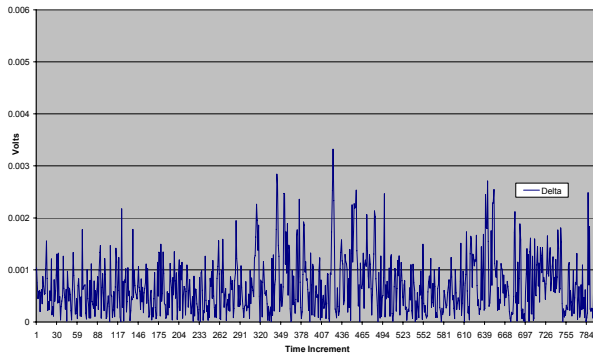

Pitch-Catch (5 to 4): 35kHz (Average Dmg #11 04 Feb / 04 Feb Run 2 / 05 Feb) Delta

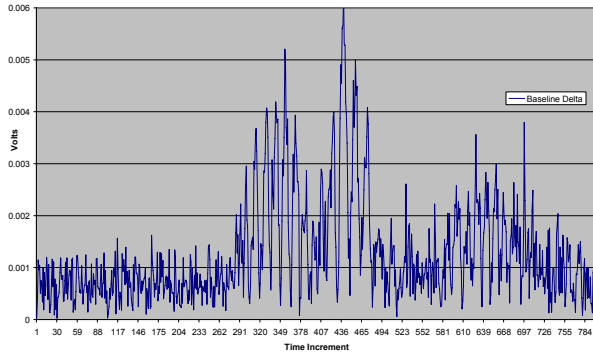

Pitch-Catch (5 to 4): 65 kHz Far Sensor (4)

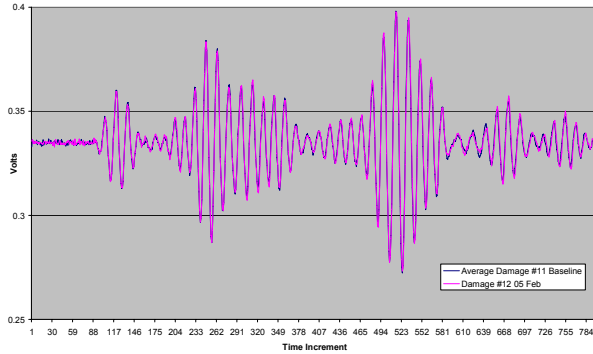

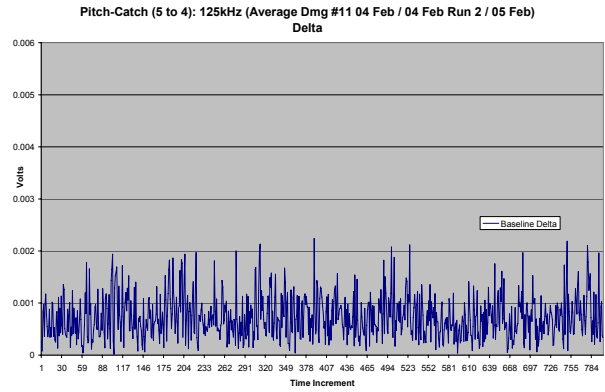
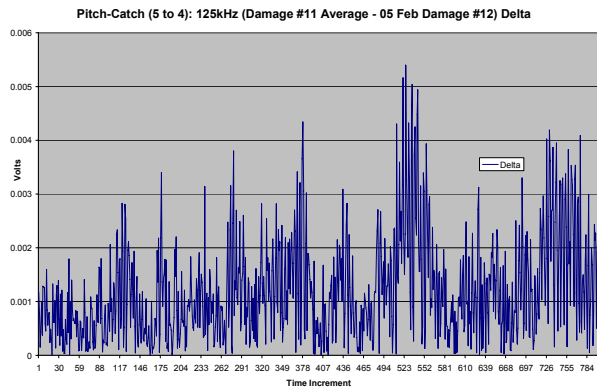
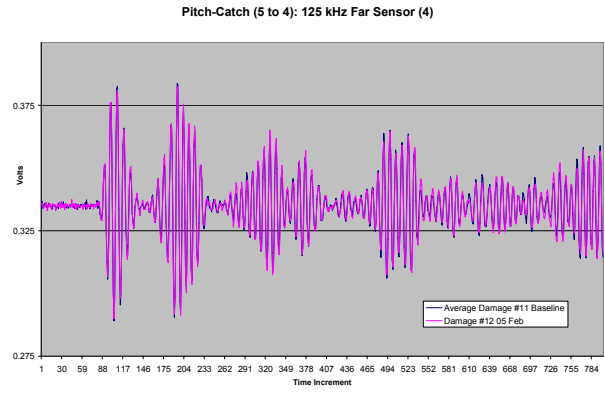
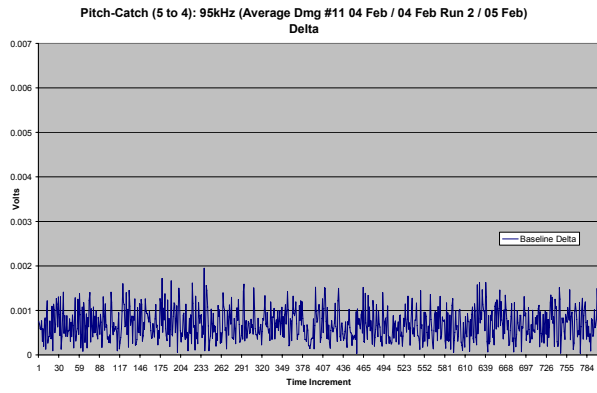
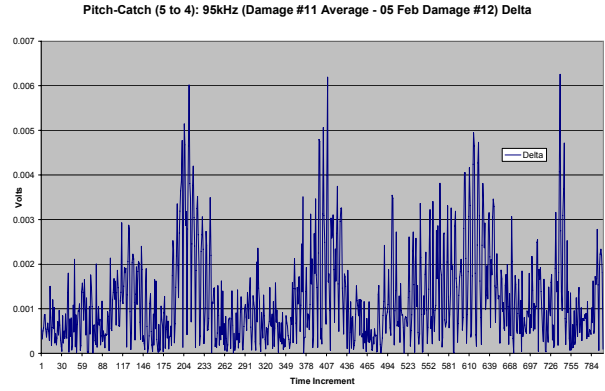
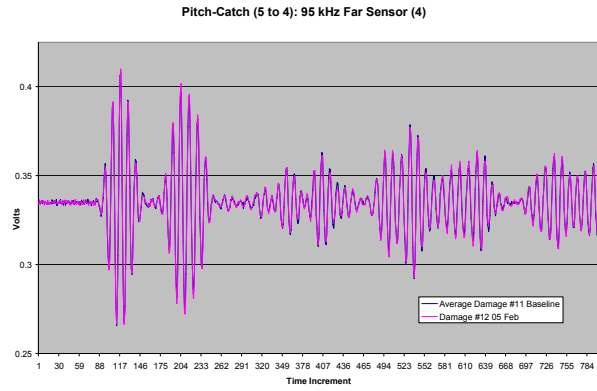
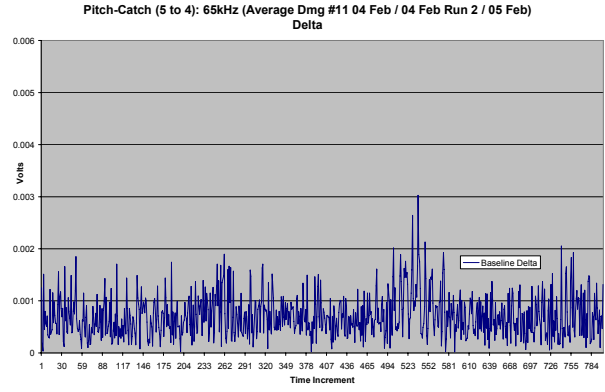
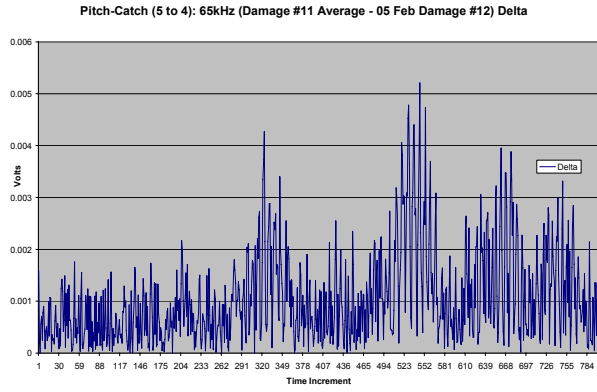

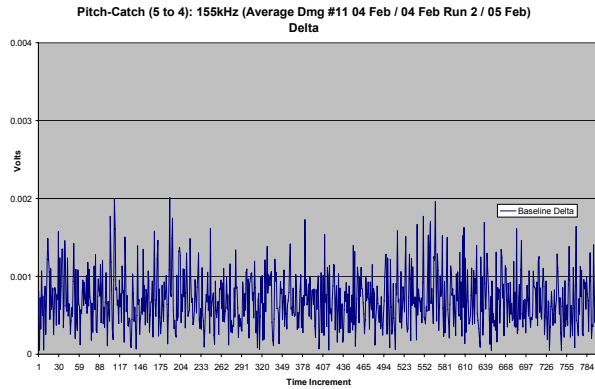
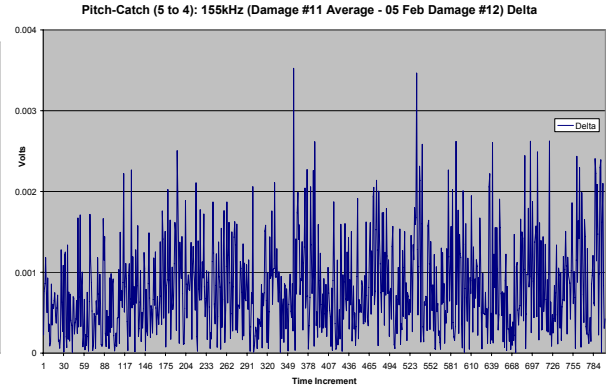
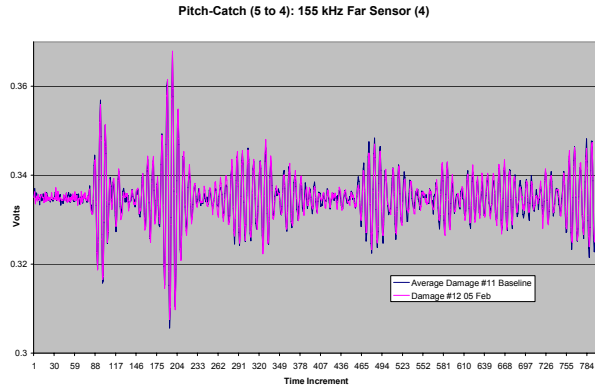

Pitch-Catch (Sensor 5 to 4): 06 Feb 07, Damage 12 – 1/4” Hole, Centered, 100mm Offset Damage 11 Baseline

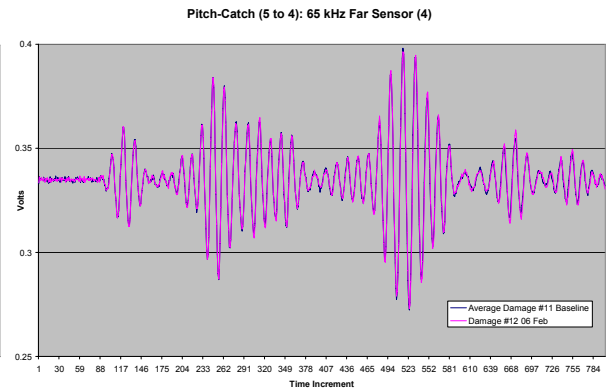
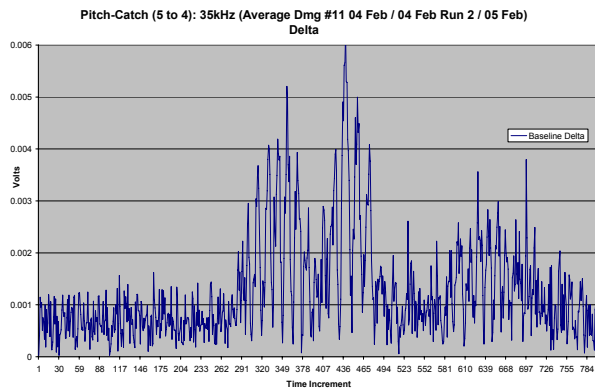
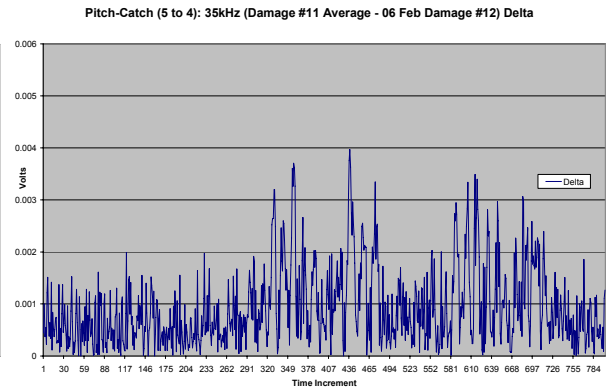
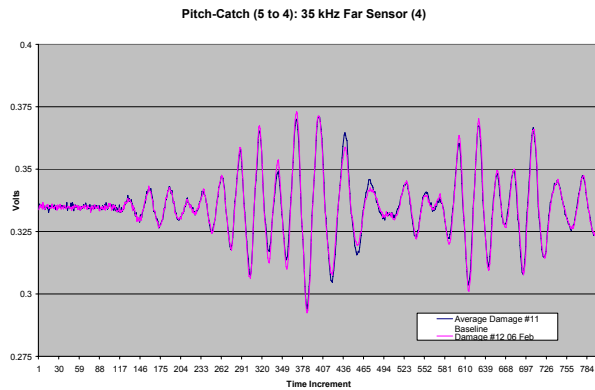

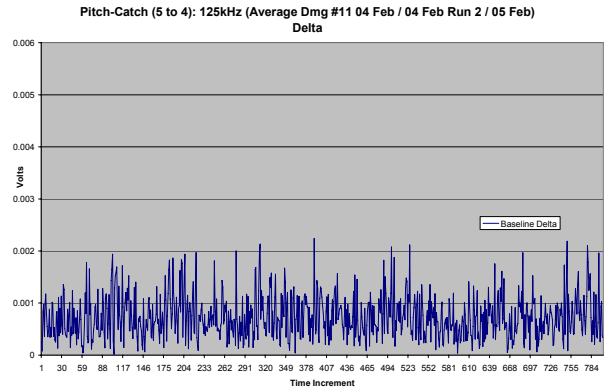
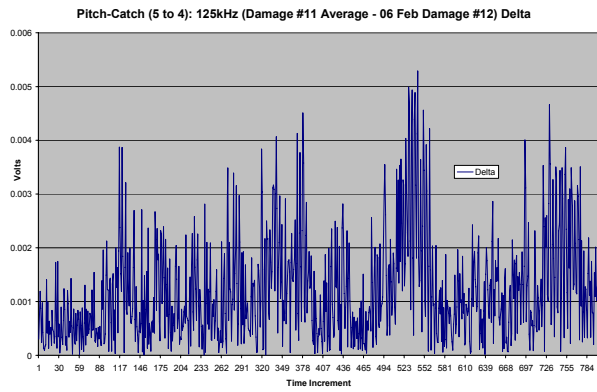
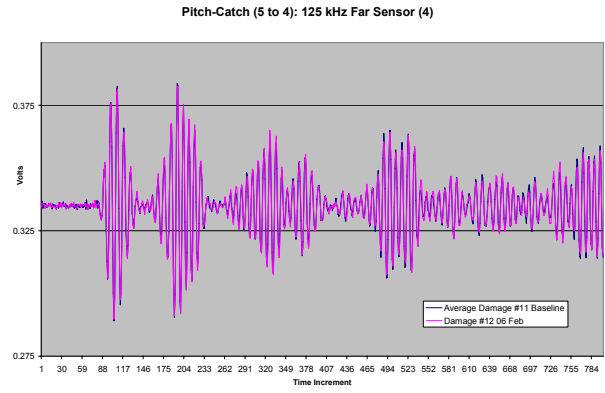
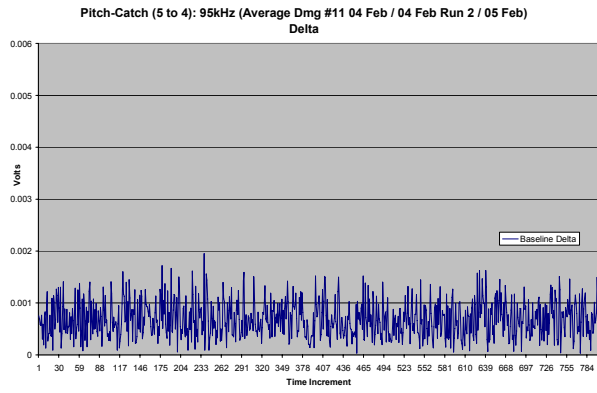
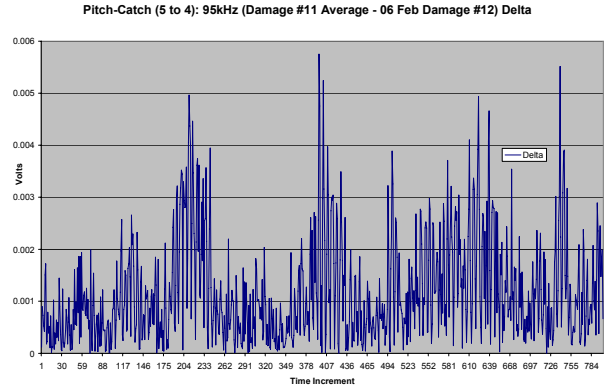
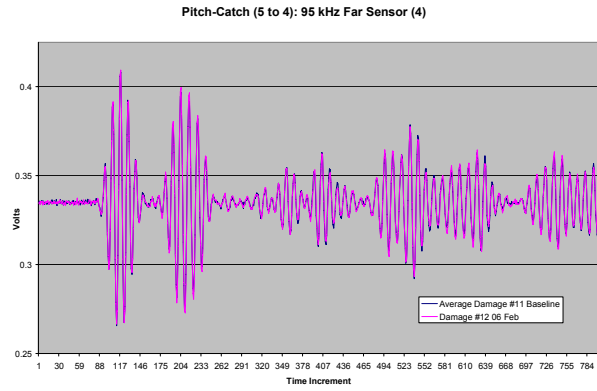
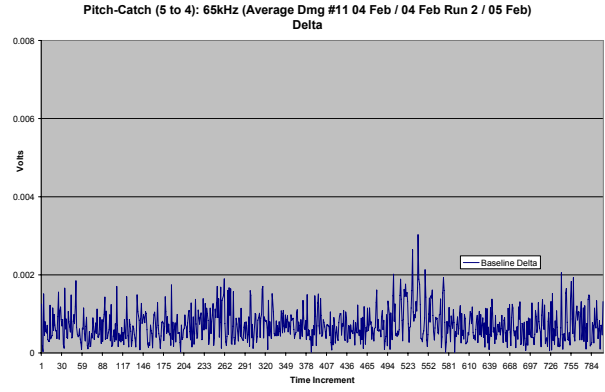
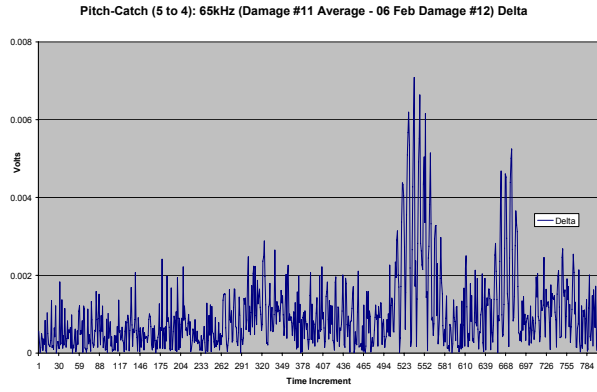

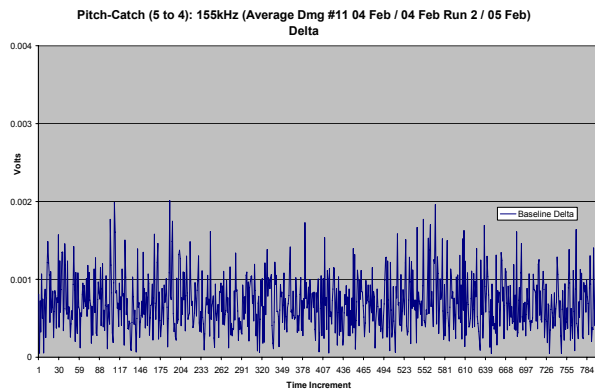
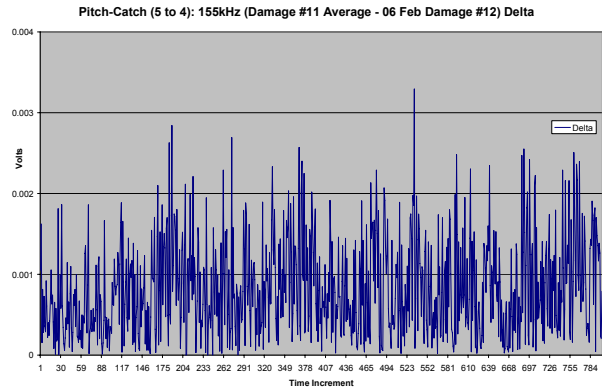
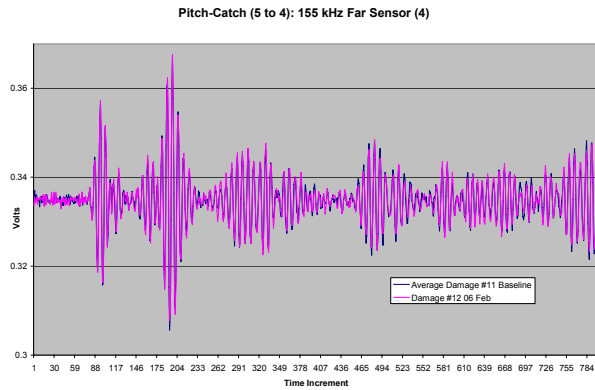

Pitch-Catch (Sensor 5 to 4): 09 Feb 07, Damage 13 – 5mm Gouge, 65mm from Sensor 5, No Offset, Damage 12 Baseline

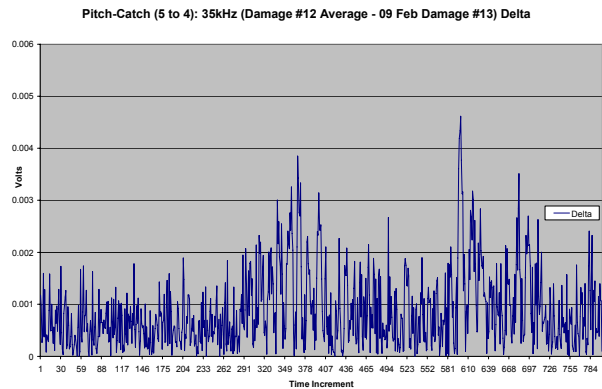
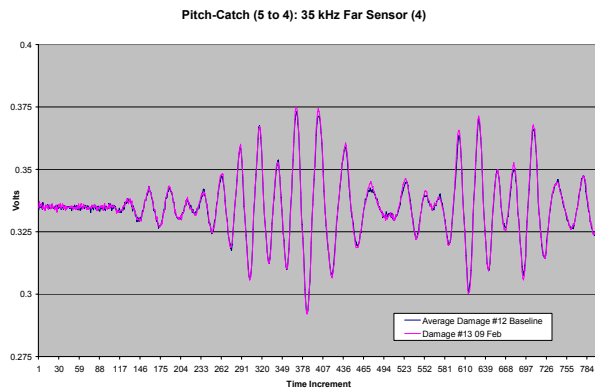

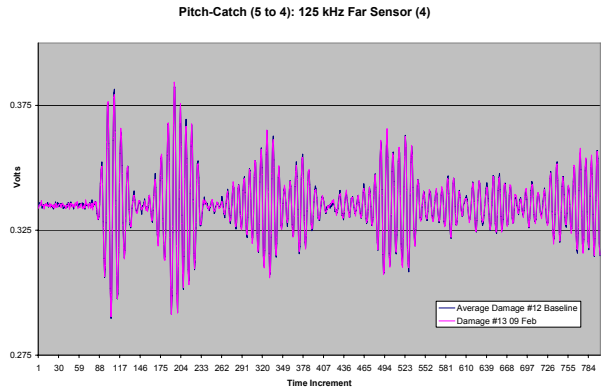
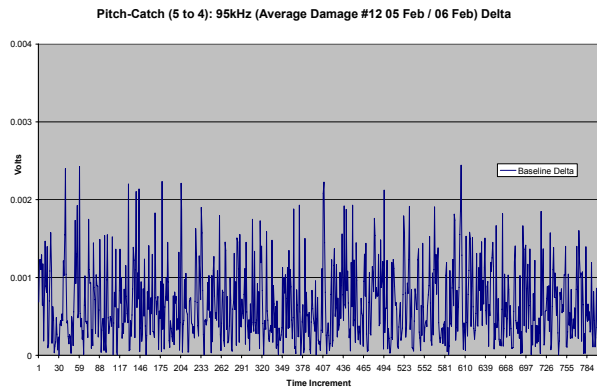
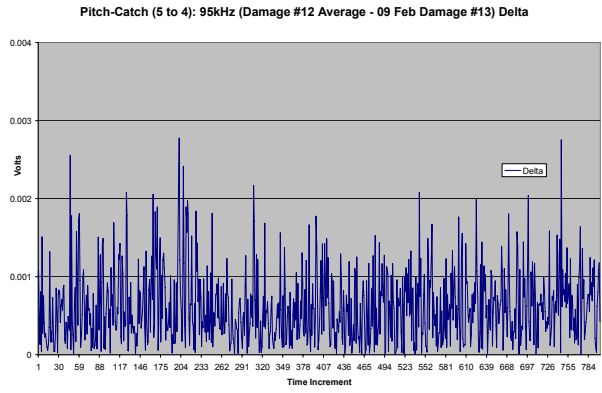
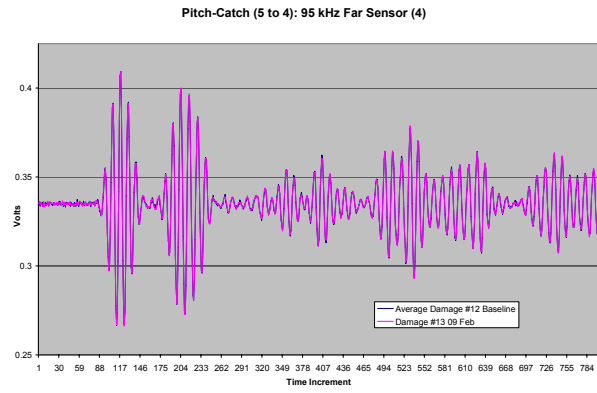
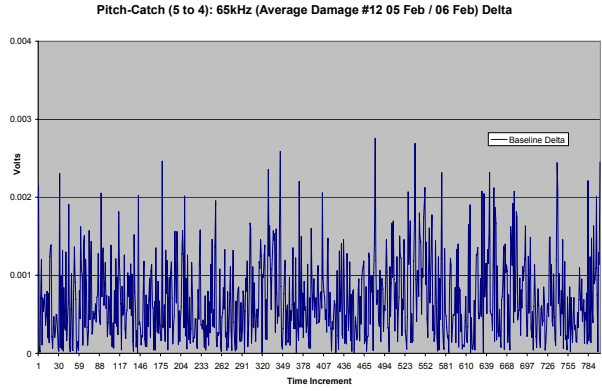
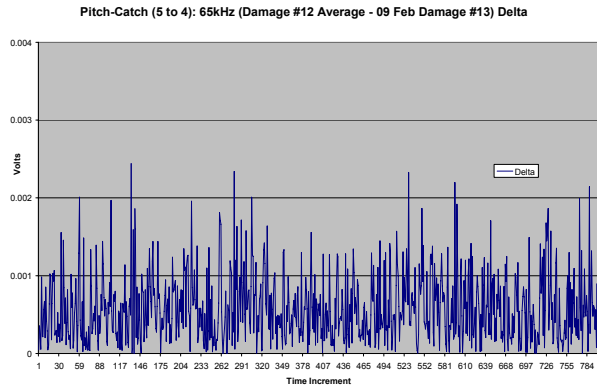
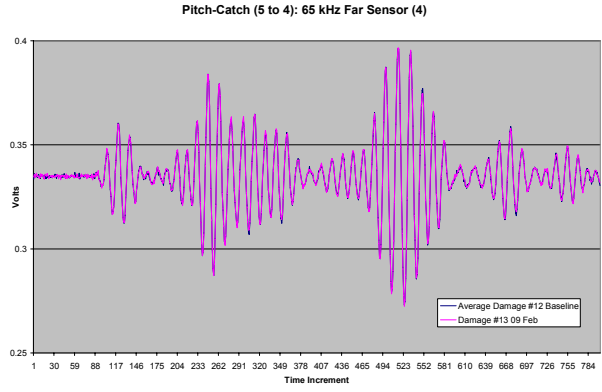
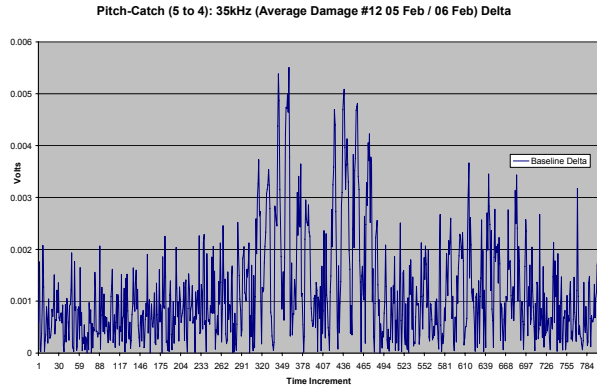

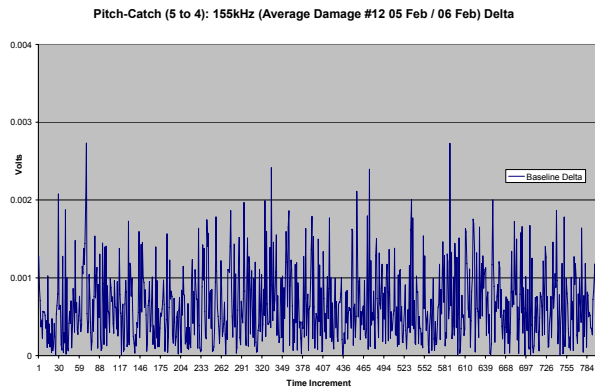
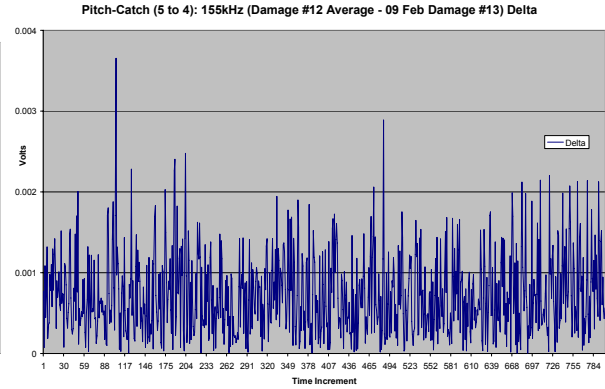
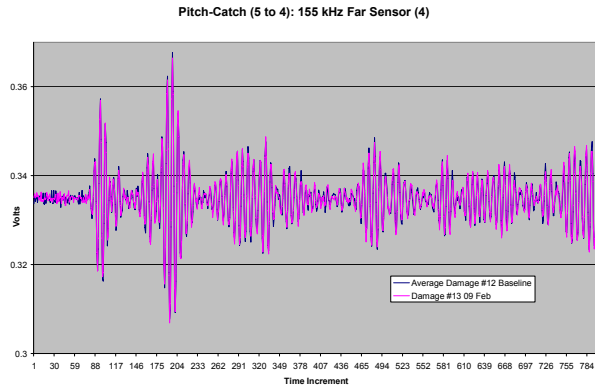
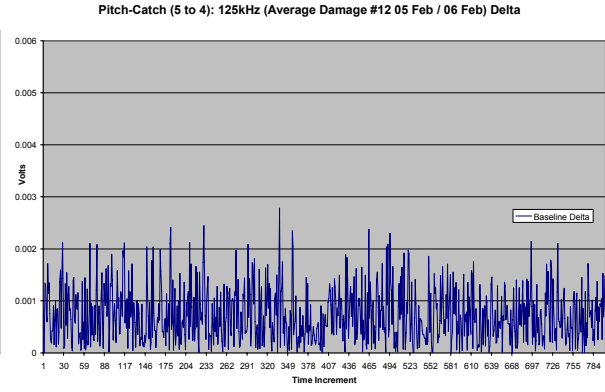
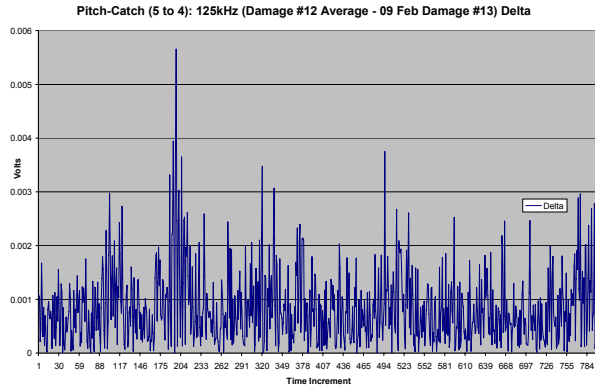

Pitch-Catch (Sensor 5 to 4): 11 Feb 07, Damage 13 – 5mm Gouge, 65mm from Sensor 5, No Offset, Damage 12 Baseline

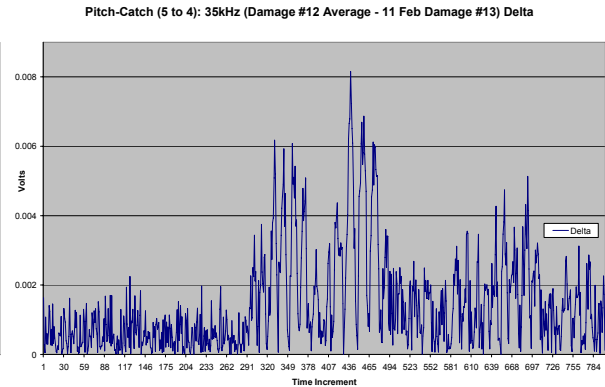
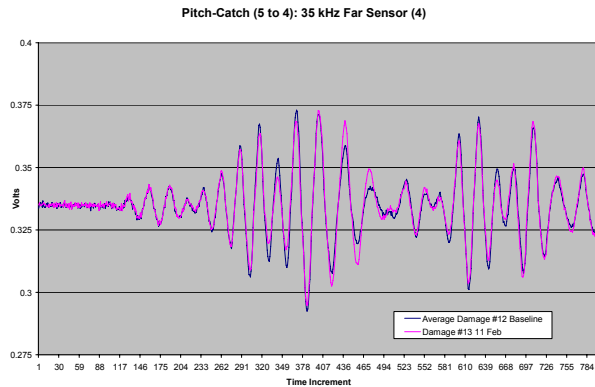

Pitch-Catch (5 to 4): 35kHz (Average Damage #12 05 Feb / 06 Feb) Delta

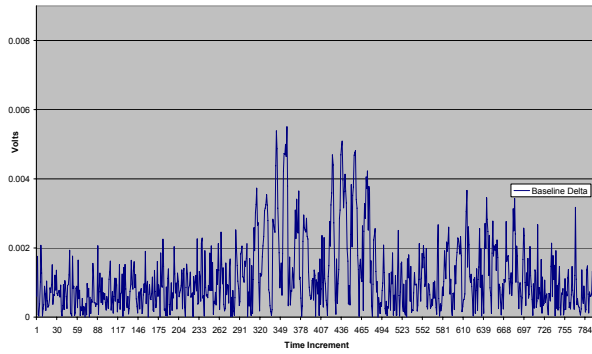

Pitch-Catch (5 to 4): 65 kHz Far Sensor (4)

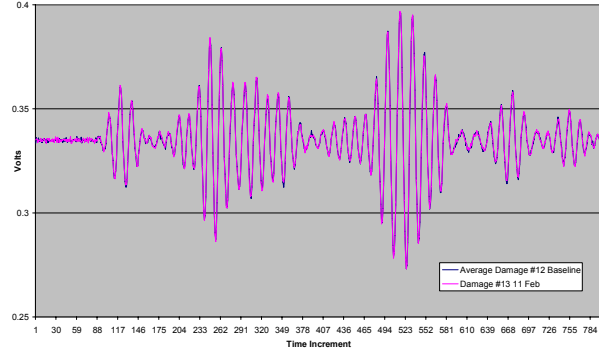

Pitch-Catch (5 to 4): 65kHz (Damage #12 Average - 11 Feb Damage #13) Delta

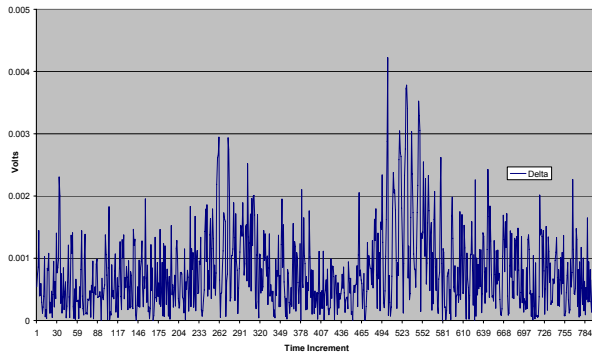

Pitch-Catch (5 to 4): 65kHz (Average Damage #12 05 Feb / 06 Feb) Delta

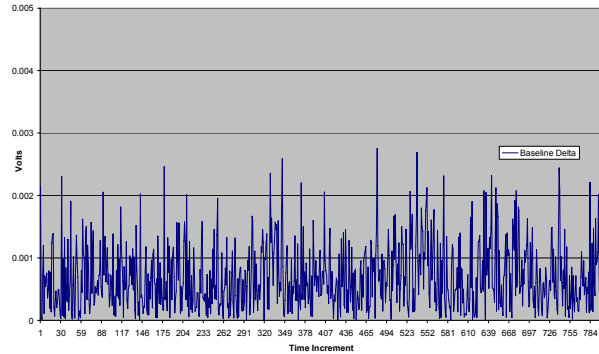

Pitch-Catch (5 to 4): 95 kHz Far Sensor (4)

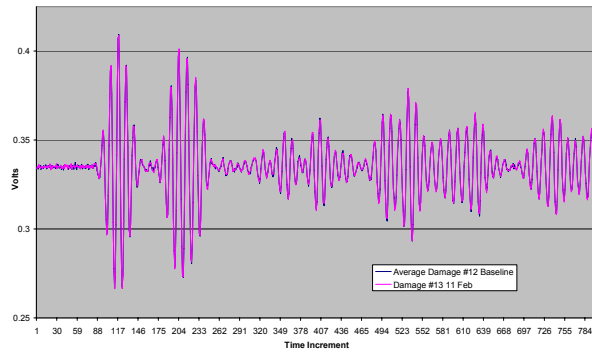

Pitch-Catch (5 to 4): 95kHz (Damage #12 Average - 11 Feb Damage #13) Delta

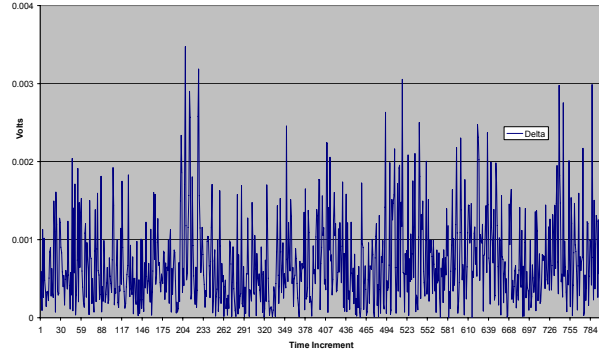

Pitch-Catch (5 to 4): 95kHz (Average Damage #12 05 Feb / 06 Feb) Delta

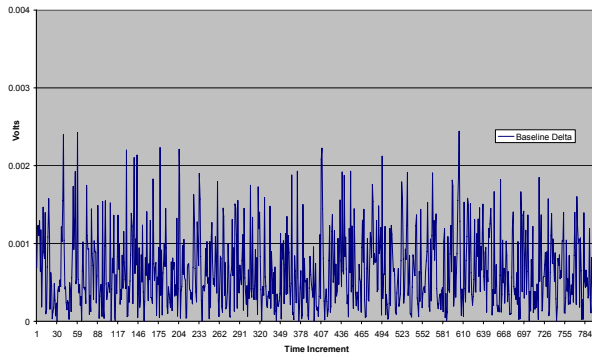

Pitch-Catch (5 to 4): 125 kHz Far Sensor (4)

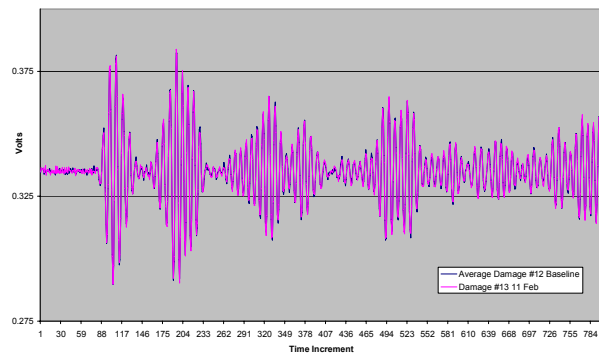

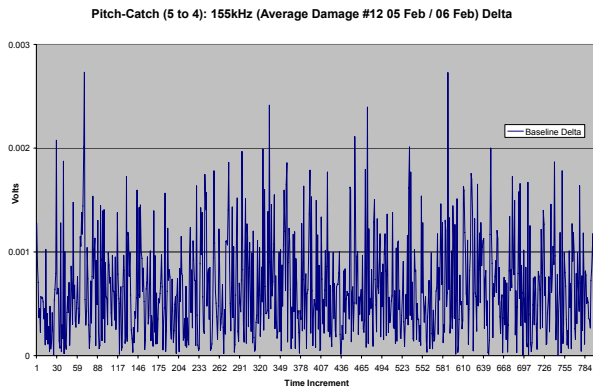
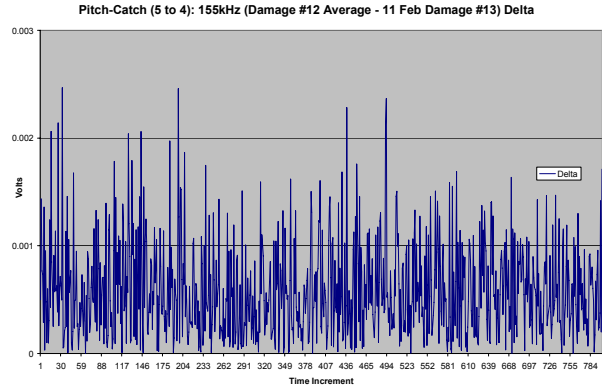
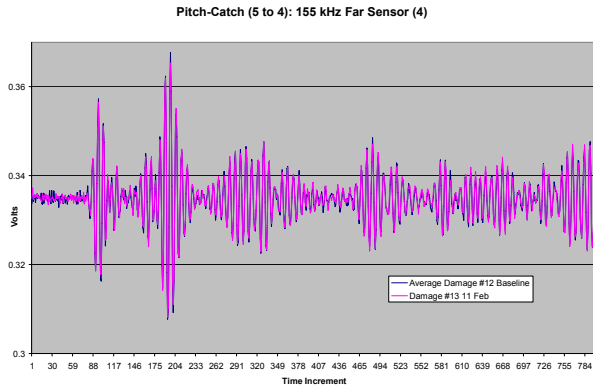
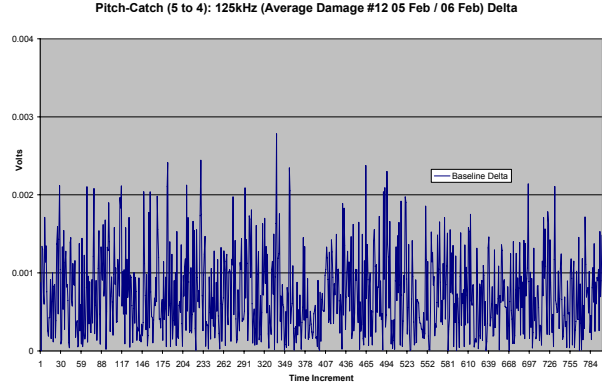
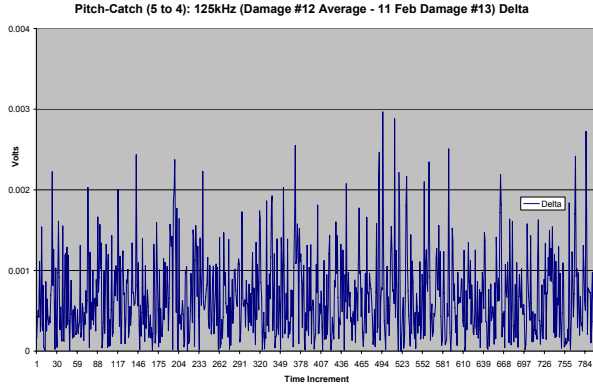

Pitch-Catch (Sensor 5 to 4): 12 Feb 07, Damage 13 – 5mm Gouge, 65mm from Sensor 5, No Offset, Damage 12 Baseline

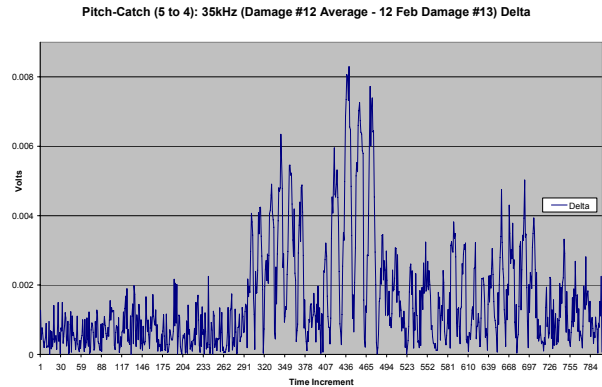
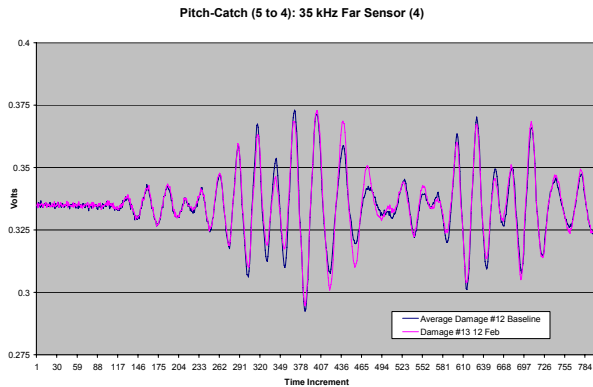

Pitch-Catch (5 to 4): 35kHz (Average Damage #12 05 Feb / 06 Feb) Delta

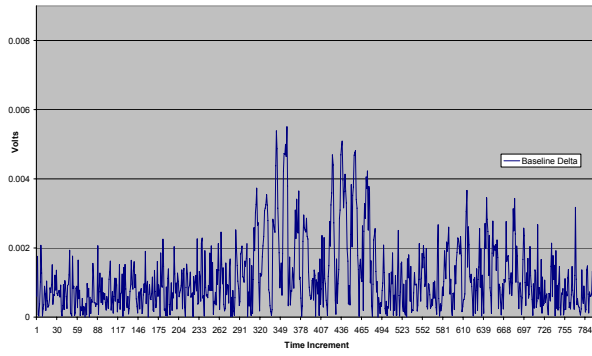

Pitch-Catch (5 to 4): 65 kHz Far Sensor (4)

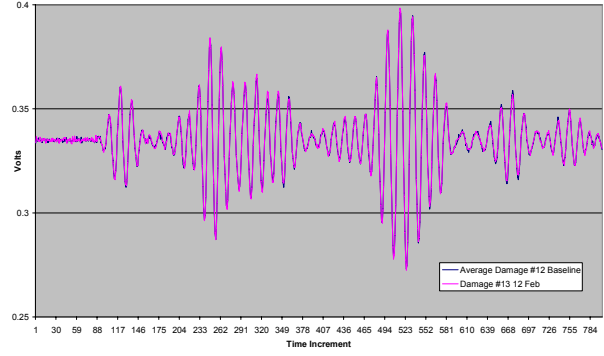

Pitch-Catch (5 to 4): 65kHz (Damage #12 Average - 12 Feb Damage #13) Delta

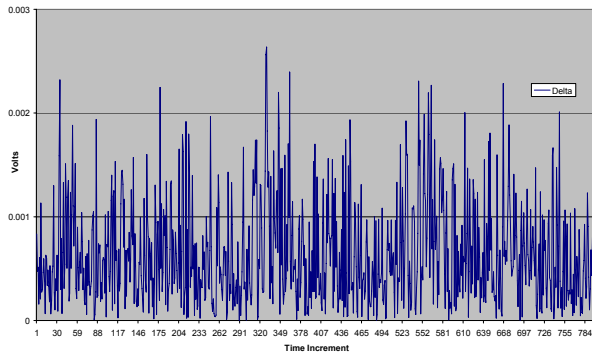

Pitch-Catch (5 to 4): 65kHz (Average Damage #12 05 Feb / 06 Feb) Delta

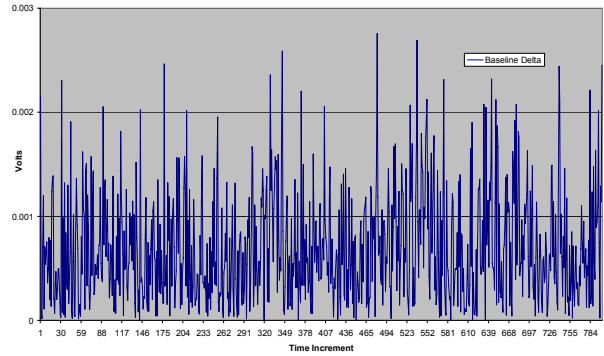

Pitch-Catch (5 to 4): 95 kHz Far Sensor (4)

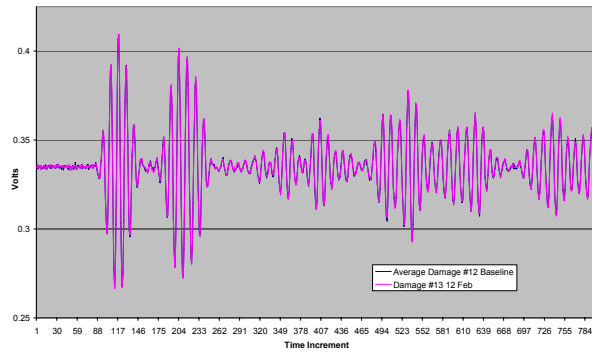

Pitch-Catch (5 to 4): 95kHz (Damage #12 Average - 12 Feb Damage #13) Delta

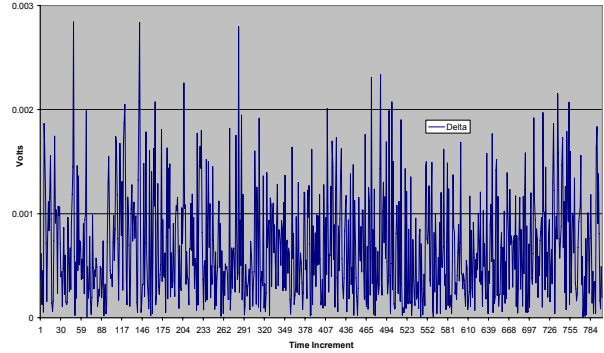

Pitch-Catch (5 to 4): 95kHz (Average Damage #12 05 Feb / 06 Feb) Delta

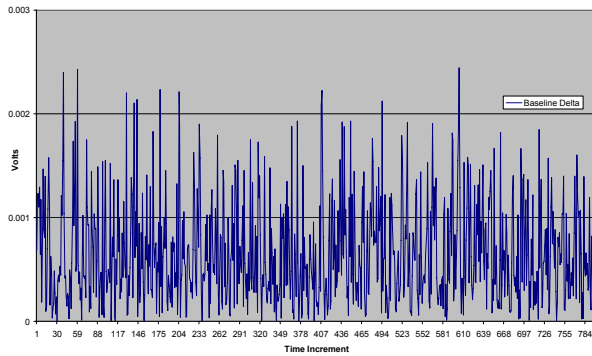

Pitch-Catch (5 to 4): 125 kHz Far Sensor (4)

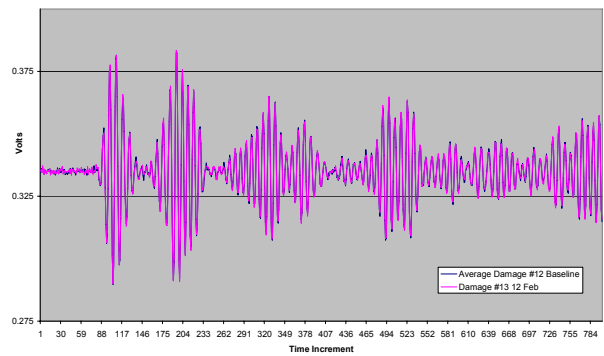

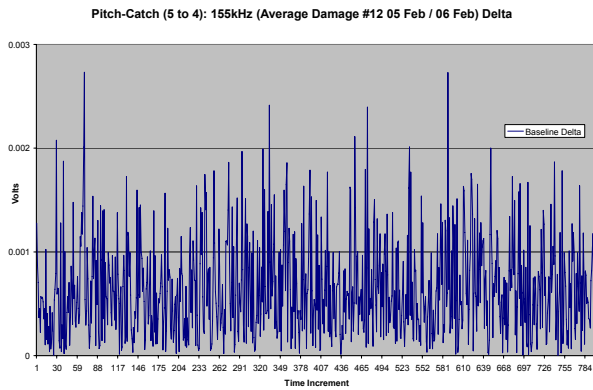
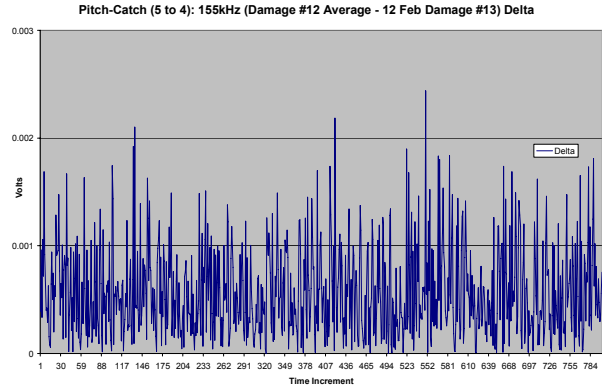
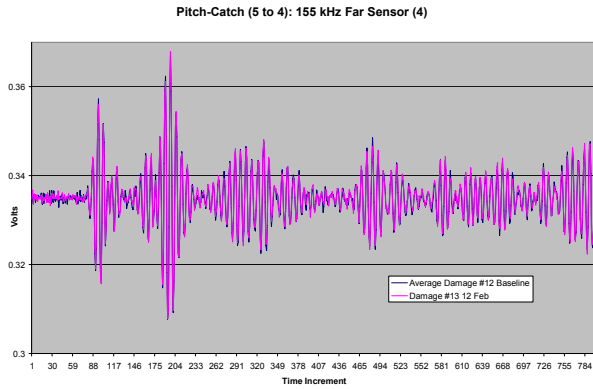
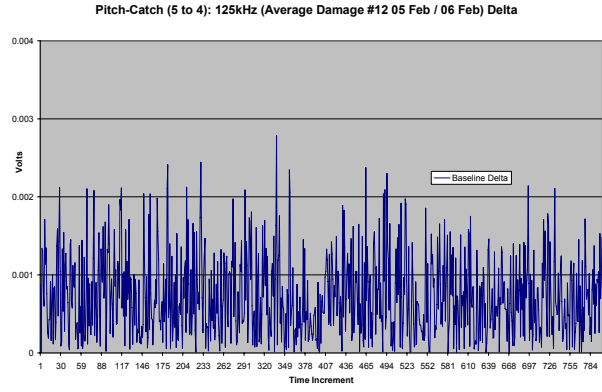
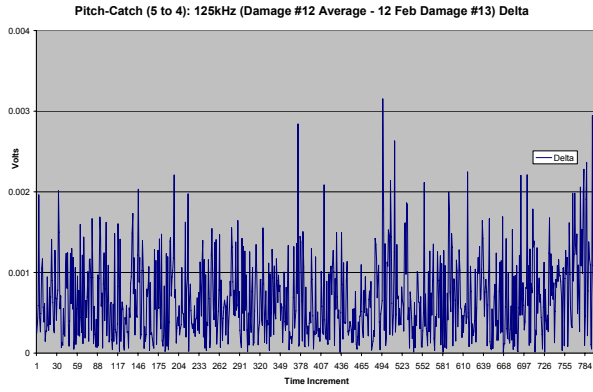

Pitch-Catch (Sensor 5 to 4): 12 Feb 07, Damage 14 – 2mm Cut from Center Hole
Damage 13 Baseline

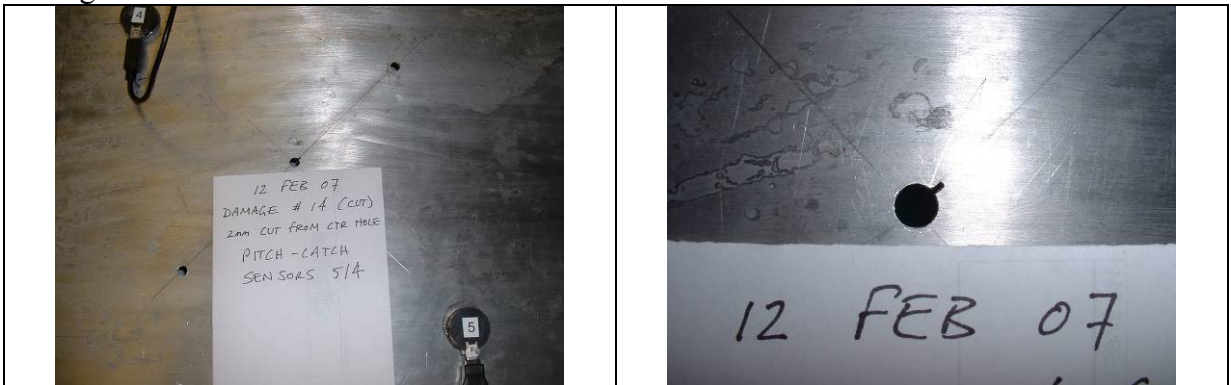

Pitch-Catch (5 to 4): 35 kHz Far Sensor (4)

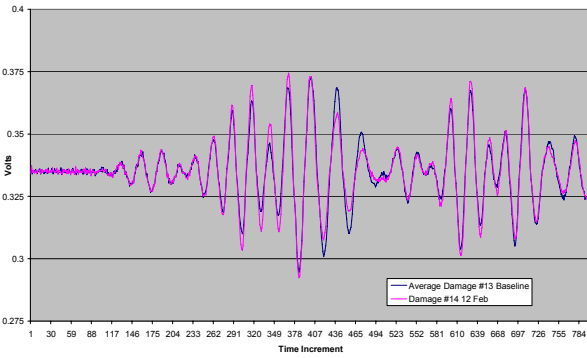

Pitch-Catch (5 to 4): 35kHz (Damage #13 Average - 12 Feb Damage #14) Delta

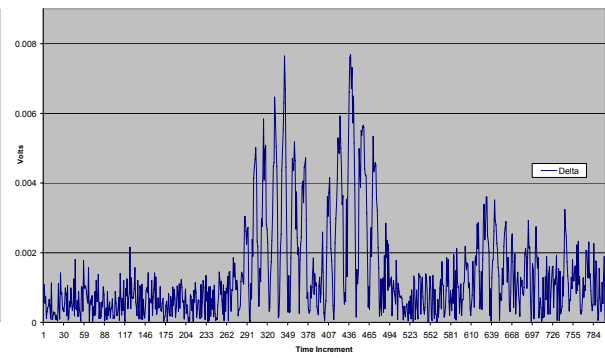

Pitch-Catch (5 to 4): 35kHz (Average Damage #13 09 Feb / 11 Feb / 12 Feb) Delta

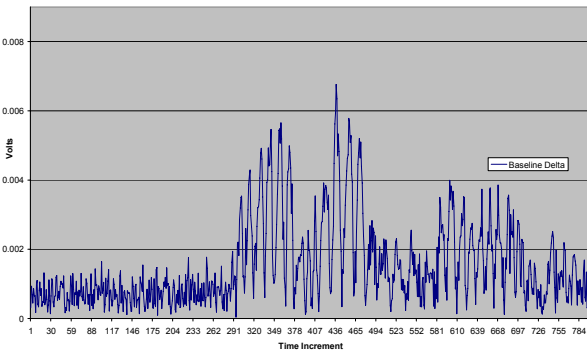

Pitch-Catch (5 to 4): 65 kHz Far Sensor (4)

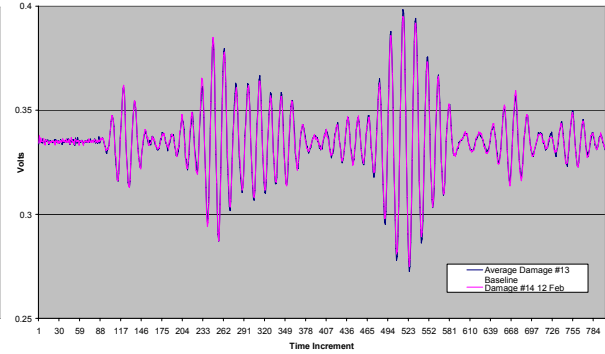

Pitch-Catch (5 to 4): 65kHz (Damage #13 Average - 12 Feb Damage #14) Delta

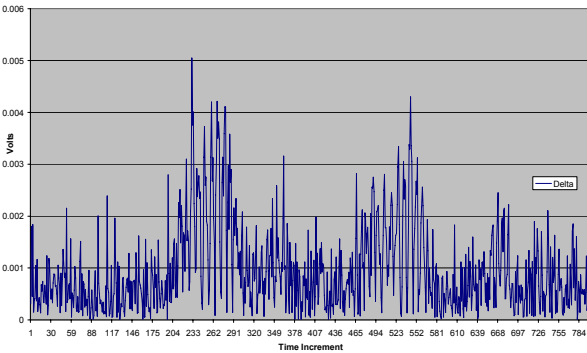

Pitch-Catch (5 to 4): 65kHz (Average Damage #13 09 Feb / 11 Feb / 12 Feb) Delta

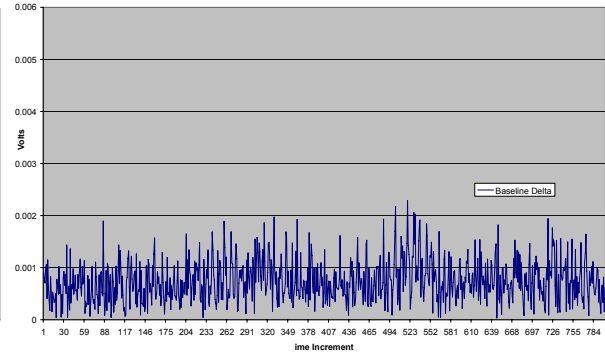

Pitch-Catch (5 to 4): 95 kHz Far Sensor (4)

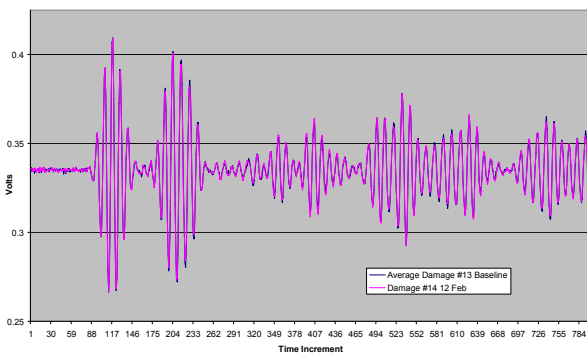

Pitch-Catch (5 to 4): 95kHz (Damage #13 Average - 12 Feb Damage #14) Delta

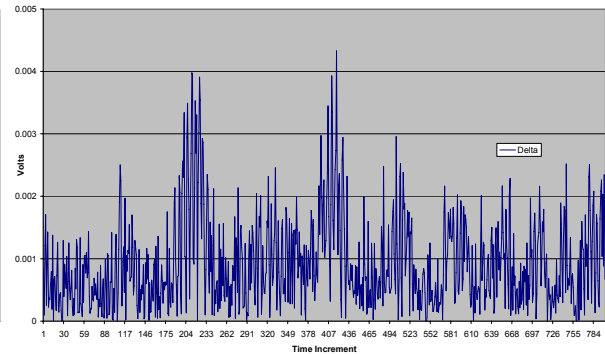

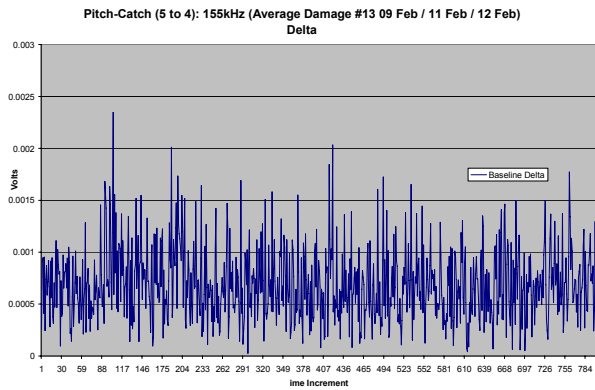
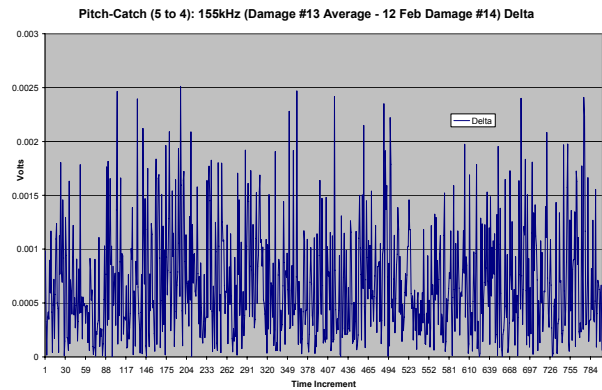
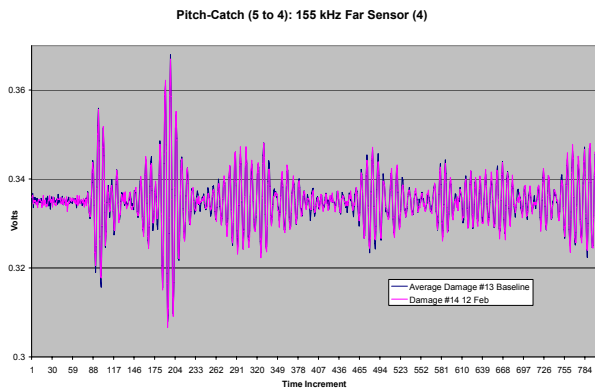
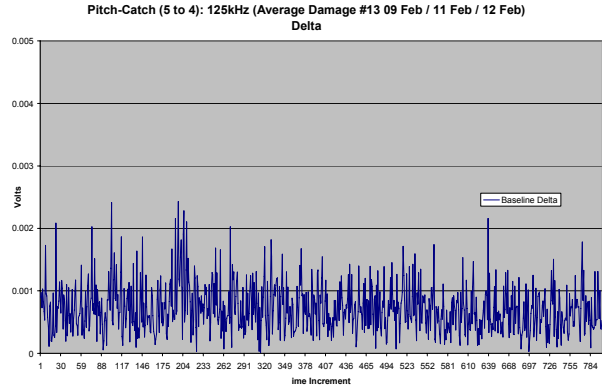
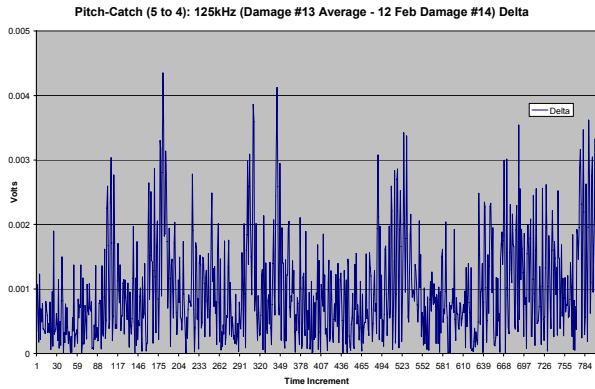
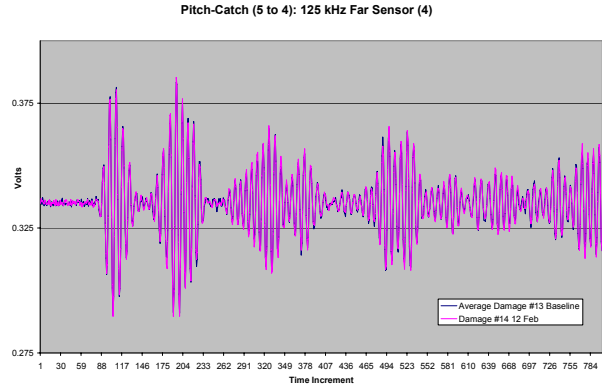
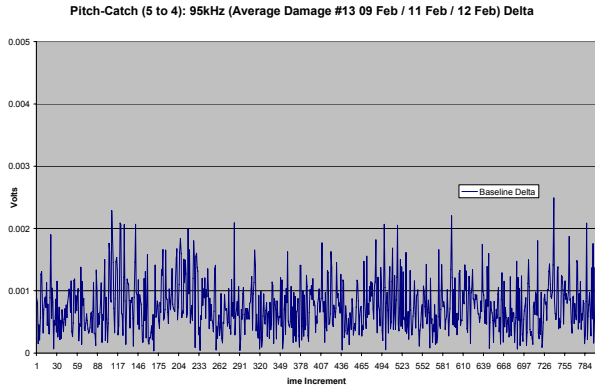

Pitch-Catch (Sensor 5 to 4): 12 Feb 07 Run 2, Damage 14 – 2mm Cut from Center Hole Damage 13 Baseline

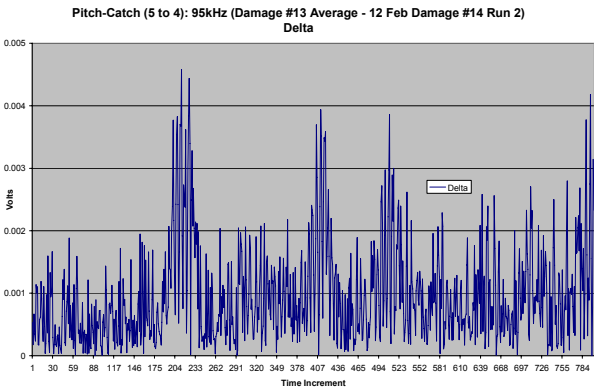
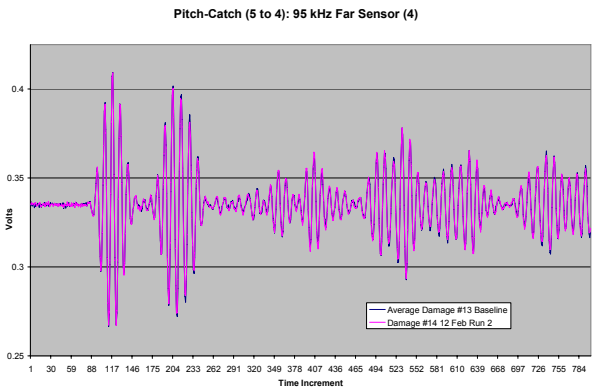
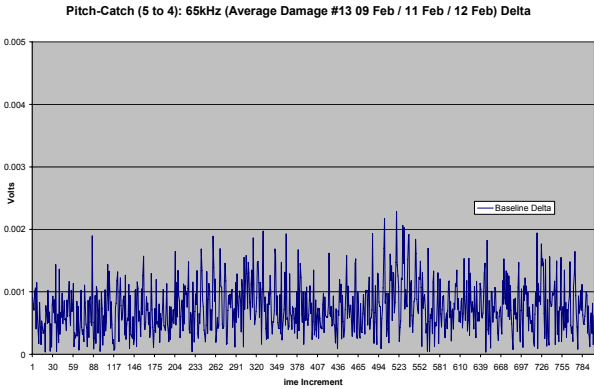
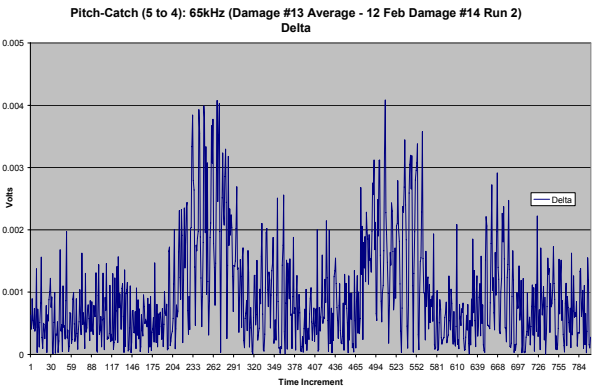
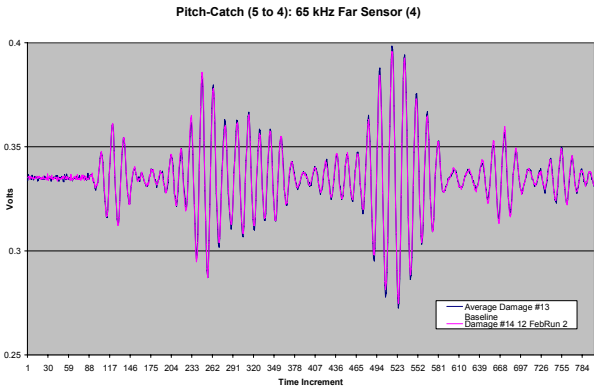
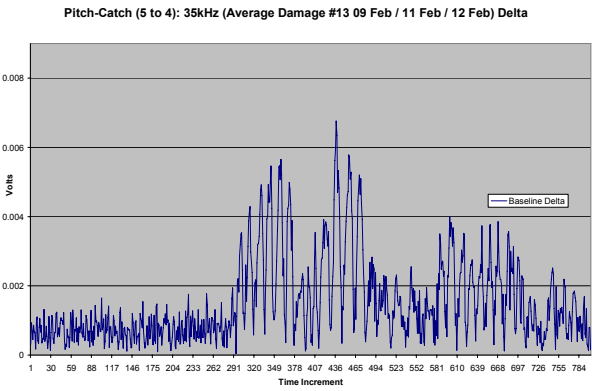
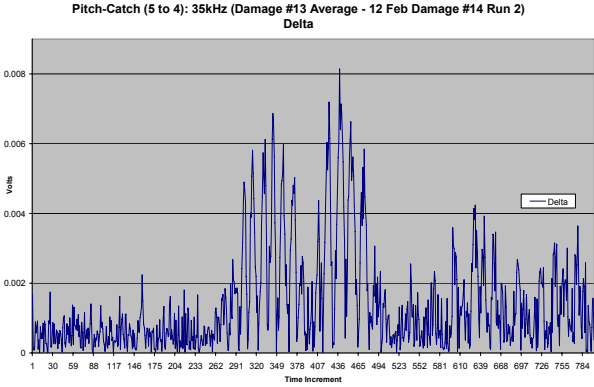
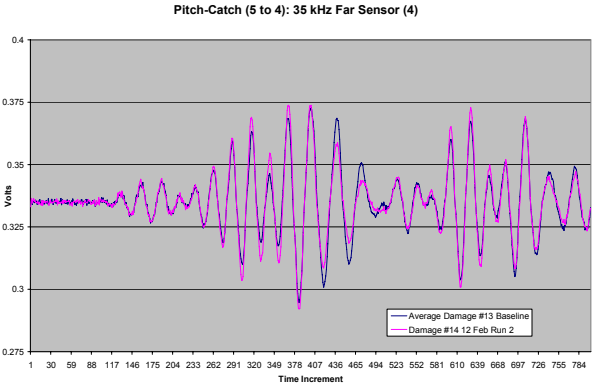

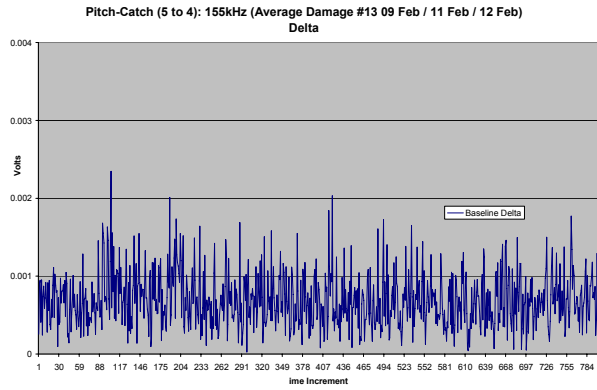
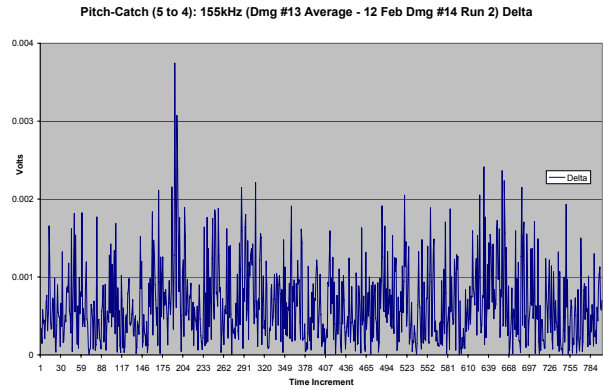
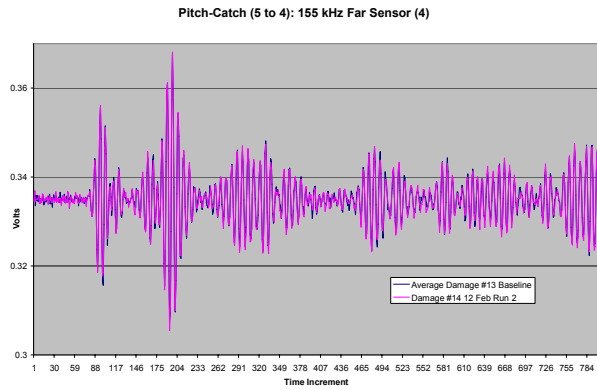
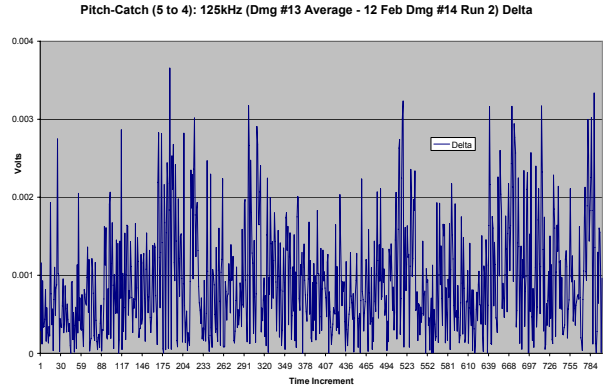
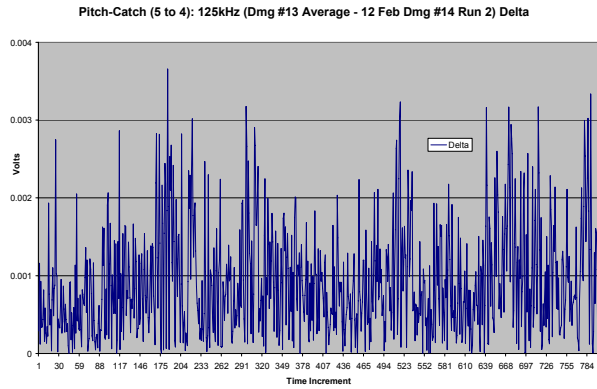
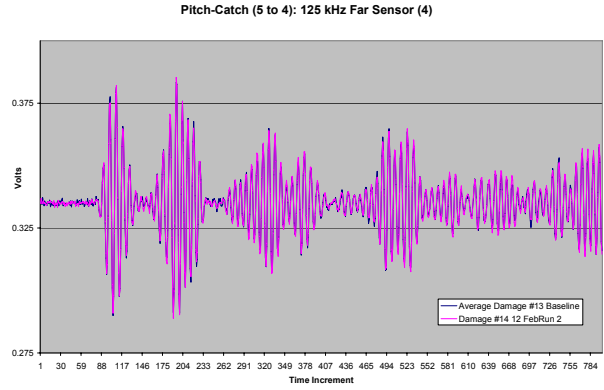
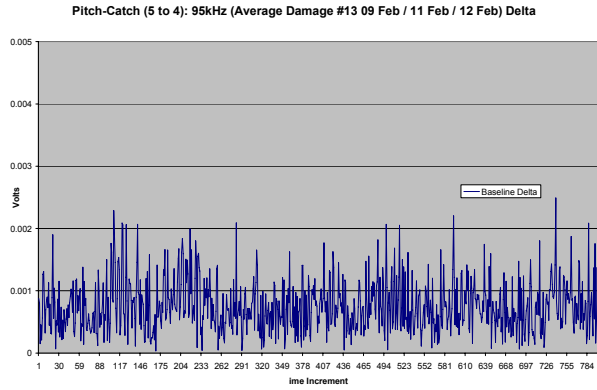

Pitch-Catch (Sensor 5 to 4): 06 Feb 07, Damage 12 w/ Angle, Damage 12 Baseline

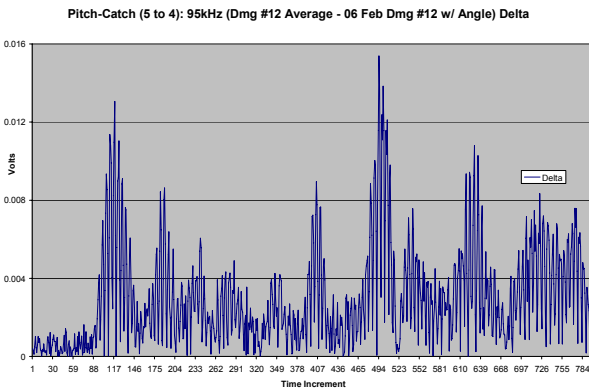
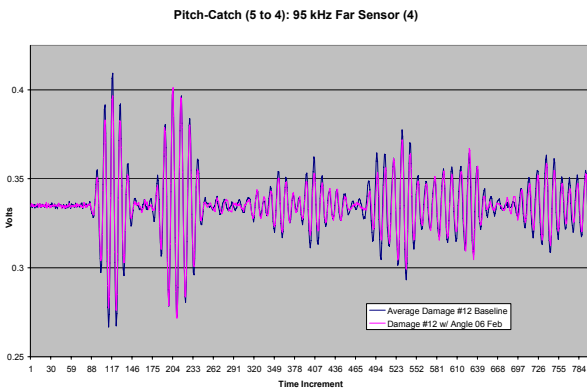
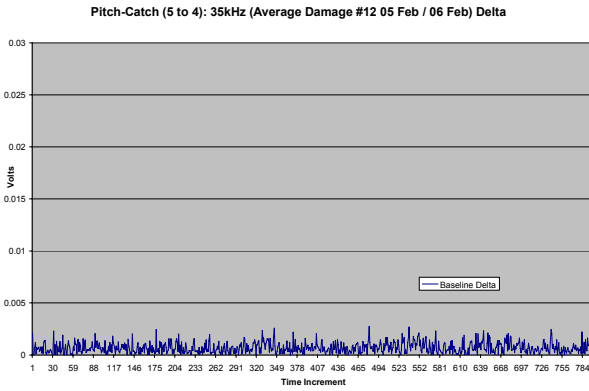
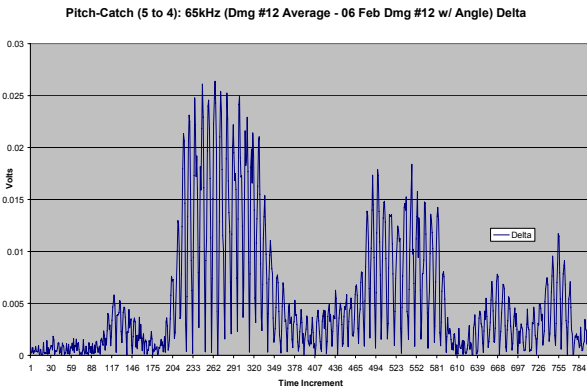
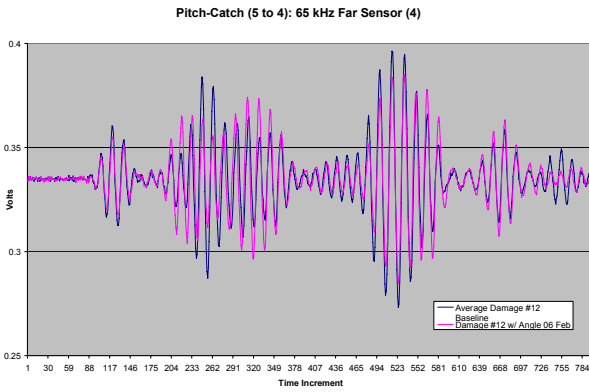
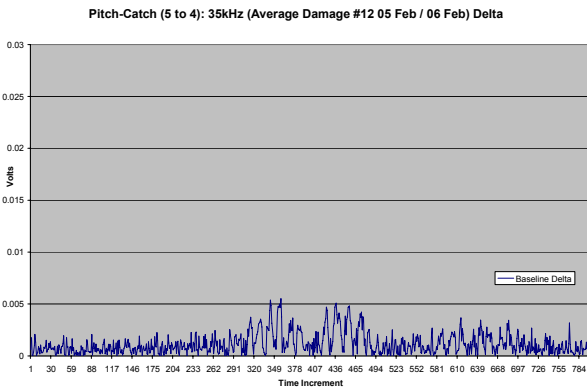
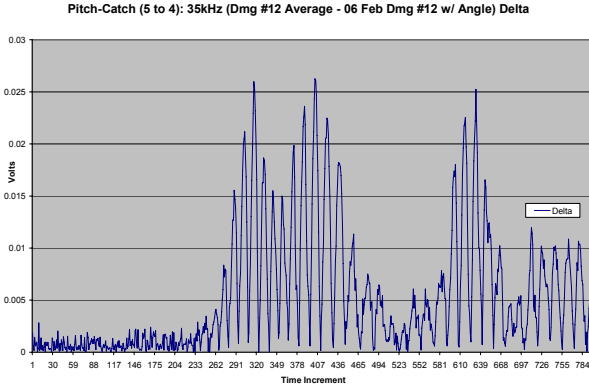
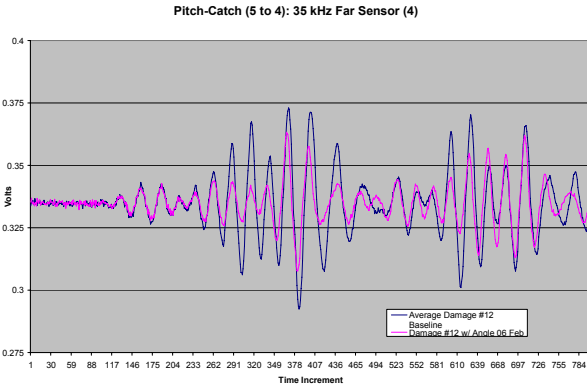

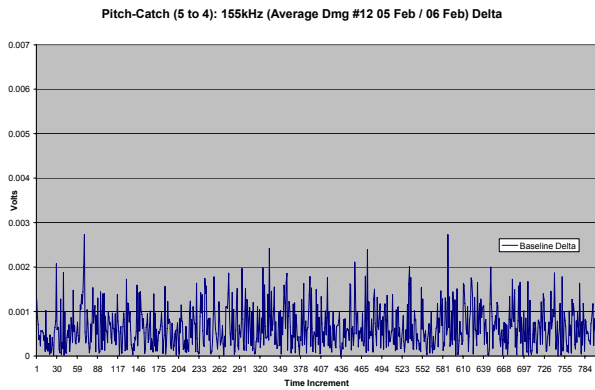
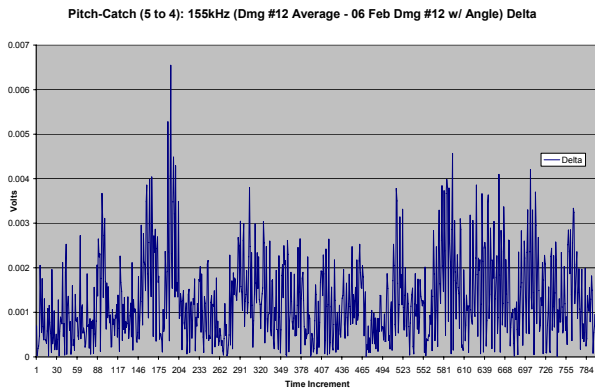
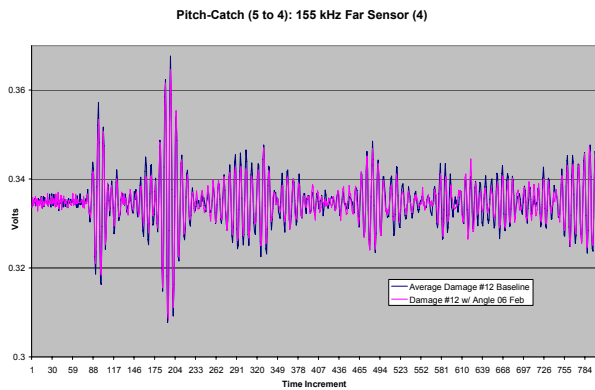
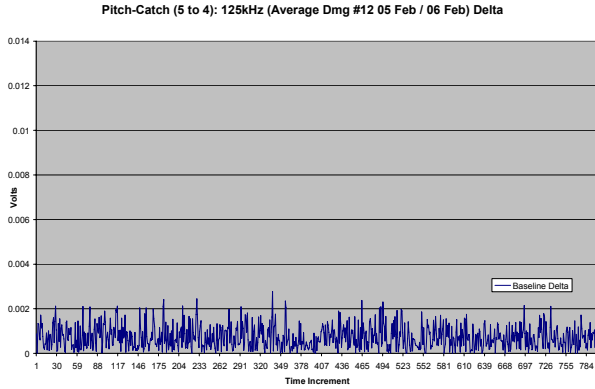
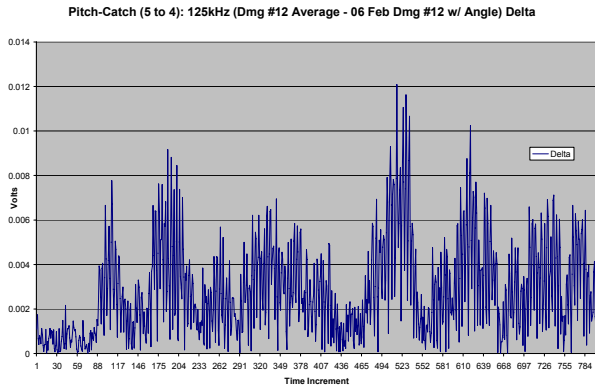
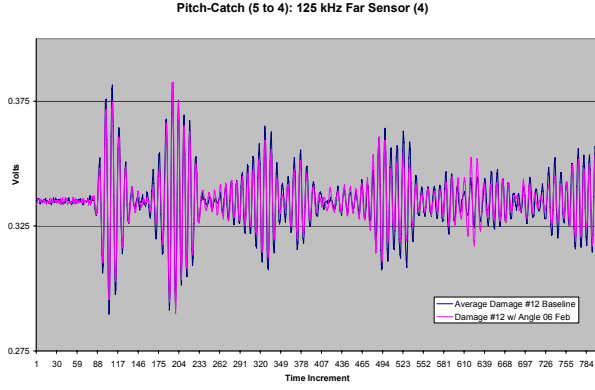
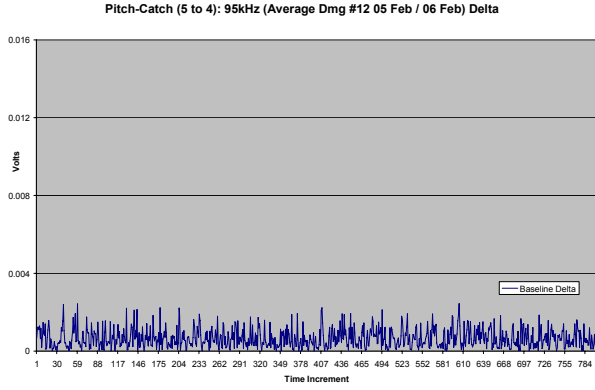

Pitch-Catch (Sensor 5 to 4): 07 Feb 07, Damage 12 w/ Angle, Damage 12 Baseline

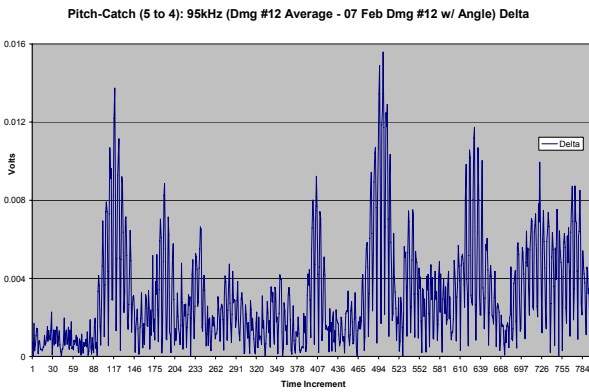
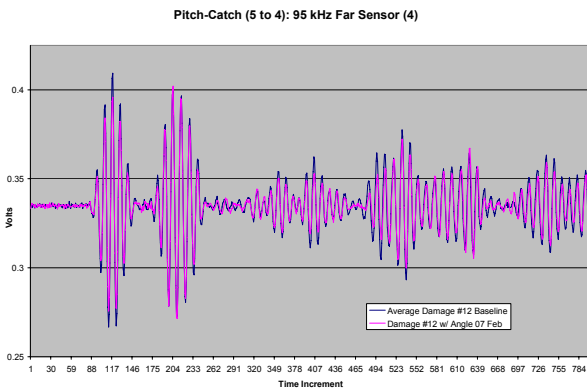
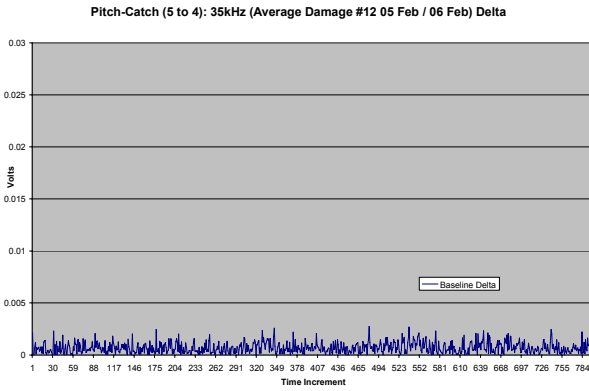
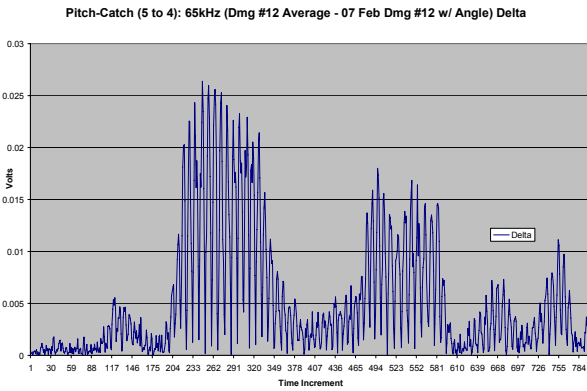
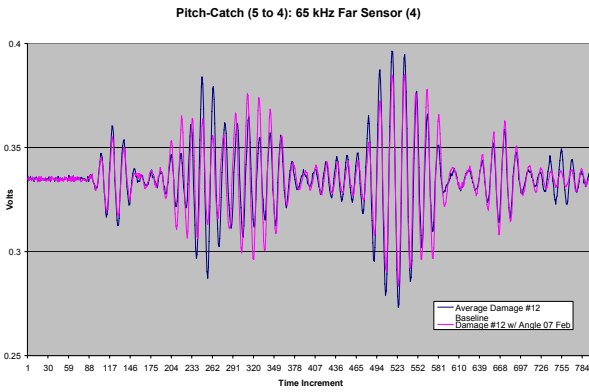
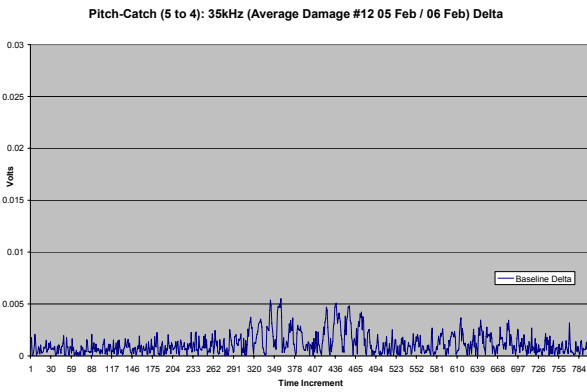
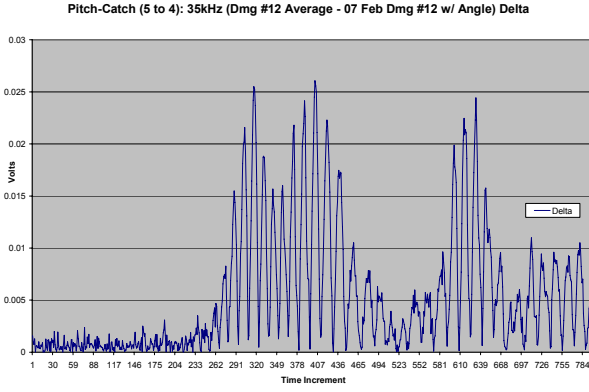
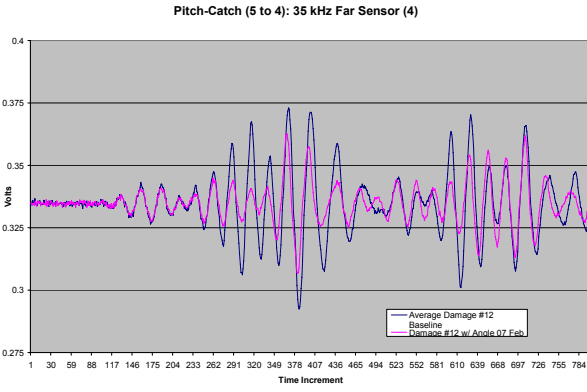

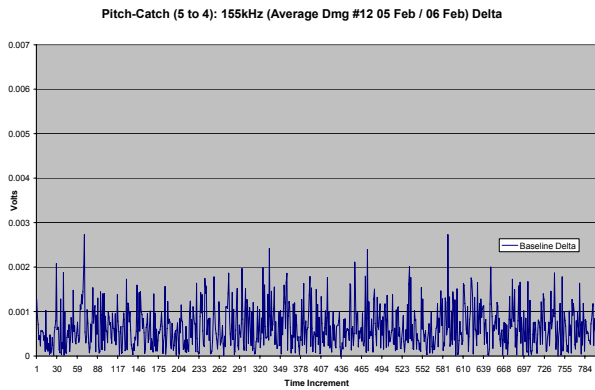
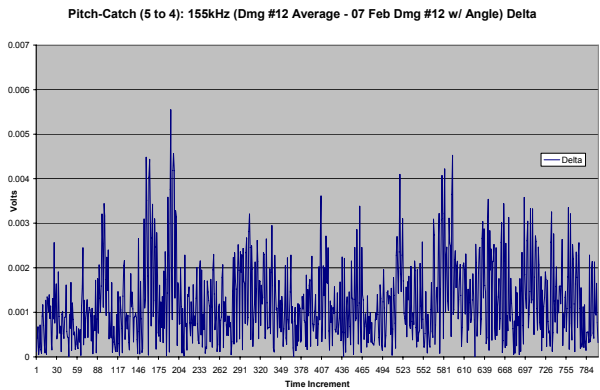
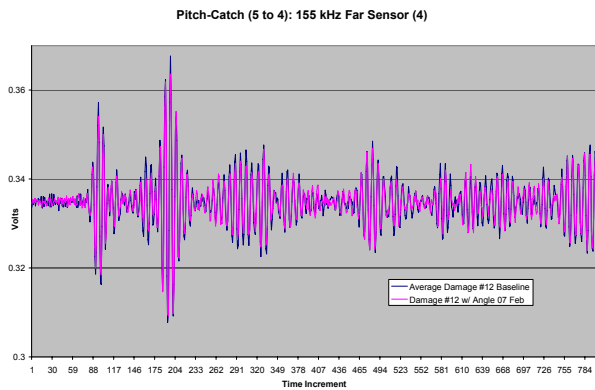
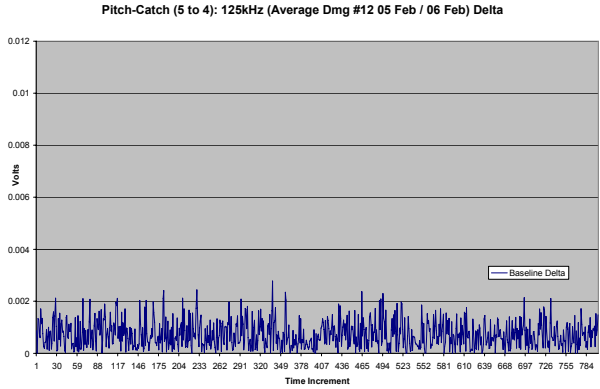
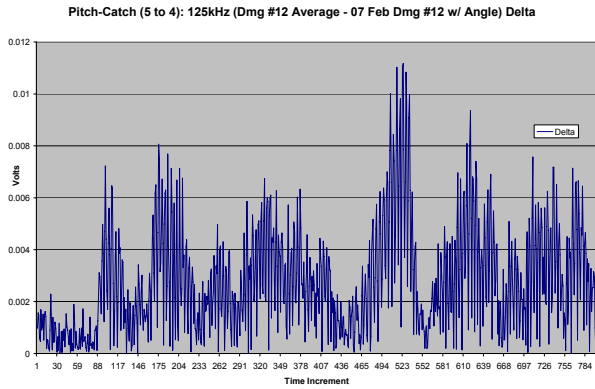
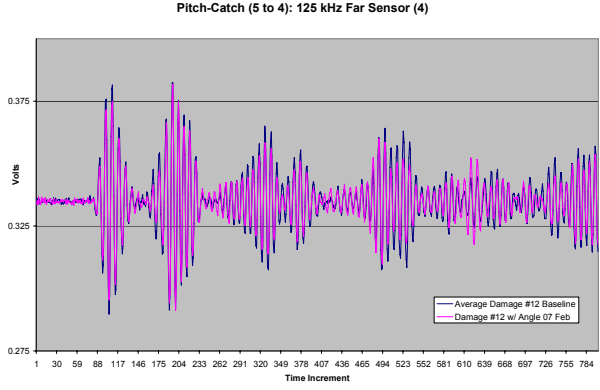
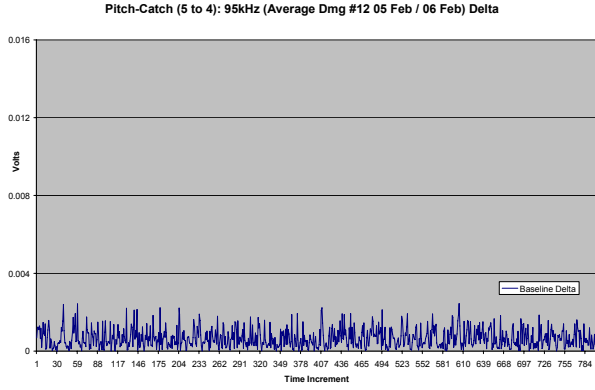

Pitch-Catch (Sensor 5 to 4): 08 Feb 07, Damage 12 w/ Angle, Damage 12 Baseline

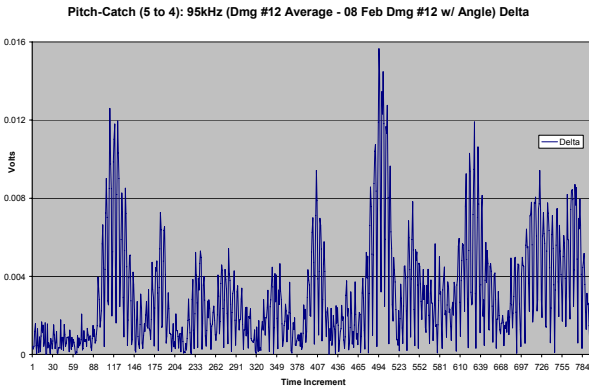
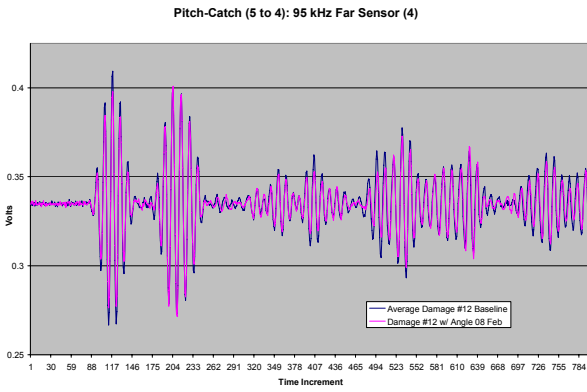
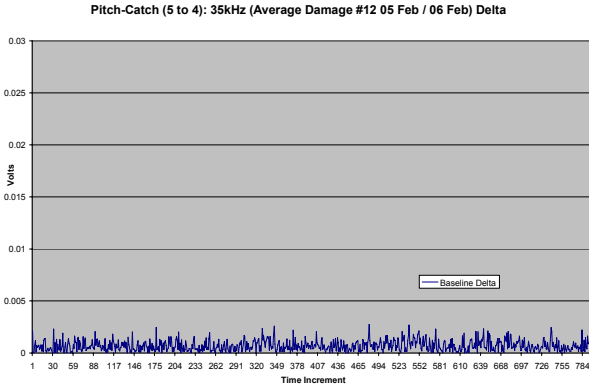
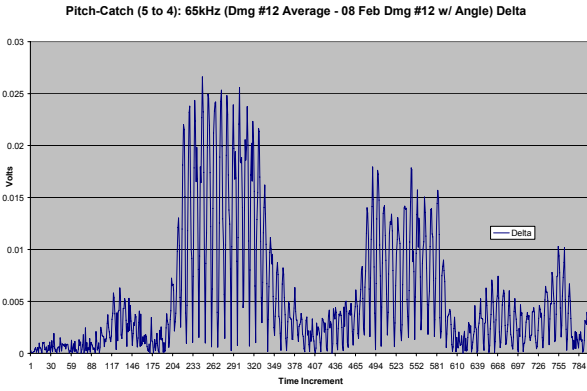
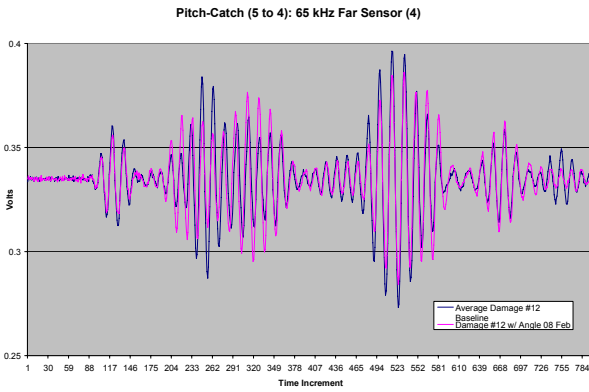
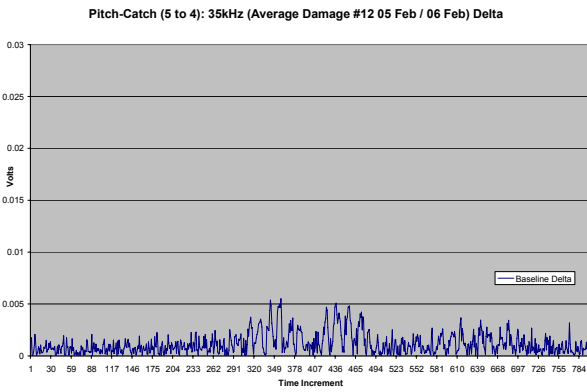
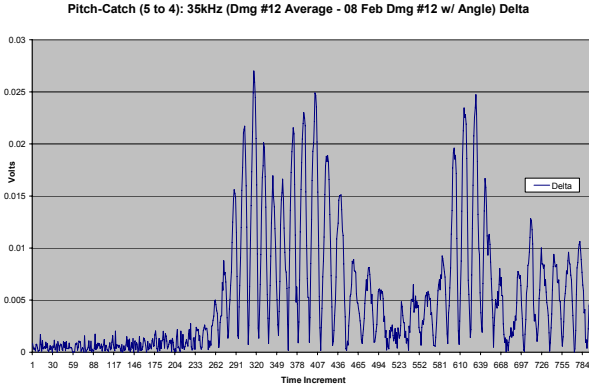
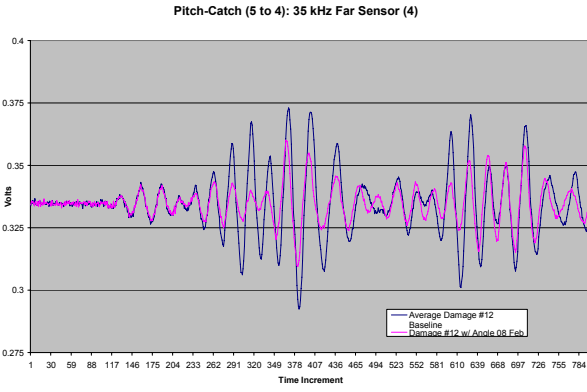

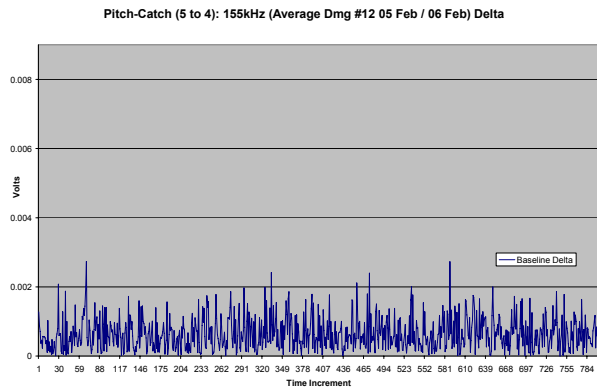
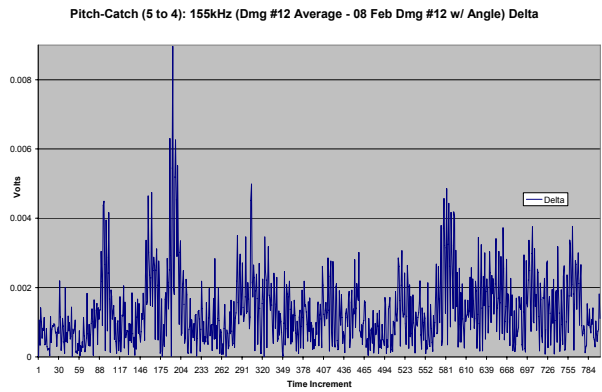
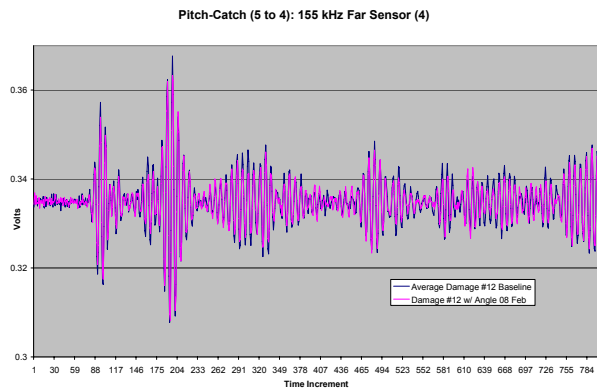
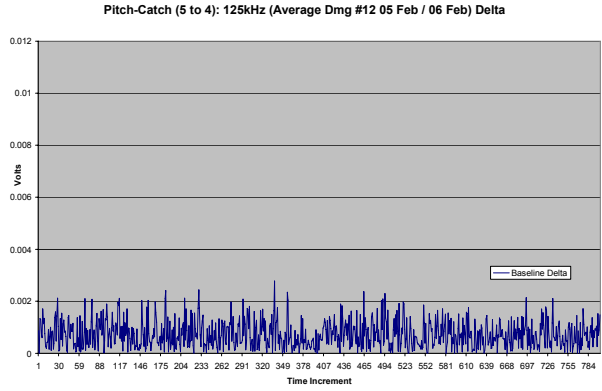
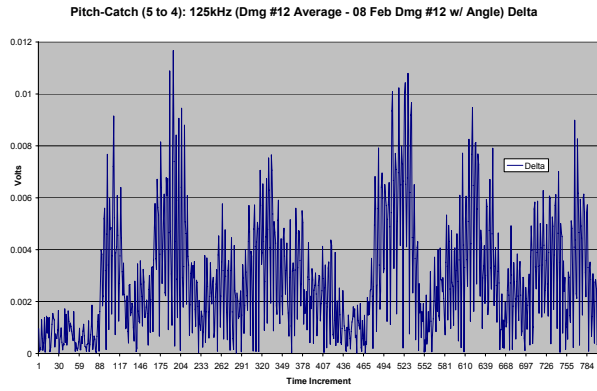
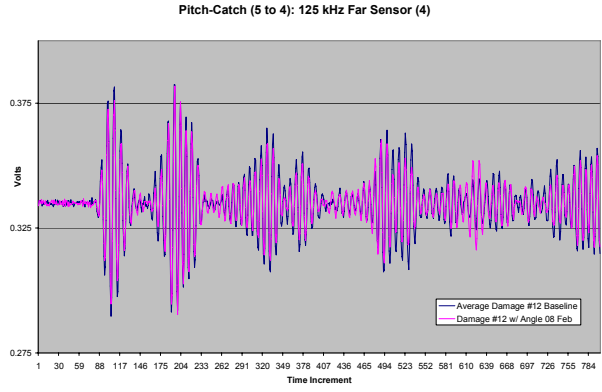
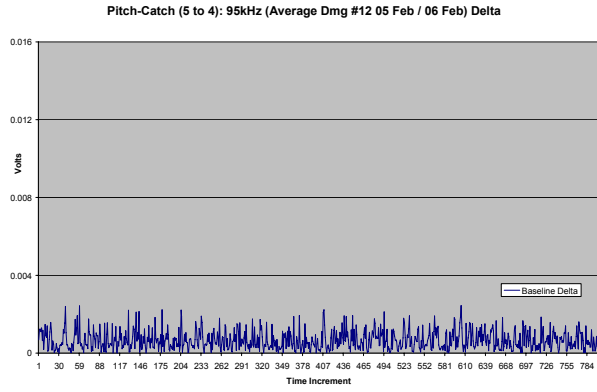

Pitch-Catch (Sensor 5 to 4): 08 Feb 07, Damage 13 w/ Angle, Damage 12 w/ Angle Baseline

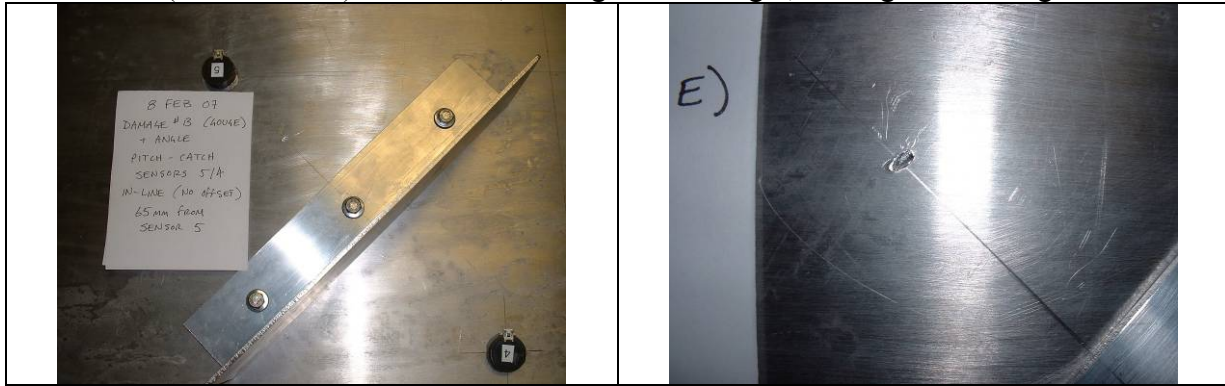

Pitch-Catch (5 to 4): 35 kHz Far Sensor (4)

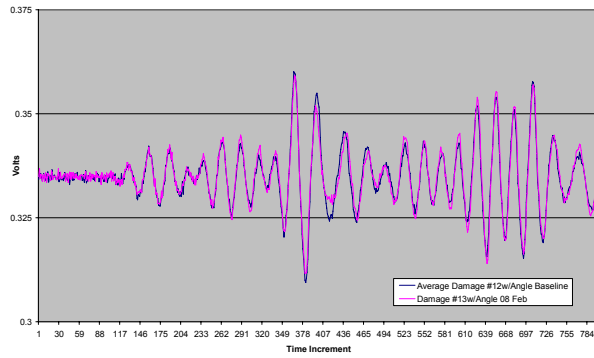

Pitch-Catch (5 to 4): 35kHz (Damage #12 w/ Angle Average - 08 Feb Damage #13 w/ Angle) Delta

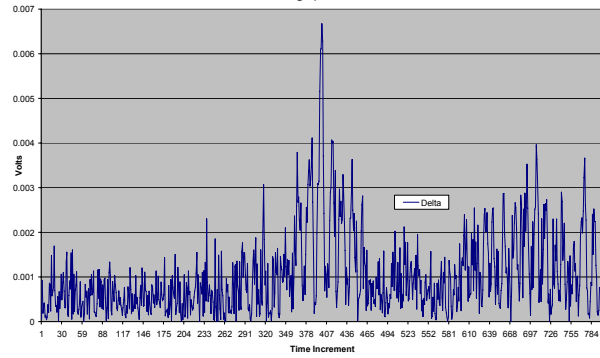

Pitch-Catch (5 to 4): 35kHz (Average Damage #12 w/ Angle 08 Feb / 09 Feb / 10 Feb) Delta

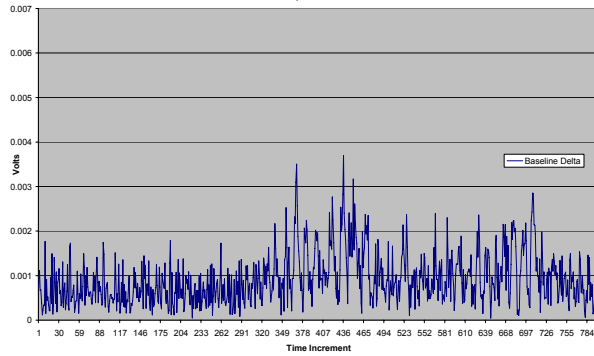

Pitch-Catch (5 to 4): 65 kHz Far Sensor (4)

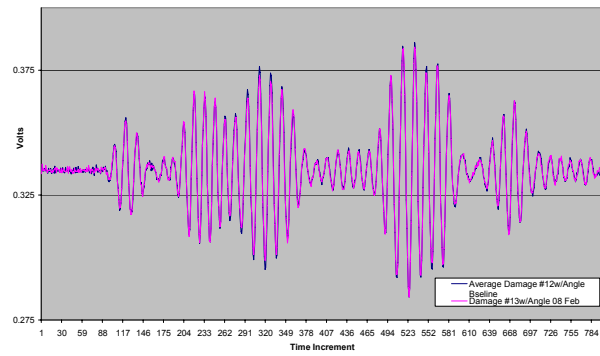

Pitch-Catch (5 to 4): 65kHz (Damage #12 w/ Angle Average - 08 Feb Damage #13 w/ Angle) Delta

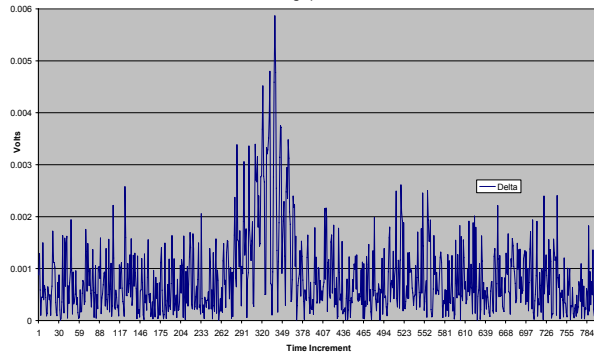

Pitch-Catch (5 to 4): 65kHz (Average Damage #12 w/ Angle 08 Feb / 09 Feb / 10 Feb) Delta

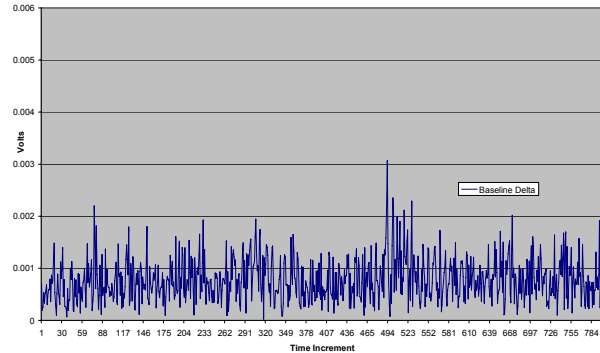

Pitch-Catch (5 to 4): 95 kHz Far Sensor (4)

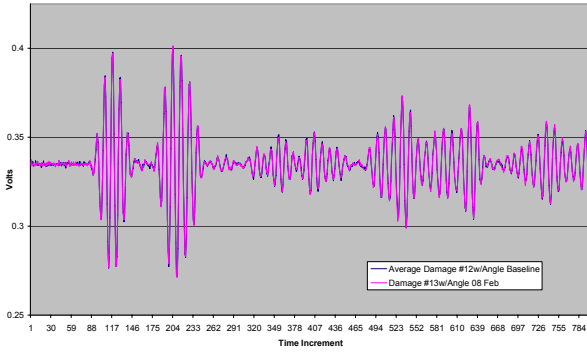

Pitch-Catch (5 to 4): 95kHz (Damage #12 w/ Angle Average - 08 Feb Damage #13 w/ Angle) Delta

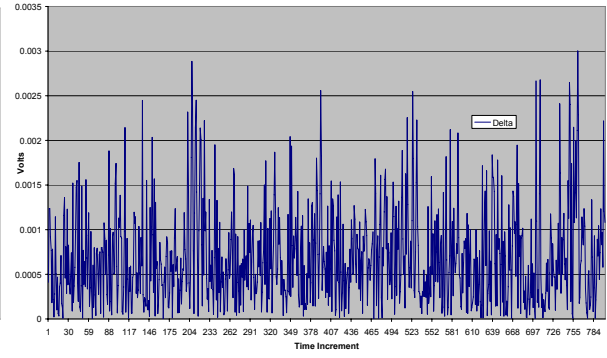

Pitch-Catch (5 to 4): 95kHz (Average Damage #12 w/ Angle 08 Feb / 09 Feb / 10 Feb) Delta

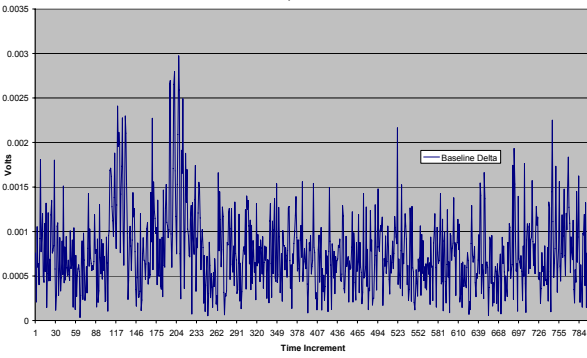

Pitch-Catch (5 to 4): 125 kHz Far Sensor (4)

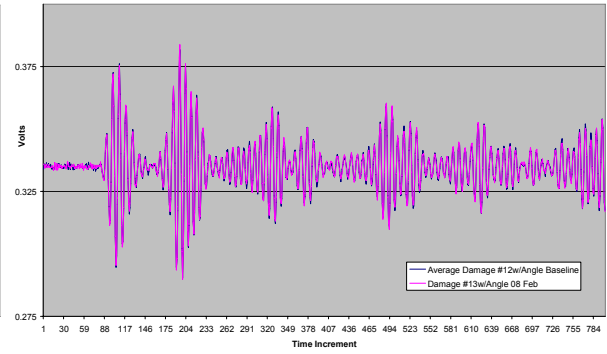

Pitch-Catch (5 to 4): 125kHz (Damage #12 w/ Angle Average - 08 Feb Damage #13 w/ Angle) Delta

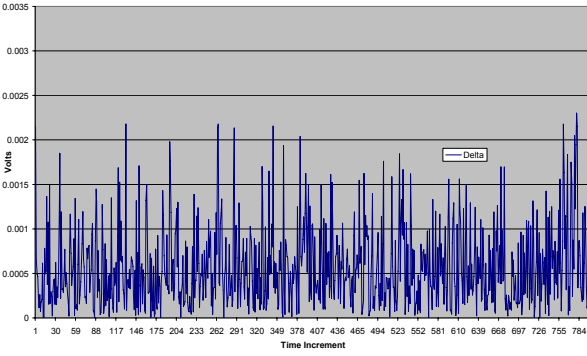

Pitch-Catch (5 to 4): 125kHz (Average Damage #12 w/ Angle 08 Feb / 09 Feb / 10 Feb) Delta

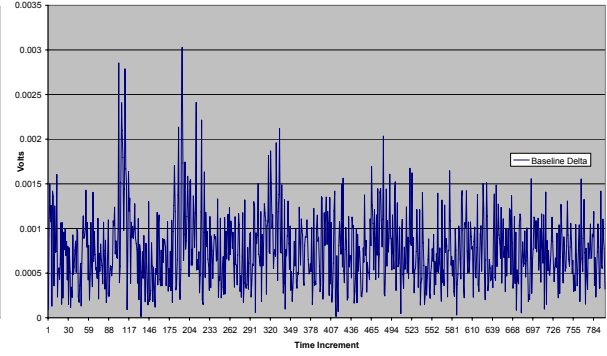

Pitch-Catch (5 to 4): 155 kHz Far Sensor (4)

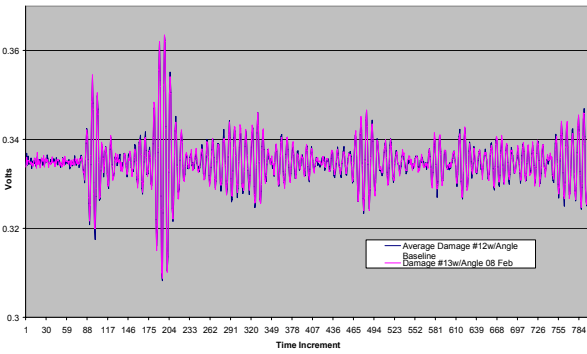

Pitch-Catch (5 to 4): 155kHz (Damage #12 w/ Angle Average - 08 Feb Damage #13 w/ Angle) Delta

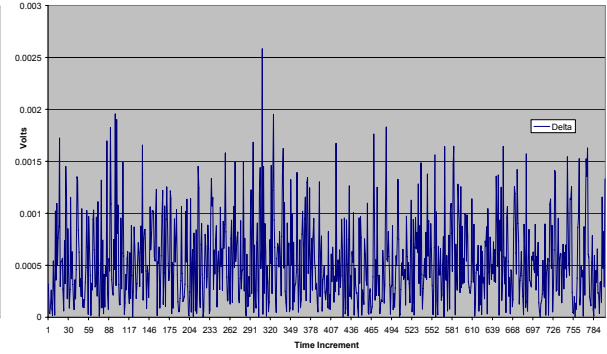

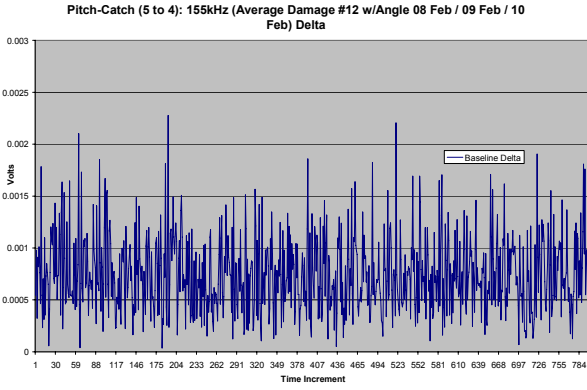

Pitch-Catch (Sensor 5 to 4): 08 Feb 07 Run 2, Damage 13 w/ Angle Damage 12 w/ Angle Baseline

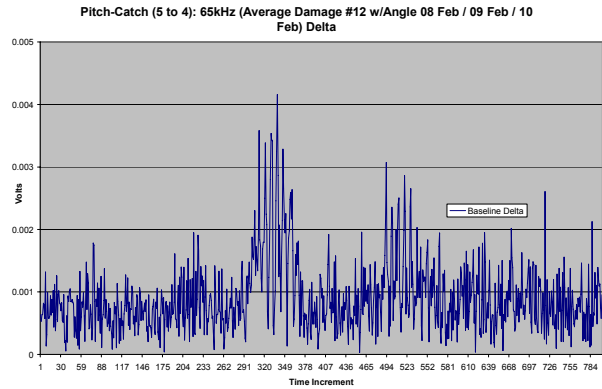
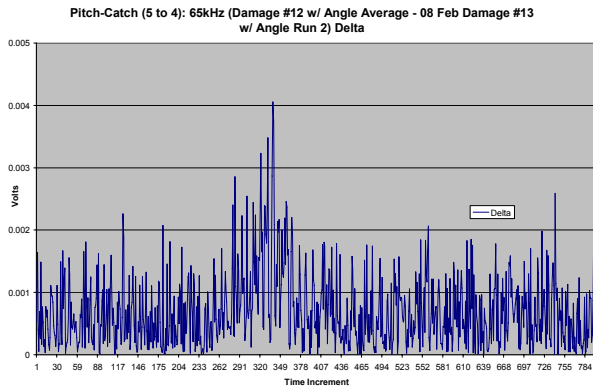
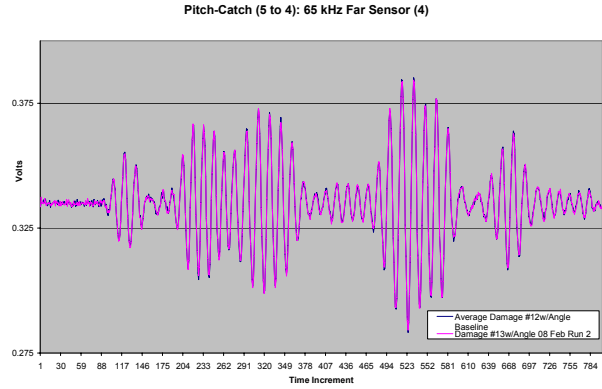
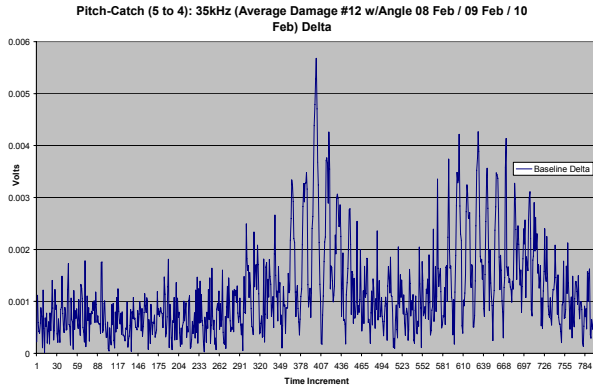
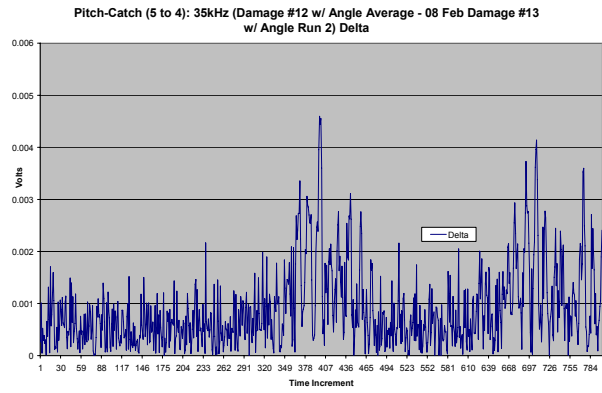
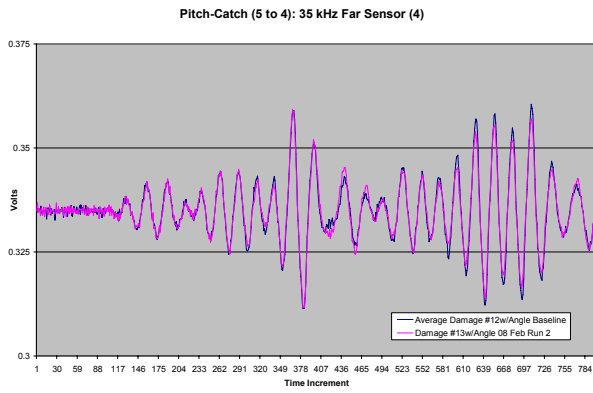

Pitch-Catch (5 to 4): 95 kHz Far Sensor (4)

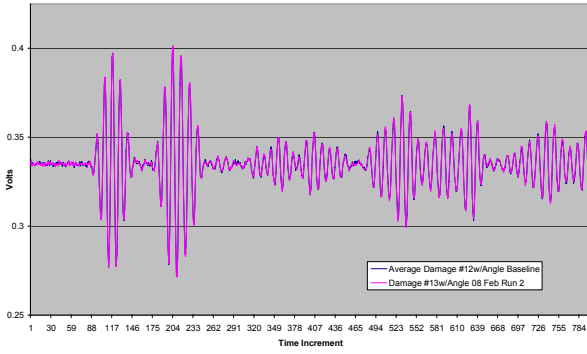

Pitch-Catch (5 to 4): 95kHz (Damage #12 w/ Angle Average - 08 Feb Damage #13 w/ Angle Run 2) Delta

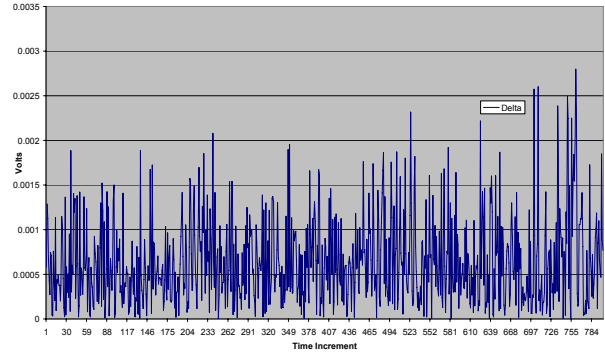

Pitch-Catch (5 to 4): 95kHz (Average Damage #12 w/ Angle 08 Feb / 09 Feb / 10 Feb) Delta

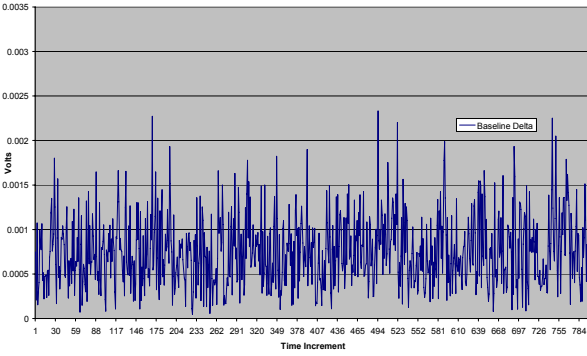

Pitch-Catch (5 to 4): 125 kHz Far Sensor (4)

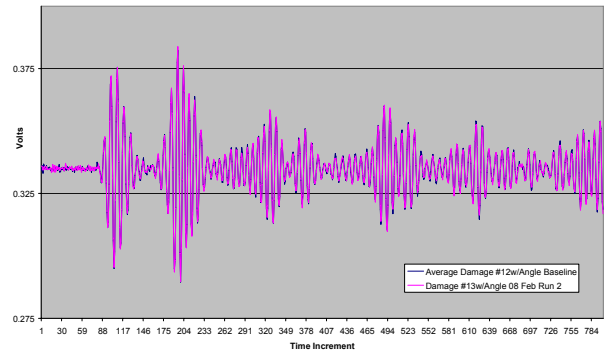

Pitch-Catch (5 to 4): 125kHz (Damage #12 w/ Angle Average - 08 Feb Damage #13 w/ Angle Run 2) Delta

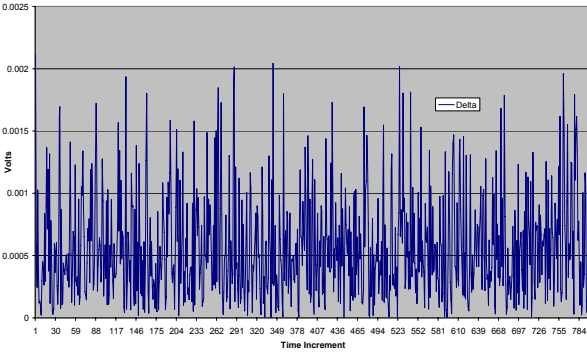

Pitch-Catch (5 to 4): 125kHz (Average Damage #12 w/ Angle 08 Feb / 09 Feb / 10 Feb) Delta

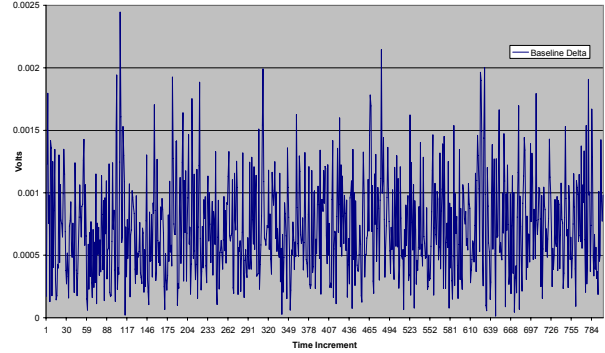

Pitch-Catch (5 to 4): 155 kHz Far Sensor (4)

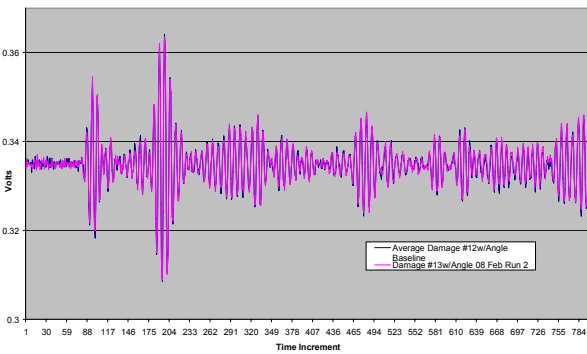

Pitch-Catch (5 to 4): 155kHz (Damage #12 w/ Angle Average - 08 Feb Damage #13 w/ Angle Run 2) Delta

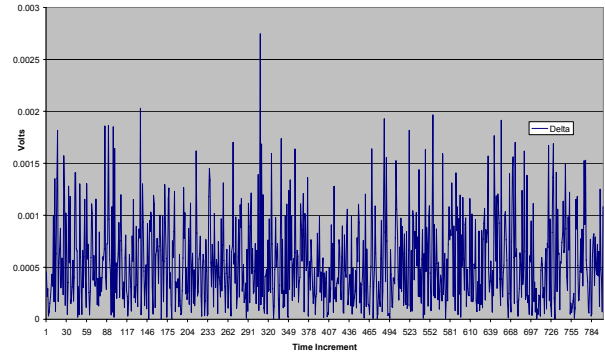

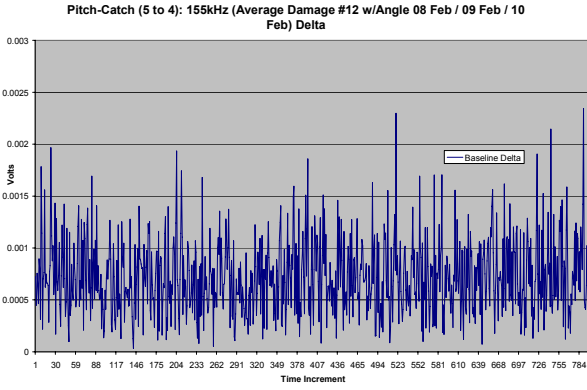

Pitch-Catch (Sensor 5 to 4): 09 Feb 07, Damage 13 w/ Angle, Damage 12 w/ Angle Baseline

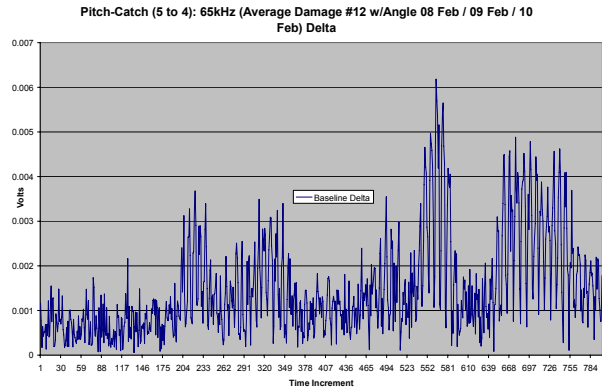
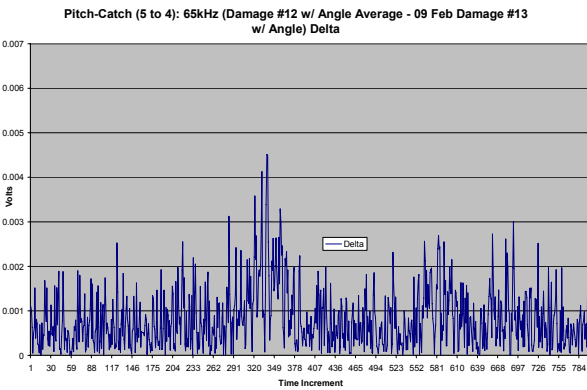
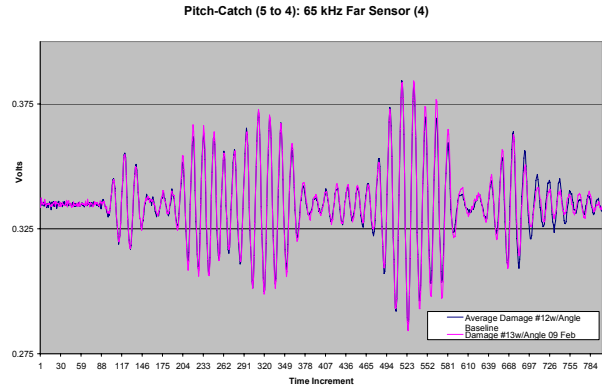
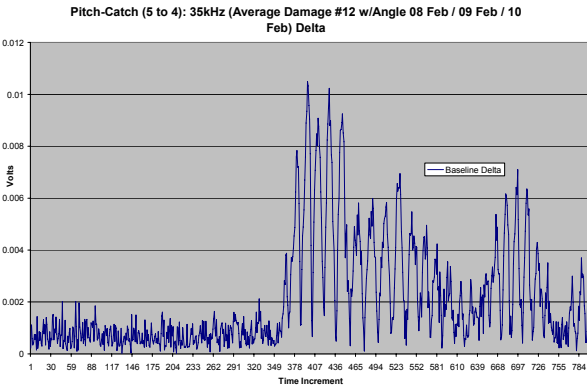
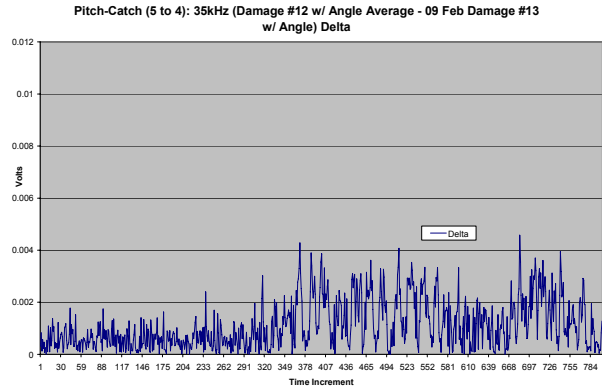
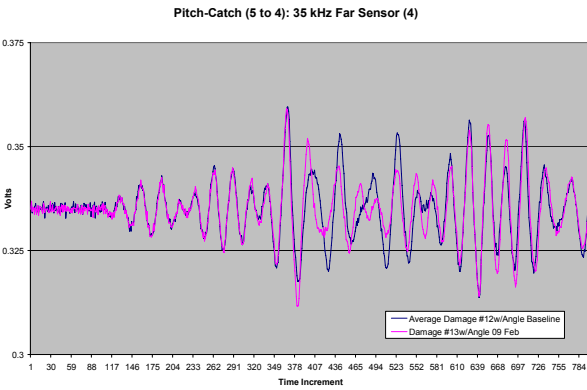

Pitch-Catch (5 to 4): 95 kHz Far Sensor (4)

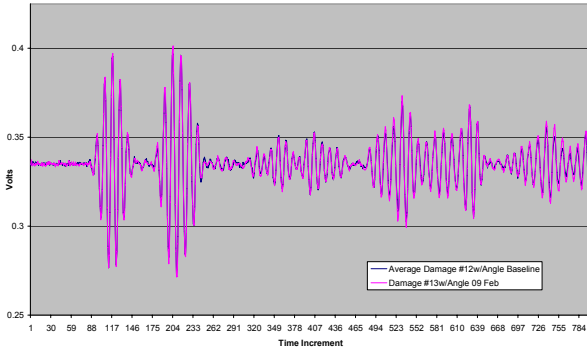

Pitch-Catch (5 to 4): 95kHz (Damage #12 w/ Angle Average - 09 Feb Damage #13 w/ Angle) Delta

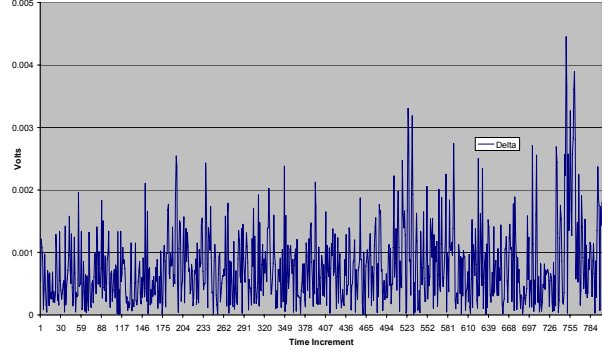

Pitch-Catch (5 to 4): 95kHz (Average Damage #12 w/ Angle 08 Feb / 09 Feb / 10 Feb) Delta

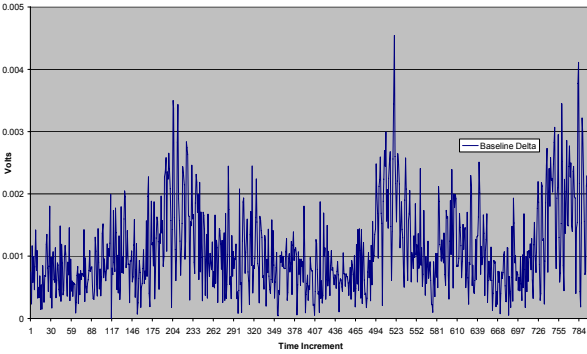

Pitch-Catch (5 to 4): 125 kHz Far Sensor (4)

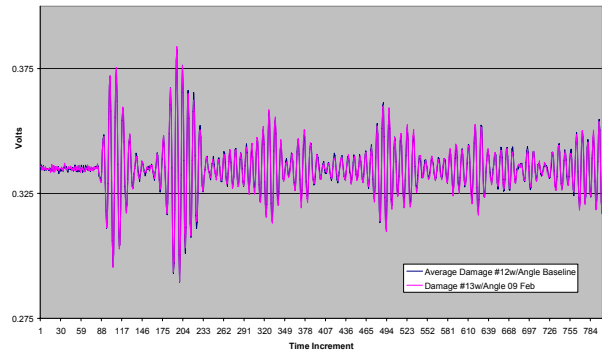

Pitch-Catch (5 to 4): 125kHz (Damage #12 w/ Angle Average - 09 Feb Damage #13 w/ Angle) Delta

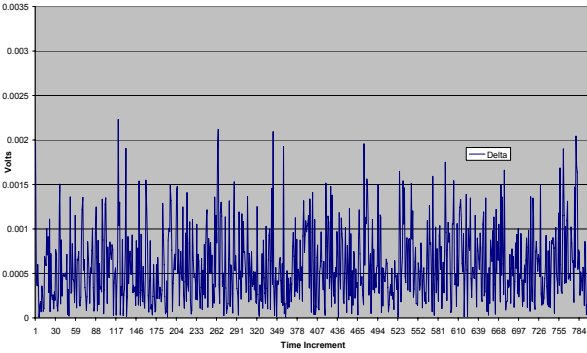

Pitch-Catch (5 to 4): 125kHz (Average Damage #12 w/ Angle 08 Feb / 09 Feb / 10 Feb) Delta

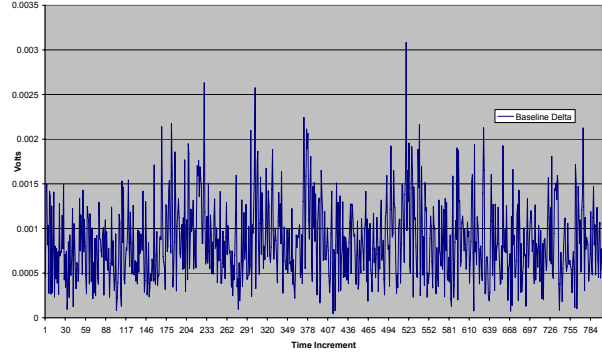

Pitch-Catch (5 to 4): 155 kHz Far Sensor (4)

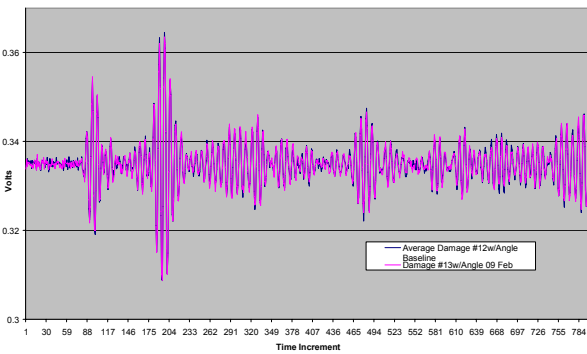

Pitch-Catch (5 to 4): 155kHz (Damage #12 w/ Angle Average - 09 Feb Damage #13 w/ Angle) Delta

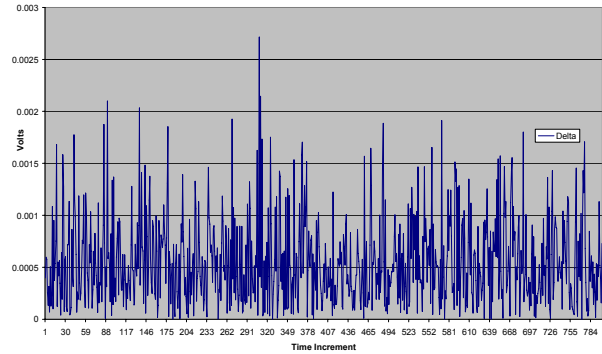

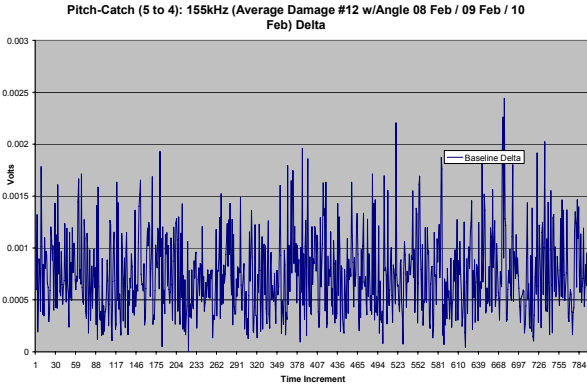

Pitch-Catch (Sensor 5 to 4): 10 Feb 07, Damage 13 w/ Angle, Damage 12 w/ Angle Baseline

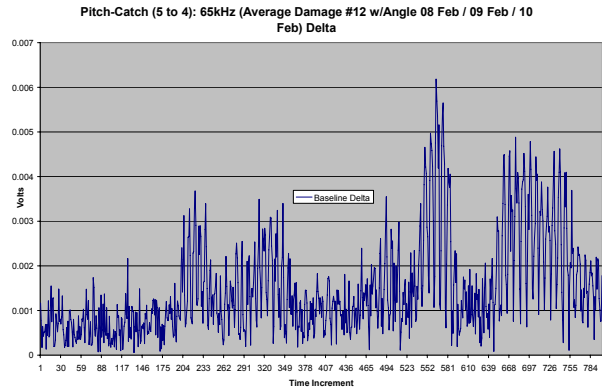
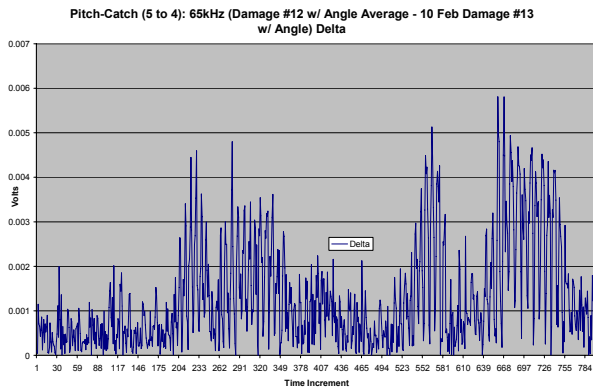
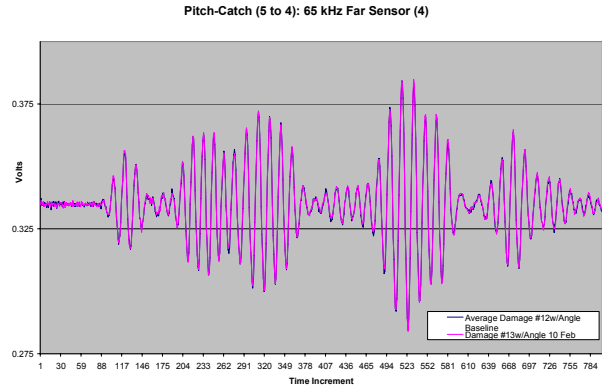
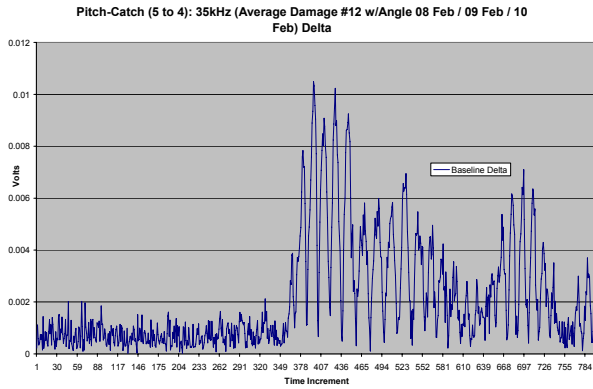
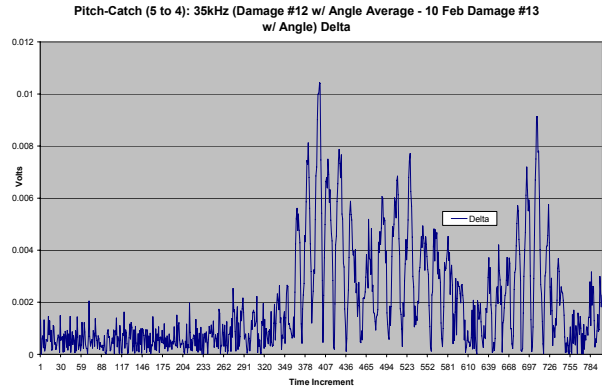
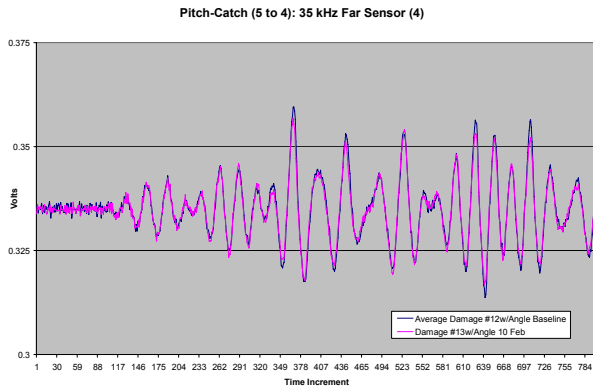

Pitch-Catch (5 to 4): 95 kHz Far Sensor (4)

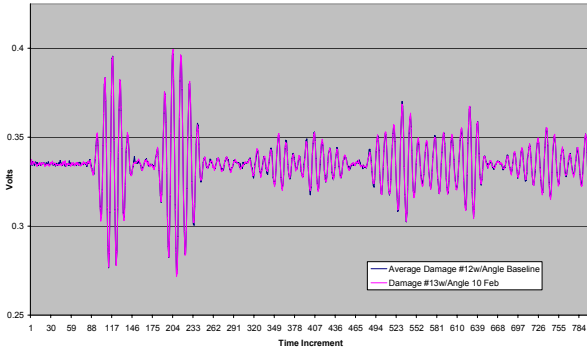

Pitch-Catch (5 to 4): 95kHz (Damage #12 w/ Angle Average - 10 Feb Damage #13 w/ Angle) Delta

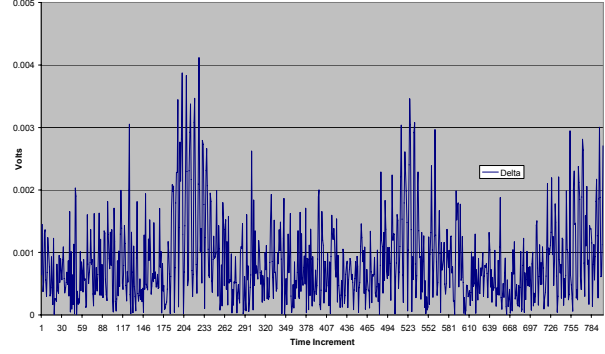

Pitch-Catch (5 to 4): 95kHz (Average Damage #12 w/ Angle 08 Feb / 09 Feb / 10 Feb) Delta

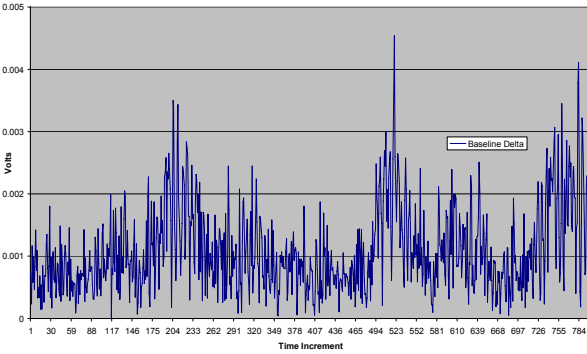

Pitch-Catch (5 to 4): 125 kHz Far Sensor (4)

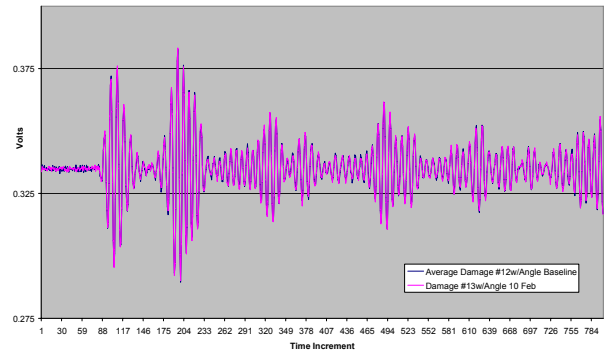

Pitch-Catch (5 to 4): 125kHz (Damage #12 w/ Angle Average - 10 Feb Damage #13 w/ Angle) Delta

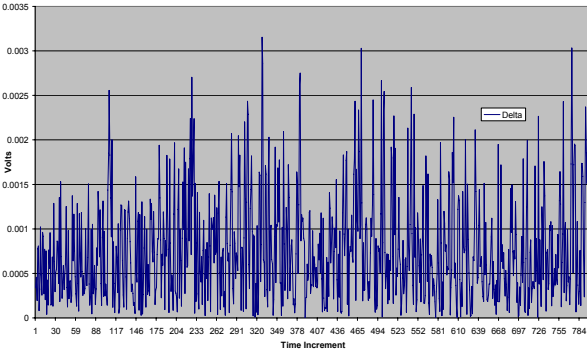

Pitch-Catch (5 to 4): 125kHz (Average Damage #12 w/ Angle 08 Feb / 09 Feb / 10 Feb) Delta

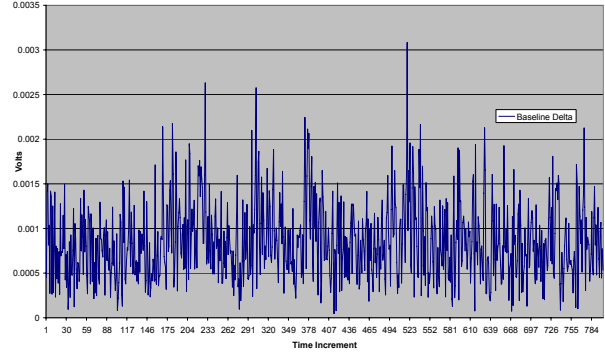

Pitch-Catch (5 to 4): 155 kHz Far Sensor (4)

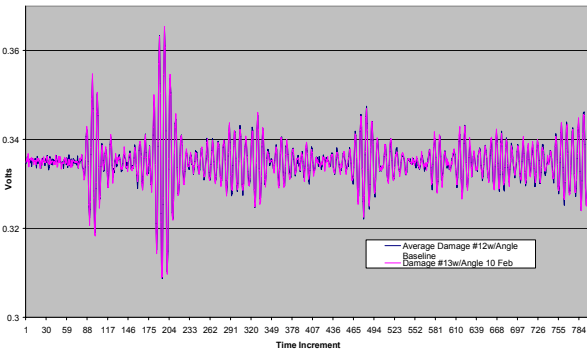

Pitch-Catch (5 to 4): 155kHz (Damage #12 w/ Angle Average - 10 Feb Damage #13 w/ Angle) Delta

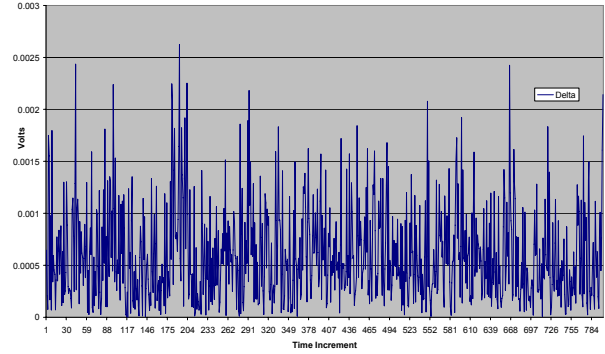

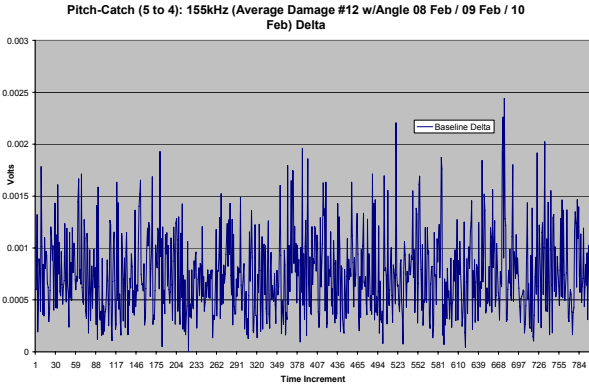

Pitch-Catch (Sensor 5 to 4): 15 Feb 07, Damage 14 w/ Angle, Damage 13 w/ Angle Baseline

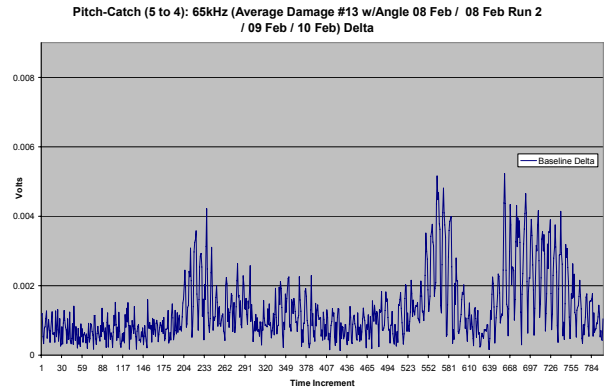
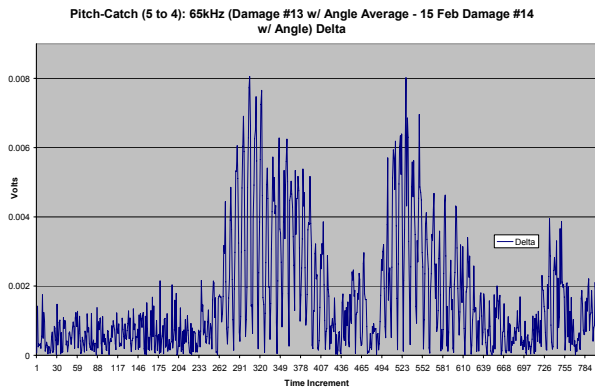
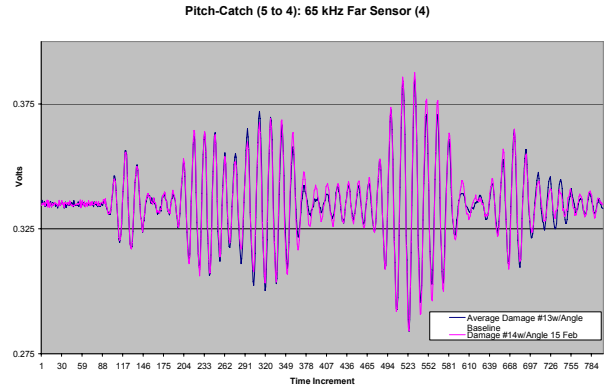
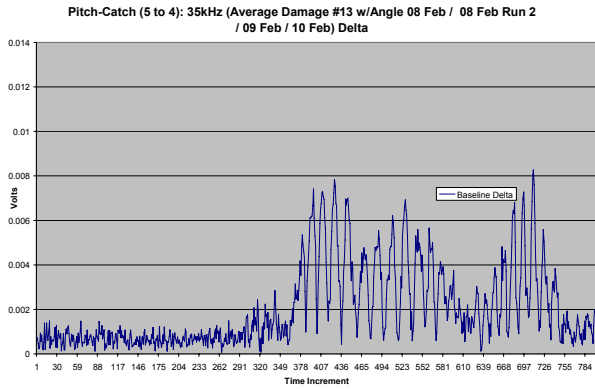
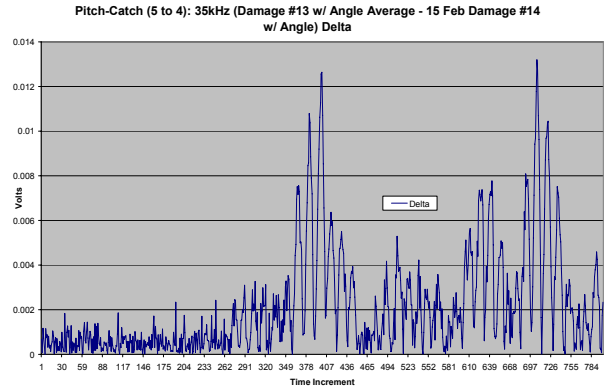
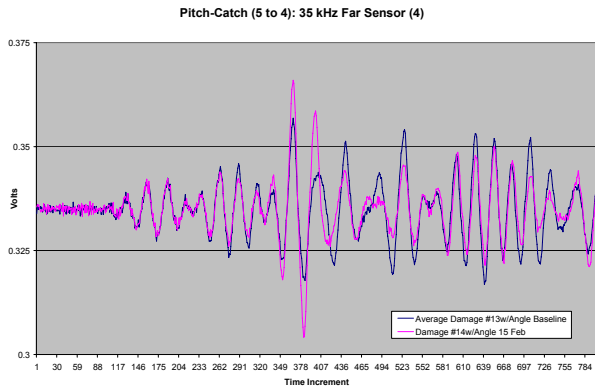

Pitch-Catch (5 to 4): 95 kHz Far Sensor (4)

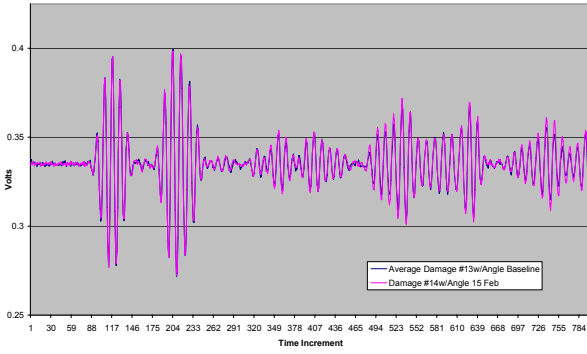

Pitch-Catch (5 to 4): 95kHz (Damage #13 w/ Angle Average - 15 Feb Damage #14 w/ Angle) Delta

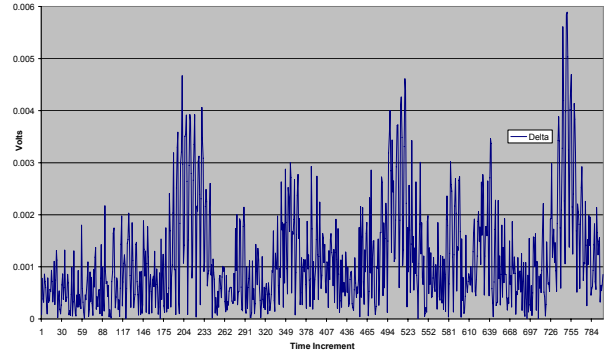

Pitch-Catch (5 to 4): 95kHz (Average Damage #13 w/Angle 08 Feb / 08 Feb Run 2 / 09 Feb / 10 Feb) Delta

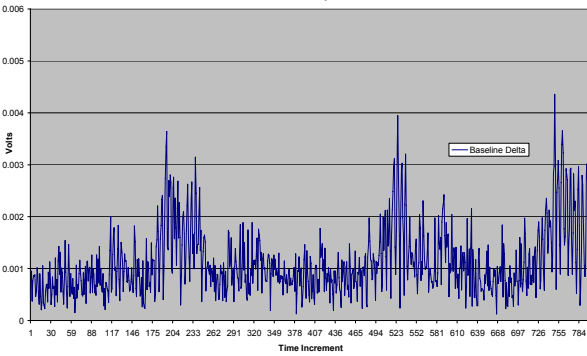

Pitch-Catch (5 to 4): 125 kHz Far Sensor (4)

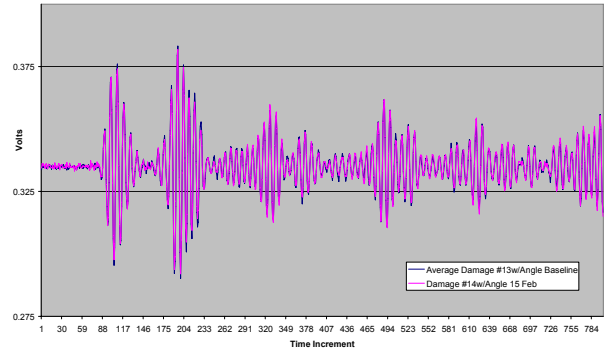

Pitch-Catch (5 to 4): 125kHz (Damage #13 w/ Angle Average - 15 Feb Damage #14 w/ Angle) Delta

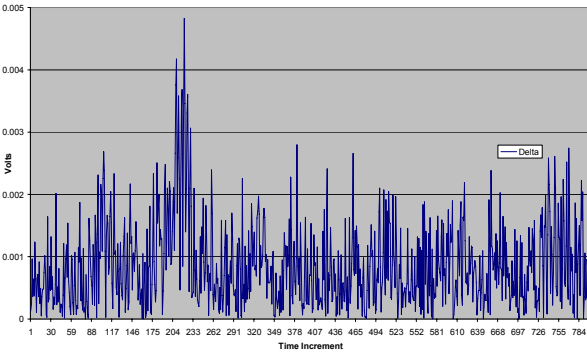

Pitch-Catch (5 to 4): 125kHz (Average Damage #13 w/Angle 08 Feb / 08 Feb Run 2 / 09 Feb / 10 Feb) Delta

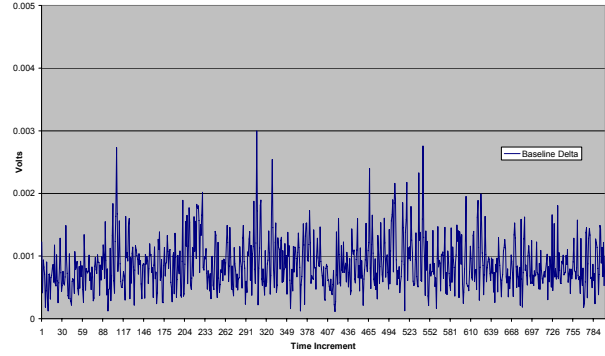

Pitch-Catch (5 to 4): 155 kHz Far Sensor (4)

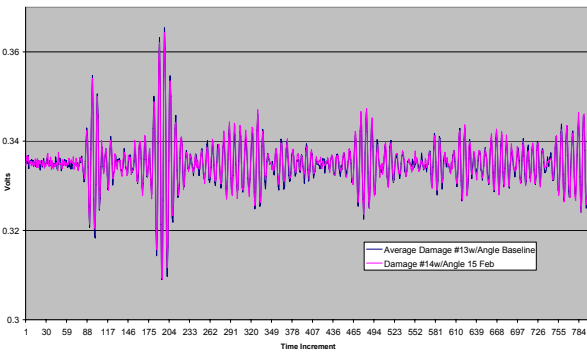

Pitch-Catch (5 to 4): 155kHz (Damage #13 w/ Angle Average - 15 Feb Damage #14 w/ Angle) Delta

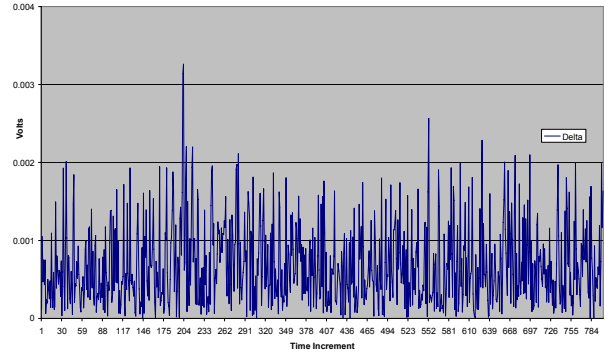

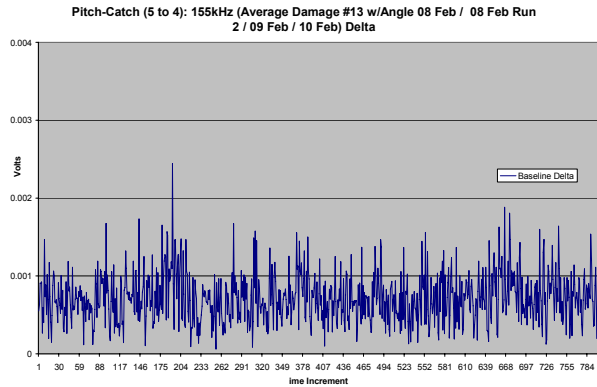

Pitch-Catch (Sensor 5 to 4): 16 Feb 07, Damage 14 w/ Angle, Damage 13 w/ Angle Baseline

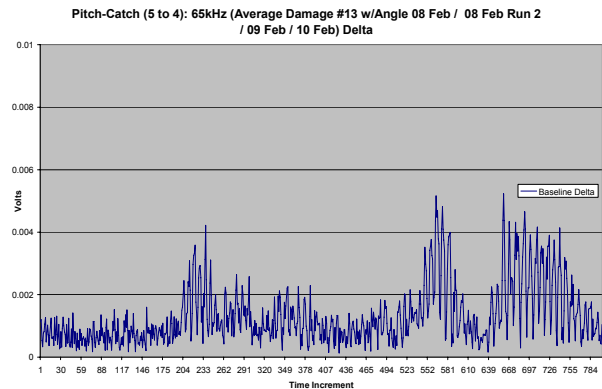
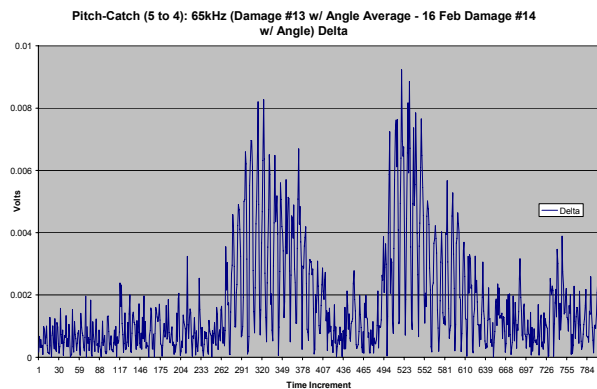
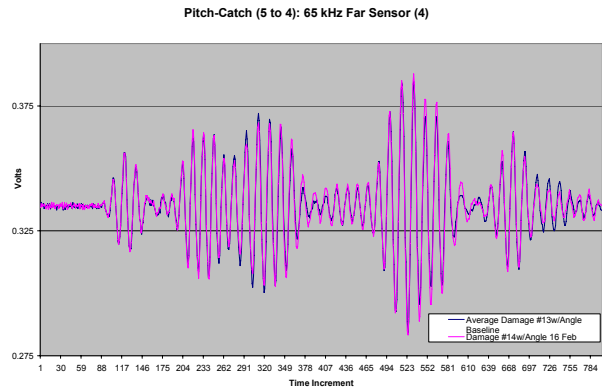
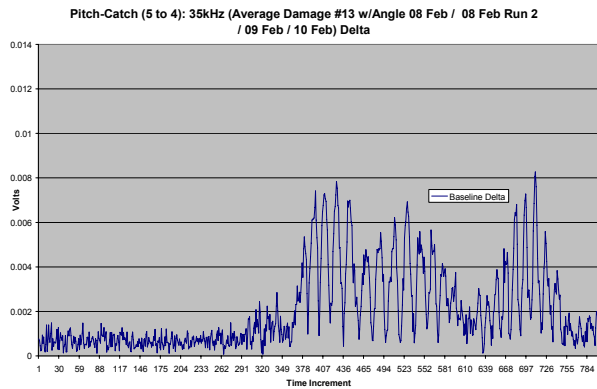
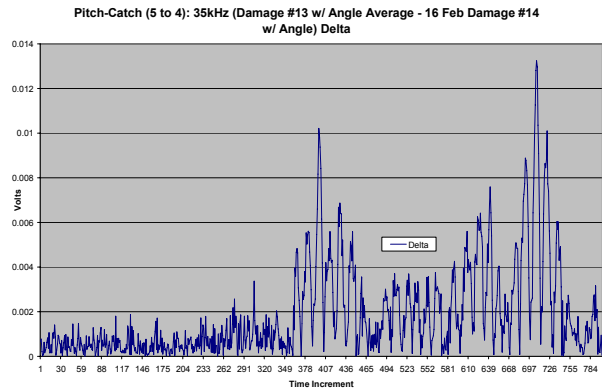
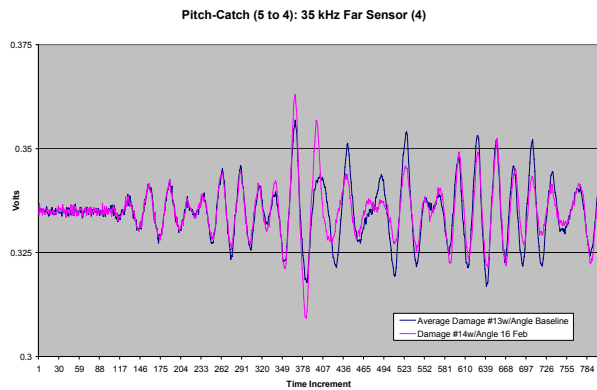

Pitch-Catch (5 to 4): 95 kHz Far Sensor (4)

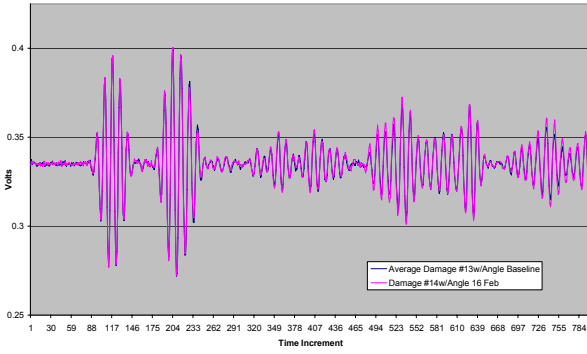

Pitch-Catch (5 to 4): 95kHz (Damage #13 w/ Angle Average - 16 Feb Damage #14 w/ Angle) Delta

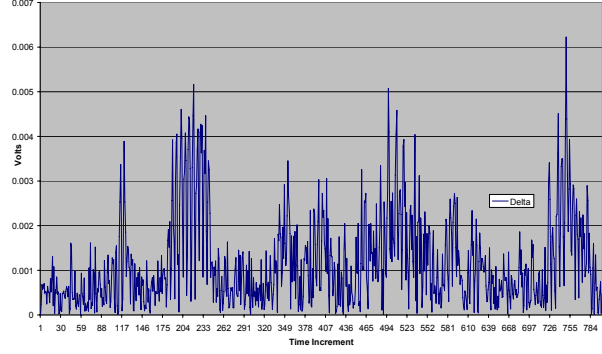

Pitch-Catch (5 to 4): 95kHz (Average Damage #13 w/Angle 08 Feb / 08 Feb Run 2 / 09 Feb / 10 Feb) Delta

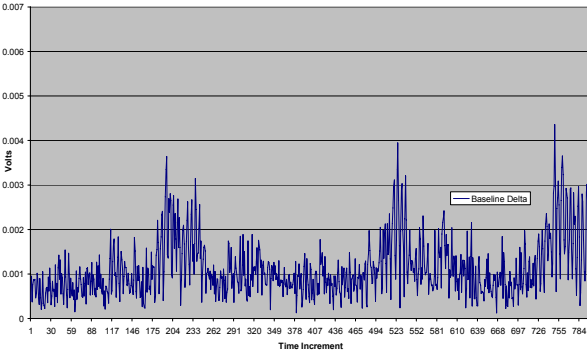

Pitch-Catch (5 to 4): 125 kHz Far Sensor (4)

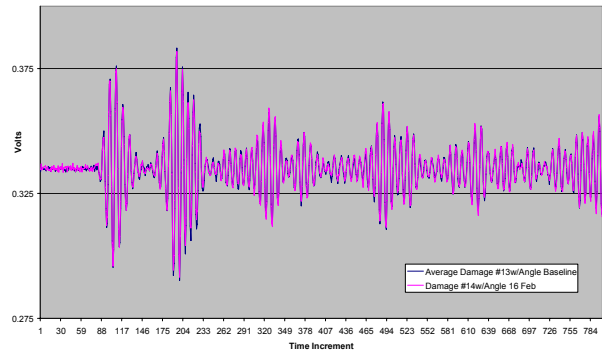

Pitch-Catch (5 to 4): 125kHz (Damage #13 w/ Angle Average - 16 Feb Damage #14 w/ Angle) Delta

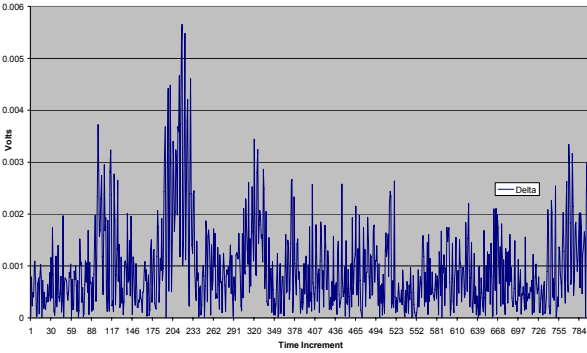

Pitch-Catch (5 to 4): 125kHz (Average Damage #13 w/Angle 08 Feb / 08 Feb Run 2 / 09 Feb / 10 Feb) Delta

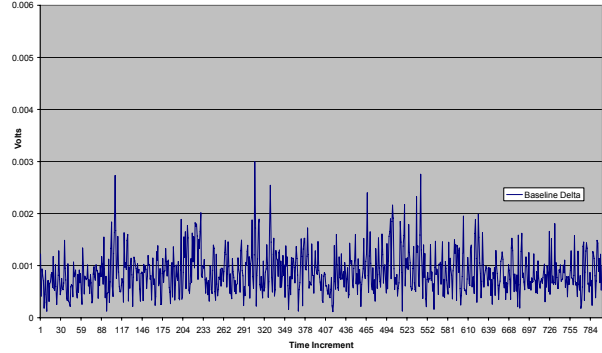

Pitch-Catch (5 to 4): 155 kHz Far Sensor (4)

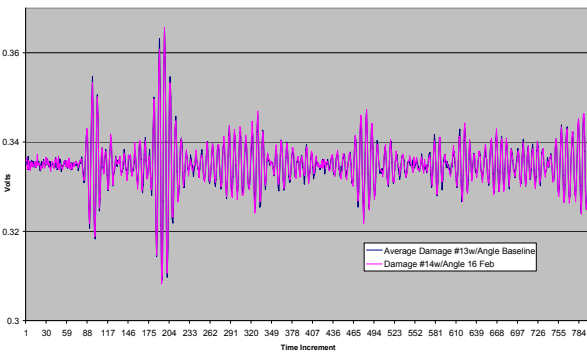

Pitch-Catch (5 to 4): 155kHz (Damage #13 w/ Angle Average - 16 Feb Damage #14 w/ Angle) Delta

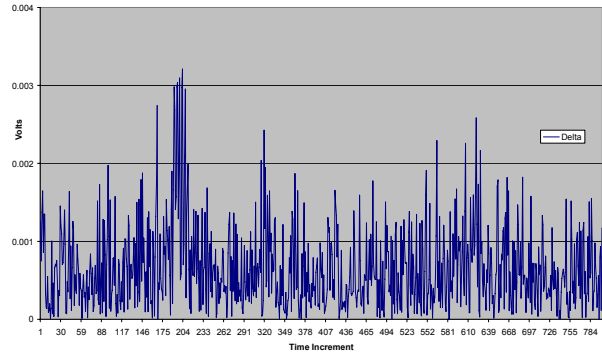

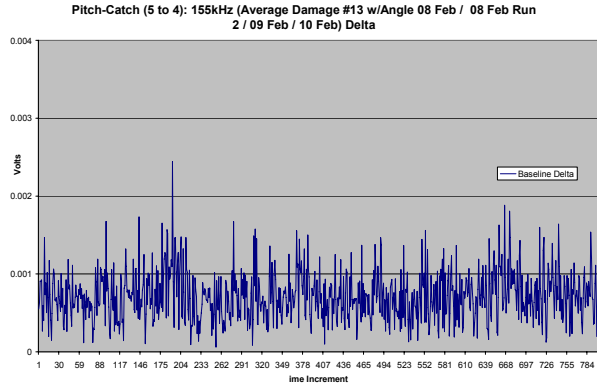

Pitch-Catch (Sensor 5 to 4): 19 Feb 07, Damage 14 w/ Angle, Damage 13 w/ Angle Baseline

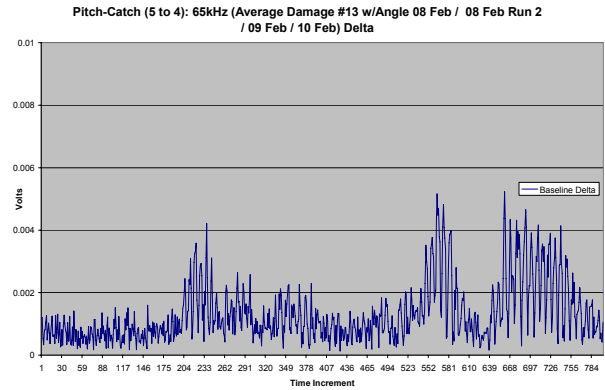
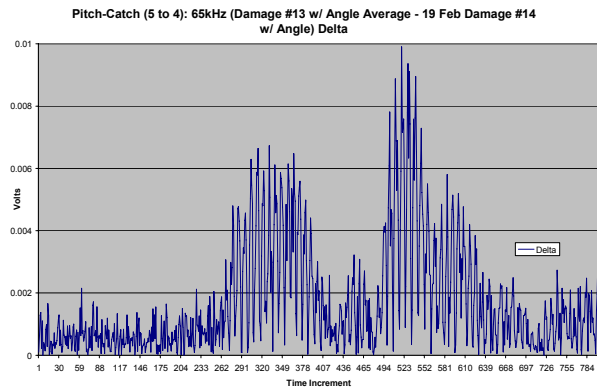
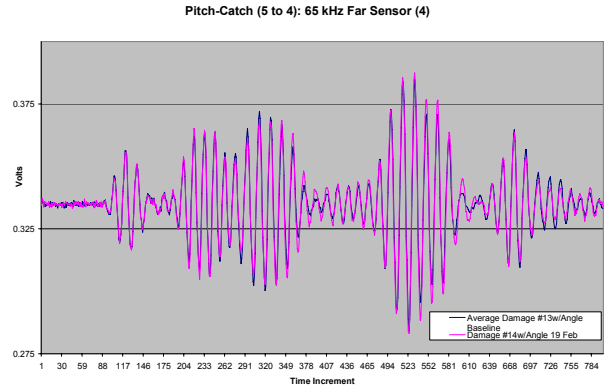
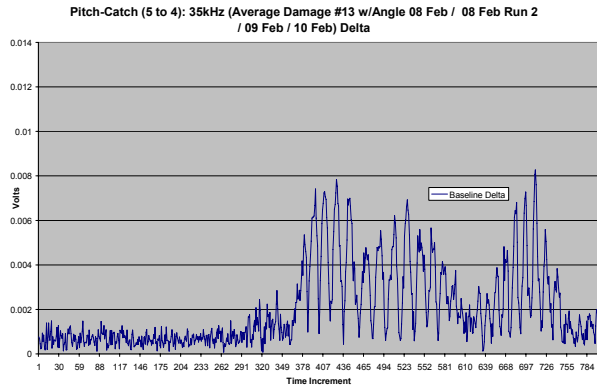
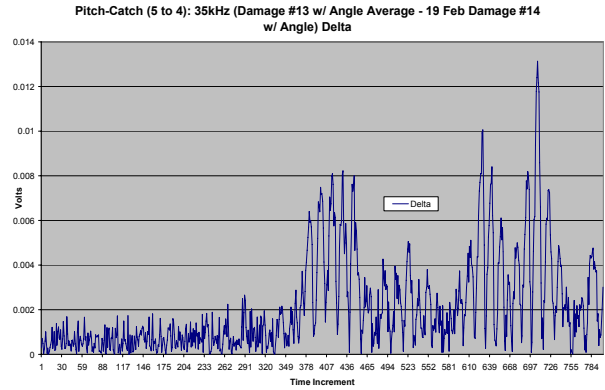
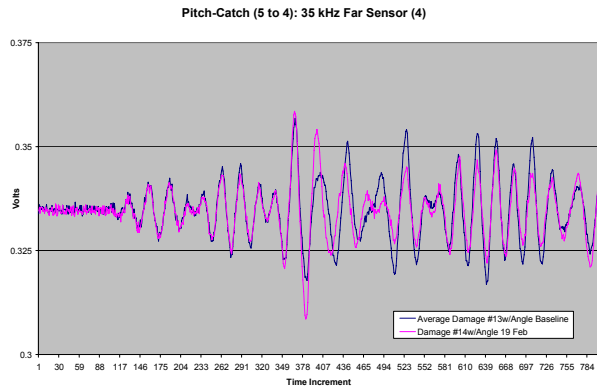

Pitch-Catch (5 to 4): 95 kHz Far Sensor (4)

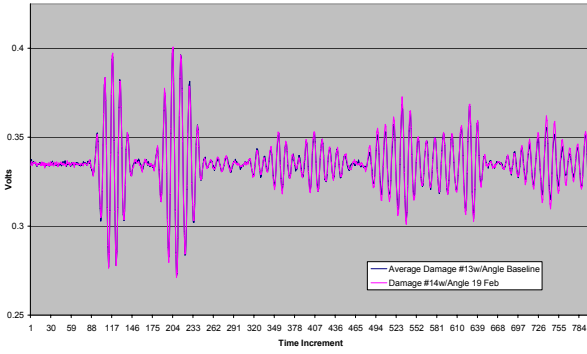

Pitch-Catch (5 to 4): 95kHz (Damage #13 w/ Angle Average - 19 Feb Damage #14 w/ Angle) Delta

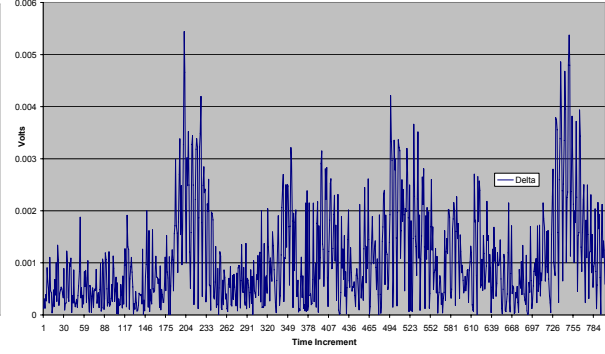

Pitch-Catch (5 to 4): 95kHz (Average Damage #13 w/Angle 08 Feb / 08 Feb Run 2 / 09 Feb / 10 Feb) Delta

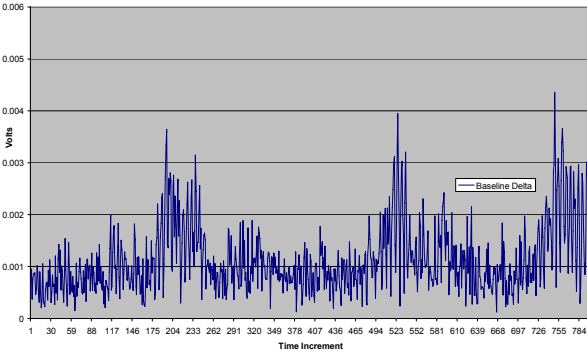

Pitch-Catch (5 to 4): 125 kHz Far Sensor (4)

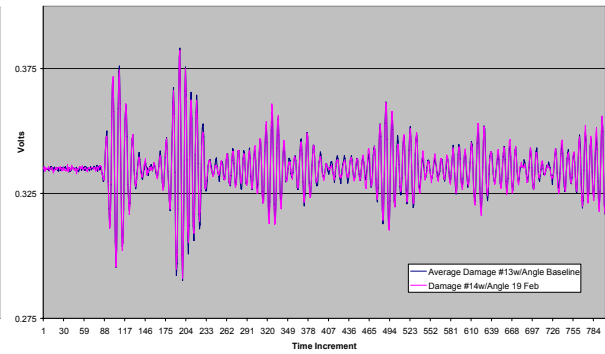

Pitch-Catch (5 to 4): 125kHz (Damage #13 w/ Angle Average - 19 Feb Damage #14 w/ Angle) Delta

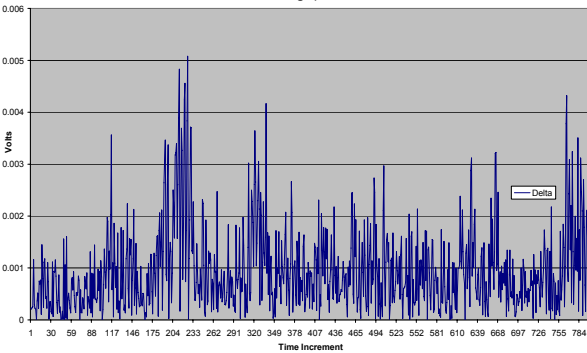

Pitch-Catch (5 to 4): 125kHz (Average Damage #13 w/Angle 08 Feb / 08 Feb Run 2 / 09 Feb / 10 Feb) Delta

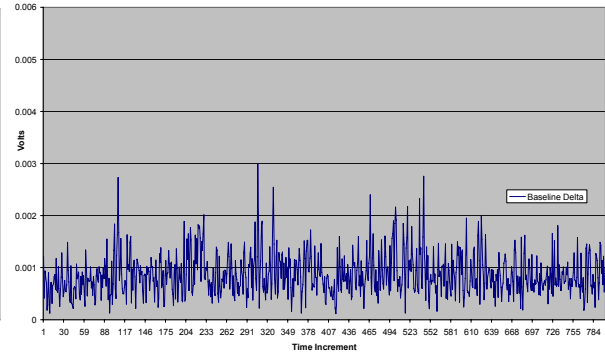

Pitch-Catch (5 to 4): 155 kHz Far Sensor (4)

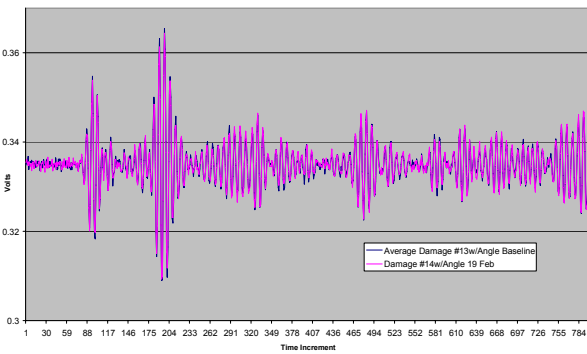

Pitch-Catch (5 to 4): 155kHz (Damage #13 w/ Angle Average - 19 Feb Damage #14 w/ Angle) Delta

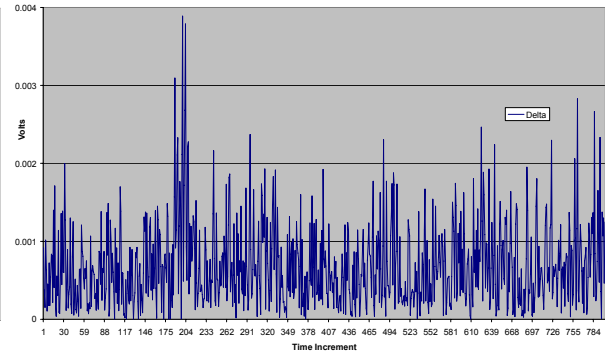

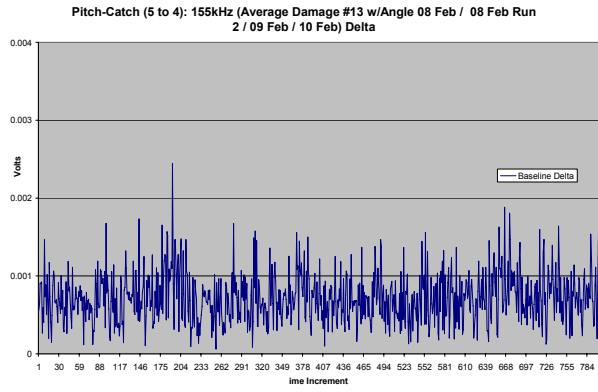

Bibliography

1. Albert, Alan P., Efstathios Antoniou, Stephen D. Leggiero, Kimberly A. Tooman, and Ramon L. Veglio. "A Systems Engineering Approach to Integrated Structural Health Monitoring for Aging Aircraft." Air Force Institute of Technology, Master's Thesis, March 2006.
2. Buede, Dennis. *Engineering Design of Systems: Models and Methods*. John Wiley and Sons, Inc, New York NY, 1999. 2nd ed.
3. Chambers, Jeffrey T., Brian L. Wardle, and Seth S. Kessler. "Durability Assessment of Lamb Wave-Based Structural Health Monitoring Nodes." *47th AIAA/ASME/ASCE/AHS/ASC Structures, Structural Dynamics, and Materials Conference*, May 2006, Newport, RI. Available at <http://www.metisdesign.com/pubs/SDM06.pdf>.
4. Dalessandro, Luca, and Daniele Rosato. "Finite-Element Analysis of the Frequency Response of a Metallic Cantilever Coupled With a Piezoelectric Transducer." *IEEE Transactions on Instrumentation and Measurement*, v.54, 1881-1890, October 2005.
5. DoD Architecture Framework Working Group. "DoDAF Architecture Framework Version 1.0, Deskbook". Electronic Copy, February 2004. Available at http://www.dod.mil/cio-nii/docs/DoDAF_v1_Deskbook.pdf.
6. DoD Architecture Framework Working Group. "DoDAF Architecture Framework Version 1.0, Volume I: Definitions and Guidelines". Electronic Copy, February 2004. Available at http://www.dod.mil/cio-nii/docs/DoDAF_v1_Volume_I.pdf.
7. DoD Architecture Framework Working Group. "DoDAF Architecture Framework Version 1.0, Volume II: Product Descriptions". Electronic Copy, February 2004. Available at http://www.dod.mil/cio-nii/docs/DoDAF_v1_Volume_II.pdf.
8. Eisner, Howard. *Essentials of Project and Systems Engineering Management*. John Wiley & Sons, Inc., New York NY, 2002. 2nd ed.
9. Hurt, Hugh H. Jr. *Fundamentals of Aircraft and Missile Structures*. United States Air Force Institute of Technology, 1960.

Bibliography

10. Kessler, Seth S., S. Mark Spearing, Mauro J. Atalla, Carlos E. S. Cesnik, and Constantinos Soutis. "Damage Detection in Composite Materials using Frequency Response Methods." *SPIE's 8th International Symposium on Smart Structures and Materials*, March 4-8 2001, Newport Beach, CA. Available at <http://web.mit.edu/sskess/www/papers/SPIE01.pdf>.
11. Kessler, Seth S., S. Mark Spearing, and Constantinos Soutis. "Damage Detection in Composite Materials using Lamb Wave Methods." *American Society for Composites Conference*, September 9-12 2001, Blacksburg, VA. Available at <http://web.mit.edu/sskess/www/papers/ASC01-043.pdf>.
12. Kessler, Seth S., S. Mark Spearing, and Constantinos Soutis. "Optimization of Lamb Wave Methods for Damage Detection in Composite Materials." *3rd International Workshop on Structural Health Monitoring*, September 12-14 2001, Stanford University. Available at <http://web.mit.edu/sskess/www/papers/SHM01.pdf>.
13. Kessler, Seth S. "Piezoelectric-Based In-Situ Damage Detection of Composite Materials for Structural Health Monitoring Systems." Massachusetts Institute of Technology, Ph.D. Thesis, January 2002. Available at <http://web.mit.edu/sskess/www/papers/phd-thesis.pdf>.
14. Kessler, Seth S., S. Mark Spearing, Mauro J. Atalla, Carlos E. S. Cesnik, and Constantinos Soutis. "Structural Health Monitoring in Composite Materials using Frequency Response Methods." *Composites Part B*, v.33, 87-95, January 2002. Available at http://web.mit.edu/sskess/www/papers/composites_part_b.pdf.
15. Kessler, Seth S., and S. Mark Spearing. "Design of a PiezoElectric Based Structural Health Monitoring System for Damage Detection in Composite Materials." *SPIE's 9th International Symposium on Smart Structures and Materials*, March 2002, San Diego, CA. Available at <http://web.mit.edu/sskess/www/papers/SPIE02.pdf>.
16. Kessler, Seth S., S. Mark Spearing, and Constantinos Soutis. "Structural Health Monitoring in Composite Materials using Lamb Wave Methods." *Smart Materials and Structures*, v.11, 269-278, April 2002. Available at http://web.mit.edu/sskess/www/papers/smart_structures.pdf.
17. Kessler, Seth S., and S. Mark Spearing. "In-Situ Sensor-Based Damage Detection of Composite Materials for Structural Health Monitoring Systems." *AIAA/ASME 43rd SDM Conference*, April 2002, Denver, CO. Available at <http://web.mit.edu/sskess/www/papers/SDM02.pdf>.

Bibliography

18. Kessler, Seth S., S. Mark Spearing, and Mauro J. Atalla. "In-Situ Damage Detection of Composite Materials using Lamb Wave Methods." *European Workshop on Structural Health Monitoring*, July 10-12 2002, Paris, France. Available at <http://web.mit.edu/sskess/www/papers/EWSHM02.pdf>.
19. Kessler, Seth S. and Christopher T. Dunn. "Optimization of Lamb Wave Actuating and Sensing Materials for Health Monitoring of Composite Structures." *SPIE's 10th International Symposium on Smart Structures and Materials*, March 3-6 2003, San Diego, CA. Available at <http://web.mit.edu/sskess/www/papers/SPIE03.pdf>.
20. Kessler, Seth S., Christopher E. Johnson, and Christopher T. Dunn. "Experimental Application of Optimized Lamb Wave Actuating/Sensing Patches for Health Monitoring of Composite Structures." *4th International Workshop on Structural Health Monitoring*, September 15-17 2003, Stanford University. Available at <http://web.mit.edu/sskess/www/papers/SHM03.pdf>.
21. Kessler, Seth S. and S. Mark Spearing. "Selection of Materials and Sensors for Health Monitoring of Composite Structures." *Materials Research Society Fall Meeting*, December 1-5 2003, Boston, MA. Available at <http://web.mit.edu/sskess/www/papers/MRS03.pdf>.
22. Kessler, Seth S., S. Mark Spearing, Yong Shi, and Christopher T. Dunn. "Packaging of Structural Health Monitoring Components." *SPIE's 11th International Symposium on Smart Structures and Materials*, March 14-18 2004, San Diego, CA. Available at <http://web.mit.edu/sskess/www/papers/SPIE04.pdf>.
23. Kessler, Seth S., and Dong Jin Shim. "Validation of a Lamb Wave-Based Structural Health Monitoring System for Aircraft Applications." *SPIE's 12th International Symposium on Smart Structures and Materials*, March 7-10 2005, San Diego, CA. Available at <http://web.mit.edu/sskess/www/papers/SPIE05.pdf>.
24. Kessler, Seth S., Kevin S. Amaratunga, and Brian L. Wardle. "An Assessment of Durability Requirements for Aircraft Structural Health Monitoring Sensors." *5th International Workshop on Structural Health Monitoring*, September 12-14 2005, Stanford University. Available at <http://web.mit.edu/sskess/www/papers/SHM05.pdf>.

Bibliography

25. Kessler, Seth S. "Certifying a Structural Health Monitoring System: Characterizing Durability, Reliability and Longevity." *1st International Forum on Integrated Systems Health Engineering and Management in Aerospace*, November 7-10 2005, Napa, CA. Available at <http://web.mit.edu/sskess/www/papers/ISHEM05.pdf>.
26. Kessler, Seth S., S. Mark Spearing, and Constantinos Soutis. "Structural Health Monitoring of Built-up Composite Structures using Lamb Wave Methods." Available at http://web.mit.edu/sskess/www/papers/intelligent_materials.pdf.
27. Kessler, Seth S., and S. Mark Spearing. "Structural Health Monitoring of Composite Materials using Piezoelectric Sensors." Available at http://web.mit.edu/sskess/www/papers/materials_evaluation.pdf.
28. Lamb, Horace. "On Waves in an Elastic Plate." *Proceedings of the Royal Society of London. Series A, Containing Papers of a Mathematical and Physical Character*, v.93, n.648, 114-128, March 1917.
29. Olsen, Steven E., Martin P. Desimio, and Mark M. Derriso. "Analytical Modeling of Lamb Waves for Structural Health Monitoring." *3rd European Workshop on Structural Health Monitoring*, 2006.
30. Ogishu, Toshimich, Masakazu Shimanuki, Satoshi Kiyoshima, Yoji Okabe, and Nobuo Takeda. "Feasibility studies on active damage detection for CFRP aircraft bonding structures." *Advanced Composite Materials*, v.15, 153-173, June 2005.
31. OO-ALC/LCEI. *Colombian Air Force A-37 Service Life Assessment Report*. April 2003.
32. Raghavan, Ajay, and Carlos E.S. Cesnik. "Finite-dimensional piezoelectric transducer modeling for guided wave based structural health monitoring." *Smart Materials and Structures*, v.14, 1448-1461, November 2005.
33. Robinson, William, Disele Welch, and Gary O'Neill. "The Need for a Systems Engineering Approach For Measuring and Predicting the Degradation of Aging Systems And How It Can Be Achieved." *Applied Vehicle Technology Panel Symposium on Life Management Techniques for Aging Air Vehicles*, NATO Research and Technology Agency, Manchester, UK, October 2001. Available at http://eosl.gtri.gatech.edu/remote_sensing/publications/NATO_Paper_Robinson.pdf.

Bibliography

34. Su, Zhongqing, and Lin Ye. "A fast damage locating approach using digital damage fingerprints extracted from Lamb wave signals." *Smart Materials and Structures*, v.14, 1047-1054, September 2005.
35. Tandon, G.P, R.Y. Kim, E. Ripberger, C.W. Lee, M.J. Roemer, and J. Ge. "Self-Diagnosis of Damage in Fibrous Composites Using Electrical Resistivity Measurements." *Nondestructive Evaluation and Health Monitoring of Aerospace Materials, Composites, and Civil Infrastructure, Proceedings of the SPIE*, v.6176, 11-22, March 2006.
36. <http://www.metisdesign.com>

Vita

Mr. Matthew S. Bond graduated from Huntington Beach High School in Huntington Beach, California. He attended Loyola Marymount University in Westchester, California and graduated with a Bachelor of Science in Mechanical Engineering in 1991. His first job was as a Flight Test Engineer working for McDonnell Douglas on the C-17 Globemaster program at the Air Force Flight Test Center, Edwards AFB. In 1997 he accepted a position as an Aerospace Engineer with the U.S. Air Force, completing a variety of assignments as a Flight Test Engineer working on the C-17, C-130J, B-1B, F-22 and Joint Strike Fighter programs. He moved to Wright-Patterson AFB in January 2005 and worked in the F-22 Program Office before accepting his current position as a Flight Test Engineer for the Air Force Research Lab. Upon graduation, Mr. Bond will continue his current assignment.

Capt. James A. Rodriguez graduated from Colorado Springs Christian High School in Colorado Springs, Colorado. He received an appointment to the U.S. Air Force Academy where he graduated with a Bachelor of Science degree in Aeronautical Engineering in May 2002 and commissioned into the U.S. Air Force. His first assignment was at Wright-Patterson AFB as a subsystem engineer in the F-22 System Program Office where he was responsible for fuels, hydraulics, landing gear, fire protection, and engine integration. In August 2005, he entered graduate school at the Air Force Institute of Technology. Upon graduation, he will be assigned to the Air Force Operational Test and Evaluation Center at Kirtland AFB, New Mexico.

1st Lt Hieu Nguyen graduated from Anaheim High School in Anaheim, California. He attended the University of California in Irvine, California and graduated with a Bachelor of Science in Mechanical Engineering and Aerospace Engineering in June 2002. He was commissioned into the U.S. Air Force through Officer Training School in April 2003. His first assignment was at Tinker AFB as a project engineer in the B-52 System Program Office. He entered graduate school at the Air Force Institute of Technology in August 2005. Upon graduation, he will be assigned to the AFRL Materials and Manufacturing Directorate.

REPORT DOCUMENTATION PAGE

*Form Approved
OMB No. 074-0188*

The public reporting burden for this collection of information is estimated to average 1 hour per response, including the time for reviewing instructions, searching existing data sources, gathering and maintaining the data needed, and completing and reviewing the collection of information. Send comments regarding this burden estimate or any other aspect of the collection of information, including suggestions for reducing this burden to Department of Defense, Washington Headquarters Services, Directorate for Information Operations and Reports (0704-0188), 1215 Jefferson Davis Highway, Suite 1204, Arlington, VA 22202-4302. Respondents should be aware that notwithstanding any other provision of law, no person shall be subject to a penalty for failing to comply with a collection of information if it does not display a currently valid OMB control number.
PLEASE DO NOT RETURN YOUR FORM TO THE ABOVE ADDRESS.

| | | | | | |
|---|----------------------|--|---|---|---|
| 1. REPORT DATE (DD-MM-YYYY) 22 Mar 07 | | 2. REPORT TYPE Master's Thesis | | 3. DATES COVERED (From - To) June 2006 - March 2007 | |
| 4. TITLE AND SUBTITLE A SYSTEMS ENGINEERING PROCESS FOR AN INTEGRATED STRUCTURAL HEALTH MONITORING SYSTEM | | | | 5a. CONTRACT NUMBER | |
| | | | | 5b. GRANT NUMBER | |
| | | | | 5c. PROGRAM ELEMENT NUMBER | |
| 6. AUTHOR(S) Matthew S. Bond, DR-02, USAF James A. Rodriguez, Captain, USAF Hieu T. Nguyen, 1st Lt, USAF | | | | 5d. PROJECT NUMBER | |
| | | | | 5e. TASK NUMBER | |
| | | | | 5f. WORK UNIT NUMBER | |
| 7. PERFORMING ORGANIZATION NAMES(S) AND ADDRESS(S) Air Force Institute of Technology Graduate School of Engineering and Management (AFIT/EN) 2950 Hobson Way WPAFB OH 45433-7765 | | | | 8. PERFORMING ORGANIZATION REPORT NUMBER AFIT/GSE/ENY/07-M-02 | |
| 9. SPONSORING/MONITORING AGENCY NAME(S) AND ADDRESS(ES) | | | | 10. SPONSOR/MONITOR'S ACRONYM(S) | |
| | | | | 11. SPONSOR/MONITOR'S REPORT NUMBER(S) | |
| 12. DISTRIBUTION/AVAILABILITY STATEMENT APPROVED FOR PUBLIC RELEASE; DISTRIBUTION UNLIMITED. | | | | | |
| 13. SUPPLEMENTARY NOTES | | | | | |
| 14. ABSTRACT The United States Air Force is continually researching ways to reduce costs associated with aircraft maintenance and improve operational safety. This study focuses on creating a systems engineering process to develop an Integrated Structural Health Monitoring System (ISHMS). The overarching process was then applied to design a conceptual ISHMS for a real-world scenario involving the F-15. Sensor selection, integration and testing were explored in detail using frequency response methods to detect structural damage. Testing was accomplished using a simplified structural specimen with Monitoring & Evaluation Technology Integration System (METIS) disk nodes attached at various locations. Two different METIS disk operation modes were utilized; pulse-echo and pitch-catch. Simulated and actual damage were introduced to the specimen allowing comparison between baseline and damaged tests. Comparative analysis validated the capabilities of frequency response sensors to detect damage. This analysis demonstrates that structural health monitoring systems using frequency response methods may be promising in the aerospace sector. | | | | | |
| 15. SUBJECT TERMS Systems Engineering, Structural Health, Monitoring, Frequency Response | | | | | |
| 16. SECURITY CLASSIFICATION OF: | | | 17. LIMITATION OF ABSTRACT UU | 18. NUMBER OF PAGES 240 | 19a. NAME OF RESPONSIBLE PERSON Dr. Som R. Soni AFIT/ENY |
| REPORT U | ABSTRACT U | c. THIS PAGE U | | | 19b. TELEPHONE NUMBER (Include area code) (937) 785-3636 x3420; e-mail: som.soni@afit.edu |