

AFRL-PR-WP-TP-2007-230

**HELIUM BREAKDOWN
CHARACTERISTICS UNDER 100 kHz
RANGE PULSED VOLTAGES IN
PARTIAL VACUUM FOR POINT-TO-
POINT ELECTRODE GEOMETRY
(POSTPRINT)**



**Kalyan Koppisetty, Esin B. Sozer, Hulya Kirkici,
and Daniel L. Schweickart**

MAY 2006

Approved for public release; distribution unlimited.

STINFO COPY

© 2006 IEEE

**The U.S. Government is joint author of the work and has the right to use, modify,
reproduce, release, perform, display, or disclose the work.**

**PROPULSION DIRECTORATE
AIR FORCE MATERIEL COMMAND
AIR FORCE RESEARCH LABORATORY
WRIGHT-PATTERSON AIR FORCE BASE, OH 45433-7251**

| REPORT DOCUMENTATION PAGE | | | | <i>Form Approved</i> OMB No. 0704-0188 | |
|--|------------------------------------|---|---|--|--|
| <p>The public reporting burden for this collection of information is estimated to average 1 hour per response, including the time for reviewing instructions, searching existing data sources, gathering and maintaining the data needed, and completing and reviewing the collection of information. Send comments regarding this burden estimate or any other aspect of this collection of information, including suggestions for reducing this burden, to Department of Defense, Washington Headquarters Services, Directorate for Information Operations and Reports (0704-0188), 1215 Jefferson Davis Highway, Suite 1204, Arlington, VA 22202-4302. Respondents should be aware that notwithstanding any other provision of law, no person shall be subject to any penalty for failing to comply with a collection of information if it does not display a currently valid OMB control number. PLEASE DO NOT RETURN YOUR FORM TO THE ABOVE ADDRESS.</p> | | | | | |
| 1. REPORT DATE (DD-MM-YY) May 2006 | | 2. REPORT TYPE Conference Paper Postprint | | 3. DATES COVERED (From - To) 14 May 2006 – 18 May 2006 | |
| 4. TITLE AND SUBTITLE HELIUM BREAKDOWN CHARACTERISTICS UNDER 100 kHz RANGE PULSED VOLTAGES IN PARTIAL VACUUM FOR POINT-TO-POINT ELECTRODE GEOMETRY (POSTPRINT) | | | | 5a. CONTRACT NUMBER F33615-02-D-2299-0024 | |
| | | | | 5b. GRANT NUMBER | |
| | | | | 5c. PROGRAM ELEMENT NUMBER 62203F | |
| 6. AUTHOR(S) Kalyan Koppisetty, Esin B. Sozer, and Hulya Kirkici (Auburn University) D.L. Schweickart (AFRL/PRPG) | | | | 5d. PROJECT NUMBER 3145 | |
| | | | | 5e. TASK NUMBER 33 | |
| | | | | 5f. WORK UNIT NUMBER 31453324 | |
| 7. PERFORMING ORGANIZATION NAME(S) AND ADDRESS(ES) Auburn University Auburn, AL 36849 | | | | 8. PERFORMING ORGANIZATION REPORT NUMBER | |
| Power Generation Branch (AFRL/PRPG) Power Division Propulsion Directorate Air Force Research Laboratory, Air Force Materiel Command Wright-Patterson Air Force Base, OH 45433-7251 | | | | | |
| 9. SPONSORING/MONITORING AGENCY NAME(S) AND ADDRESS(ES) Propulsion Directorate Air Force Research Laboratory Air Force Materiel Command Wright-Patterson Air Force Base, OH 45433-7251 | | | | 10. SPONSORING/MONITORING AGENCY ACRONYM(S) AFRL/PRPG | |
| | | | | 11. SPONSORING/MONITORING AGENCY REPORT NUMBER(S) AFRL-PR-WP-TP-2007-230 | |
| 12. DISTRIBUTION/AVAILABILITY STATEMENT Approved for public release; distribution unlimited. | | | | | |
| 13. SUPPLEMENTARY NOTES Conference paper published in the Proceedings of the 2007 International Power Modular Conference, published by IEEE. Paper contains color. © 2006 IEEE. The U.S. Government is joint author of the work and has the right to use, modify, reproduce, release, perform, display, or disclose the work. PAO Case Number: AFRL/WS 07-1322; Date cleared: 05 Jun 2007. | | | | | |
| 14. ABSTRACT In this paper we present our work on breakdown studies conducted in helium at partial vacuum conditions for a point-to-point electrode setup. A high frequency pulsed voltage signal is applied across the electrodes and the voltage-current characteristics are observed. The applied signal consists of a train of square pulses in the frequency range of 50 to 200 kHz with 50% duty cycle and rise/fall times in the range of 20-30 ns. These studies were conducted to understand and compare the role of the pulse repetition rate in electrical breakdown initiation in low pressure conditions. Preliminary data of voltage and current waveforms, along with the light emission data are presented. The optical data collected by a PMT (Photo Multiplier Tube) as a function of the time is presented in comparison to the varying voltage. | | | | | |
| 15. SUBJECT TERMS Breakdown, Pulsed Voltage, Helium | | | | | |
| 16. SECURITY CLASSIFICATION OF: | | | 17. LIMITATION OF ABSTRACT: SAR | 18. NUMBER OF PAGES 10 | 19a. NAME OF RESPONSIBLE PERSON (Monitor) Daniel L. Schweickart 19b. TELEPHONE NUMBER (Include Area Code) N/A |
| a. REPORT Unclassified | b. ABSTRACT Unclassified | c. THIS PAGE Unclassified | | | |

Helium Breakdown Characteristics under 100 kHz Range Pulsed Voltages in Partial Vacuum for Point-to-point Electrode Geometry*

Kalyan Koppisetty[‡], Esin B. Sozer¹, Hulya Kirkici¹, D. L. Schweickart²

¹Auburn University, Auburn, Alabama 36849, USA,

²Air Force Research Laboratory, Wright Patterson Air Force Base, Ohio 45433, USA.

Abstract- In this paper we present our work on breakdown studies conducted in helium at partial vacuum conditions for a point-to-point electrode setup. A high frequency pulsed voltage signal is applied across the electrodes and the voltage-current characteristics are observed. The applied signal consists of a train of square pulses in the frequency range of 50 to 200 kHz with 50% duty cycle and rise/fall times in the range of 20-30 ns. These studies were conducted to understand and compare the role of the pulse repetition rate in electrical breakdown initiation in low pressure conditions. Preliminary data of voltage and current waveforms, along with the light emission data are presented. The optical data collected by a PMT (Photo Multiplier Tube) as a function of the time is presented in comparison to the varying voltage.

I. INTRODUCTION

Power systems and devices operating in vacuum or space environment are susceptible to partial discharges, corona, or volume discharges due to the partial vacuum conditions. PD and breakdown studies have been conducted on electrical equipment operating in such environments for decades. Of particular interest here are spacecraft system designs that must meet stringent fault-free operation for long periods without maintenance. Electrical and electronic equipment used in space applications must be designed to operate over a wide range of pressures and temperatures. Most of the studies conducted and techniques developed so far are for terrestrial equipment and so at atmospheric conditions or higher pressures. However, at low pressure or vacuum conditions, these techniques may not be applicable. With the advancement in spacecraft design and use of newer 120 V dc power sources in some of the systems (ISS), spacecraft subsystems are subjected to partial discharge and corona due to higher switching frequencies and higher voltage supplies.

With increasing demand and a need for more sophisticated equipment onboard, the new generation of space vehicles has higher power requirements and is likely to utilize higher voltages than the traditional 28 Vdc for onboard power distribution. This can already be witnessed in some of the

subsystems of the International Space Station (ISS), which utilize 120 Vdc. The availability of switching power supplies operating at higher intermediate frequencies makes it important to consider the effects of these higher operating frequencies on corona and gas breakdown in space applications. These phenomena within power system components are considered unacceptable in systems where long lifetime and reliability is of extreme importance [1].

The earlier work presented in the literature suggests that the breakdown strength of certain gases falls off drastically at frequencies of 10s of kHz, which is not theoretically predictable [2]. Although there have been studies on the influence of frequency of the applied voltage signal on gas breakdown over specific frequency range, this behavior over the range below 1 MHz is not entirely understood. In addition, it was observed early in the space program that the existing data cannot be extrapolated for miniature systems with smaller electrode gaps operating at very low pressures. Our recent studies confirm that high frequency operation in space could be a major concern when designing space power systems [3], and that the breakdown voltage levels at high frequencies (< 1 MHz) can indeed be lower than the dc breakdown voltage levels, at certain pressures.

Partial discharges are detrimental to a power system as they are constant sources of power loss and electrical noise (EMI). Furthermore, they can be a major problem at the component level, causing solid insulation deterioration and eventual breakdown. With the development of the newer space and aerospace vehicles using higher voltages than traditional 28 V dc power, the need for data to design high voltage space power systems is more desirable. Currently, there are several initiatives within the government agencies (such as NASA and Air Force), planning to use 270-volt distribution power [1]. Some sub-systems also use high frequency (in the 10s of kHz) voltages, for switched mode power conversion. In general, the corona or partial discharge initiation voltage is a function of several design and environmental parameters. The most important factors to be noted are the operation pressure, the electrode gap/geometry, and the frequency and voltage level of the applied power within a power system [4]. Commercial dc

* Work supported by the *Universal Technology Corp.*, under contract to the Air Force Research Laboratory, Propulsion Directorate, contract number F33615-02-D-2299/DO-0024

‡ email: kalyan_k@ieee.org

to dc voltage converters typically operate with intermediate frequencies in the range of 20 to 100 kHz. These voltages and frequencies are considered problem areas for corona and breakdown concerns in flight vehicles subjected to low pressure environments [5].

This paper summarizes our current work by giving a brief description of the experimental setup, the procedures followed, and the preliminary results on breakdown characteristics of helium observed for pulsed voltages at 50, 100, 150, and 200 kHz under partial vacuum conditions.

II. EXPERIMENTAL SETUP

The experimental setup basically consists of a vacuum chamber, high voltage power supply and a data acquisition system. The vacuum chamber is equipped with an optical window, in addition to the ports for electrical input, pressure gauges, and gas input/output. The high voltage supply system consists of a signal generator which is fed into a pulse generator to produce the output waveform with the desired characteristics. The electrode system consists of two stainless steel point electrodes placed 1 cm apart. These point electrodes are machined to a tip radius of 0.5 mm.

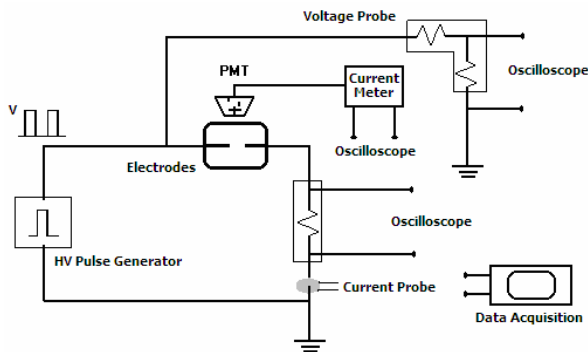

Figure 1. Schematic of the experimental setup.

The chamber is purged by first pumping out the gases, then filling with helium for each experiment set. Once the purge is completed, helium is then used as the operating gas. The chamber pressure is maintained constant throughout a particular set of breakdown events by controlling the gas inlet valve and the vacuum pump. The flow rate is maintained so as to keep the pressure constant. It should be noted, however, that the flow rate is low enough to ignore the effects of a flowing gas on the breakdown phenomenon. The breakdown experiments were conducted as pressure is varied from 0.2 torr all the way up to 10 torr. The power supply is a PVX-4150 pulse generator, manufactured by Directed Energy Inc., with rising and falling edges under 25 ns. A constant square wave is fed into the pulse generator at the selected frequency and the applied voltage is then gradually increased until a breakdown event is observed. For a particular frequency, at every pressure level, three successive breakdown events are recorded and these voltages are averaged to form the data point for that particular pressure. The chamber is then flushed with helium before taking the next data set to avoid any contamination. The experimental set-up, including the power source and the

diagnostics, is shown in Figure 1 and the electrode setup in Figure 2.

Voltage and current waveforms, along with the light emission data from the discharges are collected. Optical data is collected by means of video camera for optical images and by a PMT the temporal record of the light emitted from the breakdown. The videos captured are then converted into frame-by-frame still images for better understanding of the step-by-step process.

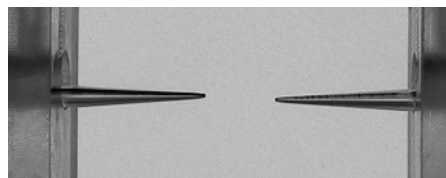

Figure 2. Point-to-Point electrode setup (tip radius – 0.5mm, electrode gap – 10mm).

III. EXPERIMENTAL RESULTS AND DISCUSSION

Earlier studies on the high frequency breakdown of helium for the point-to-point configuration were reported previously [3, 6]. These studies were conducted using a dc shifted sinusoid and for frequencies under 50 kHz. It was shown that the breakdown voltage decreases as pressure increases and at around 1.5-2.0 torr, the breakdown curve seems to reach a steady value. As seen in Figure 3, the breakdown voltage characteristic for ac exhibits a pattern similar to the typical Paschen curve for dc breakdown in gases over the limited range investigated. Further data above 3 torr is needed for a better comparison.

In this work, the applied voltage signal consists of a pulse train with rise and fall times under 25 ns and with a 50% duty cycle. Figure 4 shows a typical voltage waveform acquired just before the breakdown event and then during the breakdown event. As can be observed, there is a small but sudden drop in the voltage at the breakdown. Figure 4 also shows the optical emission as captured by the PMT. The first arrow (on the left) in the figure shows the initiation of the optical emission signal. The corresponding optical emission data is also acquired as shown in Figure 5 (shown over a wider time scale to show the overall behavior), and the growth of the discharge current over time is presented in Figure 6. The peak currents correspond to the sudden change in voltage levels of Figure 4. The results of the experiments conducted can be summarized as shown in Figure 7. In general, it was observed that as the applied frequency is increased, the breakdown voltage decreases, though not in a linear fashion. Furthermore, for frequencies of 50, 100 and 150 kHz, the voltage minimum seems to occur around the 1.5-2.0 torr region, similar to what was reported earlier [3].

To better understand the dependence of the breakdown voltage on the applied frequency, data was also collected at a fixed gas pressure and by varying the applied frequency. Figure 8 shows this data for 1200 millitorr. As observed, there is a consistent decrease in the breakdown voltage as the applied frequency is increased; this is in accordance with the rest of the data summarized in Figure 8.

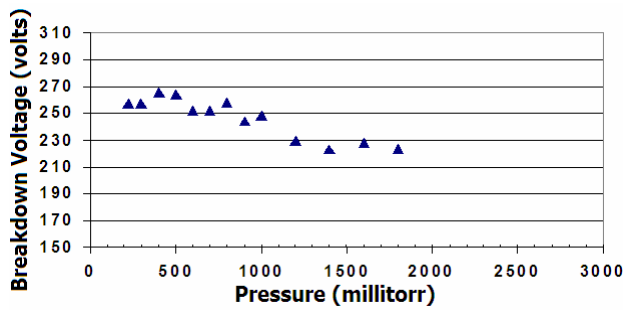

Figure 3. Breakdown voltage as a function of pressure for point-to-point electrode configuration with 1-cm gap distance for 20 kHz DC shifted sinusoid signal [3].

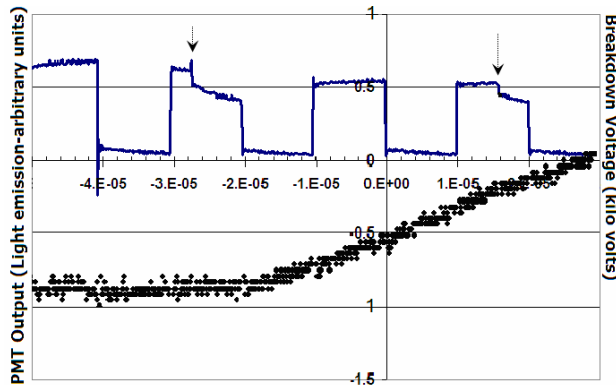

Figure 4. A typical applied voltage pulse (top) at 50 kHz and 6 torr showing the pulse shape just before the breakdown (first pulse on left) and then during the breakdown (the pulses with arrows). Also included is the light emission data (bottom).

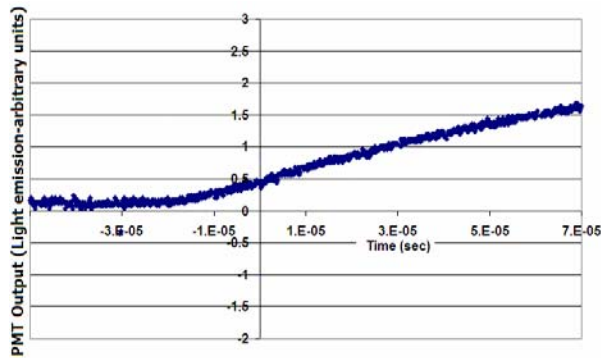

Figure 5. Optical emission data acquired through a PMT for the event in Figure 4 (the inflection point of the data corresponds to the breakdown event marked by the vertical line on the second pulse in Figure 4).

The frame-by-frame images obtained by the video camera for the same experimental conditions are shown in Figure 9. The voltage and light emission waveforms suggest that the breakdown is a relatively short event occurring within a few microseconds. Once the breakdown is initiated, a voltage collapse and a transient current are recorded. The light emission from the electrode gap is observed for several cycles of the applied voltage signal (Figures 4, 5), although the voltage waveforms indicate this process to be in the microsecond range (Figure 4).

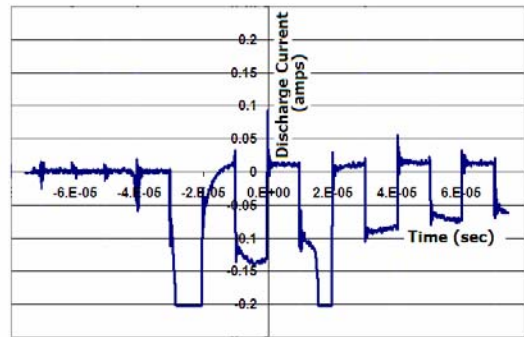

Figure 6. Discharge current over time for the event shown in Figure 4. First and third peaks of the current pulses are clipped off, due to measuring instrument saturation.

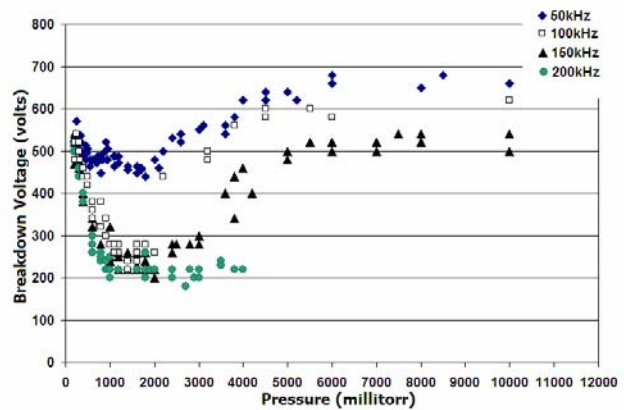

Figure 7. Breakdown voltage as a function of pressure at 4 different frequencies for point-to-point electrode setup in helium.

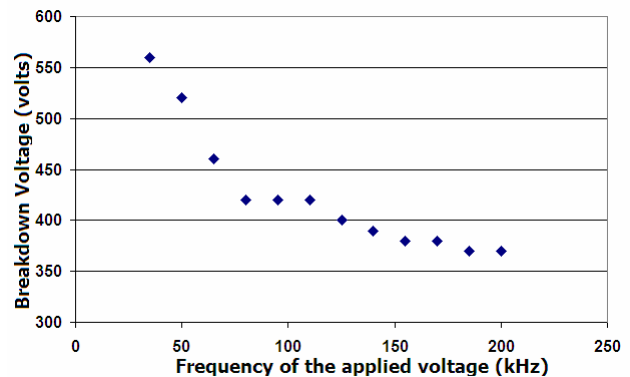

Figure 8. Breakdown voltage variation with increasing applied frequency at 1200 millitorr pressure.

In general, a low intensity glow discharge is observed around both the electrodes, but is mainly seen at the cathode region at higher pressure, and at the anode region at lower pressures. The glow is relatively diffused at lower pressure, making it appear to have a lower intensity, while at higher pressure, the glow is more confined. Optical emission waveforms recorded by PMT show that there is higher emission rate at lower pressures, compared to more confined glow with lower optical intensity at higher pressure.

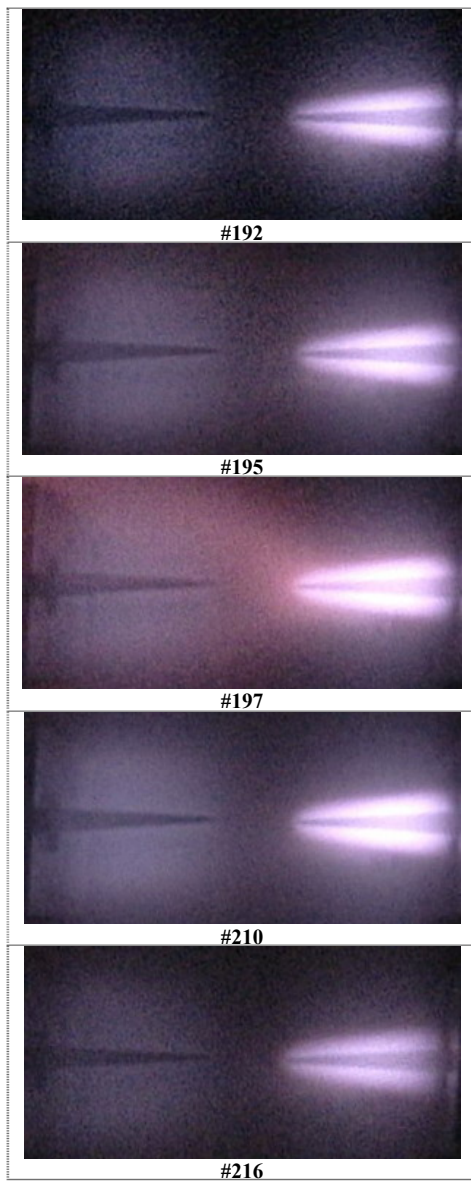

Figure 9. Optical video images of the 50 kHz breakdown event shown frame-by-frame, at: 5 torr. The video images are recorded with 30 frames/sec, corresponding to about 33 milli sec gap between each consecutive frame.

As seen in the voltage waveforms of Figure 4, most of the breakdown events occur at the beginning of the flat edge of the pulse. Once the discharge is initiated, there is a small but sudden fall in the voltage, as seen in the waveform. As the power system is not designed to trip-off when the breakdown initiates, the discharge continues to be fed even after the breakdown initiation. The long duration and increase of optical emission amplitude as time progresses is due to the glow discharge established between the electrodes after the breakdown (Figure 5). During this process, the light emission steadily increases, following an exponential growth. It was further observed that the breakdown starts with a transient current and the magnitude of this transient usually increases as the pressure increases.

IV. CONCLUSIONS

A very clear and consistent fall in breakdown voltage is observed as the applied frequency is increased from 50 kHz to 200 kHz in helium for a point-to-point electrode configuration. The pressure versus breakdown voltage plots show a voltage minimum around 1.5-2.0 torr for this frequency range for the limited pressure range investigated. The data also suggests that the breakdown voltage exhibits a pattern very similar to the Paschen curve for dc breakdown over this pressure range and the frequencies used.

V. REFERENCES

- [1] Spacecraft High Voltage Design Guidelines (in preparation), W. G. Dunbar, David K. Hall, H. Kirkici, D. L. Schweickart, G. Barry Hillard, NASA-AFRL Design Guide.
- [2] W. Pfeiffer, "High-Frequency Voltage Stress of insulation", IEEE TEI, pp. 239-246, April 1991.
- [3] K. Koppisetty, H. Kirkici, "Gaseous Breakdown at High Frequencies under Partial Vacuum", IEEE-CEIDP Annual Report, pp. 451-454, 2003.
- [4] J. M. Meek and J. D. Craggs, "Electrical breakdown of gases", Wiley Newyork, 1978.
- [5] K. Koppisetty, H. Kirkici, D. L. Schweickart, "Partial vacuum breakdown of helium at 20 khz for point to-plane geometry", Power Modulator Symposium 2004 and 2004 High-Voltage Workshop, pp. 38-41, 2004.
- [6] K. Koppisetty, H. Kirkici, D. L. Schweickart "Optical emission characteristics of helium breakdown at partial vacuum for point to point geometry", IEEE-CEIDP Annual Report, pp. 47-50, 2005.