

A 3.5 to 12 Micron “Dualband” Spectrometer for Generic UAVs

Dr. Paul D. LeVan

Air Force Research Laboratory / Space Vehicles Directorate
3550 Aberdeen Ave SE
Kirtland AFB, NM 87117-5776 USA

paul.levan@kirtland.af.mil

ABSTRACT

A new approach is described for obtaining spectral imagery over a broad range of infrared wavelengths, with high efficiency, and with a single grating element and focal plane array. The approach represents a simplification and mass reduction over the traditional approach involving multiple focal plane arrays, dispersing elements, and optical beamsplitters. The new approach has significant advantages for space-based and airborne hyperspectral imagers operating in the infrared over a broad range of wavelengths (e.g., MWIR & LWIR), where the reduction in cryo-cooled mass relative to the multi-channel approach translates into noteworthy savings in volume and cryo-cooling requirements. Overlapping grating orders are focused onto a multi-waveband focal plane array in order to create spectral images of a scene simultaneously in multiple wavelength regions. The blaze of the grating is chosen so that all spectral orders are dispersed with high grating efficiency. Such an approach extends the spectral range of dispersive spectrometers to several octaves of wavelength, while preserving the compact packaging and cryogenic requirements of conventional (one octave) instruments. We conclude with a description of a ground-based demonstration of an MWIR & LWIR embodiment of the concept.

1.0 INTRODUCTION

Here we describe a 10 kg class sensor payload that would collect spectral imagery in the MWIR and LWIR. This “dualband” configuration is a specific case of a more general, multi-waveband approach for spectral image collection involving a single grating element and a multi-waveband, infrared focal plane array (FPA) [1]. Because the instrument is a slit spectrometer, the data acquisition method is conventional, with the slit oriented perpendicular to the direction of scan motion composed of the UAV ground speed and motion of a 1-D scan mirror or sensor gimbals providing limited amounts of back scanning. At any single instant of time, a full MWIR & LWIR spectrum is collected for each of 256 ground sample point along the optical projection of the slit onto the ground scene. A cryocooling approach is compatible with the 10 kg payload package, since the mass, efficiency, and reliabilities of cryocoolers having the required operating temperature and capacity have improved with time. The alternative of expendable cryogen (e.g., liquid nitrogen) may be appropriate for a testing phase but inconvenient for operators as part of their pre-launch, UAV servicing protocol.

A prototype instrument of this type, using a combination of liquid helium and liquid nitrogen in a pour-fill Dewar, is described below. This choice assured “overkill” in cooling capacity, thereby being more forgiving of underestimated cooling loads and lower-than-expected operating temperature requirements of the new generation of infrared focal plane array technology that is employed. It was understood from the onset that a

LeVan, P.D. (2005) A 3.5 to 12 Micron “Dualband” Spectrometer for Generic UAVs. In *Advanced Sensory Payloads for UAV* (pp. 20-1 – 20-14). Meeting Proceedings RTO-MP-SET-092, Paper 20. Neuilly-sur-Seine, France: RTO. Available from: <http://www.rto.nato.int/abstracts.asp>.

Report Documentation Page

*Form Approved
OMB No. 0704-0188*

Public reporting burden for the collection of information is estimated to average 1 hour per response, including the time for reviewing instructions, searching existing data sources, gathering and maintaining the data needed, and completing and reviewing the collection of information. Send comments regarding this burden estimate or any other aspect of this collection of information, including suggestions for reducing this burden, to Washington Headquarters Services, Directorate for Information Operations and Reports, 1215 Jefferson Davis Highway, Suite 1204, Arlington VA 22202-4302. Respondents should be aware that notwithstanding any other provision of law, no person shall be subject to a penalty for failing to comply with a collection of information if it does not display a currently valid OMB control number.

1. REPORT DATE 01 MAY 2005	2. REPORT TYPE N/A	3. DATES COVERED -	
4. TITLE AND SUBTITLE A 3.5 to 12 Micron Dualband Spectrometer for Generic UAVs		5a. CONTRACT NUMBER	
		5b. GRANT NUMBER	
		5c. PROGRAM ELEMENT NUMBER	
6. AUTHOR(S)		5d. PROJECT NUMBER	
		5e. TASK NUMBER	
		5f. WORK UNIT NUMBER	
7. PERFORMING ORGANIZATION NAME(S) AND ADDRESS(ES) Air Force Research Laboratory / Space Vehicles Directorate 3550 Aberdeen Ave SE Kirtland AFB, NM 87117-5776 USA		8. PERFORMING ORGANIZATION REPORT NUMBER	
9. SPONSORING/MONITORING AGENCY NAME(S) AND ADDRESS(ES)		10. SPONSOR/MONITOR'S ACRONYM(S)	
		11. SPONSOR/MONITOR'S REPORT NUMBER(S)	
12. DISTRIBUTION/AVAILABILITY STATEMENT Approved for public release, distribution unlimited			
13. SUPPLEMENTARY NOTES See also ADM202032., The original document contains color images.			
14. ABSTRACT			
15. SUBJECT TERMS			
16. SECURITY CLASSIFICATION OF:			17. LIMITATION OF ABSTRACT
a. REPORT unclassified	b. ABSTRACT unclassified	c. THIS PAGE unclassified	UU
			18. NUMBER OF PAGES 47
			19a. NAME OF RESPONSIBLE PERSON

A 3.5 to 12 Micron “Dualband” Spectrometer for Generic UAVs

cooled, higher sensitivity slit spectrometer would result in a decrease in photon rate on the FPA relative to broad-band imaging requirements, and require lower FPA dark currents and operating temperatures to realize the ultimate sensitivity levels. A flight instrument would probably make use of the new levels of cryocooler performance now available, with the cryocoolers supplying the cooling requirement of both the cooled spectrometer assembly (through a thermal resistance) and the lower operating temperature of the FPA. See Table 1 for an estimate of these cooling requirements.

Table 1: Cryocooling “heat lift” estimates

Sensor Assembly Component	Power dissipation (W), (E)lectrical, (C)onductive, & (R)adiative
Focal Plane Array (FPA) @ 60 K	0.35 (E) & 0.6 (C)
Spectrometer @ 150 K, via thermal resistance	0.75 (C) & 1.9 (R)
Total estimated cryocooler cooling	3.6 Watt @ 60 K

1.1 Utility

A full understanding of the utility of “Mid-Long” (or MWIR & LWIR) hyperspectral imagery in the context of a future UAV payload would be facilitated by field testing. In the absence of such testing, the following general remarks are provided. Beginning first with a discussion of the utility in terms of “spectral matched filter” processing, the hyperspectral literature (see, for example, recent proceedings of the SPIE edited by Sylvia Shen [2]) is replete with discussions of mixtures, or a superposition, of basic spectra that comprise the overall, observed spectrum. The separation of these components often follows a Principal Components (PC) approach that breaks the observed spectrum down into the PC spectra, with the spectra rank ordered from strongest to weakest in terms of contribution. The “unmixed” spectra could be quickly compared with library spectra of various types, looking for matches within a certain range of agreement. It should be kept in mind that a slit spectrometer of the type described here produces spectra for each ground sample point along the slit, as the slit is scanned forward over the ground scene. From a processing standpoint, we are describing PC analysis for each of these ground sample points at a speed that must keep up with the motion of the slit. There may also be utility in the form of flagging abnormal spectral signatures; i.e., those not found in the library.

As an additional consideration of the utility, Mid and Long Wavelength (MWIR & LWIR) spectral imaging responds to the thermal emission from objects in the scene. The particular combination of mid-long is noteworthy for encompassing both the peak in thermal emission from room temperature objects (LWIR) as well as the peak of hotter ($300\text{ K} < T < 900\text{ K}$) objects (in the MWIR) associated with running engines, waste nuclear heat, and other heat sources. However, in addition to quantifying the temperature associated with these broad spectral distributions associated with greybody thermal radiation, Mid-Long spectral images also measure emissivity variations with wavelength associated with the surface material properties. For example, the mineral quartz in particulate form has a spectral feature near 9 microns that is differentiated in a particular class of disturbed and undisturbed soils [3].

A 3.5 to 12 Micron “Dualband” Spectrometer for Generic UAVs

Also, all MWIR spectra easily detect the atmospheric CO₂ feature near 4.3 microns; these and weaker atmospheric absorption features are typically removed multiplicatively (as part of the “atmospheric correction”) before attempting the un-mixing of target spectra described above. It’s no surprise that other gases along the line of sight to a background source of thermal emission are also detectable by virtue of their “infrared active”, rotational-vibrational transitions.

In summary, the prospects for spectral imaging aboard new generation, UAV platforms appear promising. However, testing of the concept against a specific class of target or gas effluents would be helpful in validating this conclusion. The motivating considerations for an instrument of this type are described next.

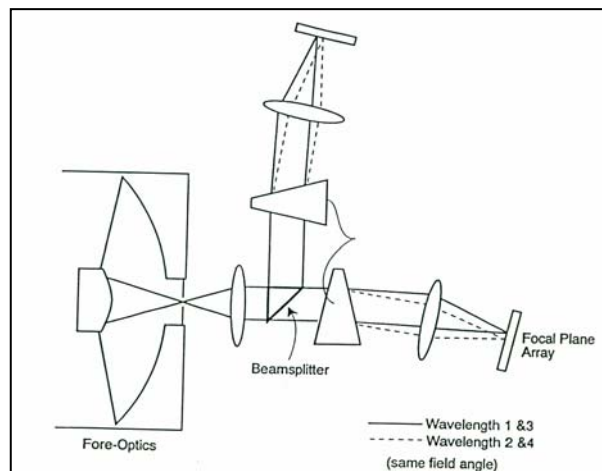

Figure 1: A “classical” two channel spectrometer.

2.0 CONCEPT

The challenges of multi-octave spectral imaging in the infrared with down-looking sensors are atmospheric (e.g., transmission windows) and instrumental in nature. One of the instrumental challenges is the preservation of high efficiency over a broad range in wavelengths, which for the MWIR and LWIR regions spans more than two octaves of wavelength. Both photovoltaic (PV) detector response and grating efficiency decrease at wavelengths shorter than the optimal values – so a grating-based spectrometer and FPA optimized for the LWIR would suffer from decreased grating efficiency and perhaps detector quantum efficiency in the MWIR. Even if the detector efficiency could be kept high at the shorter wavelengths, its important to realize that target signals in the MWIR are typically weaker than those in the LWIR, and compete unfavourably with the much higher dark currents associated with an LWIR cut-off wavelength. These efficiency losses typically drop below acceptable levels, and the traditional approach for overcoming them has been a multi-channel configuration with grating (or prism) and FPA “pairs”. These channels are optimized for an approximate octave in wavelength, and share a common aperture and FOV through the use of optical beamsplitters, as shown in Figure 1 for two channels. Alignment of scene pixels in the two wavebands is never perfect; even with match pixel pitches, the various forms of misalignment in the two-channel approach are exceedingly

A 3.5 to 12 Micron “Dualband” Spectrometer for Generic UAVs

difficult to control. The use of a prism as the dispersion element also restricts the range of useful wavelengths to those for which the angular dispersion of the prism is acceptable.

Infrared focal plane arrays that image in two wavebands simultaneously (designated “dualband FPA”, hereafter) have been produced for broadband imaging applications. Noteworthy among their attributes is that spatial and spectral data is collected simultaneously, albeit in only two wavebands. Also noteworthy is that when PV detectors are employed for “Mid-Long” dualband FPAs, high quantum efficiency results in both the MWIR and LWIR, and the MWIR dark current is benign, thereby mitigating one of the two key efficiency losses identified above. We address next the nature of a grating-based, dispersive spectrometer with a multi-waveband FPA at its focus, as a generalization of what is now possible with the present dualband FPA availability.

Gratings are characterized by high efficiency in spectral regions near their “blaze wavelength”, and values of efficiency that decline rapidly below two-thirds of the blaze wavelength. This feature was mentioned above as one of two efficiency loss mechanisms affecting traditional multi-octave spectral imagers. Gratings also have the well-known property of providing multiple, overlapping orders. The existence of overlapping orders has traditionally been viewed as a liability for most applications, with the consequence that unwanted orders falling within the range of useable detector response need to be “blocked” with spectral filters. An example of this would be a LWIR grating spectrometer that disperses wavelengths from 8 to 14 microns across a two-dimensional FPA, with the grating operated in first order. The FPA might also respond to the second order spectrum from 4 to 7 microns that is dispersed over the same region of the FPA; a cryogenically cooled LWIR spectral filter with wavelength cut-on between 7 and 8 microns would then be used to block the unwanted 4 to 7 micron (and higher order) spectra.

However, there is an attractive feature about the higher grating orders that is relevant to our multi-octave spectral imaging concept. These higher orders enjoy the same peak wavelength efficiency as the first order. Specifically, a grating with blaze wavelength λ_B has similar efficiency at λ_B / n , where n is an integer. These higher order wavelengths are diffracted by the grating at the same angle, and lay on top of the first order spectrum. We therefore combine the advantage of overlapping grating orders with the capability of multi-waveband FPAs to integrate spectra independently in the various orders, thereby achieving a solution that achieves efficient multi-octave spectral imaging. The properties of this new instrumental concept, used with a dualband FPA, are described in the following section.

2.1 The Dual-Octave Spectrometer Concept – Atmospheric Considerations

The wavelength regions from 3.5 to 6 and 7 to 12 appear to work well for a dualband FPA having short waveband cut-off and long waveband cut-on (hereafter designated “spectral crossover”) in the 5-7 micron region, as explained below. Strong atmospheric absorption features occur near 4.3 microns (CO_2) and from roughly 5.5 and 7 microns (H_2O , N_2O , & CH_4). A LWIR cut-off wavelengths approaching 12 microns has levels of dark current lower than that of the signal photocurrents expected for this application (see Section 2.3); longer cut-off wavelengths having much higher levels of dark current would be problematic. The corresponding MWIR (second order) spectrometer cut-off is 6 microns; the MWIR response of the dualband FPA therefore needs to extend to 6 microns or longer. We choose to initiate the onset of LWIR spectral coverage at 7 microns rather than at the 6-micron edge of the MWIR coverage. This allows the troublesome wavelengths near the FPA “spectral crossover” (shown schematically in Figure 2) to be dispersed off the FPA, thereby avoiding high levels of spectral crosstalk. The resulting capability can be described as having good coverage of the LWIR atmospheric “window” (omitting, however, the high transmission region between 12 and about 13.3 microns). The capability also includes a significant fraction of relatively good transmission

from approximately 3 to 4.2 microns, as well as coverage of the lower transparency region longward of about 4.6 microns. Poor dualband FPA performance in the vicinity of the “spectral crossover” does not impact overall system performance, if the crossover is restricted to the atmospheric absorption region between roughly 5.5 and 7 microns.

2.2 General Comments on Dualband Infrared Focal Plane Arrays

Dualband FPAs have been realized for various “waveband pairs”, including MWIR-MWIR (with spectral crossover near 4.3 microns), MWIR-LWIR, and LWIR-LWIR (with spectral crossover near 8 microns). The discussion that follows relates to dualband FPAs of photovoltaic detectors, whose broad wavelength coverage is amenable to dispersive spectral imaging. These FPAs are similar in operation to single waveband FPAs, but each pixel is a site for dualband detection. The shorter waveband material absorbs shorter wavelength photons, and transmits longer wavelength photons to the (deeper) longer waveband. Typically, photocurrents for both wavebands are injected separately into the detector multiplexer circuit, and integrated at separate charge storage sites within the multiplexer. For dualband FPAs fabricated for “simultaneous” operation, both photocurrents are integrated during the same frame time, and typically during the same integration time. In “sequential” operation, one waveband is integrated during one frame time, the other waveband during the next frame time, so that frames of data from the FPA are “waveband interlaced”. Waveband-specific values of integration time are easy to implement in the sequential configuration, but simultaneity is no longer possible. Details on the growth and fabrication of the dualband IRFPAs can be found in the literature [4, 5].

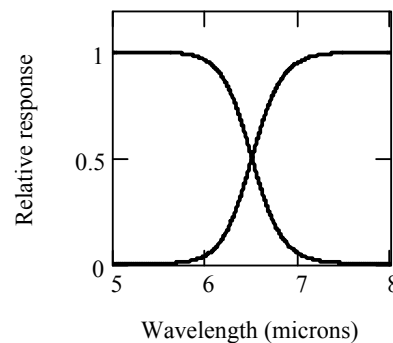

Figure 2: Schematic of the “spectral crossover” for a dualband FPA. As the response of the shorter band is decreasing, that of the longer waveband is increasing.

2.3 Performance Modelling

We have developed a MathCadTM model for our dualband spectrometer concept that operates over the wavelengths from 3.5 to 6 and 7 to 12 microns. The objectives of this model are to estimate signal photocurrent for the down-looking case as a function of wavelength and for first and second order grating efficiencies (Figure 3), and compare this with total noise (also as a function of wavelength). The signal photocurrent estimate also provides a useful comparison with FPA dark current (shown in Figure 4), and both lead to an estimate for FPA integration times that result in appropriate levels of “filling” the FPA charge integration wells. The scene is typically modeled as a 295-Kelvin greybody having 0.9 emissivity, for the purpose of this estimate of baseline performance. Total noise (in “root-mean-square” electrons) is estimated

A 3.5 to 12 Micron "Dualband" Spectrometer for Generic UAVs

as a function of wavelength from photon noise arising from scene and optics emission, dark current noise, and FPA read-out noise. The calculations have proven useful for evaluating the compatibility of dualband FPAs with the spectrometer concept and for selected optical collecting areas and pixel fields of view. The resulting signal to noise ratios (SNR) are shown as a function of wavelength in Figure 5, for an effective F/4 beam imaged onto a FPA with 50 micron pixels. (This corresponds to a 0.17-meter diameter primary mirror and 73-microradian pixel FOV, for example.) The integration time found for a 75% fill of the charge integration well at a wavelength of 11 microns (where the well fill time is a limiting factor due to the high photon rates at this wavelength) is about 10 milliseconds; this value of integration time would be compatible with FPA frame rates in the 50 to 100 Hz regime. The SNR is high except at the shortest wavelengths (Figure 5), where it suffers because of the relatively small number of signal photoelectrons integrated over the time selected for optimal LWIR well fill. A custom dualband FPA that allows selection of different (and optimal) values of MWIR and LWIR integration times would lead to improved, shorter wavelength SNR.

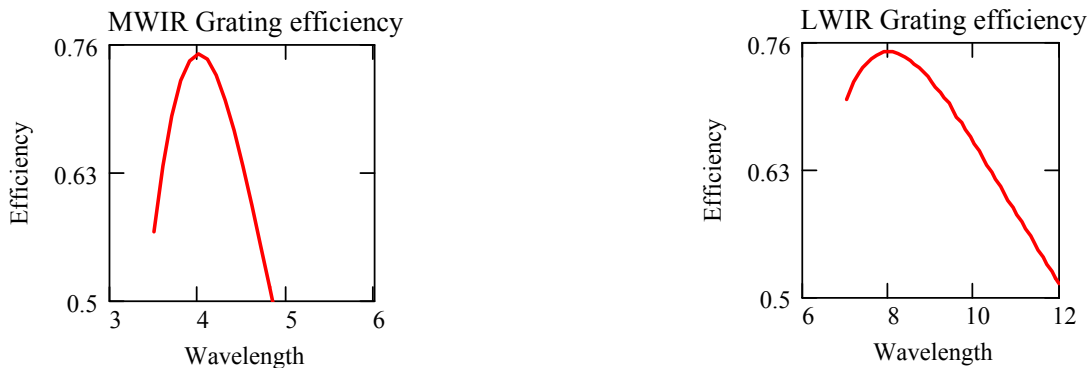

Figure 3: Calculated grating efficiencies. Grating has 8 micron blaze wavelength, 30 grooves per mm, and a 6.9° blaze angle.

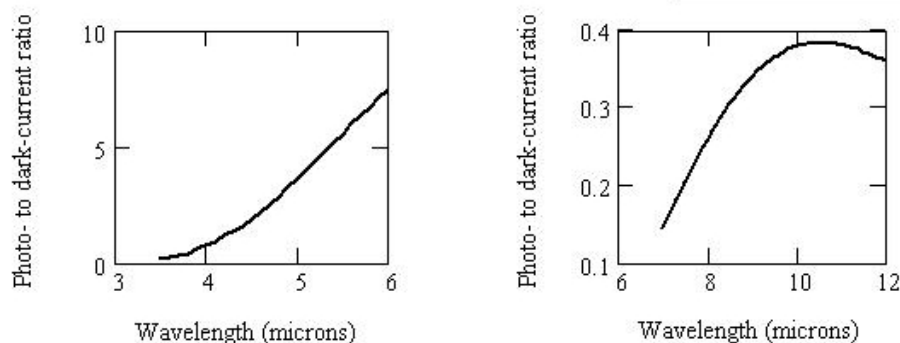

Figure 4: Photocurrent to dark current ratios, calculated as a function of wavelength.

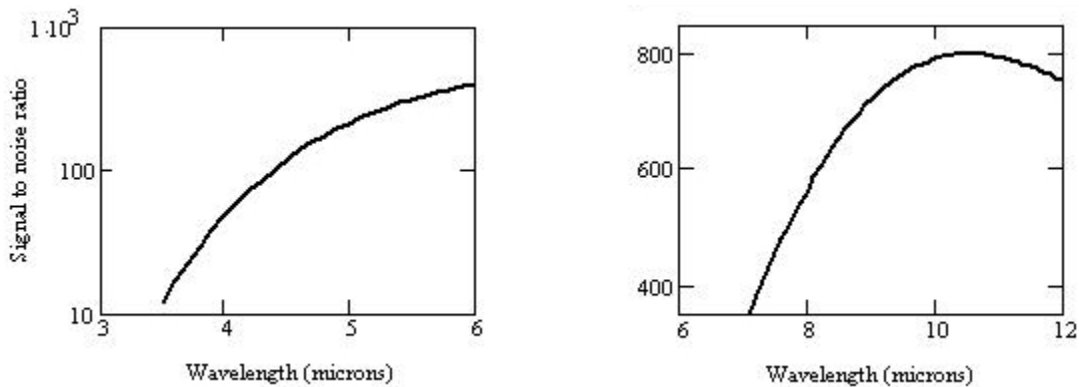

Figure 5: Calculated signal to noise ratios; 10 millisecon. integration time. Other details are described in text.

3.0 GROUND DEMONSTRATION HARDWARE & CALIBRATION CONSIDERATIONS

We considered salient features of relatively low cost “proof of concept” hardware for the dualband spectrometer. We envisioned a pour-fill Dewar to meet the cooling requirements of both the dualband FPA at a temperature near 40-60 Kelvin (for acceptably low levels of dark current) and the cooling of the spectrometer optics up to and including the spectrometer slit. A combination liquid helium (LHe) and nitrogen (LN₂) Dewar with a temperature controlled stage for the FPA (and having selectable thermal resistance between the stage and the LHe work surface) meets these requirements. The spectrometer slit would be at the focus of an infrared camera lens mounted external to the Dewar. The camera lens would image over a broad (MWIR to LWIR) range of wavelengths. A commercially available electronics package for operating the FPA, and acquiring, displaying, and storing data from the FPA, comprises the data acquisition system. A “dualband” display capability, i.e., one displaying the pair of spectral images, is required.

The Dewar, fabricated by IR Laboratories (Tucson, Arizona, USA), is a standard product modified for cubical liquid nitrogen (LN₂) radiation shields to accommodate the geometry of the spectrometer module. The Dewar also incorporates a cold stop at the exit pupil of the infrared camera lens. The spectrometer module (including two aspheric mirrors that serve to approximately collimate the beam diverging from the spectrometer slit onto a planar grating, the grating itself, and a single aspheric mirror used to image the dispersed radiation onto the FPA), was assembled, aligned, and integrated into the Dewar by SSG Inc. (Wilmington, Massachusetts, USA). The measured root-mean-squared wavefront error was less than 0.1 across the field-of-view for the entire waveband of interest. The ensquared energy (or fraction of energy from a particular field point falling within the area of a square, 50 micron pixel) is greater than 50% across the entire field-of-view, for all wavelengths. This design has a modulation transfer function within 15% of the diffraction limit (at the Nyquist frequency). A long (400 mm) focal length, infrared camera lens optimized for wavelengths between 3 and 12 microns provides the basis for the spectrometer design. The F/2.34 focus of the camera lens is imaged onto the spectrometer slit; the spectrometer magnification then results in an F/4 beam imaged onto the FPA. For the 400 mm focal length of the camera lens combined with a x1.7 spectrometer magnification for an effective focal length of 684 mm. The resulting pixel field of view is 73 microradians. Existing FPA drive

A 3.5 to 12 Micron “Dualband” Spectrometer for Generic UAVs

and data acquisition electronics have been modified to operate a 320x256 dual-band FPA, having wavelength cut-offs near 8 and 11 microns, and developed by DRS Infrared Technologies (Dallas, Texas, USA). The components are shown in Figure 6.

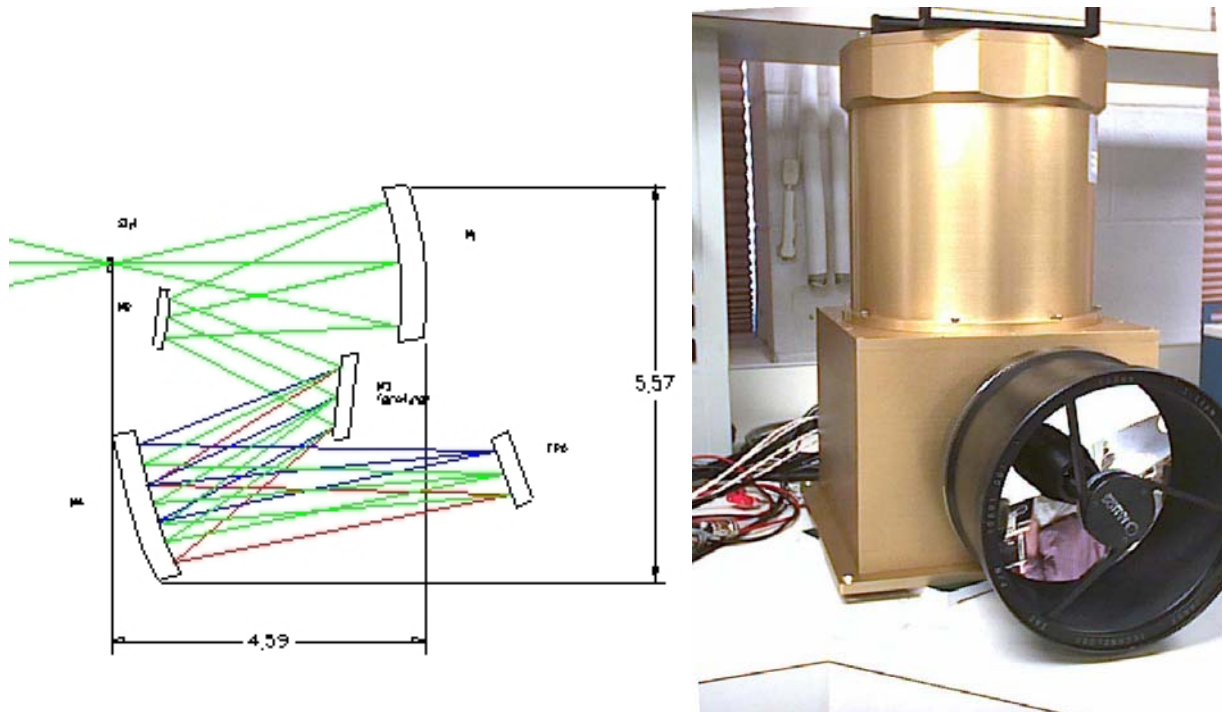

Figure 6: On the left, spectrometer sketch shown with an F/2.34 beam entering the slit from the left. Dimensions are in inches. On the right, IR camera lens shown mounted external to the Dewar.

A novel room temperature technique was demonstrated for the alignment of the spectrometer assembly to the sensor assembly. A read-out integrated circuit (ROIC) identical to that used with the dualband FPA was located in the sensor in place of the actual FPA. This “bare ROIC”, with no detector material attached, responds to visible radiation. The SSG team was able to diffract higher grating orders (the ninth through fifteenth orders of HeNe laser light) through the spectrometer assembly, and allow it to fall on the ROIC at measurable locations. This procedure allowed for initial, room-temperature alignment corrections to be made.

In addition to the pixel gain and offset corrections typically included as part of the commercial data acquisition system, a provision for spectral image corrections will also be required. These corrections include wavelength-dependent variations in instrumental transmission and FPA response that can be determined by observing a laboratory blackbody source. Finally, if the system is used to observe sources through long atmospheric path lengths, provisions for a spectral “atmospheric correction” would be required. Some of these calibration approaches are investigated below.

3.1 Analysis of Spectral Images Obtained with Ground Demonstration System

The level of calibration effort typically determines the quality of the data products for a down-looking hyperspectral application as described here. The dualband imaging spectrometer described above allows for

A 3.5 to 12 Micron “Dualband” Spectrometer for Generic UAVs

the exploration of various calibration issues. We were motivated by the knowledge that broadband infrared imagers (as opposed to spectral imagers) are effectively calibrated with out-of-focus radiation on the FPA at two differing flux levels that compensates for pixel response non-uniformity and dark current variations (hereafter referred to as NUC for non-uniformity correction). We sought to determine the efficacy of such an approach for the dualband spectrometer, bearing in mind the spectral dependence of the radiation dispersed over the FPA. Our approach was to use two extreme blackbody temperatures to define the upper and lower calibration levels, and to use an intermediate blackbody temperature as a test case, by calibrating its spectral image and comparing it with the theoretical spectral energy distribution. By performing this test, we are able to assess the efficacy of calibration and identify any anomalies associated with the dualband spectrometric approach.

Full details on this calibration approach have been published [6]. In summary, a simple extension of the approach used for a broadband infrared imager to the continuum of wavelengths of a spectral imager is found to be applicable, specifically,

$$F_{\lambda} = F_{\lambda}^{(L)} + [(F_{\lambda}^{(H)} - F_{\lambda}^{(L)}) / (S_i^{(H)} - S_i^{(L)})] (S_i - S_i^{(L)}) \tag{1}$$

where $S_i^{(L)}$, S_i , and $S_i^{(H)}$ are the signals for the i 'th pixel resulting for the low, "unknown", and high blackbody temperatures respectively. $F_{\lambda}^{(L)}$ and $F_{\lambda}^{(H)}$ are the assumed blackbody fluxes corresponding to the low and high temperature settings and at a wavelength corresponding to that of the i 'th pixel. However, complicating issues are introduced for cases involving a mismatch in dualband FPA wavelength cut-offs and the spectrometer wavelengths dispersed in the two orders; this should not be an issue for sensors fabricated as a result of dedicated FPA and spectrometer designs. Secondly, the recovered MWIR spectrum deviated from the expected shape and level of the 500 Kelvin blackbody spectral energy distribution (SED); this deviation was traced to FPA response to the third grating order, which was not blocked for the initial trials. A long-pass filter, with cut-on wavelength near 3.5 microns, is all that's required to compensate for this irregularity.

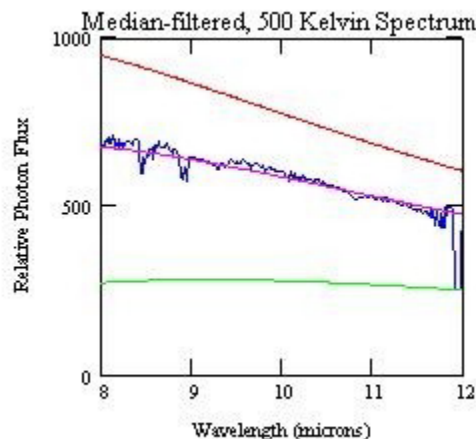

Figure 7: Calibration and program Blackbody distributions for LWIR. Instrumental spectral corrections include grating efficiency, FPA spectral response, and transmission of the Fresnel lens used for this test in place of the F/2.3 fore-optics.

A 3.5 to 12 Micron “Dualband” Spectrometer for Generic UAVs

We can also obtain useful information from the wavelength dependence in the instrumental correction factors. These correspond to the ratio $(F_{\lambda}^{(H)} - F_{\lambda}^{(L)}) / (S_i^{(H)} - S_i^{(L)})$ in Equation (1), where they are seen to be multiplicative factors in the conversion of the signal levels to calibrated flux levels. Basically, these multiplicative correction factors “boost” the signal level when the effects of decreasing instrumental transmission, grating efficiency, and detector response are present, and high values of the instrumental correction factor correspond to low values of instrumental efficiency. With regard to the MWIR instrumental correction, we note that optimal spectrometer performance is in the 4 micron region, close to the second order grating blaze wavelength, as expected.

3.2 Image Testing with a Distant Blackbody Source

A focus test was carried out on the system after receiving the Janos camera lens; up to that time the Fresnel lens had been used. As described previously, the camera lens images onto the (cooled) spectrometer slit. The long focal length (400 mm) of the camera lens limits the high imaging quality to object distances in excess of 100 meters, and for this reason a blackbody source was located near this distance for a system focus test. The “acquisition” of the 1-inch blackbody cavity in the spectrometer slit was accomplished with the spectrometer mounted on a tripod with azimuthal and elevation stages. The (object space) slit width of approximately 0.17 milliradians, compared with the angular subtense of the blackbody aperture (about 0.25 milliradians) shows that although tiny in angular extent, smaller blackbody apertures would be needed for a true point source.

For this test and its ease of execution, the spectrometer was cooled with liquid nitrogen (LN2), for which the MWIR but not the LWIR waveband is functional. The simplicity of the LN2 cool-down and the greater sensitivity of the MWIR channel to image quality (through decreased importance of diffraction) and de-focus, make this approach very attractive. Qualitatively, both the spatial and spectral response profile look encouraging (Figure 8) after the optimal lens focus adjustment is made. The FWHM of the spatial response is about 4 pixels or 0.3 milliradian for the (resolved) blackbody aperture. The measured profile of the strong atmospheric absorption feature of CO₂ near 4.3 microns faithfully reproduces the steeply-declining short-wavelength edge of the feature, indicative of the high spectral resolution of the instrument. Here, the exchange of odd and even pixel signal outputs that was mentioned above was corrected for this display of the CO₂ profile.

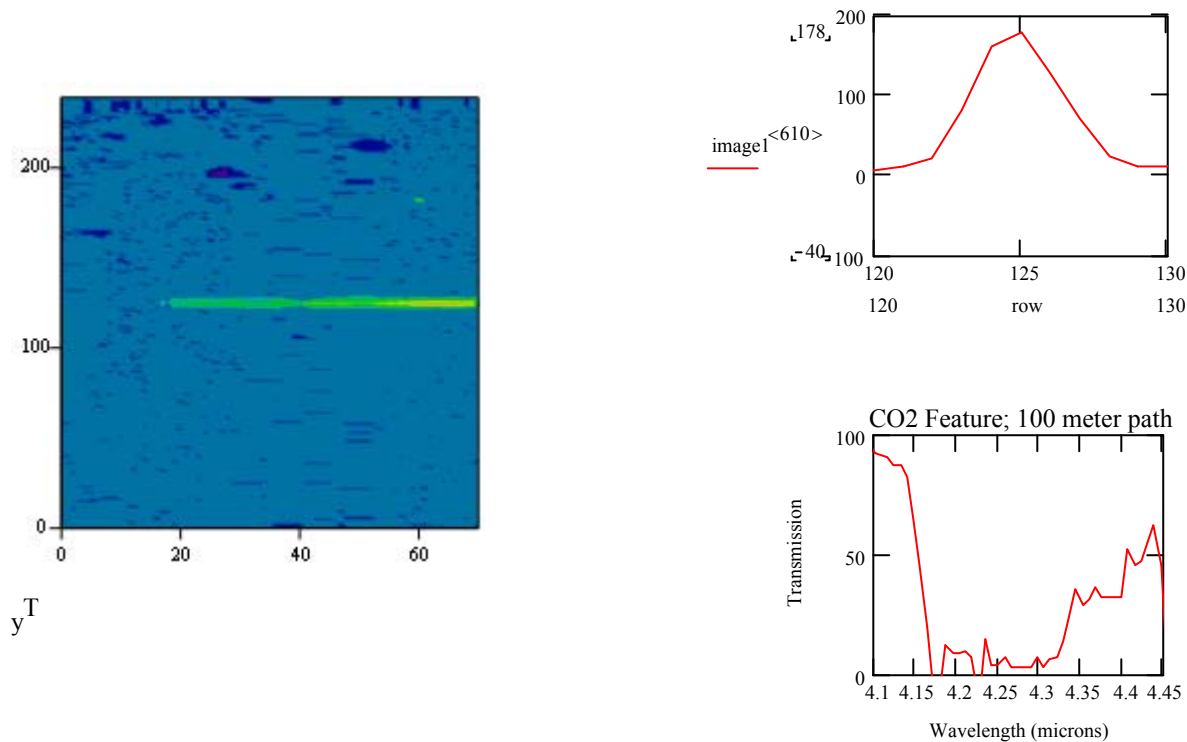

Figure 8: Spectral image of distant blackbody source, extracted CO₂ spectral profile, and extracted spatial profile. Unlike the case for Figures 7, non-uniformity corrections have not been implemented, and the wavelength calibration was accomplished with narrow-band filter measurements, rather than by more precise methods.

4.0 CRYOCOOLER VERSION OF THE INSTRUMENT

A mechanical cryocooler version of the instrument describe below is now underway. It employs a spectrometer module of identical optical prescription, employs newly-developed, ultra-compact FPA drive and data acquisition electronics, and demonstrates the cooling of both the spectrometer optics to 150 K and the FPA to less than 70K with a BEI (Sylmar, CA, USA) Model B5000EL cryocooler. The reliability of this model is quoted in terms of an MTF of greater than 10,000 hours. See Figure 9.

The cryocooler version of the instrument also interfaces with the 400 mm focal length, F/2.4 fore-optics. The total, “as built” mass of the entire assembly (cryocooler, foreoptics, vacuum vessel, and electronics) is ~15 kg without light-weighting of the base plate or vacuum vessel. Delivery of this novel instrument is expected in the June 2005 timeframe; its performance in terms of ground sampling is summarized in Table 2 for a generic UAV application. The results of Table 2 suggest that some back scanning (mirror or gimbals) might be required at lower altitudes, since dualband infrared focal plane arrays having 320x256 pixels have frame rate limitations below 120 Hertz, unless the number of FPA outputs is in excess of four.

A 3.5 to 12 Micron “Dualband” Spectrometer for Generic UAVs

Table 2: Ground sample distances and sample rates from moving aerial platform

UAV altitude (km)	GSD ¹ (m)	Sample rate ² (Hz)
3	0.22	152
7	0.51	65

- ¹Ground sample distance assume 73 microradian pixel field of view of the “as built” sensor
- ²Sample rate for full spectra for all 256 ground points along the spectrometer slit, assumes 120 km/hour ground speed

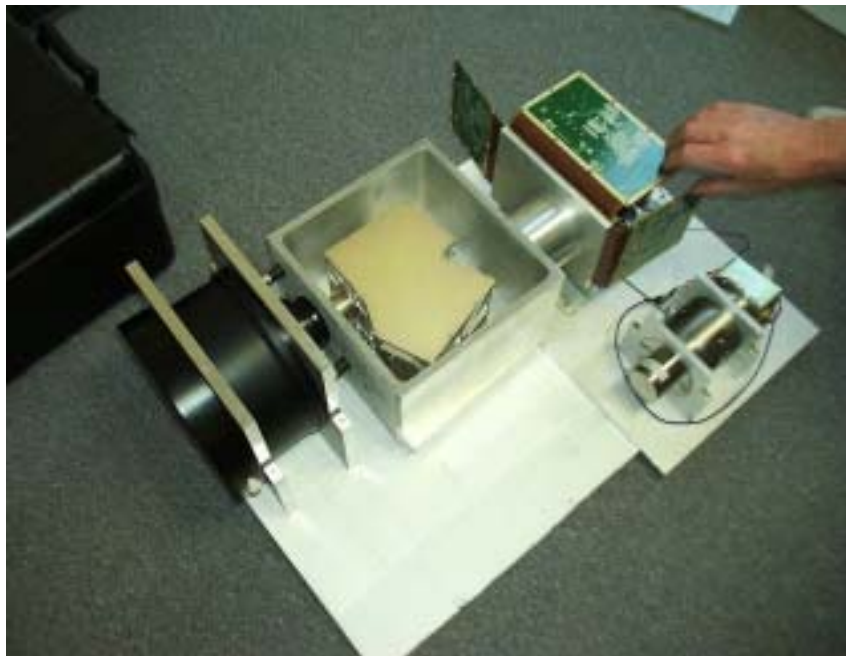

Figure 9: Integrated, cryocooler-based, dualband spectral imager. The 400 mm, F/2.3 fore-optics is visible on the left, the spectrometer module enclosed in its vacuum vessel in the center, and the FPA enclosure, cubical drive & data acquisition electronics (on flex connectors), and cryocooler on the right.

5.0 CONCLUSIONS

The utility of a dualband spectrometer for limited size, weight, and power applications, as for a UAV, was described. The utility of data product obtained with such a system was considered. The maturity of the concept was quantified with the discussion of a laboratory demonstration assembled to validate the “Dualband” Spectrometer concept. Analysis of collected data resulted in no insurmountable obstacles, with all the reported anomalies traceable to spectral contamination issues that are controllable with the selection of proper FPA cut-off wavelengths and specification of a long pass filter to block grating orders higher than second.

6.0 ACKNOWLEDGEMENTS

Jay Schwartz, Dave Driscoll, Jerzy Kocjan of SSG Precision Optronics, Inc. are acknowledged for SSG’s work in the design and fabrication of the cooled spectrometer module, as is Elliott Solheid of IR Laboratories for care in the design and fabrication of the Dewar. Nova Sensor (Solvang, California, USA) was responsible for much of the new cryocooler implementation.

REFERENCES

- [1] T. D. Maestas & P.D. LeVan (2002). *Novel, Three-Octave, Infrared Hyperspectral Imaging with a Single Multi-waveband FPA*, in *Imaging Spectrometry VIII*, Sylvia S. Shen, Editor, Proceedings of SPIE Vol. 4816, pp. 363-371.
- [2] Shen, Sylvia, Editor, Proceedings of SPIE (2004) Vol. 5546, pp.1-438; (2004) Vol 5425, pp.1-688; (2004) Vol. 5159, pp.1-416; (2003) Vol. 5093, pp.1-792.
- [3] Arnold C Goldberg, Theodore Fischer, Zenon I Derzko, Parvez N Uppal, Michael L Winn (2002). *Development of a dual-band LWIR/LWIR QWIP focal plane array for detection of buried land mines*, Proceedings of SPIE, Vol. 4721, pp. 184-195.
- [4] P. Mitra, S. L. Barnes, Francine C. Case, Marion B. Reine, P. O’Dette, R. Starr, Allen W. Hairston, K. Kuhler, M.H. Weiler, and B. L. Musicant (1997). *MOCVD of band-gap engineered HgCdTe p-n-N-P dual-band infrared detector arrays*, J. Electronic Materials, Vol 26, p. 482.
- [5] M. B. Reine, A. W. Hairston, P. O’Dette, S. P. Tobin, F. T. Smith, B. L. Musicant, P. Mitra, F. C. Case, (1998). *Simultaneous MW/LW Dual-Band MOVPE HgCdTe 64x64 FPAs*, in *IR Detectors and Focal Plane Arrays V*, Proceedings of SPIE Vol. 3379, pp. 200-212.
- [6] P.D. LeVan (2004). *A 3.5 to 12 Micron “Dualband” Spectrometer*, Optical Engineering, Vol. 43, No. 12, pp. 3045-3054.



A 3.5 to 12 Micron “Dualband” Spectrometer for Generic UAVs





A 3.5 to 12 Micron “Dualband” Spectrometer for Generic UAVs

**Dr. Paul D. LeVan
Air Force Research Laboratory
3550 Aberdeen Ave SE
Kirtland AFB, NM 87117-5776 USA
paul.levan@kirtland.af.mil**



Motivation & Relevance



- **Hyperspectral sensors operating in “emissive” spectral regime have potential to significantly reduce target false alarm rates found with panchromatic and multi-spectral imaging approaches**
- **MWIR & LWIR represent a broad range in wavelength (~ two octaves) that is challenging to implement, spectrally**
- **Size, mass, and power are key drivers for UAVs**



Dualband (MWIR & LWIR) Hyperspectral Imaging with Dualband Focal Plane Array



Traditional Approach for hyperspectral information MWIR and LWIR:

- Multi-channel configuration with dispersing element and FPA “pairs”
- Each channel optimized for an approximate octave in wavelength
- Share a common aperture and FOV through the use of optical beamsplitters

“Traditional”, multi-channel approach

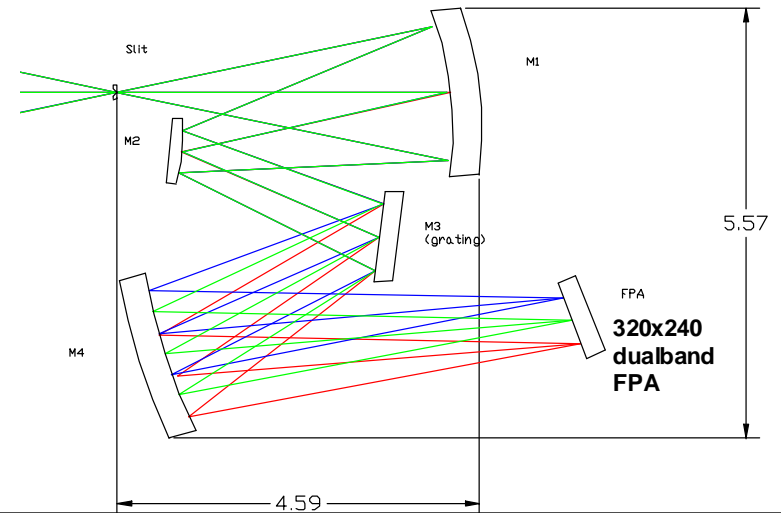
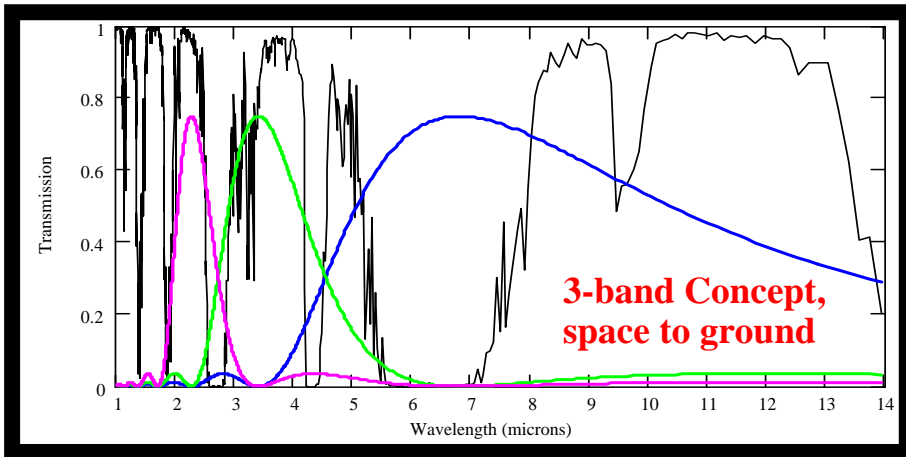
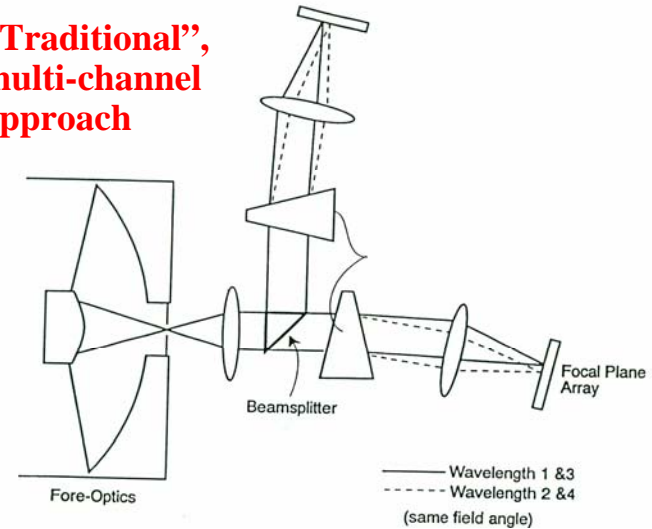

Requirements for next generation, UAV-based sensors: reduced power, volume and mass ³



Advantages of Dual Octave Spectrometer for Generic UAV



- **Lower Mass, Volume and Power consumption: single spectrometer, FPA and cryocooler provide performance equivalent to two channel design**
- **Elimination of beamsplitting optics**
- **Inherent registration of MWIR and LWIR data sets**

N.B., Specific design approach incorporates magnification, not attainable in Offner spectrometer



Payload Overview



- **Collects full MWIR & LWIR spectrum, instantaneously, for each of 256 ground sample points**
- **“10 kg class” sensor payload provides spectral imagery in MWIR & LWIR**
 - **Dualband version of general, multi-waveband approach for spectral image collection; employs single grating element and a dualband, infrared focal plane array (FPA)**
- **Cryocooling approach for simplicity of operations, pre-launch servicing**
- **Conventional data acquisition method: scanning, slit spectrometer, with slit oriented perpendicular to scan direction**



Payload Utility (“Mid-Long” hyperspectral imagery)



- “Spectral matched filter” processing using mixtures of basic spectra to produce observed spectrum
 - Comparison of “unmixed” spectra with library spectra of various types,
 - From a processing standpoint, we are describing Principal Components (PC) analysis for each ground sample point at a speed that must keep up with the motion of the slit.
 - Additional utility in the form of flagging abnormal spectral signatures; i.e., those not found in the library.
- Thermal emission from objects:
 - Room temperature objects (peak emission in LWIR)
 - Hotter ($300\text{ K} < T < 900\text{ K}$) objects associated with running engines, waste nuclear heat, and other heat sources (peak emission in MWIR)
- Variations in spectral emissivity
 - surface material properties
 - atmospheric absorption features; molecules with “infrared active”, rotational-vibrational transitions.

Field testing of concept against a specific class of target or gas effluents needed to test efficacy



Ground sample distances and sample rates from moving aerial platform



UAV altitude (km)	GSD¹ (meter)	Sample rate² (Hertz)
3	0.22	152
7	0.51	65

¹Ground sample distance assume 73 microradian pixel field of view, Prototype Instrument

²Sample rate for full spectra for all 256 ground points along the spectrometer slit, assumes 120 km/hour ground speed



Prototype Instrument in assembly phase

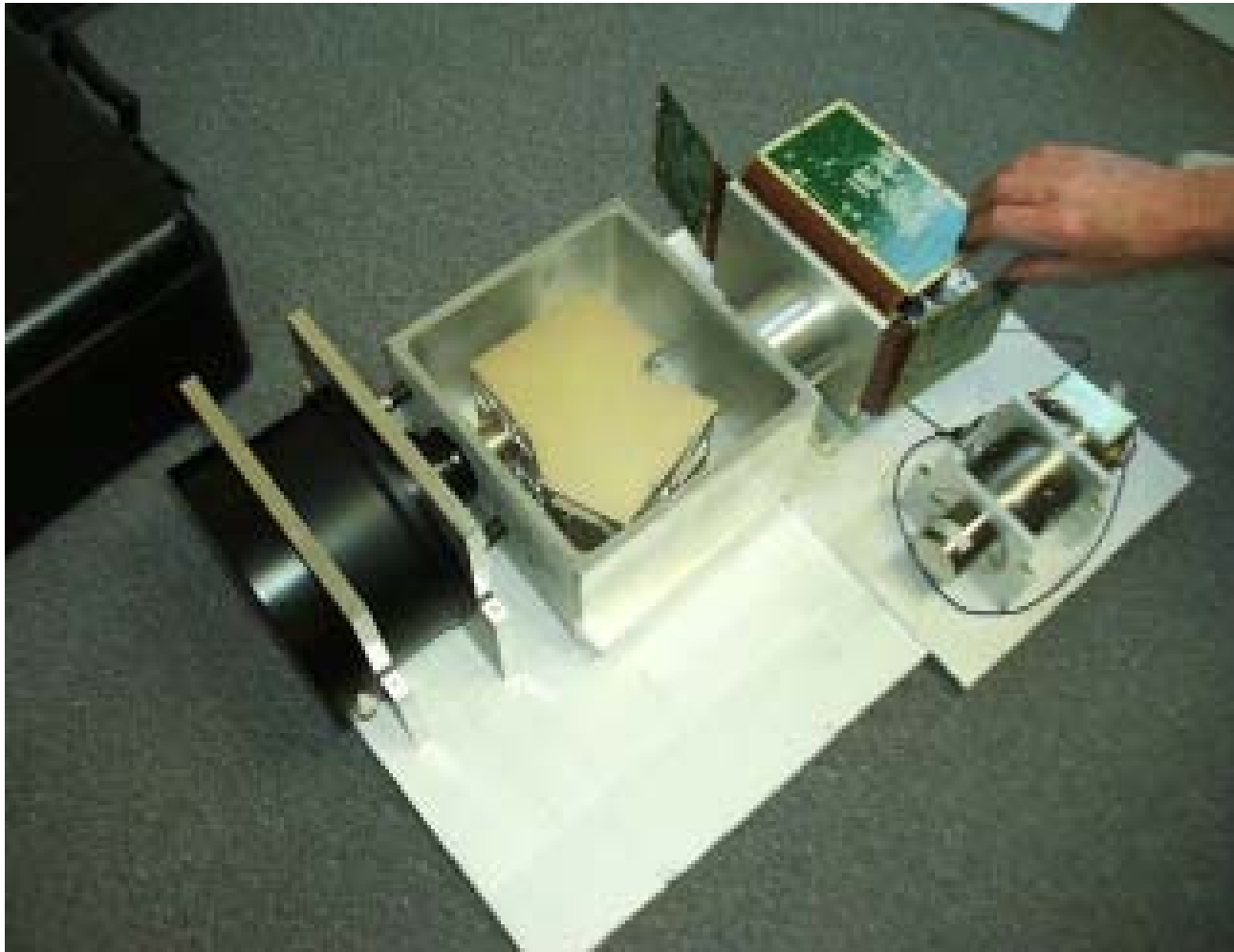



Sensor Mass Estimates – 16 kg “sensor head mass”



<i>Subsystem</i>	<i>Mass (kg)</i>	<i>Method</i>
spectrometer	1.15	built, x2 light weighting
cryocooler (includes control electronics)	5.0	standard product
vacuum vessel	4.4	Estimated; possibility for future light-weighting
Optical bench/support plate	1.73	Aluminum, possibility for future light-weighting
Janos fore-optics (F/2.3, 400 mm focal length)	3	standard product
support electronics	.5	measured

- Total sensor head mass is approximately 16 kg, derived with multiple methods.

- Estimated total power requirements are 148 watts at 28-volt supply voltage (25 watts at 28 volts supply estimated for camera electronics, and 120 watts at 28 volts supply estimated for the BEI B5000EL8 cryocooler).



Cryocooling “heat lift” estimates (Prototype Instrument)



Sensor Assembly Component	Power dissipation (W), (E)lectrical, (C)onductive, & (R)adiative
Focal Plane Array (FPA) @ 60 K	0.35 (E) & 0.6 (C)
Spectrometer @ 150 K, via thermal resistance	0.75 (C) & 1.9 (R)
Total estimated cryocooler cooling	3.6 Watt @ 60 K



Performance Modeling



- ***MathCad™ Modeling***
 - Useful calculations for evaluating the compatibility of dualband FPAs with the spectrometer concept, for selected optical collecting areas and pixel fields of view.
- ***Objectives***
 - Estimate signal photocurrent that arises from an example scene, and compare with total noise. Predict SNR as a function of wavelength.
- ***Scene***
 - 295 Kelvin greybody
 - 0.9 emissivity
- ***Total noise*** (in rms electrons)
 - Photon noise from both scene and optics emission
 - Dark current noise
 - FPA read-out noise



Grating Efficiency



- High efficiency near grating “blaze wavelength” (λ_B)

(2nd order)

MWIR Grating efficiency

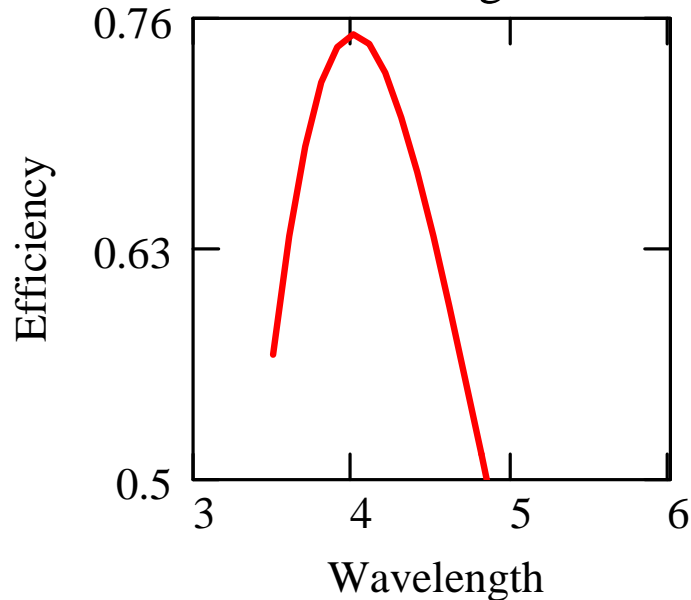

(1st order)

LWIR Grating efficiency

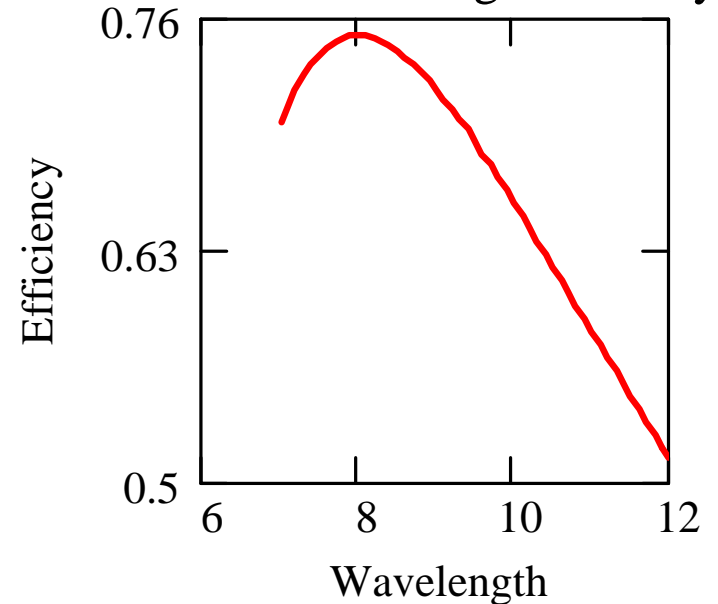

- Efficiency declines rapidly below $\sim 4/5\lambda_B$

- Efficiency declines rapidly below $\sim 2/3\lambda_B$

Overlapping grating orders: high grating efficiencies in key transmission windows in MWIR & LWIR



Signal Photocurrent, 50 Kelvin



F/4 beam imaged onto a FPA with 50 μm pixels

MWIR

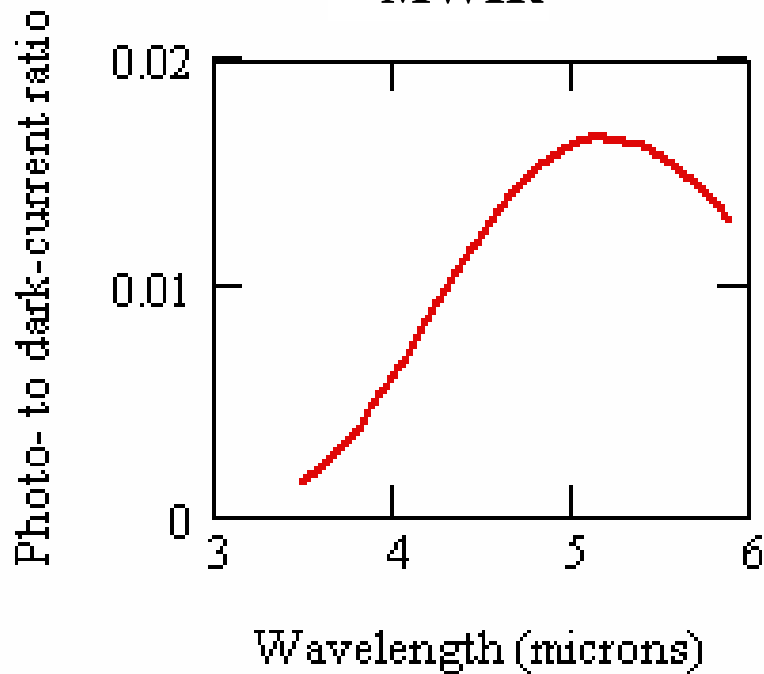

LWIR

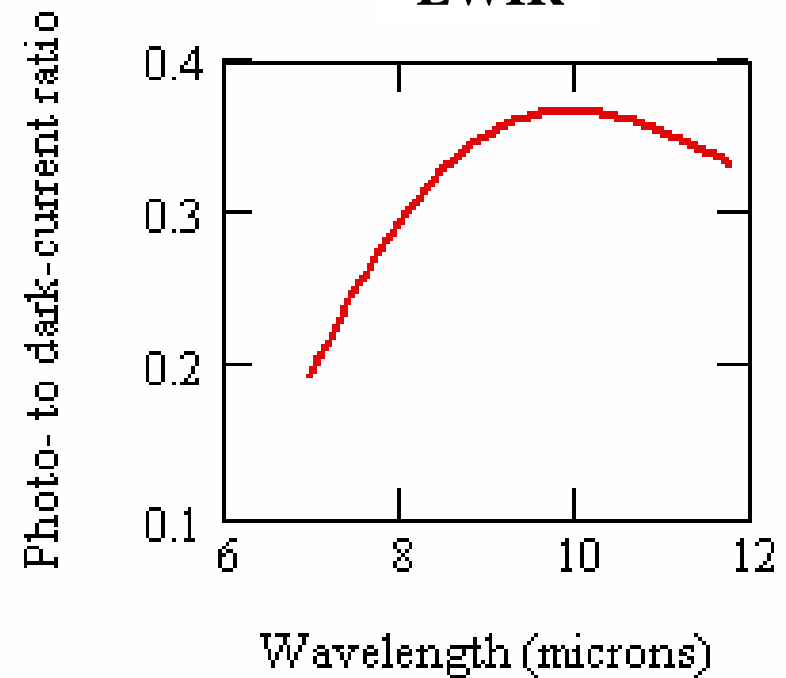

- **Signal Photocurrent Estimate**
 - Provides a useful comparison with FPA dark current
 - Leads to an estimate for FPA integration times

- **Integration time – 12.7 ms**
 - 75% fill of the charge integration well at a wavelength of 11 μm
 - compatible with FPA frame rates in the 50 to 100 Hz regime



Signal-to-Noise Ratios (SNR)



F/4 beam imaged onto a FPA with 50 μm pixels

MWIR

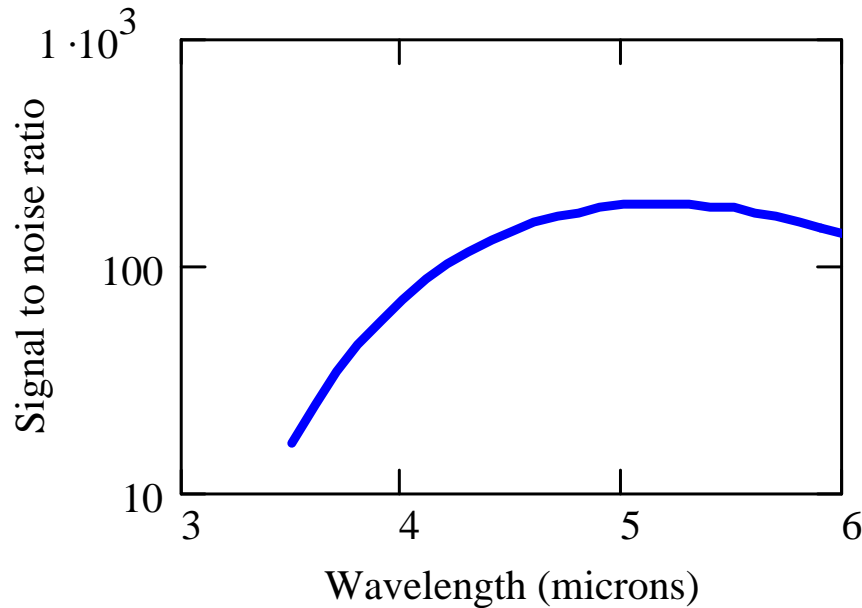

LWIR

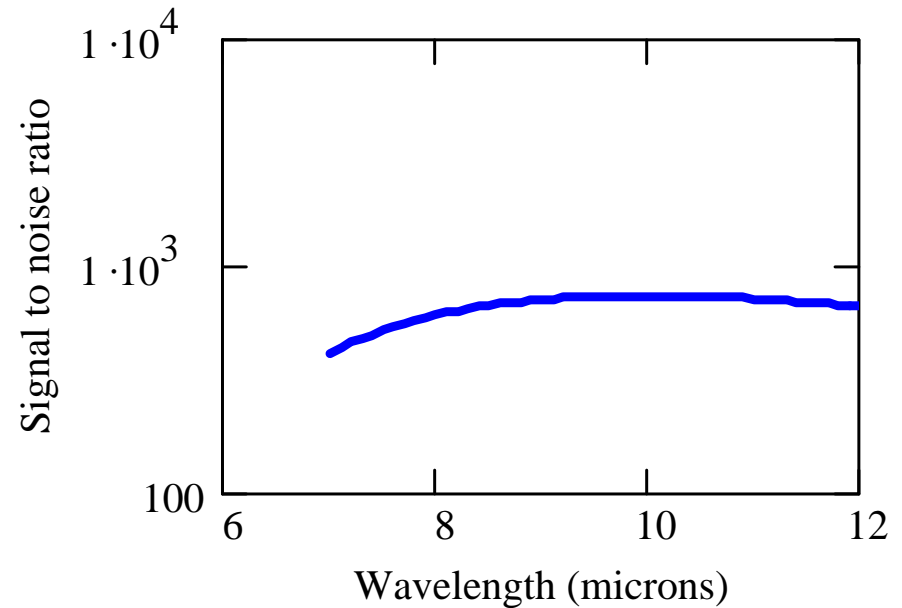

- **SNR is high except at the shortest wavelengths, where a relatively small number of signal photo-electrons are integrated over the time selected to preclude saturation in the LWIR**



Spectrometer Design



Dualband focal plane array – Background Information



- Shorter waveband material absorbs shorter wavelength photons, and transmits longer wavelength photons to the (deeper) longer waveband
- “Simultaneous” operation
— both photocurrents are integrated during the same frame time, and over the same integration time

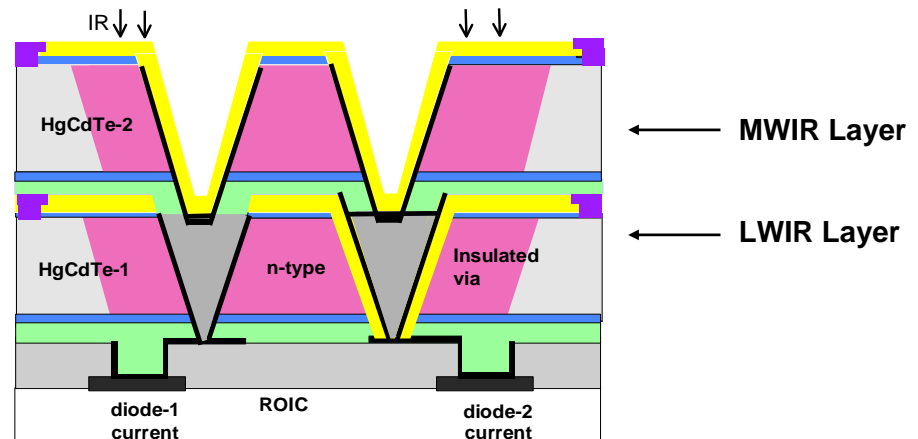
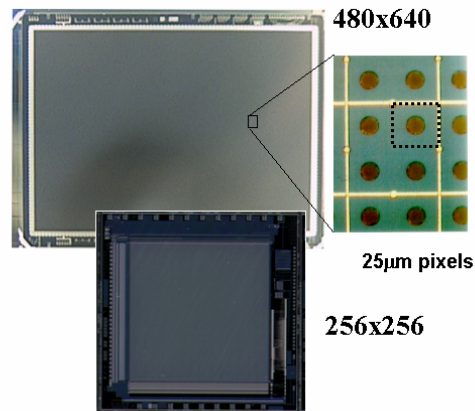



Fore-optics – An innovative, broad-waveband (3 to 12 μm) sub-system

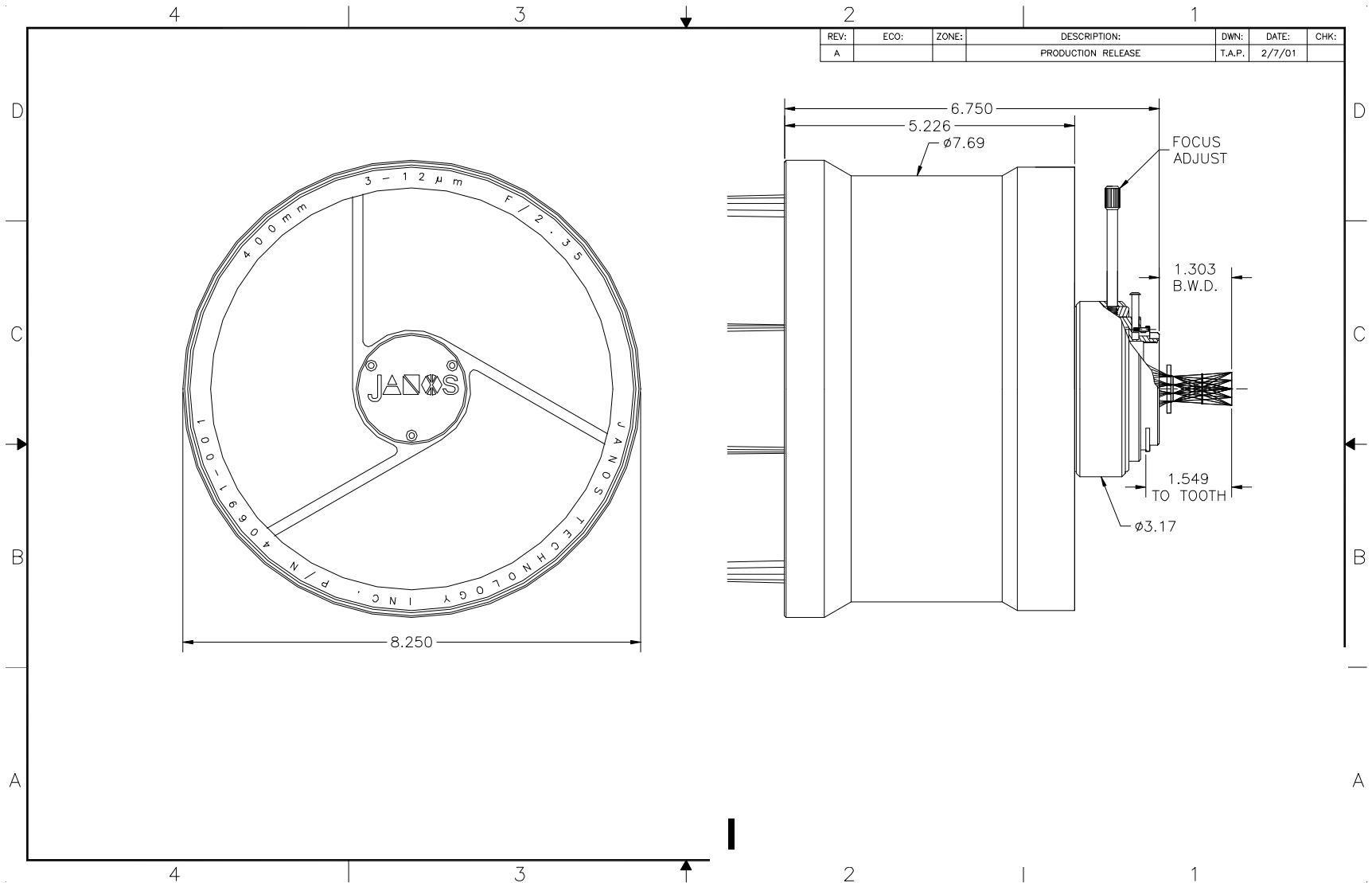



Spectrometer Design



- Design consists of three powered mirrors and a flat blazed grating*
 - High image quality
 - Low distortion at FPA
 - Design residuals < 0.1 waves RMS at 3 microns
 - Design incorporates magnification
 - F/2.35 at slit and f/4 at FPA
 - Compact size

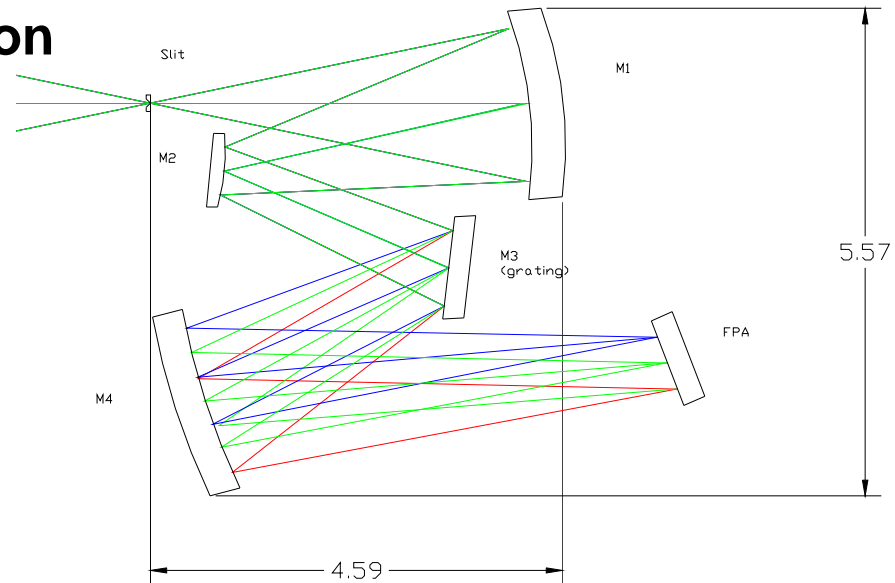

*Flat grating is replication of off-the-shelf grating

- Compatible with cryogenic operations



Concept avoids most of dualband FPA crosstalk near “spectral crossover”



- **Crossover defined by cut-off of the shorter waveband, and the cut-on of the longer waveband**
- **This is spectral region is “dispersed off” FPA**
- **Crossover also restricted to an atmospheric absorption region from roughly 5.5 to 7 μm**

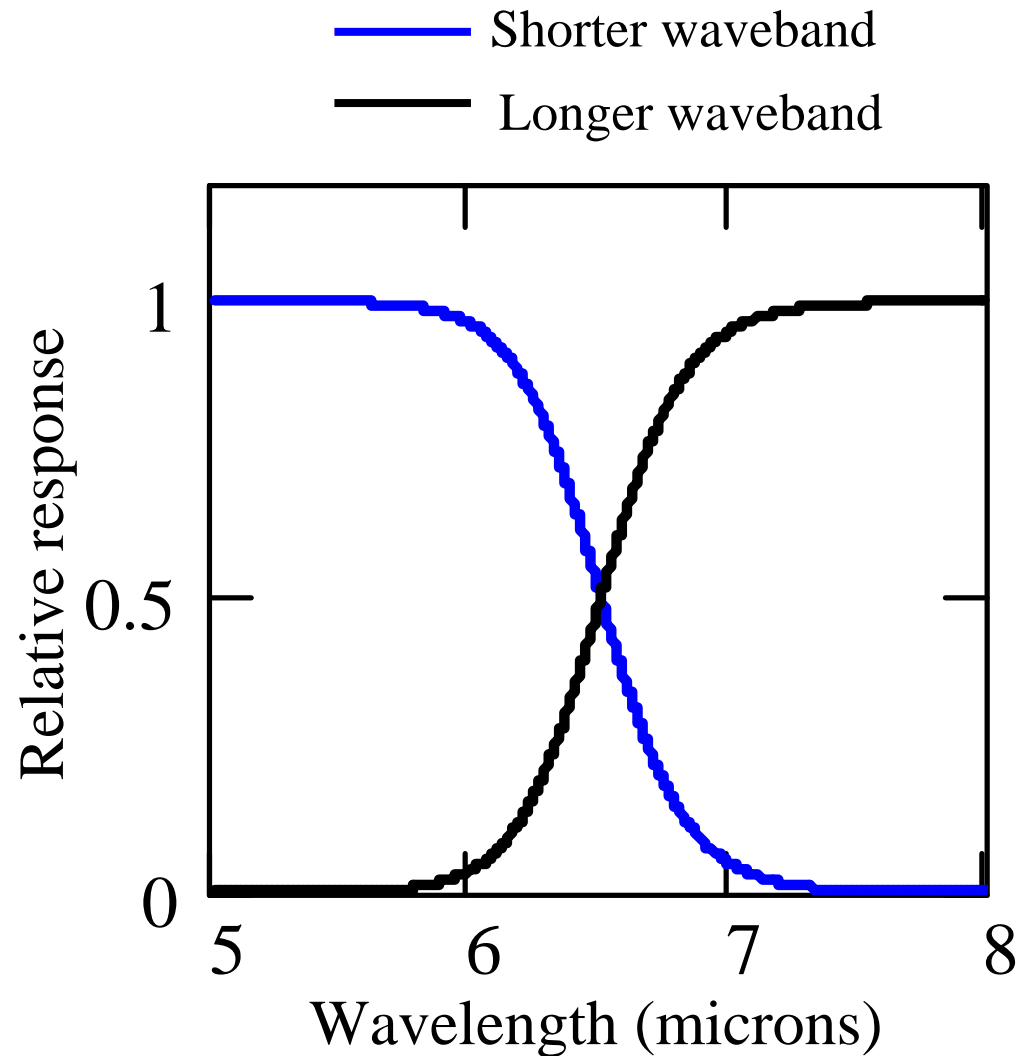



Dewar and Cooling Approach



Cryocooler Mounted to Lower Dewar Assembly

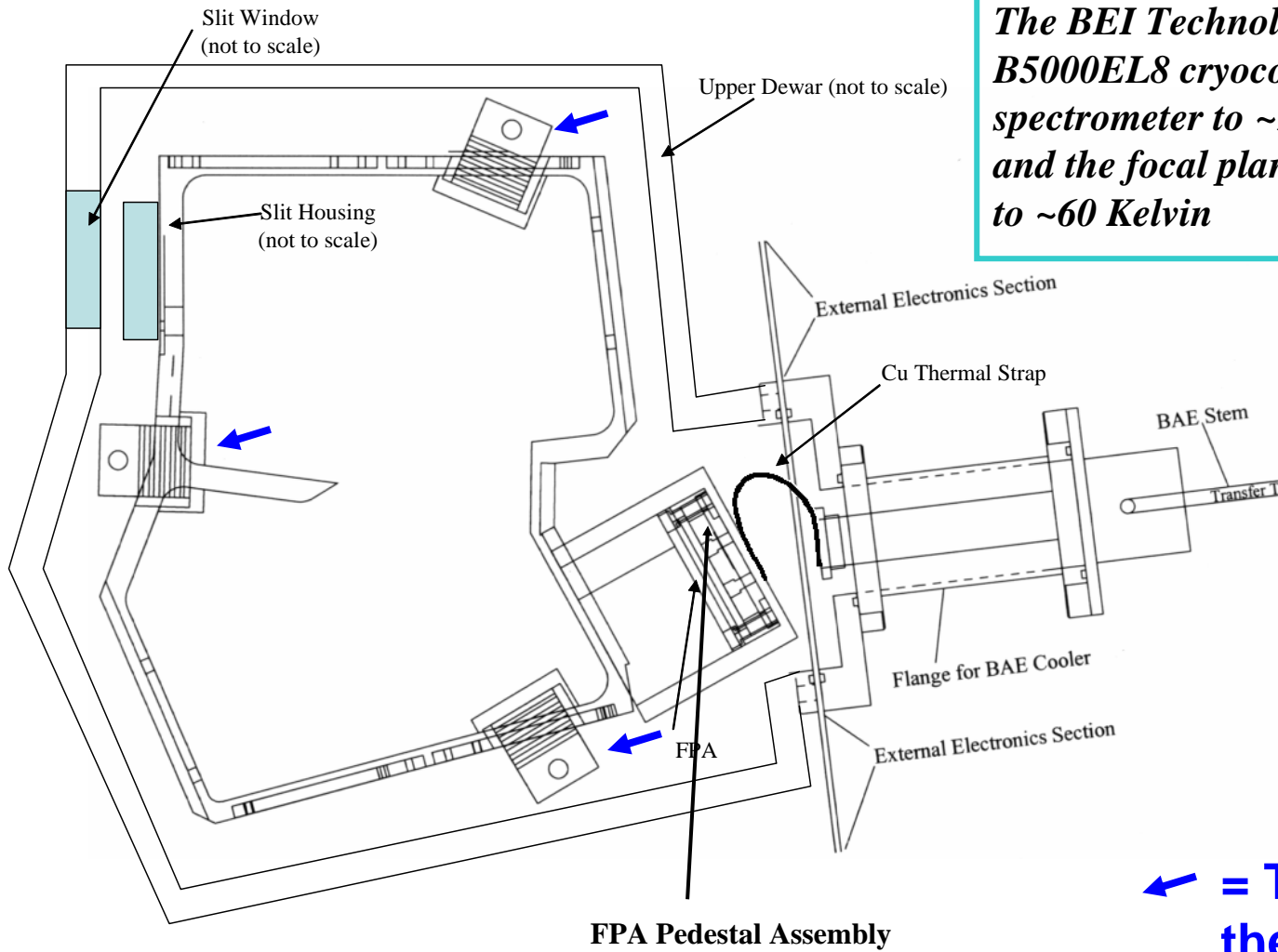

The BEI Technologies Model B5000EL8 cryocooler cools the spectrometer to ~150 Kelvin, and the focal plane array (FPA) to ~60 Kelvin

← = Titanium thermal isolators



FPA Pedestal Assembly Mechanically Mounted to Spectrometer Housing

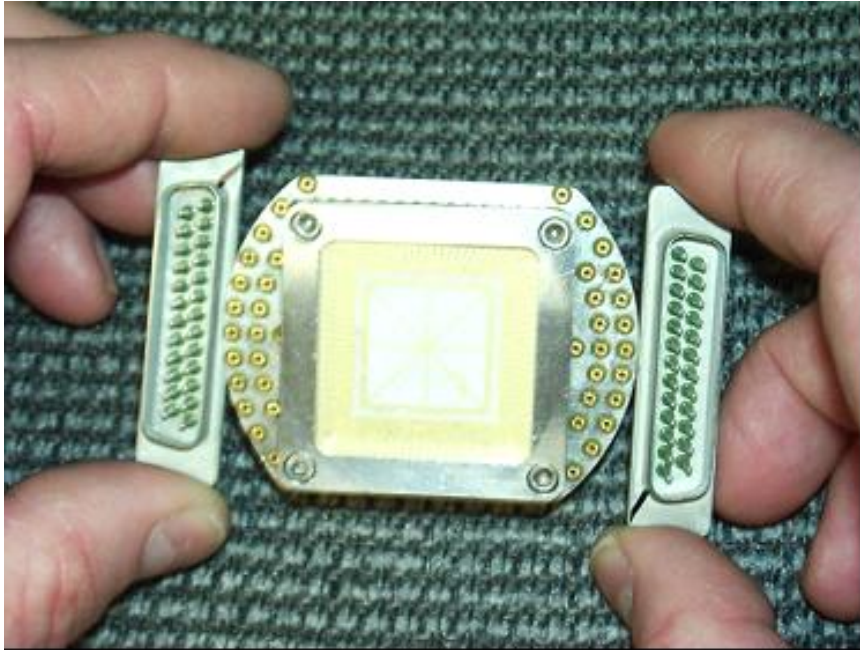

The FPA pedestal assembly from the spectrometer side shows DB25M terminations that plug into the motherboard electronics.

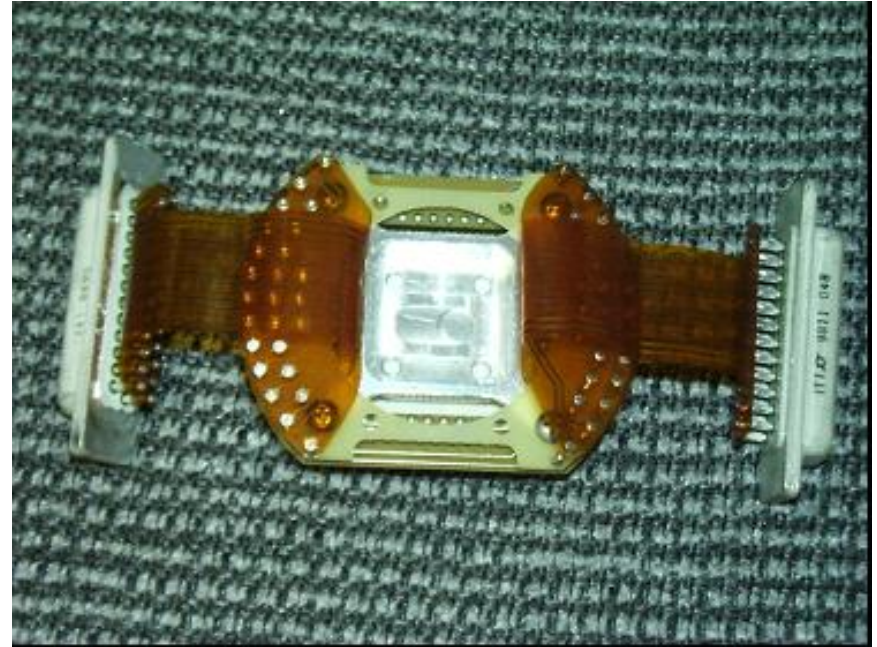

Shown from the cooler side, the pedestal assembly will use two constantan ribbon cables to provide electrical connection as well as mechanical and thermal isolation from the spectrometer housing.



Camera “Motherboard” Electronics & Spectrometer Orientation

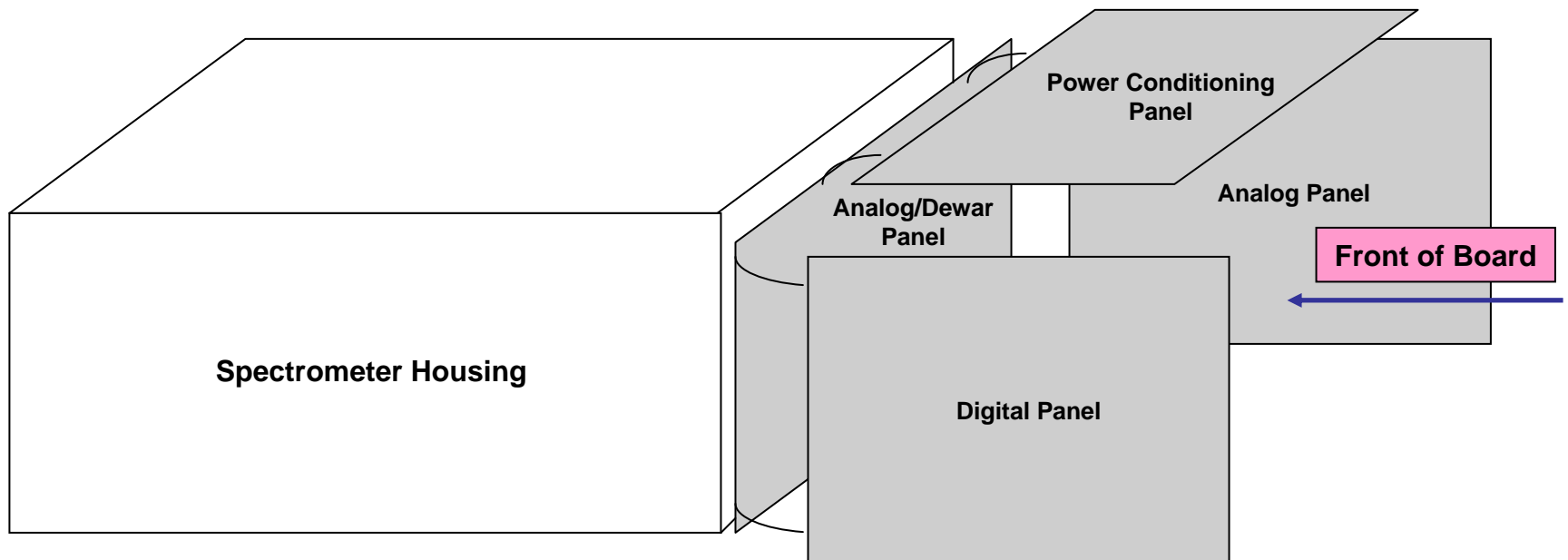

- **“Single board” camera system**
- **Provides simplified interfaces (mechanical & electrical) to cooled FPA.**
- **Interfaces to Signal Processor Board.**
- **Rigid-flex design produces compact, cubical unit.**



Rigid-Flex Placement Complete, Board In Fabrication

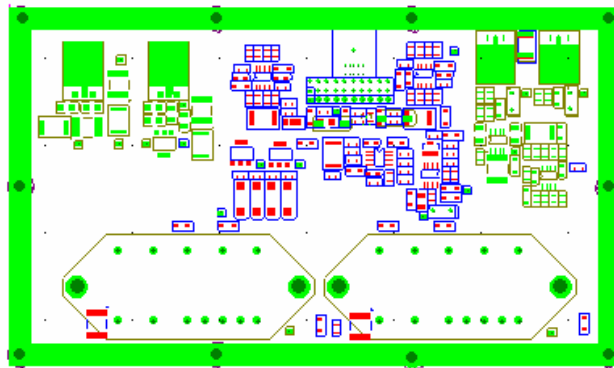

Power Conditioning Panel
Voltage regulation, power form creation.

Flex sections



Thermal plane connections along edges, at mounting holes.

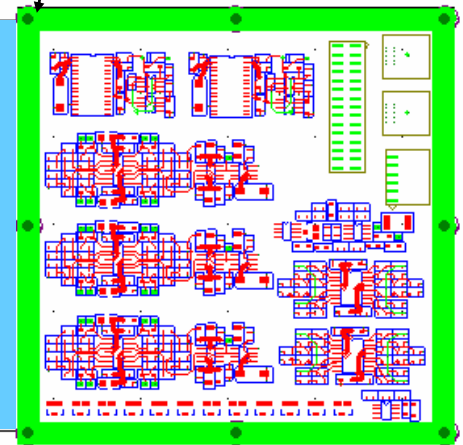
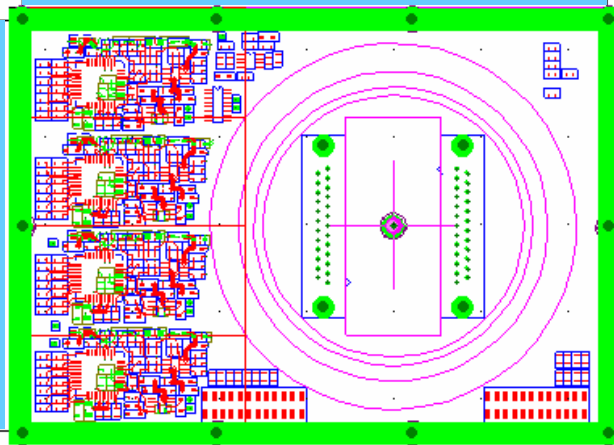
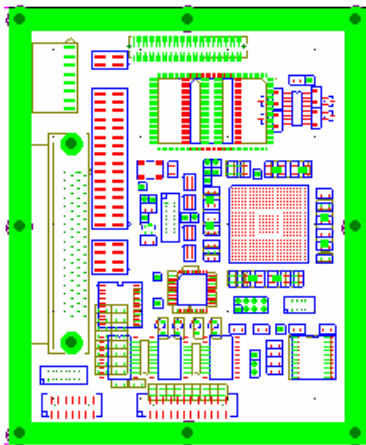

Digital Panel

Clock generation, processor board interface, video interface to GSE Equipment

Dewar and A/D Panel

Analog Panel, system monitors



Overview of Laboratory Prototype Instrument



• *Dewar (LN2 & LHe)*

- Cooling dualband FPA at a temperature near 50 K (acceptably low levels of dark current)
- Cooling of the spectrometer optics up to and including the spectrometer slit
- Temperature controlled stage for the FPA

• *Spectrometer Slit*

- At the focus of an infrared camera lens mounted external to the dewar

• *Camera Electronics* –

- A “dualband” display capability, i.e., one displaying the pair of spectral images, would be required
- Pixel gain and offset corrections
- Provision for spectral image corrections and “atmospheric correction”

• *Camera Fore-optics*

- Image over a broad (MWIR to LWIR) range of wavelengths (F/2.35, 400 mm)



Modeled, 77 Kelvin, Spectral Responsivity of Focal Plane Array

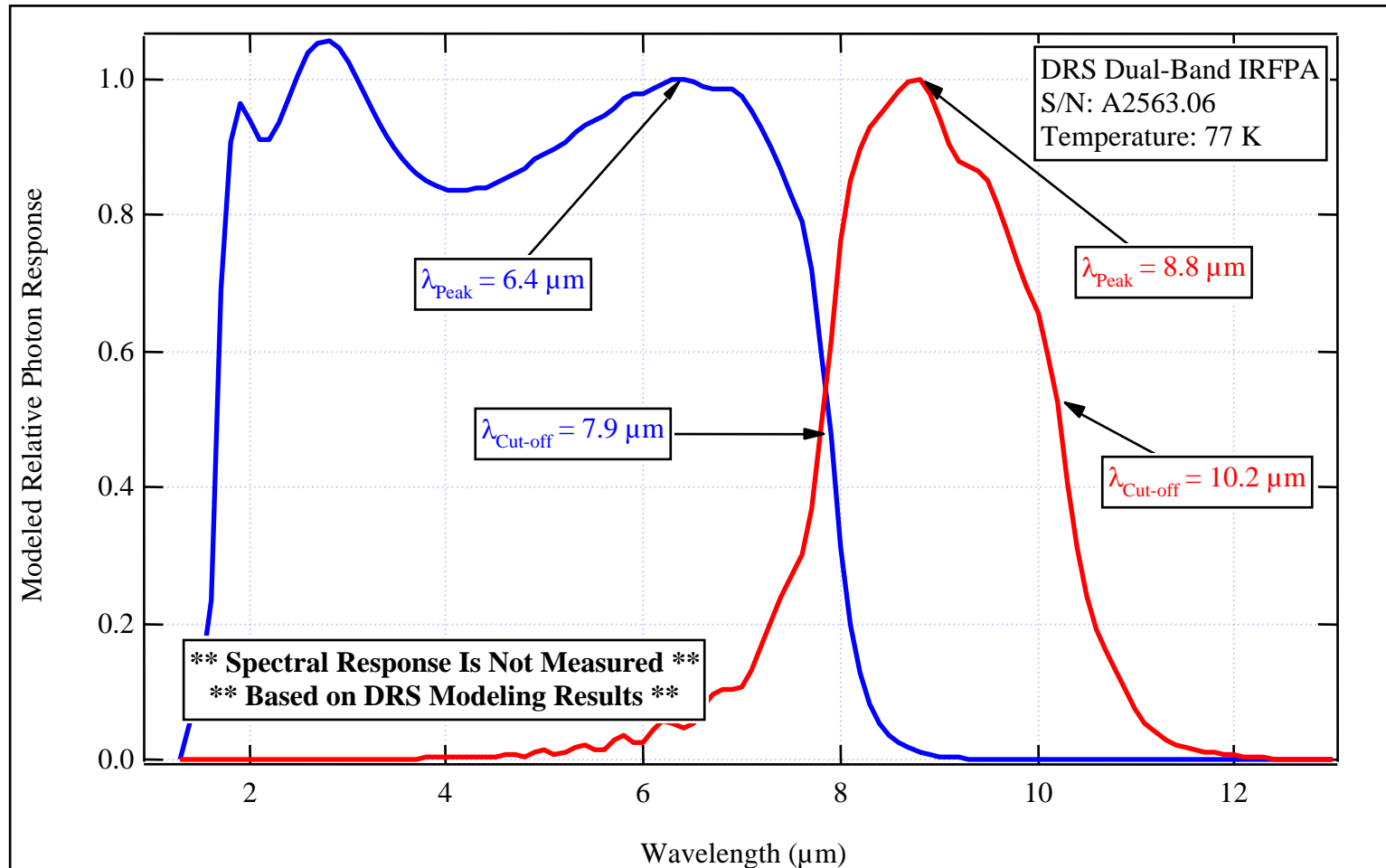



Initial data collect with Prototype Sensor– Test FPA & Fresnel Lens



- Used Fresnel lens (awaiting Janos lens)
- FPA with cut-offs near 8.5 and 10.5 μm (awaiting 6.5/12 μm)

Prototype Set-up (with Janos Lens)

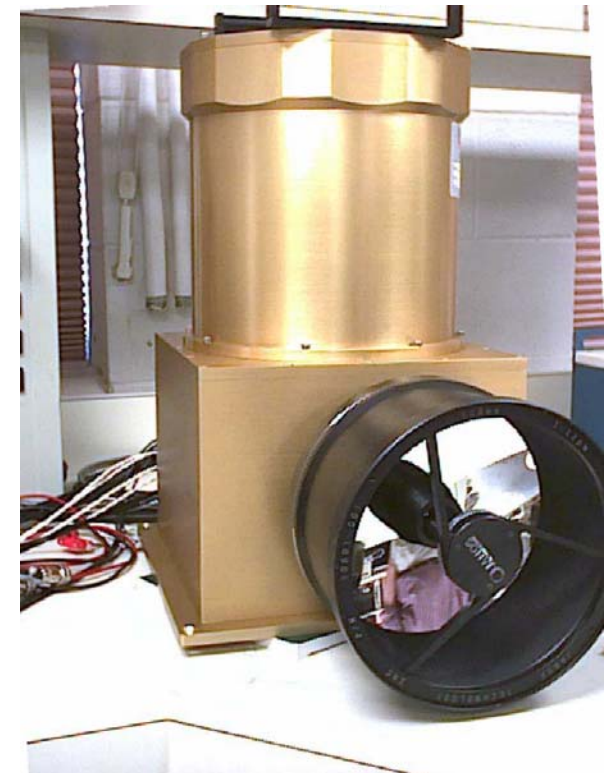

Preliminary wavelength calibration – LWIR edges near 7 and 12 microns

$$f(0) = 7.042 \quad f(1) = 11.754$$

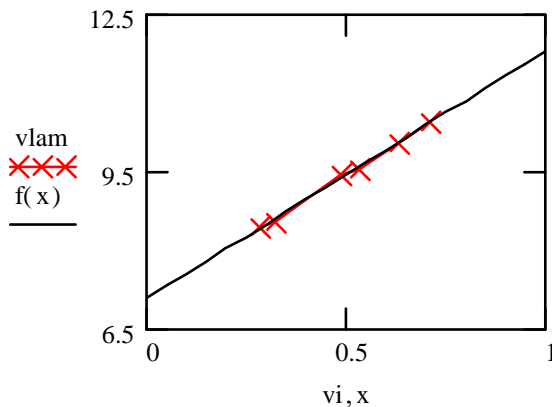

Blackbody imaged with Fresnel lens through L spectral filter

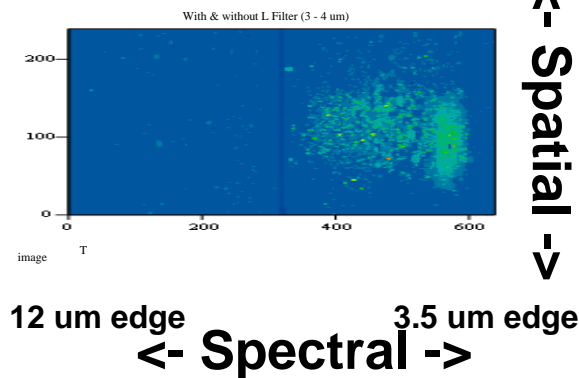



Calibration (400K & 550K) & Recovered (500K) Blackbody Spectra*

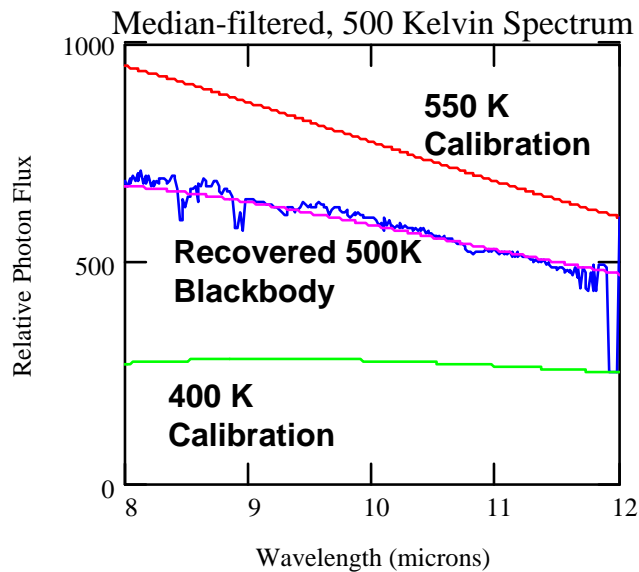

Instrumental spectral corrections include ...

- Grating efficiency
- FPA spectral response
- Fresnel lens

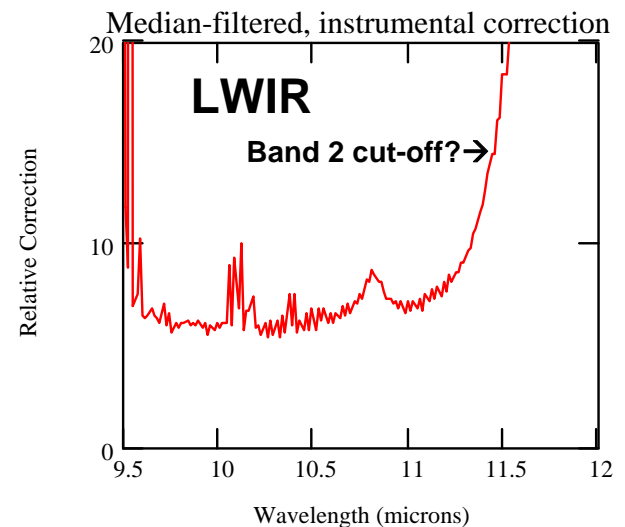
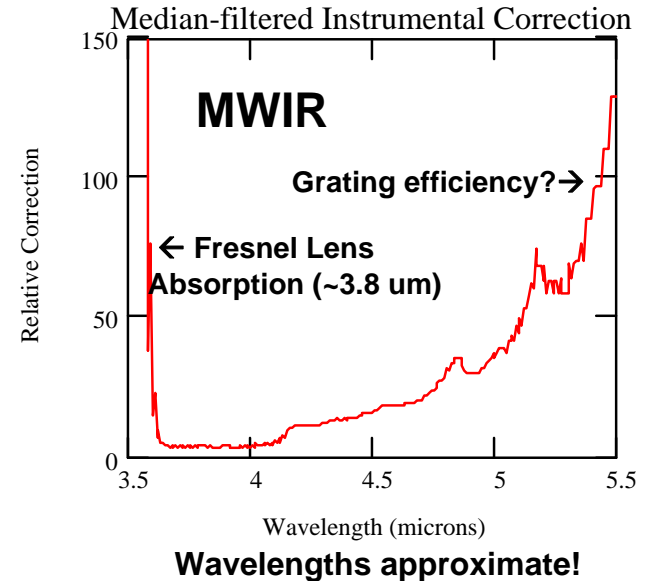

Spectrometer reproduces LWIR blackbody shape & level!

*** Non-optimized, uses Plastic Fresnel Lens for Fore-optics**



Recovered MWIR Spectrum Shows “LWIR Leak” for “Test FPA”

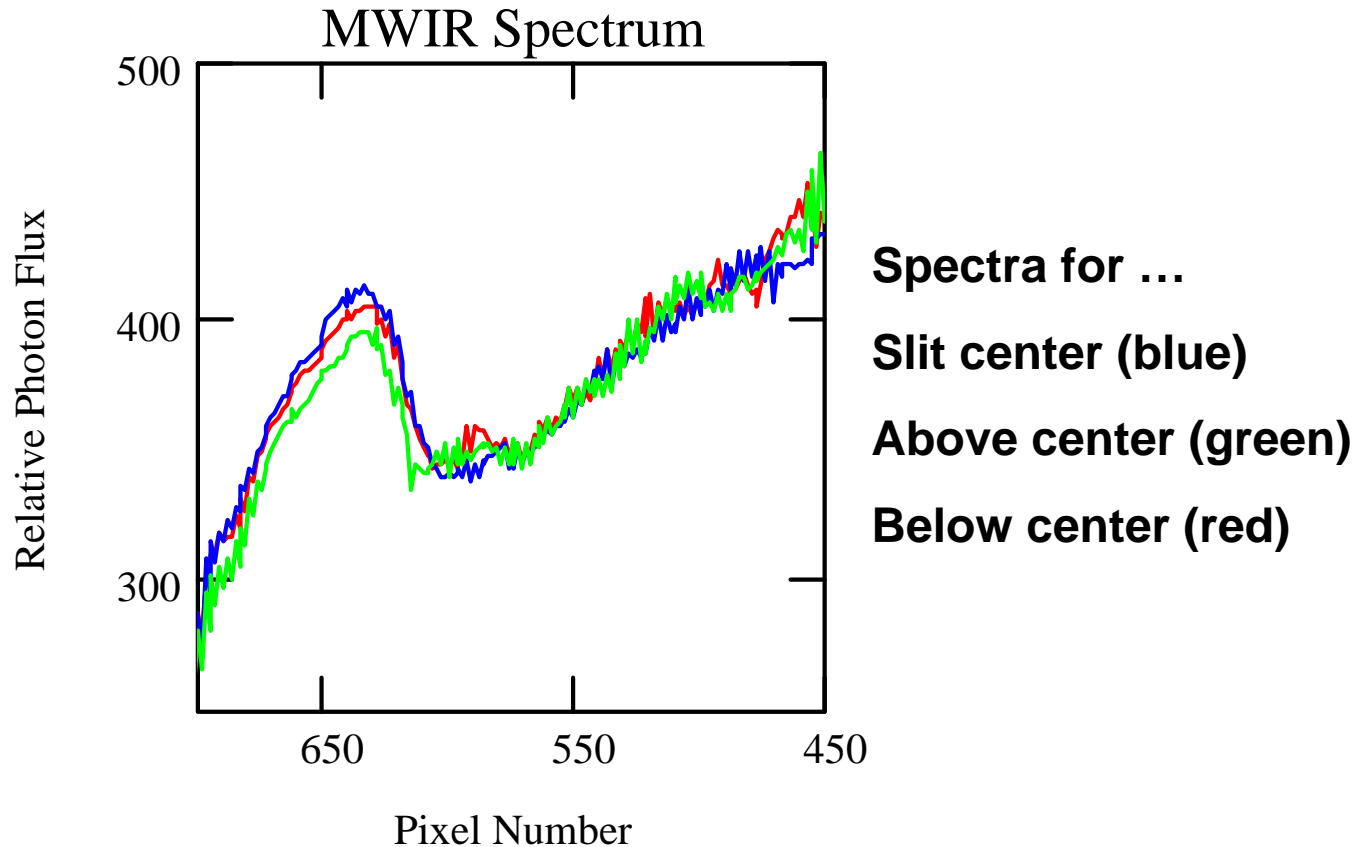

Band 1 cut-off (near 8 microns) results in Band 1 response to both grating orders, near 4 and 8 microns



Recovered MWIR Spectrum also needs Non-linear Calibration

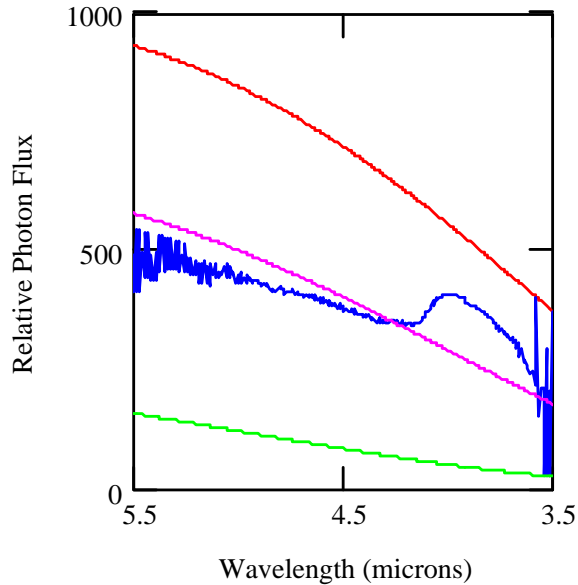

← Before

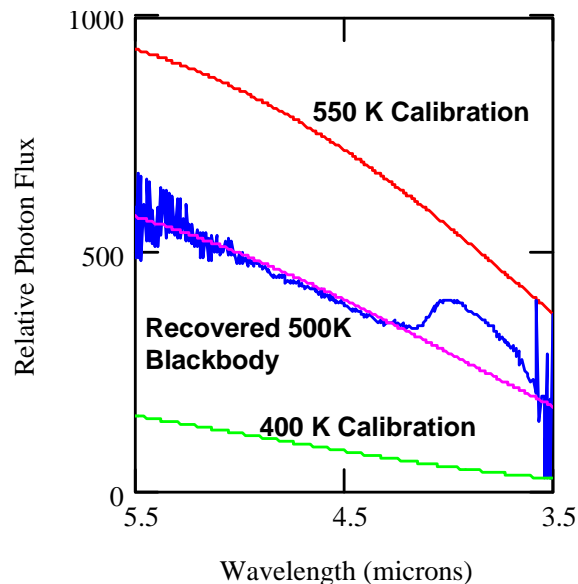

← After

Possible culprits:

Hot (550K) blackbody “excites” 3rd grating order (i.e., 2.3 to 4 μm)

Probably not spectral crosstalk (see FPA spectral response)

Not detector non-linearity; curvature of signal vs flux is positive

Not error in assumed blackbody temperatures or wavelength calibration



Distant Blackbody Source, small angular extent



*One inch diameter blackbody at a distance of
about 100 meters; corresponds to 0.25
milliradian*

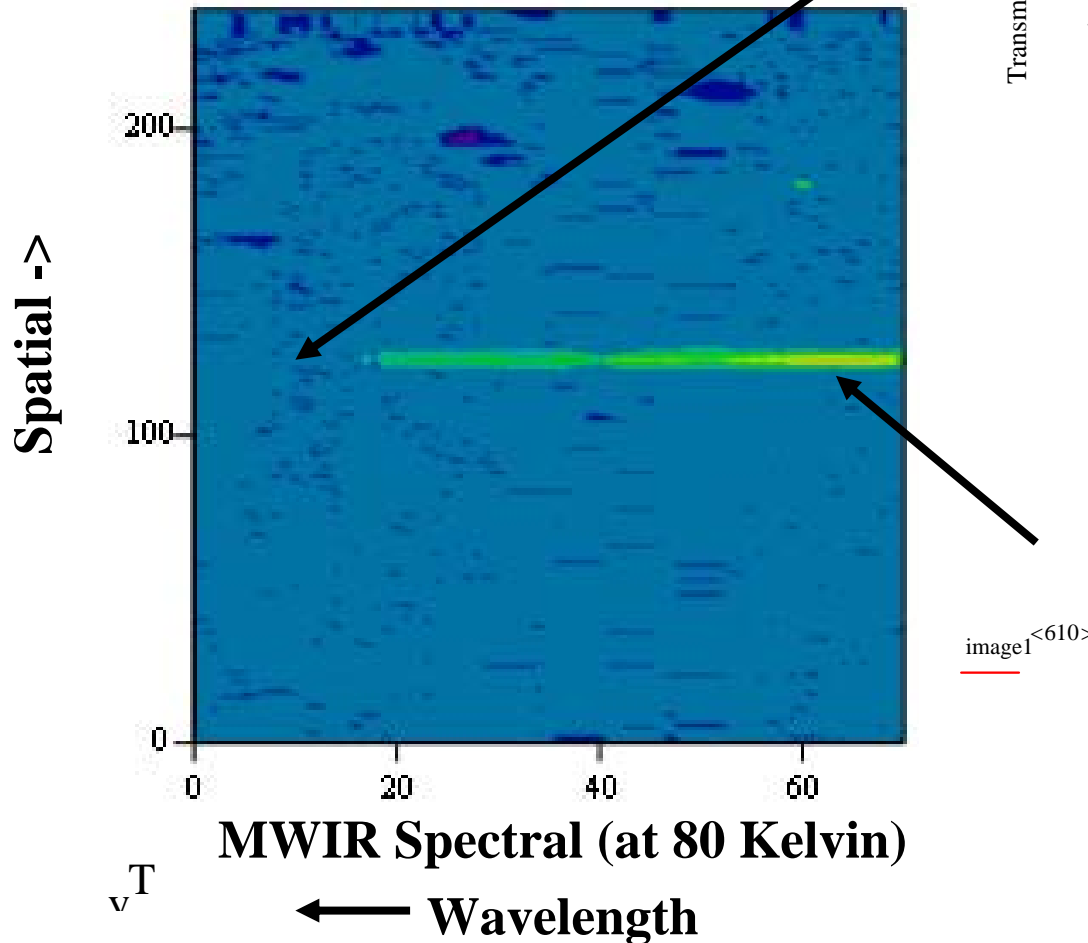

Atmospheric CO₂

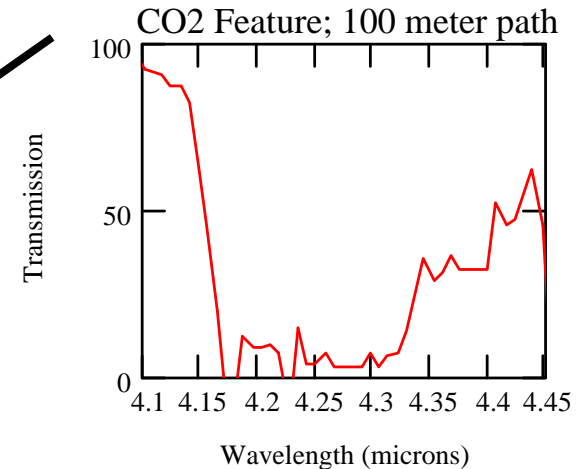

**Measured spatial
FWHM: ~4 pixels or
0.29 milliradian**

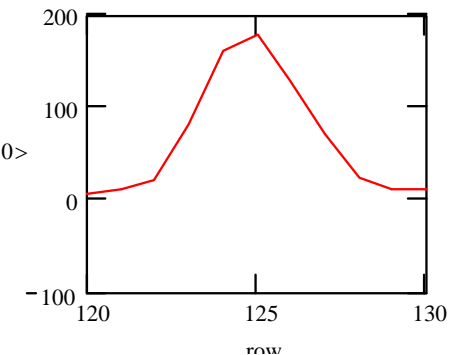



Acknowledgements



This combined work effort has been supported under US Small Business Innovative Research contracts, and is the execution of a US-government-owned patent.

We acknowledge SSG Precision Optronics (Massachusetts) & Nova Sensors (California)