

Copy 1

000314

---

Report to  
**United States Army  
Toxic and Hazardous  
Materials Agency**  
January 1988

---

**Implementation of  
Plastic Media Blasting (PMB)  
at U.S. Army Depots**

**(Task Order Number 9)**

**Final Report/Test Plan**

**A.A. Balasco  
Program Manager**

**R.S. Lindstrom — Task Leader  
R.C. Bowen  
C.C. Scholl  
Principal Investigators**

USATHAMA  
TECH INFO CTR

DO NOT REMOVE  
FROM FACILITY

COPY 1

**Distribution Unlimited**

**20071017013**

---

 **Arthur D. Little, Inc.**

Contract No. DAAK11-85-D-0008

Reference 54149

USATHAMA Reference AMXTH-TE-CR-87120

The views, opinions, and/or findings contained in this report should not be construed as an official Department of the Army position, policy, or decision, unless so designated by other documentation.

The use of trade names in this report does not constitute an official endorsement or approval of the use of such commercial products. This report may not be cited for purposes of advertisement.

REPORT DOCUMENTATION PAGE

1a. REPORT SECURITY CLASSIFICATION <b>UNCLASSIFIED</b>			1b. RESTRICTIVE MARKINGS		
2a. SECURITY CLASSIFICATION AUTHORITY			3. DISTRIBUTION / AVAILABILITY OF REPORT <b>Unlimited</b>		
2b. DECLASSIFICATION / DOWNGRADING SCHEDULE					
4. PERFORMING ORGANIZATION REPORT NUMBER(S)  Reference: 54149			5. MONITORING ORGANIZATION REPORT NUMBER(S)  AMXTH-TE-CR-87120		
6a. NAME OF PERFORMING ORGANIZATION Arthur D. Little, Inc.		6b. OFFICE SYMBOL (if applicable)	7a. NAME OF MONITORING ORGANIZATION U.S. Army Toxic and Hazardous Materials Agency		
6c. ADDRESS (City, State, and ZIP Code) Acorn Park Cambridge, Massachusetts 02140-2390			7b. ADDRESS (City, State, and ZIP Code) Attn: AMXTH-TE-D Aberdeen Proving Ground, Maryland 21010-5401		
8a. NAME OF FUNDING / SPONSORING ORGANIZATION U.S. Army Toxic & Hazardous Materials Agency		8b. OFFICE SYMBOL (if applicable) AMXTH-TE-D	9. PROCUREMENT INSTRUMENT IDENTIFICATION NUMBER Contract No. DAAK11-85-D-0008 Task Order No. 9		
8c. ADDRESS (City, State, and ZIP Code) Attn: AMXTH-TE-D Aberdeen Proving Ground, Maryland 21010-5401			10. SOURCE OF FUNDING NUMBERS		
			PROGRAM ELEMENT NO.	PROJECT NO.	TASK NO. 9
					WORK UNIT ACCESSION NO.
11. TITLE (Include Security Classification) Implementation of Plastic Media Blasting (PMB) at U.S. Army Depots					
12. PERSONAL AUTHOR(S) A.A. Balasco, R.S. Lindstrom, R.C. Bowen and C.C. Scholl					
13a. TYPE OF REPORT Final		13b. TIME COVERED FROM 7/86 TO 1/88		14. DATE OF REPORT (Year, Month, Day) 31 January 1988	15. PAGE COUNT 219
16. SUPPLEMENTARY NOTATION					
17. COSATI CODES			18. SUBJECT TERMS (Continue on reverse if necessary and identify by block number)		
FIELD	GROUP	SUB-GROUP	<ul style="list-style-type: none"> <li>• Depainting</li> <li>• Paint Waste</li> <li>• CARC Paint</li> <li>• Plastic Media Blasting</li> <li>• Abrasive Blasting</li> <li>• Chemical Stripping</li> <li>• Sand Blasting</li> </ul>		
19. ABSTRACT (Continue on reverse if necessary and identify by block number) Objectives: The objectives of Task Order Number 9, entitled "Implementation of Plastic Media Blasting," under U.S. Army Toxic and Hazardous Material Agency (USATHAMA), Contract No. DAAK11-85-D-0008, were fourfold: (1) Evaluate current depainting practices at U.S. Army depots; (2) Evaluate the state of the art in plastic media blasting (PMB); (3) Provide guidance and recommendations to the U.S. Army for implementation of PMB technology in lieu of or in addition to existing depainting operations where PMB is technically, environmentally, and economically justified; and (4) Prepare a test plan to address areas identified during the study as requiring additional data. <u>Findings and Conclusions:</u> PMB is a relatively new process; the first full-scale use of PMB began in 1985 at Hill Air Force Base. The primary application of PMB to date has been as a replacement for chemical stripping of aircraft by the U.S. Air Force, Navy, Army (Corpus Christi Army Depot), and civil aviation. In this application PMB eliminates severe U.S. Environmental Protection Agency (EPA) and Occupational Safety and Health Administration (OSHA) problems associated with chemical stripping and, in addition, can be very cost effective due to reduced					
20. DISTRIBUTION / AVAILABILITY OF ABSTRACT <input checked="" type="checkbox"/> UNCLASSIFIED/UNLIMITED <input type="checkbox"/> SAME AS RPT. <input type="checkbox"/> DTIC USERS			21. ABSTRACT SECURITY CLASSIFICATION UNCLASSIFIED		
22a. NAME OF RESPONSIBLE INDIVIDUAL Erik B. Hangeland			22b. TELEPHONE (Include Area Code) (301) 671-2054	22c. OFFICE SYMBOL AMXTH-TE-D	

labor requirements. However, substantial concern has arisen regarding possible damage to thin aluminum substrates and composites by PMB. This issue is currently under intensive study in several U.S. Air Force programs.

The cost effectiveness and hazardous waste reduction potential for PMB is much less clear in depainting operations where abrasive blasting with other media is utilized. For instance, barring extreme changes in hazardous waste regulations and disposal costs, PMB is simply not competitive with aggressive, low-cost media such as sand and alternative low silica minerals. The aggressive media are used to not only remove paint but also remove corrosion and a small amount of metal to assure the white metal surface and anchor pattern necessary to assure good adhesion when the material is repainted. Also, the aggressive media provide very high production rates which cannot be matched by plastic media even if the plastic could remove corrosion and provide a white metal surface with an anchor pattern.

Because of the low cost, the aggressive media is recycled little, if at all. As a result, the spent media has a low heavy metal concentration and is not considered a hazardous waste, so that disposal costs are low even though the volume is large.

The primary "soft" blasting media for depainting substrates that cannot withstand aggressive blasting is walnut shells. Although the shells cost \$0.11 to \$0.20/lb compared with \$1.80 to \$2.00/lb for plastic media, the plastic media is potentially competitive with walnut shells because of higher recycle rates and competitive paint removal rates. In addition, the shells generate much dust which hinders operator visibility and may reach concentrations that represent explosion hazards. As the result of the dust problem, OSHA regulations are calling for use of nut shells and other dust-generating agricultural media only in automated blast facilities. Ultimately, the economic advantage of nut shells versus plastic media may depend on whether the substantial amount of waste from the nut shell blasting must be classified as a hazardous waste.

The question of whether the spent media and dust are a hazardous waste is determined by the EP Toxicity test for leachable heavy metals. Chromium, lead, and cadmium are the metals in the paint waste that have the potential to exceed EPA limits thereby making the waste hazardous. With the increasing cost of hazardous waste disposal (in some cases up to \$300 to \$500 per 55-gallon drum), the question of whether the waste is hazardous is critically important to the economics of PMB. If low-cost media like sand or nut shells is used with low recycle rates, the heavy metal concentration is low enough that the waste is generally not hazardous by current regulations; and disposal costs are low. However, if the blast residue is high enough in heavy metals to classify the waste as hazardous, the economic advantage may lie with the plastic media which is recycled many times and, therefore, generates a lesser volume of hazardous waste for disposal. Because of these considerations, EPA regulations regarding hazardous waste and landfilling and future changes in these regulations have a very significant impact on the cost effectiveness of PMB.

Because PMB is a new technology, the plastic media itself is still in an evolutionary stage. Variable durability (recycle rate) has been reported in the available media indicating a lack of quality control in media manufacture. Since the recycle rate for the high cost plastic media is important to PMB economics, a consistent high durability media is important. A Tri-Service specification for the media is still in the development and approval stage. This specification is very important because the number of media suppliers is rapidly increasing, and a basis for judging and comparing the media quality is needed.

Operator skill and training are also very important to the efficient use of PMB and minimization of substrate damage. The process is very sight-oriented and dependent on experienced personnel. In some cases, job grades may have to be raised to retain trained, skilled operators as PMB operators.

There are additional new depainting methods under development and evaluation which utilize xenon flashlamps, lasers, CO<sub>2</sub> pellets, and various types of thermal decomposition to remove the paint. These techniques should be studied and tracked as they continue to develop in order to evaluate them and assure that the Army is utilizing the best available, current technology for each type of depainting operation.

Recommendations: 1. Undertake a test program to define the advantages and disadvantages, both technical and economic, of the use of PMB for depainting on various items of Army material. This program is needed because the primary applications of PMB to date have been on

19. Abstract for Task 9 (continued)

aircraft where it was replacing chemical stripping. Where PMB has been used as an alternative to other blasting media for paint removal, the data on PMB effectiveness is highly inconsistent. Additional data must be developed to define the cost effectiveness of PMB on the wide range of types of Army materiel that are processed at the depots.

2. Continue to study and track possible changes in EPA regulations that might effectively lower the heavy metal limits that define a hazardous waste and/or restrict waste disposal in such a way that spent media disposal costs would rise significantly.

3. Maintain contact with personnel throughout the military and the civilian sector who are working with PMB in order to remain up to date on the various developments and fully utilize all available information on PMB as it continues to evolve as a technical process.

4. Establish within the U.S. Army Depot System Command (DESCOM) a central clearing house in depainting. This office would continuously gather and update all available information on depainting methods including PMB, provide a training program for operator certification, coordinate programs for the evaluation of new depainting techniques and equipment, evaluate the applicability of different depainting methods to various types of materiel, and maintain an up-to-date database on depainting that would be a resource for the various depots and field activities.

## TABLE OF CONTENTS

	<u>Page</u>
S.0 SUMMARY	S-1
S.1 Objectives	S-1
S.2 Findings and Conclusions	S-1
S.3 Recommendations	S-3
1.0 INTRODUCTION	1-1
1.1 Background	1-1
1.1.1 Chemical Stripping	1-1
1.1.2 Abrasive Blasting	1-2
1.2 Objectives and Scope	1-5
2.0 STATE OF THE ART IN PMB	2-1
2.1 Media	2-1
2.2 Equipment and Facilities	2-3
2.3 Implementation by U.S. Air Force and Navy	2-4
2.4 Commercial Use	2-5
3.0 DEPAINTING PRACTICES AT VARIOUS U.S. ARMY DEPOTS	3-1
3.1 Anniston Army Depot	3-1
3.2 Corpus Christi Army Depot	3-2
3.3 Letterkenny Army Depot	3-4
3.4 Lexington/Bluegrass Army Depot	3-4
3.5 Red River Army Depot	3-4
3.6 Sacramento Army Depot	3-5
3.7 Tobyhanna Army Depot	3-6
3.8 Tooele Army Depot	3-7
4.0 KEY ISSUES SURROUNDING PMB	4-1
4.1 Environmental Regulations	4-1
4.2 OSHA Regulations	4-2
4.3 Substrate Damage	4-2
4.3.1 Cladding Removal	4-3
4.3.2 Fatigue Crack Masking	4-3
4.3.3 Crack Initiation	4-3
4.3.4 Fatigue Life Reduction	4-3
4.3.5 Composite Substrates	4-4

TABLE OF CONTENTS  
(continued)

	<u>Page</u>
4.4 Non-Aircraft Applications of PMB	4-4
4.5 Economics of PMB	4-5
4.5.1 Capital Costs	4-5
4.5.2 Operating Costs	4-5
4.6 Alternative Depainting Methods	4-7
4.6.1 Xenon Flashlamp	4-7
4.6.2 Laser Depainting	4-7
4.6.3 CO <sub>2</sub> Pellet Blasting	4-7
4.6.4 Molten Salt Bath	4-7
4.6.5 High Temperature Air Bake	4-8
5.0 RECOMMENDATIONS FOR IMPLEMENTING PMB	5-1
5.1 Test Plan	5-1
5.2 Depainting Clearing House	5-1
6.0 PRELIMINARY TEST PLAN FOR PMB EVALUATION	6-1
6.1 Overall LEAD Test Program	6-1
6.1.1 Objective	6-1
6.1.2 Approach	6-1
6.1.3 Test Procedure	6-2
6.2 Test Series 1	6-17
6.2.1 Objective	6-17
6.2.2 Test Procedure	6-17
6.3 Test Series 2	6-17
6.3.1 Objective	6-17
6.3.2 Media for Testing	6-18
6.3.3 Test Procedure	6-20
6.4 Test Series 3	6-20
6.4.1 Objective	6-20
6.4.2 Test Procedure	6-20
6.5 Test Series 4	6-20
6.5.1 Objective	6-20
6.5.2 Test Procedure	6-20
6.6 Assistance Needed from Depots	6-20
6.7 Automated Equipment for Small Parts Blasting	6-21
6.8 Updating of PMB Developments	6-22
6.9 Reporting	6-23
6.10 Schedule	6-23

TABLE OF CONTENTS  
(continued)

	<u>Page</u>
7.0 REFERENCES	7-1
APPENDIX A Depot Telephone/Site Visit Summaries	A-1
APPENDIX B Plastic Media Manufacturers Literature	B-1
APPENDIX C Original Draft Specification for Plastic Media	C-1
APPENDIX D PMB Reports from LEAD, AAD, and RRAD	D-1
APPENDIX E Paint Thickness Gauge Measurement Procedures	E-1

LIST OF TABLES

		<u>Page</u>
Table 1-1	Type and Cost of Typical Blast Media	1-3
Table 1-2	Summary Listing of U.S. Army/Air Force Installations Visited	1-7
Table 2-1	Comparison of Chemical/Physical Properties of Plastic Media and Competitive Other Media	2-2
Table 2-2	U.S. Air Force Follow-on Testing Programs	2-6
Table 4-1	PMB Facility Capital Costs	4-6
Table 6-1	Pilot PMB Test Matrix	6-3
Table 6-2	Plastic Media Blasting Test Program/Small Parts Testing Information 8V Engine Parts	6-5
Table 6-3	Smoke Generator Parts	6-7
Table 6-4	8V Engine Parts	6-9
Table 6-5	Media Size Log	6-13
Table 6-6	Parts Log	6-15
Table 6-7	Media Log	6-16
Table 6-8	Plastic Blast Media to be Tested	6-19
Table 6-9	Milestone Schedule	6-24

## S.0 SUMMARY

### S.1 Objectives

The objectives of Task Order Number 9, entitled "Implementation of Plastic Media Blasting," under U.S. Army Toxic and Hazardous Material Agency (USATHAMA), Contract No. DAAK11-85-D-0008, were fourfold:

- (1) Evaluate current depainting practices at U.S. Army depots;
- (2) Evaluate the state of the art in plastic media blasting (PMB);
- (3) Provide guidance and recommendations to the U.S. Army for implementation of PMB technology in lieu of or in addition to existing depainting operations where PMB is technically, environmentally, and economically justified; and
- (4) Prepare a test plan to address areas identified during the study as requiring additional data.

### S.2 Findings and Conclusions

PMB is a relatively new process; the first full-scale use of PMB began in 1985 at Hill Air Force Base. The primary application of PMB to date has been as a replacement for chemical stripping of aircraft by the U.S. Air Force, Navy, Army (Corpus Christi Army Depot), and civil aviation. In this application PMB eliminates severe environmental pollution and occupational safety and health problems associated with chemical stripping and, in addition, can be very cost effective due to reduced labor requirements. However, substantial concern has arisen regarding possible damage to thin aluminum substrates and composites by PMB. This issue is currently under intensive study in several U.S. Air Force programs.

The cost effectiveness and hazardous waste reduction potential for PMB is much less clear in depainting operations where abrasive blasting with other media is utilized. For instance, barring extreme changes in hazardous waste regulations and disposal costs, PMB is simply not competitive with aggressive, low-cost media such as sand and alternative low silica minerals. The aggressive media are used to not only remove paint but also remove corrosion and a small amount of metal to assure the white metal surface and anchor pattern necessary to assure good adhesion when the material is repainted. Also, the aggressive media provide very high production rates which cannot be matched by plastic media even if the plastic could remove corrosion and provide a white metal surface with an anchor pattern.

Because of the low cost, the aggressive media is recycled little, if at all. As a result, the spent media has a low heavy metal concentration and is not considered a hazardous waste, so that disposal costs are low even though the volume is large.

The primary "soft" blasting media for depainting substrates that cannot withstand aggressive blasting is walnut shells. Although the shells cost \$0.11 to \$0.20/lb compared with \$1.80 to \$2.00/lb for plastic media, the plastic media is potentially competitive with walnut shells because of higher recycle rates and competitive paint removal rates. In addition, the shells generate much dust which hinders operator visibility and may reach concentrations that represent explosion hazards. As the result of the dust problem, OSHA regulations<sup>(1)</sup> are calling for use of nut shells and other dust-generating agricultural media only in automated blast facilities. Ultimately, the economic advantage of nut shells versus plastic media may depend on whether the substantial amount of waste from the nut shell blasting must be classified as a hazardous waste.

The question of whether the spent media and dust are a hazardous waste is determined by the EP Toxicity test for leachable heavy metals. Chromium, lead, and cadmium are the metals in the paint waste that have the potential to exceed EPA limits thereby making the waste hazardous. With the increasing cost of hazardous waste disposal (in some cases up to \$300 to \$500 per 55-gallon drum), the question of whether the waste is hazardous is critically important to the economics of PMB. If low-cost media like sand or nut shells is used with low recycle rates, the heavy metal concentration is low enough that the waste is generally not hazardous by current regulations; and disposal costs are low. However, if the blast residue is high enough in heavy metals to classify the waste as hazardous, the economic advantage may lie with the plastic media which is recycled many times and, therefore, generates a lesser volume of hazardous waste for disposal. Because of these considerations, EPA regulations regarding hazardous waste and landfilling and future changes in these regulations have a very significant impact on the cost effectiveness of PMB.

Another significant and potential long-term advantage for PMB from an environmental perspective is the fact that because the plastic is organic, the waste, including removed paint as well as spent media, may be incinerated or pyrolyzed under properly controlled conditions. These processes may reduce the waste to only the inorganic content which constitutes a very small percentage of the total waste volume. Such a process may even concentrate the heavy metals to the point where they become economically recoverable. The possibility of incineration would apply also to other organic media such as nut shells.

Another aspect of environmental concern that the Army might consider is the fact that even though sandblast wastes may pass the current EPA requirements so that they can be landfilled as non-hazardous waste, large quantities of such waste in a given location may still present a long-term environmental problem. Even though the concentrations in the sand are low, the heavy metals might still leach and contaminate groundwater supplies. By elimination of this possibility, the Army could take a leadership role in the environmental field. However, the cost of such action could be significant.

Because PMB is a new technology, the plastic media itself is still in an evolutionary stage. Variable durability (recycle rate) has been reported in the available media indicating a lack of quality control in media

manufacture. Since the recycle rate for the high cost plastic media is important to PMB economics, a consistent high durability media is important. A Tri-Service specification for the media is still in the development and approval stage. This specification is very important because the number of media suppliers is rapidly increasing, and a basis for judging and comparing the media quality is needed.

Operator skill and training are also very important to the efficient use of PMB and minimization of substrate damage. The process is very sight-oriented and dependent on experienced personnel. In some cases, job grades may have to be raised to retain trained skilled operators as PMB operators.

There are additional new depainting methods under development and evaluation which utilize xenon flashlamps, lasers, CO<sub>2</sub> pellets, and various types of thermal decomposition to remove the paint. These techniques should be studied and tracked as they continue to develop in order to evaluate them and assure that the Army is utilizing the best available, current technology for each type of depainting operation.

### S.3 Recommendations

1. Undertake a test program to define the advantages and disadvantages, both technical and economic, of the use of PMB for depainting on various items of Army materiel. This program is needed because the primary applications of PMB to date have been on aircraft where it was replacing chemical stripping. Where PMB has been used as an alternative to other blasting media for paint removal, the data on PMB effectiveness is highly inconsistent. Additional data must be developed to define the cost effectiveness of PMB on the wide range of types of Army materiel that are processed at the depots.
2. Continue to study and track possible changes in EPA regulations that might effectively lower the heavy metal limits that define a hazardous waste and/or restrict waste disposal in such a way that spent media disposal costs would rise significantly.
3. Maintain contact with personnel throughout the military and the civilian sector who are working with PMB in order to remain up to date on the various developments and fully utilize all available information on PMB as it continues to evolve as a technical process.
4. Establish within the U.S. Army Depot System Command (DESCOM) a central clearing house in depainting. This office would continuously gather and update all available information on depainting methods including PMB, provide a training program for operator certification, coordinate programs for the evaluation of new depainting techniques and equipment, evaluate the applicability of different depainting methods to various types of materiel, and maintain an up-to-date database on depainting that would be a resource for the various depots and field activities.

## 1.0 INTRODUCTION

### 1.1 Background

There are three primary techniques used for paint removal in industry in general and in U.S. Army depot systems in particular. These are chemical stripping, abrasive blasting, and hand sanding. Hand sanding is highly labor intensive and, therefore, costly and is used only where one of the other two methods cannot be used for practical reasons.

#### 1.1.1 Chemical Stripping

Chemical stripping is used primarily for paint removal from substrates that would be damaged by abrasive blasting. These are primarily softer substrates such as aluminum, copper, wood, and composites. The strippers contain solvents (e.g., methylene chloride) and chemicals (e.g., phenols) that will attack, swell, and soften a wide variety of types of paint films.

In the chemical stripping of large items, the stripper is sprayed or brushed onto the surface from which paint is to be removed. The stripper for spray or brush applications normally contains a thickener (e.g., colloidal silica) so that a heavy film of stripper will remain in place even on vertical or inverted surfaces allowing the chemicals to penetrate the paint film. After sufficient time has been allowed for the paint to soften, the stripper and paint sludge are removed with a water blast and/or water flooding accompanied by mechanical scraping with a brush or squeegee. In the past, the paint stripper residue and sludge were simply flushed into the facility's wastewater treatment system. Now, however, they sometimes go into special settling and holding tanks because of the problems they create in the wastewater treatment plant.

For smaller parts, chemical stripping is done by immersion of individual parts or baskets of parts in a dip tank of stripper, usually with a water layer on top to reduce evaporation of volatile stripper components such as methylene chloride. After the parts have soaked in the stripper long enough to soften the paint, the parts are water-rinsed and frequently blasted with water or water and air to remove softened but clinging paint. The paint sludge and contaminated water from the rinse represents a hazardous waste and presents disposal problems. In addition, the paint sludge that accumulates in the dip tanks must be removed periodically, and occasionally the spent stripper must be removed and disposed of as hazardous waste.

Aside from these hazardous waste disposal problems, the dip tank stripping is a relatively efficient depainting process because no labor is involved while the parts are in the dip tank, and the rinsing and water blasting are fairly quick. However, with some paints, and particularly the new Chemical Agent Resistant Coating (CARC) paint systems, blasting with soft media such as nut shells, plastic or even glass beads may be necessary after chemical stripper exposure to fully remove the paint.

Until about 8 to 10 years ago, most of the heavy-duty paint strippers contained potent solvents such as methylene chloride and/or other

chlorinated solvents and various phenols or cresols which would also attack and soften the paint film. Because of adverse effects of the phenols and cresols on the operation of the wastewater treatment plants and in the environment in general, the EPA adopted regulations to discourage their use. At that time, most paint strippers were converted to a methylene chloride/formic acid formulation. These strippers were somewhat less efficient but still worked reasonably well.

Over the last five years, the methylene chloride/acid systems have also come under fire from the EPA because of their adverse effect on wastewater treatment systems and from OSHA because methylene chloride has been classified as a suspect carcinogen<sup>(2)</sup>. The regulatory pressure to eliminate chemical paint stripping has a significant impact on U.S. Army depots that were employing such paint stripping for depainting and particularly at Corpus Christi Army Depot (CCAD) which deals almost exclusively with refurbishing (including depainting) of helicopters. The impact of this pressure to eliminate chemical paint stripping was also severely felt by both U.S. Air Force and Naval Air facilities.

#### 1.1.2 Abrasive Blasting

The other primary method of depainting is abrasive blasting. Historically, sand blasting was the original high speed depainting method. In abrasive blasting, the abrasive media is entrained in high velocity air and directed through a nozzle against the surface to be depainted. The air pressures and flow velocities, the amount of abrasive in the air-stream, and the distance and angle of the blast nozzle from the surface being depainted are all important parameters in abrasive blast depainting.

Over the years, a large number of different abrasive media have been developed to meet a wide range of needs for paint removal and parts cleaning. A number of these media together with their current approximate cost are listed in Table 1-1.

As was previously noted, readily available local sand was probably the first abrasive blasting media used. The sand is screened to provide a limited size range of particles, and the cost is still in the \$0.01 to \$0.02 per pound range. Frequently, however, local sand will be somewhat rounded and will fracture too easily to provide high efficiency paint removal. Therefore, a high silica sand is sometimes utilized. This sand tends to be harder with sharper cutting edges. Although it is somewhat more costly to purchase (\$0.02 to \$0.025 per pound), it frequently results in a lower operating cost due to the fact it produces a faster paint removal rate which reduces labor costs. Because of its low cost, even silica sand is not recycled at all, or only one or two times at most.

In recent years, however, there has been increasing pressure from OSHA to totally discontinue sand blasting because of problems of inhalation of the dust and resulting silicosis. Even though the sandblast operators wear protective suits and have a separate air supply, there are still problems of inhalation of the fine silica dust that is generated by the sand blasting operations during cleanup of blasted parts and other times when the fine dust can become airborne.

TABLE 1-1

TYPE AND COST OF TYPICAL BLAST MEDIA

<u>Blasting Media</u>	<u>Cost (Cents/Pound)</u>
Sand	1.5 - 2.0
Silica Sand	2.0 - 2.5
Copper Slag	2.0 - 2.5
Peridot and Staurolite	3.0 - 5.0
Walnut Shells	11 - 20
Steel Grit/Shot	20 - 30
Glass Beads	30 - 35
Aluminum Oxide	35
Garnet	40
Plastic Beads	180 - 230

Source: Arthur D. Little, Inc., based on data from  
U.S. Army Depot Procurement and Manufacturers.

Another low cost abrasive media that circumvents the silicosis problem is copper slag which is ground and sized for use as a blasting abrasive. However, the slag generates much undesirable dust in use and has limited use on substrates such as aluminum where it can leave debris in the soft metal that can induce corrosion. In addition, residual copper slag on the metal surfaces may poison corrosion resistant chemical pretreatment baths if it is not fully removed prior to such treatment.

Because of the concern about silicosis and the problems with copper slag abrasive, some new mineral based abrasives are being strongly promoted. These include abrasives based on peridot and staurolite. These are naturally occurring minerals that are ground and screened to the proper size for use as abrasive blasting media. At \$0.03 to \$0.05 a pound, these alternative minerals are nearly 2-1/2 times more expensive than local sand, but it is claimed that they are more durable and can be recycled several times so that they are cost-competitive with sand in terms of overall cost.

Steel grit and shot are commonly used for abrasive blasting. The shot is used most commonly where a peening of the surface is desired to remove mill scale and heavy corrosion. Steel grit is somewhat sharper and is used more commonly for removing paint and varnish deposits on engine components, etc. The steel grit is about 10 times the cost of sand per pound, but it is extremely durable and can be recycled as many as 50 to 100 times so that it is probably the most efficient of all media in terms of media cost per unit of surface cleaned or depainted.

Aluminum oxide and garnet are synthetic and natural abrasives respectively that have higher durability and greater cutting power than any of the low cost abrasives. Because of these properties, they sometimes prove to be most cost effective on the basis of the combination of durability and faster cutting rate which reduces labor cost.

Glass beads do not have the aggressive cutting power of some of the other abrasives. For this reason, they are used on metal parts that have machined surfaces that must not be excessively disrupted. For example, they are frequently used on engine parts for cleanup.

Walnut shells and other agricultural media (corn cobs, etc.) have been widely promoted and used as soft abrasives in the blasting process. They are relatively low in cost but have limited durability. They are soft enough to be used on aluminum sheet and machined metal surfaces with minimum damage to the surface. Because they are natural products, however, their properties can vary from season to season. Also they are subject to changes in properties with changing ambient humidity and to decay from fungus attack if they are not kept totally dry. Consequently, the ability to consistently maintain a high product quality for this media is difficult, at best. In addition, during blasting operations the agricultural media generate much fine dust which not only hinders visibility of the blast nozzle operator but also creates a potential explosion hazard. For this reason, OSHA regulations require that agricultural media be used only in fully automated blasting facilities<sup>(1)</sup>. However, where adequate ventilation is used for dust removal, exemptions to this rule are allowed.

The most recent entry into the abrasive media blasting field is plastic media. The media was originally developed as an outlet for waste thermoset resin from button-making operations. Because thermoset resins cannot be reprocessed like thermoplastics, alternative uses for the waste have been investigated for some time. The concept of grinding the waste material, screening it, and then using it for abrasive blasting media has proven to be highly successful. Because it is a synthetic material, the properties can theoretically be controlled to a much greater extent than those of the natural organic media to provide improved durability, controlled hardness, and reduced dust generation. As a result of these desirable characteristics, the use of plastic media has been growing very rapidly as an alternative to chemical depainting of paint, particularly from soft (aluminum and composite) surfaces. Plastic media blasting replacement of chemical depainting has shown improved production rates, lower costs for depainting military materiel during overhaul and reconditioning, and significant reduction in hazardous waste generation compared with chemical depainting.

## 1.2 Objectives and Scope

The objectives of this program were fourfold:

- (1) Evaluate current depainting practices at U.S. Army depots;
- (2) Evaluate the state of the art in PMB;
- (3) Provide guidance and recommendations to the U.S. Army for implementation of PMB technology in lieu of or in addition to existing facility operations where it is technically, environmentally, and economically justified; and
- (4) Prepare a test plan to address areas identified during the study as requiring additional data.

The Scope of Work included an initial literature search for existing articles and reports on PMB. These are listed in Section 7.0. This search was followed up with a telephone survey of the U.S. Army depots, U.S. Navy and Air Force installations involved in depainting operations, commercial users of PMB and PMB equipment and service suppliers. The telephone survey covered, to the extent possible, the subjects listed below, but in many cases the desired information was either not readily available or not available at all:

- type and extent of depainting operations presently in use at depot/facilities of interest,
- types of military materiel depainted, including types of paints,
- depainting schedule (e.g., type and quantity of items processed per month, etc.),
- performance of present depainting operations,
- present degree of involvement, if any, with PMB,

- current depainting operations which are potential candidates for employing PMB,
- cost (capital and operating) for current depainting operations,
- waste generation from current depainting operations,
- materiel consumption for current depainting operations,
- energy consumption for current depainting operations, and
- labor (direct and indirect) required for current depainting operations.

The telephone survey was followed up with selected site visits to eight U.S. Army depots and three U.S. Air Force bases (Table 1-2). In these visits more detailed information was obtained as a follow-up to the telephone survey focussing on such subjects as:

- present depainting operations,
- limitations of present depainting operations,
- capital investment and operating costs of current operations,
- waste generation from current depainting operations,
- facility layout, and
- potential environmental, health and economic improvements to be realized from use of PMB technology.

The combined information from the telephone survey and depot visits is summarized in Appendix A for each depot.

The next step in the Scope of Work was to develop guidelines for those situations in which PMB might be used in at the depots. However, as the visits progressed, it became clear that PMB was a highly controversial subject among depot personnel, and there was insufficient data to develop appropriate guidelines for PMB use.

The original Scope of Work has, therefore, been modified to include the development of a Test Plan for additional testing which will provide data to develop the desired guidelines for PMB use.

TABLE 1-2

SUMMARY LISTING OF U.S. ARMY/AIR FORCE INSTALLATIONS VISITED

<u>U.S. Army Depots</u>	<u>Location</u>
Anniston Army Depot	Anniston, AL
Corpus Christi Army Depot	Corpus Christi, TX
Letterkenny Army Depot	Chambersburg, PA
Lexington/Bluegrass Army Depot	Lexington, KY
Red River Army Depot	Texarkana, TX
Sacramento Army Depot	Sacramento, CA
Tobyhanna Army Depot	Tobyhanna, PA
Tooele Army Depot	Tooele, UT
 <u>U.S. Air Force Bases</u>	
Hill Air Force Base	Ogden, UT
McClellan Air Force Base	Sacramento, CA
Wright-Patterson Air Force Base	Dayton, OH

Source: Arthur D. Little, Inc.

## 2.0 STATE OF THE ART IN PMB

### 2.1 Media

The original developer of plastic media for blasting was U.S. Technology Corporation, a subsidiary of U.S. Plastic and Chemical Corporation (Putnam, CT). They supply media in three grades--Polyextra®, Polyplus®, and Type III®, which are based on thermoset polyester resin, urea formaldehyde resin, and melamine formaldehyde resin respectively. Currently, these media are by far the most widely used in both the commercial and military sectors and provide the basis for comparison in the PMB industry.

With the recognition of the potential growth in PMB, a number of other suppliers have entered the field. The available chemical and physical property data on the plastic media provided by U.S. Technology Corp. and four additional suppliers are shown relative to walnut shells and glass beads in Table 2-1. The information in Table 2-1 was obtained in telephone conversations with the manufacturers and from their literature. Copies of the literature are included in Appendix B. The aggressive blast media such as silica sand, peridot, staurolite, and aluminum oxide are, of course, much harder than the media shown in Table 2-1.

One of the additional suppliers is the Du Pont Company (Wilmington, DE). They supply two grades as indicated in Table 2-1. Type C is a thermo-setting acrylic modified with a mineral filler for increased hardness and aggressiveness in blasting. It is more friable and breaks down quicker than the Type L material, which is a high molecular weight thermoplastic acrylic. Du Pont claims that Type L can be utilized for blasting a variety of composites without damage to the substrate and with high recycle rates. In addition, if the spent Type L media contains toxic elements such as heavy metals from the stripped paint, Du Pont personnel claim that it can be heated and molded into bricks or pellets with the thermoplastic acrylic resin acting as a binder. This process encapsulates the toxic constituents so that the spent media can pass the EP Toxicity test and can be landfilled as a non-hazardous waste.

Select-Tech, Inc. (Newburgh, NY), is essentially a captive supplier to Aerolyte Systems, Division of Clemco Industries, who supply blasting equipment. They supply media grades that are nominally equivalent to those of U.S. Technology Corp. Turco Products Inc. (Westminster, CA), a subsidiary of Pennwalt, is another supplier of blasting equipment that is now supplying a single grade of plastic media, which has specifications very similar to those of DuPont Type L media.

One other supplier, MPC Industries (Knoxville, TN) is a small company which is a new entry in the plastic media field. They supply three grades which have specifications similar to the three grades provided by U.S. Technology.

The entire field of suppliers of media as well as users is awaiting the issuance of the specification for plastic media which is being prepared on behalf of the U.S. Army, Navy, and Air Force by the Naval Air Development Center (NADC) in Warminster, PA. A draft specification (see

TABLE 2-1

COMPARISON OF CHEMICAL/PHYSICAL PROPERTIES OF PLASTIC MEDIA AND COMPETITIVE OTHER MEDIA

SUPPLIER: GRADE:	Generic Walnut Shells	Generic Glass Beads	U.S. Technology Polyextra Type III	Du Pont C	Turco Turcoblax	Aerolyte (Select-Tech)		MPC Industries				
						3.0	3.5	4.0	Type I	Type II	Type M	
Density (gm/cc)	1.3	2.5	1.15	1.5	1.2	1.19	1.05	1.3	1.45	1.2	1.5	1.5
Hardness (Moh)	3	5.5	3-	3.5	4	>4.0	3.0	3.5	4.0	3.0	3.5	4.0
Impact Strength (Scale 1 to 10)	4	2	4+	6	7+	-	-	-	-	-	-	-
Moisture Content (variable)	10%	0%	<0.1%	<0.1%	<0.1%	<0.3%	<0.1%	<0.1%	-	<0.05%	<0.05%	<0.05%
Water Absorption (24 hrs, 25°C)	100%	0%	0.13%	0.5%	0.25%	-	-	-	-	-	-	-
Explosibility Index	10	0	5	0.2	<0.2	-	-	-	-	-	-	-
Min. Explosive Concentration (oz/ft <sup>3</sup> )	0.040	N/A	0.045	0.085	0.09	-	-	-	-	-	-	-
Ignition Temp (°C)				390	390	390	270	-	-	435	530	535
Chemical Nature	degrad- able	inert	inert	inert	inert	inert	inert	inert	inert	inert	inert	inert

Notes: Hardness (Moh Scale): Talc = 1 Diamond = 10  
 Impact Strength: Relative scale of comparison with 10 being strongest and 1 the most friable.  
 N/A: Not applicable

Source: Arthur D. Little, Inc.

Appendix C) for comment was issued in January 1986. We understand that there was considerable comment and that some of the provisions of that first draft specification were controversial. A redraft (see Appendix C) was, therefore, issued for comment in June of 1987. We are advised that plans now call for finalization of the specification by the end of 1988.

A sound specification is clearly needed because problems with the plastic media from the current sources have been cited by various users. A primary complaint is poor durability of the media. Even strong advocates of PMB have indicated that some batches of media received from various suppliers including the industry leader, U.S. Technology Corp., have shown much lower durability than they had expected. Poor durability is reflected in high depainting costs because of the high cost of the plastic media.

Another problem that has been reported with some media is a high or a low pH that would make it unsuitable for use on aluminum which is the primary application for such media.

Another area of concern and controversy regarding the plastic media is the potential for explosion of the dust generated in the blasting operations. Tests performed by the U.S. Bureau of Mines (BOM) under the sponsorship of the Naval Civil Engineering Laboratory (NCEL)<sup>(3)</sup> have indicated that plastic media, in itself, is relatively safe from an explosion hazard standpoint, but that the fine dust generated during its use may present some hazards. In view of the range of different chemical types of resins used to manufacture the media, significant differences in explosion characteristics might be anticipated. For instance, the urea formaldehyde and melamine formaldehyde resins are fire resistant to the extent of being essentially non-burning, and, therefore, one would expect a minimum explosion hazard from dust from those resins. On the other hand, thermoset polyesters and acrylics burn readily and should, therefore, be thoroughly tested for explosion characteristics. Thus, it appears that explosibility tests for each resin may be necessary in order to determine the level of safety of that resin.

## 2.2 Equipment and Facilities

Several manufacturers of conventional blasting equipment have recognized the opportunities with PMB. As the result, they are designing special lines of equipment to utilize PMB. Significant competitors identified to date include the following:

- Aerolyte Systems, Division of Clemco Industries (Burlingame, CA),
- Empire Blasting Equipment, Inc. (Langhorne, PA),
- Pauli and Griffin Company (Vacaville, CA),
- Schmidt Manufacturing, Inc. (Houston, TX), and
- Turco Products, Inc. (Westminster, CA).

Similarly, several companies (e.g., Caber, Inc., Seattle, WA and Blasting Division of Maltby Tank and Barge Company, Everett, WA) that have been involved in the manufacture of large-scale sand blast rooms and

facilities have been active in pursuing contracts for large PMB facilities.

Originally, some of these companies attempted to simply adapt their conventional abrasive blasting equipment for use with PMB, with less than satisfactory results. Because of the density and flow characteristics of the plastic media, it is essential that the entire unit including the feed hopper, the hoses, the nozzles, and the recycling system be designed for use with plastic media. For efficient and reliable operation, the design of the dust separation and media recycling system is particularly important. This equipment must be designed to separate large and fine particles of paint as well as fine particles of media and any foreign matter cleanly from the reusable media. Fine adjustment of the system is necessary to provide a good separation and a high recycle rate for reusable media. The air flow system in the blasting room must also be designed to assure adequate dust removal.

Most of the equipment companies supply small-scale units that can be used in the open or within temporary enclosures such as plastic film walls. These smaller units have capacity of 50 to 250 pounds of plastic media in the feed hopper. Some of these units include a vacuum pickup system that can be used to draw the media from the floor through a coarse screen to remove large paint particles and then through a tuneable dust separator to remove fines before returning the media to the hopper. Some of the dust separators are conventional cyclone separators with special controls to provide an accurate separation of the dust and fines from the usable media. Other systems use a wet collector in which the dust is collected in water.

These self-contained units are efficient and useful for testing the capabilities of PMB on different types of materiel as well as for field depainting of materiel.

Some of these small-scale portable units even provide for a closed circuit blasting operation. The blast nozzle on these units is surrounded by a larger diameter vacuum tube which has a brush on its end to provide an air seal against the surface being blasted. The media comes out of the nozzle, impacts the surface, and is drawn back along with the removed paint through the vacuum system into a separator. The disadvantage of this type of unit is the fact that the actual point of impingement of the media on the surface that is being depainted is hidden from the operator's view by the vacuum tube and brush seal.

As with all other aspects of PMB, the equipment is still in an evolutionary stage; and further improvements will doubtless occur as greater knowledge of PMB technology is generated.

### 2.3 Implementation by U.S. Air Force and Navy

Because aircraft have been the primary application for PMB, the U.S. Air Force, Navy, and Marine air arms have been particularly vigorous in pursuing plastic media blasting. The first full-scale military installation for depainting aircraft with PMB started operation at Hill Air Force Base in 1985. That installation was viewed as a prototype

facility, and improved facilities are currently under construction at Hill Air Force Base, Air Logistics Center (ALC). Thus far, PMB is approved for production use only on the F-4 aircraft, although several other aircraft are being evaluated for PMB use<sup>(4)</sup>. Additional PMB facilities are planned for several other bases including the ALCs at McClellan Air Force Base and at Warner Robins Air Force Base (Warner Robins, GA).

Although the initial results in terms of cost effectiveness and reduction of hazardous waste in replacing chemical stripping of Air Force aircraft with PMB have been very promising, tests performed to determine the possibility of damage to both aluminum and composite substrates by PMB, have raised some serious questions. These questions, which are currently under intensive study, have produced considerable divergence of opinion within the Air Force on the ultimate value of PMB. In order to resolve some of these questions and to gain additional information, the Air Force currently has in progress a number of follow-on programs as indicated in Table 2-2.

The Navy also has an extensive program on PMB including production and/or test facilities at the Naval Air Rework Facilities (NARFs) at Cherry Point, NC; Jacksonville, FL; Pensacola, FL; North Island, CA; and Alameda, CA. The Navy has undertaken an economic analysis<sup>(5)</sup> as well as general data collection on PMB<sup>(3)</sup>.

#### 2.4 Commercial Use

PMB is presently being used commercially quite widely but on a limited basis, primarily for aircraft depainting<sup>(6,7,8,9,10)</sup>. The most significant use is an installation for PMB paint removal on DC-9 aircraft at Republic (now Northwest) Airlines in Atlanta, GA. This facility was started up in 1985 and has proven to be extremely efficient, not only in terms of the reduced man-hours (and reduced hazardous waste) as compared with chemical stripping, but also on the basis of quicker turnaround of the aircraft. The use of PMB reduced by two days the length of time that the aircraft was out of service for repainting, and the airline calculates the value of each additional day of aircraft service at approximately \$35,000.

Other airlines also have more limited installations for doing wheels and other components but not an entire aircraft. These airlines include: United Airlines in San Francisco, CA and Western Airlines (now Delta) in Los Angeles, CA.

Data from the literature equipment suppliers indicate other users. The Boeing Military Aircraft Company has two Aerolyte Clemco units at their Wichita (KA) plant for use in testing PMB but have not fully accepted it at the present time. Boeing Vertol (Philadelphia, PA) has installed a system in which they have gained significant experience in depainting Chinook helicopters on military contract<sup>(8)</sup>. McDonnell Douglas is evaluating PMB for possible use on the Apache helicopter which they are overhauling; the commercial division of McDonnell Douglas at Long Beach, CA is also running tests at the present time. Bell Helicopter in Fort Worth, TX is also evaluating PMB for use on helicopter overhaul.

TABLE 2-2

U.S. AIR FORCE FOLLOW-ON TESTING PROGRAMS

<u>Performing Contractor</u>	<u>Program Objectives</u>	<u>Anticipated Completion Date</u>
BCL	(I) Effects of PMS on Thin Skin Metal (II) Media Separation Technology	June 1987
BOEING	(I) Minimum Damage to Test Specimens (II) (A) Repetitive Paint Removal (B) Evaluate Thin Skinned Honeycomb (C) Evaluate Corrosion Effects	December 1987
GD	Effects from Six PMS Cycles on Materials	February 1988
NMER	Waste Treatment Methods	September 1987
AFWAL	Graphite/Epoxy Composites	December 1987
SWRI	(I) Automated PMS System (F-4/F-16) (II) Testing & Validation at SWRI/OO-ALC (III) Technology Transfer & Benefit Tracking	December 1987

---

BCL: Battelle Columbus Laboratories (Columbus, OH)

BOEING: Boeing Military Aircraft Company (Wichita, KA)

GD: General Dynamics Corporation (Fort Worth, TX)

NMER: New Mexico Engineering Research (Albuquerque, NM)

AFWAL: Materials Laboratory Wright-Patterson Air Force Base  
(Dayton, OH)

SWRI: Southwest Research Institute (San Antonio, TX)

Source: Arthur D. Little, Inc.

### 3.0 DEPAINTING PRACTICES AT VARIOUS U.S. ARMY DEPOTS

The following are brief summaries of the information gained on depainting operations at the various U.S. Army depots contacted in connection with this program. The memoranda containing more detailed information on each of the depots are included in Appendix A as was previously noted.

#### 3.1 Anniston Army Depot

The primary mission of Anniston Army Depot (AAD), Anniston, AL, is tank overhaul with much of their depainting work done on tank hulls and large parts of tanks. They also do a significant number of milvans, containers, and some electronic shelters. Historically, most of these have been depainted with sand blasting. However, because of OSHA concerns about respirable silica dust, they have switched to a new peridot-based abrasive, trade named Green Lightning®, in place of sand. Many parts are also blasted with copper slag grit. However, the copper slag can leave a residue which kills the action of phosphatizing baths which are used as a prepainting corrosion protection treatment on some parts. Therefore, copper slag grit use is restricted to parts that are not phosphatized. For parts that require a softer blast media, they use walnut shells in both cabinets and blast rooms.

They have found that since chemical agent resistant coating (CARC) systems have been utilized, the paint removal time is increased by about one-third. The cleaning of small parts is done in chemical dip tanks and in cabinets with peridot, glass bead, or walnut shell abrasives. In the dip tank depainting operations, they use phenolic strippers which are being replaced with methylene chloride/formic acid strippers. In order to upgrade this operation, paint sludge removal from the liquid in the dip tanks by centrifugation is under study. A centrifuge will be installed later this year following successful use of a centrifuge to remove paint waste from the water wash spray booth system.

For the cleaning of small parts where aggressive blasting is permissible, centrifugal shot blast machines are used. Small arms parts are chemically degreased followed predominantly by abrasive blasting with peridot or glass beads.

The AAD primary blast facilities include nine blast rooms: three for tank hulls which utilize copper slag, two with walnut shells, three with peridot, and one with silica sand. The abrasive utilization of AAD is approximately as follows:

- Sand: 200 bags per month (100-pound bags),
- Slag: 130 tons per month plus 230 bags per month (100-pound bags),
- Green Lightning®: 1,300 bags per month (100-pound bags),

- Steel shot:
  - size 70, 1/2 to 1 ton per month,
  - size 330, 100 bags per month (100-pound bags),
  - size 125, 15 bags per month (100-pound bags),
- Walnut shells: 300 bags per month (50-pound bags), and
- Glass beads:
  - size 7, 200 bags per month (50-pound bags),
  - size 8, 200 bags per month (50-pound bags).

Currently, they are evaluating the use of an 800°F salt bath for de-painting some of the steel parts. The equipment is supplied by Kolene Company located in Memphis, Tennessee.

On the electronic shelters done at AAD, they find it is faster and more economical to strip out all the wiring on the inside so that the entire shelter can be blasted inside and out with abrasive media rather than leaving some wiring in and hand sanding the interior as is done at some other depots (e.g., Sacramento and Tobyhanna).

AAD has run tests with U.S. Technology's Polyplus® and Polyextra® plastic media. They obtained sufficient plastic media for use in one of their walnut shell blast rooms. However, they were not able to adjust the exhaust ventilation to allow recycling of the plastic media. Rather, the media all went into the dust collectors. In general, they found that the depainting efficiency of the PMB was about the same as that of walnut shells.

Some additional tests were also run in cabinets. Although some recycling was obtained, they found that the plastic media degraded very rapidly and had very low paint removal rates compared with the glass beads normally used in the cabinets. Because of the high cost of the plastic media, they did not feel that it is a promising alternative to any of their currently used blasting media.

With regard to depainting waste disposal, the large volume of spent media has been tested for EP toxic leachables and found to be below the hazardous limit so that the materials can be landfilled as a non-hazardous waste at a minimal cost. They are concerned that a recyclable media such as plastic would tend to concentrate the toxic constituents in the waste and increase the leachables to the point where the waste would be hazardous and become a significant disposal problem.

### 3.2 Corpus Christi Army Depot

The primary mission of Corpus Christi Army Depot (CCAD), Corpus Christi, TX, is the overhaul of helicopters. Prior to 1978, CCAD utilized a phenol/cresol-based paint stripper for the entire helicopter airframe using spray application and water rinse. In 1978, the phenolic stripper was banned, and they started using a methylene chloride/formic acid

stripper. This type of stripper is also used in dip tanks for depainting small airframe components and engine and transmission parts.

The blasting facilities at CCAD include cabinets in which they use steel shot, glass beads, walnut shells, or sand as the media. They also have several large centrifugal steel shot blasting machines.

Walnut shells were evaluated for depainting airframes but were found to be too aggressive on the thin metal used on many parts of the airframe. The walnut shells were also very dusty and considered an explosion hazard.

The materials that are being stripped range from 2024 alclad aluminum sheet to titanium sheet, epoxy fiberglass and epoxy Kevlar® composites along with some boron and graphite-based composites. Portions of the airframe also include steel tubing and steel flanges.

The primary paint system that has been used on the airframes in the past was an acrylic topcoat over an epoxy primer. As of January 1986, CCAD switched almost entirely to a CARC polyurethane formulation which is more difficult to remove than the acrylic-epoxy paint system. They have found that CARC paints require about three times the amount of chemical stripper than that used to remove the acrylic-epoxy paint system. Because of the durability and resistance to depainting of the CARC, it has been proposed that complete stripping and repainting is no longer needed at every overhaul. On the other hand, there are strong indications that many field commanders will not accept an aircraft as fully overhauled if it is not totally repainted.

In addition to the CARC on the airframe, a phenolic-epoxy paint is now being used on the gear boxes of the helicopters. This is even more resistant to stripping than the CARC and can not be removed by walnut shell blasting alone. The only procedure currently available is to soften the paint in a stripping bath and then blast it to remove the paint with either walnut shells or plastic media.

CCAD processes a number of containers used to ship spare helicopter engines and transmissions to the field. Historically, the containers were prepared for repainting by hand grinding and sanding which is a very laborious process. At the present time, CCAD is installing a blast facility which is scheduled to be on-stream in mid-1987 which will use DuPont Starblast®, staurolite abrasive for the containers.

Because of the intense pressure to move away from phenolic and even methylene chloride strippers, CCAD started evaluating plastic media blasting in 1984. A small blast unit was obtained and modified so that PMB trials could be run on OH58 helicopter airframes. Twenty-eight airframes were stripped using PMB to provide data to determine whether or not a PMB facility could be justified. On these airframes, the depainting was done only on the fiberglass epoxy skin which is 40 percent of the total area of the airframe. The aluminum skin was chemical stripped because there was inadequate data on the effect of PMB on the aluminum. As a result of the success of this test, CCAD has contracted for a permanent PMB facility which will be 30 feet by 65 feet by 24 feet in

height which is scheduled to be ready for use in the fall of 1987. They plan to use U.S. Technology Polyplus® media. In the meantime, additional PMB is being done in a temporary facility to facilitate production.

### 3.3 Letterkenny Army Depot

Letterkenny Army Depot (LEAD), Chambersburg, PA, has diverse assignments in the overhaul of vehicles, artillery, and radar units. They have blast rooms which utilize steel shot, glass beads, and walnut shells as blast media. In addition, they have a number of centrifugal blast machines that utilize steel shot for paint and corrosion removal from various small parts. They also have numerous blast cabinets and they have one PMB blast room which is approximately 13 feet by 16 feet by 12 feet in height. At LEAD, all of the media (steel shot, glass beads, walnut shells, and plastic beads) are recycled.

LEAD has been active in evaluating the value of PMB in comparison with walnut shell blasting. They have found that although plastic media may be cost effective under some conditions, in the practical scenario, total substitution of PMB for walnut shell blasting would increase costs by \$150,000 to \$300,000. This report is included in Appendix D.

From the standpoint of hazardous waste disposal of depainting waste at LEAD, tests indicate that the spent media (regardless of its type) is sufficiently high in heavy metals that it must be classified as hazardous waste. In 1986, they disposed of over 1.5 million pounds of waste at a cost of \$0.36 a pound for a total cost of approximately \$540,000.

### 3.4 Lexington/Bluegrass Army Depot

At Lexington/Bluegrass Army Depot (LBAD), Lexington, KY, the primary mission of the Maintenance Directorate is the overhaul of shelters, milvans, and trailers. There is a tenant operator doing work on shelters and trailers in parallel with the work of depot personnel. The depot personnel depaint by sand blasting and hand sanding. The tenant operator is evaluating the use of PMB using a portable unit purchased for \$13,000 and located in an enclosure built on site with appropriate air circulation and filtering equipment added. They are using Polyplus® 12-20 mesh media. The PMB is providing a cost saving of up to 30 man-hours per van over the alternative of hand sanding; the tenant operator does not have a van-size sand blast facility.

The workload is low at LBAD, and the total depaint waste disposed of last year was about 35 drums at a cost of about \$17,000.

### 3.5 Red River Army Depot

The primary mission at Red River Army Depot (RRAD), Texarkana, TX, is the overhaul of the M113 family of personnel carriers and the new Bradley fighting vehicle. They also refurbish a small number of milvans and missile containers. They have approximately 50 cabinets which use a wide range of media including sand, steel shot, walnut shells, and glass beads. They have two large vehicle booths and four additional blast rooms, all of which currently use sand. However, they are planning to

switch these rooms to peridot-based abrasive because of OSHA regulations on sand use. They also have several steel shot blast machines of the centrifugal type.

The hulls of the personnel carriers are heavy aluminum which can be blasted with aggressive media such as sand or peridot. Steel shot cannot be used because it leaves steel smears on the aluminum which would initiate corrosion.

Some of the current blast rooms will be abandoned in 1987 when production starts in a new building in which disassembly, cleaning, painting, and reassembly operations will be consolidated under a single roof. This new building is 250 feet by 750 feet and costs about \$50 million. It has two blast rooms and also a large bay for automated blasting of vehicle hulls. In this bay, the hull is picked up and held vertically while being centrifugally blasted with stainless steel shot. Stainless steel is acceptable as a blast medium for the aluminum. However, there are concerns about the durability of the stainless steel shot which costs over \$2 per pound.

RRAD has evaluated plastic media in cabinets only. They find that the removal rate is better than with walnut shells but significantly less than with sand. They believe that plastic media at \$2.15 per pound is unlikely to be cost competitive with sand at \$40 per ton. In the cabinet trials that were carried out, plastic media appeared to degrade at a high rate.

With regard to the generation of hazardous wastes, the sand from blasting rooms is not recycled, and it passes the EP Toxicity test so that it can be landfilled as a non-hazardous waste. However, the dust from the sand blasting operations has sufficient chromate content to be classified as hazardous. The dust is mixed with sludge from the electroplating operations and is disposed of as a hazardous waste. Under the previous contract, the cost for hazardous waste disposal was \$85 per ton; under the current contract, it is \$153 per ton. From September 1985 through October 1986, a total of approximately 120 tons of hazardous dust was generated for disposal.

### 3.6 Sacramento Army Depot

The primary depainting work at Sacramento Army Depot (SAAD) is electronic shelters. The exterior of the shelters is sand blasted while the interior is hand sanded.

SAAD personnel believe that PMB fits well with the electronic equipment they worked on. Some experimental work done there indicates that PMB can be used not only on shelters but also on encapsulated printed circuit boards and even for the removal of silicone rubber on sensitive night vision instruments. They have even found that PMB can be used effectively on stainless steel surfaces which tend to warp very easily because of their low thermal conductivity.

Eighty to eighty-five percent of the material depainted at SAAD is aluminum on which they believe PMB can be very cost effective. This is because PMB can be used on the interior of the electronic shelters without damaging the wiring, connectors, vents, and other delicate components. The high labor cost of hand sanding the interior gives plastic media blasting a cost advantage over the current exterior sand blasting and interior hand sanding.

As a result of their experience in trial tests, SAAD is planning to install a PMB vehicle-size booth which will be 36 feet by 32 feet by 15 feet in height. They expect to award the contract for this booth in August 1987 and anticipate a 12-month construction period.

From a hazardous waste standpoint, the sand blasting operations generate over 300 tons per year of spent sand which is not classified as a hazardous waste based on EP Toxicity tests. The leachability of toxic constituents (e.g., heavy metals) is low because the sand is not recycled in the blasting operation. In spite of the fact that the spent media is non-toxic, it is increasingly difficult to dispose of it because of severe restrictions on the creation of new landfills. To further complicate matters, the spent media from sand blasting is now classified as a special waste in California, and there is concern that it may eventually be classified as a hazardous waste regardless of EP Toxicity test results. If this happens, there will be a great advantage to PMB because of the reduced volume of spent media compared with sand.

### 3.7 Tobyhanna Army Depot

The work at Tobyhanna Army Depot (TOAD), Tobyhanna, PA, is almost entirely on electronic equipment with the depainting operations primarily involving communication and electronic shelters, milvans, trailer generators, etc.

Most of the current depainting at TOAD is done by hand sanding. They believe that this is more efficient because in most cases they can selectively remove the paint. They have found that blasting is difficult to control and requires a higher skill level than hand sanding. Also, when blasting is used, much of the existing sealant is removed and, therefore, has to be replaced by the sheet metal workers. However, they recognize that blasting is faster than hand sanding and must be used in order to keep up with the workload.

In two different buildings, they have 15 foot by 15 foot blast rooms. One of these was previously used primarily for steel parts and was charged with steel shot. However, that room has now been converted to aluminum oxide media in anticipation of an increased workload for blasting aluminum shelters. However, this change has proved controversial because the increased workload for shelters has not developed, and they find that the quantity of aluminum oxide consumed is much greater than was the case with the steel shot. All of the blasting at TOAD in the blast rooms and in the cabinets is done with aluminum oxide. They also have a centrifugal blast machine that uses No. 50 steel shot.

One adverse cost factor in using the blast rooms is that safety regulations require one man outside observing the man that is blasting inside, regardless of the media employed. As a result, they have to pay for two man-hours of work for each hour that a room is in use.

The total quantity of depainting waste that is produced at TOAD is small. It is assumed that this waste is hazardous and is drummed and disposed of as such in an appropriate off-site hazardous waste landfill.

### 3.8 Tooele Army Depot

The mission at Tooele Army Depot (TEAD), Tooele, UT, includes maintenance and overhaul of trucks, engines, transmissions, axles, generators of several sizes and types, multipurpose power units for supplying heat and air-conditioning, and portable shelters. Large parts that have to be repainted are steam cleaned and then blasted with steel grit. For the more delicate parts of aluminum and other soft metals, the blasting is done with walnut shells with which aluminum oxide is sometimes mixed to provide a slight increase in aggressiveness for the removal of corrosion as well as paint. The total amount of media of all types utilized at TEAD was approximately 250,000 pounds in 1986.

TEAD personnel have been following the development of PMB and have run several trials with PMB in cabinets and also on a truck that they had sent to Hill Air Force Base for a blasting trial. They report that the recycle rate on the plastic media seemed to be very low, and it did not appear that the paint removal rate was any greater than when walnut shells were used. In addition, further work was necessary on the truck after paint removal to remove corrosion that was not touched by the plastic media. The trials, therefore, did not indicate that the plastic media would be cost effective.

The dust from the blasting operations at TEAD is classified as a hazardous waste. In Fiscal Year 1986, the hazardous waste disposal included 210 drums of steel dust and 556 drums of walnut shell dust at a unit cost of \$50 per drum. However, that contract was terminated, and future contracts are estimated to be \$65 to \$85 per drum for disposal.

#### 4.0 KEY ISSUES SURROUNDING PMB

As a result of the survey of the state of the art in PMB and in depainting practices at the various depots, several key issues have emerged which may ultimately affect the cost effectiveness of PMB.

##### 4.1 Environmental Regulations

The determination of whether a depainting waste is a hazardous waste is of critical importance because of the costs and problems associated with disposing of hazardous waste. These problems will increase substantially in the 1990-1992 time frame when the disposal of hazardous wastes in landfills will become severely restricted by EPA regulations that are currently being formulated under a mandate from Congress. The method of disposal then is a matter of conjecture. Certainly, at that point, if it has been found that spent plastic media and paint dust can be incinerated under appropriate conditions, it would be possible to reduce the amount of hazardous waste to a minimum (residual ash) and thereby reduce the disposal problem.

Of more immediate concern with regard to the relative economics of PMB versus alternative abrasive blast media, which are recycled to a lesser extent or not at all, is the toxicity of the blasting waste. Current EPA regulations state that if the leachable heavy metals content, as determined by the current EP Toxicity test (40 CFR 261.24), exceeds certain values, the waste is hazardous. The primary metals of concern in the depainting waste are chromium and lead which must not exceed five parts per million each and cadmium which must not exceed one part per million. Several of the depots using large volumes of sand and even some using walnut shells find that the spent media waste is not toxic according to the current EP Toxicity test so that the material can be landfilled as a non-hazardous waste. Under those circumstances, the economics favor the low cost abrasive media. However, if the EPA heavy metal limits should be lowered such that the spent media becomes a hazardous waste, disposal would be a severe problem because of the large quantity of waste. In that case, PMB would offer a significant advantage.

Investigation of the EPA requirements indicates that a change in the EP Toxicity test to a new test designated the Toxicity Characteristics Leaching Procedure (TCLP) is likely to occur in 1988. The TCLP test may pick up some heavy metal content that does not show up in the current test thus, in effect, lowering the limits slightly. However, it is unlikely that this change will significantly affect the classification of blast residues.

Inquiries indicate that further changes to lower the limits for the heavy metals are possible but not specifically anticipated as of this time. It, therefore, appears that there will not be an incentive in the immediate future to change to PMB from current methods using low cost aggressive blast media and walnut shells in those cases where the blast residue is not now classified hazardous. However, potential changes in the regulations should be constantly monitored because a

change that would make those residues a hazardous waste would significantly change the economics of those processes versus PMB.

#### 4.2 OSHA Regulations

Several OSHA regulations have a bearing on the use of PMB. The first is the pressure to reduce or discontinue use of methylene chloride-based strippers because of the listing of methylene chloride as a potential carcinogen<sup>(1)</sup>. Due to OSHA and EPA requirements, the use of chemical strippers on aircraft and other large components is rapidly being discontinued. However, most of the depots still use methylene chloride dip tanks for small parts. Because of the status of methylene chloride, it is likely that the use of such baths will be discouraged and/or their use will become inconvenient and more costly due to increased ventilation and protective clothing requirements. As this happens, the possibility of using automated PMB blast machines for small parts would become much more attractive. However, some depot personnel are concerned about lower productivity if stripper dip tanks are abandoned, and these concerns must be addressed.

Another OSHA regulation that is having a significant impact on blast depainting practices is the banning of sand blasting due to the problems of silicosis from respirable silica. However, the depots appear to have this situation in hand by going to other mineral-based abrasives which are slightly more expensive but still much lower in cost than plastic media.

The third OSHA regulation that is impacting blast depainting practices concerns the use of organic blast media. Their use is being restricted by regulation to automated rooms because of the potential explosion hazard with the organic dust (29CFR, Chapter XVII, subpart G Section, 1910, a(2)iii). This rule was adopted at a time before the development of plastic media when all organic media were natural products which generate a large amount of potentially explosive dust. Exceptions to this rule are possible for rooms that have adequate ventilation to control dust buildup, and this allows continued manual blasting with walnut shells. If this regulation is strictly interpreted, plastic media which are also organic in nature would fall within its scope. However, PMB users have already been discussing the differences between plastic and agricultural media with OSHA, and a change in the regulation has been proposed to differentiate plastic media from agricultural media because of the much lower dust generation and, therefore, lower hazard potential with plastic media.

#### 4.3 Substrate Damage

Within the Air Force and among other PMB users, there is considerable controversy regarding the question of substrate damage during paint removal with PMB. There are several types of damage that are of concern; the major ones are discussed below.

#### 4.3.1 Cladding Removal

One of the areas of concern is that the cladding on alclad aluminum sheet will be removed by the plastic media blasting. Tests have been run by several facilities to determine the degree of cladding removal, and it now appears that although some cladding is removed, that this represents less than 25 to 50 percent of the total clad layer after several paint removal cycles. Proponents of PMB argue that less cladding is removed by PMB than is removed by hand sanding that is sometimes used following paint removal by chemical stripping techniques.

#### 4.3.2 Fatigue Crack Masking

Another concern that has been expressed is that the plastic media blasting will move the aluminum cladding on the surface sufficiently to cover and mask fatigue cracks that might otherwise be detected. Although some testing has been done to indicate that such masking is not a problem, the issue is still not fully resolved.

#### 4.3.3 Crack Initiation

A study<sup>(11)</sup> sponsored by the Corrosion Office at Warner Robins Air Force Base indicates that occasional small pits are evident in the surface of aluminum following plastic media blasting. Sophisticated analytical techniques have indicated that foreign metals or silica are frequently present in these pits. The indications are that the pits may be caused by foreign particles in the plastic media. Since some of these pits were present even in metal that was blasted only with virgin plastic media, it appears that some foreign materials may have been present in the plastic media as manufactured. In any event, the possibility of picking up such foreign materials is greater in the recycled media.

Studies are currently underway to improve the systems for cleaning the media as it is recycled to more fully eliminate all foreign matter thus reducing the possibility of pits which act as stress risers and can initiate fatigue cracks. Opponents of PMB cite the pit problem as one which can be solved only through much more complex equipment for handling the plastic media which is going to make installations considerably more expensive and difficult to maintain and will require constant attention to assure that the media is properly cleaned. The proponents of PMB tend to dismiss the seriousness of pits indicating that more serious stress risers are created by the hand sanding that is done following chemical stripping than the pits produced by PMB.

#### 4.3.4 Fatigue Life Reduction

Additional tests<sup>(11)</sup> that have been performed under the sponsorship of the Corrosion Office at Warner Robins Air Force Base indicate that in all cases, some reduction of fatigue life results from the plastic media blasting. In the case of aluminum sheet that is over 0.065 inch thickness, the reduction is generally 25 percent or less and is not considered serious. However, thinner aluminum sheet, particularly that in the thickness range below 0.030 inch, has shown fatigue life reductions of up

to 90 percent. Additional work is currently underway to further study the question of severely reduced fatigue life.

#### 4.3.5 Composite Substrates

Work done at the Air Force Materials Laboratory at Wright-Patterson Air Force Base, reported verbally at the Tri-Service Coatings Removal Conference at San Diego in January 1987, indicates that high performance aramid and carbon fiber composites may be significantly damaged by PMB. Further work is currently in progress in an attempt to resolve the questions concerning composite damage by PMB.

#### 4.4 Non-Aircraft Applications of PMB

Considerable work has been and is currently being done to generate data on the efficiency, the cost effectiveness, and the problems of using PMB on aircraft. However, with the exception of CCAD, most of the work at Army depots involves non-aircraft applications where abrasive blasting rather than chemical stripping is the primary depainting method. In these situations, the cost effectiveness of PMB is much less apparent, and in many cases, PMB alone is not suitable because of metal finish requirements. Further study is needed to identify specific situations in which PMB will be cost effective on these other types of materiel.

One potential application is shelters where PMB is already planned or used by SAAD and LBAD personnel. However, there are questions raised by the fact that the depaint waste from PMB processing usually is a hazardous waste whereas the residue from sand blasting is not a hazardous waste and can, therefore, be landfilled at a lower cost. The overall cost effectiveness of PMB for shelters must, therefore, be assessed in further detail.

Another potential application for PMB is the more delicate louvers and thin metal parts on shelters, generators, and other types of equipment. Here testing must be done to determine whether these parts are too delicate even for plastic media blasting.

Another possible application for PMB is on aluminum that has an alclad surface which cannot be sand blasted without removing the cladding. For example, some road wheels for personnel carriers are made of clad aluminum. Currently, these wheels are abrasive blasted. The blasting removes the cladding as well as the paint, and the wheels must be replated with aluminum before repainting. PMB might be cost effective in this application due to elimination of the need for replating.

As was previously noted, methylene chloride stripper dip tanks are still being used for many small parts. Because of the potential hazard from methylene chloride and also the waste disposal problem with both the paint sludge and the methylene chloride bath when it is changed, automated small parts PMB blasting is a potential alternative. Several companies that manufacture automated blasting equipment have indicated that their designs can be adapted for use with PMB. These machines not only can provide positive hold down for the small parts as they pass under properly arrayed blast nozzles, but also in some cases can even turn the

part so that both sides are automatically blasted without being touched by human hands.

Trucks and other support equipment have been depainted with PMB but recently reported results indicate that PMB may not be competitive with walnut shell or sand blasting. Additional work is needed to provide a definitive answer on these types of materiel.

Additional potential applications of PMB will have to be identified by a more detailed analysis of the various items handled by each depot.

#### 4.5 Economics of PMB

Economics of PMB can be examined on the basis of both capital and operating costs.

##### 4.5.1 Capital Costs

As has already been shown by trial runs at several U.S. Air Force and Army depots, a facility that is to use PMB efficiently must be designed from the start for PMB use. Conversion of facilities originally designed for other types of blasting is likely to prove inefficient. Experience has also shown that it is important that a PMB facility be designed and constructed by firms knowledgeable in the intricacies of PMB operations. Both in the military and civilian sector, some disappointing results have been reported because low bidders were selected who were not familiar with the design and construction requirements for PMB facilities.

Several large facilities at various military installations are currently being planned or actually under contract and/or construction. A list of these to show typical capital costs are included in Table 4-1. These are all turnkey facilities. For purposes of comparison, the cost of the hanger used for chemical stripping at Hill Air Force Base which has full atmospheric control is also shown in Table 4-1.

##### 4.5.2 Operating Costs

Several studies that have been performed to compare the costs of PMB with chemical stripping show that PMB is far more efficient. These include reports by Accurex<sup>(12)</sup>, Hill Air Force Base<sup>(4)</sup>, and NCEL<sup>(5)</sup>. In all cases the operating cost associated with PMB is much less than that of chemical stripping. However, the more important comparison for the majority of the Army depots is between PMB and other blasting processes. As we previously noted, LEAD carried out a detailed comparison of the costs of walnut shell blasting versus PMB and concluded that the walnut shell blasting has a cost advantage over PMB for most practical scenarios. Similarly, evaluations by AAD and RRAD indicated that PMB was not competitive with current blasting methods. The LEAD, AAD, and RRAD reports are included in Appendix D. As has been previously noted, the conclusions in these reports are based on current disposal costs for the depainting wastes. If anything happens to change the classification of those wastes, then the entire economic picture can change

TABLE 4-1

PMB FACILITY CAPITAL COSTS

<u>Location</u>	<u>Physical Dimensions</u>	<u>Estimated Capital Cost (\$)</u>
Sacramento Army Depot	36' x 32' x 15'	300,000
Corpus Christi Army Depot	60' x 30' x 30'	800,000
McClellan Air Force Base	92' x 90' x 25'	924,000
McClellan Air Force Base	72' x 35' x 17'	400,000
McClellan Air Force Base	24' x 12' x 10'	140,000
Hill Air Force Base	40' x 30' x 15'	86,000
Hill Air Force Base	70' x 58' x 25'	500,000
Hill Air Force Base Chem Strip		3,000,000

Source: Compiled by Arthur D. Little, Inc., based on data from military installation facilities personnel.

significantly since one primary component of the total operating cost is the cost of hazardous waste disposal.

#### 4.6 Alternative Depainting Methods

There are several alternative depainting methods that are in various stages of development that are potentially competitors with PMB. In the course of this study, these have been briefly examined to determine whether they are serious competitors.

##### 4.6.1 Xenon Flashlamp

The xenon flashlamp system<sup>(13,14)</sup> is still in a developmental stage. The capital costs are high particularly if robotization equipment for the movement of the lamp is included. Even with robotization, it is difficult to follow complex contours. Also, possible adverse effects to the substrates have not been fully studied to date. Therefore, it does not appear that xenon flashlamp techniques will represent a near-term alternative to PMB.

##### 4.6.2 Laser Depainting

The use of lasers for depainting is in an even earlier stage of development than the xenon flashlamp. Preliminary studies have been done by AVCO Research Laboratory (Everett, MA) that indicate that depainting can be accomplished with a laser. However, no quantitative evaluations have yet been completed. The report on this work is not yet available.

The use of lasers will undoubtedly involve a very high capital cost particularly since a sophisticated control system will be needed to automate and control the laser depainting process. Also, possible damage to substrates has not been evaluated as yet.

##### 4.6.3 CO<sub>2</sub> Pellet Blasting

Although this process has been under development for a number of years, it is still not fully operational. Available verbal information from Lockheed Corporation, the developer, indicates that there are continuing problems with equipment. There are specific difficulties in assuring that the pellets do not freeze together to form large agglomerates which could either block the system or cause damage to the material being blasted. There are also questions as to whether the shock cooling that might be induced by the CO<sub>2</sub> pellets would cause any damage to the substrate.

##### 4.6.4 Molten Salt Bath

There is technology now available that involves immersing the parts to be depainted in a molten salt bath to thermally degrade the paint which can then be easily removed. Current indications are that the salt baths can be used only with certain type parts because of the high temperatures (800-1200°F) involved, and the size of the parts that can be treated is limited by the size of the salt bath. Therefore, the

technique appears to be effective for a limited size and range of types of parts and could be a competitor to PMB for some parts.

#### 4.6.5 High Temperature Air Bake

There are several types of high temperature air bake equipment available. Some simply involve immersion of the part in air of sufficient temperature (600-1200°F) to pyrolyze the resin in the coating. Other systems immerse the part in a heated fluidized bed where the fluidized medium is an abrasive which provides improved heat transfer and mild abrasion of the surface to remove the paint as it is decomposed. This type of bath can operate at a somewhat lower temperature (500-600°F) than techniques that simply provide a high temperature soak because of the mild abrasive action of the fluid bed on the part. These high temperature bake systems represent a potential competitor for PMB on a limited range of sizes and types of parts which can withstand these temperatures.

## 5.0 RECOMMENDATIONS FOR IMPLEMENTING PMB

Because of the many key issues surrounding PMB that are as yet unresolved, a test program should be implemented to evaluate the effectiveness of PMB on different types of U.S. Army materiel that appear to be candidates for this type of paint removal process. The PMB data obtained in such a test program would provide a database that could be used by all depots as a resource to indicate when PMB can be effectively used. In addition, the establishment of an information clearing house for depainting should be considered. This unit could maintain and update the PMB database and extend it to all depainting methods. The resulting data bank would provide a valuable resource for U.S. Army depots in the field of depainting.

### 5.1 Test Plan

The use of PMB on aircraft is under intensive study by the U.S. Air Force, Navy, and Army CCAD personnel; therefore, aircraft applications are excluded from this test plan. However, during the proposed test program, liaison should be maintained with those personnel carrying out the aircraft studies so that data generated in those programs can be included with the PMB data generated in this test program.

In order to further evaluate the effectiveness of PMB on specific types of materiel, a PMB pilot facility should be set up in which tests can be carried out to determine the effectiveness of PMB for other than aircraft applications as a competitor to alternative blasting methods and media.

The items of materiel to be blasted should be determined through detailed discussions with depot personnel to identify specific items that can be most cost effectively depainted with PMB. Such items include parts with permanent protective coating such as alclad parts, components made of thin metal that could be damaged by more aggressive blasting, a variety of types of small parts that are now handled through methylene chloride dip tanks which might be better processed on automated PMB blast equipment, and aluminum sheet structures such as shelters.

In addition to evaluating the efficiency of PMB on different types of materiel, an evaluation should also be made of the various currently available plastic media to determine differences in the characteristics and efficiency of the variety of materials that are now available.

The study should also include evaluation of the effects of blasting parameters such as air pressure, impact angle, and nozzle distance from the work surface on the paint removal rate and media degradation rate.

### 5.2 Depainting Clearing House

Personnel at several of the depots visited indicated the need for a resource center where up-to-date information on various types of depainting procedures and recommendations for their use could be obtained. This center could monitor developments in depainting through

literature search and contact with manufacturers of materials and equipment for depainting, coordinate tests at different depots to evaluate different depainting methods, and distribute results of such tests to the depot system. Where appropriate, this center might initiate test programs to evaluate the effectiveness of new depainting techniques for various applications within the depot system.

The importance of efficient depainting practices to the depots cannot be over emphasized. Several of the depot personnel pointed out that depainting is frequently a bottle neck in depot operations with several hundred personnel involved in depainting controlling work flow to several thousand other employees.

## 6.0 TEST PLAN FOR PMB EVALUATION

This test plan was developed based on discussions with USATHAMA, DESCOM, and U.S. Army depot personnel. The test program will be conducted at Letterkenny Army Depot (LEAD) by Arthur D. Little, Inc. and Army LEAD personnel. This test plan includes a discussion of the program's objectives and approach, test procedures to be followed, test matrix, data sheets, Army depot responsibilities, evaluation criteria and related topics.

### 6.1 Overall LEAD Test Program

#### 6.1.1 Objective

The objective of this test program is to initiate the building of a data base on PMB that can be used as a resource by U.S. Army depot personnel to identify potential areas of application of PMB in their operations.

In all cases, available data on current methods of depainting will be compiled (to the extent possible) for comparison with the data on PMB.

#### 6.1.2 Approach

The primary effort in the test program consists of four series of tests designed to evaluate the effectiveness and efficiency of currently available plastic media in depainting various types of U.S. Army materiel. Test Series 1 will provide baseline data and evaluate the variability within plastic media blasting test results using the proposed procedures. In the second test series, different types of commercially available plastic media will be evaluated. In the third test series, the effects of changes in blasting parameters (blast pressure, media flow rate, etc.) and also the effects of conversion from conventional paint coatings to CARC paint systems on PMB depainting will be evaluated. In the fourth test series, the effectiveness of PMB for depainting different types (heavy steel, thin aluminum, etc.) of U.S. Army materiel will be determined.

Throughout this test program, every effort will be made to simulate typical depainting operations so that the data collected will be representative of actual depot working conditions.

Since the objective of the test program is to provide an initial data base on PMB for the U.S. Army depots, two areas of activity are included in addition to the actual testing effort at LEAD. One of these areas is evaluating commercially available automated equipment for PMB, particularly for small parts. The other area is the updating of data on the current status of PMB testing and use in the U.S. Air Force, Navy and commercial applications. Both of the areas are important parts of the data base which is designed to provide an overall picture of the state of the art in PMB.

### 6.1.3 Test Procedure

The general procedure for all test runs is described in this section. The specific variables for each test series are described in sections 6.2 through 6.5. An engineer from Arthur D. Little, Inc. will be on-site during the testing to oversee the test program and be responsible for ensuring test procedures are followed and all necessary data is collected and recorded properly.

A test matrix which outlines each test and the parameters to be varied for the entire test program is given in Table 6-1.

6.1.3.1 Blasting Equipment - Test Series 1, 2 and 3 will be conducted in a blast cabinet. Test Series 4 will be conducted in blast room. The cabinet to be used is one that is available on-site at LEAD but will be converted from suction to pressure feed of the media to increase control and efficiency with plastic media.

The blast room will be designed for PMB and will be installed on-site at LEAD for this test program. The cabinet and blast room will have automatic recycle systems, so the reclaimable plastic media will be continuously separated from dust and debris and returned to the feed hopper.

6.1.3.2 Materiel to be Depainted - The materiel to be depainted will be selected from those items that are available at LEAD at the time of testing. However, items will be selected to represent (to the extent possible) the full range of types of materiel depainted at the various depots. Letterkenny personnel will ensure that there is an adequate amount of materiel to be blasted.

Current plans call for Test Series 1, 2 and 3 to utilize selected groups of smoke generator and 8V engine parts for depainting. These parts are processed by LEAD in volume on a continuing basis so that the same groups of parts can be processed in each test. Table 6-2 describes the items from the smoke generator and the 8V engine which will be depainted in the tests. Test Series 4 will use containers of various sizes, shelters and M12 Decon units for depainting, as well as other large parts that are available at the time of testing. These items will be selected to be representative of the various types of materiel depainted throughout the depot system.

6.1.3.3 Test Preparation - Prior to the start of the testing, the smoke generator parts (Table 6-3) and the 8V engine parts (Table 6-4) will each be examined and measured to determine the surface area for each part. These surface areas will be utilized as standard areas for these sets of parts throughout the test program. For the large parts used in tests in the blast room, each part to be depainted will be measured to define its surface area.

At the start of each cabinet test, the feed system will be loaded with a known amount of fresh plastic media. A 100 gram sample of the media will be analyzed for mesh size using sieves and a shaker. The results will be recorded on the Media Size Log (Table 6-5).

TABLE 6-1

PILOT PMB TEST MATRIX

Run #	Test Description	Blast Location	Materiel to be Blasted	Blast Media			Nozzle		Blast Pressure (psi)	Media Flow Rate (lb/min)	Paint Type
				Vendor	Grade	Mesh	Size (in)	Angle (deg)			
1.0.0	Data Duplication	Cabinet	Smoke Generator/Bv /Small Parts	U.S. Technology	Type III	20-30	3/8	10	30	3	Conventional
1.0.1	"	"	"	"	"	"	"	"	"	"	"
1.0.2	"	"	"	"	"	"	"	"	"	"	"
1.0.3	"	"	"	"	"	"	"	"	"	"	"
1.0.4	"	"	"	"	"	"	"	"	"	"	"
1.1.0	"	"	"	Composition Materials	Plastigrit	"	"	"	"	"	"
1.1.1	"	"	"	"	Hard	"	"	"	"	"	"
1.1.2	"	"	"	"	"	"	"	"	"	"	"
1.1.3	"	"	"	"	"	"	"	"	"	"	"
1.1.4	"	"	"	"	"	"	"	"	"	"	"
2.0.0	Paint Removal/ Media Durability	"	"	U.S. Technology	Extra	12-20	"	"	"	"	"
2.0.1	"	"	"	"	"	20-30	"	"	"	"	"
2.0.2	"	"	"	"	"	30-40	"	"	"	"	"
2.0.3	"	"	"	"	Plus	12-20	"	"	"	"	"
2.0.4	"	"	"	"	"	20-30	"	"	"	"	"
2.0.5	"	"	"	"	"	30-40	"	"	"	"	"
2.0.6	"	"	"	"	Type III	12-20	"	"	"	"	"
2.0.7	"	"	"	"	"	30-40	"	"	"	"	"
2.1.0	"	"	"	Aerolyte	3.5	20-30	"	"	"	"	"
2.2.0	"	"	"	Potters	"	20-30	"	"	"	"	"
2.3.0	"	"	"	DuPont	Type C	12-20	"	"	"	"	"
2.3.1	"	"	"	"	"	20-30	"	"	"	"	"
2.3.2	"	"	"	"	Type L	12-20	"	"	"	"	"
2.3.3	"	"	"	"	"	20-30	"	"	"	"	"
2.4.0	"	"	"	MPC	Type II	20-30	"	"	"	"	"
2.5.0	"	"	"	.....Glass Beads.....	"	"	"	"	90	"	"
2.5.1	"	"	"	"	"	"	"	"	"	"	"
2.6.0	"	"	"	.....Walnut Shells.....	"	"	"	"	"	"	"
2.6.1	"	"	"	"	"	"	"	"	"	"	"

PILOT PMB TEST MATRIX (Continued)

Run #	Test Description	Blast Location	Materiel to be Blasted	Blast Media			Nozzle		Blast Pressure (psi)	Media Flow Rate (lb/min)	Paint Type
				Vendor	Grade	Mesh	Size (in)	Angle (deg)			
3.0.0	Parameter Optimization	Cabinet	Smoke Generator/8v /Small Parts	Top Rated Media in Durability Testing	3/8	80	10	30	6	Conventional	
3.0.1	"	"	"	"	"	"	"	"	9	"	
3.0.2	"	"	"	"	"	"	4	"	3	"	
3.0.3	"	"	"	"	"	"	16	"	"	"	
3.0.4	"	"	"	"	"	"	10	50	"	"	
3.0.5	"	"	"	"	"	"	"	30	"	CARC	
3.0.6	"	"	"	"	"	"	"	"	"	"	
3.1.0	"	"	"	2nd Rated Media in Durability Testing	"	"	"	"	6	"	
3.1.1	"	"	"	"	"	"	"	"	9	"	
3.1.2	"	"	"	"	"	"	4	"	3	"	
3.1.3	"	"	"	"	"	"	16	"	"	"	
3.1.4	"	"	"	"	"	"	10	50	"	"	
3.1.5	"	"	"	"	"	"	"	30	"	CARC	
3.1.6	"	"	"	"	"	"	"	"	"	"	
4.0.0	Materiel Variation	Room	Thin Aluminum Large Parts	Top Rated Media During Testing	3/8	"	"	Determined During Parameter Optimization	"	Conventional	
4.0.1	"	"	"	"	"	"	"	"	"	"	
4.0.2	"	"	"	"	"	"	"	"	"	"	
4.0.3	"	"	"	"	"	"	"	"	"	CARC	
4.1.0	"	"	Heavy Steel Large Part	"	"	"	"	"	"	Conventional	
4.1.1	"	"	"	"	"	"	"	"	"	"	
4.1.2	"	"	"	"	"	"	"	"	"	CARC	
4.2.0	"	"	Heavy Aluminum Large Part	"	"	"	"	"	"	Conventional	
4.2.1	"	"	"	"	"	"	"	"	"	"	
4.2.2	"	"	"	"	"	"	"	"	"	CARC	
4.3.0	"	"	Medium Sized Parts	"	"	"	"	"	"	Conventional	
4.3.1	"	"	"	"	"	"	"	"	"	"	
4.4.0	"	"	Medium/Small Sized Parts	"	"	"	"	"	"	"	
4.4.1	"	"	"	"	"	"	"	"	"	"	
4.5.0	"	"	Large Parts	-----Walnut Shells-----	"	"	"	90	"	CARC	
4.5.1	"	"	"	"	"	"	"	90	"	Conventional	

Source: Arthur D. Little, Inc.

TABLE 6-2

PLASTIC MEDIA BLASTING TEST PROGRAM/SMALL PARTS TESTING INFORMATION  
8V ENGINE PARTS

<u>Item Description</u>	<u>National Stock Number</u> (NSN)	<u>Part No.</u>	<u>Material</u> <u>of</u> <u>Construction</u>	<u>Paint Surface</u> <u>Area (in<sup>2</sup>)</u>	<u>Qty/Unit</u>
Air Box Cover	2815-00-159-8753	5132458	Aluminum	21	4
Air Box Cover	2815-00-159-8754	5144186	Aluminum	40	2
Fly Wheel Cover	2815-00-902-1767	5122219	Steel	10	3
Fly Wheel Cover	2815-00-986-0489	5122281	Steel	49	2
Camshaft Damper	-----	5189863	Steel	NA	1
Air Housing	-----	5136789	Aluminum	205	1
Camshaft Gear Cover	-----	5122680	Aluminum	241	1
Pulley	3020-00-217-5707	5138717	Steel	71	1
Shaft	2815-00-961-9802	5117920	Steel	21	1
Valve Cover	2990-00-443-2103	5132550	Aluminum	450	1
Valve Cover	-----	5140317	Aluminum	450	1
Damper	-----	5109863	Steel	NA	1
Fuel Strainer Shell	-----	5575893	Aluminum	NA	1
Air Intake	-----	5103041	Aluminum	495	1
Cross Over Tubes	-----	5102826	Steel	353	2
Front End Block	2815-00-855-5789	5132422	Steel	244	1

TABLE 6-2 (Continued)

PLASTIC MEDIA BLASTING TEST PROGRAM/SMALL PARTS TESTING INFORMATION  
SMOKE GENERATOR PARTS

<u>Item Description</u>	<u>National Stock Number (NSN)</u>	<u>Part No.</u>	<u>Material of Construction</u>	<u>Paint Surface Area (in<sup>2</sup>)</u>	<u>Qty/Unit</u>
Oil Pump Cover	1040-00-659-5174	C31-15-1238	Aluminum	15	1
Shroud	1040-00-659-5167	C31-15-1233	Aluminum	27	1
Oil Dis. Separator	1040-00-659-5180	C31-15-1251	Aluminum	12	1
Cylinder Oil Assembly	1040-00-658-5565	D31-15-1240	Aluminum	59	1
Valve Cover	4820-00-622-3400	D31-15-1300	Aluminum	75	1
Shroud	1040-00-659-5166	C31-15-1232	Aluminum	41	1
Cylinder End	1040-00-659-5172	C31-15-1236	Aluminum	19	1
Tool Box Assembly	----	E31-15-1448	Aluminum	1,176	1

NA - Not Available

Source: Arthur D. Little, Inc., based on information provided by LEAD personnel.

Table 6-3  
Smoke Generator Parts

- A) Oil Pump Cover - Aluminum  
 1040-00-659-5174  
 S.A. = 15 in.<sup>2</sup>

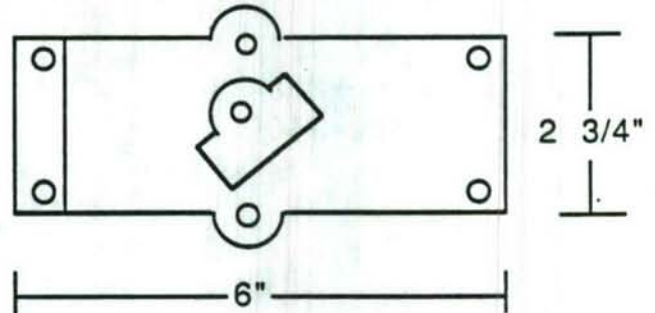

- B) Shroud - Aluminum  
 1040-00-659-5167  
 S.A. = 27 in.<sup>2</sup>

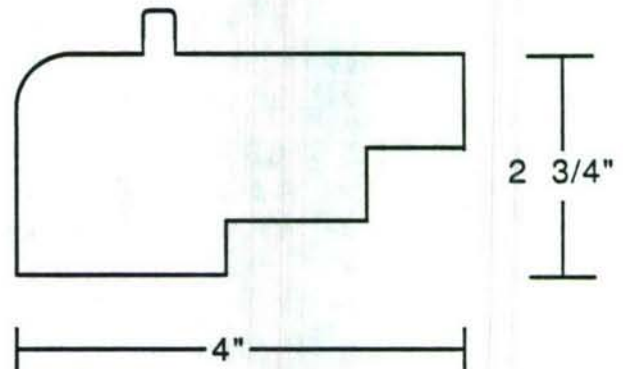

- C) Oil Dis Separator - Aluminum  
 1040-00-659-5180  
 S.A. = 12 in.<sup>2</sup>

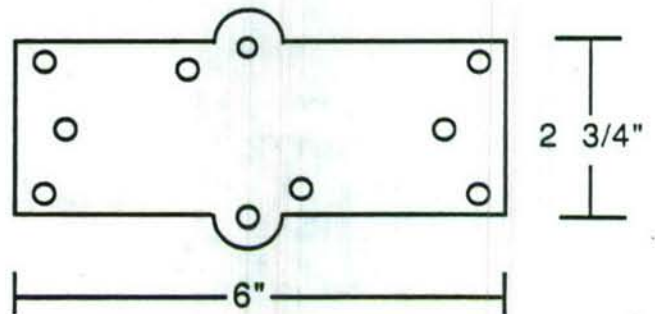

- D) Cylinder Oil Assembly - Aluminum  
 1040-00-658-5565  
 S.A. = 59 in.<sup>2</sup>

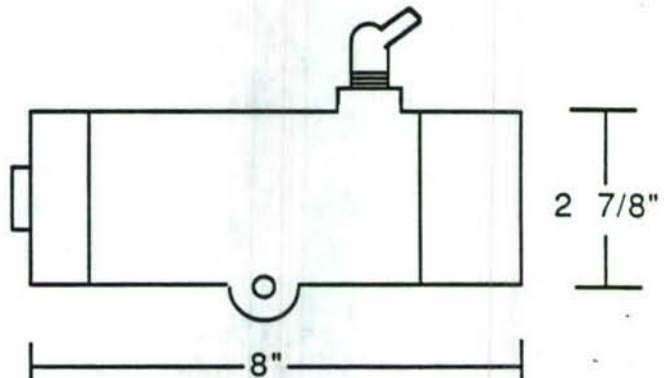
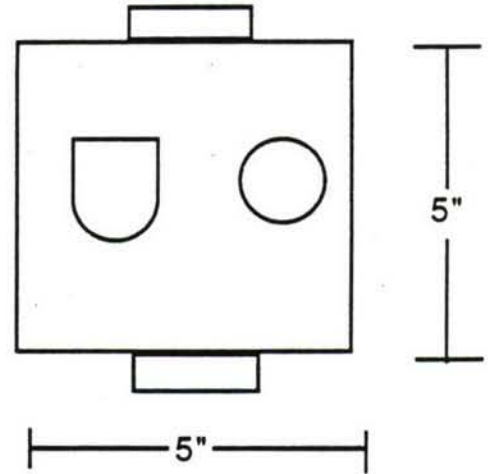
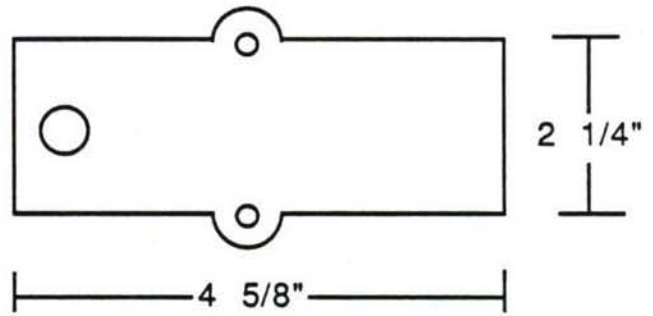

Table 6-3 (continued)  
Smoke Generator Parts

- E) Valve Cover - Aluminum  
 4820-00-622-3400  
 S.A. = 75 in<sup>2</sup>



- F) Shroud - Aluminum  
 1040-00-659-5166  
 S.A. = 41 in<sup>2</sup>



- G) Cylinder End Top  
 1040-00-659-5172

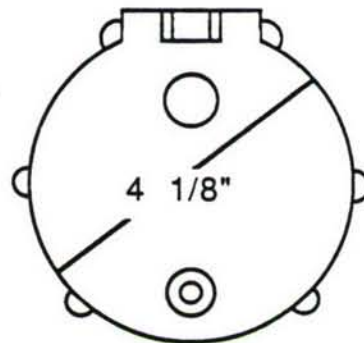

- H) Front Cover

S.A. = Painted Surface Area  
 Source: Arthur D. Little, Inc. and Letterkenny Army Depot

Table 6-4  
8V Engine Parts

- A) Air Box Cover - Aluminum  
 2815-00-159-8753  
 5132458 S.A.= 21 in<sup>2</sup>

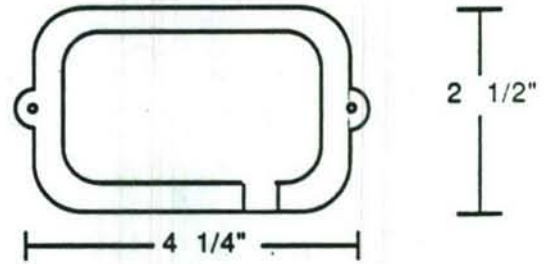

- B) Air Box Cover - Aluminum  
 2815-00-159-8754  
 5144186 S.A.= 40 in<sup>2</sup>

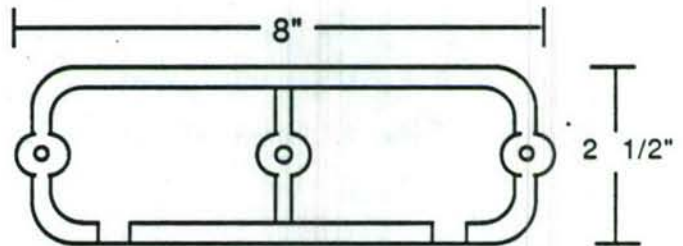

- C) Flywheel Cover - Steel  
 2815-00-902-1767  
 5122219 S.A.= 28 in<sup>2</sup>

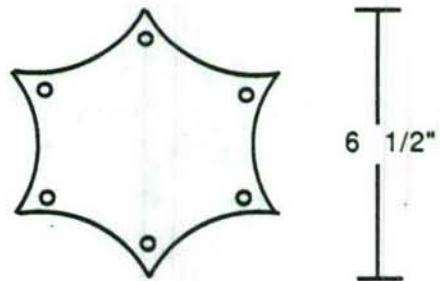

- D) Flywheel Cover - Steel  
 2815-00-986-0489  
 5122281 S.A.= 49 in<sup>2</sup>

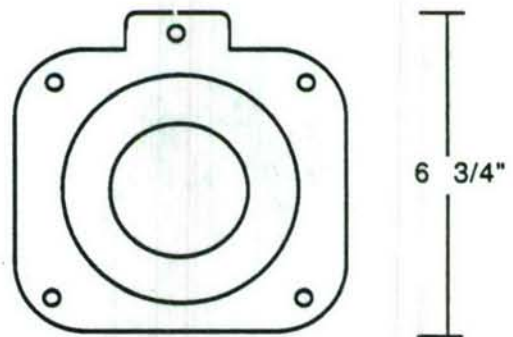

- E) Camshaft Damper - Steel  
 5189863

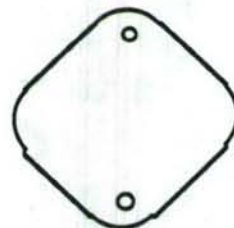
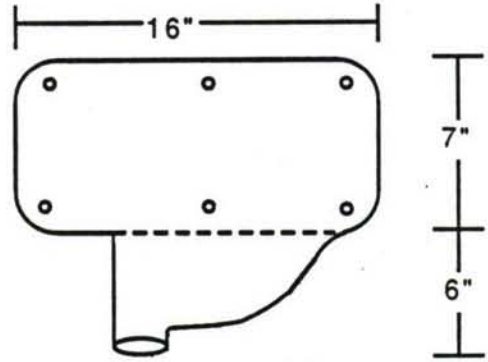
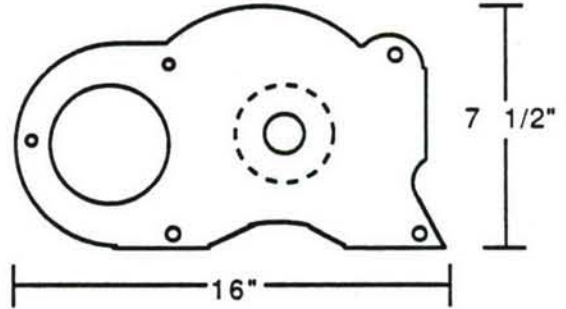

Table 6-4 (continued)  
8V Engine Parts

F) Air Housing - Aluminum  
 5136789 S.A.= 205 in<sup>2</sup>



G) Camshaft Gear Cover - Aluminum  
 5122680 S.A.= 241 in<sup>2</sup>



H) Pulley - Steel  
 3020-00-217-5707  
 5138717 S.A.= 71 in<sup>2</sup>

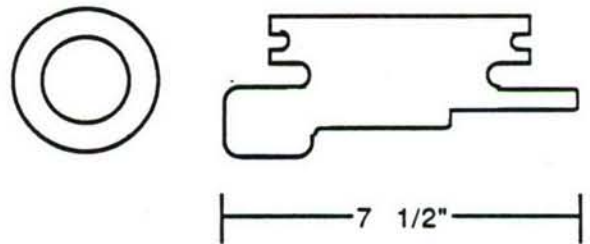

I) Shaft - Steel  
 2815-00-961-9802  
 5117920 S.A.= 20 in<sup>2</sup>

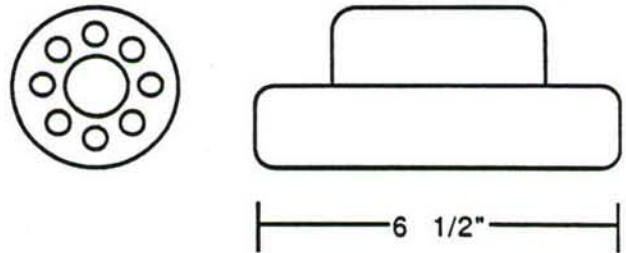

J) Valve Cover - Aluminum  
 2990-00-443-2103  
 5132550 S.A.= 450 in<sup>2</sup>

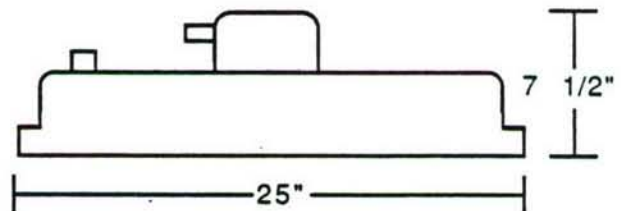
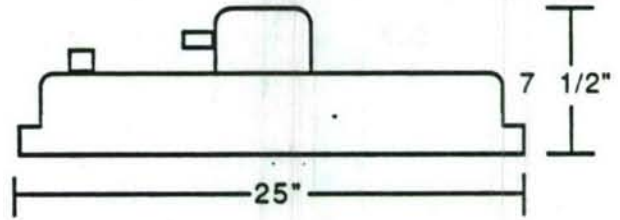
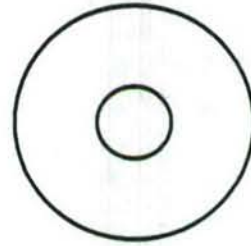

Table 6-4 (continued)  
8v Engine Parts

K) Valve Cover - Aluminum  
5140317 S.A.= 450 in<sup>2</sup>



L) Damper - Steel  
5109863



M) Elbow - Steel

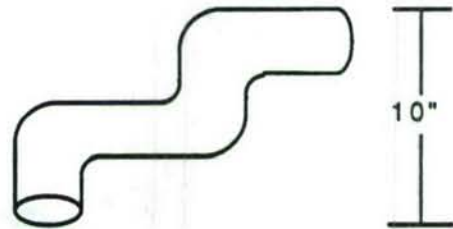

N) Fuel Strainer Shell  
5575893



O) Air Intake  
5103041 S.A.= 495 in<sup>2</sup>

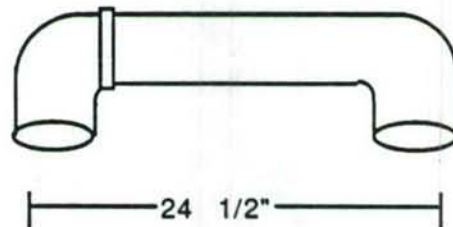
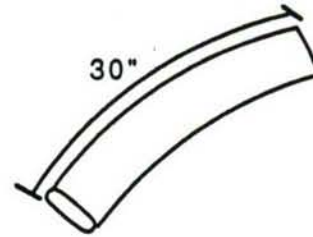
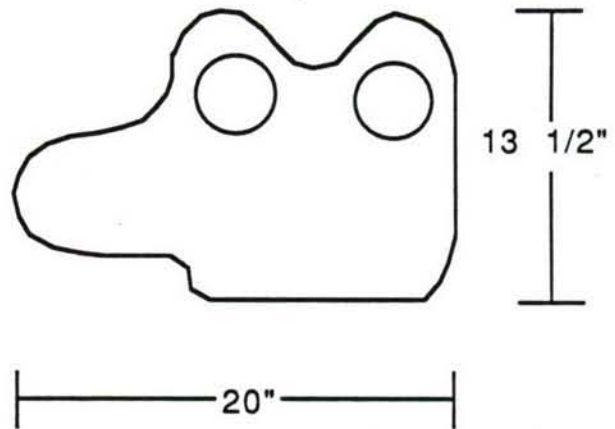

Table 6-4 (continued)  
8V Engine Parts

- P) Cross Over Tube - Steel  
5102826 S.A.= 353 in<sup>2</sup>



- Q)  
Front End Plate - Steel  
2815-00-855-5789  
5132422 S.A.= 244 in<sup>2</sup>



- R) Miscellaneous Small Parts  
Approx. S.A.= 15 in<sup>2</sup>

---

S. A. = Painted Surface Area

Source: Arthur D. Little, Inc. and Letterkenny Army Depot



The items or groups of items to be blasted will be logged on the Parts Log (Table 6-6). For each set of parts (i.e., smoke generator or 8V engine), the paint thickness will be determined using a Minitector 150 thickness gauge (aluminum parts), or an Inspector Thickness Gage (steel parts). See Appendix E for measurement procedures for both these gauges. The condition of the paint will also be noted on the Parts Log.

Prior to beginning the test run, the blasting parameters to be used will be verified between the engineer and blasting operator. This information will be recorded on the Media Log (Table 6-7).

#### 6.1.3.4 Test Runs

Each test run will last for approximately four hours of depainting time. Depainting time will be measured as the time that blasting is actually occurring as measured with a suitable timing device activated by the nozzle switch. Time to load and unload parts into the cabinet is not included.

During each cabinet test run, smoke generator parts will be depainted as sets. 8V engine parts will be depainted separately or in groups of two or three parts, depending on the anticipated depainting time. When depainting is completed, the blasting will stop, and the elapsed time will be recorded on the Parts Log. When the parts are removed from the cabinet, the engineer and operator will conduct a visual inspection of the depainted parts, looking for surface damage, amount of residual paint, and any corrosion on the metal surface. Visual observations will be noted and recorded both on the Parts Log (under comments) and in the Arthur D. Little laboratory notebook. More parts will then be loaded into the cabinet, and blasting will continue.

Over time the feed hopper will be replenished as necessary to make up for the loss of media. The amount and time of media addition will be recorded on the Media Log (Table 6-7).

At the end of the four hours of blasting, the parts currently being depainted will be completed and removed from the cabinet or blast room. The actual total blast time will be recorded, and a final assessment made of the quality and effectiveness of the blasting in that particular test.

Following each run, the cabinet will be blown down and cleaned to get the residual media back into the feed hopper. Once recycling is complete, the residual media will be removed and weighed, and a sample taken for sieve analysis. The dust collector will be shaken to remove as much dust as possible from the filters, and the dust will be removed from the hopper and weighed. All data will be recorded on the Media Log.

Media flow rate tests will be performed as a calibration check on the PMB system. The recycle system will be cut off so that the blasted media will be collected in a separate hopper. A known amount of media will be put into the feed hopper and the total time required to blast (expend) all the media from the feed hopper will be recorded. From this data, one



TABLE 6-7

MEDIA LOG

Day \_\_\_\_\_  
 Date \_\_\_\_\_  
 Run \_\_\_\_\_

Operator \_\_\_\_\_  
 Engineer \_\_\_\_\_

Media

Manufacturer \_\_\_\_\_  
 Grade \_\_\_\_\_  
 Mesh Size \_\_\_\_\_

Blasting Parameters

Air Pressure \_\_\_\_\_ PSI  
 Nozzle Distance \_\_\_\_\_ Inches  
 Nozzle Angle \_\_\_\_\_ Degrees  
 Nozzle Size \_\_\_\_\_ Inches  
 Flow Rate \_\_\_\_\_ lbs/min

Materiel Being Depainted \_\_\_\_\_

Blast Facility Walk-In Booth/Cabinet (circle one)

lbs of Media

<u>Start</u>	<u>Added</u>	<u>Added</u>	<u>Added</u>	<u>End</u>	<u>Waste</u>
( )*	( )*	( )*	( )*	( )*	( )*
_____	_____	_____	_____	_____	_____
_____	_____	_____	_____	_____	_____
_____	_____	_____	_____	_____	_____
_____	_____	_____	_____	_____	_____
_____	_____	_____	_____	_____	_____
_____	_____	_____	_____	_____	_____
_____	_____	_____	_____	_____	_____
_____	_____	_____	_____	_____	_____
_____	_____	_____	_____	_____	_____
_____	_____	_____	_____	_____	_____

Total grams

\_\_\_\_\_ ÷ 454 g/lb  
 \_\_\_\_\_ (a)    \_\_\_\_\_ (b)    \_\_\_\_\_ (c)    \_\_\_\_\_ (d)    \_\_\_\_\_ (e)    \_\_\_\_\_  
 Pounds of media added (a+b+c+d)    \_\_\_\_\_ (f)  
 Pounds of media at end (e)    \_\_\_\_\_ (g)  
 Pounds of media consumed (f-g)    \_\_\_\_\_

\*Time as recorded by nozzle timer

can then calculate the mass flow rate of the media from the blast nozzle at a specified feed hopper valve setting.

Finally, at the end of every test run, comments will be made by the engineer and operator describing the test run on the Media Size Log and Parts Log data sheets. Comments may include such issues as: difficulty in maintaining blast parameters, excessive dust generation, problem with blasting equipment, etc. Engineer and operator comments will also be recorded in an Arthur D. Little laboratory notebook.

In the blast room tests in Series 4, each item of equipment to be blasted will be measured to determine overall surface area and paint thickness. Prior to the start of the run, the media in the hopper will be set at a specific predetermined level. The parameters to be used (air pressure, nozzle angle, flow rate and distance) will be determined based on experience to date in other tests. (To ensure adequate dust removal for visibility and safety, a 100 linear ft/min air flow will be maintained in the blast room.) The time to blast the item will be recorded, and the item will be inspected after blasting for blast quality. After all media has been recycled into the hopper, the amount of media added to restore the predetermined level will be recorded as the amount of media used.

## 6.2 Test Series 1

### 6.2.1 Objective

The objective of Test Series 1 is to determine the variability of test results and any changes needed in test procedures. Test Series 1 will identify how closely test results are duplicated when repeat tests are run under the same conditions. Test Series 2, 3 and 4 do not have repeat runs planned, so the results of Test Series 1 will be used to put approximate confidence limits on the results from the other tests. If the test results show a very large variability, repeat runs may be necessary on subsequent testing. If such repeat tests are deemed necessary, additional time for testing will be required which will ultimately extend the milestone schedule presented in Section 6.10.

### 6.2.2 Test Procedure

Two sets of five repeat test runs will be performed using standardized blasting conditions. Each set will use a different type of plastic media. The media will be selected from the media available at LEAD when Series 1 Tests are started. Once these tests are completed, the data will be evaluated and any modifications (if deemed necessary) to the remainder of the test plan will be made.

## 6.3 Test Series 2

### 6.3.1 Objective

The objective of Test Series 2 is to determine the paint removal rates and the durability of 15 different grades and types of commercially available plastic blasting media. This test series is important because

the number of suppliers and grades of media available commercially has been increasing rapidly as new companies have recognized the potential markets in the field of plastic media blasting. Substantial differences in the quality of media from different vendors and different batches from the same vendor have been reported by those using PMB in production.

In the evaluation of the various media, two key parameters for each type and grade of media will be evaluated: (1) paint removal rate; and (2) media recycle rate. The paint removal rate is important because it indicates the amount of labor (manhours) necessary to remove the paint from a given part, and labor cost is one of the major cost elements in depainting. The durability or recycle rate of the media is also very important in PMB because of the high cost of the media in comparison with other highly abrasive media such as sand, peridot, staurolite, and copper slag grit. If high recycle rates are not achieved with the plastic media, the cost effectiveness of PMB is significantly reduced.

The results of these tests will define the preferred media for use in the remainder of the program.

#### 6.3.2 Media for Testing

The media to be tested are listed in Table 6-8. U.S. Technology Corp. was the original supplier of plastic media. They supply three grades in several mesh sizes. Each grade has a different hardness and is made with a different type of resin. Throughout the PMB industry, U.S. Technology Corp. media is recognized as the basis for comparison for all other media; consequently, this media will be studied most intensively. Three types of media along with two to three different mesh sizes for each will be evaluated.

Aerolyte Systems supplies three grades of media that are similar in hardness to those of U.S. Technology Corp. In order to compare the Aerolyte media with that of U.S. Technology, one grade in one mesh size of the Aerolyte media will be tested.

The Du Pont Company is supplying plastic media in two grades, one based on a thermoplastic acrylic resin, the other on a thermosetting acrylic resin. Because the Du Pont media are the only grades made with acrylic resin, both of these grades will be tested in two different mesh sizes.

Potters Industries supplies one grade of plastic media in four different mesh sizes. One grade in one mesh size of the Potters Industries product will be tested.

MPC is a small supplier that also supplies three different grades of media with hardness comparable to those of the U.S. Technology Corp. For purposes of obtaining initial comparison, one grade of MPC media in one mesh size will be evaluated.

TABLE 6-8

PLASTIC BLAST MEDIA TO BE TESTED

<u>Supplier</u>	<u>Number of Grades</u>	<u>Number of Mesh Sizes (per Grade)</u>
U.S. Technology Corp.	3	3
Aerolyte Systems	1	1
Du Pont Co.	2	2
Potters Industries	1	1
MPC Industries	1	1

Source: Arthur D. Little, Inc.

### 6.3.3 Test Procedure

Four hour tests will be run as described in the test matrix (Table 6-1). Standard blasting parameters will be used. In addition to the 15 plastic media that will be tested, glass beads and walnut shells will also be tested for comparison. For glass beads and walnut shells, the blast pressure will be 90 psi, which is the pressure normally used at LEAD for blasting with these media.

### 6.4 Test Series 3

#### 6.4.1 Objective

The objective of this third test series is two-fold; first, to evaluate the effects of blasting parameters on paint removal rate and media attrition; and second, to evaluate the differences in removal rate with conventional paint coatings versus CARC paint systems.

#### 6.4.2 Test Procedure

Tests Series 3 will be run using the two top-rated media as determined in Test Series 2. For each type of media, tests will be run changing one of the standard blast parameters at a time. The standard parameters are: 3 lb/min media flow rate, 10 inch blasting distance, and 30 psi blast pressure. The alternate parameters to be tested are: 6 and 9 lb/min media flow rate, 4 and 16 inch blasting distances, and 50 psi blast pressure. Test runs will then be also carried out using the standard blast parameters and parts painted with CARC systems.

### 6.5 Test Series 4

#### 6.5.1 Objective

The objective of this test series is to determine the effectiveness of PMB for depainting different types of U.S. Army materiel in comparison with the depainting methods currently used.

#### 6.5.2 Test Procedure

Larger sized items will be tested in the blast room. Groups of parts representing different types of materiel such as shelters and containers will be depainted with PMB, and the time recorded. The media usage will be approximated by the amount of media required to restore the level of media in the feed hopper after each part or group of parts is blasted. In these tests, we will also attempt to test blast materiel with different materials of construction, e.g., thin and heavy aluminum, heavy steel, etc.

### 6.6 Assistance Needed from Depots

There are several areas in which assistance will be needed from the depots in connection with this program. As was previously indicated, the proposed location for the work is Letterkenny Army Depot, but support may

be needed from other depots in obtaining appropriate materiel for testing and also for obtaining data on the economics of current depainting methods for each type of materiel. Specific areas in which assistance will be required include the following:

- Use of available blast facilities as appropriate;
- Space to set up equipment and store test materiel;
- Personnel to install/hook up equipment and move equipment and materiel;
- Necessary utilities (air and electricity);
- Blasting personnel full time for 4 to 5 months;
- Acquisition of suitable quantities of specific parts, types of materiel, etc. for depainting tests; and
- Detailed accurate data on costs of current depainting (abrasive blasting, chemical stripping, etc.) operations for each part/type of materiel.

#### 6.7 Automated Equipment for Small Parts Blasting

The cleaning of small parts for many types of equipment is a particular concern at many of the depots. Much of the small parts cleaning is now done in dip tanks with a methylene chloride-based stripper. The dip tank method is very efficient from the standpoint of both labor and material (chemical) costs. Therefore, direct replacement with plastic media blasting is not likely to prove economical unless a highly automated facility for handling the small parts can be utilized. Even then, the capital cost of the automated equipment and the high cost of the media may prevent small parts blasting from being economically competitive with dip tank stripping, given current methods and costs of hazardous waste disposal and current OSHA regulations.

Nevertheless, it is important that plastic media blasting be evaluated as an alternative to dip tank stripping because it is possible that severe additional restraints on the use of methylene chloride strippers may come into effect in the future to reduce worker exposure and hazardous waste disposal costs. Presently, worker exposure to methylene chloride is coming under close scrutiny because of the potential carcinogen status of methylene chloride. If any additional evidence surfaces regarding adverse health effects of methylene chloride exposure, future regulations could require the extensive use of enclosures and improved ventilation to limit worker exposure to methylene chloride vapors. These measures could entail considerable capital investment and reduced workplace efficiency. Furthermore, if any new evidence confirms the carcinogenic nature of methylene chloride, its use might be banned or severely restricted.

In addition, the use of these chemical dip tanks generates significant amounts of hazardous waste in the form of: (1) paint sludge containing heavy metals and methylene chloride; (2) rinse water contaminated with methylene chloride; and (3) spent stripper from the tanks when they are periodically emptied and refilled. Increasing costs for hazardous waste disposal and new treatment facilities to handle the contaminated wastewater could reduce the economic advantages of chemical dip tank stripping over PMB depainting.

Given this situation, it is possible in the future that PMB might become a cost-effective alternative for small parts cleaning.

The original proposal for the PMB test plan included the shipment of small parts to a vendor's plant for evaluation of automated equipment for depainting actual U.S. Army materiel. However, it now appears that problems in both production scheduling and accountability for the parts will prevent shipments of parts off the depot. This change does not present a major problem for the test plan. As an alternative, visits will be made to the plants of vendors who are working on automated equipment for small parts blasting to inspect the equipment and observe it in use. The data obtained during these visits will then be used to evaluate the potential for use of the automated equipment in depots for small parts depainting. Initial agreement has been reached with one vendor, and we expect to make arrangements with one or two additional vendors to evaluate their automated equipment.

In addition to the PMB evaluation, as an alternative for small parts depainting, specific inquiries will be made and data gathered on the potential use of high-temperature salt baths and hot air soaks with and without subsequent brush blast for small parts cleaning. Some data that has already been gathered on the thermal processing indicates that it will be a suitable alternative for at least some types of small parts. All of the data will be summarized in the final report and will represent a significant addition to the initial data base on depainting which is the goal of this program.

#### 6.8 Updating of PMB Developments

An important part of the work during the testing to take place at LEAD will be to maintain contact with military and commercial organizations regarding new developments in the field of PMB. There are a number of new PMB facilities currently being installed at U.S. Army, Navy and Air Force bases and depots. Some of these new blast facilities are designed specifically for ground support equipment, and experience with them should therefore be applicable to various types of U.S. Army materiel. In addition, the exchange of information between military services using PMB is extremely important in providing maximum benefit to all parties involved by preventing duplication of efforts.

Another important aspect of the continuing data gathering effort during the test program is liaison with commercial users of PMB and commercial suppliers of both plastic media and blasting equipment. For instance, contact has already been made with the U.S. subsidiary of a German

company that is currently developing PMB roto blasting equipment that can be used in place of pneumatic blasting. The roto blast equipment is similar to that used for steel shot and steel grit blasting in automated machines and uses centrifugal acceleration of the blasting media in place of compressed air. It is, therefore, much more energy-efficient.

It is extremely important that such new developments be sought out to continually update the data base on PMB, particularly in this period of rapid new developments. A continuing search of literature and commercial contacts will be maintained during the course of the test program to assure that the final report on this program provides the appropriate up-to-date data on the state of the art in PMB.

#### 6.9 Reporting

The Draft Final Report will be submitted to USATHAMA approximately eight weeks after the completion of the pilot testing. The report will include a description of the pilot test equipment, preliminary evaluations utilized in selecting the conditions for the test, operating experience, pertinent data collected during the tests, data reduction procedures, and an interpretation and discussion of the test results. In addition, any data or information obtained from continuing contact with U.S. Navy and Air Force personnel involved with PMB, and/or commercial suppliers of both plastic media and blasting equipment, will be summarized in the Final Report. Following USATHAMA review (approximately two weeks), we will make any necessary corrections or revisions (within three weeks) and forward a Final Report to USATHAMA.

#### 6.10 Schedule

A milestone schedule along with the proposed completion dates is provided in Table 6-9.

TABLE 6-9

MILESTONE SCHEDULE

<u>Milestone</u>	<u>Proposed Completion Date (1987/1988)</u>
Place order for PMB room	November 20
Modify cabinet as necessary to handle plastic media	December 4
Vendor visit to LEAD to examine location for new PMB room	December 10
Acquire media (plastic, glass & walnut) for data duplication and paint removal/durability tests in cabinet	December 11
Begin data duplication tests	December 11
Complete data duplication tests	January 15
Begin paint removal/media durability tests	January 25
Begin site preparation for new PMB room	January 29
Complete paint removal/media durability tests	March 4
Complete evaluation of data from data duplication and paint removal/media durability tests	March 11
Acquire media for parameter optimization and materiel variation tests	March 14
Begin parameter optimization tests in cabinet	March 14
Complete site preparation for PMB room	March 14
Begin installation of PMB room	March 25
Complete parameter optimization tests in cabinet	April 8
Complete installation of PMB room	April 14
Complete evaluation of data from parameter optimization tests and select optimum parameters for materiel variation tests	April 15
Begin materiel variation tests	April 18
Complete materiel variation tests	June 13
Submit Draft Final Report to USATHAMA	July 11
USATHAMA review of Draft Final Report	July 25
Submit Final Report to USATHAMA	August 11

## 7.0 REFERENCES

1. 29 CFR Chapter XVII, Subpart G, Section 1910.94.a(2)iii.
2. NIOSH Current Intelligence Bulletin No. 46, April 19, 1986.
3. "Plastic Media Blasting Data Gathering Study," Final Report CR 87.006, Naval Civil Engineering Laboratory, Port Hueneme, CA, December 1986.
4. "Paint Stripping of F-4 Aircraft and Component Parts using Mechanical Method PRAM," Project 00-143, Final Report, Aircraft Division, Directorate of Maintenance, Ogden Air Logistics Center, Hill Air Force Base, UT, 28 August 1986.
5. "Economic Analyses for Recycling Plastic Media," Final Report CR 87.001, Naval Civil Engineering Laboratory, Fort Hueneme, CA, February 1987.
6. "Stripped Clean and Dry," Karl Forth Aviation Equipment Maintenance, p. 28ff, October 1985.
7. "State of Plastic Media Blasting," Robert Pauli, SAE Technical Paper 860701, February 1986.
8. "Dry Stripping Cuts Hazardous Waste Materials," Aviation Week and Space Technology, p. 83ff, March 3, 1986.
9. "Aircraft Repainting: Color It Confusing; and Blast Those Beads," The Aviation Consumer, Vol XVI, No. 23/24, December 1986.
10. "Stripping with Plastic Media", Ted Tassone, Industrial Finishing, p. 14ff, February 1987.
11. "Plastic Bead Blast Materials Characterization Study," Battelle Columbus Division, Final Engineering Report, July 1986.
12. "Plastic Media Blasting: Summary of Current Activities," Vol 1, Accurex Corp. EPA Contract No. 68-02-3993, WA-12, January 1986.
13. "Flashblast - The Light that Cleans," Tom Johnson, Popular Science, p. 82ff, July 1982.
14. "Flashlamp Depainting System," Final Report, USAF PRAM Program, Project 82-5, Sacramento Air Logistics Center, McClellan Air Force Base, CA, July 1986.

APPENDIX A

DEPOT TELEPHONE/SITE VISIT SUMMARIES

TABLE OF CONTENTS

	<u>Page</u>
• Anniston	A-1
• Corpus Christi	A-5
• Letterkenny	A-14
• Lexington/Blue Grass	A-17
• Red River	A-19
• Sacramento	A-24
• Tobyhanna	A-28
• Tooele	A-31

MEMORANDUM

To: Armand Balasco

Case 54149-05 Date: 3/2/87

Page 1

Subject: Trip Report - Anniston Army Depot

CONTACT

Our primary contact at Anniston was Sue Svec, Health Physicist and Industrial Hygiene Officer, who is in the Safety Office. Her telephone number is 205-235-7541. We also met Tony Pollard (6265), who is a production engineer at Anniston. Sue is very knowledgeable about the overall operations at Anniston and proved to be extremely helpful during our visit, which was on November 20, 1986.

MISSION

The Anniston Depot has a primary mission of overhauling tanks. They have extensive facilities for completely disassembling the tanks and overhauling all parts ranging from the armament to the controls systems to the primary structure and the drive train including the engines, the transmissions, and even the tracks. Because Milvans are used for shipping many parts, they also become involved in repainting Milvans at the rate of approximately 60 per month inside and out.

Anniston also has facilities in a secondary mission of rebuilding small arms.

DEPAINTING PROCEDURES

A significant part of the depainting at Anniston is large tank hulls, Milvans, and other large parts. Historically, these have been done with sand blasting. However, because of the OSHA concerns about respirable silica, they have more recently started to use a new peridot abrasive trade named "Green Lightening." Some parts are also blasted with Black Beauty copper slag grit. However, this leaves a residue which kills the action of phosphatizing baths. Therefore, its use is restricted to certain parts. For parts that require a softer blast medium, they utilize walnut shells. For smaller parts, dip tank paint removal and cleaning is utilized. There are also many glove box-type cleaning units throughout the facility.

They found that since the CARC paint systems have been utilized, the paint removal time has increased by about one-third.

The cleaning and depainting of small arms parts is done primarily in degrease tanks and in glove boxes with the peridot, glass bead, or walnut shell abrasives.

Richard S. Lindstrom/ler

15W/222

2156

From.....

Bldg./Room.....Ext.....

MEMORANDUM

To: Armand Balasco

Case 54149-05 Date: 3/2/87

Page 2

Subject: Trip Report - Anniston Army Depot

In the dip tank depainting operations, they use phenolic strippers which are being replaced with methylene chloride/formic acid strippers. Centrifugal separators are being evaluated to remove the paint sludge from the paint stripper tanks.

There is also some reworking of ammunition at Anniston. The depainting and repainting here involves primarily hand-sanding in a controlled fashion. No blasting is used.

For the cleaning of steel parts where coarse blasting is allowed, Wheelabrator shot blast machines are used. There are a number of these throughout the depot. Their primary facilities include nine walk-in booths, three for tanks hulls which utilize primarily copper slag, two with walnut shells, three with peridot media, and one which still utilizes silica sand.

The abrasive use at Anniston is approximately as follows:

Sand

200 bags/mo. (100-lb. bags)

Slag

130 tons/mo. + 230 bags/mo. (100-lb. bags.)

Green Lightening

1,300 bags/mo. (100-lb. bags.)

Steel Shot

Size 70 1/2 to 1 ton/mo.

Size 330 100 bags/mo. (100-lb. bags)

Size 125 15 bags/mo. (100-lb. bags)

Walnut shells 300 bags/mo. (50 lbs./bag)

Glass Beads

Size 7 200 bags/mo. (50 lbs./bag)

Size 8 200 bags/mo. (50 lbs./bag)

Richard S. Lindstrom/ler

15W/222

2156

From.....

Bldg./Room.....Ext.....

MEMORANDUM

To: Armand Balasco

Case 54149-05 Date: 3/2/87

Page 3

Subject: Trip Report - Anniston Army Depot

Cost

Green Lightening \$0.03-0.05/lb.  
Slag \$0.02-0.2.5/lb.  
Sand \$0.02/lb.  
Walnut shells \$0.20/lb.  
Glass beads \$0.31-0.35/lb.  
Plastic media \$1.79/lb.

Garnet, which is \$0.40 per pound has also been looked at as an alternative to sand, but the cost proved to be excessive compared with peridot-based media.

They have also been evaluating the use of 800°F salt bath for depainting some of the steel parts. The equipment is made by the Kolene Company in Memphis.

Anniston on occasion does some electronic shelters. They claim that it is faster and more economical to strip out all wiring so that the entire shelter can be blasted with highly abrasive media rather than leaving the wiring in as is done at some other depots.

USE OF PMB

Anniston has run tests with U.S. Technology Polyplus and Polyextra plastic media. They obtained sufficient plastic media to use it in one of their walnut shell walk-in booths. The walnut shell booth was totally cleaned before the plastic media was installed. Several tests were made over a period of time with adjustments being made after each test to adjust the exhaust ventilation system. However, they found that they were not able to achieve any recycling of the plastic media. It all went directly into the dust collection system. They found that the cutting efficiency of the PMB was about the same as that of the walnut shells.

Some additional tests were also run in glove boxes. Although some recycling was obtained, they found that the plastic media degraded very rapidly and had a very low paint removal rate compared with the glass beads normally used in those glove boxes. A copy of a memo prepared by Sue Svec summarizing the situation with regard to plastic media is included as an attachment to this memo.

Richard S. Lindstrom/ler

15W/222

2156

From.....

Bldg./Room.....Ext.....

MEMORANDUM

To: Armand Balasco

Case 54149-05 Date: 3/2/87

Page 4

Subject: Trip Report - Anniston Army Depot

HAZARDOUS WASTE HANDLING

The blasting waste from all the various media blasting operations has been tested for EPA toxic leachables. They have found that these are sufficiently low in concentration that the spent media can be land filled so the disposal costs are minimal. They are concerned that any new media that might be used and recycled would tend to concentrate the waste and increase the leachables content to the point where it would then be considered a hazardous waste, and significant disposal problems would be introduced which are not now present. Because they do not have toxic waste to dispose of at the present time, they do not have any costs for disposal of spent toxic media and paint dust. Additional information should be obtained on actual current methods of disposal and costs of disposing of waste from the chemical cleaning tanks in follow-up contacts with Anniston.

WORK LOAD

The primary work load at Anniston is an average of three M60 tanks per day and two 551 tanks. They also do various Milvans and containers. They may be up to four Milvans and as many as 35-40 small containers per day.

OTHER DEPAINTING METHODS

Anniston is satisfied with the current depainting methods that are being used and have not investigated to any significant extent any of the additional new paint removal techniques that are being explored by other depots and services, except for the hot salt baths and hot air which they feel have some potential for some operations to replace tank stripping and/or abrasive blasting.

Richard S. Lindstrom/ler

15W/222

2156

From.....

Bldg./Room.....Ext.....

MEMORANDUM

To: Armand Balasco

Case 54149-03

Date 01/08/87

Page 1

Subject: Trip Report Corpus Christi Army Depot

CONTACTS

Our primary contacts at Corpus Christi were John Bullington, Chemist - Aerospace Materials and Processes (512-939-3555); and Randy Williams, Industrial Engineer (512-939-3243/3979/2214). These two individuals have clearly put a lot of time, effort, and study into the question of depainting procedures and PMB in particular. They were extremely helpful and knowledgeable.

MISSION

Corpus Christi is exclusively concerned with repair and overhaul of rotary wing aircraft (helicopters). In addition to the helicopters and parts, some depainting work is done on shipping containers used for helicopter engines and transmissions.

DEPAINTING PROCEDURES

Prior to 1978, Corpus Christi utilized a phenol cresol-based paint stripper for the entire air frame using spray application and water rinse. In 1978, the phenolic stripper was banned, and they went to a formic acid/methylene chloride stripper. This type of stripper is also used in the dip tanks for depainting small air frame components and engine and transmission components. In addition, they have glove boxes in which they use steel shot, glass beads, walnut shells, vapor honing, and some sand blasting. They also have several large centrifugal steel shot blasting machines.

Walnut shell blasting was evaluated for the air frames but was found to be too aggressive on the thin metal used on many parts of the air frame. It is also very dusty and was considered hazardous from that standpoint.

The materials that are being stripped range from 2024 alclad aluminum sheet to titanium sheet, epoxy fiberglass, and epoxy Kevlar along with some boron and graphite-based composites. Portions of the air frame include steel tubing and steel flanges. There is also an air duct in some of the helicopters that is made of polycarbonate. The primary paint that has been used on the air frames in the past was an acrylic topcoat over an epoxy primer. As of January, 1986, they switched over almost entirely to a CARC polyurethane formulation which is difficult to remove with the current chemical strippers. In those few cases where CARC coatings have been removed by chemical stripping, this task requires about three times the amount of the stripping chemical that is required for the acrylic epoxy system.

Richard S. Lindstrom/ler

15W/222

2156

From.....

Bldg./Room.....Ext.....

MEMORANDUM

To: Armand Balasco

Case 54149-03

Date 01/08/87

Page 2

Subject: Trip Report Corpus Christi Army Depot

Because of the durability and resistance to depainting of the CARC formulations, it has been proposed by some depot and field personnel that complete stripping and repainting is no longer needed at every overhaul. On the other hand, there are strong indications that many field commanders would not accept an aircraft as fully overhauled if it were not totally repainted. In addition to the CARC on the air frame, a phenolic epoxy paint is now being used on the gear boxes of the helicopters. This is even more resistant to stripping than the CARC, and it cannot be removed by walnut shell blasting alone. The only available procedure currently is to soften the paint in the stripping bath, and then blast it to remove the paint with either walnut shells or plastic media.

Historically, the containers were prepared for repainting by hand grinding and sanding which was a very laborious process. At the present time, Corpus Christi is installing a blast facility which is scheduled to be ready next July in which they will use DuPont's Starblast or other aggressive non-silica media for paint removal on shipping containers. The media will be recycled in this facility.

USE OF PMB

Because of the intense pressure to move away from first the phenolic stripper and now even from the methylene chloride stripper, Corpus Christi has developed a keen interest in plastic media blasting. They did a number of small scale evaluations in glove boxes, and then in 1984, obtained some old Clemco blast equipment, modified it, created a blasting area within an existing building, and ran PMB trials on OH58 air frames. They did 28 air frames to develop the necessary data to justify a new facility. On these air frames, they depainted only the fiberglass epoxy skin which is about 40 percent of the area of the air frame. The aluminum skin was chemical stripped because there was inadequate data on effects of PMB on aluminum. While awaiting the construction of the new blasting facility, they lost the old facility to another unit so they have no PMB capability at the present time except in glove boxes of which there are approximately 12 to 15 at the depot. They are constructing a new temporary facility which will be ready about the first of the year.

The new permanent facility will be approximately 30 feet by 60 feet by 30 feet high and is being constructed by Maltby Tank and Barge Inc. Systems Division of Everett, Washington. The supplier of the actual blasting equipment has not yet been determined. The cost of the total facility will be over \$800,000. The electricals will be dust explosion proof. It is scheduled to be completed in the summer of 1987. The media used will

Richard S. Lindstrom/ler

15W/222

2156

From.....

Bldg./Room.....Ext.....

MEMORANDUM

To: Armand Balasco

Cas 54149-03

Date 01/08/87

Page 3

Subject: Trip Report Corpus  
Christi Army Depot

probably be Polyplus, but the facility is designed to allow change of media in two hours.

The plastic media used in the prototype work on the OH58 was supplied by U.S. Technology (Type III). They plan on the media being recycled at least eight times. However, they have some indications that even the U.S. Technology media, that is currently being supplied, does not stand up as well as that which they evaluated originally. They have not worked with media from Aerolyte or other suppliers, but they understand that the media from other suppliers is not as durable as that from U.S. Technology. DuPont has been active in sampling plastic media and appear to have a serious interest in entering this market. John Bullington expressed concern that if PMB becomes widely used very quickly, there may be inadequate production capacity and/or media quality may suffer.

John Bullington indicated that as a result of their extensive experience at Corpus Christi they have some ideas on special media that would be more useful in removing sealants and other tough materials.

The durability of the media is dependent on the operator's skill and training as is the quality of the work. In addition, it is important that the equipment be properly designed to handle plastic media. For instance, a valve designed by NASA can be used to provide more consistent media concentration in the blasting stream. Schmidt Manufacturing is currently using this type of valve on their commercial equipment.

It is likely that different types of parts will require different hardnesses and sieve sizes of media to provide optimum cleaning speed. In general, in their trial work, they found that the man hours required for paint removal were reduced by at least 60 percent using plastic media as compared with chemical stripping.

On the OH58 the paint can be removed from the epoxy fiberglass with the plastic media with proper control. However, this is not necessarily true for all epoxy fiberglass laminates. The OH58 is a Bell product, and the Bell laminates tend to have a high resin content and resin-rich surface which minimizes any fiber degradation during blasting.

Much of the aluminum skin on the helicopters is in the range of .040 inches, and some as thin as .008 inches. As a result, there is concern about the effects of blasting on the aluminum.

Richard S. Lindstrom/ler

15W/222

2156

From.....

Bldg./Room.....Ext.....

MEMORANDUM

To: Armand Balasco

Case 54149-03

Date 01/08/87

Page 4

Subject: Trip Report Corpus  
Christi Army Depot

Both John Bullington and Randy Williams emphasized repeatedly that the effectiveness of plastic media blasting depends on the operator's skill and that there are sometimes people and training problems.

They noted that on commercial aircraft, such as the DC9s that Republic is depainting with PMB, the skins run from .063 inches up, and Republic uses pressures up to 50 psi for blasting. For helicopters, they found at Corpus Christi that pressures in the range of 35 psi in glove boxes and 25 psi on air frames can be used effectively and must be maintained to avoid damage. One of their concerns is that if higher pressures are used, there may be sufficient movement of the surface metal to close up cracks so that they are more difficult to detect during inspection following the depainting operation.

When their large facility is completed, air frames and possibly rotor blades will be done in that. Engine and transmission parts will still be processed through dip tanks for paint stripping. In cases where the phenolic epoxy paint is used, subsequent blasting is likely to be necessary to fully strip the parts. With the new facility they anticipate that 90 percent of the large scale (non-dip tank) chemical stripping will be eliminated.

In working with various substrates, they have found that Kevlar laminates are particularly difficult to strip whether it be chemical stripping or plastic media blasting. It appears that the Kevlar laminates are made with a minimum of resin matrix. As a result, the fiber acts as a dry laminate, and fibers are easily raised during the blasting operation. Again, it is possible that with the proper control and blast resistant primers, these composites can be depainted with PMB.

At one point in the development program, the Coast Guard from Elizabeth City, North Carolina, brought some polyester fiberglass parts to Corpus Christi to be blasted on a trial basis. The plastic media eroded the surface of that composite. However, again the proper selection of media hardness, size, blast pressure, and other parameters may allow blasting of polyester fiberglass parts as more experienced is gained and personnel become better trained, and effective blast resistant primers are developed.

Because Corpus Christi switched to CARC type paints only in January of 1986, they have had very little occasion to remove CARC thus far since the helicopters are recycled through the depot only every 5 to 10 years. Some early tests indicated that the CARC would be much more difficult to strip with PMB and that the removal rate would only be 1 to 2 square feet

Richard S. Lindstrom/ler

15W/222

2156

From.....

Bldg./Room.....Ext.....

MEMORANDUM

To: Armand Balasco

Case# 4149-03

Date 01/08/87

Page 5

Subject: Trip Report Corpus  
Christi Army Depot

per minute as compared to 10 to 12 square feet with the previous paints. Additional experience is improving these rates with the CARC significantly, but it is likely that removal of CARC will still require two to three times the blasting time needed for the previous acrylic epoxy system. However, since the CARC is also very difficult to strip with current chemical strippers alternative depainting methods are limited.

With regard to the problem of adverse effects on the skin during the blasting process, Bullington noted that the work at Battelle was done on unsupported skins, whereas the thin skins on the helicopters are usually used on honeycomb or with many stiffeners so that they are adequately supported. In addition, for very thin skins, the use of a vacuum blasting head in which the vacuum provides support around the area where the blasting is occurring may help to prevent distortion. They are, therefore, awaiting results of the follow-on work that is now underway at Battelle. They did run some in-house tests to determine whether the aluminum cladding was removed from an alclad sheet. The indications were that although some aluminum was removed and moved around, the aluminum cladding remained intact. They noted that they do not nondestructively test the air frames of the helicopters to the same degree to which such testing is done with fixed wing aircraft.

Rotors are currently primarily aluminum skins but are going to composites. Rotors are not blasted at CCAD at the present time. With proper media and control and training, blasting may be used to repaint the composite rotors in the future.

With regard to dust from plastic media blasting, they noted that OSHA Regulation 1910 applies to organic media but in the past this has meant agricultural media which generated substantial amounts of dust. A new OSHA regulation is needed to cover the synthetic media blasting which generates much less dust.

They are concerned about reports of foreign matter causing damage to the aluminum sheet based on studies by the AF Corrosion Office at Warner Robins which is sponsoring the Battelle work. They indicated that someone has patented a separator which will remove sand from the recycled media and that magnetic separators can be used to remove any ferrous metal particles during recycling of media.

The establishment of a central PMB office has been proposed, but this has not been done yet because of questions of funding availability. To be effective, the office should have adequate funding and a staff of several people.

Richard S. Lindstrom/ler

15W/222

2156

From.....

Bldg./Room.....Ext.....

MEMORANDUM

To: Armand Balasco

Case 54149-03

Date 1/08/87

Page 6

Subject: Trip Report Corpus  
Christi Army Depot

Bullington and Williams note the need for a controlled environment for the blasting in order to assure that it is done properly. The facility they are building will have a controlled environment and is designed with laminar air flow so that dust levels will be far below any hazard level in the operating area of the building.

HAZARDOUS WASTE HANDLING

The Corpus Christi Army Depot is located on the Corpus Christi Naval Air Station in close proximity to the Padre Island National Seashore. For this reason toxic emissions in waste water are very tightly controlled. They have a current limit of 3.3 pounds of total toxic organics per day, and they expect this to drop to less than 1 pound when their permit comes up for renewal in two or three years. We discussed the toxic waste situation with Captain Newman and her assistant, Gloria Delasantos, (Telephone No. 512-939-2072). They noted that the methylene chloride stripper is undesirable because the methylene chloride is both toxic and a potential carcinogen. Therefore, its use in the work place and presence in waste water is highly undesirable. Originally, the methylene chloride stripper used was Mil Spec 25107, which is supplied through the GSA. However, this stripper has some chromate content. Because this was unacceptable, Corpus Christi now uses a stripper without chromate based on a local procurement specification. They noted that because of the number of materials handled, the GSA sometimes tends to be behind the times on environmental issues with regard to the materials that they supply. We are currently awaiting receipt of information being assembled by Capt. Newman on quantities and costs of disposal of hazardous wastes from the depainting operations.

Many of these problems they hope will be solved through the extensive use of plastic media blasting as soon as their facility is ready. They believe there will be a 75 percent reduction in the amount of waste and because of the reduced chromate and cadmium content in the dust, it may be possible to delist it. Tyndall AFB is looking at ways to separate the heavy metals from the waste. CCAD is using an Air Force Universal primer which has relatively low toxic content and low solvent content. The drums of plastic dust are, at the present time, going to a landfill.

One of the concerns is that new coating systems may entirely change the needs and requirements for depainting and also the toxicity situation. For instance, the introduction of new low infrared emission coatings beyond those currently used and stealth technology for radar echo suppression may further complicate the depainting process.

Richard S. Lindstrom/ler

15W/222

2156

From.....

Bldg./Room.....Ext.....

MEMORANDUM

To: Armand Balasco

Case 4149-03 Date 01/08/87

Page:7

Subject: Trip Report Corpus Christi Army Depot

WORK LOAD

The Corpus Christi depot processes about 400 aircraft per year out a total of about 7,000 in the fleet. The projected work load for Corpus Christi for 1987 is as follows:

<u>Aircraft</u>	<u>Number of Aircraft</u>	<u>Man Hours to Strip Air Frame</u>	<u>Square Feet Per Air Frame</u>
Huey UH	216	77.5	--
Huey N	55	88.5	--
Cobra	55	66.5	--
OH-58	59	44.0	Appx. 500
CH-47*	-	-	1825
Blackhawk*	-	-	752

\*New assignment for CC.

In some cases these aircraft are in for total overhaul, in other cases for IRAN (inspect and repair as necessary) or repair of specific damage that requires depot level maintenance. In some of these cases, stripping of the assembled aircraft is desired. This is much more easily accomplished with PMB than with the chemical stripping which would attack gaskets, seals, sealants, and other important components. As noted previously, the man hours to strip the air frame represent about a 60 percent savings over chemical stripping. On average, this is significant in that the labor rate with burden is in the 30 to 35 dollar per hour range at Corpus Christi. Reports generated by CCAD on their work with PMB are on request.

OTHER DEPAINTING METHODS

Corpus Christi has been following the development work in other depots and other services on laser, xenon lamp, and CO<sub>2</sub> pellet blasting but have not pursued any of these themselves. Their information indicates that laser depainting methods are being evaluated by Grumman for the Air Force as well as by Wright Field. The xenon flash lamp work is primarily focussed at McClellan Air Force Base. The information that they have gathered on CO<sub>2</sub> pellet blasting indicates that there are a number of limitations due to mechanical problems with the system and possibility of adverse effects due to the low temperatures generated on the metal surfaces.

Richard S. Lindstrom/ler

15W/222

2156

From.....

Bldg./Room.....Ext.....

MEMORANDUM

To: Armand Balasco

Case 54149-03

Date 01/08/87

Page 8

Subject: Trip Report Corpus  
Christi Army Depot

OTHER CONTACTS

Randy Williams and John Bullington provided a number of useful contacts. One is Randy Ivey at the Air Force Corrosion Office at Warner Robins Air Force Base. His Telephone No. is 912-926-3284.

They have also had contacts with Harold Summers of PHI Helicopters, who have a large civilian helicopter fleet servicing oil rigs in the Gulf. His Telephone No. is 318-235-2452.

The contact for the Coast Guard at Elizabeth City, where they have been working extensively with PMB, is Mr. White.

Sid Childers at Wright Patterson Air Force Base is knowledgeable in PMB and tends to be on the negative side. He would, therefore, be a useful contact.

Boeing Vertol has been active in PMB use. The contact there is Bruce Thompson, Telephone No. 215-522-2342. The Naval Air Development Center has also been active in evaluation of PMB.

Bob Roberts initiated the work on PMB at Hill Air Force Base. His work is highlighted in the Air Force Corrosion Newsletter.

With regard to the basics of plastic media blasting, the National Parks Service has also been active because of the desire for restoration of statues, reconditioning of building exteriors, etc. A contact in the Park Service who has studied PMB and actually did a thesis on blasting focussing on particle velocity is Nick Veloz, Telephone No. 703-285-2598.

The contact at DuPont for plastic media is Bob Young (302-992-2638).

REFERENCES

Randy Williams also gave us a number of references. He said that he would be glad to supply copies on these if they were appropriately requested through channels. These included the following:

1. Popular Science, July 1982, Page 82. "Xenon Lamp Depainting,"
2. Aviation Week, June 9, 1986.
3. CCAD Plastic Media Paint Stripping Reports and the Defense Environmental Leadership Program Workshop Papers.

Richard S. Lindstrom/ler

15W/222

2156

From.....

Bldg./Room.....Ext.....

MEMORANDUM

To: Armand Balasco

Case 54149-03

Date 01/08/87

Page 9

Subject: Trip Report Corpus  
Christi Army Depot

4. Wear (London) 44, 1977, Pages 311-328. The title of the article is "Particle Size Effects in Bend Erosion," by D. Mills and J.S. Mason.
5. There is also a treatise in Materials Science and Technology, Volume 13, Page 287, on erosion caused by impact solid particles, G.P. Tilly, published by the Academic Press.
6. Proceedings of the Institute of Mechanical Engineers, 1969 and 1970, "Study of Erosion by Solid Particles," by J.E. Goodwin, et al.
7. Aviation Equipment Maintenance, October, 1985, had several articles on PMB.
8. The Corpus Christi people have also put together a red book of photos on their work. The introduction on this is also a good description of their work to date.

Richard S. Lindstrom/ler

15W/222

2156

From.....

Bldg./Room.....Ext.....

MEMORANDUM

To: Armand Balasco

Case: 54149-03 Date: June 3, 1987

Page: 1

Subject: Letterkenny Army Depot Trip Report

CONTACTS

Our primary contact at Letterkenny was Bob Holt in the Environmental Office. His telephone number is 717-267-9690. We also worked with Jody Menges in Production Engineering. His number is 717-267-9506.

MISSION

Letterkenny has a diverse mission for rebuilding Army materiel. The primary focus is heavy-duty trucks in the 2-1/2 to 10 ton classification. However, they also do track vehicles including Caterpillars, self-propelled and towed howitzers, trailers, vans, electronic vans, and shelters; and they also some work on the HEMET. In addition, they are still doing work on World War II vintage guns, which are reworked for use in Europe and for the National Guard. most of the painting now is done with CARC systems using a water reducible epoxy primer.

DEPAINTING PROCEDURES

Most of the depainting of larger parts at Letterkenny is done by blasting with steel shot, walnut shells, or glass beads. They have large vehicle-size booths that utilize steel shot and walnut shells. They use a minimal amount of sand because of the OSHA concerns about silicosis. In the walnut shell booths, they use 70 to 100 psi air, which is not controllable at the booth. They monitor the dust in the booth and have automatic shutdown in order to comply with OSHA safety procedures regarding the use of the walnut shells in manually operated facilities.

They are examining the possible use of Green Lightning or Starblast aggressive abrasives in place of steel shot, glass beads, and walnut shells. One hundred psi air is also used for the steel shot blasting.

For small parts paint removal, which is quite extensive, they have a number of stripper tanks. Some of these use an alkaline stripper, but most use an acid/methylene chloride stripper. There are stripper tanks in five separate buildings with three tanks in one building. These tanks are generally 1,500 gallon capacity.

USE OF PMB

Letterkenny has experimented fairly extensively with plastic media blasting. They have a booth installed in Building 370, which is

From..... Richard S. Lindstrom/ler

15W/222 2156  
Bldg./Room.....Ext.....

MEMORANDUM

To: Armand Balasco

Case: 54149-03 Date: June 3, 1987

Page: 2

Subject: Letterkenny Army Depot Trip Report

approximately 13 by 16 by 12 feet. This booth was supplied by Empire Abrasive Equipment Company in Langhorne, PA. Using the plastic media blasting in this booth, they have developed a significant amount of data which is incorporated in a test report on plastic media blasting, a copy of which was obtained. This is the first study obtained that makes a detailed comparison of ag blasting (walnut shells) versus plastic media.

They find that with the plastic media, they obtain a removal rate of 2 to 3 square feet per minute. The operators much prefer the plastic because of the lower dusting tendency. Also, the walnut shell agricultural media used previously varied in its properties depending on the ambient relative humidity. In order to avoid any steel particles in the recycled media, they have added a strong magnet over which the recycled media passes. The booth has a dual pot system that feeds automatically and an hour meter that records the hours of operation. The plastic media blasting has largely replaced hand sanding. They feel that it will become increasingly useful because they are encountering more and more aluminum. In the large booths, ag blasting is used on some steel; but in order to increase production rates, they may go to a more aggressive media such as the Green Lightning or Starblast.

A plastic media booth utilizes air at 45 psi maximum as compared with 70 to 100 psi in the ag blast booths. Originally, they found that in the plastic media booth they had about 6 pounds per hour consumption of the plastic media. However, as time has passed, this consumption has gone up significantly to the range of 11 pounds per hour. This changes the economics significantly. They believe that increase is due to the operators holding the nozzle closer to the work surface in order to obtain faster removal rates. They are continuing to study the advantages and disadvantages of plastic media.

HAZARDOUS WASTE HANDLING

Blast residue is the biggest single source of hazardous waste. In 1985, they generated 408,000 kilograms and in 1986, 728,000 kilograms of waste which contained up to 10 percent lead and chrome. The waste disposal costs up to September of last year were \$0.36 per pound. Currently, under a new contract, the cost is \$0.18 per pound; but there is a question as to how long this rate will last.

They also have a significant amount of dip tank residue and waste. The dip tanks are drained once per quarter, and they have up to 100,000 pounds of dip tank waste per year. They are in the process of

From..... Richard S. Lindstrom/ler

Bldg./Room.....15W/222.....Ext. ....2156

MEMORANDUM

To: Armand Balasco

Case: 54149-03 Date: June 3, 1987 Page: 3

Subject: Letterkenny Army Depot Trip Report

buying solvent recovery stills which may allow them to recover a percentage of the solvents from the dip tank waste.

The walnut shell (agricultural) blast waste is a borderline toxic material by the EP Toxicity test and could possibly be delisted to reduce disposal costs.

WORKLOAD

The workload at Letterkenny is significant and increasing. Last year there were 450 trucks processed in addition to large amounts of miscellaneous other equipment including 50 artillery pieces. This year they expect the workload on artillery pieces to jump to 200.

OTHER DEPAINTING METHODS

Letterkenny personnel have been following developments in other depainting methods. The only one with which they have specific experience was a test for burning off CARC at a commercial heated fluidized bed facility in New Jersey. It was found that all conventional paints could be removed at lower temperatures, but the CARC was not burned off satisfactorily, even at a temperature of 1000°F.

Richard S. Lindstrom/ler  
From.....

15W/222                      2156  
Bldg./Room.....Ext. ....

MEMORANDUM

To: Armand Balasco

Case: 54149-03 Date: June 3, 1987

Page: 1

Subject: Lexington/Bluegrass Army Depot Trip Report

CONTACTS

Our primary contact at Lexington Depot was Terry Hazle. The visit only included the Lexington Army Depot. Bluegrass is an affiliated facility several miles away, which is primarily ammunition storage and handling and has an extremely low level of activity at the present time. Hazle's telephone number at Lexington is (606) 293-4201. Lexington was nearly shutdown for several years, and now has a complement of about 2,000 people total, as compared with 7,000 people in 1977.

MISSION

The primary mission involving depainting in the Maintenance Directorate at Lexington Depot is shelters and trailers. The Supply Directorate also does some depainting of helicopter parts using MEK and some abrasive (alumina) blasting. At Bluegrass the work is primarily on ammunition. There they use steel shot blasting. At Lexington they have a tenant operator that does some of the work on trailers and shelters. The tenant does his own procurement of supplies and disposal of waste.

DEPAINTING PROCEDURES

The depainting procedures of the Maintenance Directorate involve primarily hand sanding and a limited amount of sand blasting. The helicopter parts, which are done in the Supply Directorate, utilize MEK to soften the paint and then abrasive blasting with 60 mesh aluminum oxide to remove the paint. Almost all the parts done are magnesium forgings at the present time, but they are starting do some aluminum panels.

In the Maintenance Directorate, even the hand sanding is done in a booth because of the concern of the toxicity of the dust generated.

At Bluegrass they have five conveyerized shot blast machines and one ceiling-mounted conveyor through which the munitions pass for blasting. Last year they used about 52,000 pounds of shot but have been relatively inactive this year.

USE OF PMB

The tenant operator, which is E System, is using plastic media blasting on a trial basis for the vans. They have built an enclosure and provided an air blower/dust collection system for that vehicle-size enclosure. In it they are using an Inventive Machines PMB unit that costs \$12,000 and

From..... Richard S. Lindstrom/ler

15W/222 2156  
Bldg./Room.....Ext.....

MEMORANDUM

To: Armand Balasco

Case: 54149-03 Date: June 3, 1987 Page: 2

Subject: Lexington/Bluegrass Army  
Depot Trip Report

uses a water trap for dust collection. They blasted 40 to 60 psi using Polyplus 12-20 mesh material. They obtain a GSA contract price on the blast media. They recycle the media, but they are looking at the possible trade-off of not recycling the media because they find that the recycled media cuts much more slowly than the virgin media. This approach was somewhat surprising in view of the high cost of the media. However, they indicated that they save about 30 man-hours on a van. It normally takes six people two to three days to hand sand the van. They feel that overall they save about \$400 per van using plastic media blasting. The Inventive Machines unit is a push-pull type which has a vacuum collection system around the nozzle. However, they do not always use the vacuum collection system because they are working in an enclosed booth. They find that the water collector on the vacuum blast unit is very efficient. The collected dust from the booth dust collector and from the wet collector on the Inventive Machines unit are toxic on the basis of cadmium, chromium, and lead content.

HAZARDOUS WASTE HANDLING

Because of the small quantities that are generated, the blasting waste from the Maintenance Directorate and Supply Directorate are tested for toxicity only once every six months. Occasionally, they pass as being non-toxic, but usually they are toxic; and, therefore, they are always disposed of as toxic waste. Last year they disposed of about 100 cubic yards of material at a cost of \$17,000.

WORK LOAD

No figures were available on the amount of material processed through Lexington/Bluegrass, but clearly it is low; and the depot is only slightly above standby status.

OTHER DEPAINTING METHODS

Terry Hazle has been following the developments in alternative painting methods; but because of the low amount of depainting done and the low amount of waste generated, he has not pursued these actively.

From..... Richard S. Lindstrom/ler

Bldg./Room..... 15W/222 Ext. .... 2156

MEMORANDUM

To: Armand Balasco

Case: 54149-03 Date: 01/08/87

Page: 1

Subject: Red River Army Depot Visit  
(Texarkana, Texas)

CONTACTS

Our primary contact during our visit at Red River Depot on November 19, was Mr. Ed Hanna of the Engineering Department. His Telephone No. is 214-838-3658. Our guide for the day was Mr. Billy Thornton. We also talked with Ralph Lindsey of the Hazardous Waste Office. His Telephone No. is 214-838-3559. Carol Gannoway, who works for Ralph, provided the figures on the hazardous waste. We also talked with T. Dwight Owen of the Production Control Division regarding workload.

MISSION

There are three directorates at Red River. Maintenance is the primary directorate that is utilizing paint removal facilities. They are primarily concerned with the IRAN and overhaul of the M113 family of personnel carriers and the new Bradley fighting vehicle. In addition, they do smaller quantities of mil vans and missile containers. The second directorate is supply, and they normally do no maintenance functions. However, they are sometimes involved with some limited work on stored vehicles before they are shipped and are considering installation of a blast and repaint facility for touch-up and color change, etc. The ammunition directorate in the past has been concerned with reconditioning of munitions, but very little of that is going on at the present time. Mr. Morris Granberry, with whom we talked within that branch, indicated that they do have Wheelabrator machines, turntable blast machines, a blast room, and chemical cleaning facilities that could be activated, although they are inactive at the present time.

DEPAINTING PROCEDURES

In the maintenance directorate, they currently have about 50 glove boxes where small-scale blasting is done both for cleaning and for repainting purposes. These utilize various media including sand, shot, shells and glass beads. They also have two large vehicle booths and four additional walk-in booths that can be used for repainting large parts. All of these use sand as the abrasive medium. They also have a number of Pangborn and Wheelabrator shot blasting machines of the centrifugal type.

When the vehicles arrive for maintenance, they are first steam-cleaned and then disassembled. The hulls are moved to the vehicle blast booths where they are sand blasted. The hulls are heavy aluminum on which steel shot cannot currently be used because it leaves steel smears on the aluminum which initiate corrosion. They have one large new Pangborn sand blast room with a shallow pit vacuum recovery system. This facility cost

From..... Richard S. Lindstrom/ler

Bldg./Room..... 15W/222 Ext..... 2156

MEMORANDUM

To: Armand Balasco

Case: 54149-03 Date: 01/08/87

Page: 2

Subject: Red River Army Depot Visit  
(Texarkana, Texas)

\$450,000 complete with concrete slab. The other vehicle and walk-in cleaning booths are in relatively poor condition primarily because a large new facility is in the final stages of construction. When it begins operation in 1987, most of the disassembly, cleaning, painting, and reassembly operations will be consolidated under a single roof. The new building, which is about 250' x 750' in size and cost \$50 million, has two walk-in booths as well as a large bay for automated blasting of the vehicle hulls. In this bay, the hull is actually picked up and held vertically while being centrifugally blasted with stainless steel shot. The stainless steel does not leave an objectionable smear on the aluminum. However, there are concerns about the durability and cost of the stainless steel shot. The cost is over \$2 per pound.

If low durability of the stainless steel shot becomes a cost problem, they will look further into the feasibility of using steel shot. This may require modification of downstream chromating, and other corrosion protection systems to assure that steel smears do not initiate corrosion on the aluminum hulls. They have already been doing some work on road wheels for the M-113 vehicles using steel shot for depainting and have not encountered corrosion problems. However, the road wheels are a different aluminum alloy than the hulls. The walk-in booths in the new facility will use sand or a suitable non-silica abrasive such as the peridot-based abrasive.

In the past some of the walk-in booths have utilized walnut shells. However, according to Ralph Lindsey, these are no longer used in order to comply with OSHA Standard 1910.94a2iii. The CARC paint systems have been in use for about two years at Red River. A limited number of vehicles with the CARC systems have come back for work in that period. The CARC is somewhat more difficult to remove even with the sand blasting, with the blasting rate about half that of the previous alkyd paint system. On the other hand, these new systems do not contain lead and, therefore, have less heavy metal contamination. As a result, the spent blasting media may not have to be classified as hazardous waste.

For engine parts and other small components, some chemical stripping is done. However, this is all done in dip tanks. There is no spray-on/wash-off chemical strip process for large vehicles or parts utilized at Red River.

The current cost of sand, the primary blasting abrasive, is \$34-40 per ton. However, there is serious concern that the sand will be banned because of the dust hazard and silicosis problems that it creates. Red River is, therefore, looking seriously at alternatives. They have

From..... Richard S. Lindstrom/ler

Bldg./Room..... 15W/222 Ext..... 2156

MEMORANDUM

To: Armand Balasco

Case: 54149-03 Date: 01/08/87

Page: 3

Subject: Red River Army Depot Visit  
(Texarkana, Texas)

evaluated copper slag-type blast media. However, these tended to imbed in the aluminum and cause potential corrosion problems. They are in the process of evaluating the peridot-based abrasive which is being used at Anniston. The cost of this is about twice the cost of sand. However, it is more durable and can be recycled. Therefore, the increased cost may be offset by the increased durability. It is presently the best alternative to sand. They have looked at high pressure water blasting as an alternative but found that it is not effective, even if some sand is added to the water.

The currently used top coat for the exterior of the vehicles is a urethane specification Mil-C46168. On the inside they use an epoxy which provides the same agent protection as the urethane but does not have UV resistance and is cheaper than the urethane. This is Mil-C22750. Prior to painting, the hulls are treated with a spray-on chromate conversion coating, Mil-P53022. They are then coated with an epoxy primer which is used on both steel and aluminum. The only material other than steel and aluminum that is depainted is magnesium which is used in the final drive housing. However, this is a very small portion of the total depainting commitment and can be done in dip tanks.

USE OF PMB

Because of the concern about the banning of sand blasting, Red River has been looking at plastic media blasting. To date, they have tried it only in glove boxes. They find that the rate of removal of paint is better than with walnut shells, which they no longer use except in glove boxes, but significantly less than sand. Unless sand is banned, they feel that the plastic media at \$2.15 per pound is unlikely to be cost effective in comparison with a \$40/ton sand. They expressed concern about the high degradation rate of the plastic media observed in their trials in view of its cost. If sand is banned, the peridot abrasive represents the most promising alternative. In addition as noted previously, they are planning to use stainless steel shot for the hull blasting in the automated hull blasting bay of the new maintenance building.

HAZARDOUS WASTE HANDLING

Because recycling systems in some of the blasting booths are not operative, there is some sand which is not recycled. That sand passes EPA requirements for heavy metal contamination and can be land filled. In the past Red River has utilized some natural clay lined pits for disposal of hazardous wastes. However, these are now filled and closed. The dust from the sand blasting operations has sufficient heavy metal content to

From: Richard S. Lindstrom/ler

Bldg./Room: 15W/222 Ext.: 2156

MEMORANDUM

To: Armand Balasco

Case: 54149-03 Date: 01/08/87

Page: 4

Subject: Red River Army Depot Visit  
(Texarkana, Texas)

be classified as a hazardous waste under EPA regulations. This dust fails the test on the basis of high chromate content. The dust is collected from the cyclones in dumpsters. It is mixed with the sludge from the electrical plating waste and is disposed of as hazardous waste. Under the previous contract, the cost was \$85 per ton; under the new contract, it is \$153 per ton. Figures obtained from Ralph Lindsey indicate that from September, 1985 through October, 1986, a total of approximately 120 tons of dust was disposed of at a cost of \$18,337.

WORK LOAD

The throughput at Red River is normally five vehicles per day. They are programmed for 1,300 vehicles in 1987, which is down from a total near 2,000 in earlier years. They will also be doing about 460 missile containers which are done with steel shot, and 1,000 to 1,300 engine containers which are also done with steel shot. As yet, an undetermined number of mil vans will also be done.

CONCLUSIONS

Attached is a summary of the thoughts at Red River regarding plastic media blasting which were put together by Ed Hanna in November of 1986. The conclusions speak for themselves in that plastic media is slower than sand but faster than walnut shells in removing paint from the aluminum. The plastic is safer and more environmentally acceptable than sand. They have found that the plastic breaks down at a faster rate than sand and that the plastic cost is \$2.15 per pound compared with \$.02 for sand. Even if sand is banned, they have the alternative of the peridot abrasive. Also in the new facility for the large hull blasting, they are going to stainless steel shot with centrifugal throwers with some question marks as to what the economics will be there. Overall, they really see no driving force pushing them toward PMB at the present time.

From..... Richard S. Lindstrom/ler

Bldg./Room..... 15W/222 Ext..... 2156

## POINT PAPER

•SUBJECT: Plastic Media Blasting

•PURPOSE: To determine if plastic blast media is a safe and effective method of paint removal from Army vehicles and components.

•FACTS:

RRAD performs extensive blasting operations on aluminum and ferrous surfaces.

Blasting media used were steel grit and shot, silica sand, glass beads, walnut hulls.

Steel shot can set-up corrosion cells on aluminum.

Silica sand is inexpensive and safe for use on aluminum but environmental and hygiene standards governing its use are becoming increasingly restrictive.

Walnut hull use has been eliminated in compliance with OSHA Std. L910.94(A)2III.

Glass beads are expensive and not suitable for some abrasive cleaning requirements.

Plastic media is one of several materials being evaluated by RRAD as a replacement for silica sand.

RRAD has sent representatives off depot to demonstrations utilizing plastic media.

RRAD has allowed companies to demonstrate plastic media blasting on depot.

RRAD has received proposals from various equipment and media manufacturers for installations at RRAD.

RRAD has concluded the following:

Plastic media is slower than sand but faster than walnut hulls in removing paint from aluminum.

Plastic media is safer and more environmentally acceptable than sand.

Plastic media breaks down to unuseable particles much faster than sand.

Plastic media cost is approximately \$2.15 per pound. Sand cost is about \$0.02 per pound.

EDWARD R. HANNA/3658

MEMORANDUM

To: A. Balasco

Case: 54149-05 Date: 3/2/87

Page: 1

Subject: Trip Report - Sacramento Army Depot

CONTACTS

Our primary contact at Sacramento Depot was Pat Christman, Environmental Coordinator. His telephone number is (916)388-3248. We also met with Bill Anderson, who is General Foreman, Material Coating Section, Maintenance Directorate who toured us through the facilities. His commercial number is (916)388-2818. His Autovon number is 839-2818.

MISSION

The primary mission of the Sacramento Depot is electronic systems overhaul and maintenance, including shelters and containers for the electronics systems.

DEPAINTING PROCEDURES

Sacramento uses sandblasting for paint removal for the exterior of the shelters and hand-sanding on the interior. The interior cannot be sandblasted due to potential damage to wiring, vents, and other fragile components. They do not do any chemical stripping except in dip tanks. Their work also includes some stripping and repainting of vehicles. The sandblasting is done in one vehicle booth and four glove boxes.

In addition to the problem of damage on the interior of the shelters, they say it is very difficult to blow sand out of interstices. On the exterior, the sand has the disadvantage that it is so aggressive that it tends to warp the faces of some of the honeycomb panels if great care is not used.

They have found that it is not economic to recycle sand. The sand becomes rounded so that it generates heat that can warp the aluminum panels. It also cuts more slowly so that it is not cost effective to reuse the low cost sand given their high labor costs.

USE OF PMB

SAAD personnel believe that PMB fits very well with the electronics equipment that they work on. Their experimental work indicates that it can be used with proper controls on encapsulated printed circuit boards and even for removal of silicone rubber from a delicate night vision instrument. Otherwise, this particular stripping problem is extremely difficult and time-consuming. The close control of PMB allows removal of one layer of paint at a time with little or no damage to the substrate.

From..... Richard S. Lindstrom/ler

Bldg./Room..... 15W/222 Ext..... 2156

MEMORANDUM

To: A. Balasco

Case: 54149-05 Date: 3/2/87

Page: 2

Subject: Trip Report - Sacramento Army Depot

It can even be used on stainless steel, which tends to warp because of its low thermal conductivity according to their findings.

Eighty to eighty-five percent of the material depainted at Sacramento is aluminum on which the PMB is very cost effective, according to their studies. This is because the PMB can be used on the interior of the electrical cabinets without damaging wiring or other delicate components. The very high labor cost of hand-sanding the interiors more than offsets the higher costs of the plastic blasting media. In addition, the plastic media is easily blown out of interstices.

As a result of favorable experience in trials to date, Sacramento Depot is planning to install a PMB vehicle-size booth which will be 36' long x 32' wide x 15' high. Specifications are currently being prepared by the Corps of Engineers. It is anticipated that bids will be requested by June 1987 and award made by August 1987 for a construction period of approximately 12 months before the facility is on-stream. They have estimated \$300,000 for the turn-key facility.

HAZARDOUS WASTE HANDLING AND ENVIRONMENTAL PROBLEMS

The sandblasting operations generate 300+ tons per year of spent sand which is not now classified as hazardous waste based on California and EPA toxicity tests. The leachable toxic materials are very low because the sand is not recycled in the blasting operation. In spite of the fact that it is classified as non-toxic, it is increasingly difficult to dispose of the spent sand because of the severe limitations on the creation of new landfill sites. In addition, the indications are that new county, California and EPA regulations will make any waste from depainting operations a hazardous waste by the early 1990's, and this will create severe problems due to costs for disposal of the spent blast media. Since the volume of spent media will be much lower with PMB than with sand, the disposal problem should be less severe with the plastic media.

As an example of rising waste disposal costs, Christman pointed out that hazardous wastes containing any chlorinated solvents must be incinerated according to current regulations, and the only incinerators authorized for this use are in Louisiana, Arkansas, and Texas. As a result, the disposal costs of wastes from tank paint stripping operations which contain chlorinated solvent cost as much as \$800 per 55-gallon drum for disposal. Christman anticipates that when all the painting waste becomes hazardous waste, costs will be over \$100 per drum for disposal of the

From..... Richard S. Lindstrom/ler

Bldg./Room..... 15W/222 Ext..... 2156

MEMORANDUM

To: A. Balasco

Case: 54149-05 Date: 3/2/87

Page: 3

Subject: Trip Report - Sacramento Army Depot

spend media. Thus, minimizing the volume of waste through the use of PMB should be cost effective.

In addition to the hazardous waste disposal problem, Sacramento Depot is facing severe constraints and environmental problems with regard to VOC's from their painting operations. They must severely limit the amount of VOC emissions from their painting operations. In attempts to comply, they have gone to high solids and water-based paint systems to the extent possible. They are also attempting to reduce paint usage by going to electrostatic spraying. Currently, they are getting only 40 to 45 percent transfer efficiency of the paint, whereas a good operating electrostatic system should provide at least 65 percent transfer efficiency.

They are also attempting to limit the amount of painting--doing touch-up only where possible--instead of full repainting jobs. They speculate that the use of PMB, with the capability to remove surface paint while leaving primers and corrosion protection systems in tact, may assist in reducing the amount of painting that they have to do. For their painting, Sacramento is currently using primarily the CARC systems. At present they are using two-component CARC paints which are pot mixed. They realize that one component would be more convenient and are looking at them.

The new systems utilize, in some cases, barium sulfate as a filler in the primer, and questions have been raised regarding the effect of the barium sulfate on the toxicity of the paint waste from both application and from depainting operations. The barium sulfate should be sufficiently insoluble to have no toxic effect.

Sacramento has been working with a liquid, non-hazardous paint stripper and is assembling documentation through their environmental counsel. However, this work is still in the experimental stage, and there is some question as to whether the stripper will be fully effective on paints that are hard to strip such as the CARC systems. They currently drum their used spray booth filters for disposal.

WORK LOAD

The average shelter size that is painted at Sacramento is 8' x 8' x 16'. They average 600 to 700 of these painted per year, and each shelter is essentially stripped and painted twice--once for the exterior and once for the interior. There is also some stripping of components and of

From..... Richard S. Lindstrom/ler

Bldg./Room..... 15W/222 Ext..... 2156

MEMORANDUM

To: A. Balasco

Case: 54149-05 Date: 3/2/87

Page: 4

Subject: Trip Report - Sacramento Army Depot

vehicles as previously noted. However, the primary work load is the shelters.

WORK WITH OTHER DEPAINTING SYSTEMS

The only other depainting system that Sacramento has looked at is the flash lamp system which is being evaluated at McClellan Air Force Base. They believe this system is very cumbersome and inefficient, even though one would expect it to be much more applicable to the relatively flat-sided shelters as opposed to aircraft which have a very complex shape.

OTHER REFERENCES

With regard to the hazardous waste characteristics of the paints, they referred us to the Federal Register, Volume 51, #9; January 14, 1986. Other documents that Christman suggested that might be of use to us include the "Governor's 1986 Task Force Report on Toxic Waste and Technology." This was requested from the State Public Information Department, telephone (916)324-1789. Another reference was entitled, "Alternative Technology for Recycling and Treatment of Hazardous Waste." The Second Biennial report issued in July 1984 was requested from the Technology Branch, telephone (916)324-1807, and is being sent along with the Third Biennial Report, dated July 1986.

Christman also referred us to Title 22 for the California list of hazardous materials.

From..... Richard S. Lindstrom/ler

Bldg./Room..... 15W/222 Ext..... 2156

MEMORANDUM

To: A. Balasco

Case: 54149-03

Date: April 13, 1987 Page: 1

Subject: Tobyhanna Army Depot

Contacts

Our primary contact was Steve O'Mally, an industrial engineer in Maintenance Engineering. His telephone number is (717) 894-7008. Our tour through the facilities was conducted by Joe Ruane (ext. 7498), who is in charge of preparation in the paint shop. His supervisor is Jack Burns, who is the Chief of the Sandblasting Unit. We also talked with Ted Krolick who is the Chief of Electroplating and with Ed Slimack who serves as Environmental Officer.

Mission

The work at Tobyhanna is almost entirely in the communication and electronics area. The primary depainting is on shelters. They also do trucks, trailers, and vans that are used to carry the electronics equipment, a limited number of milvans, generator trailers, etc.

Depainting Procedures

Most of the depainting done at Tobyhanna is hand sanding with vibrating sanders. They believe that the hand sanding is more efficient for partial paint removal which is done in many of cases on the equipment that they overhaul. They also prefer hand sanding because of the problems of damage to the shelters if blasting is used with inadequate control. The blasting requires a higher skill level than the hand sanding because of the potential for doing damage. Also, when they use blasting, they remove much of the sealant which must then be replaced by the sheet metal workers, who do the repairs on the shelters adding to the repainting costs. They have two blasting areas at the depot, one booth in the main sandblast shop. This booth is about 15'x15', and they use aluminum oxide as a blasting medium. It that area they also have a number of glove boxes which also utilize aluminum oxide. They also have a Rotoblast machine in which they use No. 50 steel grit. They do not use glass bead and walnut shell blasting at Tobyhanna.

In the paint shop in Building 9, they also have a 15-foot square booth which was recently changed from steel shot to aluminum oxide in anticipation of an increase in the workload of shelters. This unit was previously used for vehicles and other steel materiel. This was a controversial change because the anticipated workload in shelters has not materialized, and they find that they are using a much larger quantity of aluminum oxide then was the case with the steel grit as a blasting medium.

From..... Richard S. Lindstrom/ler

Bldg./Room..... 15W/222 Ext. .... 2156

MEMORANDUM

To: A. Balasco

Case: 54149-05

Date: April 13, 1987 Page: 2

Subject: Tobyhanna Army Depot

They find that they are limited in their ability to blast shelters because of the panel warping damage to the shelters. The doors, vent louvers, and other areas if thin metal cannot be blasted without damage unless a blaster uses great skill. They are currently using an aluminum oxide that contains 0-3 percent titanium oxide and have experimented with another alumina as a more durable alternative. Even for those shelters that are blasted on the outside, they are usually hand sanded on the inside because all of the wiring is not removed, and abrasive blasting creates a problem.

On a typical shelter, two days of hand sanding may be required on the outside, while the outside can be blasted in about 4 hours. However, because of safety regulations, they must have one man on the outside of the booth observing the man in the booth. Thus, it takes 8 man-hours to do the same amount of blasting that could be done in 16 hours by hand sanding with lower level people, and possible damage to the shelter is avoided. They have depainted a few shelters with CARC paint on them, and they find this significantly more difficult to remove. Small parts are done in chemical strip dip tanks in the plating shop which uses a formic acid/methylene chloride stripper. They remove about one drum of sludge per month from the dip tank, and when it is replaced about every six months, nine drums of waste are generated.

Use of PMB

Steve O'Mally has been following the development of PMB, but they have have not done any work with PMB up to the present time.

Hazardous Waste Handling and Environmental Problems

The amount of hazardous waste that is generated at Tobyhanna is relatively small. Since the main sandblast booth in Building 9 (paint shop) has been converted from steel grit to aluminum oxide, the amount of waste has increased significantly. However, the aluminum oxide is recycled a number of times. It is presumed to be hazardous, but they do not have leachability tests run on it to determine whether it is hazardous or not. It is drummed and disposed of in a hazardous waste landfill. Steve O'Mally is going to obtain information on the quantities of aluminum oxide consumed and the amount of waste shipped out, as well as the cost of the waste disposal.

The only other hazardous waste connected with depainting operations comes from the methylene chloride stripper dip tank in the electroplating shop. They remove an average of about one drum of sludge per

From.....  
Richard S. Lindstrom/ler

15W/222      2156  
Bldg./Room.....Ext.....

MEMORANDUM

To: A. Balasco

Case: 54149-09

Date: April 13, 1987

Page: 3

Subject: Tobyhanna Army Depot

month from that bath, and when it is periodically replaced--which is not more than once a year--about nine drums of waste are generated. Steve will also get numbers on the exact quantities and cost of disposal of that waste from the Property Disposal Officer at the depot.

They are planning to install a recycling still, but that will be used primarily for the trichloroethylene that is used in the degreasing and cleaning facilities and not for the methylene chloride in the stripper.

Workload

The primary depainting workload at Tobyhanna is communication shelters and portions of those shelters. They have been doing about 200 per year of these and have been advised by the planners to anticipate a workload of 1,000 to 1,500 per year, but this has not materialized. Some of it may be going to the Lexington Depot on a bid basis. They also do numbers of milvans and trucks that are used for transporting communications shelters and trailers and generator trailers. However, Steve was not able to give me figures on the workload in these others types of materiel.

Work with Other Depainting Systems

Tobyhanna has been doing little or no work with other depainting systems. Steve noted that there was a reference in Technical Manual 430139 or 43-139 on PMB use which would be of possible interest to us.

From..... Richard S. Lindstrom/ler

Bldg./Room..... 15W/222 Ext. .... 2156

MEMORANDUM

To: Armand Balasco

Case: 54149-05 Date: 3/4/87

Page: 1

Subject: Tooele Army Depot Trip Report

CONTACTS

Our primary contact at Tooele was Rudy Verzuh. His telephone number is 801-833-3474.

MISSION

The mission of Tooele Army Depot is the maintenance and overhaul of trucks including engines, transmissions and axles; generators of all sizes and types, and multi-purpose units that supply heating, air-conditioning, and power for portable shelter units, including field hospitals.

DEPAINTING PROCEDURES

Because of the nature of the work at Tooele and the very large numbers of moderate to small size parts, vapor degreasing and dip tank stripping and cleaning are commonly used. The larger parts are steam cleaned and then blasted with steel grit to remove both paint and corrosion. For the more delicate parts of aluminum and other soft metals, the blasting is done with walnut shells with which aluminum oxide is sometimes mixed to provide an increased aggressiveness for the removal of corrosion as well as paint. The amount of the various types of media used and the cost of each in an 11-month period, January 1986 through November 1986, is as follows:

<u>Media Type</u>	<u>Amount Used (Pounds)</u>	<u>Purchase Cost Per Pound (\$)</u>
Walnut shells	97,250	0.11
Aluminum oxide	77,600	0.34
No. 50 steel grit	10,335	0.21
No. 25 steel grit	76,500	0.30

The walnut shells and aluminum oxide are used in two blast rooms and several small cabinet blasters. The steel grit is used in a large blast room and in three tumble blasters and one table blaster.

The operating procedures at Tooele forbid the blasting of any parts with oil passages even though in the commercial world such blasting is done. This includes parts such as cam shafts, engine blocks, and particularly automatic transmission housings. Rudy noted that at Red River and possibly Corpus Christi parts having oil passages are blasted. These are

From Richard S. Lindstrom/ler

Bldg./Room 15W/222 Ext. 2156

MEMORANDUM

To: Armand Balasco

Case: 54149-05 Date: 3/4/87

Page: 2

Subject: Tooele Army Depot Trip Report

properly masked and/or checked with fiber-optic devices after blasting to assure that blast media is not left in the oil passages. It was noted that on some types of equipment it would be technically feasible to spot clean to remove deteriorated paint and/or corrosion and then spot paint to provide corrosion protection with a final overall cosmetic coat. However, the difference is visually apparent, and field commanders tend to resist receiving overhauled equipment that is not totally stripped and repainted.

USE OF PMB

As a result of a TROSCOM report, which indicated that PMB was the preferred way to strip, a number of trials with plastic media have been run at Tooele using plastic media in glove box applications. They also sent a truck to Hill to be blasted. The cost of the plastic media and adjustment of equipment to properly recover the media were problems. The durability also seemed limited. In addition, the plastic did not show great improvements in paint removal rate over other soft media, although some reduction in masking requirements might be possible with plastic media. The results on the trucks were mixed in that paint removal was effective, but it was clear that the plastic media blasting would not remove any heavy corrosion deposits on the trucks. The Tooele people would like to do more blasting but are not sure at this point how cost effective it is. They would like to have an updated data base on depainting that would allow them to follow developments and provide a basis for requesting new facilities. Because of the low recycling rate problems and high media cost, a facility for plastic media must clearly be designed specifically for PMB if it is to be efficient.

HAZARDOUS WASTE HANDLING

The lead and chrome content of the dust resulting from the blasting operations makes the dust a hazardous waste. In fiscal year 1986, the hazardous waste disposal included 210 drums of steel dust and 566 drums of walnut dust at a cost of \$50 per drum. However, the company that had the waste disposal contract for \$50 per drum is no longer in business, and future contracts are estimated to cost between \$65 and \$85 per drum.

Because of the large amount of dip tank cleaning that is done, there is between 15,000 and 20,000 gallons per day of wastewater generated as a result of rinsing of parts. Currently, the wastewater is put into a waste pond. However, this pond is causing considerable environmental concern, and there are some plans for a treatment plan. In the meantime,

From..... Richard S. Lindstrom/ler

Bldg./Room..... 15W/222 Ext..... 2156

MEMORANDUM

To: Armand Balasco

Case: 54149-05 Date: 3/4/87

Page: 3

Subject: Tooele Army Depot Trip Report

an effort is being made to reduce the chlorinated organic content of the wastewater by air-stripping the water prior to putting it into the wastewater system.

It is interesting to note that Tooele has developed a unique system for handling the dry filters from their paint booths. Instead of drumming them for disposal, as is the case as other depots, they run the filters through the dip tanks to remove the paint. They then dry the filters and reuse them.

WORK LOAD

The work load in man-hours for the various types of equipment at Tooele are shown in the attachment to this memo which is data provided by Rudy Verzuh. I am trying to obtain additional data on the portion of the man-hours indicated for the various items that is devoted to depainting. Rudy indicated that they would very much like to replace the dip tank cleaning with another method that generates less hazardous waste such as plastic media blasting. However, because of the large number of small parts handled, some type of automated equipment for accomplishing the blasting would be necessary. They indicated that Zero Manufacturing is examining the possibility of converting their BNPA200 table machine to utilize plastic media. Rudy also mentioned the GOFF Corporation and Pangborn as companies interested in automated plastic media blasting.

OTHER DEPAINTING METHODS

As an alternative to steam cleaning, vapor degreasing and tank cleaning, Tooele has been experimenting with hot air carbonizing systems for both steel and aluminum parts. These can be used to reduce both the grease and paint on the parts to a carbon residue which can then be easily wiped or blown away. Equipment they have been examining is from Pollution Control Products Company, 2677 Freewood Drive, Dallas, Texas 75220.

From..... Richard S. Lindstrom/ler

Bldg./Room..... 15W/222 Ext..... 2156



PROJECTED WORKLOAD - POWER GENERATION BRANCH P2 OF 2  
 APRIL 29, 1995 T.MCCARTHY

COMMODITY	FY34	FY34	QTY	FY36		FY37		FY38		FY39		FY90		FY91		FY92		FYE
				FY36	FY37	FY38	FY39	FY90	FY91	FY90	FY91	FY91	FY92					
CC5C730 BLDG 611																		
GEN 5KW 60HZ GE	735	52346	1546	110159	1592	113399	1537	115639	1633	119879	1728	123119	1774	12611				
GEN 5KW, 2, P2-618/M	25	5952	53	14693	55	15125	56	15557	53	15999	60	16421	61	16843				
GEN 10KW 60HZ SKID	106	7095	222	14741	229	15175	235	15603	242	16042	248	16476	255	16908				
GEN 5KW, 2, P2-520/M	15	3634	32	7590	33	7916	34	8242	35	8569	36	8895	37	9221				
GEN 10KW, 2, P2-619/M	53	3237	63	19213	71	19459	74	20025	76	20592	78	21158	80	21724				
GEN 5KW, 2, P2-520/M	31	3230	65	7377	67	6995	69	7195	71	7395	73	7595	75	7795				
GEN 10KW, 1, P2-322A/322	66	13058	139	27490	143	28228	147	28977	151	29905	155	30712	159	31520				
GEN 5KW 100HZ SKID	33	1746	69	3574	71	3722	74	3890	76	3993	78	4105	80	4217				
GEN 10KW 250/50, SKID	11	1150	23	3277	24	2447	25	2517	26	2557	27	2637	28	2717				
CYL 573, G-5	2151	2563	4526	5394	4659	5552	4792	5711	4925	5870	5053	5121	5291	5461				
GEN 10KW, 1, P2-304/C	10	4318	21	10191	21	10430	22	10769	23	11079	23	11379	24	11679				
GEN 5KW, 2, P2-521/3	3	2317	7	5295	7	5432	7	5608	8	5764	8	5920	9	6076				
GEN 10KW, 100HZ, SKID	20	1542	42	3456	43	3559	44	3659	45	3761	47	3863	43	3965				
SUBTOT		102696		230951		237641		244431		251220		258010		264800				
CC5C740 BLDG 600																		
POWER PLANT UTILITY	55	43303	116	36220	119	39475	123	42033	126	44599	129	47146	133	49693				
A/C 3800 BTU	15	16524	32	39373	33	40125	34	41271	35	42413	36	43561	37	44704				
FESTER, EGI	66	11544	139	24503	143	25224	147	25945	151	26665	155	27386	159	28107				
PUMP, POL CED F-GEN	165	9863	350	20755	360	21356	370	21976	380	22597	391	23197	401	23817				
TEST STAND H/D	15	5530	32	11537	33	11979	34	12422	35	12864	36	13305	37	13747				
RANGE SQUAD SUPPORT	118	1782	243	3750	255	3860	262	3971	270	4081	277	4191	284	4301				
RWR PACK COMPONENTS	179	15639	377	35015	388	36045	400	37075	411	38105	422	39135	433	40165				
P/U 3KW STGE	90	5329	190	18579	195	19125	201	19672	207	20219	212	20765	218	21312				
FILTER SEPARATOR	43	2163	90	4563	93	4697	96	4831	98	4965	101	5099	104	5233				
TEST SET ELECTRIC	212	1190	447	2505	460	2578	473	2652	485	2726	499	2799	512	2873				
FEFRIDRATOR UNIT	11	524	23	1417	24	1517	25	1613	25	1713	26	1819	27	1924				
FESTER, LEAKAGE H/D	5	1033	12	2174	12	2238	12	2302	12	2365	13	2429	13	2492				
FUEL CONTROL	23	799	59	1691	60	1730	61	1779	63	1829	65	1878	66	1927				
ENGINE, GAS TURBINE	3	1132	7	2382	7	2452	7	2522	8	2592	8	2662	8	2732				
PUMP LOL GED 350324	11	2255	23	4310	24	4552	25	5093	25	5235	26	5375	27	5515				
TANK AND PUMP UNIT	8	1198	16	2521	17	2595	17	2669	18	2743	18	2818	19	2892				
TANK AND PUMP UNIT	2	1001	5	2107	5	2169	5	2230	5	2292	5	2354	5	2415				
EEJ A1/M10-21 60KW	7	6032	14	12799	14	13176	15	13552	15	13927	16	14305	16	14683				
GT ENG	7	1470	14	3093	14	3184	15	3275	15	3366	16	3457	16	3548				
COMPRESSOR WK	11	1756	23	3695	24	3803	25	3912	25	4021	26	4129	27	4238				
SUBTOT		135847		295883		294292		302700		311108		315517		320926				
PWR GENERATION BRANCH TOTAL		735604		1069815		1101280		1132745		1164210		1195676		1227141				



PROJECTED WORKLOAD - POWER GENERATION BRANCH P1 OF 2  
 FY 84 INCREASED BY 10% TO ACCOUNT FOR UNLISTED HOURS.  
 APRIL 29, 1985 T.MCCARTHY

COMMUNITY	SIC	CITY	LAUSD	HRS	FY86		FY87		FY88		FY89		FY90		FY91		FY92	FY	
					QTY	HRS	QTY	HRS	QTY	HRS	QTY	HRS	QTY	HRS	QTY	HRS			
POWER GENERATION	805				1,253	1,295	1,295	1,332	1,369	1,405	1,443								
					1	1	1	1	1	1	1								
					2	2	2	3	2	2	2								
ENG MEE, 20HP, 3AS		1655	72365																
ENG MEE, 10HP, 3AS		413	14236																
ENG 6HP VIL STD		1121	41537																
ENG 2HP VIL STD		594	13547																
ENG 1.5HP VIL STD		1309	74572																
		227247																	
SUBTOT					52	29503	60	30376	60	30376	60	30376	60	30376	60	30376	60	30376	
CC55710 BLDG 500					1243	95501	1284	92413	1284	92413	1321	101224	1358	104235	1355	106656	1355	106656	
P/U 3KW ST GE		35	14022																
GEN 3KW 60HZ GE		595	45424																
GEN 1.5KW AC		292	13912																
GEN 3KW ST GE		114	11332																
GEN 3KW 22V GE		157	11105																
P/U 3KW 60HZ TRANS		33	14419																
GEN 1.5KW DC		53	11111																
		211228																	
SUBTOT					93	56336	95	63802	95	63802	93	70557	101	72724	103	74599	103	74599	
CC55720 BLDG 602					100	41402	102	42620	102	42620	105	43337	109	45055	111	45773	114	47111	
GEN 60 KW/60HZ		44	31759																
GEN 60KW		47	19674																
P/U 650B/G GEN 60KW		24	16538																
GEN 30KW/400HZ		51	22387																
GEN 100KW/60HZ		18																	
P/P 20 KW/10 GEN 30		16	3377																
GEN 30 KW/50HZ		10																	
GEN 60KW/60HZ		4506																	
P/U 707 GEN 60KW		20	4532																
LUBE UNIT		13	22465																
RANGE STAAD SUPPORT		25	13533																
LUBE UNIT		232	4533																
F/P 20 HJ15		10	11791																
P/P 200K 60HZ		8	6559																
CYN 1200		3	4562																
NAVY POWER UNIT		2	2732																
P/U 699.4M GEN 60KI		11	2066																
P/U 495A/G GEN 100		7	3331																
TANK, LIQUID STORAGE		2	1746																
P/U GEN 60KW/60HZ		23	1713																
PLC		2	2247																
SUBTOT			151487		42	3537	43	3518	43	3518	44	3093	45	3379	47	3659	48	3939	
					22	4727	29	4363	29	4363	29	5058	30	5149	31	5239	32	5329	
					56	2951	57	2935	57	2935	59	3074	61	3122	62	3206	63	3286	
					498	9549	503	9330	503	9330	517	10111	532	10392	546	10672	550	10952	
					21	24813	21	25543	21	25543	22	26273	23	27003	23	27733	24	28463	
					16	13804	17	14210	17	14210	17	14516	18	15022	18	15428	19	15834	
					7	6760	7	9017	7	9017	7	9275	8	9532	8	9790	9	10048	
					5	5750	5	5919	5	5919	5	6088	5	6258	5	6427	5	6597	
					23	4347	24	4475	24	4475	25	4603	25	4731	25	4859	27	4987	
					14	7010	14	7216	14	7216	15	7422	15	7628	16	7834	16	8040	
					5	3674	5	3782	5	3782	5	3890	5	3998	5	4106	5	4214	
					58	3604	60	3710	60	3710	61	3816	63	3922	65	4028	66	4134	
					5	4729	5	4868	5	4868	5	5008	5	5147	5	5286	5	5425	
					318796		328173		328173		328173		337519		346926		356302		365677
					52	29503	60	30376	60	30376	60	30376	63	32112	65	32930	66	33748	
					1243	95501	1284	92413	1284	92413	1321	101224	1358	104235	1355	106656	1355	106656	
					613	29277	631	30133	631	30133	650	30999	658	31865	666	32731	674	33597	
					241	23848	248	24550	248	24550	255	25251	262	25952	269	26654	276	27355	
					225	23369	231	24056	231	24056	238	24744	244	25431	251	26119	258	26807	
					69	30344	71	31235	71	31235	74	32129	76	33021	78	33914	80	34806	
					111	2338	114	2407	114	2407	118	2476	121	2544	124	2613	127	2682	
					234234		241175		241175		248066		254955		261844		268733		275622
					93	56336	95	63802	95	63802	93	70557	101	72724	103	74599	103	74599	
					100	41402	102	42620	102	42620	105	43337	109	45055	111	45773	114	47111	
					51	22387	52	23045	52	23045	54	23704	55	24363	57	25021	59	25679	
					37		33		33		33		40		41		42		
					21	7107	21	7316	21	7316	22	7525	23	7734	23	7943	24	8152	
					5422		3751		3751		3040		3028		3016		3004		3004
					3537		3518		3518		3093		3079		3065		3051		3051
					4727		4363		4363		5058		5149		5239		5329		5329
					2951		2935		2935		3074		3122		3206		3286		3286
					9549		9330		9330		10111		10392		10672		10952		10952
					24813		25543		25543		26273		27003		27733		28463		28463
					13804		14210		14210		14516		15022		15428		15834		15834
					6760		9017		9017		9275		9532		9790		10048		10048
					5750		5919		5919		6088		6258		6427		6597		6597
					4347		4475		4475		4603		4731		4859		4987		4987
					7010		7216		7216		7422		7628		7834		8040		8040
					3674		3782		3782		3890		3998		4106		4214		4214
					3604		3710		3710		3816		3922		4028		4134		4134
					4729		4868		4868		5008		5147		5286		5425		5425
					318796		328173		328173		337519		346926		356302		365677		365677

APPENDIX B

PLASTIC MEDIA MANUFACTURERS LITERATURE

TABLE OF CONTENTS

	<u>Page</u>
● U.S. Technology Corp.	B-1
● Aerolyte Systems	B-6
● Turco Products, Inc.	B-15
● E.I. Du Pont de Nemours & Co. (Inc.)	B-19
● MPC Industries	B-35



## POLYEXTRA

When operation involves any kind of surface conditioning, treatment, or removal, you should consider the advantages of US DRY STRIPPING MEDIA. It is fast, efficient, and environmentally safe.

Made from a plastic synthetic, the individual particles are irregular in configuration with granular surfaces that incorporate sharp angular edges. When applied, an extremely effective cutting, shearing, and lifting action results. Due to the media's unique physical characteristics it removes buildup without etching, marring, or otherwise damaging most substrates, thus preserving vital surface integrity.

US DRY STRIPPING MEDIA has three different aggression/performance options. With these three distinct formulations—POLYEXTRA, POLYPLUS, and TYPE III—you can select the one best suited to your application needs.

POLYEXTRA, POLYPLUS, and TYPE III are available in two sizing categories: ELECTRONIC GRADE and INDUSTRIAL GRADE. This provides for a choice of either closely sized media for fine detail applications or a broader, more economical sizing distribution for uses where consumption rates are important factors.

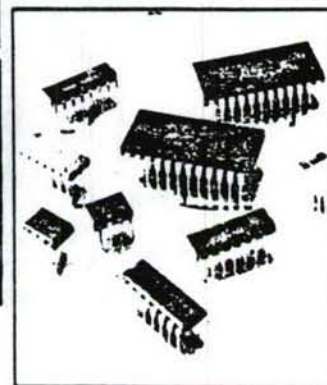

POLYEXTRA is uniform from application to application in contrast to agricultural media, for instance, that often varies in consistency from one lot to another. The media is consistent, constant, and reusable.

## SAVINGS

Cost • Process • Storage • Inspection

# POLYEXTRA

## APPLICATIONS

**Encapsulated electronic components** Will not damage delicate parts or mar surfaces. Leaves product surface clean and dust free, ready for identification printing and soldering.

**Plastic molded parts** Effectively removes flash from parting lines. Removes surface anomalies without damage to the part.

**Clear epoxy optical sensors** Only media able to remove resin bleed without opaquing surface. Eliminates individual masking requirements.

**Aircraft paint removal** Removes most types of paint while leaving anodized and alodined surfaces completely intact.

**Lead frames** Prepares leads for easier and more uniform tinning and coating procedures. Removes flash and resin bleed without impinging surface.

**General deburring** Removes light surface burrs from many materials without causing surface distortion.

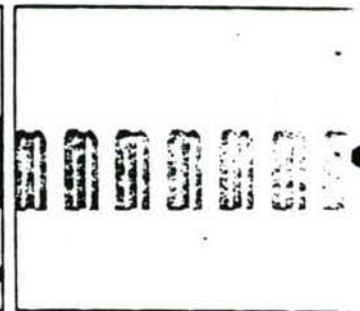

On a Moh's scale of comparative aggression that is equal to

3.0

Agricultural

POLYEXTRA

2.5-3.5

US MEDIA files the world's most effective

BLAST MEDIA PROPERTIES CHART

MEDIA

PROPERTY	POLYEXTRA	POLYPLUS	TYPE III	WALNUT SHELL	GLASS BEADS
Density (gms/cc)	1.15	1.5	1.5	1.3	2.5
Hardness (Moh)	3-	3.5	4	3	5.5
Impact Strength Scale (1 to 10)	4+	6	7+	4	2
Moisture Content	< 0.1%	< 0.1%	< 0.1%	10% (Variable)	0%
Water Absorption (24 hrs. 25°C)	0.13%	0.5%	0.25%	100%	0%
Explosibility Index	5	.2	< .2	10	0
Ignition Temp. (°C)	440	530	> 530	430	N.A.
Min. Explosive Conc. (oz./ft <sup>3</sup> )	.045	.085	.09	.040	N.A.
Chemical Nature	Inert	Inert	Inert	Degradeable	Inert

NOTES: Hardness (Moh Scale): Talc = 1 Diamond = 10  
 Impact Strength: Relative scale of comparison with 10 being strongest and 1 the most friable.  
 N.A.: Not Applicable



**TECHNOLOGY CORPORATION**  
 A Subsidiary of U.S. Plastic and Chemical Corporation

as an efficient, cost-effective replacement for chemical stripping operations and makes a superb paint remover. It can reduce, if not totally eliminate, chemical consumption.



can be realized by eliminating the need to purchase expensive replacement parts.

# POLYPLUS®

## APPLICATIONS

**Aircraft fuselage** Removes surface coatings and buildup without damage to substrate. Can be successfully used on aluminum, titanium, magnesium, steel, and various composites.

**Aircraft components** Can be employed on wide variety of off aircraft components—realizing 8:1 to 12:1 savings ratios over chemicals.

**Composite structures** Strips paint and surface coatings from fiberglass, carbon-graphite, honeycomb, and kevlar substrates without causing fiber bloom or lifting.

**Vehicle bodies** Paint is readily removed from auto, truck, railcar, and bus bodies. Glass, rubber, and chrome surfaces do not have to be masked.

**Die casting** Removes flash from cast components without affecting critical surface dimensions.

**Burr removal** Removes light burrs from components while maintaining integrity of finished part.

## BENEFITS

**Time savings** Substantial savings in time can be realized, especially in comparison to chemical stripping. Average of 90% on components.

**Labor savings** Due to the inherent efficiency of the dry stripping process, full scale utilization of the system can reduce man hours significantly in comparison to existing mechanical and chemical procedures.

# TYPE III®

## APPLICATIONS

**Mold cleaning** Readily cleans molds without affecting surface dimensions. Edges are not radiused, thus mold life is prolonged.

**Surface sealants** Tenacious sealants and adhesives can be safely removed without damage to the substrate.

**Paint removal** Can be substituted for chemical stripping. In many applications, 10:1 time savings can be realized.

**Nuclear decontamination** Surface contamination can be removed without causing wear to tools and parts. Cleaning and disposal costs can be dramatically reduced.

**Engine components** Grease and carbon deposits can be easily dry stripped with no wear to critical mechanical dimensions.

**Chemical hazard reduction** Eliminates dangerous chemical fumes, reduces toxic consumption, eases disposal problems. It is clean and reusable.

**Positive environmental impact** Used properly, the media can reduce/eliminate air, chemical, and water contamination; addressing EPA concerns.

where US MEDIA lies in relation to several other common abrasives.



## PHYSICAL CHARACTERISTICS

	POLYEXTRA	POLYPLUS	TYPE III
Hardness (Moh scale)	3.0	3.5	4.0
Specific Gravity (gms/cc)	1.15	1.50	1.50
Bulk Density (lbs/cu. ft.)	45-48	58-60	58-60
Operational Temp.	0°-250°	0°-300°	0°-350°
Chemical Nature	inert	inert	inert

## PACKAGING

POLYEXTRA	POLYPLUS	TYPE III
50 lb. bags	50 lb. bags	50 lb. bags
200 lb. drums	250 lb. drums	250 lb. drums

## ORDERING INSTRUCTIONS

- (A) Designate product either:  
POLYEXTRA, POLYPLUS, TYPE III
- (B) Specify screen (sieve) size for each product ordered
- (C) Specify quantity ordered for each product  
either in bags or drums

## SPECIFICATIONS

POLYEXTRA, POLYPLUS, TYPE III are now available  
in two sizing categories:

**Electronic Grade** Where tight media sizing is  
crucial for close tolerance applications, requiring  
careful gradation and particle separation.

**Industrial Grade** Where enhanced media  
utilization and cost savings are provided through  
more efficient and effective ranges of sizing distri-  
bution. **Recommended for most applications.**

Inches	Electronic Grade	Industrial Grade	
	Screen Sizes	Screen Sizes	Inches
(.060-.050)	12-16	12-20	(.066-.035)
(.053-.035)	16-20		
(.038-.021)	20-30	20-40	(.038-.015)
(.023-.015)	30-40		
(.016-.009)	40-60	40-60	(.016-.009)
(.010-.005)	60-80	60-80	(.010-.005)

Polyextra®, Polyplus® and Type III® are Registered Trademarks of  
U.S. Technology Corporation



U.S. Technology Corporation  
328 Kennedy Drive  
Putnam, Connecticut 06260  
Telephone 203-928-2707  
Toll Free 800-243-1842

Material is manufactured to  
comply with published specifications  
concerning mesh size, specific gravity,  
shape, hardness, moisture content,  
storage stability, and operating  
temperature range.

Responsibility is disclaimed in  
the handling, use and storage of  
this material since it is beyond the  
scope of our control.

## PLASTIC MEDIA SPECIFICATION SHEET 3.0 MOHS HARDNESS SCALE

AEROLYTE plastic media is composed of synthetic particles which are closely controlled during the production process for both accurate size and aggressive characteristics to meet specific surface requirements. AEROLYTE media is superior to other conventionally used surface preparation media in several important ways.

- Superior hardness consistency
- Superior size consistency
- Manufactured to highest quality standards

Additional key factors in considering AEROLYTE plastic medias are:

- Minimal dust
- No silicosis factor
- Low physical breakdown during use, thus longer life
- Reduced machine wear due to low operating pressure
- Infinite shelf life
- Non hydroscopic

### SPECIFICATIONS

PHYSICAL DESCRIPTION:	Inert, cured polymer resin particles	
APPEARANCE:	Angular particles, white in color	
SPECIFIC GRAVITY:	1.05	
HARDNESS:	3.0 (MOHS Scale)	
BULK DENSITY:	40-45 lb./cu.ft. (based on mesh size)	
AVAILABLE SIZE RANGE:	U.S. Std. Mesh	Inches
	12 - 16	.066 - .046
	16 - 20	.045 - .034
	20 - 30	.033 - .024
	30 - 40	.023 - .017
	40 - 60	.016 - .010
PACKAGING:	50 lb. Cardboard Carton 250 lb. Fiber Drum	
CHEMICAL NAME:	Cured Polymer Resin	
CHEMICAL FAMILY:	Condensation Polymers	
HAZARDOUS COMPONENTS:	(TLV Units) No TLV has been established for any component of this material	
PHYSICAL DATA:	0% Volatile by volume	
REACTIVITY:	No change in reactivity due to accidental contact with other materials.	

2/27/86

JANUARY 1984

**MATERIAL SAFETY DATA SHEET**

SECTION I IDENTIFICATION OF PRODUCT	
MANUFACTURER	SELECT-TECH INC. <span style="float: right;">EMERGENCY PHONE NO. (914) 581-0019</span>
ADDRESS	P.O. BOX 2250, NEWBURGH, N.Y. 12550
TRADE NAME	AEROLYTE PLASTIC MEDIA (3.0 MOHS)
CHEMICAL NAME	CURED POLYMER RESIN
CHEMICAL FAMILY	

SECTION II HAZARDOUS COMPONENTS		
COMPONENTS	%	TLV (UNITS)
NO TLV HAS BEEN ESTABLISHED FOR ANY COMPONENT OF THIS MATERIAL		

SECTION III PHYSICAL DATA			
APPEARANCE & ODOR	GRANULAR SOLID		
BOILING POINT (°F)	NOT APPLICABLE	SPECIFIC GRAVITY WATER = 1	1.05
VAPOR PRESSURE MM. OF HG.	NOT APPLICABLE	% VOLATILE BY VOLUME	< 0.1%
VAPOR DENSITY AIR = 1	NOT APPLICABLE	EVAPORATION RATE BUTYL ACETATE = 1	NOT APPLICABLE
SOLUBILITY IN WATER	NOT APPLICABLE	EVAPORATION RATE ETHYL ETHER = 1	NOT APPLICABLE

SECTION IV FIRE AND EXPLOSION HAZARD DATA			
FLASH POINT (°F)	515	FLAMMABLE LIMITS % BY VOLUME	LOWER UPPER NOT APPLICABLE
FIRE EXTINGUISHING MEDIA	WATER OR CLASS A		
SPECIAL FIRE-FIGHTING PROCEDURES	MATERIAL DURING BURING WILL GIVE OFF ATTOXIC FUMES. FIREFIGHTERS SHOULD WEAR SELF-CONTAINED BREATHING APPARATUS		
UNUSUAL FIRE HAZARDS	NONE, MAINTAIN GOOD HOUSEKEEPING FOR CONTROL OF DUST.		

SECTION V HEALTH HAZARD DATA	
THRESHOLD LIMIT VALUE	SEE SECTION II
EFFECT OF OVEREXPOSURE	DUST INHALATION MAY CAUSE IRRITATION
EMERGENCY AND FIRST AID PROCEDURES	IN CASE OF IRRITATION OF EYES FLUSH WITH WATER, IRRITATION OF RESPIRATORY TRACT, REMOVE FROM EXPOSURE.

SECTION VI REACTIVITY DATA		
STABILITY	UNSTABLE	CONDITIONS TO AVOID
	STABLE X	
INCOMPATIBILITY	NO CHANGE IN REACTIVITY DUE TO ACCIDENTAL CONTACT WITH OTHER MATERIALS.	
HAZARDOUS DECOMPOSITION PRODUCTS	CARBON MONOXIDE, CARBON DIOXIDE, HYDRO CARBON, HYDROGENCYANIDE. ABOVE 500° F.	
HAZARDOUS POLYMERIZATION	MAY OCCUR	CONDITIONS TO AVOID
	WILL NOT OCCUR X	

SECTION VII SPILL OR LEAK PROCEDURES	
STEPS TO BE TAKEN IN CASE MATERIAL IS RELEASED OR SPILLED	SWEEP UP AND PLACE IN A WASTE DISPOSAL CONTAINER
WASTE DISPOSAL METHOD	DISPOSE IN ACCORDANCE WITH LOCAL REGULATION. MATERIAL IS CONSIDERED A NON HAZARDOUS WASTE.

SECTION VIII SPECIAL PROTECTION INFORMATION			
RESPIRATORY PROTECTION	THE NEED FOR RESPIRATORY PROTECTION SHOULD BE DETERMINED BY AN INDUSTRIAL HYGIENE EVALUATION.		
VENTILATION	LOCAL EXHAUST	PREFERABLE	SPECIAL NONE
	MECHANICAL	YES	OTHER NONE
PROTECTIVE GLOVES	NOT REQUIRED	EYE PROTECTION	SAFETY GLASSES
OTHER PROTECTIVE EQUIPMENT	NONE		

SECTION IX SPECIAL PRECAUTIONS	
PRECAUTIONS/HANDLING/STORING	NONE
OTHER PRECAUTIONS	NONE

THIS INFORMATION IS GIVEN WITHOUT A WARRANTY OR REPRESENTATION. WE DO NOT ASSUME ANY LEGAL RESPONSIBILITY FOR SAME. IT IS OFFERED SOLEY FOR YOUR CONSIDERATION. INVESTIGATION AND VERIFICATION. BEFORE USING ANY PRODUCT READ ITS LABEL.

## PLASTIC MEDIA SPECIFICATION SHEET 3.5 MOHS HARDNESS SCALE

AEROLYTE plastic media is composed of synthetic particles which are closely controlled during the production process for both accurate size and aggressive characteristics to meet specific surface requirements. AEROLYTE media is superior to other conventionally used surface preparation media in several important ways.

- Superior hardness consistency
- Superior size consistency
- Manufactured to highest quality standards

Additional key factors in considering AEROLYTE plastic medias are:

- Minimal dust
- No silicosis factor
- Low physical breakdown during use, thus longer life
- Reduced machine wear due to low operating pressure
- Infinite shelf life
- Non hydroscopic

### SPECIFICATIONS

PHYSICAL DESCRIPTION:	Inert, cured polymer resin particles, non combustible	
APPEARANCE:	Angular particles, gray in color	
SPECIFIC GRAVITY:	1.4	
HARDNESS:	3.5 (MOHS Scale)	
BULK DENSITY:	50-55 lb./cu. ft. (based on mesh size)	
AVAILABLE SIZE RANGE:	U.S. Std. Mesh	Inches
	12 - 16	.066 - .046
	16 - 20	.045 - .034
	20 - 30	.033 - .024
	30 - 40	.023 - .017
	40 - 60	.016 - .010
PACKAGING:	50 lb. Cardboard Carton 250 lb. Fiber Drum	
CHEMICAL NAME:	Cured Polymer Resin	
CHEMICAL FAMILY:	Condensation Polymers	
HAZARDOUS COMPONENTS:	(TLV Units) No. TLV has been established for any component of this material	
PHYSICAL DATA:	0% Volatile by volume	
REACTIVITY:	No change in reactivity due to accidental contact with other materials.	

JANUARY 1984

## MATERIAL SAFETY DATA SHEET

SECTION I		IDENTIFICATION OF PRODUCT
MANUFACTURER	SELECT-TECH INC.	EMERGENCY PHONE NO. (914) 561-0019
ADDRESS	P.O. BOX 2250, NEWBURGH, N.Y. 12550	
TRADE NAME	AEROLYTE PLASTIC MEDIA (3.5 MOHS)	
CHEMICAL NAME	CURED POLYMER RESIN	
CHEMICAL FAMILY	CONDENSATION POLYMERS	

SECTION II			HAZARDOUS COMPONENTS
COMPONENTS	%	TLV (UNITS)	
NO TLV HAS BEEN ESTABLISHED FOR ANY COMPONENT OF THIS MATERIAL			

SECTION III		PHYSICAL DATA
APPEARANCE & ODOR	GRANULAR SOLID, AMMONIA ODOR	
BOILING POINT (°F)	NOT APPLICABLE	SPECIFIC GRAVITY WATER = 1 1.25 TO 1.35
VAPOR PRESSURE MM. OF HG.	NOT APPLICABLE	% VOLATILE BY VOLUME 0
VAPOR DENSITY AIR = 1	NOT APPLICABLE	EVAPORATION RATE BUTYL ACETATE = 1 NOT APPLICABLE
SOLUBILITY IN WATER	NOT APPLICABLE	EVAPORATION RATE ETHYL ETHER = 1 NOT APPLICABLE

SECTION IV			FIRE AND EXPLOSION HAZARD DATA
FLASH POINT (°F)	NOT APPLICABLE	FLAMMABLE LIMITS % BY VOLUME	LOWER UPPER NOT APPLICABLE
FIRE EXTINGUISHING MEDIA	CO <sub>2</sub> , DRY CHEMICAL, OR WATER		
SPECIAL FIRE-FIGHTING PROCEDURES	DO NOT USE HIGH PRESSURE WATER STREAM. AIR-BORNE DUST OF ANY NATURE MAY CREATE AN EXPLOSION HAZARD.		
UNUSUAL FIRE HAZARDS	NONE, MAINTAIN GOOD HOUSEKEEPING FOR CONTROL OF DUST.		

<b>SECTION V</b>		<b>HEALTH HAZARD DATA</b>	
THRESHOLD LIMIT VALUE	SEE SECTION II		
EFFECT OF OVEREXPOSURE	DUST INHALATION MAY CAUSE IRRITATION		
EMERGENCY AND FIRST AID PROCEDURES	IN CASE OF IRRITATION OF EYES FLUSH WITH WATER, IRRITATION OF RESPIRATORY TRACT, REMOVE FROM EXPOSURE.		

<b>SECTION VI</b>		<b>REACTIVITY DATA</b>	
STABILITY	UNSTABLE	CONDITIONS TO AVOID	
	STABLE	X	
INCOMPATIBILITY	NO CHANGE IN REACTIVITY DUE TO ACCIDENTAL CONTACT WITH OTHER MATERIALS.		
HAZARDOUS DECOMPOSITION PRODUCTS	CARBON MONOXIDE, CARBON DIOXIDE		
HAZARDOUS POLYMERIZATION	MAY OCCUR	CONDITIONS TO AVOID	
	WILL NOT OCCUR	X	

<b>SECTION VII</b>		<b>SPILL OR LEAK PROCEDURES</b>	
STEPS TO BE TAKEN IN CASE MATERIAL IS RELEASED OR SPILLED			
SWEEP UP AND PLACE IN A WASTE DISPOSAL CONTAINER			
WASTE DISPOSAL METHOD		DISPOSE IN ACCORDANCE WITH LOCAL REGULATION.	

<b>SECTION VIII</b>		<b>SPECIAL PROTECTION INFORMATION</b>	
RESPIRATORY PROTECTION	THE NEED FOR RESPIRATORY PROTECTION SHOULD BE DETERMINED BY AN INDUSTRIAL HYGIENE EVALUATION.		
VENTILATION	LOCAL EXHAUST	PREFFERABLE	SPECIAL NONE
	MECHANICAL	YES	OTHER NONE
PROTECTIVE GLOVES	NOT REQUIRED	EYE PROTECTION	SAFETY GLASSES
OTHER PROTECTIVE EQUIPMENT	NONE		

<b>SECTION IX</b>		<b>SPECIAL PRECAUTIONS</b>	
PRECAUTIONS/HANDLING/STORING	NONE		
OTHER PRECAUTIONS	NONE		

THIS INFORMATION IS GIVEN WITHOUT A WARRANTY OR REPRESENTATION. WE DO NOT ASSUME ANY LEGAL RESPONSIBILITY FOR SAME, IT IS OFFERED SOLEY FOR YOUR CONSIDERATION, INVESTIGATION AND VERIFICATION. BEFORE USING ANY PRODUCT READ ITS LABEL.

## PLASTIC MEDIA SPECIFICATION SHEET 4.0 MOHS HARDNESS SCALE

AEROLYTE plastic media is composed of synthetic particles which are closely controlled during the production process for both accurate size and aggressive characteristics to meet specific surface requirements. AEROLYTE media is superior to other conventionally used surface preparation media in several important ways.

- Superior hardness consistency
- Superior size consistency
- Manufactured to highest quality standards

Additional key factors in considering AEROLYTE plastic medias are:

- Minimal dust
- No silicosis factor
- Low physical breakdown during use, thus longer life
- Reduced machine wear due to low operating pressure
- Infinite shelf life
- Non hydroscopic

### SPECIFICATIONS

PHYSICAL DESCRIPTION:	Inert, cured polymer resin particles, non combustible	
APPEARANCE:	Angular particles, off-white in color	
SPECIFIC GRAVITY:	1.45	
HARDNESS:	4.0 (MOHS Scale)	
BULK DENSITY:	50-55 lb./cu.ft. (based on mesh size)	
AVAILABLE SIZE RANGE:	U.S. Std. Mesh	Inches
	12 - 16	.066 - .046
	16 - 20	.045 - .034
	20 - 30	.033 - .024
	30 - 40	.023 - .017
	40 - 60	.016 - .010
PACKAGING:	50 lb. Cardboard Carton 250 lb. Fiber Drum	
CHEMICAL NAME:	Cured Polymer Resin	
CHEMICAL FAMILY:	Condensation Polymers	
HAZARDOUS COMPONENTS:	(TLV Units) No TLV has been established for any component of this material	
PHYSICAL DATA:	0% Volatile by volume	
REACTIVITY:	No change in reactivity due to accidental contact with other materials.	

2/21/80

## MATERIAL SAFETY DATA SHEET

SECTION I IDENTIFICATION OF PRODUCT	
MANUFACTURER	SELECT-TECH INC. <span style="float: right;">EMERGENCY PHONE NO. (914) 561-0019</span>
ADDRESS	P.O. BOX 2250, NEWBURGH, N.Y. 12550
TRADE NAME	AEROLYTE PLASTIC MEDIA (4.0 MOHS)
CHEMICAL NAME	CURED POLYMER RESIN
CHEMICAL FAMILY	CONDENSATION POLYMERS

SECTION II HAZARDOUS COMPONENTS		
COMPONENTS	%	TLV (UNITS)
NO TLV HAS BEEN ESTABLISHED FOR ANY COMPONENT OF THIS MATERIAL		

SECTION III PHYSICAL DATA			
APPEARANCE & ODOR	GRANULAR SOLID		
BOILING POINT (°F)	NOT APPLICABLE	SPECIFIC GRAVITY WATER = 1	1.40 TO 1.55
VAPOR PRESSURE MM. OF HG.	NOT APPLICABLE	% VOLATILE BY VOLUME	0
VAPOR DENSITY AIR = 1	NOT APPLICABLE	EVAPORATION RATE BUTYL ACETATE = 1	NOT APPLICABLE
SOLUBILITY IN WATER	NOT APPLICABLE	EVAPORATION RATE ETHYL ETHER = 1	NOT APPLICABLE

SECTION IV FIRE AND EXPLOSION HAZARD DATA			
FLASH POINT (°F)	NOT APPLICABLE	FLAMMABLE LIMITS % BY VOLUME	LOWER UPPER NOT APPLICABLE
FIRE EXTINGUISHING MEDIA	CO <sub>2</sub> , DRY CHEMICAL, OR WATER		
SPECIAL FIRE-FIGHTING PROCEDURES	DO NOT USE HIGH PRESSURE WATER STREAM. AIR-BORNE DUST OF ANY NATURE MAY CREATE AN EXPLOSION HAZARD.		
UNUSUAL FIRE HAZARDS	NONE, MAINTAIN GOOD HOUSEKEEPING FOR CONTROL OF DUST.		

SECTION V		HEALTH HAZARD DATA	
THRESHOLD LIMIT VALUE	SEE SECTION II		
EFFECT OF OVEREXPOSURE	DUST INHALATION MAY CAUSE IRRITATION		
EMERGENCY AND FIRST AID PROCEDURES	IN CASE OF IRRITATION OF EYES FLUSH WITH WATER, IRRITATION OF RESPIRATORY TRACT, REMOVE FROM EXPOSURE.		

SECTION VI		REACTIVITY DATA	
STABILITY	UNSTABLE		CONDITIONS TO AVOID
	STABLE	X	
INCOMPATIBILITY	NO CHANGE IN REACTIVITY DUE TO ACCIDENTAL CONTACT WITH OTHER MATERIALS.		
HAZARDOUS DECOMPOSITION PRODUCTS	CARBON MONOXIDE, CARBON DIOXIDE		
HAZARDOUS POLYMERIZATION	MAY OCCUR		CONDITIONS TO AVOID
	WILL NOT OCCUR	X	

SECTION VII		SPILL OR LEAK PROCEDURES	
STEPS TO BE TAKEN IN CASE MATERIAL IS RELEASED OR SPILLED			
SWEEP UP AND PLACE IN A WASTE DISPOSAL CONTAINER			
WASTE DISPOSAL METHOD		DISPOSE IN ACCORDANCE WITH LOCAL REGULATION.	

SECTION VIII		SPECIAL PROTECTION INFORMATION	
RESPIRATORY PROTECTION	THE NEED FOR RESPIRATORY PROTECTION SHOULD BE DETERMINED BY AN INDUSTRIAL HYGIENE EVALUATION.		
VENTILATION	LOCAL EXHAUST	PREFFERABLE	SPECIAL NONE
	MECHANICAL	YES	OTHER NONE
PROTECTIVE GLOVES	NOT REQUIRED	EYE PROTECTION	SAFETY GLASSES
OTHER PROTECTIVE EQUIPMENT	NONE		

SECTION IX		SPECIAL PRECAUTIONS	
PRECAUTIONS/HANDLING/STORING	NONE		
OTHER PRECAUTIONS	NONE		

THIS INFORMATION IS GIVEN WITHOUT A WARRANTY OR REPRESENTATION. WE DO NOT ASSUME ANY LEGAL RESPONSIBILITY FOR SAME, IT IS OFFERED SOLEY FOR YOUR CONSIDERATION, INVESTIGATION AND VERIFICATION. BEFORE USING ANY PRODUCT READ ITS LABEL.



**TECHNICAL**

**DATA**

**PENNWALT**

**BULLETIN**

**NO. 184C**

TURCO PRODUCTS, INC. • 7300 BOLSA AVENUE, WESTMINSTER, CALIFORNIA 92684-3600 • 714/890-3600

**TURCO<sup>®</sup> BLAST MEDIA**  
**Plastic Media Blasting Resins**

**DESCRIPTION:**

TURCO<sup>®</sup> BLAST MEDIA, plastic synthetic resins, are specifically designed for use in air blasting removal of paints, coatings, carbon and residues from aircraft, engines, ground equipment, buses, trucks, etc. It is noncorrosive to all metals.

The product is readily available in 3.5 MOHS hardness and various U. S. standard mesh sizes.

16/20

20/30

30/40

**FEATURES:**

TURCO BLAST MEDIA offer these features:

1. Nonhazardous. No. T.L.V. by U.S. Department of Labor has been established for this material.
2. Manufactured to stringent hardness, size, composition and cleanliness.
3. Nonvolatile, nonhygroscopic.
4. Inert, stable, no change in reactivity due to accidental contact with other materials.
5. Can be used with any pellet blast or glove booth soft grit equipment.
6. Nonflammable. Ignition Temperature - Above 390°C. (735°F.)
7. Unlimited shelf life.
8. Multiple reuse in conjunction with recovery and reclamation systems.
9. Minimal dust during operation.
10. Low physical breakdown during use, thus longer life.
11. Contain no heavy metals.

**USE INSTRUCTIONS:**

Use with any soft grit blasting cabinets or special pellet blasting equipment.

**DISPOSAL INFORMATION:**

Dispose of spent product per local, state and regional regulations. Refer to your local **Turco Territory Manager, Region Sales Office or TURCO MATERIAL SAFETY DATA SHEET** for additional disposal information.

**CAUTION:**

Avoid contact with eyes, skin and clothing. Avoid breathing dust. Do not take internally. Use with adequate (equivalent to outdoor) ventilation.

Protective clothing, such as a face hood and goggles, gloves, boots and suit, should be worn when using this product in other than Glove Booths.

Before using this product refer to container label and **TURCO MATERIAL SAFETY DATA SHEET** for additional precautionary, handling and first aid information.

**NOTICE:**

The above information and recommendations concerning this product are based upon our laboratory tests and field use experience. However, since conditions of actual use are beyond our control, any recommendations or suggestions are made without warranty, express or implied. Manufacturer's and Seller's sole obligation shall be to replace that portion of the product shown to be defective. Neither shall be liable for any loss, damage, or injury, direct or consequential, arising out of the use of this product.



**TURCO PRODUCTS, INC.**  
**MATERIAL SAFETY DATA SHEET**



**SECTION I — PRODUCT NAME:** Turco Blast Media - 3.5 Mohs

Manufacturer's Name:	TURCO PRODUCTS, INC.
Address:	7300 BOLSA AVE., WESTMINSTER, CA 92684-3600
Emergency Telephone No.:	(614) 387-6200 Info. Tel. No. (714) 890-3600

**SECTION II — HAZARDOUS INFORMATION:**

COMPONENTS	C.A.S. Number	CERCLA RQ SPILL lbs.	RCRA Waste No.	ACGIH TLV	OSHA TWA	% WT
No TLV has been established for any components of this product						
CARCINOGENS (As defined in 29CFR 1910-1200)		NTP	IARC	OSHA		
None	-	-	-	-		
PROPER SHIPPING NAME: Turco Blast Media - 3.5 Mohs		HAZARD CLASS: Not Hazardous		HAZARD I.D. No.: -		

**SECTION III — PHYSICAL DATA:**

BOILING POINT, °F:	Not applicable	SPECIFIC GRAVITY:	1.19
VAPOR PRESSURE (mmHg):	Not applicable	VOLATILE, % BY VOL:	Not applicable
VAPOR DENSITY (AIR = 1):	Not applicable	EVAPORATION RATE (Bu. Ac. = 1):	Solid
APPEARANCE AND ODOR: Solid Plastic		SOLUBILITY IN WATER: pH	Insoluble

**SECTION IV — FIRE AND EXPLOSION HAZARDS:**

FLASH POINT AND METHOD USED: Non-flammable. Ignition, estimated 391°C, ASTM D-1929
EXTINGUISHING MEDIA: Foam, carbon dioxide, water, dry chemical
SPECIAL FIRE FIGHTING PROCEDURE AND PRECAUTIONS: Full protective equipment, including self contained breathing apparatus is recommended.
UNUSUAL FIRE AND EXPLOSION HAZARDS: None

**SECTION V — HEALTH, EMERGENCY AND FIRST AID INFORMATION:**

EFFECTS OF OVER EXPOSURE: EYES: or skin: Nuisance particulates may cause irritation. In case of eye contact, flush immediately with large amounts of water for 15 minutes. Call a physician. For skin, wash with soap and water. If irritation persists, consult a physician.
SKIN: See above
INHALATION: Gross overexposure to nuisance particles, regardless of how generated, may cause irritation of the respiratory tract. If irritation develops, remove to fresh air. If breathing difficulty persists, consult a physician.
INGESTION: Ingestion of small quantities of this material under normal circumstances would not cause harmful effect.
MEDICAL CONDITIONS WHICH MAY BE AGGRAVATED:

NO:

FIRST AID: EYES and skin: Nuisance particulates may cause irritation. In case of eye contact, flush immediately with large amounts of water for 15 minutes. Call a physician. For skin, wash with soap and water. If irritation persists, consult a physician.

SKIN: see above

INHALATION: Gross overexposure to nuisance particles, regardless of how generated, may cause irritation of the respiratory tract. If irritation develops, remove to fresh air. If breathing difficulty persists, consult a physician.

INGESTION: Ingestion of small quantities of this material under normal circumstances would not cause harmful effect.

PRIMARY ROUTES OF ENTRY: INHALATION  SKIN CONTACT  OTHER eyes

SECTION VI - REACTIVITY DATE:

STABILITY: STABLE  UNSTABLE \_\_\_\_\_ HAZARDOUS POLYMERIZATION WILL NOT OCCUR

CONDITIONS TO AVOID: Sources of ignition and temperature above 570°F (300°C)

HAZARDOUS DECOMPOSITION PRODUCTS: Hazardous polymerization will not occur.

SECTION VII - SPILL, LEAK AND DISPOSAL PROCEDURE:

SPILL OR RELEASE PROCEDURE: CONCENTRATE:

No special procedures required

USE SOLUTION:

DISPOSAL INFORMATION: CONCENTRATE:

Waste Disposal Method: Sanitary Landfill; in accordance with Federal, State and Local Regulations.

SPENT SOLUTION AND RINSES:

Not Applicable

SECTION VIII - SPECIAL PROTECTION INFORMATION:

RESPIRATORY PROTECTION: Do not breathe dust. Wear a properly fitted dust respirator approved by NIOSH/MSHA during application, unless air monitoring shows air levels below 10 mg/m<sup>3</sup>.

VENTILATION: Provide sufficient ventilation in volume & pattern to keep airborne levels of methyl methacrylate below 100 ppm & dust levels below 10 mg/m<sup>3</sup>.  
PROTECTIVE GLOVES: Leather gloves are recommended.  
EYE PROTECTION: Safety glasses with side shields, goggles, and/or face shield.  
OTHER PROTECTIVE EQUIPMENT: None required, however a protective apron is recommended.

PROTECTIVE EQUIPMENT: CHEMICAL FACE SHIELD OR GOGGLES:  GLOVES  BOOTS  APRON  PROTECTIVE SUIT   
GLOVES, BOOTS, APRON AND SUIT MADE FROM: synthetic or rubber

RECOMMENDED PERSONAL HYGIENE:

Wash with soap and water.

SECTION IX - OTHER INFORMATION:

SPECIAL PRECAUTIONS - HAZARDOUS DECOMPOSITION: Under fire conditions, hazardous decomposition products will include: CO, CO<sub>2</sub>, and smoke. Temperatures above 370°C can cause methyl methacrylate monomer (MMA) to be released. See Section VIII.

	EXPOSURE LIMITS		CAS NUMBER	VAPOR PRESSURE
	OSHA	ACGIH		
Methylmethacrylate	100 ppm	100 ppm	80-62-6	29mm (20°C)

vapor may cause irritation of the eyes, nose & throat. May cause central nervous system effects such as dizziness, headache, nausea and loss of consciousness. Under some circumstances, mutagenic changes have been observed with MMA. The meaning & significance of these results is not understood. At 1000 ppm, MMA is weakly embryotoxic with rats.

MIXING:

Not applicable

REPAIR AND MAINTENANCE OF CONTAMINATED EQUIPMENT:

Not applicable

DATE PREPARED: 9/19/86

DATE REVIEWED:

APPROVED:

G.C. DEPT.

DEPT. 1

SAFETY & ENVIRON.

# Solidstrip™

PLASTIC STRIPPING ABRASIVE

---



**ROBERT B. YOUNG**  
Manager, Dry Stripping Abrasives

E. I. DU PONT DE NEMOURS & COMPANY (INC.)  
Fabricated Products Dept.  
Barley Mill Plaza # 19-2208  
4317 Lancaster Pike  
Wilmington, DE 19805

(302) 992-2638

---

REFER TO APPROPRIATE MATERIAL SAFETY DATA SHEETS FOR TECHNICAL INFORMATION.

---



E. I. DU PONT DE NEMOURS & CO. (INC.)  
F&FP Dept.  
P19-2208  
Wilmington, DE 19896

302/992-2638  
302/772-1932

BACKGROUND

## SOLIDSTRIP PLASTIC ABRASIVES

### BACKGROUND

The plastic bead blasting technology was developed at Hill Air Force Base from 1980-1983 as an alternate method of stripping paint from military aircraft skins and component parts. At the time, phenolic solvents had been banned, and replaced with methylene chloride, acid and orthodichlorobenzene-based strippers. The military was seeking a stripping process which would not pollute environmental water or air, be safe for employees to handle, and not be damaging to the aircraft surfaces or the surrounding facilities. One family of plastic beads was identified which could remove the military paint effectively and without polluting the environment or endangering employees.

Du Pont became interested in supplying plastic beads to this industry in November, 1985. Du Pont produces large quantities of plastic products, and therefore has the material and technical resources to support this business. Du Pont also has experience in marketing products (i.e. composite plastics, paint, fibers, etc.) to the military and commercial aircraft industries.

After extensive laboratory and field testing, we identified two products which effectively remove acrylic and polyurethane paints from metal and composite plastic surfaces. (See technical data and sample sections.) Our Type L product removes paint from substrates with less impact or surface energy than the competitive products of comparable abrasive hardness (Mohs scale) due to its lower density (1.2 versus 1.5g/cc). Recent evidence indicates that the Type L can be utilized over a variety of composites without damaging the parts.

Type C is by far the most aggressive material in our product line (1.8 density and 4.0 Mohs hardness), and is recommended for medium-gauge metals and some very rigid plastic parts.

The benefits of procuring media from Du Pont are as follows:

- o more consistency of media quality
- o more technical perspective on how the products should be used
- o more material stocking points, which should shorten delivery time
- o more secure (captive) raw material sources
- o effective advocacy of the bead blasting process at high levels within the military

We believe in the bead blasting technique, and believe that it has a solid future in military and non-military applications. For additional information, please contact Robert Young at the Du Pont Company on (302) 992-2638.

TECHNICAL DATA

# Solidstrip™

## PLASTIC STRIPPING ABRASIVE

---

### Du Pont Dry Stripping Abrasive Technical Data Sheet

#### TYPE C

Density (g/cc)	1.8
Hardness (Mohs)	>4.0
Moisture Content (%)	<0.3
Ignition Temp. (°C)	390°C
Chemical Nature	Inert

For more information, contact R. B. Young (302) 992-2638 or D. J. Clymer (302) 772-1932.



E. I. DU PONT DE NEMOURS & CO. (INC.)  
F&FP Dept.  
P19-2208  
Wilmington, DE 19898 B-24

302/992-2638  
302/772-1932

# Solidstrip™

PLASTIC STRIPPING ABRASIVE

---

## Du Pont Dry Stripping Abrasive Technical Data Sheet

### TYPE L

Density (g/cc)	1.2
Hardness (Mohs)	3.5
Moisture Content (%)	<0.6
Ignition Temp. (°C)	390°C
Chemical Nature	Inert

For more information, contact R. B. Young (302) 992-2638 or D. J. Clymer (302) 772-1932.



E. I. DU PONT DE NEMOURS & CO. (INC.)  
F&FP Dept.  
P19-2208  
Wilmington, DE 19898

B-25

302/992-2638  
302/772-1932

MATERIAL SAFETY  
DATA SHEETS

MATERIAL SAFETY DATA SHEET

SECTION I

MANUFACTURER:

E. I. du Pont de Nemours & Co., Inc.  
Fabricated Products Dept.  
Wilmington, DE 19898

TELEPHONE:

For Product Information: 800-441-7515  
For Medical Emergencies: 800-441-3637  
For Transportation Emergency: 800-424-9300

PRODUCT: SOLIDSTRIP Type C Plastic Abrasive Media

SECTION II: INGREDIENTS

CHEMICAL NAME: Modified Acrylic Thermoset Resin

Acrylic Resin - Not Hazardous

Inert Fillers - Not Hazardous, Encapsulated in Product

SECTION III: PHYSICAL DATA

EVAPORATION RATE: Solid

VAPOR DENSITY: Not Applicable

SOLUBILITY IN WATER: Insoluble

PERCENT VOLATILE: Not Applicable

APPROXIMATE BOILING RANGE: Not Applicable

DENSITY: 1.78

SECTION IV: FIRE & EXPLOSION DATA

FLASH POINT (METHOD):

APPROX. FLAMMABLE LIMITS: Not applicable

EXTINGUISHING MEDIA: Foam, Carbon Dioxide, Dry Chemical, Water

SPECIAL FIRE FIGHTING PROCEDURES: Full protective equipment, including self-contained breathing apparatus, is recommended.

UNUSUAL FIRE & EXPLOSION HAZARDS: None

SECTION V: HEALTH HAZARD DATA

ROUTE OF ENTRY; SYMPTOMS/EFFECTS OF OVEREXPOSURE AND FIRST AID

INGESTION: Ingestion of small quantities of this material under normal circumstances would not cause harmful effect.

**INHALATION:** Gross overexposure to nuisance particles, regardless of how generated, may cause irritation of the respiratory tract. If irritation develops, remove to fresh air. If breathing difficulty persists, consult a physician.

**SKIN OR EYE CONTACT:** Nuisance particulates may cause irritation. In case of eye contact, flush immediately with large amounts of water for at least 15 minutes. Call a physician. For skin wash with soap and water. If irritation persists, consult a physician.

SECTION VI: REACTIVITY DATA

**STABILITY:** Stable

**CONDITIONS TO AVOID:** Sources of ignition and temperatures above 570°F (300°C)

**INCOMPATIBILITY:** Not applicable

**HAZARDOUS DECOMPOSITION:** Under fire conditions, hazardous decomposition products may include: CO, CO<sub>2</sub> and smoke. Temperatures above 300°C can cause methyl methacrylate monomer<sup>2</sup> (MMA) to be released. See Section VIII.

	EXPOSURE LIMITS		CAS NUMBER	VAPOR PRESSURE
	OSHA	ACGIH		
Methylmethacrylate	100 ppm	100 ppm	80-62-6	29mm (20°C)

Vapor may cause irritation of the eyes, nose and throat. May cause central nervous system effects such as dizziness, headache, nausea and loss of consciousness.

Under some circumstances, mutagenic changes have been observed with MMA. The meaning and significance of these results is not understood. At 1000 ppm, MMA is weakly embryotoxic with rats.

**HAZARDOUS POLYMERIZATION:** Will not occur

**CONDITIONS TO AVOID FOR HAZARDOUS POLYMERIZATION:** Not applicable

SECTION VII: SPILL OR LEAK PROCEDURES

**STEPS TO BE TAKEN IN CASE MATERIAL IS RELEASED OR SPILLED:** No special procedures required.

**WASTE DISPOSAL METHOD:** Sanitary Landfill; in accordance with Federal, State and Local Regulations

SECTION VIII: SPECIAL PROTECTION INFORMATION

**RESPIRATORY:** Do not breathe dust. Wear a properly fitted dust respirator approved by NIOSH/MSHA during application, unless air monitoring shows air levels below 10 mg/m<sup>3</sup>.

VENTILATION: Provide sufficient ventilation in volume and pattern to keep airborne levels of methylmethacrylate below 100 ppm and dust levels below 10 mg/m<sup>3</sup>.

PROTECTIVE GLOVES: Leather gloves are recommended.

EYE PROTECTION: Safety glasses with side shields, goggles, and/or face shield

OTHER PROTECTIVE EQUIPMENT: None required, however, a protective apron is recommended.

SECTION IX - SPECIAL PRECAUTIONS

PRECAUTIONS TO BE TAKEN IN HANDLING AND STORING: Not applicable

OTHER PRECAUTIONS: None

TRANSPORTATION: Not regulated

NOTICE: The data in this material safety data sheet relates only to the specific material designated herein and does not relate to use in combination with any other material or in any process.

---

Technical Services Manager

Date: 9/16/86

MATERIAL SAFETY DATA SHEET

SECTION I

MANUFACTURER:

E. I. du Pont de Nemours & Co., Inc.  
Fabricated Products Dept.  
Wilmington, DE 19898

TELEPHONE:

For Product Information: 800-441-7515  
For Medical Emergencies: 800-441-3637  
For Transportation Emergency: 800-424-9300

PRODUCT: SOLIDSTRIP Type L Plastic Abrasive Media

SECTION II: INGREDIENTS

CHEMICAL NAME: Acrylic Resin

Acrylic Resin - Not Hazardous

SECTION III: PHYSICAL DATA

EVAPORATION RATE: Solid	VAPOR DENSITY: Not Applicable
SOLUBILITY IN WATER: Insoluble	PERCENT VOLATILE: Not Applicable
APPROXIMATE BOILING RANGE: Not applicable	DENSITY: 1.19

SECTION IV: FIRE & EXPLOSION DATA

FLASH POINT (METHOD): Estimated flash ignition approx. 391°C, ASTM D-1929

APPROX. FLAMMABLE LIMITS: Not applicable

EXTINGUISHING MEDIA: Foam, Carbon Dioxide, Water, Dry Chemical

SPECIAL FIRE FIGHTING PROCEDURES: Full protective equipment, including self-contained breathing apparatus, is recommended.

UNUSUAL FIRE & EXPLOSION HAZARDS: None

SECTION V: HEALTH HAZARD DATA

ROUTE OF ENTRY; SYMPTOMS/EFFECTS OF OVEREXPOSURE AND FIRST AID:

INGESTION: Ingestion of small quantities of this material under normal circumstances would not cause harmful effect.

**INHALATION:** Gross overexposure to nuisance particles, regardless of how generated, may cause irritation of the respiratory tract. If irritation develops, remove to fresh air. If breathing difficulty persists, consult a physician.

**SKIN OR EYE CONTACT:** Nuisance particulates may cause irritation. In case of eye contact, flush immediately with large amounts of water for 15 minutes. Call a physician. For skin, wash with soap and water. If irritation persists, consult a physician.

SECTION VI: REACTIVITY DATA

**STABILITY:** Stable

**CONDITIONS TO AVOID:** Sources of ignition and temperature above 570°F (300°C)

**INCOMPATIBILITY:** Not applicable

**HAZARDOUS DECOMPOSITION:** Under fire conditions, hazardous decomposition products will include: CO, CO<sub>2</sub> and smoke. Temperatures above 370°C can cause methyl methacrylate monomer (MMA) to be released. See Section VIII.

	EXPOSURE LIMITS		CAS NUMBER	VAPOR PRESSURE
	OSHA	ACGIH		
Methymethacrylate	100 ppm	100 ppm	80-62-6	29mm(20°C)

Vapor may cause irritation of the eyes, nose and throat. May cause central nervous system effects such as dizziness, headache, nausea and loss of consciousness.

Under some circumstances, mutagenic changes have been observed with MMA. The meaning and significance of these results is not understood. At 1000 ppm, MMA is weakly embryotoxic with rats.

**HAZARDOUS POLYMERIZATION:** Will not occur.

**CONDITIONS TO AVOID FOR HAZARDOUS POLYMERIZATION:** Not applicable

SECTION VII: SPILL OR LEAK PROCEDURES

**STEPS TO BE TAKEN IN CASE MATERIAL IS RELEASED OR SPILLED:** No special procedures required.

**WASTE DISPOSAL METHOD:** Sanitary Landfill; in accordance with Federal, State and Local Regulations

SECTION VIII: SPECIAL PROTECTION INFORMATION

**RESPIRATORY:** Do not breathe dust. Wear a properly fitted dust respirator approved by NIOSH/MSHA during application, unless air monitoring shows air levels below 10 mg/m<sup>3</sup>.

VENTILATION: Provide sufficient ventilation in volume and pattern to keep airborne levels of methyl methacrylate below 100 ppm and dust levels below 10 mg/m<sup>3</sup>.

PROTECTIVE GLOVES: Leather gloves are recommended.

EYE PROTECTION: Safety glasses with side shields, goggles, and/or face shield.

OTHER PROTECTIVE EQUIPMENT: None required, however, a protective apron is recommended.

SECTION IX - SPECIAL PRECAUTIONS

PRECAUTIONS TO BE TAKEN IN HANDLING AND STORING: Not applicable.

OTHER PRECAUTIONS: None

TRANSPORTATION: Not regulated.

NOTICE: The data in this material safety data sheet relate only to the specific material designated herein and do not relate to use in combination with any other material or in any process.

---

Technical Services Manager

Date: 9/16/86

SAMPLES

B-33

**"SOLIDSTRIP"**  
**PLASTIC MEDIA PRODUCTS**

Type L Media

Type C Media

**CURRENT STOCKPOINTS**

Caber, Inc.	754 S. Chicago Seattle, Washington 98108 (206) 762-1320
Intex Products, Inc.	King Road Greenville, South Carolina 29605 (803) 242-6152
Schmidt Manufacturing, Inc.	11927 S. Hwy. 6 Fresno (Houston), Texas 77545 (800) 231-2085
Turco Products	24700 S. Main St. Carson, California 90749 (213) 518-2350
	State Road 95 West Marion, Ohio 43302 (614) 387-6200
	3300 Montreal Industrial Way Tucker, GA 30084 (404) 939-8332, 33, 34
	Loren Products 250 Canal Street Lawrence, Massachusetts 01840 (617) 685-0911

M P C I N D U S T R I E S  
PATENT PLASTICS, INC.

638 MARYVILLE PIKE. S.W.

P.O. BOX 9246

KNOXVILLE, TENNESSEE 37920

(615) 573-5411

The enclosed brochure presents our Synthetic Plastic Abrasive Blast Media which is used by the Air Force, Army, Coast Guard and other nonmilitary firms to strip coatings and to clean and prepare various substrates for the next operation.

Materials that are equivalent to these are U.S. Technology Type I (Polyextra), Type II (Polyplus) and Type III.

We make these media materials from thermosetting resins we manufacture. Our blast media is uniform, narrow mesh sizes, noncorrosive, and Type II and Type M are nonflammable for open cycle blasting. In addition these media leave no deposit on substrate after blasting, and we are competitive in price.

Would appreciate you looking at these materials for your specific application and operation.

Sincerely,

Matthew F. Callahan  
President

# **SYNTHETIC PLASTIC ABRASIVE BLAST MEDIA**

**For cleaning, deflashing and  
surface preparation.**

- dry stripping of coatings
- leaves no surface contaminants
- non-flammable for open blasting
- low pressure
- low energy consumption
- tough cutting edges
- recyclable
- harmless to chrome glass & rubber
- conditions surface for plating,  
painting, matte finishing and polishing
- uniform mesh size

**MPC INDUSTRIES**  
**638 Maryville Pike, SW**  
**Box 9246**  
**Knoxville, TN 37920**  
**615-573-5411**

Circle 108 on reader information card

# **SYNTHETIC PLASTIC ABRASIVE BLAST MEDIA**

MPC Industries  
Patent Plastics, Inc.  
638 Maryville Pike SW  
P.O. Box 9246  
Knoxville, Tennessee 37920

(615) 573-5411

# SYNTHETIC PLASTIC ABRASIVE BLAST MEDIA

TYPE I - SFC 1412

## Ordering and Payment Address:

MPC Industries  
 Patent Plastics, Inc.  
 638 Maryville Pike SW  
 P.O. Box 9246  
 Knoxville, Tennessee 37920  
 (615) 573-5411

Type I - SFC 1412 is a cleaning and deflashing plastic abrasive used to remove dirt, rust and contaminants from delicate electronic surfaces, aircraft fuselage and molded parts. Type I - SFC 1412 abrasive compound is the least aggressive of the thermosetting resin abrasives and is used where the integrity of the metal and composite surface must be maintained without destroying tolerances.

## ORDERING INFORMATION

Packaging: 50 lb. bags  
 250 lb. Fiber Drum

Minimum Order: 250 lb.  
 Geographic Coverage: 48 Contiguous States and Washington DC  
 Point of Production: Knoxville, Knox County, Tennessee  
 Prompt Payment: 1%, 20 days  
 F.O.B. Point: Knoxville

Electronic Components  
 Molded Parts  
 Paint Removal  
 Deburring

## PRICING

Mesh Size:	12-20	20-30	30-40	40-60
>30,000#	\$2.00	\$2.05	\$2.10	\$2.45
>10,000#	2.02	2.07	2.12	2.60
>5,000#	2.04	2.09	2.14	2.65
>2,000#	2.06	2.11	2.16	2.70
<2,000#	2.08	2.13	2.18	2.75

## PHYSICAL PROPERTIES

Hardness (Mohs)	3.0			
(Rockwell)	E20-50			
Grit Size Mesh*	12 - 20	20 - 30	30 - 40	40 - 60
Specific Gravity	1.2			
Apparent Density	0.60-0.70			
Flammability	Flammable			
Operating Temperature	0-260° F			
Particle Shape	Sharp Irregular Granules			
ph @ Room Temperature	±1 ph Unit distilled H <sub>2</sub> O			
Moisture	Less than 0.05%			
Ignition Temperature	435° C			
Color	Various and Mixed			

\*Other Mesh Sizes Available

**TYPE II - SFC 1734**

Type II - SFC 1734 is more aggressive material than other soft blasting media and manufactured so that its abrasive qualities are consistent and will remove tough contaminants without damage to the substrate. Storage life is unlimited and will resist fungus and rodent attack under any climate conditions. With proper set-up of the blasting operation, surface treating of the substrate is accomplished, with costs savings realized through energy consumption and clean parts ready for the next production operation.

Aircraft Substrates  
Composites  
Vehicle Bodies  
Aircraft Components  
Flash Removal

12-20	20-30	30-40	40-60
\$2.05	\$2.10	\$2.15	\$2.60
2.07	2.12	2.17	2.70
2.09	2.15	2.19	2.80
2.11	2.17	2.21	2.90
2.13	2.19	2.23	3.00

3.5  
E93-98

12-20	20-30	30-40	40-60
-------	-------	-------	-------

1.5  
0.70-0.80  
Non-Flammable, Self Extinguishing  
0-290° F  
Sharp Irregular Granules  
Neutral in distilled H<sub>2</sub>O  
Less than 0.05%  
530° C  
Various and Mixed

**TYPE M - SFC 2026**

With Type M - SFC 2026 one is able to move from the top aggressive level of Type II - SFC 1734 abrasive media to the aggressive area of metal abrasives. Cleaning and surface preparation of metal die castings, gears, engine parts, wires, pretreatment of metal surfaces for plating, and marine equipment are areas of use for this Type M - SFC 2026 media. Type M is used where abrasive grain types are too harsh and damage the working surface and blasting equipment.

Paint-Sealant Removal  
Engine Components  
Nuclear Decontamination  
Mold Cleaning

12-20	20-30	30-40	40-60
\$2.15	\$2.20	\$2.25	\$2.70
2.17	2.22	2.27	2.80
2.19	2.24	2.29	2.90
2.21	2.26	2.31	3.00
2.23	2.28	2.33	3.10

4.0  
E106-111

12-20	20-30	30-40	40-60
-------	-------	-------	-------

1.5  
0.70-0.85  
Non-Flammable, Self Extinguishing  
0-360° F  
Sharp Irregular Granules  
Neutral in distilled H<sub>2</sub>O  
Less than 0.05%  
535° C  
Various and Mixed

This data sheet is prepared for guidance in using MPC Industries, Patent Plastics, Inc., Synthetic Plastic Abrasive Blast Media, and is based on information believed to be reliable, but suitability for any particular use should be confirmed by the user's own test.

Material is manufactured to the physical characteristics stated.

No warranty is expressed or implied regarding its use in performance, since it is beyond the scope of our control.

**MPC Industries  
Patent Plastics, Inc.  
638 Maryville Pike SW  
P.O. Box 9246  
Knoxville, Tennessee 37920  
(615) 573-5411**

**BULK RATE  
U.S. POSTAGE  
PAID  
KNOXVILLE, TN  
PERMIT # 309**

APPENDIX C

ORIGINAL DRAFT SPECIFICATION FOR PLASTIC MEDIA

TABLE OF CONTENTS

	<u>Page</u>
• Original Draft Specifications for Plastic Media (June 1986)	C-1
• Revised Draft Specifications for Plastic Media (June 1987)	C-22

ORIGINAL DRAFT SPECIFICATIONS FOR PLASTIC MEDIA

(June 1986)

DEPARTMENT OF THE NAVY

NAVAL AIR ENGINEERING CENTER

LAKEHURST, N. J. 08733

IN REPLY REFER TO

4121

Ser 9321/38161

6 JAN 1956

From: Commanding Officer, Naval Air Engineering Center

Subj: REQUEST FOR COMMENTS ON PROPOSED MIL-A-XXXXX(AS), ABRASIVE MATERIAL,  
PLASTIC, FOR REMOVAL OF PAINT, ORGANIC COATINGS AND SURFACE CONTAMINANTS

Encl: (1) Copy of proposed subject document

1. Please review enclosure (1) and forward your comments or concurrence. Indicate review, user, or no interest and designate comments as essential or suggested.
2. Provide justification for essential comments. All unjustified comments will be considered as suggested.
3. The Naval Air Systems Command (AS) is preparing activity. Replies should be forwarded to the Commanding Officer, Naval Air Engineering Center, Systems Engineering and Standardization Department (Code 9321HV), Lakehurst, N.J. 08733-5100 by 26 February 1956. Please include the name and telephone number of the individual in your activity to be contacted for clarification of comments in your reply.
4. If further information is needed, contact Mr. H. Vasil, (201) 323-7450 or AUTOVON 024-7450.

*N. Raditz*

N. RADITZ  
By direction

Distribution:  
(see next page)



4121  
Ser 9321/38161

Subj: REQUEST FOR COMMENTS ON PROPOSED MIL-A-XXXXX(AS) ABRASIVE MATERIAL,  
PLASTIC, FOR REMOVAL OF PAINT, ORGANIC COATINGS AND SURFACE CONTAMINENTS

Distribution

Commanding Officer  
Naval Air Rework Facility  
Code 340  
Naval Air Station  
Norfolk, VA 23511

Commanding Officer  
Naval Air Rework Facility  
Code 340  
Marine Corps Air Station  
Cherry Point, NC 28533

Commanding Officer  
Naval Air Rework Facility  
Code 340  
Naval Air Station  
Jacksonville, FL 32212

Commanding Officer  
Naval Air Rework Facility  
Code 340  
Bldg. 604  
Naval Air Station  
Pensacola, FL 32508

Commanding Officer  
Naval Air Rework Facility  
Code 340  
Naval Air Station  
North Island  
San Diego, CA 92135

Commanding Officer  
Naval Air Rework Facility  
Code 340  
Naval Air Station  
Alameda, CA 94501

HQ AFPC/WMH  
Attention: Mr. F. Chuang  
Wright Patterson AFB, OH 45433

Subj: REQUEST FOR COMMENTS ON PROPOSED MIL-A-XXXXX(AS) ABRASIVE MATERIAL  
PLASTIC, FOR REMOVAL OF PAINT, ORGANIC COATINGS AND SURFACE CONTAMINATION

Distribution

HQ AFPC/MAXT  
Attention: Mr. T. Mallets  
Wright Patterson AFB, OH 45433

AFNAL/MLSA  
Attention: Mr. S. Childers  
Wright Patterson AFB, OH 45433

WRALC/MEMC  
Attention: R. Juey  
Warner Robins AFB, GA 31098-5609

CC-ALC/MSRA  
Attention: Mr. Leon Jaeger  
Hill Air Force Base, UT 84056-5609

CC-ALC/SRA KMEAR  
Attention: Mr. R. Clay  
Hill Air Force Base, UT 84056-5609

CC-ALC/MABE  
Attention: Maj Henderson  
Hill Air Force Base, UT 84056

CC-ALC/MIETH  
Attention: Mr. D. Svejkovsky  
Tinker Air Force Base, OK 73145

HQ-AFESC/RDWH  
Attention: 1st Lt. R. Peters  
Tydall Air Force Base, FL 32403

COMNAVAIRPLANT Code 528  
Attention: Mr. G. Browne  
US Naval Air Station  
Norfolk, VA 23511-5188

COMNAVAIRPAC Code 7412  
Commander Naval Air Force  
Attention: Mr. Ray Mason  
US Pacific Fleet  
Box 1210  
US Naval Air Station  
San Diego, CA 92135

Subj: REQUEST FOR COMMENTS ON PROPOSED MIL-A-XXXXX(AS) ABRASIVE MATERIAL,  
PLASTIC, FOR REMOVAL OF PAINT, ORGANIC COATINGS AND SURFACE CONTAMINENTS

Distribution

Commander

Naval Sea Systems Command  
Code-0511 (Mr. H. Bleile)  
Washington, DC 20362-5101

SDSCC-OLC

Corpus Christi Army Depot  
Mail Stop 27 (Mr. John Bullington)  
Corpus Christi, TX 78419

General Services Administration

Attention: Mr. J. Abelas  
Crystal Mall 4, Room 714  
Washington, DC 20406

WRALC/WABEI

Attention: Mr. M. Candiff  
Warner Robbins Air Force Base, GA 31098-5609

OO-ALC/INISRA

Attention: Mr. Leon Jaeger  
Hill Air Force Base, UT 84056-5609

## MILITARY SPECIFICATION

### ABRASIVE MATERIAL, PLASTIC, FOR REMOVAL OF PAINT, ORGANIC COATINGS AND SURFACE CONTAMINANTS

This specification is approved for use within the Naval Air Systems Command, Department of the Navy, and is available for use by all Departments and Agencies of the Department of Defense.

#### 1. SCOPE

1.1 Scope. This specification covers three types of plastic abrasives to be used as soft blasting material to remove surface coatings and contaminants from metal and composite surfaces.

1.2 Classification. The plastic abrasive shall be typed by hardness as follows:

Type I - For soft metals (Rockwell hardness E 20 to E 50)

Type II - General purpose (Rockwell hardness E 93 to E 98)

Type III - For hard aluminum, steel, titanium (Rockwell hardness E 106 to E 111)

1.3 Part Numbers. Part numbering system shall be as indicated below. This number is intended for cataloging and ordering purposes.

MXXXXX	X	XXXX
-----	-----	-----
Specification identifier	Type I - 1 Type II - 2 Type III - 3	Mesh size range (See Table I)

Example. Type I, 16 to 20 mesh size range abrasives shall be ordered as MXXXXX-1-1620.

#### 2. APPLICABLE DOCUMENTS

##### 2.1 Government documents.

Beneficial comments (recommendations, additions, deletions) and any pertinent data which may be of use in improving this document should be addressed to: Systems Engineering and Standardization Department (Code 93), Naval Air Engineering Center, Lakehurst, NJ 08733-5100, by using the self-addressed Standardization Document Improvement Proposal (DD Form 1426) appearing at the end of this document or by letter.

FSC 5350

DISTRIBUTION STATEMENT A. Approved for public release; distribution is unlimited.

2.1.1 Specifications and standards. The following specifications and standards form a part of this specification to the extent specified herein. Unless otherwise specified, the issues of these documents shall be those listed in the issue of the Department of Defense Index of Specifications and Standards (DODISS) and supplement thereto, cited in the solicitation.

## SPECIFICATIONS

## FEDERAL

QQ-A-250/12	-	Aluminum Alloy 7075, Plate and Sheet
RR-S-366	-	Sieves, Standard, for Testing Purposes
UU-S-48	-	Sacks, Shipping Paper
CCC-C-440	-	Cloth, Cheesecloth, Cotton, Bleached and Unbleached
PPP-B-601	-	Box, Wood, Cleated Plywood
PPP-B-621	-	Box, Wood, Nailed and Lock Corner
PPP-D-723	-	Drums, Fiber

## MILITARY

MIL-P-116	-	Preservation, Methods of
MIL-A-9962	-	Abrasive Mats, NonWoven and Nonmetallic
MIL-P-23377	-	Primer Coating, Epoxy Polyamide, Chemical and Solvent Resistant
MIL-B-43666	-	Box, Shipping, Consolidation
MIL-C-81706	-	Chemical Conversion Materials for Coating Aluminum and Aluminum Alloys
MIL-C-83286	-	Coating, Urethane, Aliphatic Isocyanate, For Aerospace Application

## STANDARDS

## MILITARY

MIL-STD-105	-	Sampling Procedures and Tables for Inspection by Attributes
MIL-STD-129	-	Marking for Shipment and Storage
MIL-STD-147	-	Palletized Unit Loads

2.1.2 Other Government documents. The following other Government documents form a part of this specification to the extent specified herein. Unless otherwise specified, the issues shall be those in effect on the date of the solicitation.

## DEPARTMENT OF TRANSPORTATION

- DOT 22A - Wooden Drums, Glued Plywood
- DOT 22B - Wooden Drums, Glued Plywood

(Copies of specifications, standards, handbooks, drawings, and publications and other government documents required by contractors in connection with specific acquisition functions should be obtained from the contracting activity or as directed by the contracting activity.)

2.2 Other publications. The following documents form a part of this specification to the extent specified herein. Unless otherwise specified, the issues of the documents which are DOD adopted shall be those listed in the issue of the DODISS specified in the solicitation. Unless otherwise specified, the issues of documents not listed in the DODISS shall be the issue of the nongovernment documents which is current on the date of the solicitation.

## AMERICAN SOCIETY FOR TESTING AND MATERIALS (ASTM)

- ASTM D229 - Testing Rigid Sheet and Plate Materials Used for Electrical Insulation
- ASTM D256 - Impact Resistance of Plastics and Electrical Insulating Materials
- ASTM D571 - Water Absorption of Plastics
- ASTM D651 - Tensile Strength of Molded Electrical Insulating Materials
- ASTM D785 - Rockwell Hardness of Plastics and Electrical Insulating Materials
- ASTM D3951 - Commercial Packaging
- ASTM E70 - pH of Aqueous Solutions with the Glass Electrode
- ASTM G21 - Determining Resistance of Synthetic Polymeric Materials to Fungi

(Application for copies should be addressed to the American Society for Testing and Materials, 1916 Race Street, Philadelphia, PA 19103.)

(Nongovernment standards and other publications are normally available from the organizations which prepare or which distribute the documents. These documents also may be available in or through libraries or other informational services.)

2.3 Order of precedence. In the event of a conflict between the text of this specification and the references cited herein (except for associated detail specifications, specification sheets or MS standards), the text of this specification shall take precedence. Nothing in this specification, however, shall supersede applicable laws and regulations unless a specific exemption has been obtained.

### 3. REQUIREMENTS

3.1 First article. When specified in the contract or purchase order, a sample of the plastic abrasive material shall be subjected to first article inspection (see 4.3 and 6.3).

3.2 Materials. The plastic abrasives shall be made from virgin, non-halogenated, thermosetting resins. The material shall be infusible, inert and non-filled. The product shall be free from any foreign matter.

3.3 Particle size. The abrasive material shall have particle size distribution as shown in Table I for each mesh size range. Testing shall be by the screen analysis of 4.5.2

3.4 Particle shape. When observed as specified in 4.5.3 the three dimensional characteristics shall be irregular, angular shapes with sharp edges and corners.

3.5 Undersirable particulates. When tested as specified in 4.5.4, the amount of undersirable particulates, in weight percent, shall be no more than the following:

	<u>Light particulates</u>	<u>Heavy particulates</u>
Type I	0.05	0.05
Type II	0.50	0.05
Type III	10.00	0.05

3.6 Physical characteristics. Physical characteristics of the abrasive shall be as specified in Table II.

#### 3.7 Performance requirements.

3.7.1 Cleaning efficiency. Abrasive material shall remove a minimum of 99 percent of the paint system from each test panel without surface distortion or degradation the panel when tested as specified in 4.5.6. ?

3.8 pH. pH determinations of a sample of distilled water, before and after intimate mixing with the abrasive granules shall not vary by  $\pm 1$  pH unit. Testing in accordance with 4.5.6.

3.9 Workmanship. The plastic abrasive material shall be prepared in accordance with the best commercial practice for this material.

#### 4. QUALITY ASSURANCE PROVISIONS

4.1 Responsibility for inspection. Unless otherwise specified in the contract or purchase order, the contractor is responsible for the performance of all inspection requirements as specified herein. Except as otherwise specified in the contract or purchase order, the contractor may use his own or any other facilities suitable for the performance of the inspection requirements specified herein, unless disapproved by the Government. The Government reserves the right to perform any of the inspections set forth in the specification where such inspections are deemed necessary to assure supplies and services conform to prescribed requirements.

4.1.1 Responsibility for compliance. All items must meet all requirements of sections 3 and 5. The inspection set forth in this specification shall become a part of the contractor's overall inspection system or quality program. The absence of any inspection requirements in the specification shall not relieve the contractor of the responsibility of assuring that all products or supplies submitted to the Government for acceptance comply with all requirements of the contract. Sampling in quality conformance does not authorize submission of known defective material, either indicated or actual, nor does it commit the Government to acceptance of defective material.

4.2 Classification of inspections. The inspection requirements specified herein are classified as follows:

- a. First article inspection (see 4.3)
- b. Quality conformance inspection (see 4.4)

4.2.1 Inspection conditions. Unless otherwise specified, all inspections shall be performed in accordance with the test conditions specified in the test method document or the applicable paragraph of this specification.

4.3 First article inspection. First article inspection shall be performed by an activity designated by the contracting officer. The inspection shall consist of all the tests and inspections of this specification.

4.3.1 First article samples. The first article sample shall consist of sufficient test specimens, prepared from the thermosetting resins prior to grinding, to perform the impact strength (4.5.1), elongation (4.5.1) and rockwell hardness (4.5.1) requirements; and 50 pounds (22.7 kilograms) of the plastic abrasive granules produced in the manufacturing facility intended to be used in filling the contract or order. This sample shall be used for the remaining tests. There shall be no failures in any requirement.

#### 4.4 Quality conformance inspection.

4.4.1 Lot formation. A lot shall consist of 2,500 pounds (1150 kilograms) of the same type and mesh range abrasive.

#### 4.4.2 Sampling and inspection.

4.4.2.1 Visual examination. A random sample of abrasive shall be selected from each lot in accordance with Inspection Level S-2 of MIL-STD-105. The sample unit shall be one pound (0.5 Kilogram). Each unit of the sample shall be visually examined under 20X or greater magnification for conformance to Table III. Nonconformance of the sample to any requirement in Table III shall be cause to reject the lot represented by the sample.

4.4.2.2 Physical property examination. After visual examination, each sample unit selected in 4.4.2.1 shall be tested to the requirements in Table IV. Failure of any test specimen to conform to any requirement in that table shall be cause to reject the entire lot.

4.4.2.3 Packaging inspection.

4.4.2.3.1 Examination for packaging and marking. An examination shall be made to determine that packaging and marking comply with the requirements of Section 5 of this specification. Defects shall be scored in accordance with Table V. The sample unit for this examination shall be one shipping container fully prepared for delivery, except that it shall not be palletized and need not be sealed. Shipping containers fully prepared for delivery that have not been palletized shall be examined for closure defects. The lot size shall be the number of shipping containers in the end item inspection lot. The samples for this examination shall be selected at random in accordance with MIL-STD-105, Inspection Level S-2 and an AQL of 4.0 Defects Per Hundred Units.

4.4.2.3.2 Examination for palletization. An examination shall be made to determine that the palletization complies with the requirements of Section 5 of this specification. Defects shall be scored in accordance with Table VI. The sample unit shall be one palletized unit load fully prepared for delivery. The lot size shall be the number of palletized unit loads in the end item inspection lot. The samples for this examination shall be selected at random in accordance with MIL-STD-105, Inspection Level S-1 and an AQL of 6.5 Defects Per Hundred Units.

4.5 Test methods. Tests shall be performed in accordance with the applicable methods of 4.5.1 through 4.5.7.

4.5.1 ASTM procedures. ASTM test procedures shall be as specified in Table VII.

4.5.2 Particle size.

4.5.2.1 Apparatus. The shaker shall operate with a single eccentric circular motion at  $285 \pm 10$  revolutions per minute and with a tapping action of  $150 \pm 5$  strokes per minute to obtain a dependable sieve analysis. The shaker shall accommodate six 8-inch (20.3 centimeters) diameter sieves with pan and cover. Screen sizes shall conform to U.S. Standard screen sizes as specified in RR-S-366.

4.5.2.2 Procedure. The sieves shall be nested in the order of decreasing size with the largest sieve on top and a pan at the bottom. A sample weighing

100 grams shall be obtained, weighed to the nearest 0.1 gram, and placed on the top sieve of the nest. The nest of sieves with the cover in position shall be placed in the testing machine and vibrated for exactly 3 minutes with the tapper in operation. The abrasive remaining on each sieve and pan shall be weighed and reported. Calculate the necessary percentages to determine compliance with 3.3.

4.5.3 Particle shape. Particle shape shall be noted under 20X or greater magnification for conformance to 3.4.

4.5.4 Undesirable particulates. Light particulates shall be determined using distilled water for Type I and dichloromethane for Types II and III. Heavy particulates shall be determined using dichloromethane for Type I and trichlorotrifluorethane for types II and III.

4.5.4.1 Light particulates. 100 grams of test material shall be added to a tall form, 600ml beaker, followed by 400 mls of the appropriate fluid. The contents shall then be gently stirred for 1 minute and allowed to stand undisturbed an additional 5 minutes. After the 5 minute period, the floating particulates shall be carefully decanted onto a tared, to the nearest 0.001 gram, 200 mesh sieve. Drying and calculations shall be as specified in 4.5.4.3.

4.5.4.2 Heavy particulates. 400 mls of the appropriate fluid shall be added to a 500-ml separatory funnel, followed by 100 grams of test material. The funnel shall be vibrated in an upright position by gently swirling from side to side. Allow the funnel to stand 5 minutes, then drain the settled material into a tared to the nearest 0.001 gram, 200 mesh sieve. Drying and calculations as specified in 4.5.4.3.

4.5.4.3 Drying and calculations. The particulate laden sieves shall be placed in an oven maintained at  $105^{\circ} \pm 1^{\circ}\text{C}$  ( $221^{\circ} \pm 2^{\circ}\text{F}$ ) and dried to constant weight to the nearest 0.001 gram. Percent undesirable particulates shall be calculated as follows:

$$\% \text{ undesirable particulate} = \frac{\text{Weight of residue}}{\text{Weight of material}} \times 100$$

4.5.5 Specific gravity. Four mixtures of perchloroethylene (tetrachloroethylene) and petroleum naphtha shall be prepared adjusting the specific gravity of each to 1.15, 1.25, 1.45, and 1.55. Place 75 ml of each mixture in each of four stoppered 100 ml graduates. Add 30 grams of the abrasive to each graduate, shake vigorously, and allow to stand for 30 minutes. Tap the graduates to detach any air bubbles from the abrasive. Determine compliance with Table II.

4.5.6 pH. One hundred mls of distilled water shall be placed in a 250 ml beaker and the pH measured as specified in ASTM E70. Twenty-five grams of abrasive shall be added to the water and mechanically stirred for 1 hour at room temperature. The pH shall be determined. Conformance to 3.8 shall be noted.

4.5.7 Performance.

4.5.7.1 Panel preparation. An aluminum alloy sheet approximately 6 by 10 by 0.02 inch (15 by 25 by 0.05 cm) shall be treated as follows:

a. Wipe with acetone, then manually abrade with very fine abrasive mat (MIL-A-9962) soaked with deionized water by rubbing back and forth in a single direction until the surface is water break free.

b. Immediately wipe the sheet clean and dry with cheesecloth conforming to CCC-C-440, Class 1.

c. Within 4 hours, immerse the sheet in a MIL-C-81706 aluminum conversion coating solution (1oz/gal) for three minutes. Rinse thoroughly with deionized water for one minute and allow to dry in an upright position.

d. Within 24 hours the sheet shall be painted as specified in Table VIII.

e. The painted sheet shall then be cut into 1 by 3 inch (2.5 by 7.5 cm) strips.

4.5.7.2 Apparatus. A dry blast, glove booth (Zero Manufacturing Co., Order No. BNP55-6 or equivalent) fitted with a blast gun having a 5/16 inch diameter ceramic orifice shall be used. When loaded with 2 liters of material, the air pressure shall be adjusted to 60 psi with the control valve fully open. The test strip shall be secured by screws to a 1/4 inch aluminum table. A mechanism shall be used to translate the table or gun at  $36 \pm 3$  inches per minute such that the blast stream is always normal to the test strip and the impact area moves across the strip paralleling the long dimension and centered on the short dimension. The nozzle of the gun shall always be 6.0 inches from the impact area on the test strip.

4.5.7.3 Procedure. Five painted test strips shall be blasted with the material at an air pressure of 60 psi by making one pass across the strip followed by one pass in the reverse direction. The area of the strip not covered by securing screws shall be examined visually for residual primer or topcoat.

## 5. PACKAGING

5.1 Preservation. Preservation shall be level A or commercial, as specified in the contract or purchase order (see 6.2).

5.1.1 Level A. Level A preservation shall be Method III in accordance with MIL-P-116.

5.1.1.1 Unit packing. The abrasive material shall be placed in paper sacks, fiber drums or plywood drums.

5.1.1.1.1 Sacks. The abrasive material in 50 to 100 pound quantities, as specified, shall be unit packed in multiwall paper sacks that are in accordance with UU-S-48, Type II or III.

5.1.1.1.2 Drums. The abrasive material in 200 to 250 pound quantities, as specified, shall be unit packed in fiber drums that are in accordance with PPP-D-723 type I, II, or III, or in 50 to 200 pound quantities, as specified, in plywood drums that are in accordance with DOT 22A or DOT 22B.

5.1.2 Commercial. Commercial preservation shall be in accordance with ASTM D 3951.

5.2 Packing. Packing shall be level A, level B or commercial.

5.2.1 Level A. In accordance with the contract or purchase order, the specified number of sacks or fiber drums shall be packed in exterior containers conforming to MIL-B-43666, type I or II or PPP-B-601, overseas type or PPP-B-621, overseas type. Abrasive material unit packed in accordance with DOT containers 22A or 22B shall not be packed in exterior containers; the unit pack will be the shipping container.

5.2.2 Level B. Abrasive material unit packed in accordance with UU-S-48 sacks or PPP-D-723 fiber drums will not be packed in exterior containers; the unit pack will be the shipping container.

5.2.3 Commercial. Commercial packing shall be in accordance with ASTM D 3951.

5.3 Unitization. When specified in the contract or purchase order the shipping containers shall be palletized in accordance with MIL-STD-147.

5.4 Marking. In addition to any special marking or labeling indicated in the contract or purchase order, all interior and exterior containers shall be marked in accordance with MIL-STD-129.

## 6. NOTES

6.1 Intended use. The plastic covered by this specification is intended as an abrasive blasting material to clean metal and composite surfaces. Each type allows a product selection that will clean the surface most efficiently without damaging the substrate.

6.2 Ordering data.

6.2.1 Acquisition requirements. Acquisition requirements should specify the following:

- a. Title, number and date of this specification
- b. Whether first article is required (see 6.3)
- c. Part number (see 1.3)
- d. Quantity required
- e. Levels of preservation
- f. Type of container and amount per container (see 5.1.1)
- g. Whether palletization is required

6.3 First article. When a first article inspection is required, the item should be a standard production item from the contractor's current inventory. The contracting officer should include specific instructions in acquisition documents regarding arrangements for examinations, approval of first article test results and disposition of first articles (see 4.3). Invitations for bids should provide that the Government reserves the right to waive the

.. requirement for samples for first article inspection to those bidders offering a product which has been previously acquired or tested by the Government, and that bidders offering such products, who wish to rely on such production or test, must furnish evidence with the bid that prior Government approval is presently appropriate for the pending contract.

Preparing activity:  
Navy - AS  
Project No. 5350-N 008

TABLE I. Particle size distribution.

U.S. Standard Screen Size	12-16		16-20		20-30		30-40		40-60		60-80	
	%Retained Min	Max	%Retained Min	Max	%Retained Min	Max	%Retained Min	Max	%Retained Min	Max	%Retained Min	Max
12	-	0	-	-	-	-	-	-	-	-	-	-
16	60	-	-	0	-	-	-	-	-	-	-	-
20	-	40	60	-	-	0	-	-	-	-	-	-
30	-	-	-	40	75	-	-	0	-	-	-	-
40	-	-	-	-	-	25	75	-	2	-	-	-
60	-	-	-	-	-	-	25	70	-	-	-	5
80	-	-	-	-	-	-	-	-	30	70	-	-
100	-	-	-	-	-	-	-	-	-	-	-	30
PAN	-	1	-	1	-	2	-	3	-	5	-	5

TABLE II. Physical characteristics.

Characteristic	Requirement			Test Para.
	Type I	Type II	Type III	
Specific gravity	1.20±0.05	1.50±0.05	1.50±0.05	4.5.5
Impact strength, ft-lbs/inch of notch	0.2 to 0.4	0.2 to 0.4	0.2 to 0.4	4.5.1
Elongation, percent, max.	5	5	5	4.5.1
Hardness, Rockwell, RHE	20-50	93-98	106-111	4.5.1
Water absorption, %, max.	1.0	1.0	1.0	4.5.1
Fungus resistance, rating	0	0	0	4.5.1

TABLE III. Quality conformance visual inspection.

Examine <sup>1/</sup>	Defect
Material	Not in conformance with 3.2
Particle shape	Not in conformance with 3.4
Workmanship	Not in conformance with 3.9

<sup>1/</sup> Examination under 20X or greater magnification

TABLE IV. Quality conformance tests.

Inspection	Paragraph	
	Requirement	Test
Specific gravity	Table II	4.5.5
Water absorption	Table II	4.5.1
Ash content	Table II	4.5.1
pH of water	3.8	4.5.6

TABLE V. Packaging inspection.

Examine	Defect
Packaging	Container not as specified; closures not accomplished by specified or required methods or materials. Puncture, break, leakage or seepage of contents. Non-conforming component, component missing, damaged or otherwise defective. Bulged or distorted container.
Markings	Data omitted, illegible, incorrect, incomplete, or not in accordance with contract requirements.

TABLE VI. Palletization inspection.

Examine	Defect
Finished dimension	Length, width, or height exceeds specified maximum requirement.
Palletization	Not as specified. Pallet pattern not as specified. Interlocking of loads not as specified. Load not banded with required straps as specified.
Weight	Exceeds maximum load limits.
Marking	Omitted, incorrect, illegible, of improper size, location, sequence or method of application.

TABLE VII. ASTM test methods.

Requirement Paragraph	Characteristic	ASTM Method
Table II	Impact strength	D256 <sup>1/</sup>
Table II	Elongation	D651
Table II	Rockwell Hardness	D785
Table II	Water absorption	D571 <sup>2/</sup>
Table II	Fungus resistance	G21

<sup>1/</sup> determined on 1/8-inch (3.2 mm) thick specimen

<sup>2/</sup> 24 hours at 24±3°C (75±5°F)

TABLE VIII. Performance test panel paint system

Coating	Thickness (mils)	Drying time
MIL-P-23377 (Epoxy primer)	0.6 - 0.9	1 hour
MIL-C-83286, Color No. 17875 (Polyurethane topcoat)	1.7 - 2.3	7 days <sup>1/</sup>

<sup>1/</sup> The sheet shall than be baked an additional 7 days at 66° ± 1°C  
(150° ± 2°F)

NLSA

3 March 1986

Request for Comments on Proposed MIL-A-XXXX(AS), Abrasive Material,  
Plastic for Removal of Paint, Organic Coatings and Surface Contaminants

Department of the Navy  
Naval Air Engineering Center  
Attn: 4121 (Mr H Vasil)  
Lakehurst NJ 08733

1. The following comments are provided on the proposed specification for  
abrasive material, plastic, for removal of paint, organic coatings and  
surface contaminants.

a. Suggested. Change title to: Abrasive Material, Plastic, For  
Removal of Organic Coatings and Surface Contaminants.

b. Essential. 1.1 Scope. Change as follows: This specification  
covers three types of plastic abrasive material for removing surface  
coatings and contaminants from aerospace structure and equipment.

Reason: We have determined that plastic bead paint removal causes  
extensive damage to graphite/epoxy structure. The Air Force does not  
intend to use plastic abrasives of the types covered by this specification  
for paint removal from composite structure. Since this is a materials  
specification for plastic abrasives it should not address the types of  
structural surfaces the abrasive materials may be used on for paint  
removal. Each using activity, based on engineering data, will have to  
decide the types of surfaces that can tolerate plastic abrasives for paint  
removal.

c. Essential. 1.2 Classification. Change as follows:

- Type I - Rockwell hardness E 20 to E 50
- Type II - Rockwell hardness E 93 to E 98
- Type III - Rockwell hardness E 106 to E 111

Do not specify the types of metals for which the abrasive materials can be  
used.

Reason: See "b" above.

d. Suggested. 3.5 Undesirable particulates. We assume that  
"undesirable particulates" is minute sized particles of the same abrasive  
material resulting from the manufacturing process. This requirement  
should be further defined.

C-20

B. Cohen / 3 March 86

DA G-12  
3 March 86

e. Essential. 3.7.1 Cleaning efficiency. This is a "relative" requirement and needs further definition. Specify if the aluminum sheet material is to be bare or clad alloy. Specify the type of aluminum alloy. Depending on whether or not a bare or clad aluminum alloy is specified will dictate if the statement "no surface degradation" can be made since either type of the plastic abrasive will damage clad when it is blasted at 60 PSI nozzle pressure. Also, blasting an 0.02 inch thick aluminum alloy sheet with either type plastic abrasive at 60 PSI nozzle will definitely cause some warpage. Therefore, the extent of "panel degradation" acceptable should be quantified. The referenced test paragraph for this requirement should be para 4.5.7 in lieu of 4.5.6.

Reason: A clad or bare aluminum needs to be specified. After selection of the alloy, quantification of the extent of surface roughness and material warpage needs to be stated.

f. Suggested. 4.5.7.1a Panel preparation. Recommend deoxidizing the aluminum test panels with a phosphoric acid based material such as alcoholic phosphoric acid in lieu of abrading them with an abrasive material. The panel surfaces should be kept as smooth as possible to assess any damage done by the plastic abrasives.

g. Suggested. Para 4.5.7.1b. Change to require immediate rinsing in flowing tap water.

h. Suggested. Para 4.5.7.1c. Change "within 4 hours" to "immediately".

i. Suggested. Table VIII, Foot Note. Recommend baking the panel for 96 hours at 210°F in lieu of 7 days at 150°F.

S.C.  
SIDNEY CHILDERS  
Materials Integrity Branch  
Systems Support Division

3 MAR 86

MLSA

REVISED DRAFT SPECIFICATIONS FOR PLASTIC MEDIA

(June 1987)

NOTE: This redraft, dated June 1987, prepared by the Systems Engineering and Standardization Department, Naval Air Engineering Center, Lakehurst, NJ 08733, has not been approved and is subject to modification.  
DO NOT USE FOR PROCUREMENT PURPOSES  
(DoD Project No. 5350-N008)

MIL-P-XXXXX(AS)

## MILITARY SPECIFICATION

### PLASTIC MEDIA, FOR REMOVAL OF ORGANIC COATINGS

This specification is approved for use within the Naval Air Systems Command, Department of the Navy, and is available for use by all Departments and Agencies of the Department of Defense.

#### 1. SCOPE

1.1 Scope. This specification covers five types of plastic media to be used for removal of organic coatings from aerospace structures and equipment in an abrasive blast operation. Fully cured thermoset products leave almost no surface residue. Thermoplastic products usually leave a residue which interferes with subsequent chemical treatment, unless the stripped surfaces are solvent wiped.

1.2 Classification. The plastic media shall be classified by type and color as follows:

##### 1.2.1 Types.

- Type I - Polyester (Thermoset)
- Type II - Urea Formaldehyde (Thermoset)
- Type III - Melamine formaldehyde (Thermoset)
- Type IV - Phenol formaldehyde (Thermoset)
- Type V - Acrylic (Thermoplastic)

Beneficial comments (recommendations, additions, deletions) and any pertinent data which may be of use in improving this document should be addressed to: Systems Engineering and Standardization Department (Code 53), Naval Air Engineering Center, Lakehurst, NJ 08733-5100, by using the self-addressed Standardization Document Improvement Proposal (DD Form 1426) appearing at the end of this document or by letter.

AMSC N/A

FSC 5350

DISTRIBUTION STATEMENT A. Approved for public release; distribution is unlimited

1.2.2 Colors. Colors are optional for the finished product. When colors are required, they shall be as follows:

- |   |          |   |              |
|---|----------|---|--------------|
| 1 | Type I   | - | Light blue   |
| 2 | Type II  | - | Light yellow |
| 3 | Type III | - | Light pink   |
| 4 | Type IV  | - | Dark brown   |
| 5 | Type V   | - | Grey         |

1.3 Part Numbers. Part numbering system shall be as indicated below. This number is intended for cataloging and ordering purposes.

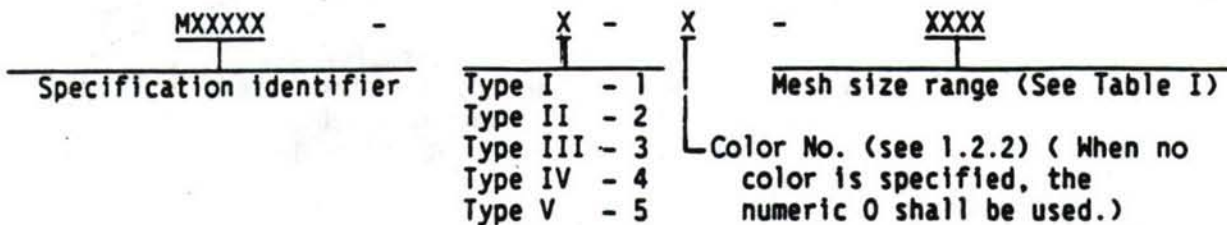

Example. Type I, 12 to 20 mesh size range plastic blast media may be ordered as MXXXXX-1-1-1220 or MXXXXX-1-0-1220

## 2. APPLICABLE DOCUMENTS

### 2.1 Government documents.

2.1.1 Specifications and standards. The following specifications and standards form a part of this specification to the extent specified herein. Unless otherwise specified, the issues of these documents shall be those listed in the issue of the Department of Defense Index of Specifications and Standards (DODISS) and supplement thereto, cited in the solicitation.

## SPECIFICATIONS

### FEDERAL

P-D-680	-	Dry Cleaning Solvent
QQ-A-250/4	-	Aluminum Alloy, 2024, Plate and Sheet
QQ-A-250/12	-	Aluminum Alloy 7075, Plate and Sheet
RR-S-366	-	Sieves, Standard, for Testing Purposes
UU-S-48	-	Sacks, Shipping Paper
CCC-C-440	-	Cloth, Cheesecloth, Cotton, Bleached and Unbleached

## Federal (Continued)

PPP-B-601 - Box, Wood, Cleated Plywood  
 PPP-B-621 - Box, Wood. Nailed and Lock Corner  
 PPP-D-723 - Drums, Fiber

## MILITARY

MIL-P-116 - Preservation, Methods of  
 MIL-A-9962 - Abrasive Mats, NonWoven and Nonmetallic  
 MIL-P-23377 - Primer Coating, Epoxy Polyamide, Chemical and Solvent Resistant  
 MIL-B-43666 - Box, Shipping, Consolidation  
 MIL-C-81706 - Chemical Conversion Materials for Coating Aluminum and Aluminum Alloys  
 MIL-C-83286 - Coating, Urethane, Aliphatic Isocyanate, For Aerospace Application

## STANDARDS

## MILITARY

MIL-STD-104 - Limit For Electrical Insulation Color  
 MIL-STD-105 - Sampling Procedures and Tables for Inspection by Attributes  
 MIL-STD-129 - Marking for Shipment and Storage  
 MIL-STD-147 - Palletized Unit Loads

2.1.2 Other Government documents. The following other Government documents form a part of this specification to the extent specified herein. Unless otherwise specified, the issues shall be those in effect on the date of the solicitation.

## DEPARTMENT OF TRANSPORTATION

DOT 22A - Wooden Drums, Glued Plywood  
 DOT 22B - Wooden Drums, Glued Plywood

(Copies of specifications, standards, handbooks, drawings, and publications and other government documents required by contractors in connection with specific acquisition functions should be obtained from the contracting activity or as directed by the contracting activity.)

2.2 Other publications. The following documents form a part of this specification to the extent specified herein. Unless otherwise specified, the issues of the documents which are DOD adopted shall be those listed in the issue of the DODISS specified in the solicitation. Unless otherwise specified, the issues of documents not listed in the DODISS shall be the issue of the nongovernment documents which is current on the date of the solicitation.

AMERICAN SOCIETY FOR TESTING AND MATERIALS (ASTM)

ASTM D792	-	Test Method for Specific Gravity and Density of Plastics by Displacement
ASTM D2583	-	Indentation Hardness of Rigid Plastics by Means Insulating Materials
ASTM D3951	-	Commercial Packaging
ASTM STP 447 B	-	Manual on Test Sieving Methods

(Application for copies should be addressed to the American Society for Testing and Materials, 1916 Race Street, Philadelphia, PA 19103.)

SOCIETY OF AUTOMOTIVE ENGINEERS (SAE)

AMS 4377	-	Magnesium Alloy, Sheet and Plate, 3.0 Al 1.0 Zn, Cold Rolled, Partially Annealed (AZ31B-H26)
----------	---	--

(Application for copies should be addressed to the Society of Automotive Engineers (SAE), 400 Commonwealth Drive, Warrendale, PA 15096.)

(Nongovernment standards and other publications are normally available from the organizations which prepare or which distribute the documents. These documents also may be available in or through libraries or other informational services.)

2.3 Order of precedence. In the event of a conflict between the text of this specification and the references cited herein (except for associated detail specifications, specification sheets or MS standards), the text of this specification shall take precedence. Nothing in this specification, however, shall supersede applicable laws and regulations unless a specific exemption has been obtained.

3. REQUIREMENTS

3.1 First Article. When specified in the contract or purchase order, a sample of the finished product shall be subjected to first article inspection (see 4.3 and 6.3).

3.2 Materials. The finished product shall be made from non-halogenated cured plastic stock of either polyester (for Type I), urea formaldehyde (for Type II), melamine formaldehyde (for Type III), phenol formaldehyde (for Type IV), or acrylic resin (for Type V), by processing, crushing, and screening to the desired size distribution specified herein. The finished product shall be magnetically cleaned prior to shipment. The finished product shall contain no inorganic fillers. The odor of the finished product shall not be objectionable during actual use.

3.2.1 Hardness of plastic stock. The hardness of the plastic stock prior to crushing shall be within the following limits:

<u>Type</u>	<u>Barcol hardness</u>
I	34 to 42
II	54 to 62
III	64 to 72
IV	54 to 62
V	44 to 52

3.2.2 Color. Dyes or pigments shall be allowed for coloration and shall be blended into the resin prior to cure (see 1.2.2). Where uniform colors are specified, the following color codes shall be used (all colors shall be in accordance with MIL-STD-104):

Type I	Light blue
Type II	Light yellow
Type III	Light pink
Type IV	Dark brown
Type V	White

3.2.3 Sources of plastic stock. The finished product shall be manufactured from selected plastic stock of the exact chemical type required by this specification. The plastic stock may be either scrap plastic (a by product of the manufacture of plastic materials such as shirt buttons, dinnerware, etc.) or virgin plastic (material made specifically for the production of plastic media). An infrared spectrogram of the finished product shall be essentially identical to those in Figures 1 through 5, dependent on type. Mixtures of different types of plastics shall not be permitted.

3.2.4 Explosibility. The finished product shall have a lower explosive limit (LEL) greater than 40 gms/m<sup>3</sup> when tested as specified in 4.5.3.

3.2.5 Toxicity. The finished product shall have no adverse affect on the health of personnel when used for its intended purpose. A Material safety sheet shall be prepared and submitted in accordance with FED-STD-313, one copy of which shall accompany the sample being submitted for first article inspection. Questions pertinent to the effect of the finished product on the health of personnel when used for its intended purpose shall be referred by the acquiring activity to the appropriate medical service (see 4.3.2 and 6.4).

3.3 Physical and chemical properties. The physical and chemical properties of the finished product shall be in accordance with Table I.

3.4 Particle size. The finished product shall have a particle size distribution as shown in Table II.

3.5 Performance. Performance tests shall be determined on finished product conforming to 20-30 particle size distribution. Other sizes of finished product shall be manufactured from the same plastic stock and shall differ only in size distribution resulting from the screening operation.

3.5.1 Paint stripping rate. The finished product (20-30 particle size) shall strip an epoxy/polyurethane topcoat paint system at the following minimum rates, when blasted as specified in 4.5.11.1:

Type	Minimum stripping rate (sq ft/minute)
I	0.25
II	0.50
III	0.50
IV	0.50
V	0.25

Table I. Physical and Chemical Properties.

Requirement	Type				
	I	II	III	IV	V
Ash content, max. (% by wt.)	2.0	2.0	2.0	2.0	2.0
Specific gravity					
minimum	1.20	1.47	1.47	1.47	1.1
maximum	1.25	1.52	1.52	1.52	1.2
Extract content					
max (% by wt.)	5.0	1.0	1.0	4 to 8	1/
pH of water extract	4 to 8	4 to 8	4 to 8	4 to 8	4 to 8
Conductivity					
(mho/cm, max)	100	100	100	100	100
Water absorption					
(% by wt, max)	2.0	10.0	10.0	10.0	2.0
Heavy particulates					
(% by wt, max)	1.0	0.5	0.5	0.5	0.1
Light particulates					
(% by wt, max)	0.1	1.0	1.0	1.0	0.1

1/ No requirement.

TABLE II. Particle size distribution.

U.S. Standard Screen Size	12-20 Maximum % Retain Pass	20-30 Maximum % Retain Pass	20-40 Maximum % Retain Pass	30-40 Maximum % Retain Pass	40-60 Maximum % Retain Pass
12	0.1 --	0 --	0 --	0 --	0 --
20	-- 20	0.1 --	0.1 --	0 --	0 --
30	-- 5	-- 20	-- 60	2 --	0 --
40	-- --	-- 5	-- 20	-- 20	2 --
60	-- --	-- --	-- 5	-- 5	-- 20
80	-- --	-- --	-- --	-- --	-- 10
100	-- 1	-- 2	-- 2	-- 3	-- 5

3.5.2 Aggressiveness. The finished product (20-30 particle size) shall not produce more than the following specific weight losses, when blasted as specified in 4.5.11.2:

Substrate	Maximum weight loss (mg/sq cm)
Aluminum Alloy (QQ-A-250/4)	0.3
Magnesium Alloy (AMS 4377)	10.0
Graphite/epoxy composite (Hercules AS/3501 or equal)	30.0

3.5.3 Product consumption. The percentage of usable material remaining after 5 blast cycles (20-30 particle size) shall not total less than 50 percent by weight, when tested as specified in 4.5.11.3

3.5.4 Surface contamination. Types I thru IV (20-30 particle size) shall not produce a surface residue which interferes with the application of MIL-C-81706 aluminum chromate conversion coating. Blast residues from Type V shall be removable with methyl ethyl ketone.

3.5.5 Anti-static behavior. The finished product (20-30 particle size) shall not cling to the interior walls of the blast cabinet specified herein.

3.6 Storage stability. The finished product (20-30 particle size) shall not progressively harden during storage as determined by increase in aggressiveness (3.5.2), when tested as specified in 4.5.12.

3.7 Workmanship. The finished product shall be manufactured in accordance with the best commercial practice for this type of product and shall be free from any foreign matter.

#### 4. QUALITY ASSURANCE PROVISIONS

4.1 Responsibility for inspection. Unless otherwise specified in the contract or purchase order, the contractor is responsible for the performance of all inspection requirements as specified herein. Except as otherwise specified in the contract or purchase order, the contractor may use his own or any other facilities suitable for the performance of the inspection requirements specified herein, unless disapproved by the Government. The Government reserves the right to perform any of the inspections set forth in the specification where such inspections are deemed necessary to assure supplies and services conform to prescribed requirements.

4.1.1 Responsibility for compliance. All items must meet all requirements of sections 3 and 5. The inspection set forth in this specification shall become a part of the contractor's overall inspection system or quality program. The absence of any inspection requirements in the specification shall not relieve the contractor of the responsibility of assuring that all products or supplies submitted to the Government for acceptance comply with all requirements of the contract. Sampling in quality conformance does not authorize submission of known defective material, either indicated or actual, nor does it commit the Government to acceptance of defective material.

4.1.2 Source inspection. The finished product furnished under this specification shall be source inspected so there is assurance the plastic media meets the Quality Conformance Inspection prior to leaving the manufacturer's plant. The material shall be packaged as specified in Section 5 of this specification. The manufacturer shall maintain a record of the quality test results and a small retain sample, by lot number, for a period of two years. These shall be made available to the Government upon request.

4.2 Classification of inspections. The inspection requirements specified herein are classified as follows:

- a. First article inspection (see 4.3)
- b. Quality conformance inspection (see 4.4)

4.2.1 Inspection conditions. Unless otherwise specified, all inspections shall be performed in accordance with the test conditions specified in the test method document or the applicable paragraph of this specification.

4.3 First article inspection. First article inspection shall consist of all the tests and inspections specified in Table III. There shall be no failures in any requirement.

4.3.1 First article samples. The first article sample shall consist of 325 pounds of finished product packaged as specified in section 5 of this specification. The product shall be produced in the facility to be used in filling the contract or purchase order.

4.3.2 Manufacturer's data. In addition to the first article samples, the manufacturer shall submit 2 copies of a certified test report which show the material forwarded for first article meets all the requirements of this specification. The manufacturer shall certify that the finished product meets the requirements for material (3.2) and storage (3.6). The manufacturer shall also furnish the toxicological data required to evaluate the safety of the material for the proposed use through the submission of the Material Safety Data Sheet detailed in FED-STD-313.

4.4 Quality conformance inspection.

4.4.1 Lot formation. A lot shall consist of 2500 pounds (1250 kg) of the finished product produced from one batch or portion thereof (see 6.3). Each lot shall be identified with sequential numbers.

4.4.2 Sampling and inspection.

4.4.2.1 Visual examination. A random sample of plastic shall be selected from each lot in accordance with Inspection Level S-2 of MIL-STD-105. The sample unit shall be one pound (0.5 Kilogram) which shall be obtained by selective sorting in accordance with ASTM STP 447 B. Each unit of the sample shall be visually examined for conformance to the color and workmanship requirements. Nonconformance of the sample to either requirement shall be cause to reject the lot represented by the sample.

4.4.2.2 Physical property examination. After visual examination, each sample unit selected in 4.4.2.1 shall be tested to the requirements in Table III, except for performance requirements and storage. Failure of any test specimen to conform to any requirement in that table shall be cause to reject the entire lot.

4.4.2.3 Packaging inspection.

4.4.2.3.1 Examination for packaging and marking. An examination shall be made to determine that packaging and marking comply with the requirements of Section 5 of this specification. Defects shall be scored in accordance with Table IV. The sample unit for this examination shall be one shipping container fully prepared for delivery, except that it shall not be palletized and need not be sealed. Shipping containers fully prepared for delivery that have not been palletized shall be examined for closure defects. The lot size shall be the number of shipping containers in the end item inspection lot. The samples for this examination shall be selected at random in accordance with MIL-STD-105, Inspection Level S-2 and an AQL of 4.0 Defects Per Hundred Units.

4.4.2.3.2 Examination for palletization. An examination shall be made to determine that the palletization complies with the requirements of Section 5 of this specification. Defects shall be scored in accordance with Table V. The sample unit shall be one palletized unit load fully prepared for delivery. The lot size shall be the number of palletized unit loads in the end item inspection lot. The samples for this examination shall be selected at random in accordance with MIL-STD-105, Inspection Level S-1 and an AQL of 6.5 Defects Per Hundred Units.

Table III First Article Inspection

Characteristic	Requirement	Test paragraph
Material	3.2	4.5.2
Hardness, plastic stock	3.2.1	4.5.1
Color	3.2.2	Visual
Infrared spectrogram	3.2.3	4.5.2
Explosibility	3.2.4	4.5.3
Ash content	Table I	4.5.4
Specific Gravity	Table I	4.5.5
Extract content	Table I	4.5.6
pH	Table I	4.5.7
Conductivity	Table I	4.5.8
Water absorption	Table I	4.5.8
Particulate contaminate	Table I	4.5.9
Particle size	3.4.	4.5.10
Performance	3.5	4.5.11
Paint stripping rate	3.5.1	4.5.11.1
Aggressiveness	3.5.2	4.5.11.2
Product consumption	3.5.3	4.5.11.3
Surface contamination	3.5.4	4.5.11.4
Anti-static behavior	3.5.5	4.5.11.5
Storage stability	3.6	4.5.12
Workmanship	3.7	Visual

TABLE IV. Packaging inspection.

Examine	Defect
Packaging	Container not as specified; closures not accomplished by specified or required methods or materials. Puncture, break, leakage or seepage of contents. Non-conforming component, component missing, damaged or otherwise defective. Bulged or distorted container.
Markings	Data omitted, illegible, incorrect, incomplete, or not in accordance with contract requirements.

TABLE V. Palletization inspection.

Examine	Defect
Finished dimension	Length, width, or height exceeds specified maximum requirement.
Palletization	Not as specified. Pallet pattern not as specified. Interlocking of loads not as specified. Load not banded with required straps as specified.
Weight	Exceeds maximum load limits.
Marking	Omitted, incorrect, illegible, of improper size, location, sequence or method of application.

**4.5 Test methods.** Tests shall be performed in accordance with the applicable methods of 4.5.1 through 4.5.12, under standard laboratory conditions of  $73.4 \pm 5^\circ\text{F}$  ( $25 \pm 3^\circ\text{C}$ ) and  $50 \pm 10$  percent relative humidity. Finished product samples for tests shall be obtained through selective sorting as specified in ASTM STP 447 B.

**4.5.1 Hardness.** Barcol hardness shall be determined in accordance with ASTM D 2583. The hardness shall be determined on the selected plastic stock before processing to the finished product. The hardness shall be in accordance with the requirement of 3.2.1

**4.5.2 Infrared spectrogram.** The finished product shall be prepared for analysis by pyrolysis using a Spectra-Tech pyrolyzer (Stamford Ct, Model No. PY-2, P/N 0018-002) or equivalent. Place a sample of finished product (up to 50 mg) inside the platinum coil and cover with a potassium bromide plate. Pyrolyze the sample in air at  $900^\circ\text{C}$  ( $1650^\circ\text{F}$ ) for 15 seconds. Allow several minutes for the vapors to deposit, then remove the plate and press a second plate over the condensed pyrolyzate. Determine the infrared spectrogram of the pyrolyzate from 4000 to 400 wavenumbers at a minimum resolution of 2.5 wave numbers.

**4.5.3 Explosibility.** The finished product shall be tested in accordance with the U. S. Department of the Interior, Bureau of Mines recommended practice for determining the explosibility of plastic abrasive media.

**4.5.4 Ash content.** 3.0 grams of finished product shall be weighed into a tared ceramic crucible. The finished product shall be ignited with a fisher burner until no loss of material is visually apparent. The crucible shall be heated in a muffle furnace at  $850^\circ\text{C}$  ( $1560^\circ\text{F}$ ) to constant sample weight. The ash residue shall be calculated as weight percent.

**4.5.5 Specific gravity.** Specific gravity shall be determined in accordance with ASTM D 792 using n-butyl alcohol as the immersion liquid.

**4.5.6 Extract content.** 25 grams of finished product shall be added to a 250 ml beaker, then add 100 ml of methylene chloride, cover with a watch glass and magnetically stir for 1 hour. Filter through a slow fluted filter paper prewashed with methylene chloride. The filtrate shall be washed with an additional 25 ml of the solvent, followed by evaporation to constant weight at  $105^\circ\text{C}$  in a tared container. Extract content shall be calculated as percent weight.

**4.5.7 pH and conductivity.** 25 grams of the finished product shall be added to a clean 100 ml glass graduated cylinder that has been thoroughly rinsed with distilled water. Distilled water shall be added to the 100 ml mark of the cylinder, then stoppered. The cylinder shall be shaken for 5 seconds, then permitted to stand undisturbed for 5 minutes. The cylinder shall then be shaken again and the pH and conductivity of the mixture determined for conformance to the requirement in Table I.

4.5.8 Water absorption. 5 grams of finished product, weighed to the nearest 0.0001 gram, shall be weighed into a tared covered Petri dish. The contents shall be dried in a  $105^{\circ}\pm 2^{\circ}\text{C}$  ( $221^{\circ}\pm 4^{\circ}\text{F}$ ) oven for 1 hour, then covered cooled and reweighed. The uncovered dish shall be placed in 100 percent relative humidity chamber at standard temperature for 24 hours. The dish shall be removed from the chamber, covered, and then reweighed. Water absorption shall be calculated as follows:

$$\text{Water absorption} = \frac{(B-A) \times 100}{A}$$

Where A = weight of dried finished product  
B = weight of moist finished product.

#### 4.5.9 Heavy and light particulate contaminants.

4.5.9.1 Solvent preparation. The solvent shall be prepared from trichlorotrifluoroethane (specific gravity of 1.565) and fluid conforming to P-D-680 (specific gravity of 0.78). Two solvent mixtures shall be prepared to yield the following specific gravities: Mixture A shall be 0.10 greater than the specific gravity of the finished product (for Types II, III, and IV, use pure trichlorotrifluoroethane). Mixture B shall be 0.10 less than the specific gravity of the finished product.

4.5.9.2 Light particulates. 100 grams of the finished product shall be added to a tall form 600 ml beaker, followed by 400 ml of Mixture B. The contents shall be stirred for 1 minute, then allowed to stand for 5 minutes. Any floating particulates shall be decanted onto a 200 mesh screen, tared to the nearest 0.001 gram. The sieve shall be dried to constant weight in an oven maintained at  $105^{\circ}\text{C}$ . The light contaminant particulates shall be calculated as follows:

$$\text{Particulate contamination} = \frac{\text{Residue weight} \times 100}{\text{Sample weight}}$$

4.5.9.3 Heavy particulates. 400 ml of Mixture A shall be added to 500 ml separatory funnel, followed by the addition of 100 grams of the finished product. The funnel shall be vibrated from side to side while in an upright position for 1 to 2 minutes, then be allowed to stand upright for 5 minutes. The settled material shall be drained from the funnel onto a 200 mesh sieve, tared to the nearest 0.001 gram. The sieve shall be dried to constant weight in an oven maintained at  $105^{\circ}\text{C}$ . Heavy particulate contaminants shall be calculated as specified in 4.5.8.2 above.

#### 4.5.10 Particle size distribution.

4.5.10.1 Apparatus. The shaker shall operate with a single eccentric circular motion at  $285 \pm 10$  revolutions per minute and with a tapping action of  $150 \pm 5$  strokes per minute to obtain a dependable sieve analysis. The shaker shall accommodate six 8-inch (20.3 centimeters) diameter sieves with pan and cover. Screen sizes shall conform to U.S. Standard screen sizes as specified in RR-S-366.

4.5.10.2 Procedure. The sieves shall be nested in the order of decreasing size with the largest sieve on top and a pan on the bottom. A sample weighing 100 grams shall be obtained, weighed to the nearest 0.1 gram, and placed on the top sieve of the nest. The nest of sieves with the cover in position shall be placed in the testing machine and vibrated for exactly 3 minutes with the tapper in operation. The abrasive remaining on each sieve and pan shall be weighed and reported. Calculate the necessary percentages to determine compliance with 3.4.

4.5.11 Performance.

4.5.11.1 Paint stripping rate.

4.5.11.1.1 Panel preparation. An aluminum alloy sheet conforming to QQ-A-250/12 approximately 15 by 15 by at least 0.06 inch thick (40 by 40 by at least 0.15 cm) shall be treated as follows:

a. Wipe with acetone, then manually abrade with very fine abrasive mat (MIL-A-9962) soaked with deionized water by rubbing back and forth in a single direction until the surface is water break free.

b. Immediately wipe the sheet clean and dry with cheesecloth conforming to CCC-C-440, Class 1.

c. Within 4 hours, immerse the sheet in a MIL-C-81706 aluminum conversion coating solution (1oz/gal) for three minutes. Rinse thoroughly with deionized water for one minute and allow to dry in an upright position.

d. Within 24 hours the sheet shall be painted as specified in Table VI.

TABLE VI. Performance test panel paint system

Coating	Thickness (mils)	Drying time
MIL-P-23377 (Epoxy primer)	0.6 - 0.9	1 hour
MIL-C-83286, Color No. 36440 or 36495	1.7 - 2.3	7 days <u>1/</u>

1/ The sheet shall then be baked an additional 7 days at  $66^{\circ} \pm 1^{\circ} \text{C}$  ( $150^{\circ} \pm 2^{\circ} \text{F}$ )

4.5.11.1.2 Blasting parameters. Performance testing shall be conducted in a standard direct pressure blasting device. Unless otherwise specified by the manufacturer, the blasting parameters shall be as follows:

- |                                   |    |            |
|-----------------------------------|----|------------|
| a. Nozzle distance from substrate | -- | 10 inches  |
| b. Nozzle size (dia)              | -- | 0.25 inch  |
| c. Media flow rate                | -- | 150 lbs/hr |
| d. Nozzle pressure                | -- | 25 psi     |
| e. Nozzle angle (from horizontal) | -- | 80 degrees |

4.5.11.1.3 Procedure Each painted panel shall be marked to outline a 1 square foot area centered on the panel. The nozzle position shall be fixed within the cabinet and the test panel shall rest horizontally. The test panel shall be moved across the blast stream until the marked area is completely stripped. The stripping rate shall be determined as follows:

$$\text{Stripping rate} = \frac{1 \text{ ft}^2}{\text{Removal time (minutes)}}$$

4.5.11.2 Aggressiveness. Specimen size shall be 0.75 by 1.5 by 0.06 inch (2 by 4 by 0.15 cm). Aluminum (QQ-A-250/4) and magnesium (AMS 4377) specimens shall be cleaned as specified in 4.5.11.1.1, (a) and (b). Graphite/epoxy specimens shall be wiped with acetone and dried with cheesecloth conforming to CCC-C-440, class 1. Each specimen shall be weighed to the nearest 0.0001 gram, then placed in its own protective plastic envelope. Blasting parameters shall be as specified in 4.5.11.1.2 with a blast time of 1 minute. Each specimen shall be situated so the blast of finished product is centered. After blasting, the specimen shall be lightly wiped with a clean lint free cloth and reweighed. All weight loss values shall be in accordance with 3.5.2.

4.5.11.3 Product consumption. Ten pounds of finished product (20 to 30 mesh) shall be charged to the blast hopper. Using the same parameters as in 4.5.11.1.2, operate the blast cabinet to blast a 0.25 inch (0.6 cm) thick aluminum panel conforming to QQ-A-250/12. Repeat for a total of 5 cycles. Weigh the recovered material (R) and obtain a representative 100 to 200 gram sample by using a sample splitter as in ASTM STP 447 B. Determine the percentage of material (P)-retained on a 30 mesh screen. The percent usable material shall be determined as follows:

$$\text{Usable Material} = \frac{R \times P}{10 \text{ lb}}$$

4.5.11.4 Surface contamination. Using a very fine abrasive mat (MIL-A-9962) wet with deionized water, abrade a 4 by 12 by 0.02 to 0.50 inch thick (10 by 30 by 0.05 to 1.2 cm) aluminum test panel conforming to QQ-A-250/4. The test panel shall be thoroughly rinsed with deionized water and wiped dry with bleached cheesecloth (CCC-C-440, Class 1). One half of the aluminum test panel shall be masked with a similar panel. The exposed portion of the test panel shall be blasted for one minute with the finished product as specified in 4.5.11.1.2. The blasted test panel shall be washed with a 10 percent by volume solution of MIL-C-85570, Type II, then swabbed gently with bleached cheesecloth. Panels blasted with Type V media shall also be wiped with cheesecloth wet with methyl ethyl ketone. All panels shall be thoroughly rinsed with deionized water and wiped dry with the cheesecloth. The dried test panels shall be immersed in a chromate conversion coating solution (1 ounce of MIL-C-81706, Class 1 per one gallon deionized water) for three minutes. The panels shall be rinsed with deionized water for one minute. The blasted portion of the test panel shall be compared with the masked portion. A significant difference in color indicates an interfering residue.

4.5.12 Storage stability. The finished product shall be tested for aggressiveness after storage at standard laboratory conditions.

## 5. PACKAGING

5.1 Preservation. Preservation shall be level A or commercial, as specified in the contract or purchase order (see 6.2).

5.1.1 Level A. Level A preservation shall be Method III in accordance with MIL-P-116.

5.1.1.1 Unit packing. The plastic media shall be placed in paper sacks, fiber drums or plywood drums.

5.1.1.1.1 Sacks. The plastic media in 50 to 100 pound quantities, as specified, shall be unit packed in multiwall paper sacks that are in accordance with UU-S-48, Type II or III.

5.1.1.1.2 Drums. The plastic media in 200 to 250 pound quantities, as specified, shall be unit packed in fiber drums that are in accordance with PPP-D-723 type I, II, or III, or in 50 to 200 pound quantities, as specified, in plywood drums that are in accordance with DOT 22A or DOT 22B.

5.1.2 Commercial. Commercial preservation shall be in accordance with ASTM D 3951.

5.2 Packing. Packing shall be level A, level B or commercial.

5.2.1 Level A. In accordance with the contract or purchase order, the specified number of sacks or fiber drums shall be packed in exterior containers conforming to MIL-B-43666, type I or II or PPP-B-601, overseas type or PPP-B-621, overseas type. Plastic media unit packed in accordance with DOT containers 22A or 22B shall not be packed in exterior containers; the unit pack will be the shipping container.

5.2.2 Level B. Plastic media unit packed in accordance with UU-S-48 sacks or PPP-D-723 fiber drums will not be packed in exterior containers; the unit pack will be the shipping container.

5.2.3 Commercial. Commercial packing shall be in accordance with ASTM D 3951.

5.3 Unitization. When specified in the contract or purchase order the shipping containers shall be palletized in accordance with MIL-STD-147.

5.4 Marking. In addition to any special marking or labeling indicated in the contract or purchase order, all interior and exterior containers shall be marked in accordance with MIL-STD-129.

## 6. NOTES

6.1 Intended use. The plastic media covered by this specification is intended as an abrasive blasting material for paint removal. The variation in hardness from one type to another can affect the amount of surface damage produced during blasting operations.

6.2 Ordering data.

6.2.1 Acquisition requirements. Acquisition requirements should specify the following:

- a. Title, number and date of this specification
- b. Part number (see 1.3)
- c. Quantity required
- d. Levels of preservation
- e. Type of container and amount per container (see 5.1.1)
- f. Whether palletization is required

6.3 First article. When a first article inspection is required, the item should be a standard production item from the contractor's current inventory. The contracting officer should include specific instructions in acquisition documents regarding arrangements for examinations, approval of first article test results and disposition of first articles (see 4.3). Invitations for bids should provide that the Government reserves the right to waive the requirement for samples for first article inspection to those bidders offering a product which has been previously acquired or tested by the Government, and that bidders offering such products, who wish to rely on such production or test, must furnish evidence with the bid that prior Government approval is presently appropriate for the pending contract or purchase order.

6.4 Material safety data sheets. Contracting officers will identify those activities requiring copies of completed Material Safety Data Sheets prepared in accordance with FED-STD-313. The pertinent Government mailing addresses for submission of data are listed in appendix B of FED-STD-313.

6.5 Batch. A batch is defined as a homogeneous quantity of finished product, manufactured at one time or representing a blend of several manufactures units of finished product of the same formulation.

6.6 Subject term (key word) listing.

Blast media  
 Paint removal  
 Plastic  
 Thermoset  
 Thermoplastic  
 Scrap stock  
 Virgin stock  
 First article  
 Source inspection

Preparing activity:  
 Navy - AS  
 Project No. 5350-N008

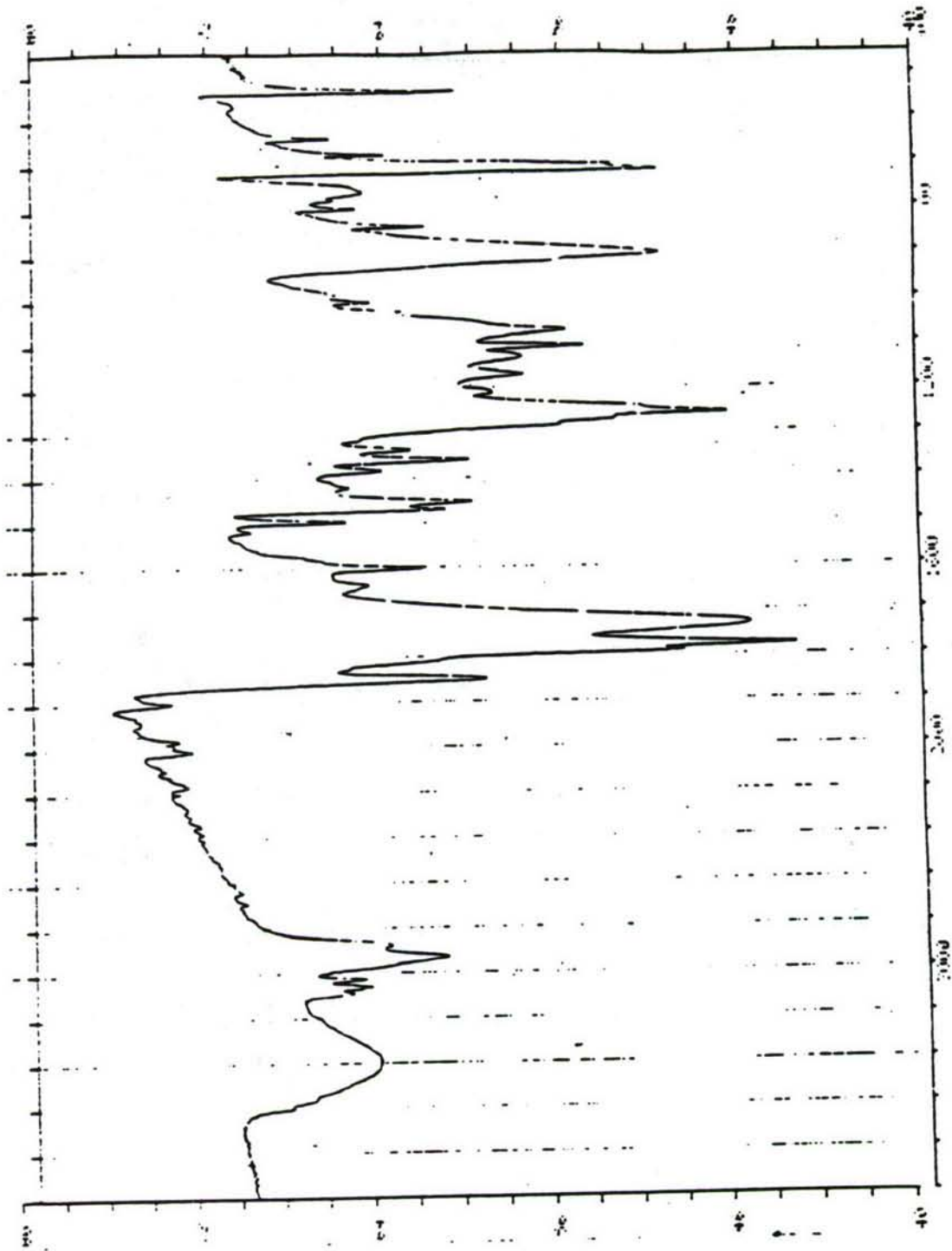

FIGURE 1. Type I Polyester

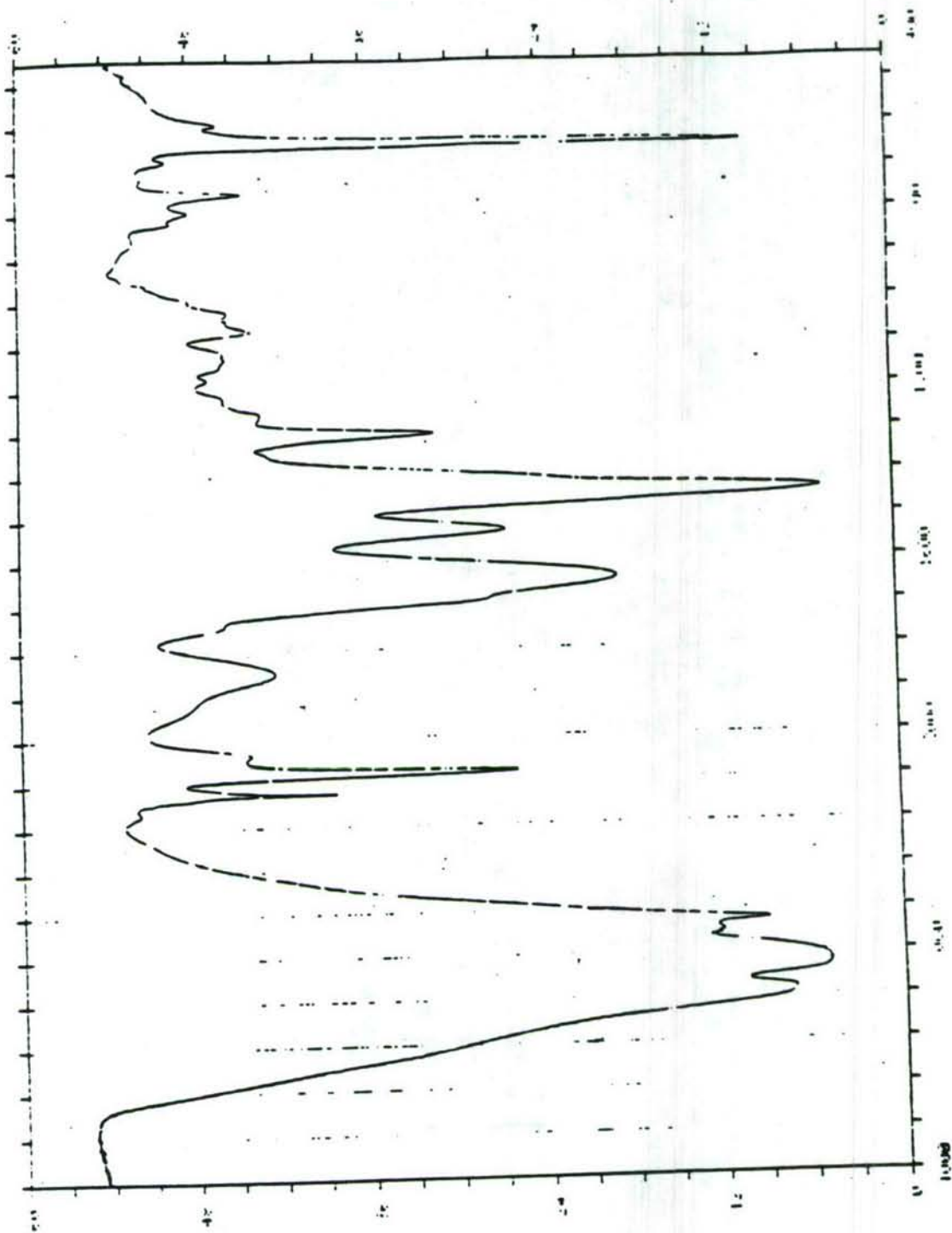

FIGURE 2. Type II Urea Formaldehyde

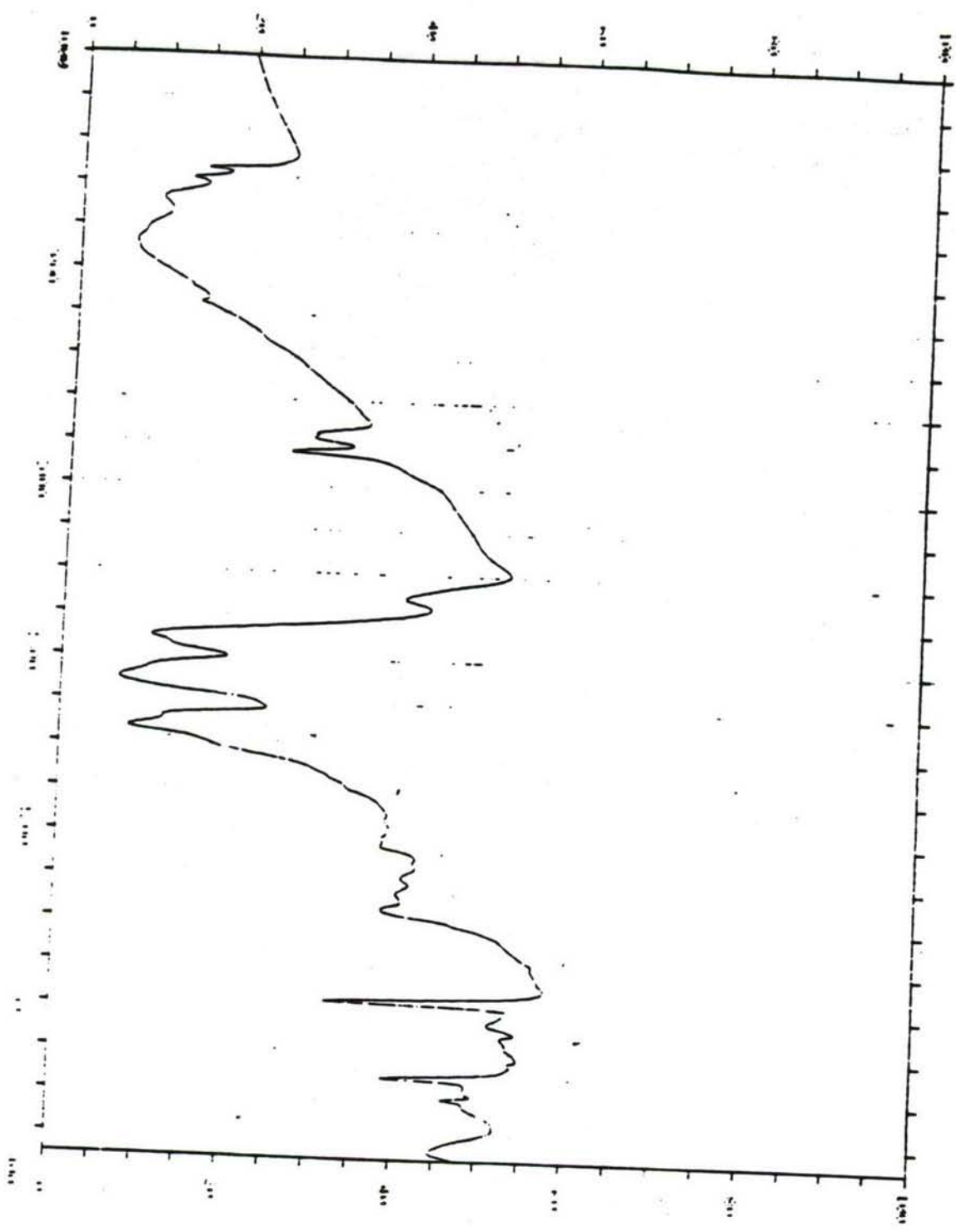

FIGURE 3. Type III Melamine Formaldehyde

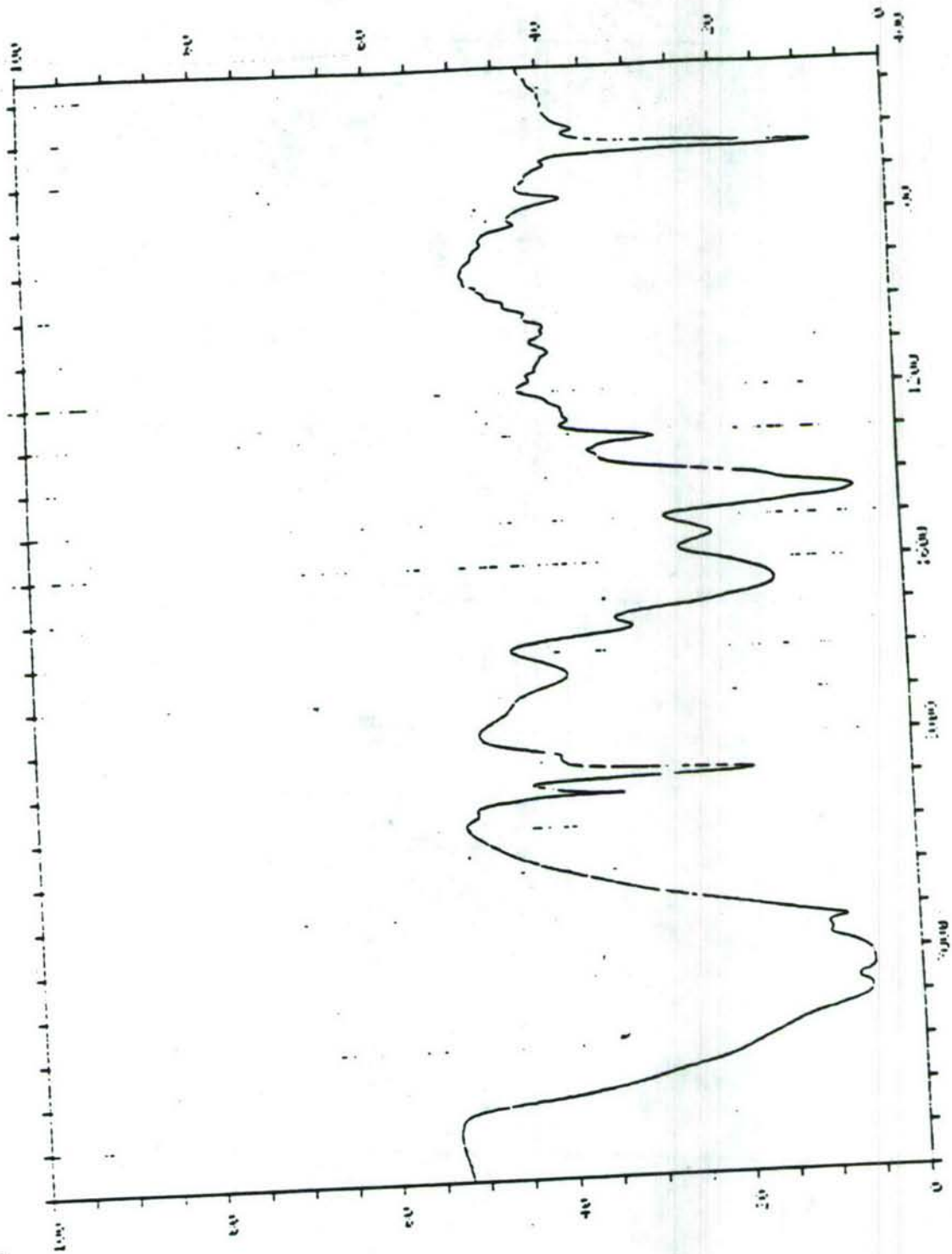

FIGURE 4. Type IV Phenol Formaldehyde

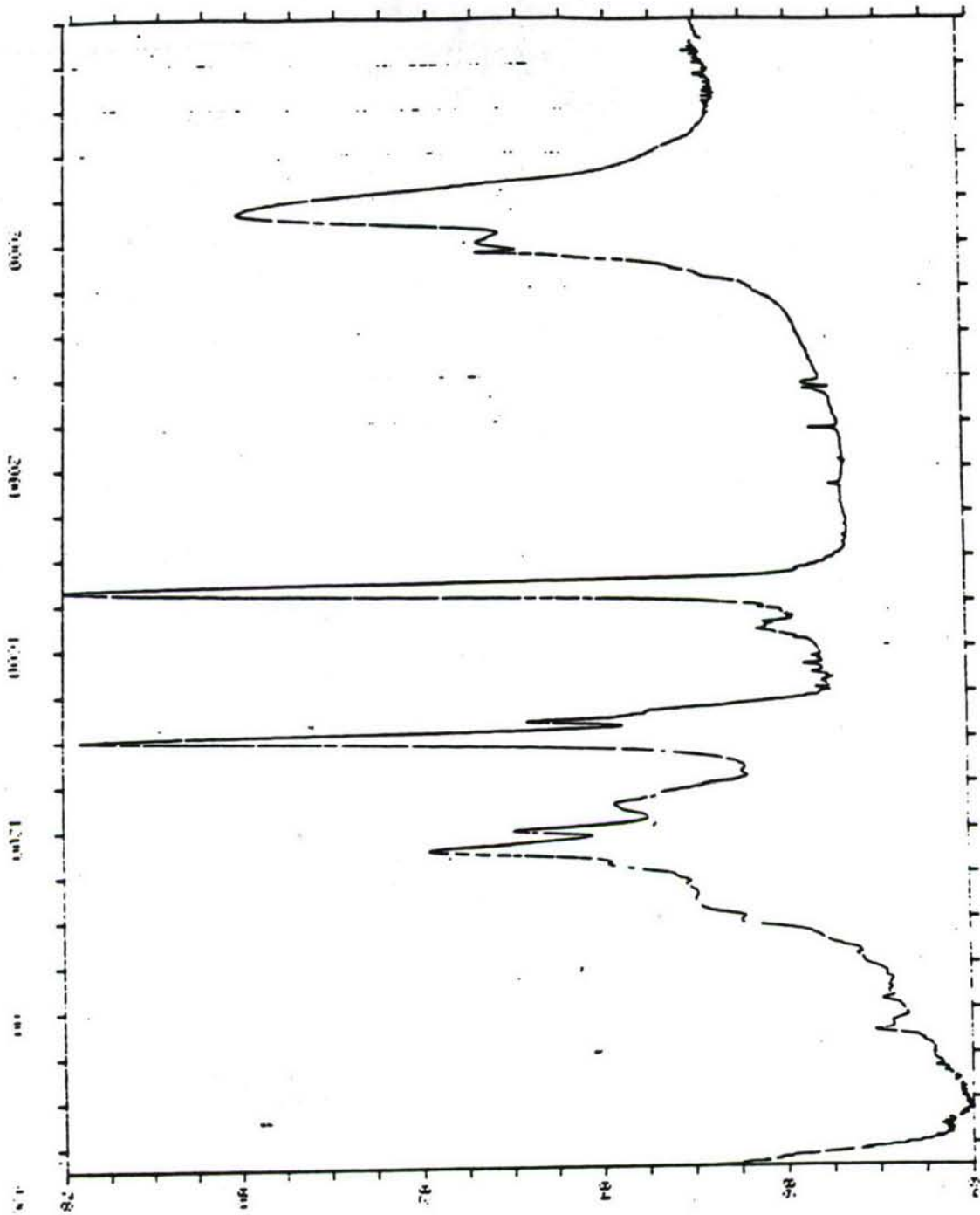

FIGURE 5. Type V Acrylic

APPENDIX D

PMB REPORTS FROM LEAD, AAD, AND RRAD

TABLE OF CONTENTS

	<u>Page</u>
• Anniston Army Depot	D-1
• Letterkenny Army Depot	D-4
• Red River Army Depot	D-12

INFORMATION PAPER

ANNISTON ARMY DEPOT

D-1

## INFORMATION PAPER

Subject: Use of Plastic Media for Paint Removal

1. PURPOSE:

To provide information relative to use of plastic media as an alternate blasting material at Anniston Army Depot.

2. FACTS:

- a. Recently, aircraft industries have been successfully using plastic media to remove paint from thin skinned aluminum aircraft. Previous methodology for large items entailed manual application of a methylene chloride-based phenolic stripper, followed by hand removal of the paint with wire brushes. The procedure was slow, labor intensive, and presented obvious health and environmental hazards. Plastic media blasting has presented a safer method for paint removal without significant removal of or damage to the surface metal.
- b. In preparing ferrous and certain aluminum surfaces for finishing, it is desirable to attain a "white metal" state which necessitates removal of some surface metal. Therefore, plastic media is not a harsh enough abrasive for the majority of our applications. Walnut hull is the abrasive currently in use at Anniston for aluminum items which could be damaged by significant surface removal. There are currently two walnut hull booths in operation at Anniston.
- c. Plastic media was tested as a potential replacement for walnut hull. Although the material cost was higher, it was thought that sufficient recycles could be attained to realize a pay-back. Plastic also has a safety advantage over walnut hull due to the combustible nature of suspended organic dusts in high concentrations. Results of the test:
  1. Cutting efficiencies were about equal (approximately 2 ft<sup>2</sup>/min).
  2. The plastic media would not recycle in our system - even with the exhaust ventilation shut down to a minimum.
  3. Walnut hull will recycle several times prior to exhausting into the dust collection system.
- d. A summary of blasting media used on depot is as follows:
  1. Green Lightning (peridot) - predominate media used for attaining white metal on ferrous surfaces. Replaced silica sand in most operations as a non-toxic inert substitute. Recycles more than silica due to its hardness. Cost = 5 cents/pound.

2. Copper Slag - replaced silica in building 433 as a non-toxic substitute. Not suitable for parts which are to be metal plated or phosphatized due to the incompatibility of the residual dust with those processes. Cost = 1.9 - 2.5 cents/pound.
3. Silica Sand - used in one booth for abrading some parts which are to be phosphatized. These parts experienced coating problems after abrasion with green lightning. Cost = 2 cents/pound.
4. Glass Bead - used in glove boxes for small parts when an abrasive softer than silica is desired. Cost = 31 - 35 cents/pound.
5. Rounded Steel Shot - used in rotatable type blasters for removing heat hardened surfaces without leaving a jagged surface.
6. Garnet (TESTED ONLY) - tried prior to peridot as a non-toxic, inert substitute for silica sand. Harder than sand or peridot and, therefore, recycled more times. Cost was main reason for selection of green lightning rather than this media. Cost = 40 cents/pound.
7. Plastic Media (TESTED ONLY) - tried as a potential replacement for walnut hull. Our dust collection system was not designed for such light weight material and no recycles could be replaced. Cutting efficiency and effect is equal to walnut hull. Cost = \$1.79/pound.

3. CONCLUSIONS/RECOMMENDATIONS:

- a. Walnut hull operations are the only potential use for plastic media at Anniston.
- b. Booths designed for walnut hull would require extensive modification for effective use of plastics.
- c. Walnut hull booths are equipped with blast nozzle/ventilization system interlocks to assure safe operations.
- d. Cutting efficiency of the two media is equal. Therefore, cost vs. benefit would prohibit switching to plastics.

Sue A. Svec  
Health Physicist

INFORMATION PAPER

LETTERKENNY ARMY DEPOT

## Letterkenny Army Depot

### Plastic Blasting Test Program Report-Blast Booth #L-5259 (Bldg 370)

Plastic media blasting has been gaining widespread usage within the commercial and military aircraft maintenance community. Paint removal, through blasting with plastic bead media, has proven to be a very profitable alternative to chemical stripping. Plastic blasting has lead to a savings to cost ratio of nearly 40 to 1 at Hill Air Force Base. Numerous aircraft overhaul facilities have experienced similar savings.

LEAD first became interested in the use of plastic media through observation of the highly successful results being obtained by the aircraft industry. It was felt that the plastic media might be a viable substitute for ag-blast (walnut shell). The lower explosibility, operating pressures, and dust levels obtainable favored use of the plastic media from a safety standpoint. Use of the plastic media would now have to be justified from an economic point of view.

Although plastic blasting has proven to be cost effective when compared to chemical stripping, its use has been difficult to justify on a cost basis when compared to ag-blast. This difficulty can be attributed to the difference in purchase cost of the two medias. At \$1.84 per lb. the plastic media costs nearly 13 times as much as ag-blast. The overall benefits of plastic media in comparison to ag-blast have to be investigated. The following benefits were considered:

- increased operator safety
- higher removal rates
- reduced power consumption
- increased recyclability
- longer equipment life
- less damage to substrate
- reduced masking
- reduction in disposal costs

Of these benefits, the ones likely to result in tangible cost savings were examined. These cost saving areas include higher removal rates, reduced power consumption, and increased recyclability.

The higher removal rates can be attributed to the aggressiveness of the plastic media in comparison to the ag-blast. After initial experimentation with several types of plastic media, a type which retained its aggressiveness at relatively low pressures was selected for testing. Type III (20-30 mesh), produced by U.S. Chemical Corporation, was able to remove the various coatings encountered at reduced pressures and was chosen for the test media. The average blasting times for this media proved to be about 41 percent lower than those for ag-blast (see encl 1).

Reduced power consumption is generated through lowering the operating pressure. A reduction of approximately 15 horsepower is possible through lowering the operating pressure from 70 psi to 40 psi.

The plastic media was found to have a greater recyclability than the ag-blast at their respective operating pressures. During the testing period the plastic media was found to have a media loss rate of 6 lb/hr at 40 psi (see encl 2) compared to 18 lb/hr for ag-blast at 70 psi. The 70 psi operating pressure for ag-blast is required in order

to successfully remove most coatings. Reduced disposal costs may or may not be attained through the lower media loss rates. The possibility exists that the ag-blast residue may be purchased by an outside vendor from DRMO. Also, continuing observations of the blasting operation in blast booth #L-5259 has seen the media loss rate rise steadily. This increased loss rate can be attributed to the operator decreasing the working distance between the work piece and blast nozzle in order to increase removal rates. The following yearly cost comparison for the blasting operation in blast booth #L-5259 (Bldg 370) has been determined using the increased media loss rate observed for plastic bead media of 11 lb/hr.

<u>Media Cost</u>	<u>ag-blast</u>	<u>plastic media</u>
consumption lbs/yr	42,163	15,202
unit price per lb	\$ 0.1452	\$ 1.843
cost per year	\$ 6,114	\$27,972
<u>Hazardous Waste Disposal Costs</u>		
waste produced (drums)	200	121
disposal cost per drum	\$ 147.40	\$ 147.40
total disposal cost	\$29,480	\$17,385
<u>Direct Labor Cost To Blast</u>	\$34,293	\$20,238
<u>Compressed Air Cost</u>	\$ 3,228	\$ 890
Total Operations Cost	\$73,115	\$66,485
<u>Savings of Plastic vs ag-blast</u>		<u>+\$6,530</u>
Total operations cost - Minus Disposal Costs	\$43,635	\$49,100
<u>Savings of Plastic vs ag-blast</u>		<u>-\$5465</u>

As can be seen from this cost comparison, plastic media blasting can be cost effective under the right conditions. However, the yearly loss of nearly \$5500, when considering no disposal costs and the higher media loss rate, is likely. Close supervision of the blasting operation is required when using plastic media. Operating pressures, equipment wear, media purchase costs, and working distances are among the contributing factors that effect the efficiency of the plastic blasting operation. Change in operating conditions can produce disastrous results. The increased media loss rate observed is an example. Control of the operating distance is very difficult due to the nature of the blasting operation. The operator attempts to obtain the highest removal rates possible. Should the pressure be fixed at a low setting, the tendency will be to shorten the working distance. This will have the same effect as increasing the pressure thus increasing the media loss rate.

It is recommended that use of plastic media continue to be monitored in booth #L-5259. Should its use prove not to be cost effective (media loss rate increase, increase in

purchase price of plastic bead, sale of ag-blast residue), its use should be restricted to those items which would otherwise be damaged through use of ag-blast or in lieu of chemical stripping where applicable. The remaining ag-blast rooms in the Directorate for Maintenance (Bldg 350 - L-2542, L-2543, L-50, L-1391; Bldg 57 - L-720; Bldg 37 - L-1294) operate at pressures that would make blasting with plastic media impossible to justify. The high operating pressures used at these booths (100-120 psi) would require pressures of 70-80 psi for plastic blast, in order to obtain similar removal rates. The higher media loss rates and accompanying purchase costs for the plastic media would be enormous. Yearly losses of \$150,000 to \$300,000 could be expected.



Analysis and Notes

1. a. Avg. blast hrs per shift - 4.88
- b. Equivalent plastic blast hrs = .59 x 4.88 - 2.88
- c. Yearly ag-blast consumption a x 18 lb/hr x 240 days/yr x 2 shifts/day - 42,163 lb/yr
- d. Yearly plastic blast consumption b x 11 lb/hr x 240 days/yr x 2 shifts/day - 15,202 lb/yr
2. per Gil Bowling, Bldg 370 Expeditor
3. per Sherry Hubbard, Procurement
4. a. Estimated yearly non-blast media residue (paint dust) - 26,000 lb (app. half of ag-blast consumed)
- b. Drums ag-blast residue (26,000 - 42,163) x 1 drum/340 lb - 200 drums
- c. Drums plastic blast residue (26,000 - 15,202) x 1 drum/340 lb - 121 drums
5. per Charlie Amsley, DRMO
6. a. Yearly direct labor ag-blast 240 days/yr x 2 shifts/day x 4.88 hrs/shift x \$14.64/hr - \$34,293
- b. Yearly direct labor plastic blast 240 days/yr x 2 shifts/day x 2.88 hrs/shift x \$14.64 hour - \$20,238
7. a. Hp required at 70 psi 28.73
- b. Hp required at 40 psi 13.42
- c. Yearly compressed air cost - ag-blast media 28.73 Hp x 1 Kwatt/.74 Hp x 4.88 hr/shift x 2 shifts x 240 days/yr x \$.0355/KWHR - \$3228
- d. Yearly compressed air cost - plastic media 13.42 Hp x 1 Kwatt/.74 Hp x 4.88 hr/shift (1-.41) x 2 x 240 x \$.0355/ KWHR - \$890

Removal Rate Data Ag-blast vs Plastic Media

PART DESCRIPTION	QTY	AG-BLAST		PLASTIC MEDIA			DIFF hr/pc	% DIFF
		BLAST TIME (hrs)	hr/pc	BLAST TIME (hrs)	hr/pc	DIFF hr/pc		
Antenna Hose	12	6	.5	3.6	.3	.2	40	
Cable Reel	20	15	.75	9.0	.45	.3	40	
Launcher Pads	171	38	.22	13.7	.08	.14	62	
Boom Support	26	104	4.0	62.7	2.41	1.59	40	
Antenna	4	160	40.0	110.0	27.50	12.50	31	
Multimeter Case	38	19	.50	6.1	.16	.34	68	
Console	6	24	4.0	11.0	1.83	2.17	54	
Total		366		216			41% Avg	

216/366 = .59

Plastic Blasting Time Required Equal to 59% of Ag-blast

41% Avg Improvement



PLASTIC BEAD RECYCLABILITY

TYPE III 20-30 MESH

BOOTH L-5259 (Bldg 370)



AVERAGE FLOW (Tb/hr)

20

15

10

5

$\frac{1250 \text{ lb}}{124.5 \text{ hr}}$

$\frac{700 \text{ lb}}{116.7 \text{ hr}}$

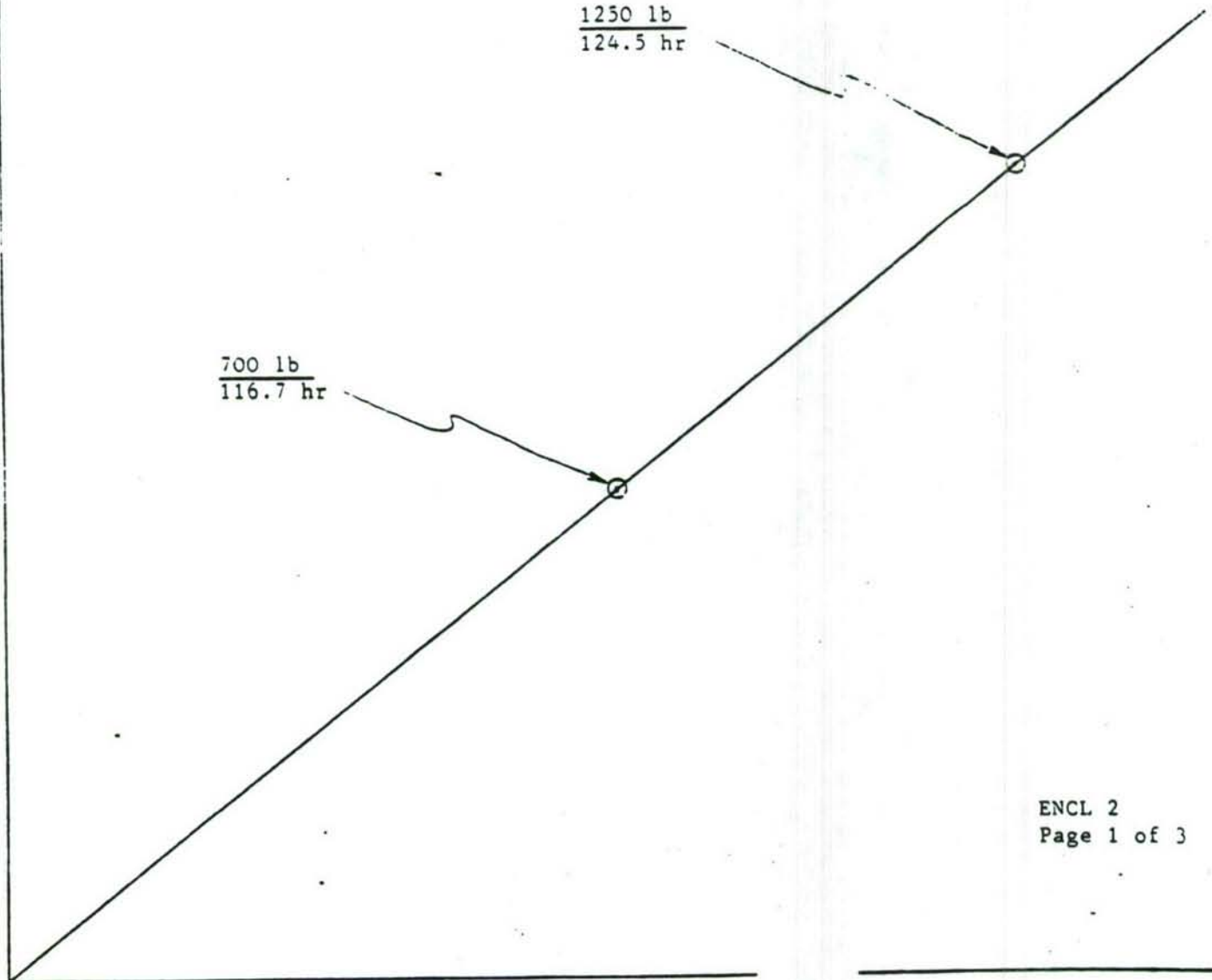

35 PRESSURE (PSI) 40

D-9

45

RECYCLABILITY DATA SHEET - TYPE 111 20-30 MESH @ 60 PSI

<u>DATE</u>	<u>MEDIA ADDED (lb)</u>	<u>TIME LAPSE (hr)</u>	<u>lb/hr</u>
12-11	60	13.2	4.5
12-11	60	8.0	7.5
12-12	60	4.3	14.0
12-13	60	11.1	5.4
12-14	60	10.5	5.7
12-16	60	8.3	7.2
12-16	40	5.0	8.0
12-18	60	10.1	5.9
12-19	60	13.3	4.5
12-23	60	10.3	5.8
12-24	60	4.2	14.3
12-30	<u>60</u>	<u>18.4</u>	<u>3.3</u>
	700	116.7	6.0 lb/hr avg.



RECYCLABILITY DATA SHEET - TYPE 111 20-30 MESH @ 45 PSI

<u>DATE</u>	<u>MEDIA ADDED (lb)</u>	<u>TIME LAPSE (hr)</u>	<u>lb/hr</u>
11-26	120	10.4	11.5
11-27	160	9.8	16.3
11-29	150	10.0	15.0
12-4	110	15.6	7.1
12-5	90	12.6	7.1
12-6	60	10.5	5.7
12-9	90	12.0	7.5
12-10	90	7.5	12.0
12-19	70	4.8	14.6
12-30	60	4.7	12.8
1-2	70	6.5	10.8
1-3	60	6.6	9.1
1-6	60	8.1	7.4
1-6	<u>60</u>	<u>5.4</u>	<u>11.1</u>
	1250	124.5	10.0 lb/hr avg.



INFORMATION PAPER

RED RIVER ARMY DEPOT

D-12

POINT PAPER

SUBJECT:

Plastic Media Blasting

PURPOSE:

To determine if plastic blast media is a safe and effective method of paint removal from Army vehicles and components.

FACTS:

RRAD performs extensive blasting operations on aluminum and ferrous surfaces.

Blasting media used were steel grit and shot, silica sand, glass beads, walnut hulls.

Steel shot can set-up corrosion cells on aluminum.

Silica sand is inexpensive and safe for use on aluminum but environmental and hygiene standards governing its use are becoming increasingly restrictive.

Walnut hull use has been eliminated in compliance with OSHA Standard L910.94(A)-2111.

Glass beads are expensive and not suitable for some abrasive cleaning requirements.

Plastic media is one of several materials being evaluated by RRAD as a replacement for silica sand.

RRAD has sent representatives off depot to demonstrations utilizing plastic media.

RRAD has allowed companies to demonstrate plastic media blasting on depot.

RRAD has received proposals from various equipment and media manufacturers for installations at RRAD.

RRAD has concluded the following:

- Plastic media is slower than sand but faster than walnut hulls in removing paint from aluminum.
- Plastic media is safer and more environmentally acceptable than sand.

- Plastic media breaks down to unusable particles much faster than sand.
- Plastic media cost is approximately \$2.15 per pound. Sand cost is about \$0.02 per pound.

Edward R. Hanna

APPENDIX E

PAINT THICKNESS GAUGE MEASUREMENT PROCEDURES

TABLE OF CONTENTS

	<u>Page</u>
• Minitector 150	E-1
• Inspector Thickness Gage	E-5

MINITECTOR 150  
THICKNESS GAUGE  
TYPE N  
INSTRUCTION MANUAL

ELCOMETER INSTRUMENTS LIMITED,  
EDGE LANE,  
DROYLSDEN,  
MANCHESTERE,  
M35 6BU.  
ENGLAND.

Tel: 061-370-7611  
Telex: 668960

Manual Part Number

## SECTION 1

### Use of Controls:

#### 1.1 Front Panel Controls

(See illustration 1)

##### 1.1.1. Function Switch

- O - Off
- B - Battery Test Position
- ON - Instrument in Operation
- H - Hold facility  
(optional extra)

##### 1.1.2 Range Selection Switch

- I - Scale I upper scale
- II - Scale II centre scale
- III - Scale III lower scale

##### 1.1.3 Zero

Fine Zero adjusting control - ten turns; clockwise rotation increases meter reading.

##### 1.1.4 Cal

Sensitivity control (meter full scale deflection) ten turns; clockwise rotation increases meter reading.

#### 1.2 Rear Panel Controls

1.2.1 Zero I - II coarse zero control for scales I and II

1.2.2 Zero III - IV coarse zero control for scale III (scale IV for FN instrument only).

Both controls are turned clockwise looking at the back of the instrument to increase meter reading.

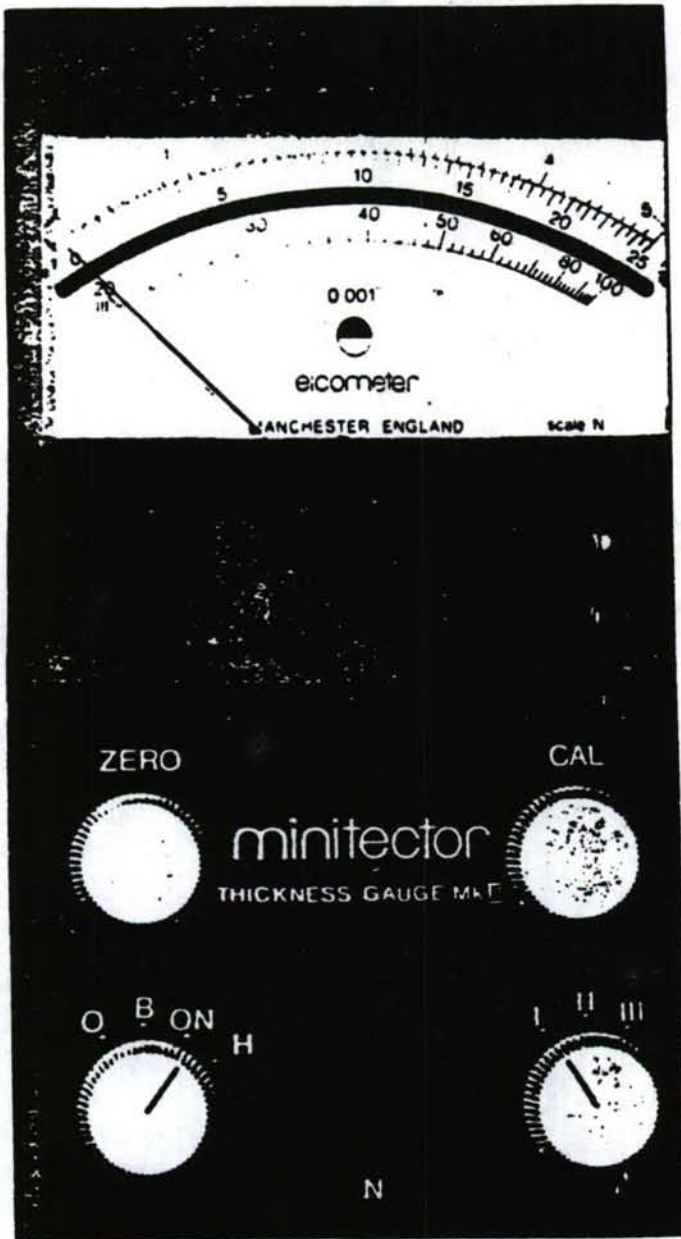

## SECTION 2

### Initial Checks:

#### 2.1 Meter Zero

Before putting the instrument into operation, check that the meter reads mechanical zero. This can be adjusted by turning the screw located on the back of the instrument just below the battery compartment cover.

#### 2.2 Fitting of Batteries

When the instrument leaves the factory, the batteries are packed separately and these must be put into the instrument before use. The battery compartment is located beneath the top hinged flap at the back of the instrument which can be lifted by inserting a coin or thumbnail in the slot at the top of the case.

The batteries should now be fitted, ensuring that the positive contact (+) corresponds with the contact marked (+) in the battery compartment.

#### 2.3 Battery Check

Switch to the battery test position (indicated by the letter B). The pointer should read to the right of the battery mark B on the scale. If the reading is close to the mark or to the left of it, then both batteries must be replaced.

#### 2.4 Probe Connection

The probe is plugged into the socket situated on the lower right hand side of the instrument case, making sure that the plug is pushed home firmly. Care must be taken when making this connection to ensure that locating assemblies match each other, otherwise damage can occur to the connection pins in the instrument case socket.

To remove, pull on the outer sleeve to slide it back and disengage the latch; the plug will then come out of the socket.

## SECTION 3

### Calibration:

#### 3.1 Setting the Zero

Turn the range switch to the most sensitive range (Range 1) and switch the instrument on.

Place the probe on an uncoated piece of non-ferrous metallic material, ideally of the same finish, shape and composition as the coated material on which it is desired to make the measurement.

Adjust the zero control until the pointer reads zero, making sure that the pointer and its mirror image are in line.

Take several readings in the same area on the sample material and adjust the zero control so that the mean of the readings is zero.

### 3.2 Scales not Starting at Zero

Where the minimum thickness of a particular scale is not zero, a calibration foil should be selected from those supplied with the instrument of a thickness corresponding to the minimum reading of the scale.

N.B. The foils are only of nominal thickness and for maximum accuracy the actual thickness should be ascertained using a micrometer or similar instrument.

The appropriate calibration foil is now placed between the probe and the substrate and the zero control adjusted as before, until the instrument indicates the correct thickness. Again several readings should be taken and the zero control adjusted until mean of the readings is correct.

### 3.3 Coarse Zero

If the adjustment of the zero control is insufficient to obtain a correct reading, coarse zero controls are provided at the back of the instrument beneath the lower hinged flap.

To obtain the correct setting for these, turn the zero knob to its mid-position (5 turns from either end) and adjust the appropriate coarse zero control using a small screwdriver until the meter is reading correctly with the probe in contact with the substrate or foil as mentioned before.

The final zero adjustment can then be made using the front panel zero control.

### 3.4 Setting the Full-Scale Deflection

Select a foil corresponding to the maximum thickness of the scale being calibrated, again checking its actual thickness with a micrometer if maximum accuracy is to be obtained. Place the foil between the probe and the substrate and adjust the CAL control until the correct scale reading is obtained. Take several readings at the same point and adjust the CAL control until the mean of the readings is correct.

The calibration should be rechecked at both ends of the scale and any necessary readjustments made until no further improvement can be obtained.

The instrument is now ready for use.

As the calibration procedure takes only a short time to complete, we recommend that it be done each time it is desired to use the instrument. Owing to the high stability of the electronic circuitry, negligible drift of meter reading may occur if repeated measurements on similar samples are being taken over long periods of time. Recalibration will be necessary, however, if any parameter of the substrate is changed, e.g., the surface finish or curvature.

**INSPECTOR THICKNESS GAGE  
OPERATING INSTRUCTIONS**

E-5

## OPERATING INSTRUCTIONS

- 1) Place gauge (see illustration) on clean, depainted ferrous surface, pressing end with magnet firmly on flat surface.
- 2) Turn scale to maximum reading (25 mils).
- 3) Keeping magnetic end firmly on surface, turn scale down until magnet pulls away from metal surface, making a "popping" sound. Using a screwdriver, adjust the Set Zero so the gauge reads zero for the depainted surface.
- 4) Repeat Steps 2 and 3 five times and take the average value to set the zero point.
- 5) For painted surface, keep magnetic end firmly on surface, turn scale to maximum reading (25 mils), turn scale down until magnet pulls away from metal surface, making a "popping" noise. Read scale for paint thickness (reading in mils).
- 6) Repeat Step 5 three times and take the average value to determine paint thickness.

PAUL N. GARDNER COMPANY

## INSPECTOR THICKNESS GAGE

For measuring dry film thickness of any non-magnetic material on a ferrous base, including paint, electroplating, porcelain enamel, rubber, plastic, asphalt, varnish, metal spraying, fiber glass, foils (placed on flat steel base) and many other coatings.

**NON-DESTRUCTIVE**

**MEASUREMENTS**  
at any angle.

**LIGHT WEIGHT**  
only 8½ oz.

**POCKET SIZE**  
2" x 1¼" x 9"

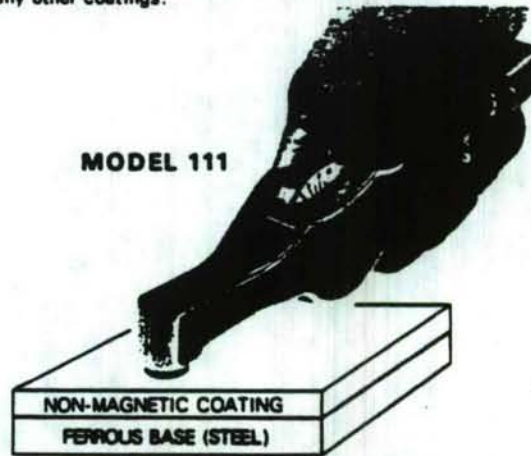

A rugged die cast aluminum case, containing a pivoted-arm assembly fitted with a permanent magnet at one end, the other end is fitted with a counter weight. A coil spring is attached to the pivot and to the calibrated scale ring.

### PRINCIPLE OF OPERATION:

The magnet of the INSPECTOR is placed vertical to the surface. Variations in film thickness of the dried coating above the ferromagnetic base alter the attractive force of the magnet. This unknown force is determined by turning the scale ring by hand to apply tension to the spring. When the spring tension just exceeds the unknown magnetic attractive force, the magnet breaks contact with the coated surface. The film thickness is read directly from the calibrated scale, either in mils or microns.

### Available in Three Scale Ranges:

111/A - A - INSPECTOR THICKNESS GAGE, 0-25 THOUSANDTHS (MILS).

111/B - B - INSPECTOR THICKNESS GAGE, 0-500 MICRONS.

111/C - C - INSPECTOR THICKNESS GAGE, 10 to 70 THOUSANDTHS (MILS).

SUPPLIED COMPLETE WITH LEATHER CASE, SHOULDER STRAP, WRIST STRAP, NON-PRECISION SHIMS AND INSTRUCTIONS. . . . . \$115.00 each

PAUL N. GARDNER COMPANY  
2280 S. E. 17th STREET  
FORT LAUDERDALE, FLORIDA 33316

Phone (305) 523-1679

2-A

E-7

DISTRIBUTION LIST

Defense Technical Information Center 12  
Cameron Station  
Alexandria, Virginia 22314

Defense Logistics Studies Information Exchange 2  
U.S. Army Logistics Management Center  
Fort Lee, Virginia 23801

Commander  
U.S. Army Toxic and Hazardous Materials Agency 2  
Attn: AMXTH-CO-P  
Aberdeen Proving Ground, Maryland 21010-5401

Commander  
U.S. Army Toxic and Hazardous Materials Agency 14  
Attn: AMXTH-TE-D  
Aberdeen Proving Ground, Maryland 21010-5401

~~M. Worsham Due Back 9/19/94~~