

REPORT DOCUMENTATION PAGE

Form Approved
OMB No. 0704-0188

Public reporting burden for this collection of information is estimated to average 1 hour per response, including the time for reviewing instructions, searching existing data sources, gathering and maintaining the data needed, and completing and reviewing this collection of information. Send comments regarding this burden estimate or any other aspect of this collection of information, including suggestions for reducing this burden to Department of Defense, Washington Headquarters Services, Directorate for Information Operations and Reports (0704-0188), 1215 Jefferson Davis Highway, Suite 1204, Arlington, VA 22202-4302. Respondents should be aware that notwithstanding any other provision of law, no person shall be subject to any penalty for failing to comply with a collection of information if it does not display a currently valid OMB control number. **PLEASE DO NOT RETURN YOUR FORM TO THE ABOVE ADDRESS.**

1. REPORT DATE (DD-MM-YYYY) 31-07-2006		2. REPORT TYPE Technical Paper		3. DATES COVERED (From - To)	
4. TITLE AND SUBTITLE A Novel Distributed Ignition Method Using Single-Wall Carbon Nanotubes (SWCNTS) and a Low-Power Flash Light (Preprint)				5a. CONTRACT NUMBER	
				5b. GRANT NUMBER	
				5c. PROGRAM ELEMENT NUMBER	
6. AUTHOR(S) B. Chehroudi (ERC); S.A. Danczyk (AFRL/PRSA)				5d. PROJECT NUMBER	
				5e. TASK NUMBER 23080533	
				5f. WORK UNIT NUMBER	
7. PERFORMING ORGANIZATION NAME(S) AND ADDRESS(ES) Air Force Research Laboratory (AFMC) AFRL/PRSA 10 E. Saturn Blvd. Edwards AFB CA 93524-7680				8. PERFORMING ORGANIZATION REPORT NUMBER AFRL-PR-ED-TP-2006-245	
9. SPONSORING / MONITORING AGENCY NAME(S) AND ADDRESS(ES) Air Force Research Laboratory (AFMC) AFRL/PRS 5 Pollux Drive Edwards AFB CA 93524-7048				10. SPONSOR/MONITOR'S ACRONYM(S)	
				11. SPONSOR/MONITOR'S NUMBER(S) AFRL-PR-ED-TP-2006-245	
12. DISTRIBUTION / AVAILABILITY STATEMENT Approved for public release; distribution unlimited (AFRL-ERS-PAS-2006-186).					
13. SUPPLEMENTARY NOTES Presented at the Global Powertrain Congress – World Powertrain Exposition 2006, Novi, MI, 19-21 September 2006.					
14. ABSTRACT This paper describes a low-power novel ignition method that uses the energy of a single exposure of an ordinary camera flash and SWCNTs to ignite various fuels. It is shown that this method is able to ignite solid, liquid, and gaseous fuels. The effects of the iron (Fe) nanoparticles (embedded in the SWCNTs) concentration on the ignition process have been studied. One application of this nano-technology based ignition method has been successfully demonstrated through an ignition of a single liquid fuel droplet, suggesting that this method may be extended to ignite liquid fuel sprays. This is important as fuel sprays are used in most engines to atomize the liquid to an ensemble of droplets. This new ignition method may also be extended to achieve “distributed ignition” that would allow ignition to occur in numerous locations simultaneously. Such plurality of ignition sites is important in control of ignition event in homogeneously-charged compression ignition (HCCI) engine applications. HCCI operating mode is considered by many to be an important component of the future automotive engine for high efficiency and low emission of harmful pollutants.					
15. SUBJECT TERMS					
16. SECURITY CLASSIFICATION OF:			17. LIMITATION OF ABSTRACT	18. NUMBER OF PAGES	19a. NAME OF RESPONSIBLE PERSON
a. REPORT	b. ABSTRACT	c. THIS PAGE			19b. TELEPHONE NUMBER <i>(include area code)</i>
Unclassified	Unclassified	Unclassified	SAR	9	N/A

A NOVEL DISTRIBUTED IGNITION METHOD USING SINGLE-WALL CARBON NANOTUBES (SWCNTS) AND A LOW-POWER FLASH LIGHT

B. Chehroudi* and S. A. Danczyk⁺

⁺
Air Force Research Laboratory/ PRSA
10 E Saturn Blvd
Edwards AFB, CA 93524-7680
Stephen.Danczyk@Edwards.af.mil
(661) 275-6208

*
Engineering Research Consultants
P O Box 1718
Lancaster, CA 93539
ChehroudiB@aol.com
(805) 559-8353

Global Powertrain Congress World Powertrain Exposition

Novi, Michigan
September 19-21, 2006

ABSTRACT

This paper describes a low-power novel ignition method that uses the energy of a single exposure of an ordinary camera flash and SWCNTs to ignite various fuels. It is shown that this method is able to ignite solid, liquid, and gaseous fuels. The effects of the iron (Fe) nanoparticles (embedded in the SWCNTs) concentration on the ignition process have been studied. One application of this nano-technology based ignition method has been successfully demonstrated through an ignition of a single liquid fuel droplet, suggesting that this method may be extended to ignite liquid fuel sprays. This is important as fuel sprays are used in most engines to atomize the liquid to an ensemble of droplets. This new ignition method may also be extended to achieve "distributed ignition" that would allow ignition to occur in numerous locations simultaneously. Such plurality of ignition sites are important in control of ignition event in homogeneously-charged compression ignition (HCCI) engine applications. HCCI operating mode is considered by many to be an important component of the future automotive engine for high efficiency and low emission of harmful pollutants.

INTRODUCTION

An ignition process can be defined as a transformation of a system of reactants from essentially a non-chemically reacting condition to a self-sustained, rapidly-reacting state. This overall process usually consists of two basic steps. The first is the creation of a combustible mixture of fuel and the second is the elevation of the fuel/oxidizer mixture to an ignition temperature.

For automotive engines, ignition is at the heart of the smooth and efficient operation of spark-ignited (SI) engines. Cyclic variability, misfire, and weak ignition are mostly caused by poor ignition system, see Heywood [1]. In addition, due to emission and fuel economy constraints, intensive research is directed towards HCCI engine in which the fuel and air are mixed homogeneously (similar to SI engines) but ignition occurs through a similar approach as in diesel engines, that is, through autoignition where ignition takes place at a large number of randomly distributed sites (i.e., distributed ignition), see Chehroudi [2]. One main issue with the HCCI engine is control of the ignition event in each cycle. It will become clear why the ignition method researched here can contribute towards this issue. In liquid rocket engine applications, one of the most challenging engineering problems is the creation of an ignitable mixture at the engine startup phase. Unlike chemical reactors, there is insufficient time available for complete propellant mixing in rockets. Therefore, a potentially dangerous situation is created if ignition is not successful immediately after the initial flow of propellants into the combustion chamber. This is mainly due to an accumulation of a large quantity of high-energy propellants in the chamber. Even a small quantity (1-2 ml for thrusters & 100ml for booster) of accumulated propellants can result in substantial structural damage caused by the potential occurrence of detonation. Hence, *ignition reliability is essential for engines*.

Achieving an ignitable mixture ratio, physically located within a spatially-narrow ignition zone (such as a spark volume) at the time when an ignition system is activated, is an important task, especially for stratified-charged SI and rocket engines. This matter is even more important for liquid cryogenic rockets (such as space shuttle main engine) where temperature differences between the separate streams of the propellants can delay the vaporization process due to cooling of one propellant by the other

during the initial mixing event causing variability in the location of the ignitable mixture with respect to the injector face plate. Therefore, it is generally desirable that an ignition system *distribute its energy within a sufficiently-large volume* in the combustion chamber to assure both capture and ignition of pockets of combustible mixtures existing inside the so-called ignition limits, see Dale and Oppenheim [3].

Equally challenging, is efficient storage and transmission of the ignition energy. Energy is obviously needed to activate any ignition system. There are two issues here, namely, storage of the energy and its transmission to the ignition zone in the combustion chamber. Since engines (especially rockets) are sensitive to added weight, the mass of the energy storage medium must be minimized. Basic physics suggests that the amount of energy stored is roughly proportional to the mass of the energy storage device itself. The most common forms of energy storage are a battery and chemical energy stored in a solid/pyrotechnic propellant grain. The stored energy can present a major engineering challenge, primarily due to the hazards of uncontrolled, spontaneous activation or malfunction of the storage system itself. Large improvements in operability, reduction in cost, and improvements in reliability can be achieved by either lowering the quantity of the required energy stored or creating a high specific energy (J/kg) storage method, which is difficult to achieve due to the potential of an inadvertent energy release. The stored energy must also be transmitted to the igniter unit with a minimum of loss. Then *an efficient transfer of the stored energy into thermal energy* within the combustible mixture is needed. Once the energy is efficiently delivered to an igniter, it must be converted into a usable form for ignition purposes. The nature of the energy transfer at this stage varies. For example, it may be through a spark when electricity is used or via an injection of hot products when pyrotechnics or flame-jet methods are employed.

Although many ignition methods exist, by far the most popular one is the electric spark igniter. It requires high-energy input supplied by a high-voltage circuitry often consisting of heavy components, and by its nature is a single-point stimulus method. Other ignition methods such as plasma jet injection or flame jet initiation, and high-power laser ignition are all bulky, heavy, energy-intensive, and expensive to operate. Other approaches to ignition can be through the usage of pyrophoric charges, via the mixing of hypergolic chemical components, or through activation over a catalytic bed, all of which either makes use of hazardous chemicals and/or of highly-specialized materials or sophisticated mixing machinery. Again, these are either single-point ignition methods, as in the case of focused-beam laser, or limited to a narrowly-defined region in the combustion chamber, uncontrollable by the operator once the hardware is built.

Another disadvantage of these ignition systems, with the exception of perhaps lasers which has a limited flexibility, is that once they are installed on an engine, the ignition location remains fixed with respect to the combustion chamber. It is often preferable to have a plurality of ignition points to initiate a uniform or well-distributed combustion initiation. However, using the above-described fixed-point ignition techniques, multi-point ignition within a chamber can only be achieved by repeated implementation of the same ignition-specific hardware, which spatially can be very restrictive to attain in addition to increasing the size and mass of the engine. Additionally, the ability to select and continuously vary the ignition locations or regions in an engine as a parameter, or *"distributed ignition,"* is a critical and useful engineering design strategy for developing highly-efficient and possibly more stable combustion chambers, see Dale and Oppenheim [3]. For example, current ignition methods in rockets are known to possess one or more other disadvantages such as causing combustion instability and start-up transients which not only can cause severe damage but also degradation in engine efficiency and increase emission of pollutants. Thus, *an ignition method is needed which is effective, multi-point or distributive in nature, while allowing design versatility in decreasing engine size and overall mass.* At the same time, such a method is expected to exhibit increased ignition efficiency and contribute positively towards combustion instabilities and undesired emissions.

BACKGROUND ON NANOTUBE IGNITION

Ajayan, et al. [4] were first to report that as-produced single-walled carbon nanotubes (SWCNTs) ignite when subjected to a common photographic flash at a close range. This effect was observed for dry, "fluffy" SWCNTs and was diminished somewhat for compacted material. Ignition did not occur for similar materials such as multi-walled carbon nanotubes (MWCNTs), graphite powder, fluffy carbon soot, and C₆₀. The observed structural changes in the SWCNTs during an ignition process indicated a temperature in excess of 1500°C. Ajayan et al. [4] explained this process through generation of a heat pulse, created through light absorption by the nanotubes, combined with inefficient heat dissipation due to the structure of the nanotubes. Braidy et al. [5] confirmed the flash ignition effect on SWCNTs but also reported the presence of iron oxide particles in the combustion byproducts. These were reported to be predominantly Fe₂O₃ with a small amount of Fe₃O₄. The diameters of these oxide particles varied depending on their proximity to the nanotube bundles. Particles within the bundles ranged from 15 to 20 nm in diameter, while free-standing fused grains, which were not enclosed by nanotube bundles, ranged from 15 to 50 nm in diameter. The electron energy loss spectroscopy (EELS) was used to show that both types were indeed Fe₂O₃. Both morphology types were considerably larger than the nanoparticles of Fe in the pristine SWCNTs, which were 1-5 nm in diameter.

Smits et al. [6] conducted experiments to determine the cause for ignition of the SWCNTs. They tested three different samples: (a) as-produced SWCNTs synthesized by the HiPco process (from Carbon Nanotechnologies Inc.), (b) the same material obtained but after a purification process, and (c) 99.5% pure, 6 -10 μm diameter Fe powder. All three samples were subjected to identical flash lighting and subsequently micro analyzed. When flashed, both the as-produced SWCNTs and the Fe powder ignited, while the purified SWCNTs showed no reaction. Burning of the unpurified SWCNTs and Fe powder occurred slowly in small, localized locations, giving off a faint red-orange glow. The burning spread slowly, typically lasting 1-3 s before dying out. Burning of the Fe powder could be extended to several seconds by physical agitation. Examination of the nanotube samples by unaided eyes revealed relatively large clusters of hardened, orange material in the burned areas. TEM analysis of the as-produced nanotube samples before burning revealed large quantities of Fe nanoparticles 3-8 nm in diameter. The Fe particles appear to be contained within the nanotube bundles and along their exterior surfaces. After flashing the as-produced SWCNTs, the Fe nanoparticles changed from evenly-distributed throughout the sample to large clusters of particles with substantially increased diameters. The particle sizes after burning has increased from 3 to 8 nm in diameter to well over 100 nm. The structure of SWCNTs had been altered by exposure to high temperature and their diameters were no longer uniform. The large increase in particle size suggests that the Fe particles melted and coalesced which imply temperatures in excess of the melting point of Fe, or 1538°C. It seems that radiant energy transfer from the flash to the SWCNTs and the Fe nanoparticles causes different responses, and it is likely that the heat dissipates in the highly conductive and interconnected CNT bundles whereas it is almost entrapped locally in the Fe nanoparticles. The nanoparticles are also encapsulated in carbon atom layers which may serve to insulate the Fe. Catalytic Fe nanoparticles, created during the SWCNT synthesis process, with sizes on the order of those found in the as-produced SWCNTs are highly pyrophoric with a propensity to spontaneously ignite in the presence of oxygen, resulting in oxides of iron (Fe_2O_3 and Fe_2O_4). Bare Fe nanoparticles observed on the exterior surfaces of the SWCNT bundles are most susceptible to oxidation. Sub-surface Fe nanoparticles are likely to be involved in the oxidation process as well. Chiang et al. [7] describe that the carbon shells are known to be permeable to oxygen and allow oxidation of Fe nanoparticles.

The first step in the purification of SWCNTs involves the oxidation of encapsulated Fe nanoparticles. The remaining Fe nanoparticles left after the purification process are less likely to oxidize during flash exposure. Smits et al.³ found that the exothermic oxidation of Fe released sufficient heat to cause melting, coalescence and oxidation of nanoparticles, which caused aggregation into clusters of large particles. The heat released during the oxidation is sufficient to promote transformations within the adjacent SWCNTs, including fusing some SWCNTs into larger tubes. This indicates temperatures in excess of 1500 °C. Iron melts at 1538 °C and the fully-oxidized Fe_2O_3 compound decomposes at 1565 °C, which is likely the temperature range of the reaction. In addition to structural modifications of the SWCNTs during the ignition and combustion processes, some material is reduced to an amorphous state. Amorphous carbon coatings are found on most of the Fe_2O_3 particles. These may have condensed on the surface of the Fe_2O_3 particles during cooling of the oxide particles. Smits et al. [6] believe that the flash ignition of SWCNTs should be attributed to the pyrophoric nature of fine Fe particles within the nanotube bundles, rather than to any property of the SWCNTs themselves. However, the SWCNTs are believed to provide a medium stabilizing these nanoparticles to prevent spontaneous initiation of ignition until they are exposed to an appropriate stimulus such as energy from an ordinary camera flash.

RESULTS AND DISCUSSION

We have used the observation that SWCNTs embedded with Fe nanoparticles can be ignited with a flash of light to develop an ignition method that is capable of igniting liquid hydrocarbons (RP-1 and methanol), monopropellants (nitro methane), ionic liquids (HEHN), HAN based fuels and solids (Potassium-Chlorate (KClO_3) and wax paper), see Danczyk and Chehroudi [8]. A U.S. patent has already been applied for by Chehroudi et al. [9] and is pending.

A small amount (a fraction of a milligram) of SWCNTs along with a few drops of fuel could be ignited with a camera flash placed a few millimeters above the SWCNTs. The camera flash would ignite the SWCNTs in multiple locations and the heat released by the oxidation of Fe nanoparticles would ignite the fuel. As the fuel burned off, more of the SWCNTs would ignite until the entire fuel was consumed. The fuel would usually burn off much faster than the SWCNTs. As the SWCNTs burned, there appeared a faint glow in the areas where it ignited first and the mixture would turn from its initial black to an orange in color. What remained after the end of the combustion process was a much denser and harder mixture.

To have a successful ignition, the SWCNTs had to be arranged in a "fluffy" pile and as the ignition sites moved from one location to another, one could observe the pile collapsing on itself. Ignition did not occur if the pile of SWCNTs were compacted before being exposed to a flash light. There is no reason to believe that the metal oxides which remained in our tests are any different than what Brady et al.² and Smits et al. [6] described. The orange-colored material is most likely iron oxides Fe_2O_3 and Fe_2O_4 . The iron oxide particles that remained after our combustion were much larger than any particles that were in the initial

mixture. This reinforces the observation by Smits et al. [6] that the Fe particles melted and coalesced as the oxidation continued. Since the nanosized Fe particles are pyrophoric, it is believed that the SWCNTs must stabilize the Fe particles as mentioned before. What has not yet been determined is the mechanism by which the flash either damages the SWCNTs, exposing the Fe particles to the oxygen, or somehow makes the Fe particles more reactive. We have found that the SWCNTs were only able to ignite the fuels when they were in contact with the air or immersed in an oxygen-rich environment. The SWCNTs did not ignite the fuels if they were completely submerged in liquid fuels. If they were submerged completely, then only when the liquid fuel was allowed to vaporize and consequently expose the SWCNTs to sufficient oxygen, was the mixture able to be ignited with a flash.

Figure 1 shows a typical mixture of SWCNTs and a few drops of fuel before ignition and during the combustion of the fuel. In these tests we have used fuels that considered difficult to ignite. Gasoline was comfortably ignited. The tube to the left of the image is flowing pure oxygen over the SWCNTs creating an oxygen-rich environment to help reliably ignite the mixture. The oxygen was needed due to the low concentration of Fe in the purified SWCNTs. Higher concentrations do not require enrichment. Ionic liquids have historically been ignited using a catalyst and it has been difficult to sustain the combustion process. In this case the fuel was easily ignited by the SWCNTs and it was completely consumed during the combustion process. The flame from the fuel would move and stay attached to the location where the nanotubes were burning. This observation was unique to the ignition of HEHN because fuels such as RP-1 appeared to ignite and then burn like a diffusion flame until the fuel was fully consumed, whereas the HEHN seemed to be relying on the energy released from the Fe combustion to sustain the combustion process. The ignition of the HAN-based fuel was also unique in that the monopropellant would be ignited but the flame would quickly be extinguished without consuming all of the fuel. The mixture of nanotubes and this fuel could be re-exposed to the flash of light and the fuel would re-ignite. This process could be repeated until the fuel was completely consumed. Other fuels tested would usually be consumed completely and the Fe in the SWCNTs in the process. The HAN-based fuel would seem to burn just enough fuel out of the mixture to expose more nanotubes to the oxygen rich environment but quenching the Fe combustion which could be re-ignited with another exposure to a flash of light. Even with dry SWCNTs, the pile would have to be agitated or mixed to re-ignite any remaining Fe if the initial ignition did not oxidize it all. But with a HAN-based fuel it could be re-ignited without agitation.

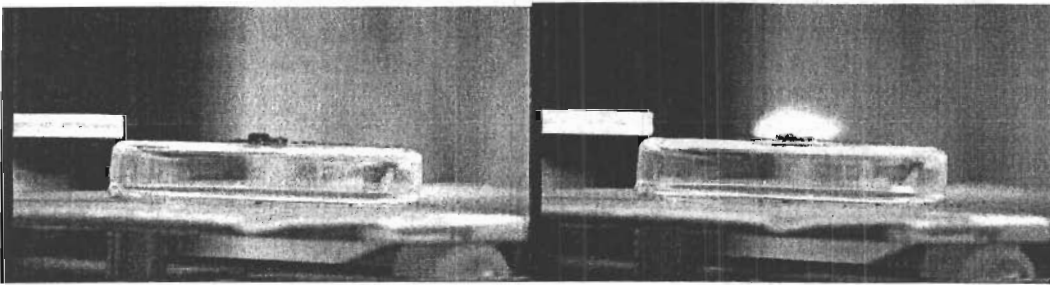

Figure 1. SWCNTs and a few drops of HEHN before and during combustion.

The effects of the concentration of the Fe nanoparticles on the ignition process were also studied. As-produced (or unpurified) SWCNTs synthesized by the HiPco process (from Carbon Nanotechnologies Inc.) have a Fe concentration of approximately 30% by weight. These SWCNTs are very “fluffy” and reliably ignite in atmospheric air using a camera flash. Carbon Nanotechnologies Inc., also purified SWCNTs to an Fe concentration of approximately 3% by weight. Samples of these SWCNTs were much less “fluffy” than the as-produced SWCNTs. The unpurified SWCNTs occupied approximately five times the volume of the purified SWCNTs. To reliably ignite the purified SWCNTs, they had to be exposed to an oxygen-rich environment. In this case, a small amount of oxygen was blown over the sample while it was flashed. However, if the SWCNTs were purified once more to a Fe concentration of 1.5% by weight, the SWCNTs would not ignite even in an oxygen-rich environment.

The smallest amount of SWCNTs needed to reliably ignite the fuels tested here has not been established yet. In this preliminary study, we have focused on using amounts that could reasonably be assumed to exist in a single large droplet (approximately 100 μm). It is believed that as the embedded Fe concentration in the sample is increased, the amount of SWCNTs can be decreased. It has been observed that when flashing SWCNT samples for ignition without the fuel, only a very small amount of SWCNTs are needed. These amounts are hardly visible to the naked eye and it is not unreasonable to assume that the SWCNTs could be agglomerated in such a way to minimize the amount of SWCNTs needed to reliably initiate ignition. A primary focus of this work is to develop a distributed ignition method for engine applications using liquid fuel sprays. As a preliminary study, the goal was to ignite a suspended single droplet of a liquid fuel. The nanotubes in a single droplet behaved much differently than the previous studies where the a few drops of a given fuel were added to a small amount of nanotubes on a flat surface. In the droplet

case, the nanotubes would separate and fill the entire droplet. As previously stated, to achieve ignition the nanotubes need to be in loose contact with each other and in contact with oxygen, but this was not the case with the nanotubes in the droplet. As a droplet evaporates and becomes smaller in size, the nanotubes would come in close contact, especially near the surface of the droplet, and once again are exposed to the oxygen. Some amount of SWCNTs may even be expelled out with vaporized fuel as a result of the evaporation process. At this point, the Fe in the nanotubes may find sufficient oxygen for light-induced ignition thereby igniting the vaporizing droplet. In a practical liquid fuel spray, this process could lead into multiple droplet ignition and consequently to light-initiated spray ignition. Figure 2 shows an attempt to simulate single-droplet ignition by a different system that could also be used to ignite a liquid fuel spray. In this case, the nanotubes would be added to the oxidizer instead of mixing with a liquid fuel. The nanotubes are bound together by an epoxy and, if correctly manufactured, can be easily ignited. The first image shows the nanotubes attached at the tip of a needle with a droplet of fuel hanging off a syringe. The second image shows the ignition of the nanotubes, also igniting the epoxy. The third image shows the droplet ignited and burning. This was enabled due to the close proximity of the droplet to the nanotubes. This could be expanded to a spray where there would be an initial mixture of the nanotubes in the oxidizer and the fuel mixed throughout the spray which could then be ignited. After the spray is ignited, the injection of the nanotubes would no longer be needed.

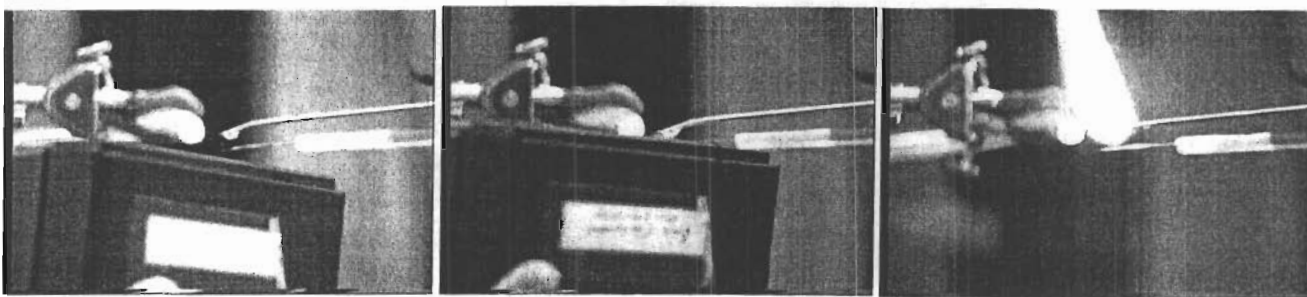

Figure 2. Ignition of a single droplet.

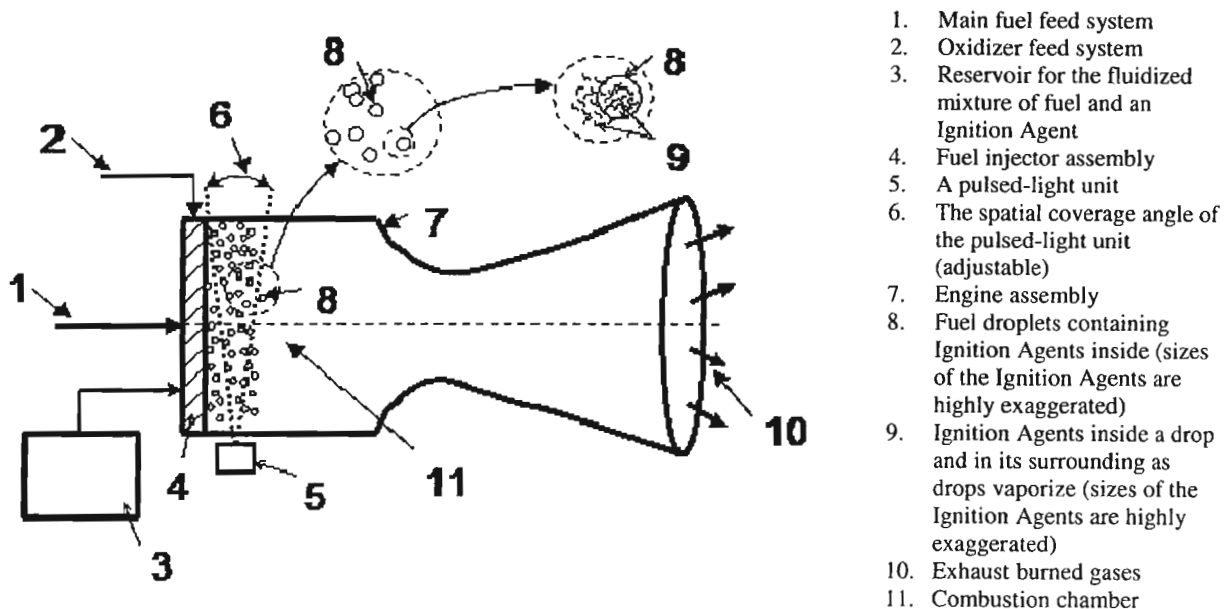

Figure 3 Schematic diagram showing an application of the SWCNTs as ignition agents for the ignition process in a liquid rocket engine combustion chamber (drawing not to scale).

Figure 3 shows a concept ignition system for a class of liquid rocket engines using SWCNTs and a short-duration light source. The SWCNTs as ignition agents would be mixed with the fuel and as the mixture atomized, forming droplets and vaporized, the SWCNTs would be exposed to the oxidizer which can then be ignited with the light source. This technique could offer the ability to produce distributed ignition with multiple droplets being ignited throughout the light-exposed volume (or plane if a laser sheet is used). The expanded views in the inset show the individual droplets containing SWCNTs vaporized to a sufficient level where they leave SWCNTs free to have full contact with oxidizer molecules and be ignited upon light flashes. The SWCNTs could also be injected into or fluidized with the oxidizer which would eliminate the need for droplet vaporization necessary in the previous method to expose the SWCNTs to oxidizer molecules.

Figure 4 shows a conceptual implementation of distributed ignition using SWCNTs (or any other nonstructured material possessing similar ignition properties). SWCNTs as ignition agents can be either fluidized with air in the intake system or mixed in the fuel. Once the fuel is vaporized and reasonably mixed with air (as oxidizer) then SWCNTs are assumed distributed throughout the combustion chamber. This arrangement could be an SI engine or a HCCI engine. However, in an HCCI engine, a controlled distributed ignition is desirable and currently a subject of intense research, see Chehroudi [2]. This can be achieved by activation of a pulsed light source with a suitable spatial coverage as shown in Fig. 4. At this stage, we are only considering the potential of this new method for distributed ignition and economical factors, which can drastically change with efficient production technologies in time, are not considered as part of the equation.

There are a number of important payoffs in developing such an ignition system. With regard to rocket propulsion, it is thought that nearly 30% of the combustion instabilities, leading to engine damages and possible loss of cargo and human life, can be traced to the nature of the propellant ignition process, see Harrje and Reardon [10]. There are indications that a distributed nanoignition method, easily tuned spatially through a suitable choice of light source and optics, may provide a lower incidence of ignition-induced combustion instability events. Demonstration of the ability to ignite a fuel spray using a nanostructured material is a critical step in advancing this ignition method to a stage where it could be applied to real world engines.

It is envisioned that this novel ignition method be used for realization of selective multi-point and/or distributed ignition in liquid fuel sprays (used in most rockets and other engines) and future advanced ground-based vehicles, operating based on a HCCI approach, for effective and efficient startup or relight operation, see Bieber [11]. The ability to select and continuously vary the ignition locations or regions in an engine, as a control parameter (distributed ignition), is a critical and useful engineering design

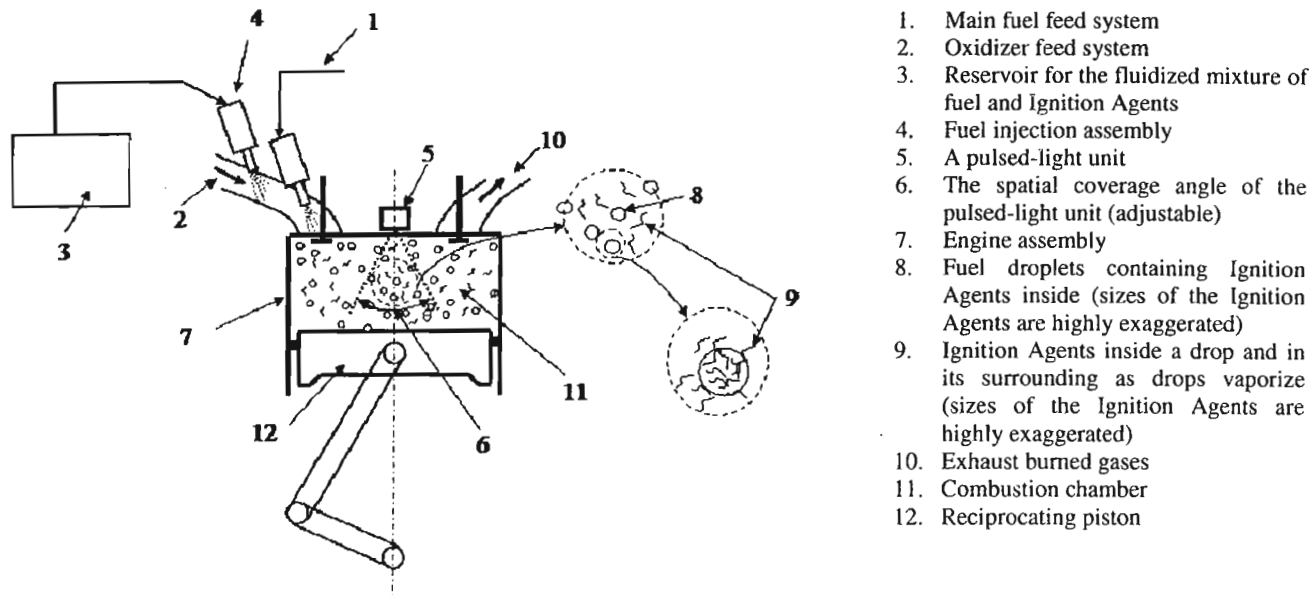

Figure 4 Schematic diagram showing an application of the SWCNTs as ignition agents for the ignition process in a reciprocating combustion engine (drawing not to scale).

component for developing high-efficiency combustion chambers in most modern engines. Distributed ignition may also be a solution to the problem of monopropellant (rocket) ignition. The use of nanostructured materials (such as SWCNTs or other similar candidates) as ignition agents also has the advantage of requiring fewer components and less energy than current ignition methods. This leads to a reduction in overall flight weight and an increased applicability to emerging technologies such as micro- or nano-satellites. Prevention of inadvertent ignition in some applications is a critical part of a safe operating procedure. For example, some rocket engines have electrically-initiated pyrotechnic devices, such as pyro-valves, pyro-bolts, and shroud cutters, that could accidentally be set off by electrical noise. Select nano-structured materials or their mixtures with a poor explosive material could be used as a target for a low-power laser (or diode lasers) to optically initiate the ignition process. Also, explosive actuators, used in jettison systems for missile separation stages, aircraft emergency escape chute and airbags, are typically ignited through the use of a hot bridgewire. Inadvertent ignition of an electrical explosive actuator can never be ruled out. When actuators are deployed in noisy electrical environments, it is necessary to incorporate features to reduce the threat of spurious electrical signals. The electrical power requirements of laser diodes are comparable to those of electrical explosive actuators but have the advantage that they are invulnerable to spurious electrical signals by incorporating them into the firing control system which includes suitable protective features.

FUTURE WORK

A fundamental understanding of the observed SWCNTs ignition phenomenon described above is required in order to engineer an efficient nanostructured ignition agent for fuels. At this stage, several experiments are envisaged to assist basic understanding of this new ignition method. A series of tests are proposed to investigate effects of the light wavelength and power level on dry nanotubes (unmixed with any fuels) carrying different percentages of Fe nanoparticles. This should provide a power threshold level and the most effective wavelength range for the ignition process. These experiments can be repeated with different fuels to see if they affect the power threshold. Fast spectroscopy of the light emitted as well as ultra high-speed movies just after initiation of a short-duration light source are proposed and considered critical to providing information on some of the ignition dynamics. This is needed to determine exactly how this new ignition process occurs. Some of the questions are whether Fe nanoparticles ignite and damage the nanotubes or the nanotubes are damaged allowing the nanoparticles to ignite. It is also important to ascertain the minimum amount of nanotubes needed to enable ignition. With regard to the nanotubes' demonstrated ability to ignite liquid fuels, a flow facility is to be used to generate a single droplet loaded with various amounts of nanotubes with different percentages of Fe nanoparticles. The purpose is to investigate fuel drop vaporization, light-induced ignition, and spectroscopic signature at selected locations in the flow reactor. It is thought that as the liquid is vaporized, nanotubes that are positioned at the surface of the drops or those ejected by the fuel vaporization process near the interface, should bring about ignition upon short-duration light exposure. The concentration of oxygen molecules in the flowing stream will also be varied. Computer simulation of the drop history in the flow facility and modeling of the impact of the nanotubes inside the drop and the optimum location of the light-induced ignition are to be predicted and compared with the experimental results. Also, analysis of the characteristic differences between ignition of dry nanotubes (carrying different percentages of Fe nanoparticles) and those of Fe particles of different scales, from micrometer in averaged diameter extending to the smallest stable size, is thought to be quite informative. In this test, effects of light wavelength and power should also be considered. Additionally, spray ignition of selected liquid fuels including monopropellants is proposed using an ultrasonic atomizer. This atomizer has the capability of producing fine droplets carrying nanotubes or mixing the fuel-only spray with a coaxial shaping air fluidized with nanotubes. Results of this test should facilitate implementation of this new method of ignition in practical liquid-fueled rocket engines. The possibility of impregnating the nanotubes with oxygen molecules is to be investigated. This could be a method to enhance the ignition ability of the nanotubes under conditions where sufficient oxygen may not be available for effective ignition such as when they are fully immersed in liquid fuels. Finally, a computer simulation and/or theoretical investigation on the nature of interaction between a short-duration light and candidate nanostructured materials is considered valuable in shining light on the mechanism of this ignition process.

CONCLUSIONS

It has been demonstrated that SWCNTs as ignition agents and an ordinary camera flash can be used as an ignition source for a variety of fuels. It is believed that the Fe nanoparticles in the SWCNTs are the entities actually ignited by the flash and the burning of these Fe particles lead into the ignition of the fuels. As-produced SWCNTs with Fe concentrations of 30% by weight are reliably ignited in atmospheric air. As the Fe concentration is reduced to approximately 3% by weight, the SWCNTs must be in an oxygen-rich environment to reliably ignite. If the Fe concentration is reduced to 1.5% by weight, the SWCNTs can no longer be ignited. The exact mechanism which causes the camera flash to ignite the Fe particles embedded in SWCNTs has not yet been determined. Once this mechanism is clarified, it is believed that we will be in better position to customize the SWCNTs intelligently to produce

the desired ignition. Industrial applications were briefly explained which show the exciting potential of this extremely-low-input-energy nano-technology based new ignition technology in aerospace (rockets and satellites) and automotive (HCCI) engines.

REFERENCES

1. Heywood, J. B., Internal combustion engine fundamentals, McGraw-Hill Science/Engineering/Math; 1st edition , April 1, 1988.
2. Chehroudi, B., Homogeneous charge compression ignition (HCCI) engine, Powertrain International, Vol. 5, No.1, pp. 6-10, 2002.
3. Dale, J. D. and Oppenheim, A. K., Enhanced ignition for I.C. engines with premixed gases, SAE Transaction paper 810146, 1981.
4. Ajayan, P.M., Terrones, M., de la Guardia, A., Hue, V., Grobert, N., Wei, B.Q., Lezec, H., Ramanath, G., Ebbesen, T.W., Nanotubes in a Flash-Ignition and Reconstruction, *Science*, 296, 705 (2002)
5. Braidy, N, Botton, G. A., and Adronov, A., Oxidation of Fe Nanoparticles Embedded in Single-Walled Carbon Nanotubes by Exposure to a Bright Flash of White Light, *Nano Letters*, 2, 1277 (2002).
6. Smits, J., Wincheski, B., Namkung, M., Crooks, R., Louise, R., *Material Science and Engineering A358*, 384 –389, 2003.
7. Chiang, I.W., Brinson, B.E., Huang, A.Y., Willis, P.A., Bronikowski, M.J., Margrave, J.L., Smalley, R.E., Hauge, R.H., Purification and Characterization of Single-Wall Carbon Nanotubes (SWNTs) Obtained from the Gas-Phase Decomposition of CO (HiPco Process) *J. Phys. Chem. B* 105(35), 8297 – 8301, 2001.
8. Danczyk, S. C. and Chehroudi, B., An innovative ignition method using SWCNTs and a camera flash, 2005 Nano Science and Technology Institute (NSTI), Nanotechnology Conference and Trade Show, Anaheim, California, May 8-12.
9. Chehroudi, B., Vaghjiani, G. L., and Ketsdever, A. Method for distributed ignition of fuels by low-energy light sources, United States Patent Office, Patent Pending, 2004.
10. Harrje, D. T. and Reardon, F. H. Liquid propellant rocket combustion instability, NASA SP-194, Scientific and Technical Information Office, Washington, D. C., 1972.
11. Biever, C., "Forget Spark Plugs, Start Your Engine with Nanotube," coverage of the nanotube ignition work by the *New Scientist Magazine*, Nov 19, 2005.