

12 SEP 1968

UNCLASSIFIED

~~CONFIDENTIAL~~

AWRE E2/68

~~DISCREET~~

Copy No 55

Decl OADR

PD-4550

AWRE E2/68



PROTHERO SYSTEMS
SCIENTIFIC AND MEDICAL DEPARTMENT

20071109081

UNITED KINGDOM ATOMIC ENERGY AUTHORITY

AWRE REPORT No. E2/68

The Effect of Light Casings on the Blast Parameters from a
Spherical Charge of RDX/TNT 60/40

Valerie J. Bishop

D. J. James

INV 90

"This document contains information affecting the National
Defense of the United States within the meaning of the
Espionage Laws, Title 18, U. S. C., Sections 793 and 794.
Its transmission or the revelation of its contents in any
manner to an unauthorized person is prohibited by law."

DISTRIBUTION STATEMENT A
Approved for Public Release
Distribution Unlimited

~~CONFIDENTIAL~~

~~DISCREET~~

AWRE,
Aldermaston, Berks.

May 1968

Req 115448

Hg-48

UNCLASSIFIED

(C)
C 131717
(55)

UNCLASSIFIED

THIS DOCUMENT IS THE PROPERTY OF THE U.K. ATOMIC ENERGY AUTHORITY
AND ATTENTION IS CALLED TO THE PENALTIES ATTACHING
TO ANY INFRINGEMENT OF THE OFFICIAL SECRETS ACTS

It is intended for the use of the recipient only, and for communication to such officers under him as may require to be acquainted with its contents in the course of their duties. The officers exercising this power of communication are responsible that such information is imparted with due caution and reserve.

Any person other than the authorised holder, upon obtaining possession of this document, by finding or otherwise, should forward it together with his name and address in a closed envelope to:—

THE DIRECTOR, ATOMIC WEAPONS RESEARCH ESTABLISHMENT,
ALDERMASTON, BERKSHIRE.

Letter postage need not be Prepaid, other postage will be refunded. All persons are hereby warned that the unauthorised retention or destruction of this document is an offence against the Official Secrets Acts.

SUBJECTS

- I. COVERINGS.
- II. EXPLOSIVE CHARGES.
- III. BLAST EFFECTS.

IV.

V.

ADDED ENTRIES

- I. BISHOP, V. J.
- II. SHORT TITLE: TEOLCOT.
- III. UNITED KINGDOM.

IV

V. Project No.

VI. Contract No.

UNCLASSIFIED

UNCLASSIFIED

~~CONFIDENTIAL DISCREET~~

2
United Kingdom Atomic Energy Authority, U.K.,

AWRE, Aldermaston

6
AWRE REPORT NO. E2/68

3. CLASSIFIED TITLES.

The Effect of Light Casings on the Blast Parameters from a
Spherical Charge of RDX/TNT 60/40

4
Valerie J. Bishop, et al,
D.J. James

(Work carried out for RARDE under Contract No. MINTECH KV/B/431.)

Recommended for issue by

D.E.J. Samuels, Superintendent

Approved by

N.S. Thumpston, Senior Superintendent

623.565.23:662.2-3(RDX/TNT)
662.2-3(RDX/TNT):623.565.23

DISTRIBUTION STATEMENT A
Approved for Public Release
Distribution Unlimited

1
~~CONFIDENTIAL DISCREET~~

UNCLASSIFIED

UNCLASSIFIED

~~CONFIDENTIAL DISCREET~~

TABLE OF CONTENTS

	<u>PAGE</u>
SUMMARY	3
1. INTRODUCTION	3
2. OBJECT OF THE EXPERIMENTS	4
3. EXPERIMENTAL DETAILS	4
3.1 Charges	4
3.2 Layout	4
3.3 Recording Equipment	4
3.4 Firing Schedule	5
4. PIEZO-ELECTRIC GAUGE RESULTS	5
5. HIGH SPEED CINE CAMERA RESULTS	5
5.1 Aluminium Cased Charges	6
5.2 Lead Cased Charges	6
5.3 Magnesium Cased Charges	6
5.4 Steel Cased Charge	7
6. DISCUSSION	7
6.1 Aluminium Cased Charges	7
6.2 Lead Cased Charges	7
6.3 Magnesium Cased Charges	8
6.4 Steel Cased Charge	9
7. COMPARISON WITH OTHER WORK	9
7.1 Blast Parameters	9
7.2 Fragment Velocities	9
8. CONCLUSIONS	10
9. RECOMMENDATIONS	10
10. ACKNOWLEDGEMENT	11
REFERENCES	12
TABLES 1 - 3	13
FIGURES 1 - 14	16

~~CONFIDENTIAL DISCREET~~

UNCLASSIFIED

SUMMARY

The report examines the blast wave parameters obtained from an 8 lb spherical charge of RDX/TNT cased in aluminium, lead, magnesium or steel. Three different case thicknesses of aluminium were examined, two of lead, two of magnesium and one of steel. The shock wave profile was recorded with side-on piezo-electric pressure gauges placed between 4 and 20 ft away from the charge. High speed cine films were taken of the fireball growth.

Peak overpressure and impulse enhancement over the values from an uncased RDX/TNT charge were obtained only from the thickest lead casing. All the aluminium, magnesium and steel casings gave a reduction in pressure except at the furthest distance from the charge. The thinnest casings of aluminium, lead and magnesium all produced impulses of the same value as those from an uncased charge.

1. INTRODUCTION

The present work, carried out under an RARDE contract, was designed to see if there was an enhancement of blast parameters from lightly cased charges compared with the parameters from the same mass of explosive uncased.

Very little work has been done in the past on the effect of light casing on the blast parameters from spherical charges. Dewey, Johnson and Patterson [1] have investigated the effect of light powder surrounds and casings on the blast parameters from Pentolite and HBX - 6 explosives. Among the surrounds and casings employed were aluminium powder, cast aluminium and magnesium and stainless steel. The charges, which were spherical, ranged between 2 oz and 1 lb in weight and they were fired both at atmospheric and reduced pressures. Normally reflected impulses were measured with piezo-electric gauges. The results of these experiments showed that surrounds of aluminium powder gave the largest increase in reflected impulse close to the charge and increases in peak pressure and reflected impulse at all distances. Spun steel casings reduced the reflected impulses at atmospheric pressure. At reduced ambient pressures all casings gave increased reflected impulses. Cast aluminium and magnesium casings increased the reflected impulse at reduced pressure more than an equal mass of explosive and did not reduce the reflected impulse at atmospheric pressure.

RARDE requested the measurement of blast parameters over the range from 100 - 10 psi from RDX/TNT charges cased in shells of aluminium, lead, magnesium and steel of various thicknesses. Measurements of the casing fragment velocity were also made.

CONFIDENTIAL DISCREET

2. OBJECT OF THE EXPERIMENTS

- (a) To determine whether there is an enhancement of air blast when a high explosive charge is clad with a thin metallic shell.
- (b) To measure the fragment velocities of the various metallic shells.

3. EXPERIMENTAL DETAILS

3.1 Charges

The charges, which were supplied by RARDE, each consisted of a machined sphere of RDX/TNT 60/40 nominally 8 lb in weight, drilled to its centre to take a No. 8 electric detonator. The charge was surrounded by a metal case which was made in two hemispheres with a half inch radius semicircle cut out of each hemisphere so as to leave the detonator hole clear (see Figure 1).

3.2 Layout

It was necessary to fire the charges at a minimum height of 17 ft from the ground in order to ensure that reflections from the ground would not be superimposed on the positive phase of the blast wave profiles. The charge was suspended in a string net between two masts at a height of 25 ft above the ground. This height was chosen as 20 ft masts were readily available on which to mount the blast wave recording gauges. Guys were attached to a wooden cross from which the net was suspended (see Figure 2) so that the charge could be arranged to have the seam of the metal casing at right angles to the blast gauges. This is to ensure that any enhancement of parameters measured could not be due to possible jetting at the seam.

3.3 Recording Equipment

The hydrostatic overpressure in the shock wave was recorded by quartz piezo-electric transducers with B12 type omnidirectional baffles. These gauges were mounted along a horizontal line, with their sensitive surface at the same height as the charge centre. The distances varied from approximately 4 to 20 ft. A dummy gauge was erected 2 ft in front of the first gauge in order to deflect the fragments, keeping the damage sustained by the first gauges to a minimum. Measurements were obtained from eight of these B12 type gauges for each charge fired.

The gauges were connected to Southern Instruments Mini-rack recording equipment and the signals obtained were photographed by rotating drum cameras. The gauge cables had to be well protected from the effects of blast and fragments on firing. Since the cable protection was within several feet of the gauges it was streamlined, in order not to distort the records obtained. Figure 3 shows the experimental gauge positions. The distance from the charge centre to the centre of each gauge was determined from a photograph taken immediately before firing. The measurements were made from a 12 in. x 10 in. enlargement printed on Kodak Bromide Foil Card. The gauge baffle diameters were used to calibrate distance.

CONFIDENTIAL DISCREET

A 16 mm Fastex high speed cine camera was used to film the fireball and its growth, in colour. The camera was run at approximately 12000 half frames per second.

3.4 Firing Schedule

Table 1 lists the charges fired during these experiments. The first firing was an uncased charge of RDX/TNT. The shock wave parameters that were obtained from this firing were compared with those from each of the cased rounds. These consisted of aluminium casings of 0.250, 0.548 and 0.786 in. thickness, two lead casings of 0.078 and 0.218 in. thickness (two rounds were fired of the latter thickness due to recording difficulties on the first shot), two thicknesses of magnesium, 0.437 and 0.788 in. and one steel casing of 0.105 in.

4. PIEZO-ELECTRIC GAUGE RESULTS

Since the object of the experiments was to determine if there was any enhancement of blast parameters due to casing a spherical bare charge with a metallic shell, the blast parameter-distance graphs are therefore presented in which comparison is made between:-

(a) Peak overpressure for a cased charge and for the same charge mass uncased (see Figures 4 - 7).

(b) Positive impulse intensity for a cased charge and for the same charge mass uncased (see Figure 8).

The above two parameters are those primarily concerned in considerations of target damage. Similar comparisons are also made for the positive duration (Figure 9).

The results are summarised in Table 2.

5. HIGH SPEED CINE CAMERA RESULTS

A high speed cine colour film was obtained of the fireball growth for each round fired. An example is shown in Figure 10 which is a black and white reproduction of frames from the magnesium cased charge (0.788 in. thick) film. From Figure 10 it can be seen that in the initial stages the fireball is spherical in shape but after about 0.5 ms it begins to take on a "spikey" appearance. The spikes are the luminous fragments of the casing which surrounded the charge. The luminous aluminium and magnesium fragments showed up clearly in the cine films, they were a bright yellow-white colour. The smaller fragments from the steel cased charge were not so distinct and were a dark yellow-orange shade. For all the lead cased charges the fireball after its initial white appearance during the first 0.5 ms after detonation, soon changed to a dark greyish orange colour. There were no luminous fragments such as were obtained from the other three casing materials but the fireball did have a slightly spikey shape. In assessing the fireball growth from the colour films the leading

edge of the fireball was measured on each frame. Since in the later stages of the fireball growth the leading edge was composed of the spikes of the luminous casing fragments the plot of fireball growth with time can be used to determine the fragment velocity at any point. The fireball growth curves for the four types of metal casing are given in Figures 11 - 14. The fragment velocities calculated from these curves are shown in Table 3.

5.1 Aluminium Cased Charges

The fireball growth curves for the three thicknesses of aluminium are shown in Figure 11. From this graph can be seen that the thinner the casing thickness the faster the rate of fireball growth and consequently the higher the initial fragment velocity. Also plotted in Figure 11 for comparison is the fireball growth curve obtained from the uncased RDX/TNT charge. Initially, because it is unrestrained by a casing, the uncased RDX/TNT charge fireball expands more rapidly but after 0.4 ms its velocity is decreasing rapidly compared with that of the cased charges.

The first 400 μ s of the cased charge curves are very nearly straight lines consequently it is possible to determine the fragment velocity for each of the case thicknesses over this portion of the growth from the slope of the line. The velocity of the 0.250 in. aluminium case fragments is 9400 ft/s and for the 0.548 and 0.786 in thick cases the velocities are 7700 and 7200 ft/s respectively. At 6 ft from the charge centre the velocity of the heaviest casing fragments had dropped to 5600 ft/s while the velocities of the 0.250 and 0.548 in. case fragments had become 7400 and 7000 ft/s respectively.

5.2 Lead Cased Charges

Figure 12 shows the plot of fireball growth for the lead cased charges. As for the aluminium cased charges the thinner lead casing produced the faster fireball growth. The shape of the lead cased charge curves however are more like that of the uncased RDX/TNT charge which is shown as a dotted line in Figure 12. There is a much more rapid drop in velocity of the fireball growth for the lead casings compared with those from the aluminium. The colour films of the lead cased firing showed that the fireball remained spherical during the whole of its measured growth. There were no luminous fragments visible, as spikes, as there were with the aluminium cased charges. This coupled with the fact that no lead fragments were found in the vicinity of the layout after the firing leads one to conclude that both lead case thicknesses were completely vapourised by the explosion. The lead fireball growth curves are practically straight over the first 250 μ s and a calculation of velocity over this period gives values of 9100 and 7400 ft/s for the 0.078 and 0.218 in. thick cases respectively. At 6 ft from the charge centre the velocities had dropped to 2800 and 2500 ft/s.

5.3 Magnesium Cased Charges

The plot of fireball growth with time for the 0.437 and 0.788 in. thick magnesium case charges are given in Figure 13. Here again the

lighter cased charge produced the largest fireball growth. The average velocity of the thinner casing over the first 400 μ s was 8600 ft/s while that of the thicker case was 7700 ft/s. At 6 ft from the charge centre the velocity of the thinner case has decreased very little being 8000 ft/s while that of the thicker case has become 5800 ft/s.

5.4 Steel Cased Charge

The fireball growth obtained from the single firing of a steel cased charge is shown in Figure 14. The fireball behaviour is similar to that from the thinnest aluminium and magnesium cases. The velocity of the fragments over the first 400 μ s is 8600 ft/s, at 6 ft this decreases only slightly being 8100 ft/s.

6. DISCUSSION

6.1 Aluminium Cased Charges

Examination of Figures 4, 8(a) and 9(a) shows that although the 0.548 in. thick aluminium casing gave the smallest reduction in peak overpressure nearest the charge compared with the uncased RDX/TNT charges it produced the largest reduction in positive duration. The 0.786 in. case gave the lowest peak overpressures but the durations from this charge were similar to those from the thinnest casing.

Figure 8(a) showed that the positive impulses decreased with increasing case thickness. From the impulse results there is an indication that a casing thinner than 0.250 in. might produce an impulse enhancement over the uncased charge results. However the effect of a case < 0.250 in. thick on the peak overpressures and durations cannot be deduced from the results obtained so far.

The fireball growth curves in Figure 11 suggest that a casing less than 0.250 in. thick would give a faster fireball growth than any so far obtained, this in turn would mean higher fragment velocities.

6.2 Lead Cased Charges

From Figures 5, 8(b) and 9(b) it can be seen that the 0.078 in. thick lead shell had very little effect on the blast parameters. The peak overpressures and positive impulses are almost identical to those from the uncased RDX/TNT charge over the range recorded. The positive durations were reduced by 10% at the closer in distances to the charge but this reduction is barely significant as the standard deviation of the curves is \pm 5%.

For the 0.218 in. thick case however there was an average enhancement of 30% on peak pressure and 15% on positive impulse. The durations at the nearest distances to the charge were reduced by 25% but further out they were the same as the uncased charge. The enhancement in peak pressures and positive impulses is probably due to a combination of the following factors:-

CONFIDENTIAL DISCREET

(a) Lead with its ductile property and low melting point has been seen to become molten when in contact with a detonating explosive [2]. Detonation caused the lead shell surface to become covered with closely packed, fast growing "spikes". These "spikes" which are molten spray will no doubt quickly become vapourised by the explosive gases. The addition of lead vapour in the RDX/TNT explosion products will produce a change in density and in γ the ratio of the specific heats for the gases and products.

(b) The shock strength Y and the shock velocity U are related by the Rankine-Hugoniot formula

$$\frac{U^2}{a^2} = \frac{(\gamma - 1) + Y(\gamma + 1)}{2\gamma}, \quad \dots (1)$$

where a is the velocity of sound in the undisturbed air in front of the shock. An increase in shock strength at a given distance from the charge could be produced if there was a lowering in the value of γ for the air in front of the gaseous products of the explosion or an increase in shock velocity.

(c) The increased density of the explosive gas products due to the presence of lead vapour will bring about an increase in the hydrostatic overpressure in the portion of the shock wave behind the contact surface. An increase in overpressure in the latter portion of the shock wave will increase the positive impulse in the wave as a whole.

From the two case thickness of lead so far fired, it seems possible that a case thicker than 0.218 in. would produce an even greater enhancement than that already obtained. However the weight of the 0.218 in. thick lead case was 11.25 lb which means that any increase in shell thickness will produce an overall charge that is extremely heavy and cumbersome.

6.3 Magnesium Cased Charges

The peak overpressure, positive impulse and positive duration graphs for the magnesium cased charges shown in Figures 6, 8(c) and 9(c) show that the behaviour of the pressures and durations from these charges are different to that of the aluminium cased (section 6.1). The thickest casing gave the greatest reduction in peak pressure and duration close in to the charge. The positive impulses however follow a similar pattern to the aluminium cases, the thinnest casing having the same impulse values as the uncased charge and the thicker casing - 0.788 in. having impulses comparable with the 0.548 in. thick aluminium case. Examination of the case masses in Table 2 shows that the 0.548 in. thick aluminium and the 0.788 in. magnesium cases are almost the same weight being 7.97 and 8.01 lb respectively. Similarly the 0.250 in. aluminium and the 0.437 in. magnesium cases have the same order of weight, they are 3.22 and 4.00 lb respectively. Whether from the aluminium and magnesium cased charges any of the impulse in the shock wave behind the contact surface is due to some vapourisation of the metal cases, as discussed in section 6.2, is open to question. The colour films of the fireball certainly indicate that there is burning

CONFIDENTIAL DISCREET

of the aluminium and magnesium. Since at least 50% of the aluminium and magnesium casings in a given zone were found after the explosion the burning can only be partial. Consequently the amount of aluminium and magnesium vapour present in the explosive gases will be small compared with the lead where no fragments were recovered.

The fireball growth graph in Figure 13 indicates that a magnesium case thinner than 0.437 in. would possibly produce fragments of higher velocity than those from the two thicknesses already examined.

6.4 Steel Cased Charge

Figures 7, 8(d) and 9(d) show that there was a reduction in all three blast parameters for the one steel cased charge that was fired. Close in to the charge the reduction in pressure, impulse and duration compared with an uncased charge is greatest, this difference decreases until at 20 ft the charge the pressures and durations from the cased and uncased charges are the same and the impulses reduced by only 5%. The weight of the steel 0.105 in. casing was 3.88 lb (Table 2), this is comparable to the 0.250 in. aluminium, 0.078 in lead and the 0.437 in. magnesium casings. An examination of Figure 8(a) - (d) shows that the impulse curves for these four casings are, with the exception of the steel, almost identical. The energy required to expand the metal cases of these charges is negligible when compared with the total energy of the explosive. This suggests that there is burning of the aluminium, lead and magnesium cases which contributes to the impulse in the manner discussed in section 6.2.

7. COMPARISON WITH OTHER WORK

7.1 Blast Parameters

Comparison with the work of Dewey, Johnson and Patterson [1] is difficult because their measurements of the effects of light surrounds and casings was carried out almost entirely using reflected impulses, not with side-on impulses as in the present experiments. Their conclusions were that the effect of a casing lighter than the explosive was not to decrease the reflected impulse but to increase it. Whether the casing was chemically reactive, acoustically "matched" to the explosive, simply a plastic loaded with inert material or a powdered aluminium surround, its effect was usually about the same as that of adding an equal mass of explosive to the charge. However, compared with an uncased charge of the same weight as the explosive filling as much as a doubling of reflected impulses was found with aluminium and magnesium casings and in the side-on impulse from a powdered aluminium surround.

In the present work comparing the side-on impulses for the aluminium and magnesium cased charges with those from an uncased charge there is no increase for any charge to case ratio so far examined.

7.2 Fragment Velocities

Gurney [3] worked out a formula for predicting the velocity of the fragments produced by detonating a spherical charge of high explosive

CONFIDENTIAL DISCREET

surrounded by a spherical shell of metal. His formula was

$$v = \sqrt{2E} \sqrt{\frac{c/m}{1 + 3c/5m}} \dots\dots(2)$$

where E is the energy per unit mass of explosive, c is the mass of the explosive, m the mass of the case and v the initial velocity of the fragments.

Using equation (2) the theoretical fragment velocity for the cased charges fired have been calculated and are listed in Table 3, column (4). E was taken as 1200 cal/gm. Comparing the theoretical values in column (4) with those measured from the fireball graph in column (5) it can be seen that at the lower initial velocities the agreement is excellent. With the higher velocities the theoretical values are some 10 - 14% above the experimental values.

8. CONCLUSIONS

(a) For the peak overpressures an enhancement over the values from an uncased RDX/TNT charge was obtained from a 0.218 in. thick lead case and similar values to the uncased charge for the 0.078 in. thick lead casing. All the aluminium, magnesium and steel casings gave a reduction in pressure at all distances from the charge except the furthest distance recorded.

(b) For positive impulses an enhancement was obtained over the uncased charge from the 0.218 in. thick lead casing. The 0.250 in. aluminium, the 0.078 in. lead and the 0.437 in. thick magnesium cases all produced impulses of the same value as the uncased charge. The remaining casings gave a reduction in impulse.

(c) For positive durations all the casings gave a reduction in values compared with the uncased charge. This reduction was greatest nearest the charge and became negligible at the furthest distance recorded.

(d) The initial fragmentation velocities agreed well with theory for the lower velocities and were 10 - 14% in error at higher velocities.

9. RECOMMENDATIONS

The work carried out to date indicates the possibility of obtaining an enhancement in positive impulse with an aluminium casing less than 0.250 in. thick or a magnesium casing less than 0.437 in. thick. In order to ascertain this fact it would be useful to fire at least two more magnesium cased charges of different thicknesses and one round of aluminium.

American work [1] has shown that the greatest impulse enhancement from lightly cased charges was obtained at reduced ambient pressures. Consequently it would probably be informative to repeat the present work reported here at low atmospheric pressure.

10. ACKNOWLEDGMENT

The authors would like to thank those members of the Applied Blast Section who assisted with this work and also the members of the Photographic Section who took the high speed cine films.

CONFIDENTIAL DISCREET

REFERENCES

1. J. M. Dewey, O. T. Johnson and J. D. Patterson, II: "Some Effects of Light Surrounds and Casings on the Blast from Explosives". BRL Report 1218
2. P. M. B. Slate, M. J. W. Billings and P. J. A. Fuller: "The Rupture Behaviour of Metals at High Strain Rates". J. Inst. Metals, 95 (1967)
3. R. W. Gurney: "The Initial Velocities of Fragments from Bombs, Shell and Grenades". BRL Report 405

TABLE 1
Explosive Assemblies Fired

Round No.	Explosive	Weight c	Casing Details			Charge Weight Case Weight $\frac{c}{m}$
			Metal	Weight m	Thickness, in.	
1	RDX/TNT	8 lb 10 $\frac{1}{4}$ oz	None	-	-	-
2	RDX/TNT	7 lb 15 oz	Magnesium	4 lb 0 oz	0.437	1.99
3	RDX/TNT	8 lb 4 $\frac{1}{4}$ oz	Magnesium	8 lb 0 $\frac{1}{4}$ oz	0.788	1.03
4	RDX/TNT	8 lb 2 oz	Aluminium	7 lb 15 $\frac{1}{2}$ oz	0.548	1.02
5	RDX/TNT	8 lb 2 oz	Aluminium	12 lb 0 $\frac{1}{4}$ oz	0.786	0.68
6	RDX/TNT	8 lb 2 oz	Steel	3 lb 14 oz	0.105	2.09
7	RDX/TNT	8 lb 3 oz	Lead	3 lb 12 oz	0.078	2.18
8	RDX/TNT	8 lb 3 oz	Lead	11 lb 4 oz	0.218	0.73
9	RDX/TNT	8 lb 3 oz	Lead	11 lb 4 oz	0.217	0.73
10	RDX/TNT	8 lb 3 oz	Aluminium	3 lb 3 $\frac{1}{2}$ oz	0.250	2.54

TABLE 2
Summary of Blast Parameter Results

Blast Parameter (1)	Case Metal (2)	Case Thickness, in. (3)	Case Mass, lb (4)	Figure Number (5)	Remarks (6)
Peak Overpressure	Aluminium	0.250	3.22	4	At 5 ft from the charge all three case thicknesses produced a reduction in overpressure compared with that from an uncased RDX/TNT sphere. The least reduction was from the 1/2 in. shell being 20%, for the 1/4 and 3/8 in. cases the reductions were 40% and 60% respectively. With increasing distance from the charge the pressures from the cased and uncased spheres approach a similar value
	Lead	0.078 0.218	3.75 11.25	5	
	Magnesium	0.437 0.780	4.00 8.01	6	
Positive Impulse	Steel	0.105	3.88	7	There is a 25% reduction in pressure 5 ft from the charge, this percentage decreases with increasing distance and at 20 ft the pressures are the same as those from an uncased charge
	Aluminium	0.250 0.548 0.786	3.22 7.97 12.01	8(a) 8(a) 8(a)	The impulses from the 0.250 in. case charge were identical to those from an uncased RDX/TNT charge. However, the impulses from the 0.548 and 0.786 in. shells were reduced by 15% and 30% respectively over the whole of the recorded range
	Lead	0.078 0.218	3.75 11.25	8(b) 8(b)	For the 0.078 in. case the impulses were a few percent higher than the uncased charge values. For the 0.218 in. shell there was a 10% impulse enhancement at 5 ft from the charge this enhancement increased to 20% at 20 ft
	Magnesium	0.437 0.788	4.00 8.01	8(c) 8(c)	The 0.437 in. case gave identical impulses to those from the uncased charge over the range 4 - 10 ft, beyond 10 ft there was a 5% impulse enhancement. For the 0.788 in. shell there was a reduction in impulse of 25% at 4 ft decreasing to 10% at 20 ft
Positive Duration	Steel	0.105	3.88	8(d)	There was an impulse reduction over the whole recorded range of between 5 and 15%
	Aluminium	0.250 0.548 0.786	3.22 7.97 12.01	9(a) 9(a) 9(a)	The durations for all three case thicknesses were less than those from an uncased RDX/TNT charge. For the 0.250 and 0.786 in. cases the durations were about 30% lower at 5 ft, this difference decreased to 8% at 20 ft. The 0.548 in. shell had durations 40% less at 5 ft and this dropped to 15% at 20 ft
	Lead	0.078 0.218	3.75 11.25	9(b) 9(b)	The durations at 5 ft from the 0.078 and 0.218 in. shells were 10% and 25% lower respectively than those from the uncased charge, these percentages decreased until at 20 ft the durations for the cased and uncased charges were identical
	Magnesium	0.437 0.788	4.00 8.01	9(c) 9(c)	The durations exhibited a similar behaviour to those from the lead shells. At 5 ft the 0.437 and 0.788 in. cases had 25% and 30% lower durations respectively and at 20 ft they were the same as those from an uncased charge
	Steel	0.105	3.88	9(d)	The durations behaved in the same way as those from lead and magnesium cases, at 5 ft they were 15% lower

TABLE 3

Fragment Velocities

Round (1)	Casing (2)	Thickness, in. (3)	Theoretical [3] Velocity, ft/s (4)	Measured Velocity from Fireball Growth Graphs, ft/s	
				Over First 400 μ s (5)	At 6 ft from Charge Centre (6)
2	Magnesium	0.437	10000	8600	8000
3	Magnesium	0.788	8300	7700	5800
4	Aluminium	0.548	8300	7700	7000
5	Aluminium	0.786	7200	7200	5600
6	Steel	0.105	10000	8600	8100
7	Lead	0.078	10100	9100*	2800
8	Lead	0.218	7400	7400*	2500
10	Aluminium	0.250	10400	9400	7400

[3] From Gurney's formula for a cased sphere.

* Measured over first 250 μ s.

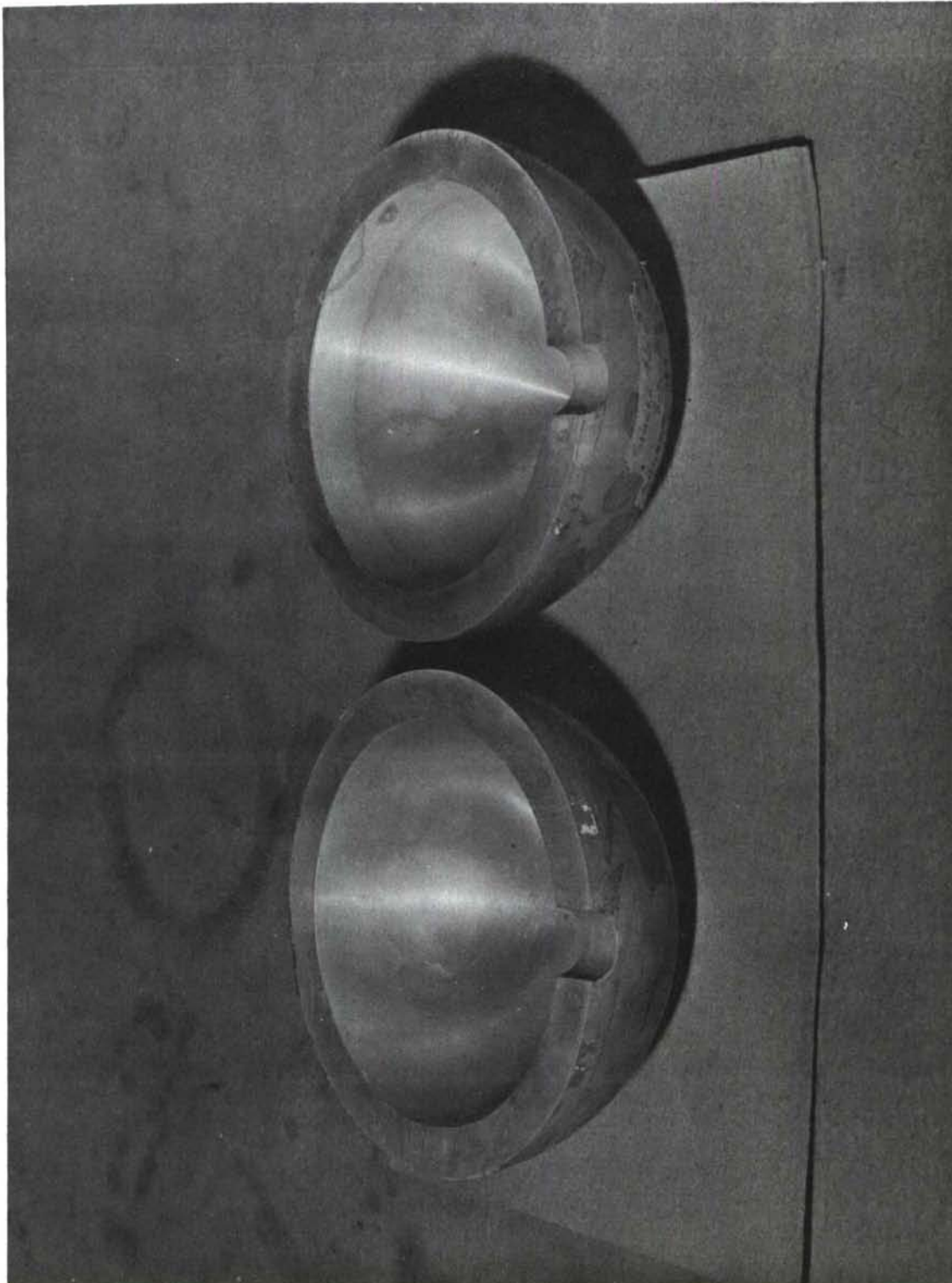

FIGURE 1. 0.788 INCH THICK MAGNESIUM SHELL

CONFIDENTIAL DISCREET

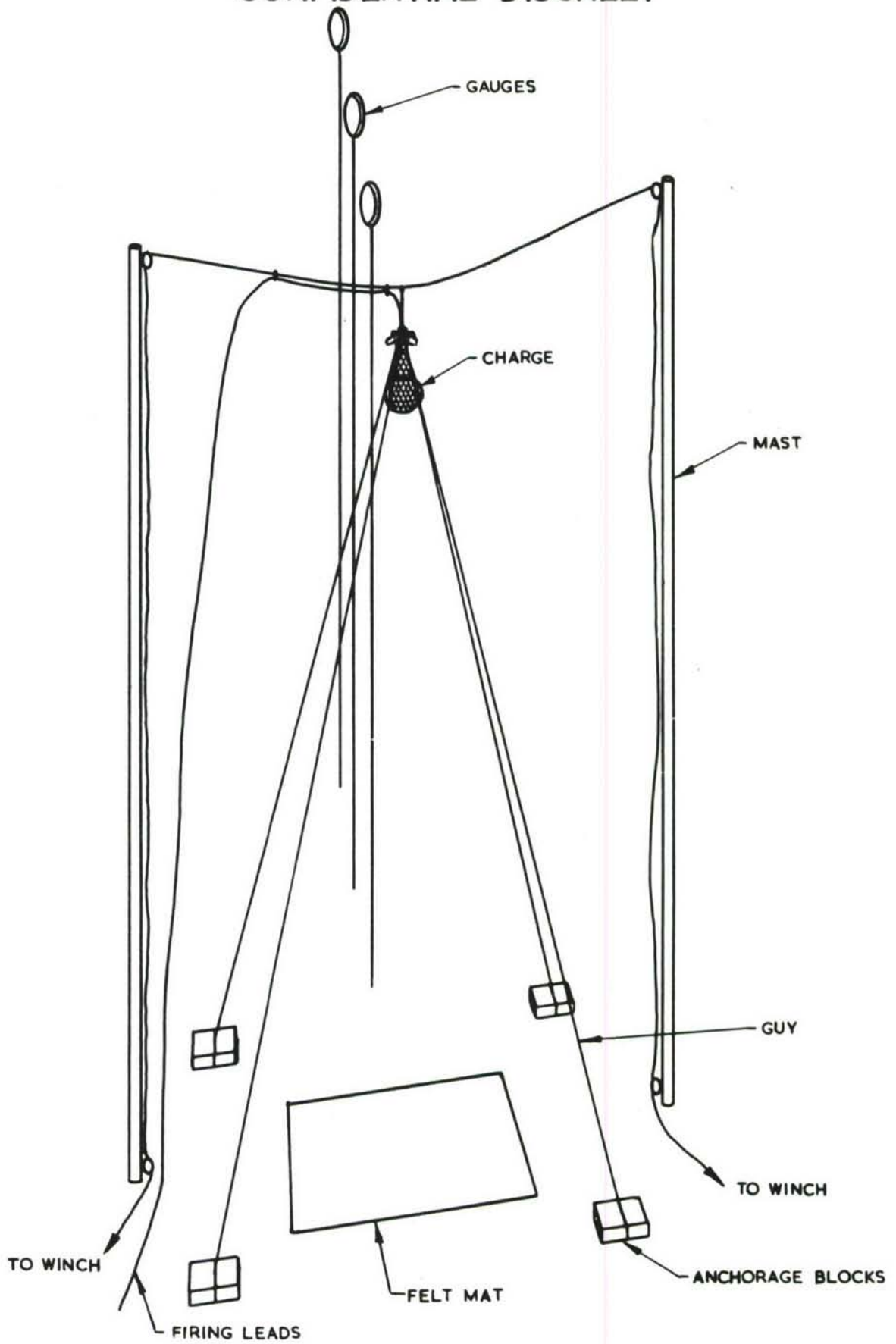

FIGURE 2. DIAGRAM OF EXPERIMENTAL ARRANGEMENT

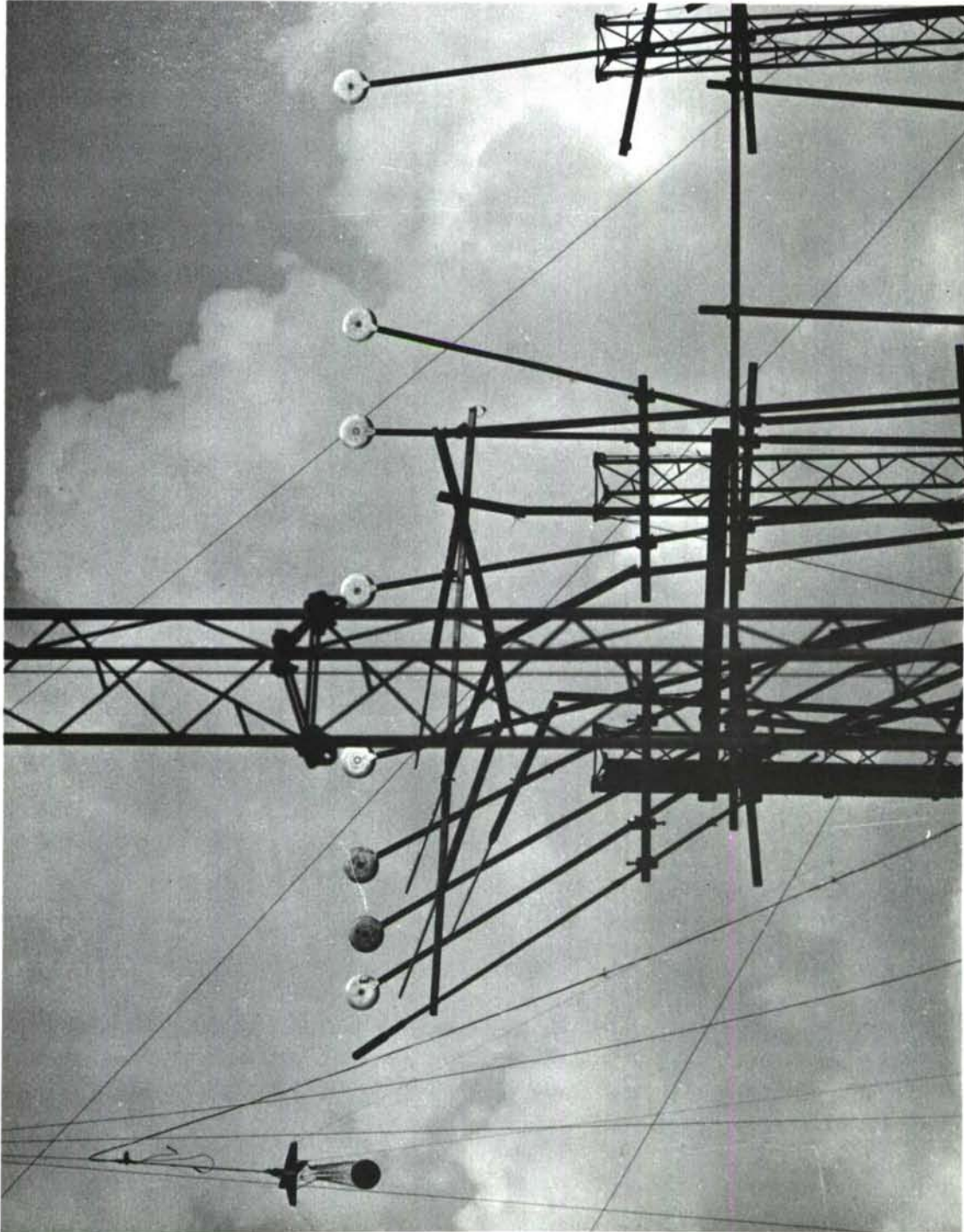

FIGURE 3. PIEZO-ELECTRIC GAUGE ARRANGEMENT

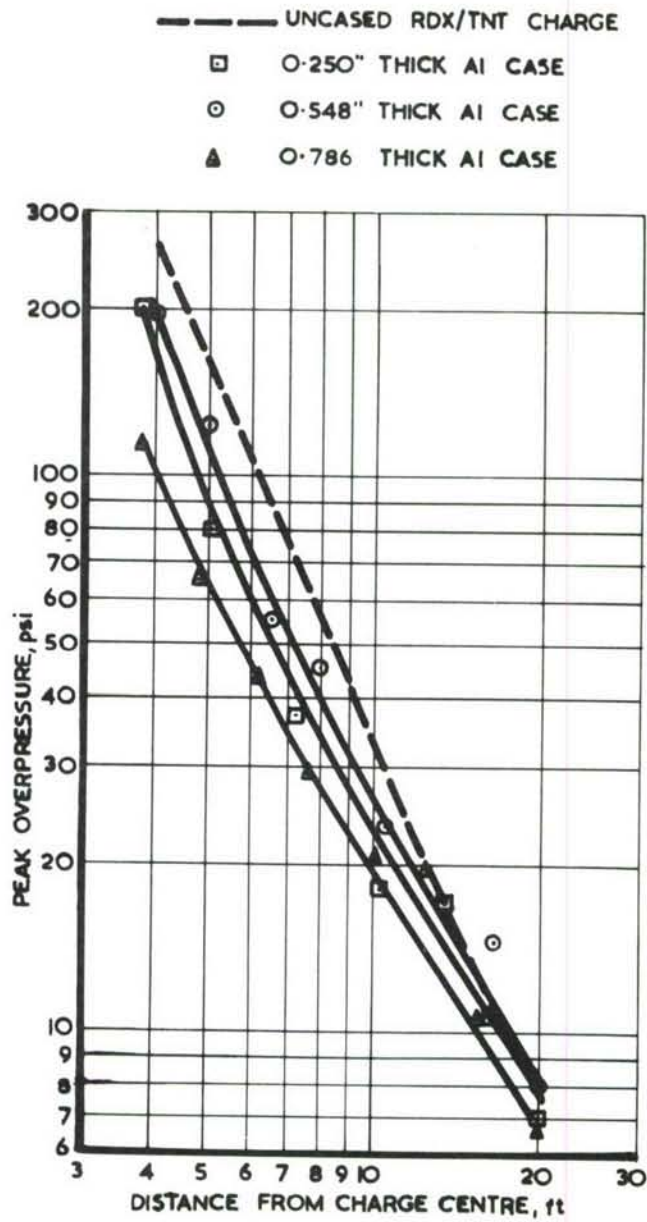

FIGURE 4. PEAK OVERPRESSURE vs DISTANCE FOR ALUMINIUM CASED SPHERES

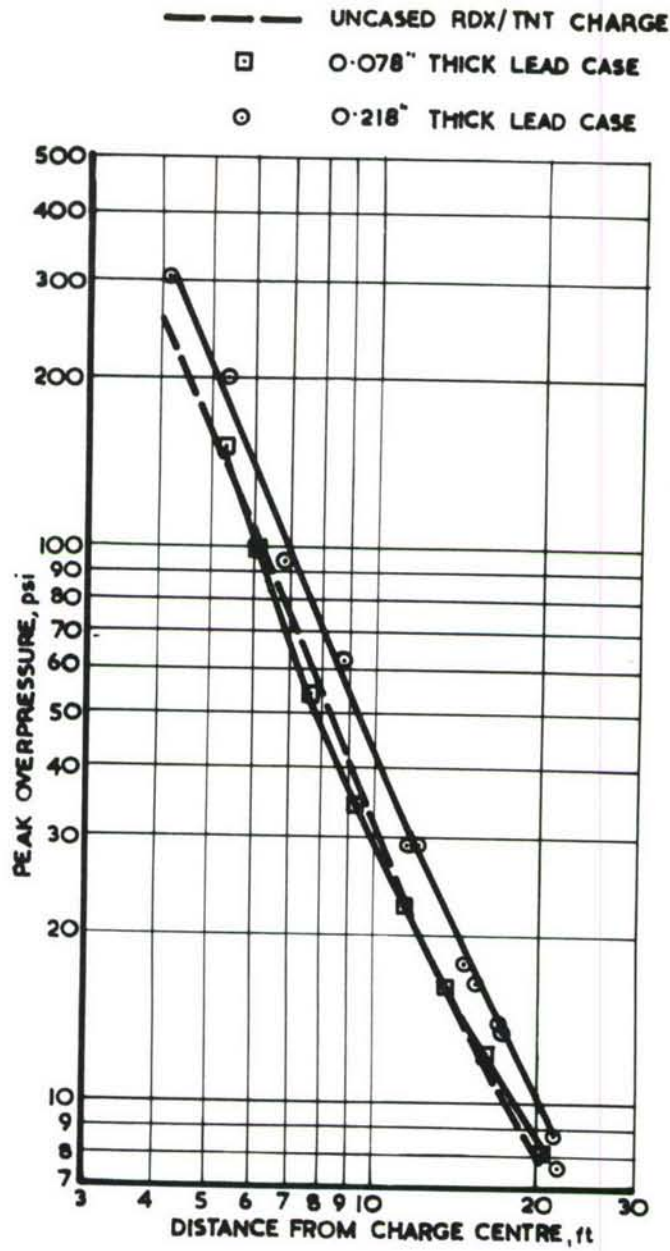

FIGURE 5. PEAK OVERPRESSURE vs DISTANCE FOR LEAD CASED SPHERES

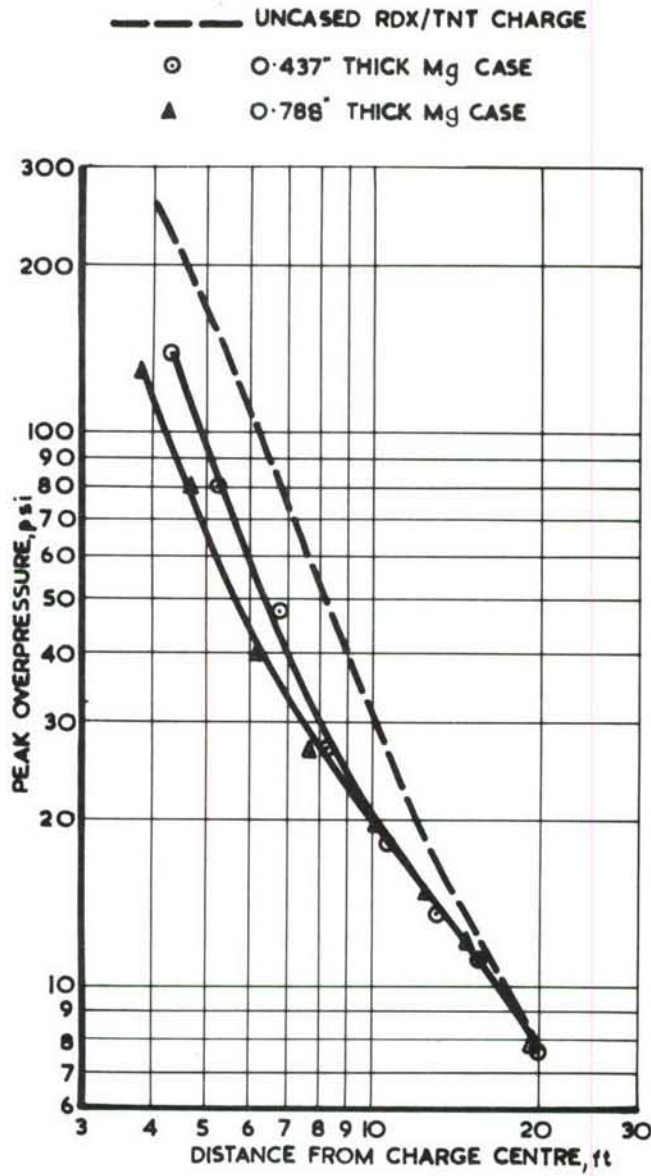

FIGURE 6. PEAK OVERPRESSURE vs DISTANCE FOR MAGNESIUM
CASED SPHERES

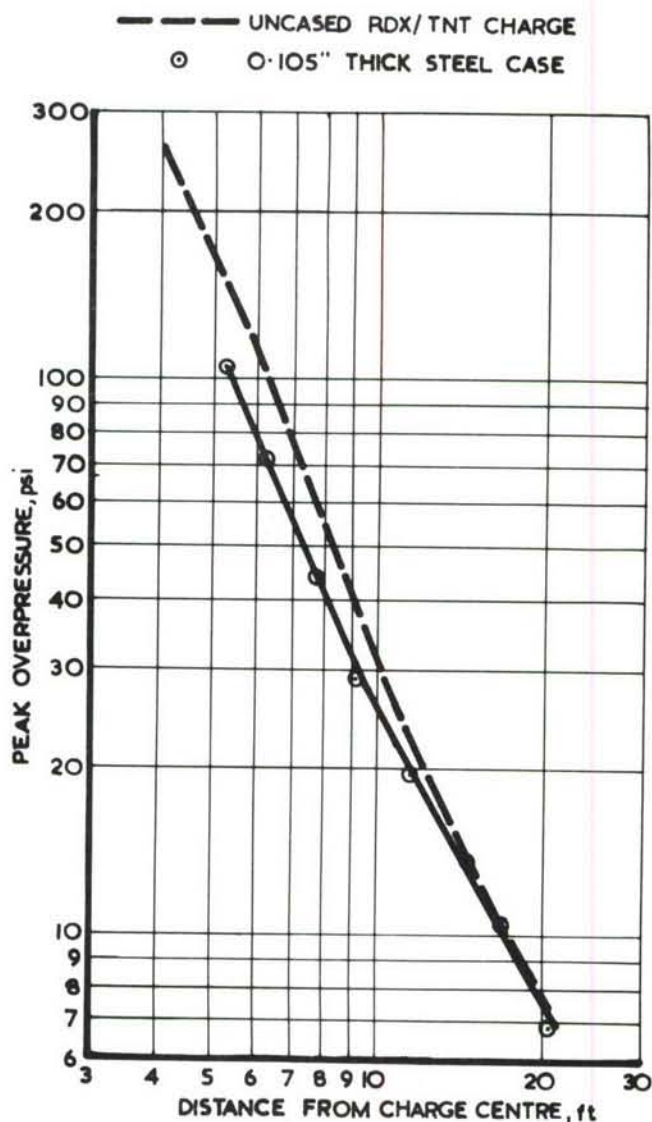
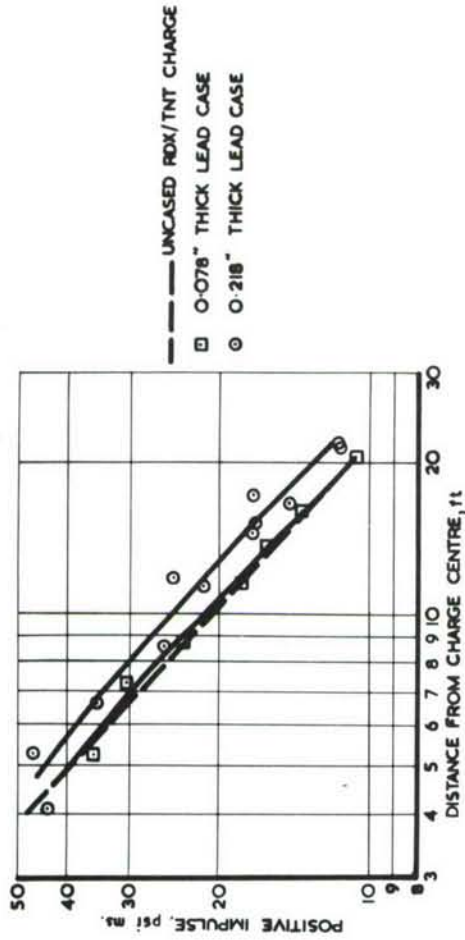
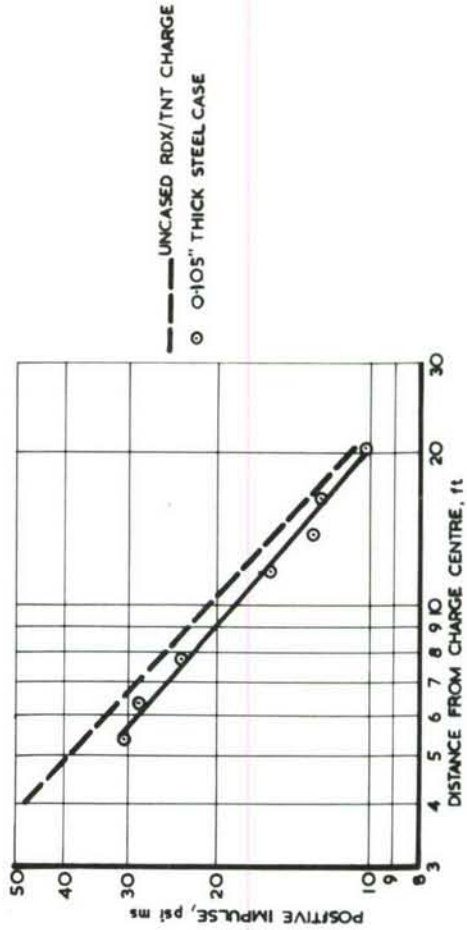

FIGURE 7. PEAK OVERPRESSURE vs DISTANCE FOR STEEL
CASED SPHERE



b) LEAD CASED SPHERES



d) STEEL CASED SPHERE

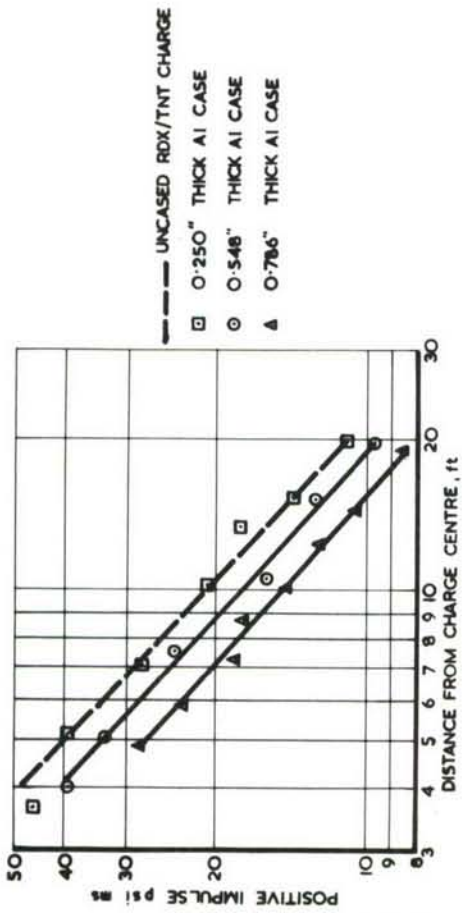

a) ALUMINIUM CASED SPHERES

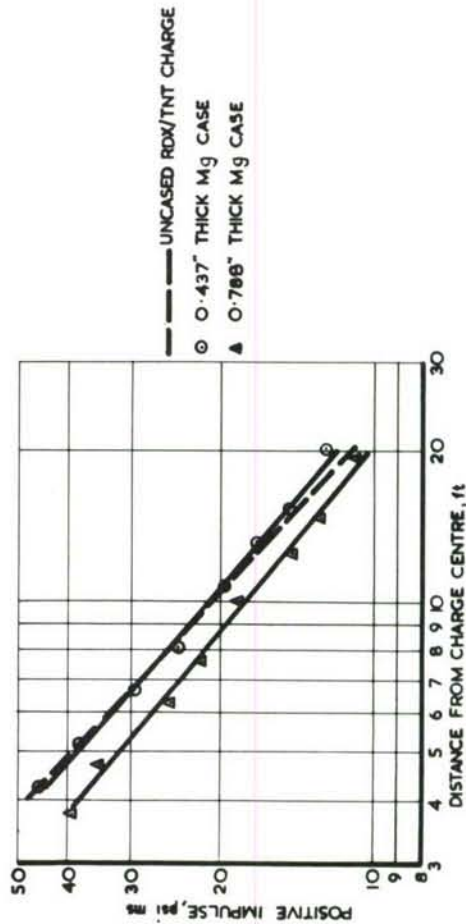

c) MAGNESIUM CASED SPHERES

FIGURE 8. POSITIVE IMPULSE vs DISTANCE FOR SPHERICAL 8lb RDX/TNT CHARGES CASED IN VARIOUS METALS

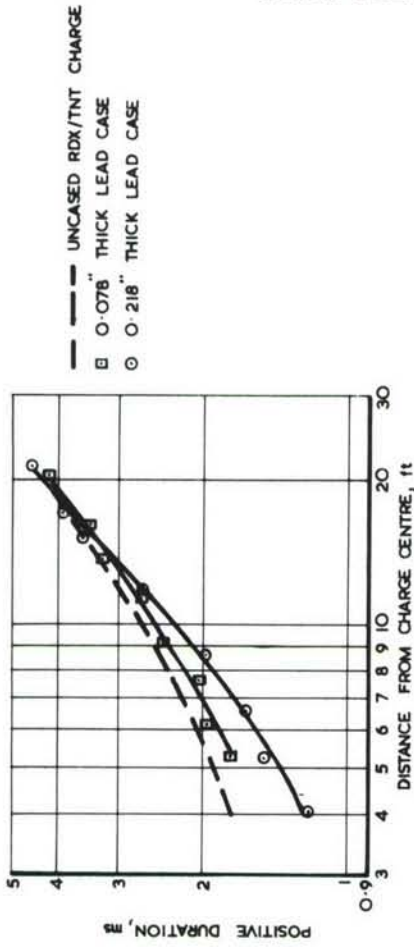

b) LEAD CASED SPHERES

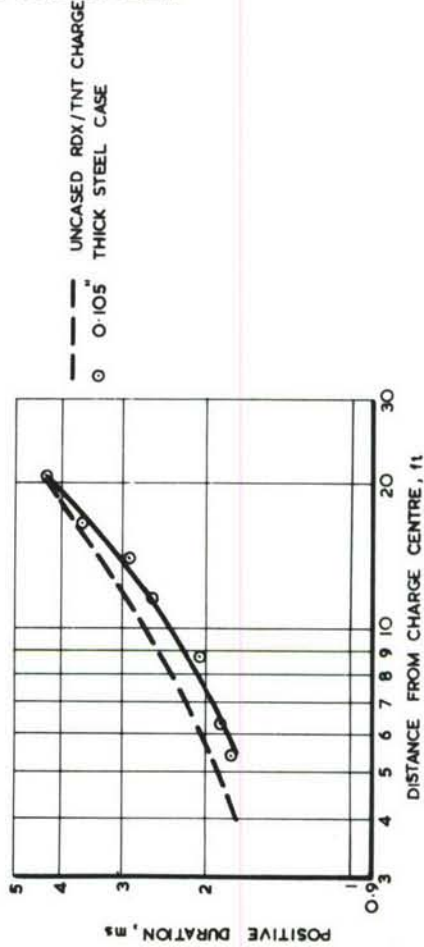

d) STEEL CASED SPHERE

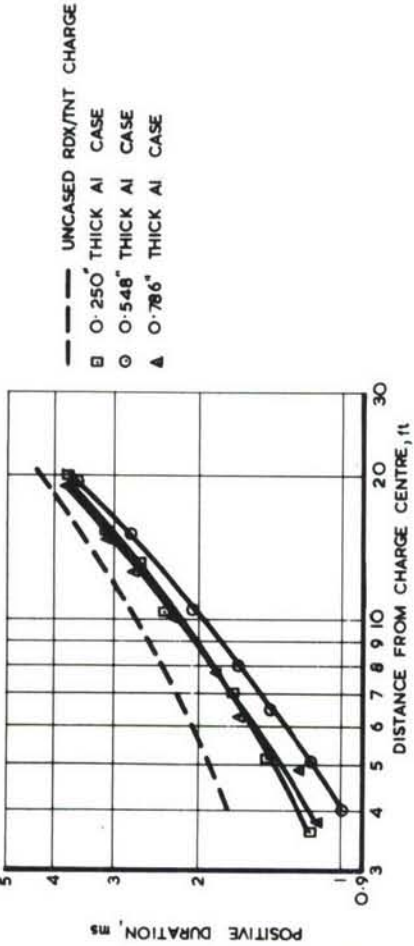

c) ALUMINIUM CASED SPHERES

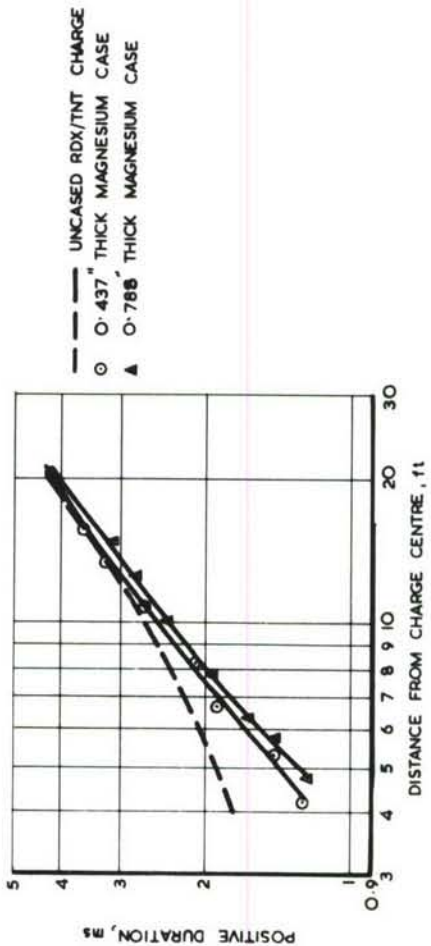

c) MAGNESIUM CASED SPHERES

FIGURE 9 POSITIVE DURATION vs DISTANCE FOR SPHERICAL 8lb RDX/TNT CHARGES CASED IN VARIOUS METALS

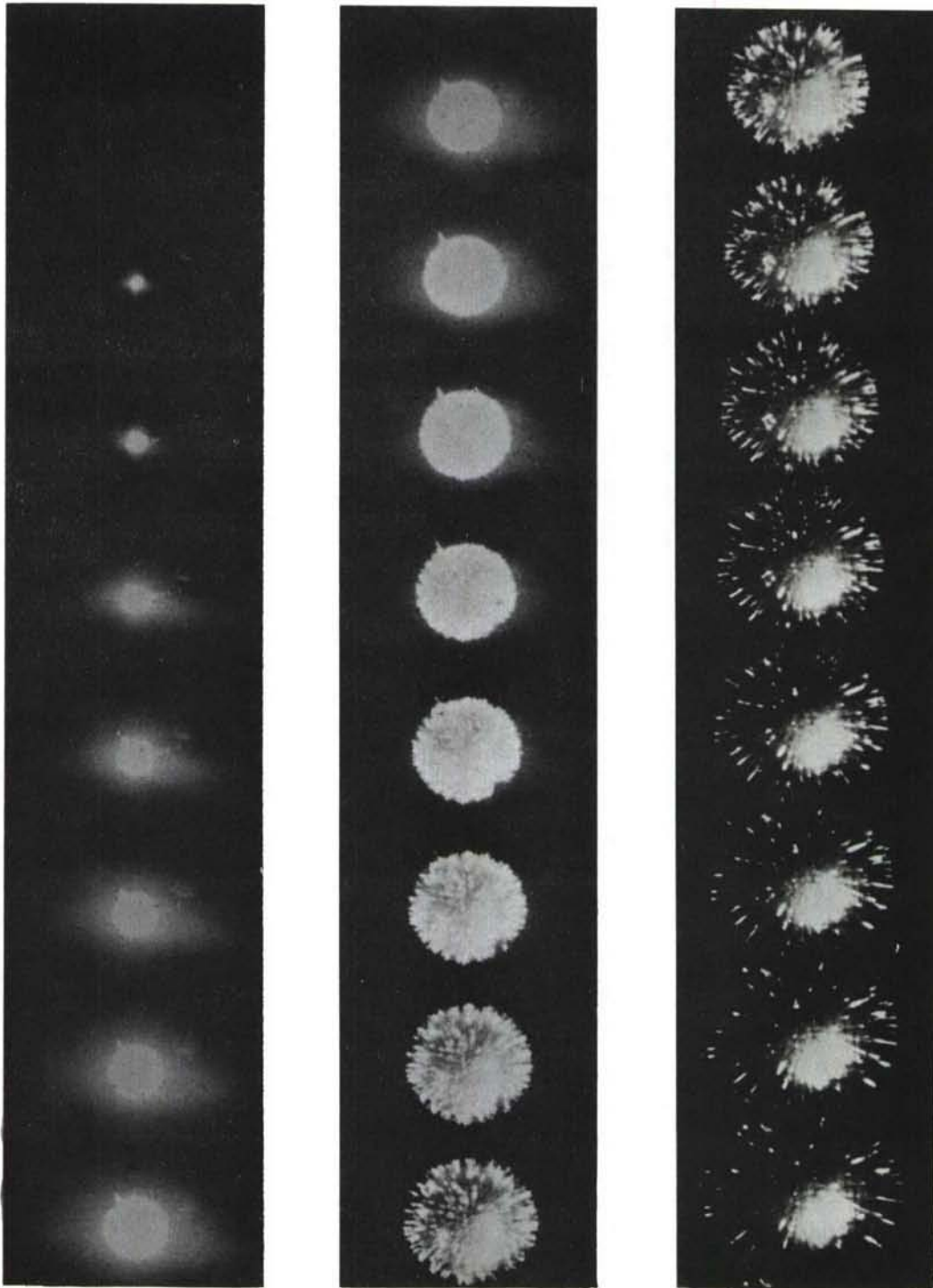

FIGURE 10. FIREBALL GROWTH OF 0.788 INCH THICK MAGNESIUM
CASING TAKEN AT 12,200 HALF FRAMES PER SECOND

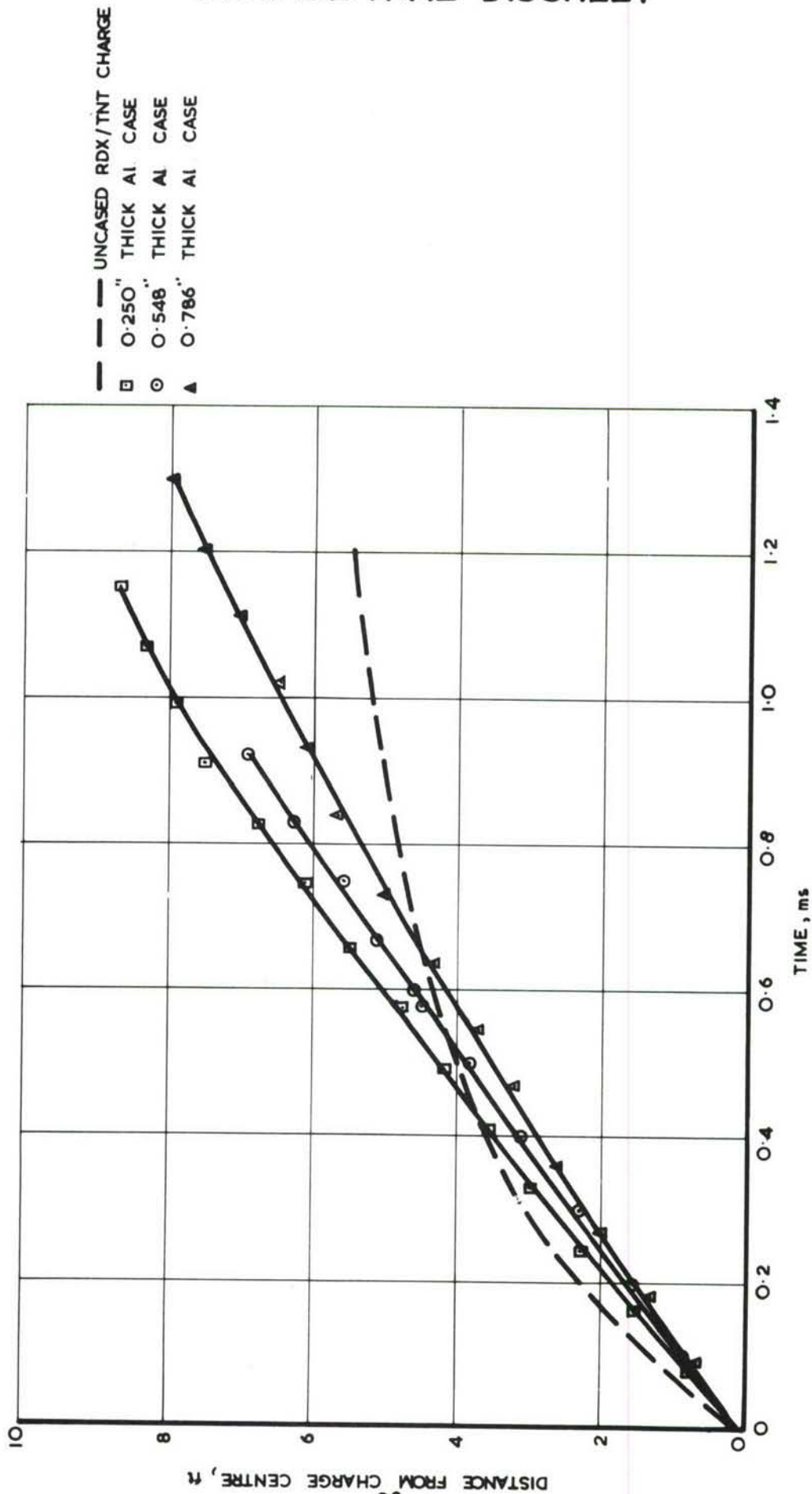

FIGURE II. FIREBALL GROWTH FOR ALUMINIUM CASSED CHARGES

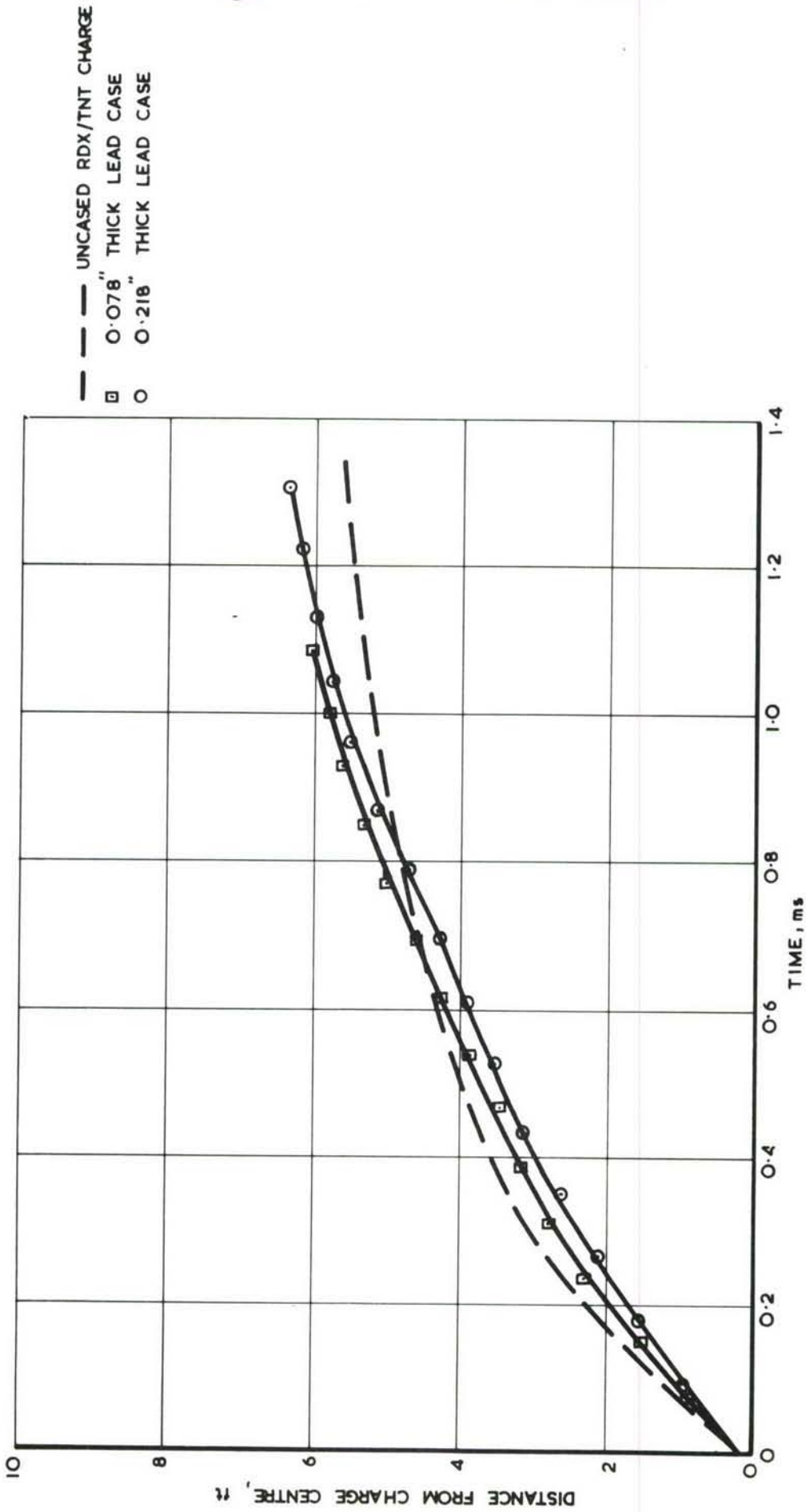

FIGURE 12. FIREBALL GROWTH FOR LEAD CASED CHARGES

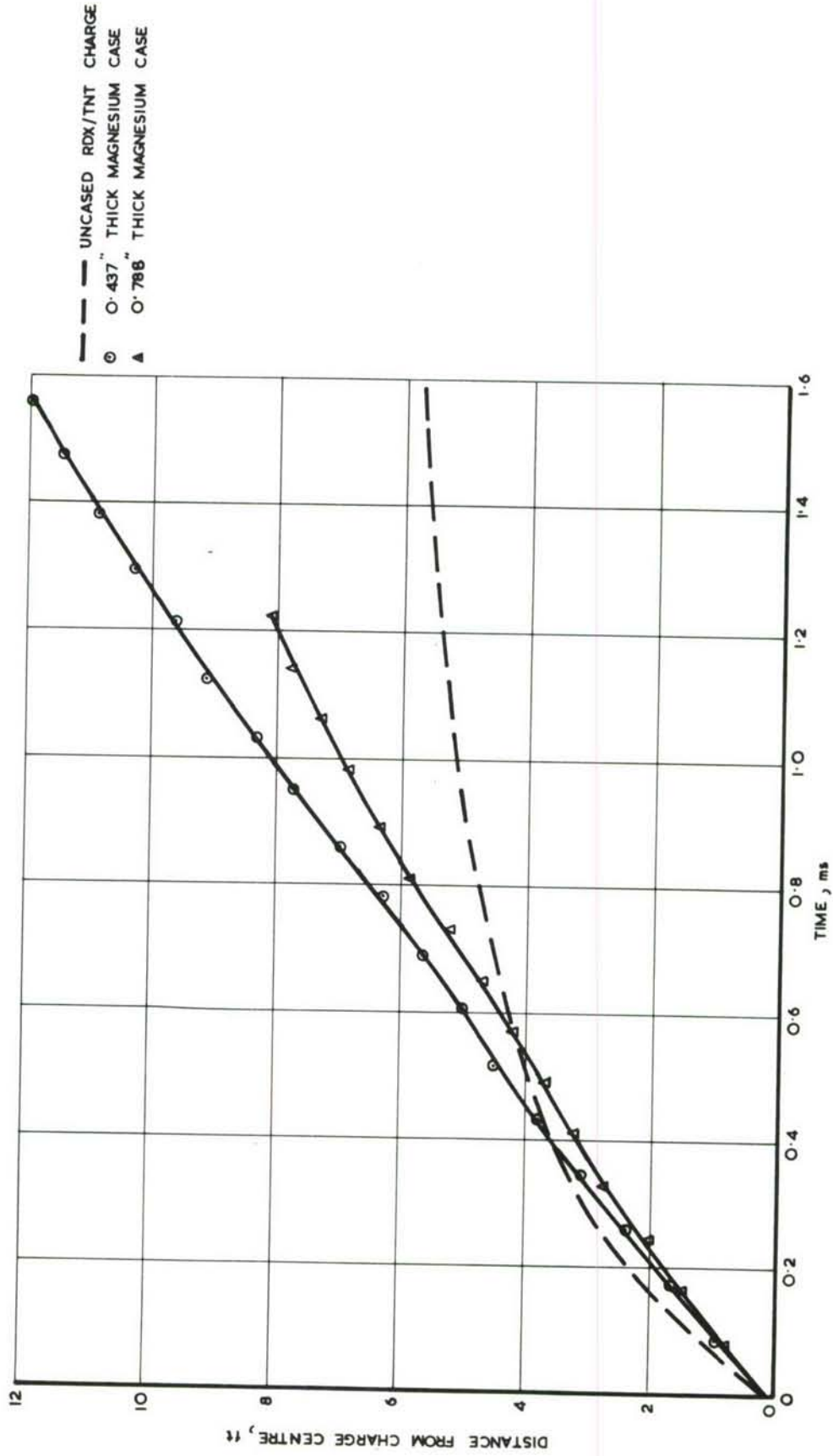

FIGURE 13. FIREBALL GROWTH FOR MAGNESIUM CASED CHARGES

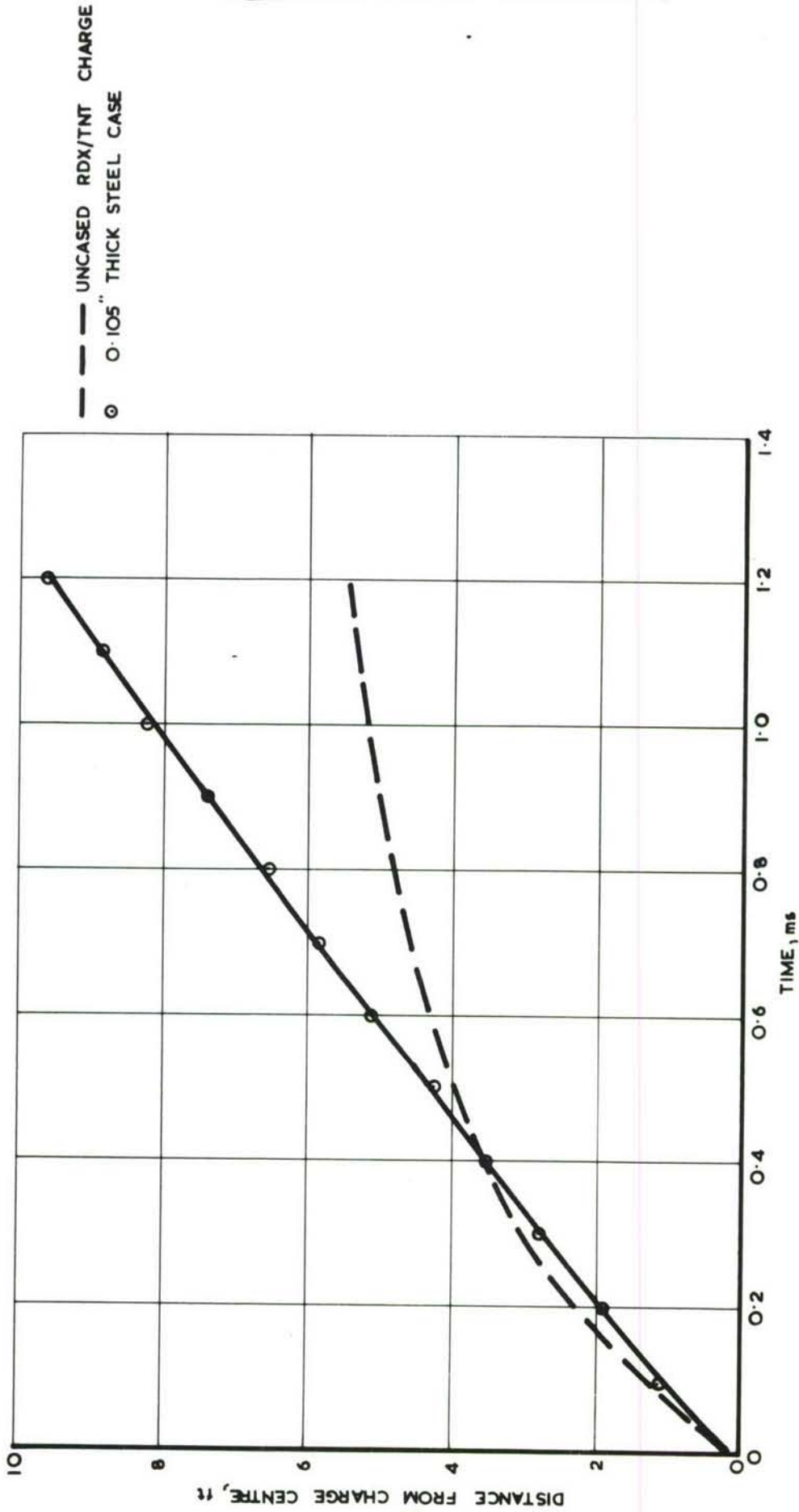

FIGURE 14. FIREBALL GROWTH FOR STEEL CASED CHARGES

~~CONFIDENTIAL~~

~~DISCREET~~

UNCLASSIFIED



UNCLASSIFIED

~~CONFIDENTIAL~~

~~DISCREET~~