

**Measurements of Gulf Stream Transport  
With a Towed Transport Meter (TTM2)  
on R/V *Oceanus* Cruise 216**

by

John H. Dunlap  
Robert G. Drever  
Maureen A. Kennelly  
Thomas B. Sanford

Technical Report  
**APL-UW TR9209**  
April 1992



**Applied Physics Laboratory University of Washington**  
1013 NE 40th Street Seattle, Washington 98105-6698

# Report Documentation Page

*Form Approved*  
*OMB No. 0704-0188*

Public reporting burden for the collection of information is estimated to average 1 hour per response, including the time for reviewing instructions, searching existing data sources, gathering and maintaining the data needed, and completing and reviewing the collection of information. Send comments regarding this burden estimate or any other aspect of this collection of information, including suggestions for reducing this burden, to Washington Headquarters Services, Directorate for Information Operations and Reports, 1215 Jefferson Davis Highway, Suite 1204, Arlington VA 22202-4302. Respondents should be aware that notwithstanding any other provision of law, no person shall be subject to a penalty for failing to comply with a collection of information if it does not display a currently valid OMB control number.

1. REPORT DATE <b>01 APR 1992</b>	2. REPORT TYPE <b>N/A</b>	3. DATES COVERED <b>-</b>	
4. TITLE AND SUBTITLE <b>Measurements of Gulf Stream Transport with a Towed Transport Meter (TTM2) on R/V Oceanu Cruise 216.</b>		5a. CONTRACT NUMBER	
		5b. GRANT NUMBER <b>NSF Grant OCE-90-00050</b>	
		5c. PROGRAM ELEMENT NUMBER	
6. AUTHOR(S) <b>Dunlap, John H., Drever, Robert G., Kennelly, Maureen A., Sanford, Thomas B.</b>		5d. PROJECT NUMBER	
		5e. TASK NUMBER	
		5f. WORK UNIT NUMBER	
7. PERFORMING ORGANIZATION NAME(S) AND ADDRESS(ES) <b>Applied Physics Laboratory University of Washington 1013 NE 40th St. Seattle, WA. 98105-6698</b>		8. PERFORMING ORGANIZATION REPORT NUMBER <b>APL-UW-TR-9209</b>	
9. SPONSORING/MONITORING AGENCY NAME(S) AND ADDRESS(ES)		10. SPONSOR/MONITOR'S ACRONYM(S)	
		11. SPONSOR/MONITOR'S REPORT NUMBER(S)	
12. DISTRIBUTION/AVAILABILITY STATEMENT <b>Approved for public release, distribution unlimited</b>			
13. SUPPLEMENTARY NOTES <b>The original document contains color images.</b>			
14. ABSTRACT			
15. SUBJECT TERMS			
16. SECURITY CLASSIFICATION OF:			17. LIMITATION OF ABSTRACT <b>SAR</b>
a. REPORT <b>unclassified</b>	b. ABSTRACT <b>unclassified</b>	c. THIS PAGE <b>unclassified</b>	
19a. NAME OF RESPONSIBLE PERSON			

## Acknowledgments

*We thank Terry Joyce and Kathryn Kelly of the Woods Hole Oceanographic Institution for allowing us the opportunity to participate in OC216. We gratefully thank Captain Howland and all the ship's personnel aboard R/V Oceanus for their cooperation and competence. Jim Osse of APL-UW was responsible for much of the engineering effort to modify TTM into TTM2. We thank Dicky Allison for her efforts in getting this report together, and Jane Verrall for her modeling efforts and for supplying Figures 8, 9, and 13. The development of the TTM was supported by the National Science Foundation under Grant OCE-84-13234, a project jointly funded by NSF's Oceanographic Facilities Support Section and NOAA's National Ocean Service Engineering Staff. Funding to participate on the Oceanus cruise was provided by National Science Foundation Grant OCE-90-00050.*

## ABSTRACT

Measurements of oceanic velocities were made with a towed transport meter (TTM2) during R/V *Oceanus* cruise 216 from 30 November to 13 December 1989 to observe surface and subsurface flows under GEOSAT tracks between the continental United States and Bermuda. TTM2, a single-axis version of the TTM electromagnetic sensor package, determines the motionally induced electric field parallel to the ship's heading. The electric field is denoted as  $F_z (\mathbf{v} - \bar{\mathbf{v}}^*)$  where  $F_z$  is the vertical component of the earth's magnetic field,  $\mathbf{v}$  is the surface velocity component of the ocean normal to the ship's heading, and  $\bar{\mathbf{v}}^*$  is the conductivity-weighted, vertically averaged velocity component normal to the ship's heading. The electric field measurement is combined with vessel motion determined from LORAN-C to obtain  $\bar{\mathbf{v}}^*$ . Corrections were made for electrical conductivity factors and vessel windage effects to yield continuous determination of the component  $\bar{\mathbf{v}}$  normal to the vessel's track. The estimates of  $\bar{\mathbf{v}}$  were multiplied by water depth and integrated along the track to determine the volume transport distribution between the U.S. and Bermuda. The TTM2 instrument system, its usage on *Oceanus* cruise 216, and preliminary results are discussed. A transport of 60 Sv was observed across the Gulf Stream offshore of Cape Hatteras. Larger transports ( $> 100$  Sv) were detected along the track from Cape Hatteras to Bermuda in a large cold-core eddy.

## TABLE OF CONTENTS

	<i>Page</i>
1. Introduction.....	1
1.1 Background.....	1
1.2 <i>Oceanus</i> Cruise 216.....	2
2. Instrumentation.....	5
2.1 TTM2.....	5
2.1.1 EM interpretation.....	5
2.1.2 System configuration.....	6
2.1.3 System deployment.....	13
2.2 Navigation.....	15
2.3 ADCP.....	15
2.4 SAIL.....	15
2.5 CTD Casts.....	16
2.6 XBT Drops.....	16
3. The Experiment.....	18
3.1 Section 1 (Woods Hole to Bermuda).....	18
3.2 Section 2 (Bermuda to Cape Hatteras).....	21
3.3 Section 3 (Cape Hatteras to Bermuda).....	22
3.4 Section 4 (Bermuda to Woods Hole).....	22
4. Data Processing.....	24
4.1 TTM2 Data.....	24
4.1.1 Vessel leeway effects.....	24
4.1.2 Conductivity-velocity correlation effect, $\gamma$ .....	25
4.1.3 Bottom conductance effect, $\lambda$ .....	25
4.1.4 Conversion of TTM observations to volume transport.....	29
4.2 Navigation Data.....	29
4.2.1 LORAN-C.....	29
4.2.2 Ship's heading.....	30
4.3 ADCP Data.....	30
5. Preliminary Results.....	31
6. Discussion.....	38
7. References.....	39

## LIST OF FIGURES

	<i>Page</i>
Figure 1. Ship track for R/V <i>Oceanus</i> cruise 216.....	3
Figure 2. TTM2 tow body and towing configuration.....	7
Figure 3. Block diagram of TTM2.....	9
Figure 4. Configuration of TTM2 data-acquisition system.....	11
Figure 5. Block diagram of TTM2 deck box.....	12
Figure 6. Vessel tracks for sections 1-4.....	20
Figure 7. Velocity profile taken in the Gulf Stream by the AVP during POLYMODE.....	26
Figure 8. A model of the dependence of the conductivity-velocity effect.....	27
Figure 9. A model of sediment thickness and electrical conductivity.....	28
Figure 10. Infrared satellite image of the Gulf Stream region for day 316 (10 November 1989).....	33
Figure 11. Velocity determined along section 4.....	35
Figure 12. Isotherm depths and volume transport for section 4.....	36
Figure 13. Comparison of three estimates of volume transport across the Gulf Stream.....	37

## LIST OF TABLES

	<i>Page</i>
Table 1. TTM2 deployments, OC216.....	13
Table 2. TTM2 calibration runs, OC216.....	14
Table 3. Section log, OC216.....	21

## 1. INTRODUCTION

### 1.1 Background

Knowledge of storage and movement of heat in the ocean is important to our understanding of climate. In 1984, the Applied Physics Laboratory (APL) of the University of Washington undertook an instrument-development program to address the need for improved technologies for studying meridional (north-south) heat transport in the ocean. The result of that program is a unique instrument which can be used to investigate heat transport mechanisms and ocean dynamics on subgyre scales and within mesoscale eddies. In developing this system, special emphasis has been given to measuring barotropic (depth-averaged) velocities with high spatial resolution. Methods appropriate for use from underway vessels, especially nonresearch ships or volunteer observing ships, have also been emphasized.

The first instrument to be developed under the APL program was the Towed Transport Meter (TTM). Motional EMFs measured by the TTM are combined with vehicle velocities measured by navigation methods such as LORAN-C to determine vertically averaged, or barotropic, velocities. It is assumed that the TTM's velocity and that of the towing ship are the same. The TTM was the first device to observe all three components of the oceanic electric field—longitudinal, vertical, and transverse. It achieved the difficult transverse and vertical measurements by using a spinning nose with a short electrode spacing. The goal of the TTM development was to determine ocean surface and depth-averaged velocities within an uncertainty of about  $2 \text{ cm s}^{-1}$  averaged over distances of 4 km from a vessel under way. A complete description of the TTM instrument system is given by Dunlap et al. (1990).

Sea trials of the TTM were conducted in 1986 (Sanford et al., 1988). The TTM was subsequently used in 1987 to survey the barotropic and baroclinic structure of the Gulf Stream and recirculation region in conjunction with the pilot SYNOP program (Drever et al., 1988).

The data acquired by the TTM demonstrated the feasibility of the design concept. Transport estimates of the Florida Current derived from TTM data agreed well with transport values determined from voltages measured across the submarine cable between Jupiter, Florida, and Settlement Point on Grand Bahama Island. However, use of the TTM during underway operations required the support of a large scientific party. This requirement prevented its use on nonresearch ships or volunteer observing ships with only a minimal support crew.

Modifications were therefore undertaken to develop a simplified version of the TTM. The resulting instrument, denoted TTM2, collects only the component of the oceanic electric field parallel to the ship's heading. In this regard it is identical to the classic geomagnetic-electro-kinetograph, or GEK (von Arx, 1950).

## 1.2 OCEANUS Cruise 216

In 1989, Dr. Terry Joyce and Dr. Kathryn Kelly of the Woods Hole Oceanographic Institution (WHOI) provided us the opportunity to tow TTM2 during R/V *Oceanus* Cruise 216 as part their Gulf Stream Upper Ocean Studies Program. The goal of the WHOI work was to study the upper-ocean structure and transport of the Gulf Stream through the use of shipboard *in situ* sampling with expendable bathythermographs (XBTs) and an Acoustic Doppler Current Profiler (ADCP) combined with satellite infrared imagery and GEOSAT altimetry data. The transports derived using the *in situ* data were of direct interest for comparison with the estimates of total transport derived with the electromagnetic (EM) sensor, TTM2.

*Oceanus* Cruise 216 took place from 30 November to 13 December during the fall of 1989. The ship track is shown in Figure 1. The cruise consisted of four sections: Woods Hole, Massachusetts, to Bermuda; Bermuda to the 200 m isobath off Cape Hatteras, North Carolina; Cape Hatteras to Bermuda; and Bermuda to Woods Hole. These sections are denoted as sections 1, 2, 3, and 4, respectively. TTM2 was towed along each of these sections. At the time of the cruise, GEOSAT was in a 17-day exact-repeat

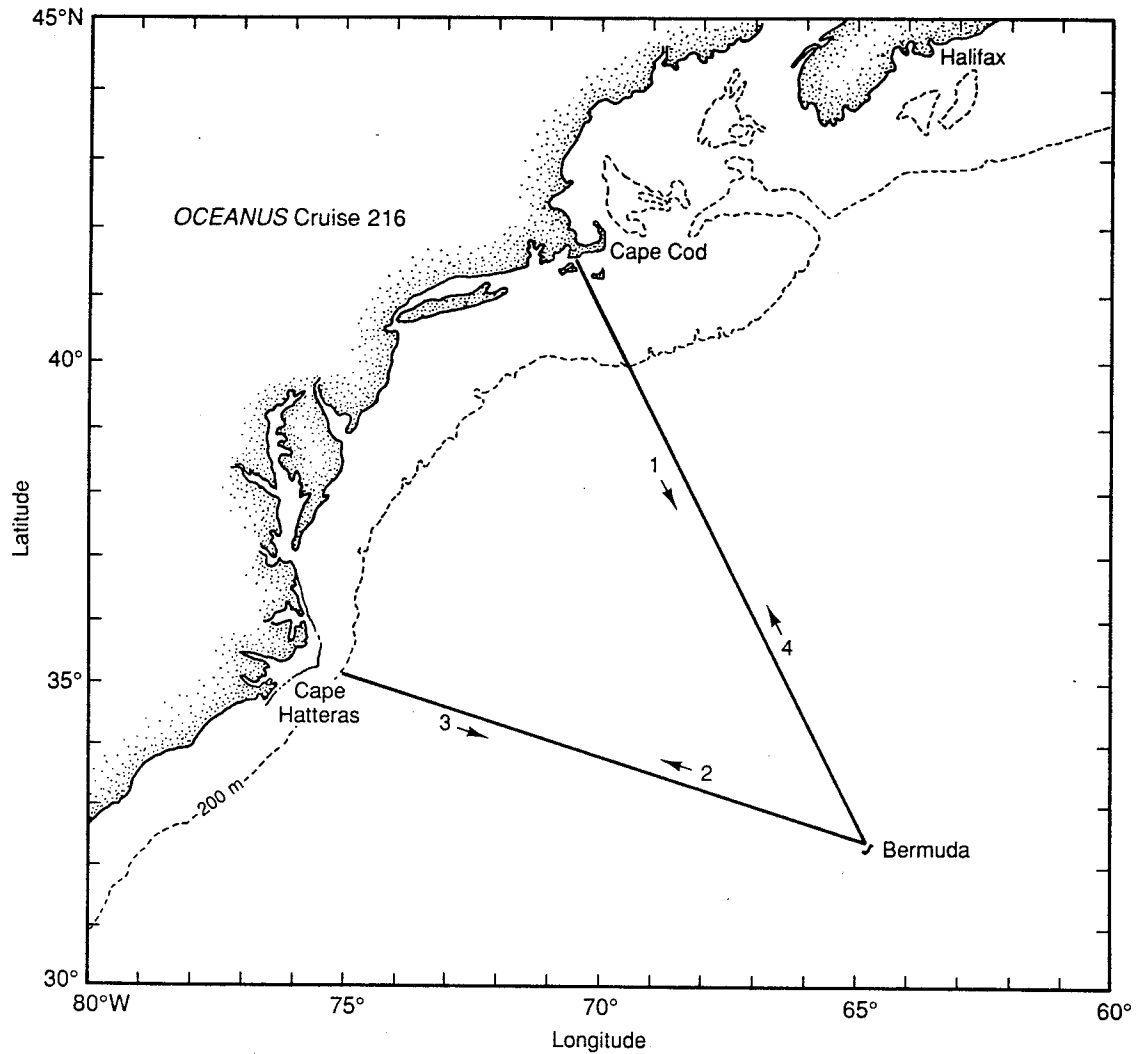

*Figure 1. Ship track for R/V Oceanus cruise 216. The cruise consisted of four sections: Woods Hole to Bermuda; Bermuda to the 200 m isobath off Cape Hatteras, North Carolina; Cape Hatteras to Bermuda, and Bermuda to Woods Hole. These sections are denoted, respectively, sections 1, 2, 3, and 4 (from Schubert, 1990).*

mission. The ship's track had been planned so that the Gulf Stream crossing on section 4 would coincide with a GEOSAT pass. Unfortunately, because of equipment malfunction associated with the satellite's age, no altimeter data were received from GEOSAT during the pass.

This report describes the TTM2 instrument system, its usage during OC216, and preliminary results. The WHOI shipboard program, consisting of XBT, conductivity-temperature-depth (CTD), and ADCP observations, is summarized in a separate report by Joyce et al. (1991). The scientific results from the WHOI program have been published by Joyce et al. (1990), Kelly et al. (1991), and Shubert (1990). A further study in collaboration with Joyce is planned.

## 2. INSTRUMENTATION

### 2.1 TTM2

#### 2.1.1 EM interpretation

The purpose of the towed transport meters (TTM and TTM2) is to determine the motionally induced electric field in the ocean. This measurement is combined with vessel motion, in this case determined using LORAN-C, to obtain  $\bar{v}^*$ , the electrical measure of the vertically averaged velocity. The quantity  $\bar{v}^*$  is usefully close to  $\bar{v}$ , the vertically averaged, or barotropic, velocity (Sanford, 1986).

TTM2 determines the longitudinal, or along-track, motionally induced electric field (the so-called GEK configuration, von Arx, 1950) by measuring the voltage between electrodes connected to the ocean through two saltwater-filled tubes, or salt bridges. This measurement corresponds to the cross-track velocity component. The observed signals are the combination of the motion of the towed instrument, its orientation, and the motion of the surrounding water. The voltage-to-velocity interpretation is based on the simple relationship derived from the physics of motional induction and influences due to the sensor's geometry.

According to Sanford (1971), the solution for the horizontal electric field is

$$\nabla_h \phi = \bar{v}^* \times \mathbf{k} F_z - \mathbf{J}^* \sigma^{-1}, \quad (1)$$

where  $\phi$  is the electrostatic potential,  $\nabla_h$  is the horizontal gradient operator ( $= \frac{\partial}{\partial x} \mathbf{i} + \frac{\partial}{\partial y} \mathbf{j}$ ),  $\mathbf{i}$ ,  $\mathbf{j}$ ,  $\mathbf{k}$  are unit vectors in magnetic east ( $x$ ), magnetic north ( $y$ ), and vertical ( $z$ ) directions,  $\mathbf{J}^*$  denotes nonlocal electric currents (usually negligible), and  $\sigma$  is electrical conductivity.

The ambient horizontal electric field is equal to the vertically averaged, conductivity weighted velocity. In fact, it is convenient to refer to the ambient horizontal electric field as being produced by an apparent barotropic velocity,  $\bar{v}^*$ ,

$$\bar{v}^* = \frac{\int_0^{-H} \sigma v d\xi}{\int_0^{-H_s} \sigma d\xi} \equiv \frac{\overline{\sigma v}}{\bar{\sigma}(1+\lambda)}, \quad (2)$$

where  $H$  is the ocean bottom depth,  $H_s$  is the lithospheric depth beneath which the electrical conductivity vanishes, and the electrical conductance ratio,  $\lambda$ , is defined as

$$\lambda = \frac{\int_0^{-H_s} \sigma d\xi}{\int_0^{-H} \sigma d\xi}. \quad (3)$$

A Reynolds decomposition of the conductivity velocity correlation in (2) gives

$$\bar{v}^* = \frac{\overline{\sigma v}}{\bar{\sigma}(1+\lambda)} = \frac{\bar{v}}{1+\lambda} + \frac{\overline{\sigma' v'}}{\bar{\sigma}(1+\lambda)} = \frac{\bar{v}(1+\gamma)}{1+\lambda}, \quad (4)$$

where  $\sigma$  and  $v$  have been expressed as vertical average ( $-$ ) and deviations ( $'$ ) and  $\gamma = \overline{(\sigma' v')}/(\bar{\sigma} \bar{v})$ . The term  $\bar{v}/(1+\lambda)$  is usually the dominant contribution to  $\bar{v}^*$ . The correlation term, represented by  $\gamma$ , is generally a small contribution; it is zero for barotropic flows ( $v' = 0$ ), for uniform electrical conductivity ( $\sigma' = 0$ ), or when  $\sigma$  and  $v$  are uncorrelated. However, in deep baroclinic flows such as the Gulf Stream,  $\gamma$  can be larger.

### 2.1.2 System configuration

Figure 2 shows two views of the TTM2 tow body and the towing configuration during OC216. A block diagram of the TTM2 electronics is presented in Figure 3.

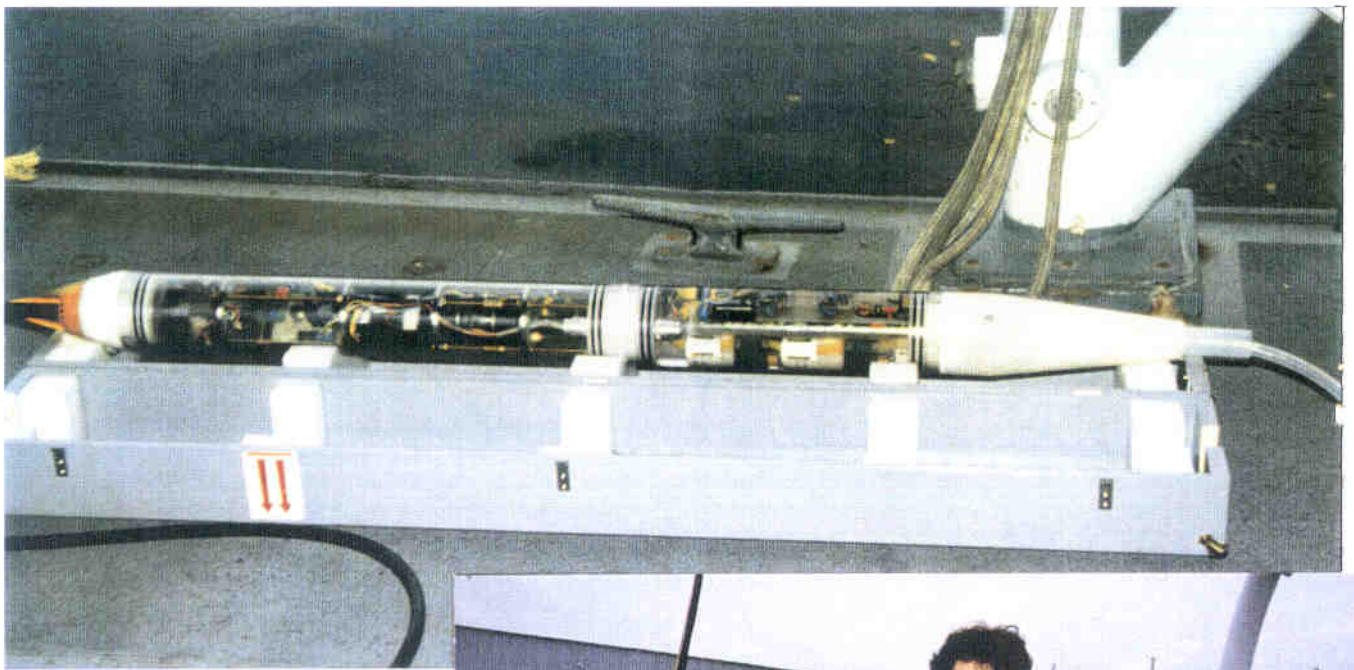

(a)



(b)

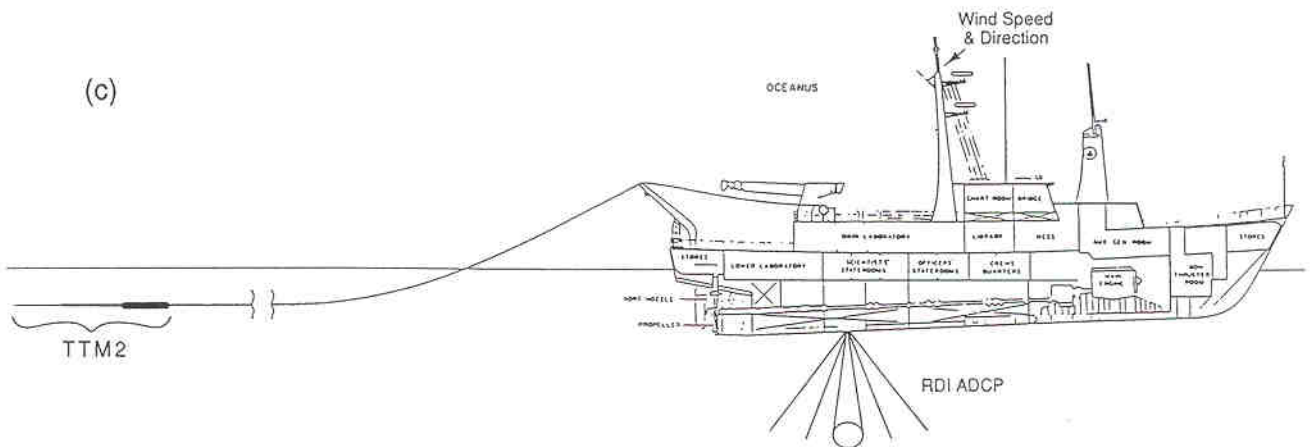

(c)

Figure 2. TTM2 tow body and towing configuration. (a) Tow body in cradle. (b) Jim Osse holding tow body. (c) Sketch of towing configuration during OC216.



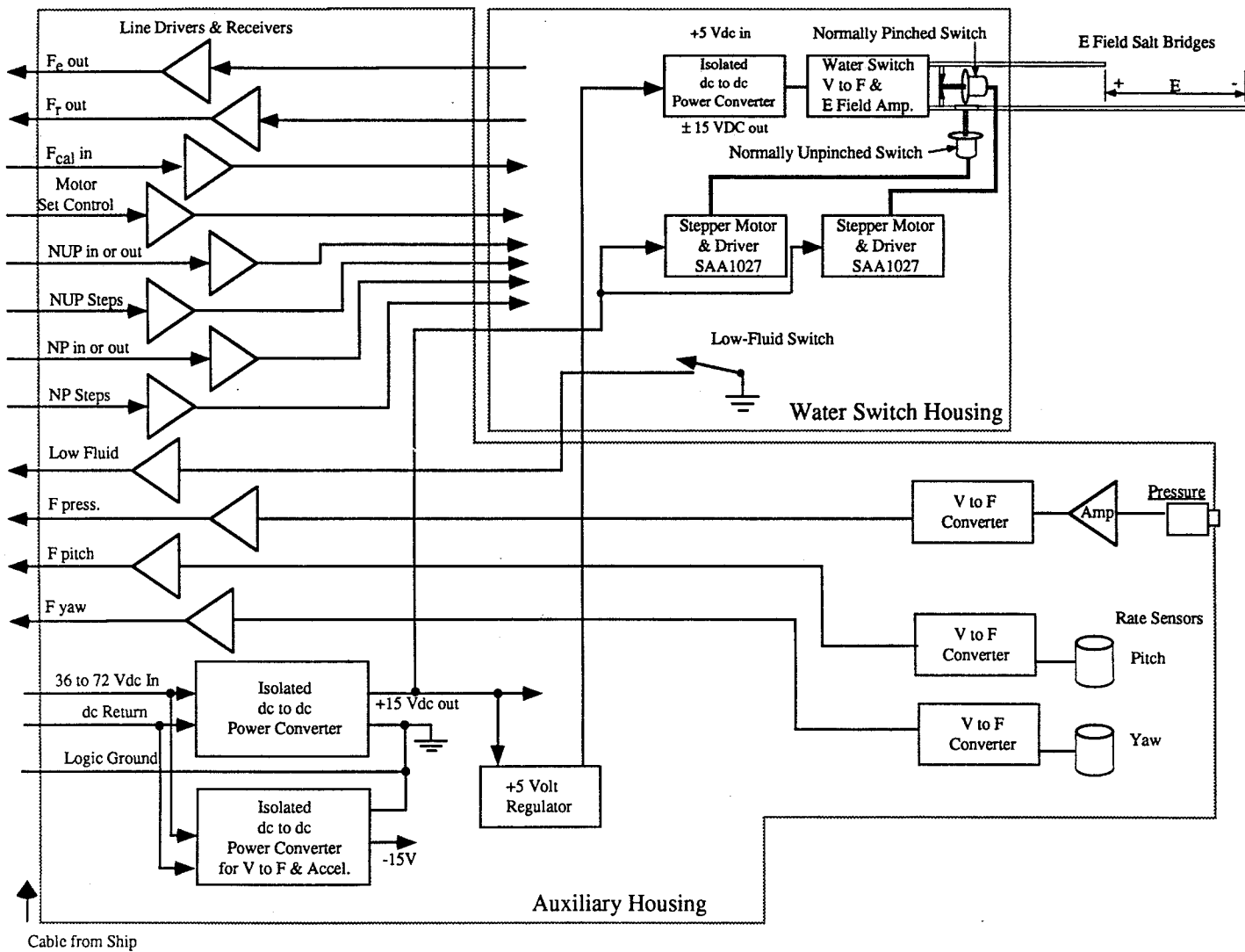

Figure 3. Block diagram of TTM2.

The TTM2 instrument system consists of the towed body (including two salt bridges), a rope drogue, a 20-conductor, polyurethane-jacketed, Kevlar tow cable, a winch, an APL-built deck box, and a data-acquisition computer (Figure 4). A small plastic assembly called the spider keeps the longer, thinner salt-bridge tube centered inside the shorter, fatter one.

The solenoids in the original TTM water switch caused significant electrode heating and thus drift in the electrode self-potential. TTM2 incorporates stepping motors to pinch the salt-bridge tubes. The stepping motors are energized only long enough to change the position of the pinch bars, whereas the solenoids had to be energized during the entire electrode check, 5 or 10 s. For 0.5 to 1 s during each 30-s data cycle, the stepping motors unpinch both tubes, allowing some new seawater to move into the tubing system. Although new water upsets the electrodes, it is more important that the tubes contain water with the same temperature and dissolved gas content as the local water to reduce the possibility of bubbles forming in the tubes. Bubbles would break the seawater path and render the instrument useless, requiring operator interaction to flush the bubbles from the tubing.

Some water is lost from the tubes during recovery, requiring that the tubes be refilled before the unit is deployed again.

The data cycle for TTM2 is approximately 30 s long. TTM2 samples the ocean for 20 s, performs a check to determine electrode offset for 5 s, and spends the rest of the time switching between states.

The TTM2 data-acquisition system is similar to that used for the TTM, described in detail by Dunlap et al. (1990). The data-acquisition computer used on OC216 was a Hewlett Packard HP-9020A. The TTM deck box (Figure 5) was connected to the HP-9020A computer via an RS-232 serial interface. Peripherals attached to the HP-9020A included an HP-7958B (152 Mbyte) hard disk for data storage, an HP-9144A (65 Mbyte) cartridge tape drive for data archival, and an HP-9872T plotter for hardcopy display. The program *sttmget* was used for data acquisition. Data displays included a 1-hour display

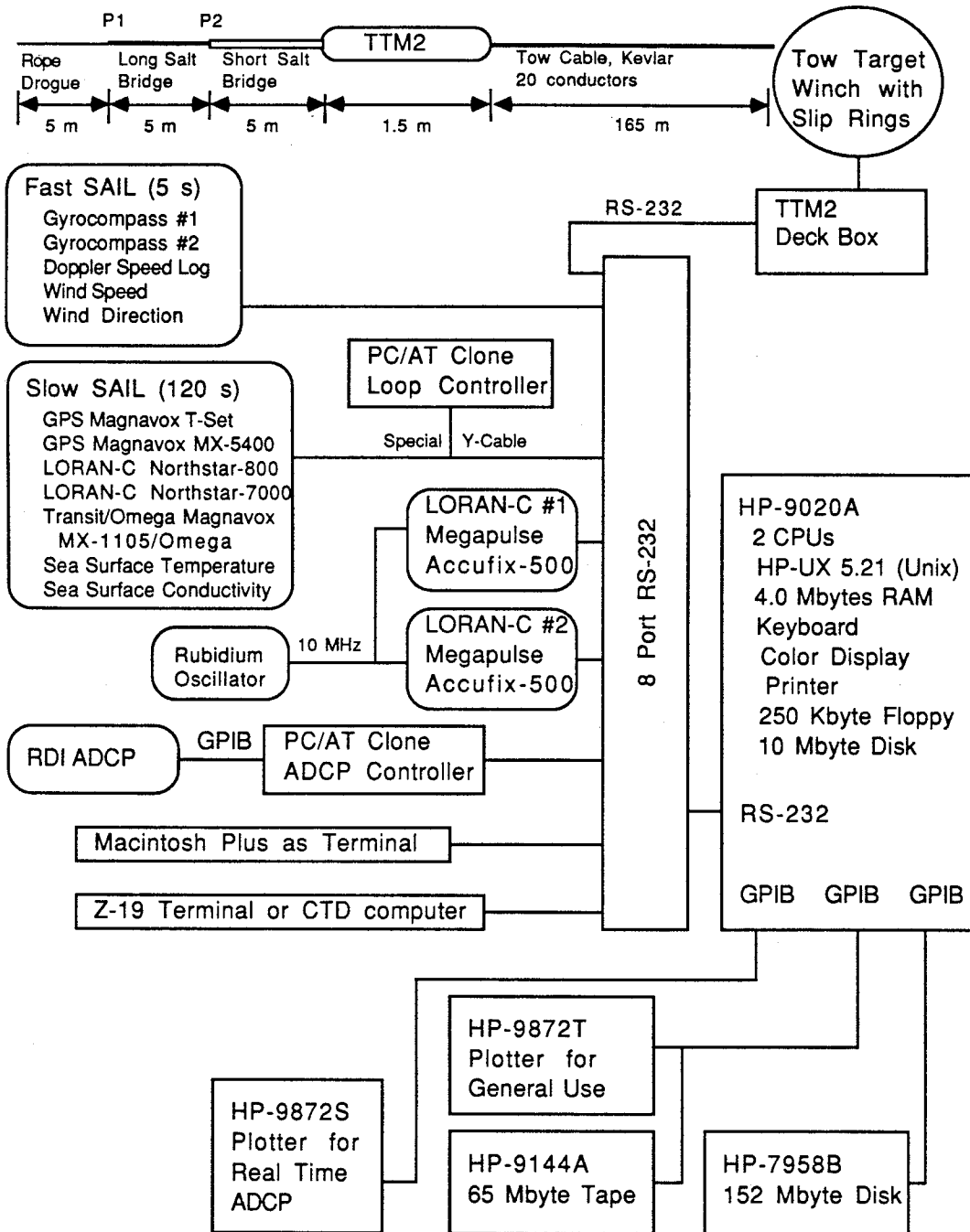

Figure 4. Configuration of TTM2 data-acquisition system.

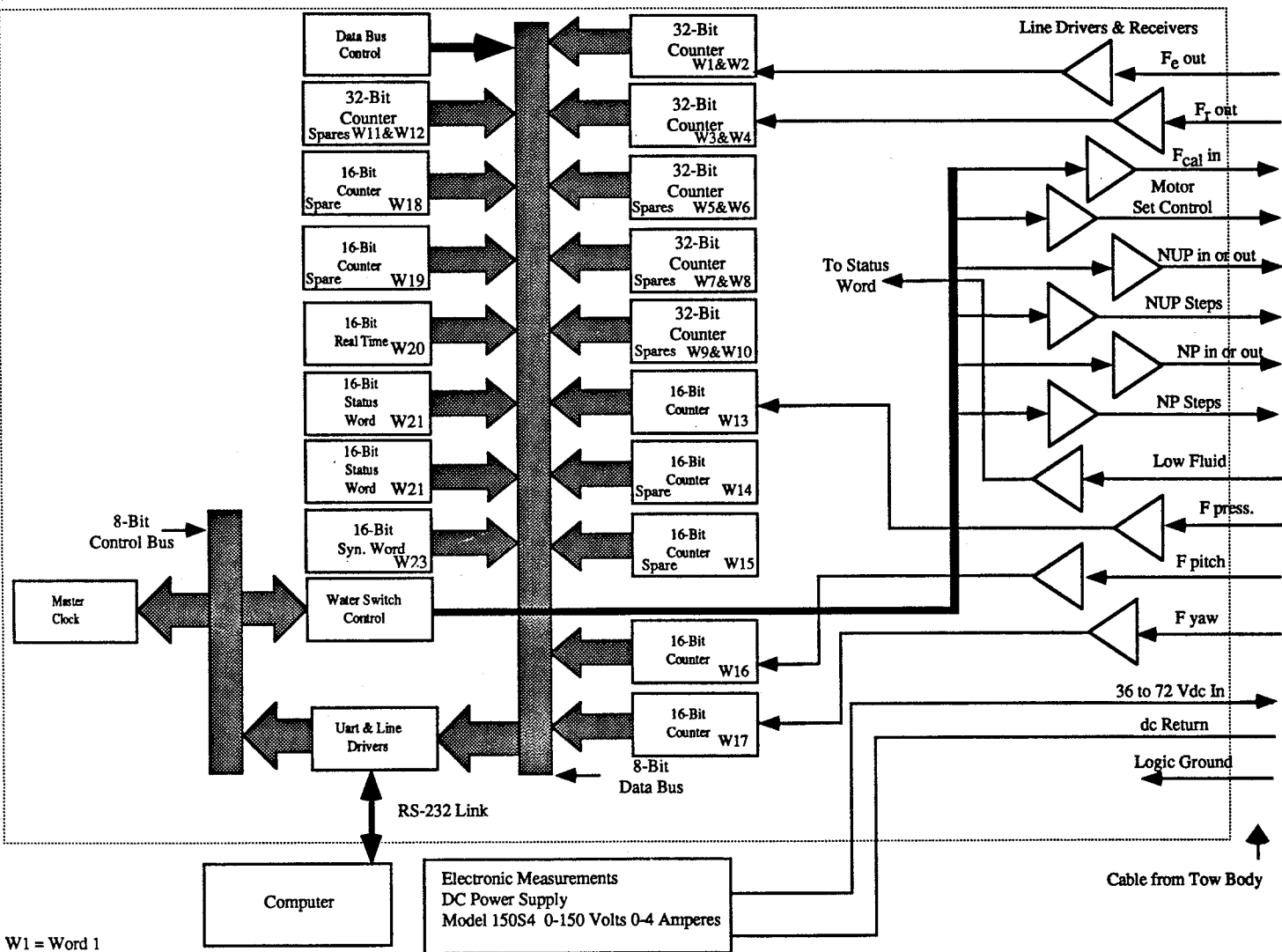

Figure 5. Block diagram of TTM2 deck box.

on the HP-9020A CRT and a 4-hour overview on a Z-19 terminal. The program *sttmsho* was used to generate the 1-hour display, and the programs *sttmavg* and *rtsho* were used to create the 4-hour display.

### 2.1.3 System deployment

TTM2 was deployed nine times during OC216. The times and locations are shown in Table 1.\* Because of the rough weather (waves were breaking over the deck throughout the cruise), deployment and recovery were always done with the ship headed into the sea at a slow speed. The unit was towed nearly continuously, being retrieved only for repairs during section 1 and while CTD stations were occupied.

Table 1. *TTM2 deployment and recovery log, OC216.*

TTM2	Deployment <sup>a</sup>			Recovery		
	Time (UTC)	N. Lat.	W. Long.	Time (UTC)	N. Lat.	W. Long.
1	1 Dec 1255	39 29.76	69 02.90	1 Dec 1610	39 08.93	68 48.65
2	1 Dec 2142	38 40.59	68 28.98	7 Dec 0522	35 28.36	74 49.53
3	7 Dec 0659	35 28.31	74 48.40	7 Dec 0755	35 27.18	74 43.64
4	7 Dec 0932	35 28.74	74 40.81	7 Dec 1117	35 21.97	74 26.03
5	7 Dec 1310	35 23.32	74 23.24	7 Dec 1531	35 14.90	74 00.85
6	7 Dec 1740	35 16.16	74 00.74	7 Dec 2110	35 04.31	73 27.22
7	7 Dec 2340	35 05.77	73 25.20	8 Dec 0320	34 53.85	72 46.88
8	8 Dec 0605	34 53.16	72 47.43	10 Dec 0240	32 30.03	64 55.88
9	10 Dec 0458	32 32.96	64 58.12	13 Dec 0118	40 07.85	69 32.67

<sup>a</sup>All deployment and recovery locations were determined by LORAN-C, corrected using SAT-NAV fixes.

The winch used to deploy TTM2 was installed aft of the ladder on the 01 level of R/V *Oceanus*. The tow cable was fed from the winch through a large block installed on the starboard extension of the ship's A frame.

\*Note: Unless otherwise stated, all times mentioned in this report are Universal Coordinated Time.

Tests showed that the instrument towed straight only when a drag element, such as a rope drogue, was attached to the end of the longer salt bridge. A drogue consisting of 3/4-in. plaited, straight rope was used during the cruise. The initial drogue was 18 ft long and attached with vinyl electrical "88" tape. It lasted less than 6 days. A 15-ft long drogue was then attached with lacing twine.

Several calibration runs were made during the cruise—on 2, 9, and 12 December. The times are shown in Table 2. The runs were made to provide suitable measurements for determining system noise. Typically, calibration runs consisted of reciprocal transects along magnetic cardinal directions in areas of low oceanic variability so that opposite legs would observe the same ocean structure. The correlation between reciprocal traverses depends on the temporal and spatial variability of the ocean. Restricting motion to magnetic cardinal directions provides a data set that is easier to interpret without a loss of generality. The final OC216 calibration was executed in a frontal feature.

*Table 2. TTM2 calibration runs, OC216.*

Run Number	Date	Start Time (UTC)	End Time (UTC)	Section Number	Comments
1	2 December	1741	1745	1	TTM2 signal lost <sup>a</sup>
2	2 December	1948	2158	1	
3	9 December	1839	2039	3	
4	12 December	1759	1959	4	

<sup>a</sup>The signal from TTM2 was lost owing to an open wire caused by the tension exerted by the depressor. The depressor was subsequently removed. With less tension on the cable, the conductors closed.

## 2.2 Navigation

To measure the ship's velocities for combination with the EM velocities, we used a range-range LORAN-C system. The system, described by Dunlap (1989), consisted of two Megapulse Accufix-500 survey-quality receivers with a common Efratom rubidium frequency oscillator/time reference. The program *accuget* was used to acquire data from the Megapulse LORAN-C receivers. Each receiver had one *accuget* program running.

One LORAN-C antenna was mounted 10 ft above the railing on the port quarter of the 01 deck. The other was mounted on the catwalk between the stacks. During some extremely high winds and lightening storms, the signal-to-noise ratio decreased sharply for approximately an hour because of the large increase in noise caused by the lightening, wind, and rain. Otherwise, the LORAN-C data were of good quality.

Unfortunately, the data acquired from the Global Positioning System (GPS) during the cruise were not good. It was unclear during the cruise whether the problem was with the GPS receiver or with the GPS transmissions. Afterward, we learned that the GPS system was being adjusted at the time.

## 2.3 ADCP

An RD Instruments 150-kHz ADCP was available as part of the ship's scientific equipment. The ADCP system consisted of a hull-mounted transducer connected by cable to a deck unit in the main laboratory. An IBM-compatible computer was connected to the deck unit via a GPIB cable for data acquisition and storage. In addition, the ADCP data were transferred to the HP-9020A in real time, and profiles were displayed on an HP-9872S plotter (Figure 4). After the ship got under way, the ADCP was run continuously.

## 2.4 SAIL

The following data were acquired from the shipboard Serial ASCII Instrumentation Loop (SAIL): gyrocompass heading, ship's speed, GPS position, SATNAV (Satellite/Omega Navigator) position, relative wind speed (kn), relative wind direction,

Northstar LORAN-C position, sea-surface temperature, and sea-surface conductivity. The data were acquired on two SAIL loops, one with a refresh cycle of 5 s and one of 120 s. The controller for the slower SAIL system was an IBM PC/AT clone. Data were acquired by the HP-9020A in real time via an RS-232 "y" connection using the program *sailget*. The fast SAIL system was running the *sailpoll* program. Figure 4 includes a schematic of the SAIL system.

For 8 hours during section 1, the cabling for the fast SAIL system failed. The HP-9020A's alphanumeric display was not on, so the problem went undetected and 8 hours of data were lost. In hindsight, the HP-9020A alphanumeric screen should be left on whenever possible because all the acquisition program status messages are directed to it.

## 2.5 CTD Casts

Conductivity-temperature-depth data were acquired by the WHOI investigators using a Sea-Bird Electronics Seacat CTD. In all, eight casts were made. Water samples were also collected for determining sea-surface salinities.

## 2.6 XBT Drops

A single XBT hand launcher was used at either of two port-side stations. The XBTs were Sippican Inc. type T-7s, going to a depth of 760 m. XBTs were launched approximately once per hour except when the ship's speed was reduced by heavy weather. In all, 227 XBTs were launched.

During section 1, a few (~5%) of the XBT profiles were bad because TTM2, being about 1 minute behind the vessel, would cut the XBT wire when the XBT probe was at a particular depth. It had been anticipated that the XBT wire would sometimes be cut by the TTM cable, and APL provided two boxes of XBTs for this cruise to make up for the losses.

Shortly into section 2, the XBT sampling technique was modified so that before an XBT was deployed the ship slowed down and rounded into the wind. This was done both to reduce the chance of the XBT wire breaking on the TTM2 tow cable and also for personnel safety. (Rounding into the wind reduced the amount of water on the ship's fantail.) This greatly reduced the problem of wire breakage but did not eliminate it. Some XBT wire was still noted at the spider when TTM2 was recovered, and XBT wire was also found where the tow cable enters the tow body.

### 3. THE EXPERIMENT

#### 3.1 Section 1 (Woods Hole to Bermuda)

R/V *Oceanus* departed Woods Hole for section 1 at 1612 on 30 November 1989. Assembly of TTM2 began as soon as the ship was under way. We had planned to attach the TTM2 salt-bridge tubes on deck after the air temperature rose above freezing. However, this was not possible because of the extremely bad weather. When this became apparent, all TTM2 equipment was brought into the main laboratory and assembled there. Assembly was slow owing to the high sea state.

An ADCP calibration run was conducted from 0502 to 0632 on 1 December. The weather was still rough, and working on deck was prohibited while the ship was moving. At 1206, R/V *Oceanus* hove to, and the salt-bridge tubes on TTM2 were filled using a bucket and pulley. The procedure took 10 minutes. TTM2 was launched at 1255 at a ship speed of 1–2 kn. One person lowered the instrument while another kept the trailing tubes elevated. Excess cable was let out in the hope of creating enough drag to carry the instrument away from the boat quickly. However, at a speed of 1–2 kn, there was insufficient drag to pull out the cable. Later deployments were therefore made at 3 kn. (Deployment at 4 kn produced too much tension, >30 lb.) In all, 475 ft of cable was deployed in approximately 50 minutes. *Oceanus* then changed course to 129° and increased speed to 12.5 kn. At 12.5 kn, TTM2 towed at a depth of 1–2 m. No depressor was used on this deployment because of concern about snagging commercial fishing gear.

Data acquisition commenced at 1320. TTM2 was flushed for 3 minutes by opening (unpinching) the valves on both tube sections.

The first tow was terminated at 1540 because data were not being transmitted up the cable. It was also noted that the current to the instrument was excessive (2 A). R/V *Oceanus* hove to at 1610 on 1 December for recovery of the unit. The *Oceanus* got under way with TTM2 on board at 1642.

When the instrument was opened and tested, it was found that unplugging the angular-rate sensor fixed the problem. The unit was therefore put back together with the sensor disconnected. The sensor itself was left in the vehicle because removing it would have changed the ballasting. The angular-rate sensor is used to determine vehicle motion and is not critical to data interpretation.

At 2047 on 1 December, R/V *Oceanus* hove to for the second TTM2 deployment along section 1. This time, a depressor was attached to the tow cable with a nylon stopper 50 ft behind the ship. TTM2 was deployed at 2142.

At 1741 on 2 December, R/V *Oceanus* turned to 000° magnetic to commence the first TTM2 calibration run. At 1745 the TTM2 signal ceased. R/V *Oceanus* slowed and hove to at 1752, and the tow cable was partially reeled in. The outer urethane jacket of the tow cable was unbroken, but in one spot was pulled back over itself. An ohmmeter check disclosed lack of electrical continuity in one of the tow cable wires. The cause was thought to be stress produced by the depressor, which was subsequently removed. It had been used for 16 hours at 11 kn before the failure occurred. With the depressor removed, there was no tension and the conductors closed, providing a signal from the instrument. No subsequent electrical changes were made. After the depressor was removed, the damaged section of the cable was pulled back five turns onto the winch. All subsequent deployments and recoveries were done by hand; the cable was laid out on the deck and secured with line.

TTM2 was then redeployed at the end of 400 ft of cable. R/V *Oceanus* got under way at 1805 at a speed of 3.5 kn on a heading of 169°T and increased speed to 6.8 kn. A second TTM2 calibration run started at 1948. Two sets of reciprocal legs were done along cardinal magnetic headings (N, S, E, W), superimposing an "L-shaped" pattern on the cruise track (Figure 6a). The first set started at 2005 and was oriented north-south magnetic (northwest-southeast true), on a heading of 000° magnetic (345°T), at a speed of 8.5 kn. At 2023 R/V *Oceanus* turned to the right for the reciprocal heading of 180° magnetic (165°T, 8 kn). At 2055 the ship began the second set of reciprocal legs,

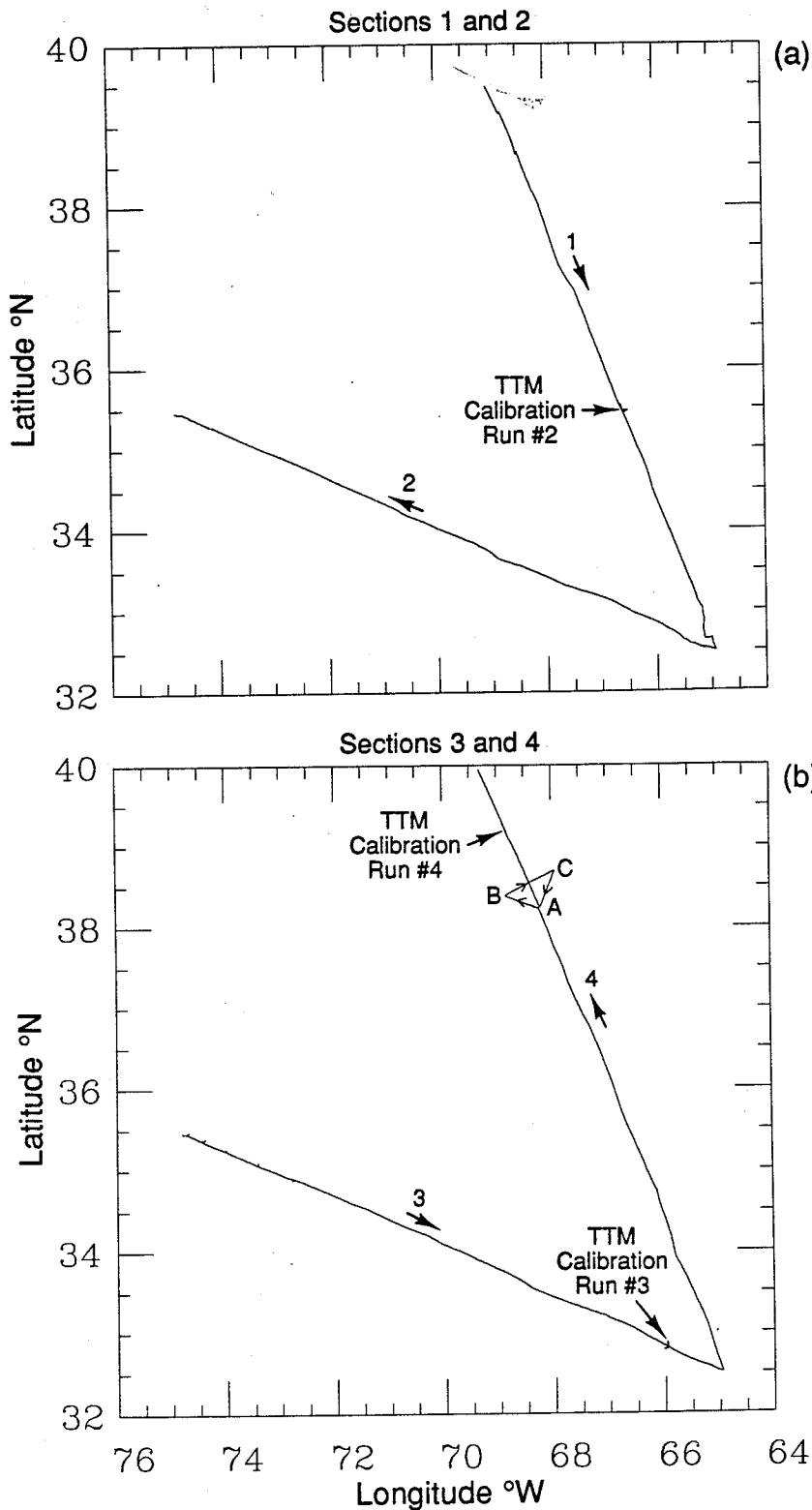

Figure 6. Vessel tracks for sections 1–4. (a) Tracks for sections 1 and 2 showing the location of TTM2 calibration run #2; (b) tracks for sections 3 and 4 showing the location of the Gulf Stream triangle pattern (points A-B-C) and TTM2 calibration runs (tracks are derived from LORAN-C data).

oriented east–west magnetic (northeast–southwest true), with a course change to  $090^\circ$  magnetic ( $075^\circ\text{T}$ ). The ship headed east for approximately 30 minutes and then executed a turn at 2126 for the reciprocal west heading of  $270^\circ$  magnetic ( $255^\circ\text{T}$ ). The calibration run ended at 2158, and R/V *Oceanus* resumed course ( $154^\circ\text{T}$ ) along section 1. TTM2 was towed continuously for the next 4 days. High winds (40 kn) were encountered on the starboard bow during 3 December, reaching 50 kn at 1500. A section log is given in Table 3.

Table 3. Section log, OC216.

Section Number	Date	Start Time (UTC)	Comment
1	30 November	1612	Woods Hole to Bermuda
2	4 December	0540	Bermuda to Cape Hatteras
3	7 December	0659	Cape Hatteras to Bermuda
4	10 December	0300	Bermuda to Woods Hole
	13 December	0800	End of cruise

### 3.2 Section 2 (Bermuda to Cape Hatteras)

About 10 n.mi. northwest of Bermuda, R/V *Oceanus* changed course to  $285^\circ$  to commence section 2. At the beginning of this section, it was hard to obtain good XBT profiles because the wire kept breaking. We therefore initiated a new launching technique in which the ship slowed and rounded into the wind while the XBT was launched. The TTM2 tow ended at the 200 m isobath at 0522 on 7 December 1989 in preparation for the first CTD cast off Cape Hatteras. The measured length of the TTM2 tubes upon retrieval was 4.98 m, the same as before the deployment.

### 3.3 Section 3 (Cape Hatteras to Bermuda)

Section 3 began with the deployment of TTM2 at 0659 on 7 December, following CTD cast 2. TTM2 was recovered before the next CTD cast, and was recovered and deployed before and after each CTD cast thereafter. A surface front was encountered between 1825 and 1835 on 7 December. TTM2 was deployed following CTD cast 7 at 0605 on 8 December, and R/V *Oceanus* was on course at 0621. At 1830 on 8 December, the tow cable was shortened by 6 ft to put the flex point at a different location.

Some equipment problems were encountered during this section. On 9 December, the computer that controlled the slow SAIL system stopped collecting data and had to be rebooted. About half an hour later, the ADCP PC clone stopped for approximately 30 minutes and was restarted at 1346. Then one of the LORAN stations went off the air around 1415, coming back on line at 1435.

Another "L-shaped" TTM2 calibration run (#3, Figure 6b) commenced at 1839 on 9 December. Again, two sets of reciprocal legs were done along the cardinal magnetic headings. The first leg was north along 000° magnetic (345°T), with a turn south at 1910 to 180° magnetic (165°T), followed at 2012 by a turn east along 090° magnetic (075°T). The calibration run ended at 2039, and R/V *Oceanus* turned for the next XBT site (171). TTM2 was recovered at 0240 on 10 December.

### 3.4 Section 4 (Bermuda to Woods Hole)

With TTM2 aboard, R/V *Oceanus* changed course for section 4. CTD cast 8 was taken, and TTM2 was deployed at 0458 on 10 December. R/V *Oceanus* continued on section 4 until 0150 on 12 December. At that time (point "A" in Figure 6b), the ship changed course to 280° and began a triangular pattern in support of the WHOI shipboard program. At 1130 R/V *Oceanus* returned to its original heading on section 4.

The fourth, and final, TTM2 calibration run commenced at 1759 on 12 December. This calibration run consisted of three legs overlying the section 4 track. The first leg

was northeast along  $333^{\circ}\text{T}$ . At 1819, the ship turned to a reciprocal heading of  $153^{\circ}\text{T}$  (speed 12.5 kn). At 1859, it turned back to the northwest for leg 3 along  $333^{\circ}\text{T}$ . The calibration run ended at 1959, and TTM2 was retrieved at 0118 on 13 December. The cruise ended on 13 December at 0800.

## 4. DATA PROCESSING

The TTM2, LORAN-C, and SAIL data all require extensive calibration, averaging, coordinate transformation, and combination to be useful. Other ancillary data such as the intermittent SATNAV fixes and GPS positions are required to calibrate the continuous LORAN-C data.

### 4.1 TTM2 Data

The theory describing the TTM2 data processing is described in detail by Dunlap et al. (1990). The primary processing programs used for the OC216 data were *sttmavg*, *nvbs*, and *filtlsq*. The near-surface ADCP data were used to correct for vessel leeway as described in Section 4.1.1. Corrections were also made for the conductivity-velocity correlation effect,  $\gamma$ , and the electrical conductance ratio,  $\lambda$ . After all correction factors were applied, the TTM2 data were converted to volume transport.

#### 4.1.1 Vessel leeway effects

Because of the action of the wind and seas, a ship drifts from its intended course while under way. Various methods were investigated to correct the TTM2 data for this vessel leeway. For the OC216 data set,  $\bar{v}^*$  was determined by

$$\bar{v}^* = v_{zports} - v_{ws}, \quad (5)$$

where  $v_{ws}$  is the cross-heading velocity component directly proportional to the water switch potential and  $v_{zports}$  is the cross-heading velocity component of the water (relative to the ground) at the depth of the electrode ports. If there is no vessel leeway,  $v_{zports}$  is simply the ship's velocity component as determined by LORAN-C and from the ship's gyrocompass. For strong beam winds and appreciable currents, however,  $v_{zports}$  is more complicated. For this work,  $v_{zports}$  was determined to be a function of two components: (1) the velocity of the water over the ground as calculated from the LORAN-C and gyrocompass data after correction using the ADCP data (usually the first or second ADCP

bin), and (2) the drift current estimated at the depth of the electrode ports. The drift current is assumed to be in the direction of the wind and proportional to wind speed, with different proportionality constants for different depths. Adjustments were made for the difference in depth between the ADCP data and the electrode ports.

#### 4.1.2 Conductivity-velocity correlation effect, $\gamma$

An appreciation of the magnitude of the conductivity-velocity correlation contribution can be had from Figure 7, which shows a velocity profile obtained by Sanford et al. (1985) with the Absolute Velocity Profiler (AVP) in the Gulf Stream only 200 km downstream from the Woods Hole–Bermuda line. In this profile, the correlation term,  $\gamma$ , amounts to 0.37. For a correction that is often thought to be of order 0.1, this is very large and illustrates the magnitude this term can reach in strong and baroclinic flows. The correlation term throughout the Gulf Stream is unknown, so it must be provided by a model. The correlation term depends on two main factors: water depth and flow strength. For predominantly first-mode baroclinic flow such as the Gulf Stream, the effect can be modeled by a simple function. The model we used is of the form

$$\gamma(x) = \gamma_0[H(x)] \frac{V_s(x)}{V_0}, \quad (6)$$

where  $\gamma_0$  is a function of water depth,  $V_s(x)$  and  $H(x)$  are the local surface velocity and water depth, respectively, and  $V_0$  is the maximum surface velocity. Our estimate of  $\gamma_0$  for Figure 7 is shown in Figure 8. The model is valid only for relatively deep regions, say deeper than 2000 m, where  $\gamma_0$  is large.

#### 4.1.3 Bottom conductance effect, $\lambda$

The model used for bottom conductance (Figure 9) was based on a three-layer conductivity structure: an ocean of depth  $H$ , a shallow sediment layer 1000 m thick with a conductivity half that of seawater (Filloux, 1987), and a deep sediment layer of diminishing thickness away from the shelf; the thickness of the latter layer was taken from a chart

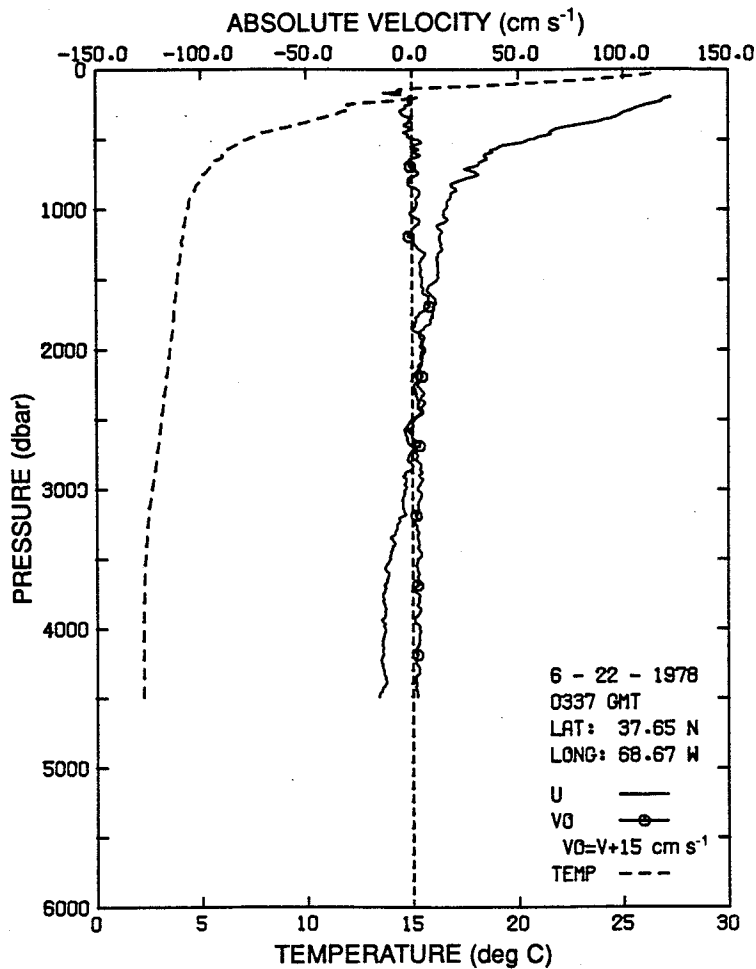

Figure 7. Velocity profile taken in the Gulf Stream by the AVP during POLYMODE. North (V) is plotted with a  $15 \text{ cm s}^{-1}$  offset, and temperature is converted to electrical conductivity. The conductivity-velocity correlation term amounts to a correction of 37%.

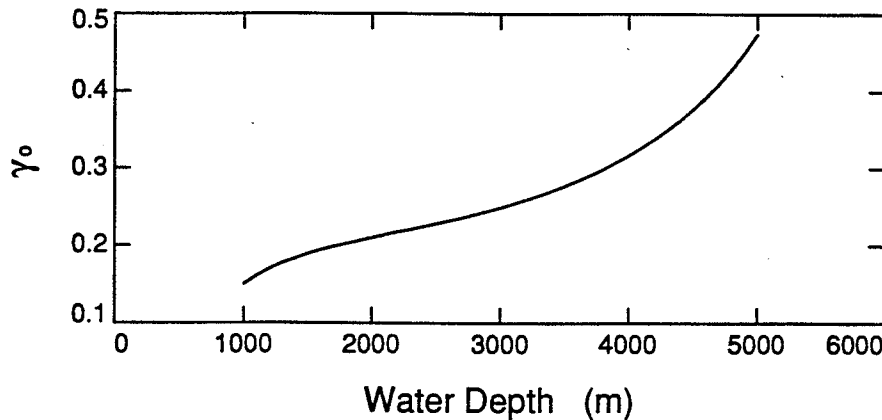

Figure 8. A model of the dependence of the conductivity-velocity effect as defined in Eq. (6) as a function of water depth. The model truncates the velocity and temperature (conductivity) structure shown in Figure 7 at the depth where  $\gamma_0$  is computed.

by Emery and Uchupi (1984) of sediment thickness in the region. The deep conductances are not known; based on the results of AVP profiling in the abyssal region during the Local Dynamics Experiment of POLYMODE, we chose a value of apparent conductivity ( $0.1 \text{ S m}^{-1}$ ) to yield  $\lambda = 0.07$ . The model illustrated in Figure 9 can be expressed as

$$\lambda(x) = \lambda_0 \frac{H_0 - h}{H(x) - h}, \quad (7)$$

where  $\lambda_0$  and  $H_0$  are the conductance ratio and water depth in the abyssal region and  $H(x)$  is the actual water depth along the track;  $\lambda$  was determined and  $h$  is a constant (of the order of 100 m) chosen to fit the model shown in Figure 9. Because the Gulf Stream is primarily in water deeper than 3000 m, the bottom conductance effect is of the order of 0.1.

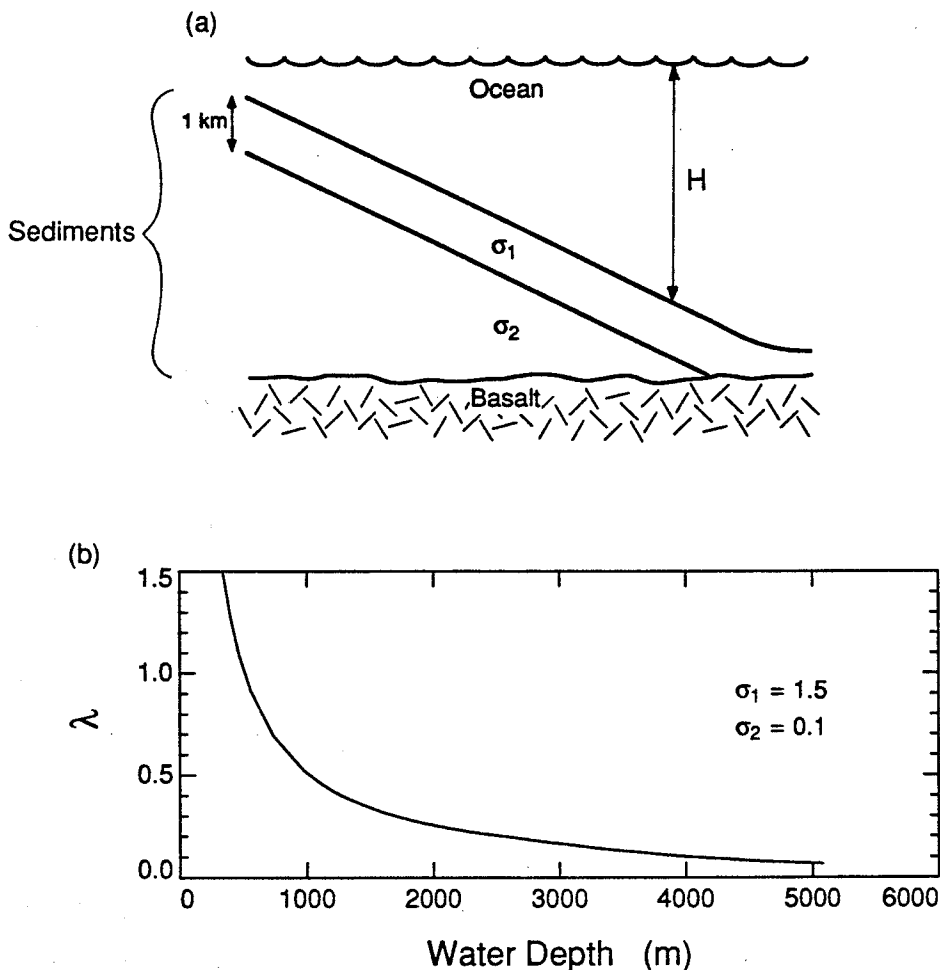

Figure 9. A model for sediment thickness and electrical conductivity. Panel (a) depicts a shallow, 1-km thick sediment layer with an apparent electrical conductivity ( $\sigma_1$ ) about half that of seawater ( $1.5 \text{ S m}^{-1}$ ) and an underlying sediment layer of diminishing thickness away from the shelf that has a conductivity ( $\sigma_2$ ) of only  $0.1 \text{ S m}^{-1}$ . Zero conductivity is assumed for the deep basalt layer. Panel (b) shows the modeled bottom-conductance effect,  $\lambda$ , as a function of water depth.

#### 4.1.4 Conversion of TTM observations to volume transport

The models for  $\gamma$  and  $\lambda$  provide the means for converting  $\bar{v}^*$ , the observed EM-derived vertically averaged velocity, into an estimate of  $\bar{v}$ . That is,

$$\bar{v}(x) = \frac{1+\lambda(x)}{1+\gamma(x)} \bar{v}^*(x). \quad (8)$$

## 4.2 Navigation Data

### 4.2.1 LORAN-C

The LORAN-C data were processed to obtain the east and north components of the velocity of the ship with respect to the ground as described by Dunlap (1989). The position of the ship must also be determined to obtain the correct geometry for the velocity computation. The formulas for determining the position are given by Collins (1980).

The two LORAN-C receivers, with a common external rubidium oscillator, provide the distance of the ship from the master station as well as the time differences to the secondary stations. The ranges to the secondaries can be easily determined by knowing the stations' positions and coding delays.

For each receiver, the range data for each station are fit to a straight line with least-squares techniques. This results in a mean range and a range rate for each station. The velocity is obtained from the rate of change of the LORAN-C ranges in the differentiated circular position formulas. These fits were done with 5 minutes of data from the LORAN-C receivers, which were sampled every 5 s. The purpose of the rather high sample rate is to obtain as much averaging as possible to reduce the noise.

The above means were used with an initial position estimate in a two-dimensional least-squares fit described by Collins (1980) to iteratively update the initial position and obtain a new position. Each mean defines a line of position; two lines are required to obtain a position at their crossing. If more than two lines of position are available, they

can be used together to obtain an average position which is the best fit of several crossings. Similarly, the time rates of change are used in the differentiated form of the position formulas to obtain velocity.

Corrections for oscillator drift, lane jumps and additional secondary phase factors were made using SATNAV fixes.

The program *lcavg* was used to process the LORAN-C data.

#### 4.2.2 Ship's heading

The ship's heading data were taken from the fast SAIL system, which was sampled at 5-s intervals, and averaged with least-squares fits over the same interval as the LORAN-C data. The sampling rate is high so the ship's yaw can be averaged and thus removed to provide a good estimate of the average heading.

The heading obtained from the ship's Sperry Mk 37 gyrocompass was used to rotate the east and north components of the ship's velocity as determined from the LORAN-C data into components transverse and longitudinal to the ship. The gyrocompass error was usually about  $1^\circ$  to  $2^\circ$ .

#### 4.3 ADCP Data

ADCP data were collected with the *rdaq* program via the serial connection to the PC/AT computer used with the ADCP. Color waterfall plots of ADCP data were created using the computer programs *rdgpl* and *gpl*. To correct for vessel leeway, the program *rdcom* was used in conjunction with the program *nvbs*.

## 5. PRELIMINARY RESULTS

We towed TTM2 along four sections: (1) from the shelf break south of Cape Cod to Bermuda, (2) from Bermuda to Cape Hatteras, (3) from Cape Hatteras to Bermuda, and (4) from Bermuda back toward Woods Hole. As seen in satellite imagery prior to the cruise (Figure 10), the Gulf Stream was undergoing strong meandering. The meander crossed the Bermuda–Woods Hole line (section 4) at three locations. Figure 11 shows the surface flow determined from LORAN-C data, the TTM2 observations of electric field, and the resulting estimates of  $\bar{v}^*$  for this section. The ship encountered what appears to be a large surface eddy about 130 km northwest of Bermuda and then crossed the meandering Gulf Stream three times. At approximately 500 km, a northeastward jet was entered and the barotropic signal increased. Soon the vessel crossed out of this jet and entered an equally strong southwestward feature with strong but narrow barotropic motions. Finally, the climatological Gulf Stream was crossed, producing a signal looking much like the earlier crossing of the first northeastward jet. The barotropic signal is weaker and broader than the corresponding surface value of the baroclinic flow.

Figure 12 shows the estimates of volume transport for section 4 along with the temperature isotherms determined from the hourly XBT drops. The same volume transport is observed at each crossing of the meandering Gulf Stream. These observations support a model in which the Gulf Stream flow is vertically coherent, and transport and surface expression move together as if the stream were a vertical ribbon undergoing compression and meandering.

Section 3 consisted of hourly XBT profiles and several CTD casts to the bottom along the Cape Hatteras–Bermuda line. The CTD and XBT data were converted to density (the latter using a T/S relation according to the method of Joyce et al., 1988). Geostrophic velocities were calculated, and the ADCP and LORAN-C data were used to establish reference velocities. The volume transport estimated from the XBT data is compared with our EM-derived determinations in Figure 13. The EM observations have been adjusted for  $\gamma$  and  $\lambda$  as discussed in Sections 4.1.2 and 4.1.3.

Across the climatological Gulf Stream (~ 50–200 km on the figure), the two observations are nearly equal in form and magnitude. This is a surprising result. Before these observations, the predictions were that the transport over the upper 760 m would be only a portion of the total volume transport, say 75% or so. These data indicate there is little net transport below 760 m, the maximum depth of the XBTs. Eight CTD stations were taken to the seafloor, most in the Gulf Stream. The transport curve based on the CTD section, adjusted to agree with absolute ADCP profiles in the upper ocean, is somewhat different in form, but not in ultimate magnitude, from the other two, more continuous measurements.

There are a couple of important points about the flow outside the Gulf Stream. Between 250 and 450 km, the TTM observed transport fluctuations of 50 Sv without much or any baroclinic (i.e., geostrophic) signal. Thus this feature would go undetected when using only upper-ocean observations. Beyond 500 km is another feature which has both deep and upper-ocean transports. The former is a cyclonic transport of over 150 Sv; the latter is also cyclonic but is only 40 Sv. Here, again, the upper-ocean observations are not representative of the motion of the total water column. Moreover, the strengths of these flows, whether eddy or mean, are greater than that of the Gulf Stream.

# OCEANUS 216

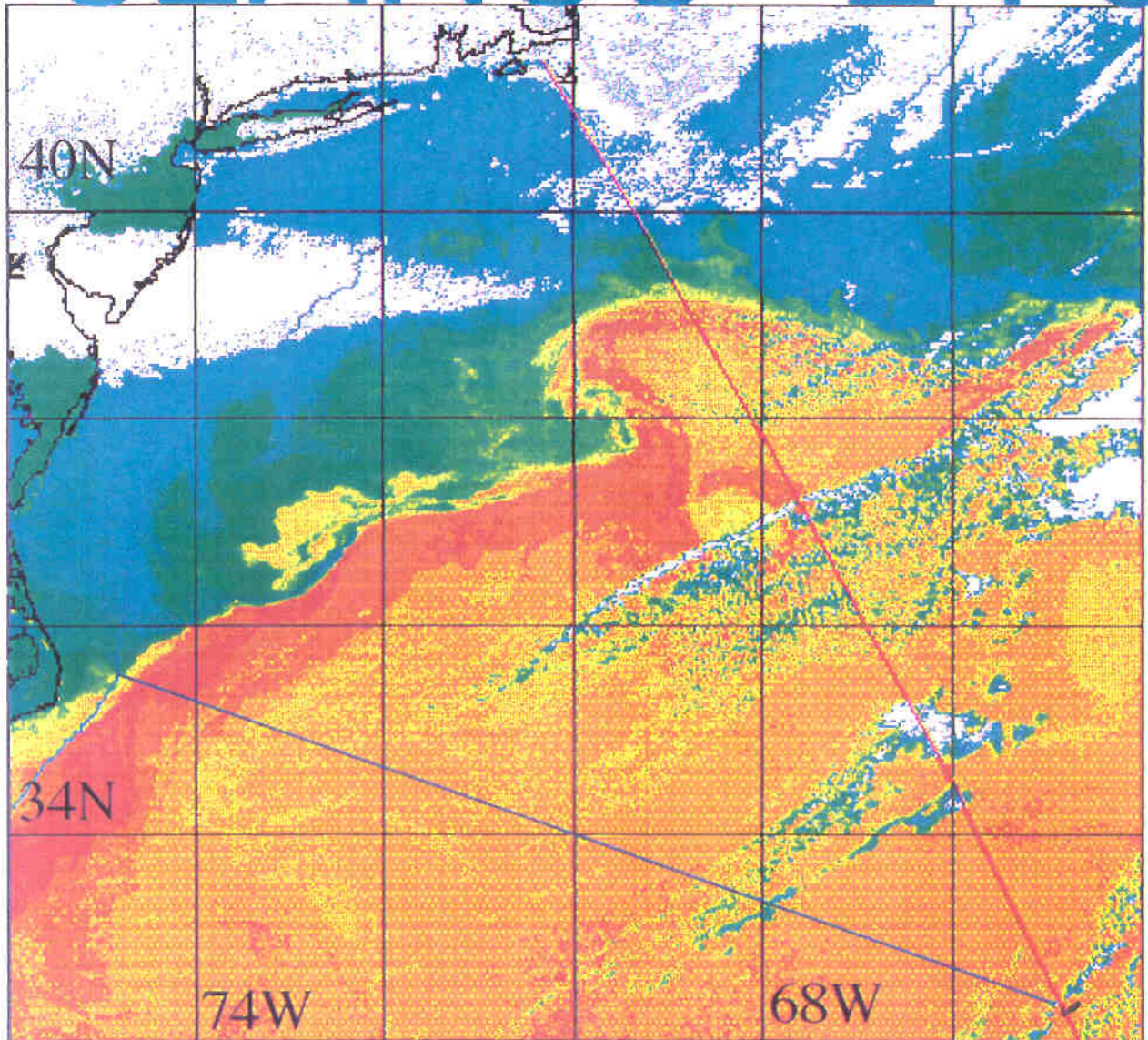

Figure 10. Infrared satellite image of the Gulf Stream region on day 316 (10 November 1989). Between Bermuda and Cape Hatteras (sections 2 and 3), R/V Oceanus followed the track shown in blue. Between Woods Hole and Bermuda (sections 1 and 4), it followed the GEOSAT ground track shown in red.



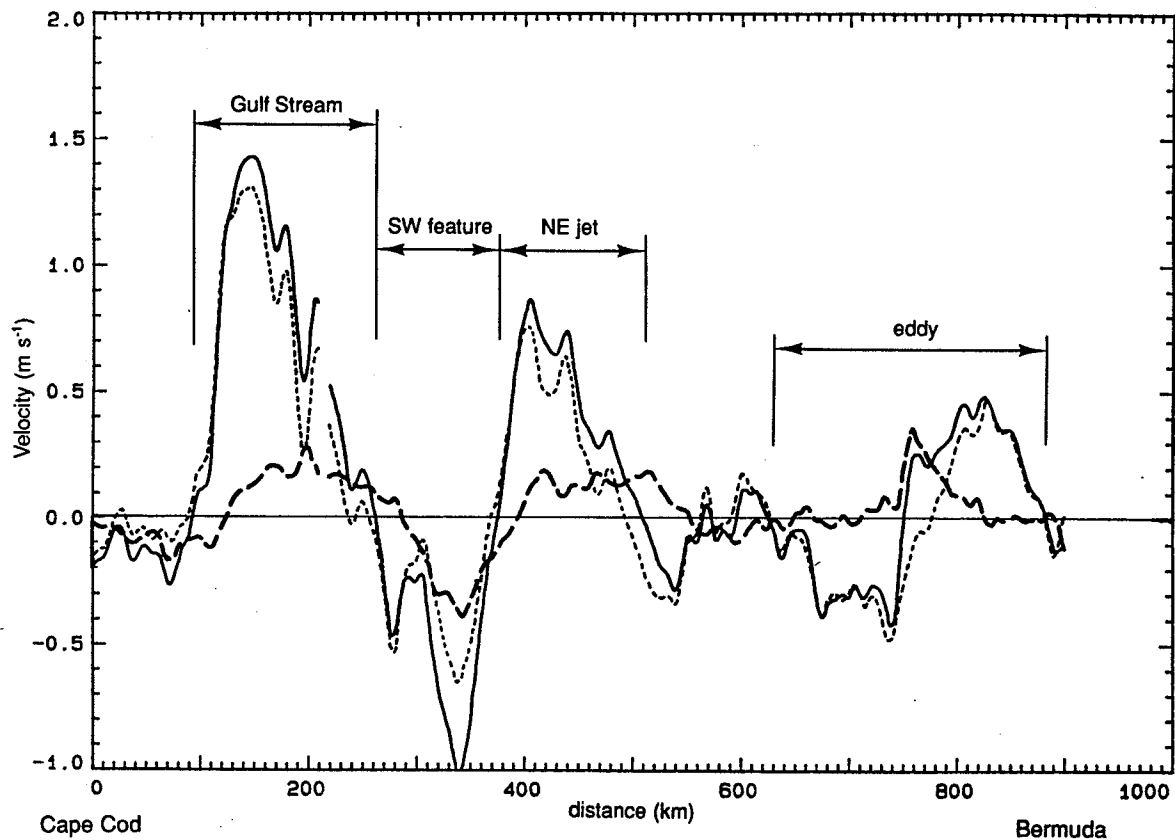

Figure 11. Velocities determined along section 4 from Bermuda to the continental shelf south of Cape Cod. The solid line is the surface velocity component normal to the ship's heading, and the short-dash line is the TTM2 electric measurement converted to velocity; the long-dash line is the difference. The difference after small corrections for vessel leeway is  $\bar{v}^*$ .

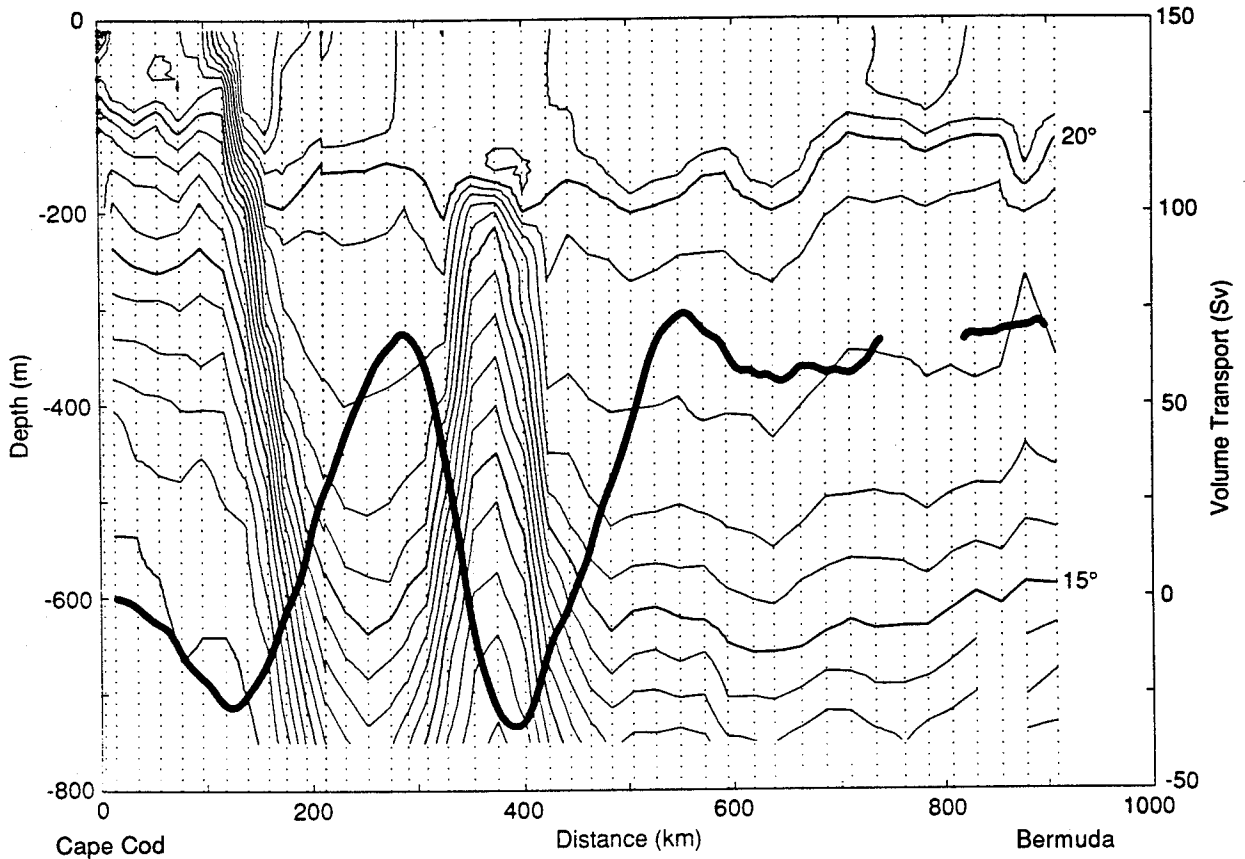

Figure 12. Isotherm depths (contour interval  $1^{\circ}\text{C}$ ) along section 4 from Bermuda to the continental shelf south of Cape Cod and volume transport (thick solid line) derived from TTM2 and navigation observations. The isotherms indicate multiple crossings of the Gulf Stream because of its strong meandering; nearly identical volume transport was observed on each crossing.

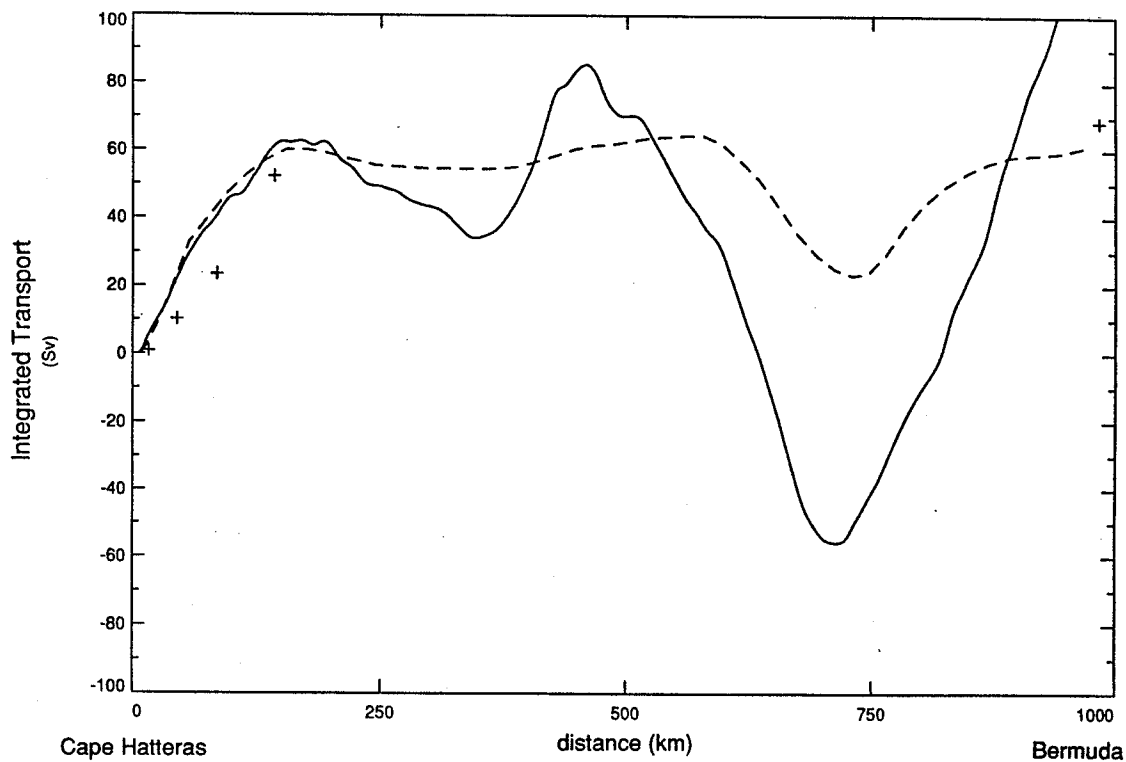

Figure 13. Comparison of three estimates of volume transport across the Gulf Stream offshore of Cape Hatteras during section 3. The solid curve is the volume transport derived from TTM2; the dashed curve is that derived from a simultaneous XBT section (using a T/S relation); the pluses denote volume transport based on the eight CTD stations (stations 2 and 7 were omitted because of instrument malfunction). Each determination uses LORAN-C and ADCP observations to provide reference velocities. The XBT and TTM2 transport estimates do not differ significantly in the Gulf Stream but show large differences offshore from the stream.

## 6. DISCUSSION

*Oceanus* Cruise 216 was a successful demonstration of our approach under extreme weather conditions—winds to 50 kn and seas to 30 ft. This is the first time TTM2 had to contend with such large surface waves.

The severe weather conditions presented the opportunity to demonstrate the usefulness of a towed instrument that can be handled by a single person. Other over-the-side work would have been difficult, but the TTM2 could be prepared while the ship was hove to. Once in the water, the instrument had to be recovered only once because of instrumentation problems.

At first, we used a depressor to pull down the cable and keep TTM2 deeper than 10 m. We had to abandon this approach when the depressor damaged the tow cable. Without the depressor, the unit remained within several meters of the sea surface without any apparent degradation of its performance. Of course, large surface waves had to be averaged out, but 5-minute averaged values were quite stable and devoid of significant wave contamination. Cable with a lead core could be used in place of the depressor to get TTM2 deeper.

The issue of vessel leeway needs more work, but our windage correction is tightly correlated with the transverse ship motion determined from the ADCP data.

It is clear that an instrument such as TTM2 could be easily deployed from volunteer observing ships and towed across ocean basins without intermediate recovery or refurbishment. Such transoceanic sections would provide the opportunity to acquire much needed data to study heat transport and circulation and their effects on global climate.

## 7. REFERENCES

- Collins, J., 1980 (revised): Formulas for positioning at sea by circular, hyperbolic, and astronomic methods. Technical Report NOS-81, National Oceanic and Atmospheric Administration, National Ocean Survey, Coastal Mapping Division, Rockville, MD.
- Drever, R. G., J. H. Dunlap, S. B. Hooker, M. A. Kennelly, T. B. Sanford, and G. L. Welsh, 1988: R/V *Endeavor* Cruise 155: Observations and preliminary results. APL-UW 8714, Applied Physics Laboratory, University of Washington, Seattle, WA.
- Dunlap, J. H., R. G. Drever, G. L. Welsh, T. B. Sanford, and M. A. Kennelly, 1990: The Towed Transport Meter: A new barotropic current meter. APL-UW 9007, Applied Physics Laboratory, University of Washington, Seattle, WA.
- Dunlap, J. H., 1989: Accurate determination of ship's velocity using LORAN-C, *Oceans* 89, 3, 860-862. IEEE Publ No. 89CH2780-5.
- Emery, K. O., and E. Uchupi, 1984: *The Geology of the Atlantic Ocean*, Springer-Verlag, New York.
- Filloux, J. H., 1987: Instrumentation and experimental methods for oceanic studies, in *Geomagnetism*, Vol. 1, J. A. Jacobs, editor, Academic, London, pp. 143-248.
- Joyce, T. M., J. A. Dunworth, D. M. Shubert, M. C. Stalcup, and R. L. Barbour, 1988: Application of acoustic-Doppler current profiler and expendable bathythermograph measurements to study the velocity structure and transport of the Gulf Stream. WHOI-88-42, Woods Hole Oceanographic Institution, Woods Hole, MA., 27 pp.
- Joyce, T. M., K. A. Kelly, D. M. Shubert and M. J. Caruso, 1990: Shipboard and altimetric studies of rapid Gulf Stream variability between Cape Cod and Bermuda. *Deep-Sea Res.*, 37(6), 897-910.
- Joyce, T. M., M. C. Stalcup, R. L. Barbour, J. A. Dunworth, and D. M. Shubert, 1991: Cruise summaries of *Oceanus* cruises 205, leg 8, and 216. WHOI-91-07, Woods Hole Oceanographic Institution, Woods Hole, MA.
- Kelly, K. A., T. M. Joyce, D. M. Shubert and M. J. Caruso, 1991: The mean sea surface height and geoid along the GEOSAT subtrack from Bermuda to Cape Cod. *J. Geophys. Res.*, 96, 12,699-12,709.
- Sanford, T. B., 1971: Motionally induced electric and magnetic fields in the sea. *J. Geophys. Res.*, 76, 3476-3492.
- Sanford, T. B., 1986: Recent improvements in ocean current measurement from motional electric fields and currents. *Proc. IEEE Third Working Conf. on Current Meas.*, Air-*lie*, VA, 22-24 January, 65-76.

- Sanford, T. B., R. G. Drever, and J. H. Dunlap, 1985: An acoustic Doppler and electromagnetic velocity profiler. *J. Atmos. Oceanic Technol.*, **2**, 110–124.
- Sanford, T. B., R. G. Drever, J. H. Dunlap, M. A. Kennelly, M. D. Prater, and G. L. Welsh, 1988: The Towed Transport Meter (TTM) and its sea test on R/V *Thompson* Cruise 202. APL-UW 8713, Applied Physics Laboratory, University of Washington, Seattle, WA.
- Shubert, D. M., 1990: Shipboard and satellite observations of upper ocean velocity and transport variability in the Gulf Stream. MIT-WHOI Joint Program, M.S. thesis, 105 pp.
- von Arx, W. S., 1950: An electromagnetic method for measuring the velocities of ocean currents from a ship under way. *Papers in Physical Oceanography and Meteorology*, **11**(3), 1–62, M.I.T. and Woods Hole Oceanographic Inst.