

Carderock Division Naval Surface Warfare Center

West Bethesda, Maryland 20817-5700

NSWCCD-50-TR-2007-039

Hydromechanics Department Report

December 2007

ACOUSTIC DOPPLER CURRENT PROFILER (ADCP) VELOCITY VERIFICATION EXPERIMENTS IN THE NAVY'S LARGE CAVITATION CHANNEL (LCC)

By
Dylan A. Chirichella



Carderock Division



20071226017

REPORT DOCUMENTATION PAGE			Form Approved OMB No. 0704-0188		
<small>Public reporting burden for this collection of information is estimated to average 1 hour per response, including the time for reviewing instructions, searching existing data sources, gathering and maintaining the data needed, and completing and reviewing this collection of information. Send comments regarding this burden estimate or any other aspect of this collection of information, including suggestions for reducing this burden to Department of Defense, Washington Headquarters Services, Directorate for Information Operations and Reports (0704-0188), 1215 Jefferson Davis Highway, Suite 1204, Arlington, VA 22202-4302. Respondents should be aware that notwithstanding any other provision of law, no person shall be subject to any penalty for failing to comply with a collection of information if it does not display a currently valid OMB control number. PLEASE DO NOT RETURN YOUR FORM TO THE ABOVE ADDRESS.</small>					
1. REPORT DATE (DD-MM-YYYY) 12-Dec-2007	2. REPORT TYPE Final		3. DATES COVERED (From - To) -		
4. TITLE AND SUBTITLE Acoustic Doppler Current Profiler (ADCP) Velocity Verification Experiments in the Navy's Large Cavitation Channel (LCC)			5a. CONTRACT NUMBER		
			5b. GRANT NUMBER		
			5c. PROGRAM ELEMENT NUMBER		
6. AUTHOR(S) Dylan Chirichella			5d. PROJECT NUMBER		
			5e. TASK NUMBER		
			5f. WORK UNIT NUMBER 04-1-5600-217-30		
7. PERFORMING ORGANIZATION NAME(S) AND ADDRESS(ES) AND ADDRESS(ES) Naval Surface Warfare Center Carderock Division 9500 MacArthur Boulevard West Bethesda, MD 20817-5700			8. PERFORMING ORGANIZATION REPORT NUMBER NSWCCD-50-TR-2007/039		
9. SPONSORING / MONITORING AGENCY NAME(S) AND ADDRESS(ES) Attn PMS 450 Commander Naval Sea Systems Command 1333 Isaac Hull Ave S.E. Wash. Navy Yard, D.C. 20376			10. SPONSOR/MONITOR'S ACRONYM(S)		
			11. SPONSOR/MONITOR'S REPORT NUMBER(S)		
12. DISTRIBUTION / AVAILABILITY STATEMENT Approved for public release; distribution is unlimited.					
13. SUPPLEMENTARY NOTES					
14. ABSTRACT The Resistance and Powering Division (Code 5200) of The Naval Surface Warfare Center, Carderock Division (NSWCCD) conducted verification experiments on a 20 degree Acoustic Doppler Current Profiler (ADCP) unit produced by RD Instruments (RDI) of San Diego, California. These experiments were conducted in the Navy's Large Cavitation Channel (LCC) located in Memphis, Tennessee. Although they have many other possible future uses, currently the ADCP units tested during this series are used to profile flow and determine speed through the water on ships during at-sea trials. The purpose of this Report is to present the accuracy of the ADCP units in determining speed through the water. Data collected with the ADCP units are compared to data collected by the LCC's Laser Doppler Anemometer (LDA) system, which provides highly accurate water velocity data. The experimental results indicate excellent agreement between the ADCP and LDA. Based on the experimental results, it is recommended that the ADCP is operated using water mode 12 and an ambiguity velocity of 700 cm/s during future sea trials. The experimental results indicate the ADCP agrees with LDA within +/-0.2 knots on average when these settings are used.					
15. SUBJECT TERMS Acoustic Doppler Current Profiler, Large Cavitation Channel, ADCP, LCC					
16. SECURITY CLASSIFICATION OF:			17. LIMITATION OF ABSTRACT	18. NUMBER OF PAGES	19a. NAME OF RESPONSIBLE PERSON
a. REPORT	b. ABSTRACT	c. THIS PAGE			Dylan Chirichella
UNCLASSIFIED	UNCLASSIFIED	UNCLASSIFIED	SAR	32	19b. TELEPHONE NUMBER (include area code) 301-227-7003

This page left intentionally blank.

CONTENTS

ABBREVIATIONS.....	vi
ENGLISH AND METRIC EQUIVALENTS	vi
ABSTRACT	1
ADMINISTRATIVE INFORMATION.....	1
INTRODUCTION.....	1
DESCRIPTION OF TEST FACILITY	2
DESCRIPTION OF ADCP.....	2
EXPERIMENTAL PROCEDURE.....	4
PRESENTATION AND DISCUSSION OF RESULTS.....	8
CONCLUSIONS.....	14
ACKNOWLEDGMENTS.....	14
APPENDIX A - EXPERIMENTAL AGENDA.....	15
APPENDIX B - LDA DATA.....	21
REFERENCES.....	29

FIGURES

1	Side and Top view of 20 degree Workhorse Monitor ADCP.	3
2	Cross section of LCC showing experimental setup of ADCP and LDA.....	5
B-1	Axial tunnel velocities at several axial positions as measured by LDA along the centerline of the LCC.....	25
B-2	Axial tunnel velocities at several vertical locations as measured by LDA at a 50 mm axial location.	26
B-3	Axial tunnel velocities at several vertical locations as measured by LDA at a 895 mm axial location.	27

TABLES

1	Bins and bin locations selected to compare to LDA data	6
2	Experiment results for 20 degree ADCP with beam 3 forward for several bin sizes.	12
3	Experiment results of 20 degree ADCP with beam 3 oriented 45 degrees to starboard for two bin sizes.....	12
4	Experiment results for 20 degree ADCP with beam 3 oriented 45 degrees to starboard and pitched 10 degrees.....	13
5	Experiment results for 20 degree ADCP with beam 3 oriented 45 degrees to starboard for several ambiguity velocities.....	13
A-1	As tested experimental agenda for ADCP testing in the LCC.	17
B-1	LDA data set inventory.	23

ABBREVIATIONS

The abbreviations used in this document are defined below.

ABBREVIATION	DESCRIPTION
ADCP	Acoustic Doppler Current Profiler
cm	centimeter
cm/s	centimeters per second
deg	degrees
kt(s)	knot(s)
LCC	Large Cavitation Channel
LDA	Laser Doppler Anemometer
m/s	meter per second
mm	millimeter(s)
RDI	RD Instruments
WV	Ambiguity Velocity

ENGLISH AND METRIC EQUIVALENTS

ENGLISH	METRIC
1 inch	25.400 millimeters (0.0254 meters)
1 foot	0.3048 meters
1 foot per second	0.3048 meters per second
1 knot	0.5144 meter per second
1 pound force	4.4480 newtons
1 degree (angle)	0.01745 radians
1 horsepower	0.7457 kilowatts
1 long ton	1.016 tonnes, 1.016 metric tonnes, or 1016.0 kilograms
1 inch water (60° F)	248.8 pascals

ABSTRACT

The Resistance and Powering Division (Code 5200) of The Naval Surface Warfare Center, Carderock Division (NSWCCD) conducted verification experiments on a 20 degree Acoustic Doppler Current Profiler (ADCP) unit produced by RD Instruments (RDI) of San Diego, California. These experiments were conducted in the Navy's Large Cavitation Channel (LCC) located in Memphis, Tennessee. Although they have many other possible future uses, currently the ADCP units tested during this series are used to profile flow and determine speed through the water on ships during at-sea trials.

The purpose of this report is to present the accuracy of the ADCP units in determining speed through the water. Data collected with the ADCP units are compared to data collected by the LCC's Laser Doppler Anemometer (LDA) system, which provides highly accurate water velocity data.

The experimental results indicate excellent agreement between the ADCP and LDA. Based on the experimental results, it is recommended that the ADCP is operated using water mode 12 and an ambiguity velocity of 700 cm/s during future sea trials. The experimental results indicate the ADCP agrees with LDA within +/- 0.2 knots on average when these settings are used.

ADMINISTRATIVE INFORMATION

This series of experiments were sponsored by PMS 450 under work unit number 04-1-5600-217-30.

INTRODUCTION

Acoustic Doppler Current Profilers (ADCPs) are an instrument capable of measuring a ship's speed through the water. with a high degree of accuracy. They have been used on several U.S. Navy ships during at-sea trials and have the potential to be used on many classes of ships in the future including submarines, displacement hulls, semi-planing hulls, high speed craft and others.

Until this series of experiments, ADCPs had not been compared to an accurate speed measurement at high speeds. This series of experiments was conducted to quantify the uncertainty of ADCP speed measurements and to determine the speed range the ADCP is capable of measuring. Water speed

through the tunnel was independently measured using the Large Cavitation Channel's (LCC) LDA system, which provides highly accurate data. The experiments were conducted up to the nominal maximum speed allowed by the test facility of 35 knots. The experiments ran from 13 July through 14 July 2004. This report contains the results of these experiments. The experimental agenda is presented in Appendix A.

Two ADCP units were tested during this series of experiments including a Workhorse Monitor with a 20 degree head and a Workhorse Navigator with a 30 degree head. Only a limited set of data was collected with the Workhorse Navigator and thus the data are not presented in this report. The data are available upon request of Code 5600.

DESCRIPTION OF TEST FACILITY

The Navy's Large Cavitation Channel (LCC) is a recirculating water test facility located in Memphis, Tennessee. Operational since 1991, the LCC is a variable pressure cavitation tunnel with low acoustic background levels. It is the largest of its type in the world, with a test cross section of 10 ft x 10 ft and a test section length of 46 ft. The LCC is capable of nominal flow velocities up to 35 knots with very low turbulence levels to conduct hydrodynamic and hydroacoustic evaluations of submarine and ship models. The LCC has the advantage of high Reynolds number model testing with the ability to test models up to 40 ft long. Uncertainty estimates of the test section pressure and velocity measurements have been evaluated and reported in Reference 1.

DESCRIPTION OF ADCP

Two ADCP units were tested during this series of experiments including a Workhorse Navigator with a 30 degree head and a Workhorse Monitor with a 20 degree head. Due to time constraints, only limited data were collected with the 30 degree Workhorse Navigator ADCP, thus only data for the 20 degree Workhorse

Monitor ADCP is presented in this report. Both units operate using the same physical mechanisms for measuring water velocity, as described below.

Figure 1 shows a side and top view of the Workhorse Monitor ADCP that was tested in the LCC. Each unit has a face with four transducer faces pointing outward at a defined angle (20 or 30 degrees for the units tested). The shaded region in the side view of Figure 1 represents a 15 degree cone around each beam which should be unobstructed. Each transducer face outputs an acoustic “beam” of sound waves into the water. A fraction of these sound waves are reflected back towards the unit, which receives these waves. The unit calculates the phase shift of the reflected waves and thus is able to calculate the velocity of the particles in the water. It is assumed that the particles are moving at the same velocity as the water, thus the water velocity is known. This process is conducted simultaneously for all four transducer beams which enable the unit to calculate velocities in the x, y, and z directions.

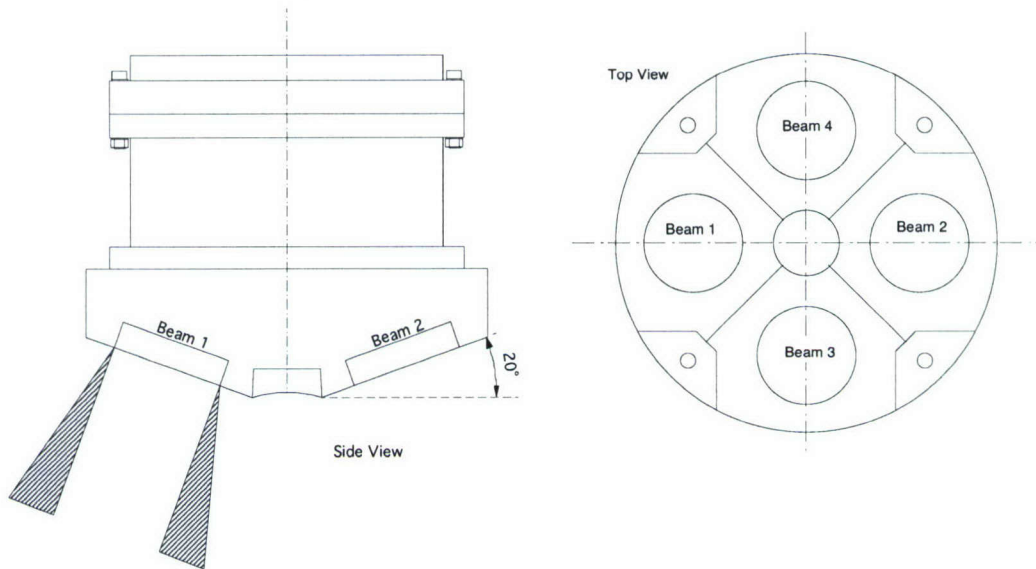

Figure 1: Side and Top view of 20 degree Workhorse Monitor ADCP.

EXPERIMENTAL PROCEDURE

Several parameters must be input by the user into the ADCP which effect the operation of the unit. The effect of several parameters were investigated during this series of experiments and include: bin size, ambiguity velocity, rotation of the unit relative to the flow, pitch angle of the unit, and water mode.

The ADCPs measure the velocities of particles within user defined distance ranges away from the unit, called "bins". There is also a region from the transducer face to some distance away from the unit that the unit cannot measure velocity. This region is necessary to allow the unit time to recover before reflected signals can be received. This is called the "blank after transmit" region. Both units during this series of experiments had a blank after transmit region of 20 cm vertically out from the head of the units. The ADCP measures the velocity of many particles within a particular bin, and averages these velocities to define the velocity for the bin.

Figure 2 below shows the cross section of the LCC with the 20 degree Monitor ADCP installed. The ADCP in Figure 2 is shown with beam 3 rotated about the z-axis 45 degrees to starboard (off the direction of the flow). The view in Figure 2 is looking downstream (water flow into the page), beam 3 is on the left. The bin regions are shown for a 30 cm bin size. The beam paths are shown as dark shaded regions. Measurements for a specific bin are made in the region of the beam contained within the bin region. For example, measurements for bin 1 would be made by the ADCP within the beams contained in the bin 1 region as shown in Figure 2. The lighter shaded regions show the region that should remain unobstructed around the beams as recommended by RDI. This region is defined by a 15 degrees cone around each beam. Also, the bold line near the center of the tunnel shows the vertical path of measurement points traversed by the LDA system. A more detailed description of these measurements will be presented later.

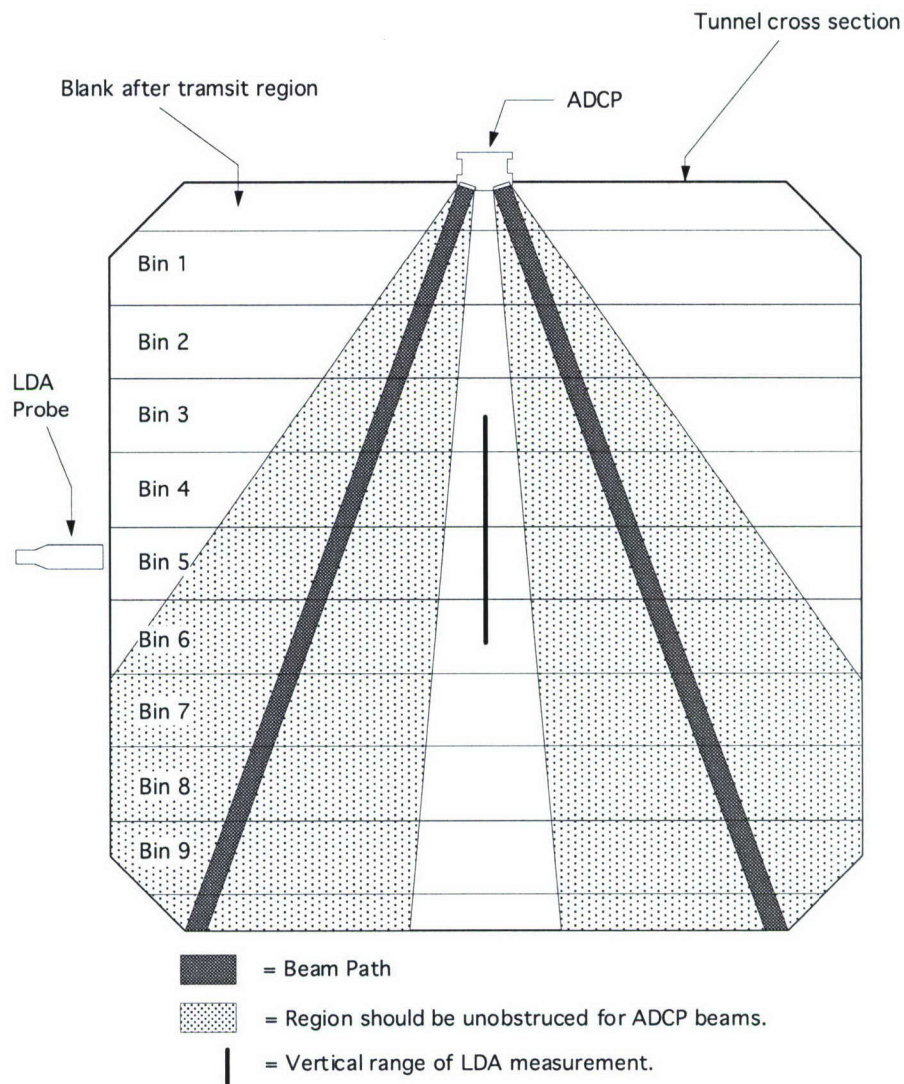

Notes: Bin distances shown are for 30 cm bin size.
Beams shown are for 20 degree ADCP head.

Figure 2: Cross section of LCC showing experimental setup of ADCP and LDA.

For example, if the user specifies a 30 cm bin size, bin 1 velocity will be measured and averaged at a distance starting at 20 cm through 50 cm vertically from the head of the unit (blank after transmit plus bin 1 size). Likewise, bin 2 velocity would be measured and averaged at distance starting at 50 cm through

80 cm vertically from the transducer faces, and so on. The averaged velocities are then taken to be the velocity of the flow at the center of the bin. It is important to note that while the averaged velocity can be taken to be a point vertically outward from the ADCP, the velocity measurements are actually taken at 4 different locations within the beams which are emitted outward at 20 degree angles. This is very different from the methods used by the LDA system which takes data at a specific point in space. While most of the complexities of the operation of the ADCP are beyond the scope of this report, a more detailed explanation can be found in Reference 2.

Three bin sizes were investigated during this series of experiments, including 20 cm, 30 cm, and 40 cm. Due to mechanisms not fully understood, many bins returned bad data near the vertical center of the water tunnel. While it cannot be proven at this time, it is hypothesized that this may have been caused by acoustic reflections within the closed environment of the water tunnel. In order to simplify analysis, a single bin for each bin size was chosen to compare to the data obtained from the LDA system. Table 1 below shows the bin numbers selected to compare to LDA data and their respective locations vertically from the head of the ADCP.

Table 1: Bins and bin locations selected to compare to LDA data

Bin Size (cm)	Bin #	Start of Bin (cm)	End of Bin (cm)	Center of Bin (cm)
20	4	80	100	90
30	3	80	110	85
40	2	60	100	80

Since the ADCP determines the speed of the particles in the water by measuring the phase shift of the reflected acoustic waves returning to the unit, there is an ambiguity associated with these measurements. Specifically, the ambiguity refers to the fact that a phase shift of 90 degrees is indistinguishable from a phase shift of 450 degrees (360 degrees plus 90 degrees). In order to resolve this ambiguity, the user must specify a suitable ambiguity velocity based on the expected

water velocities. Ideally, the ambiguity velocity, also known as WV, is determined for an orientation with beam 3 into the flow by the equation:

$$WV = (\text{Max. Expected Velocity cm/s}) * \sin(\text{beam angle}) * 1.2 \quad (\text{Reference 2})$$

For beam 3 rotated 45 degrees from the direction of the flow, the equation for WV becomes:

$$WV = (\text{Max. Expected Velocity cm/s}) * \sin(\text{beam angle}) * 0.85 \quad (\text{Reference 2})$$

The maximum ambiguity velocity that can be input into the ADCP is 700 cm/s. By substituting the maximum ambiguity velocity into the two equations above, it can be determined that the maximum theoretical flow velocity that can be measured is 33 knots for beam 3 oriented into the flow, and 47 knots for beam 3 rotated 45 degrees from the direction of the flow.

Typically during sea trials the ADCP is mounted with beam 3 rotated 45 degrees to starboard. During this series of experiments data was collected with beam 3 oriented into the flow and with beam 3 rotated 45 degrees to starboard. The purpose of these variations was to determine the effect, if any, this orientation change has on the accuracy of the total velocity measurements. For this same reason, experiments were also conducted with the leading edge of the ADCP pitched approximately 10 degrees down relative to the flow and beam 3 rotated 45 degrees to starboard. See Appendix A for a complete listing of experiments conducted during this series.

Two water profiling modes were also tested during this series of experiments. Mode 1 is standard, which calculates velocity for each beam based on one ping per velocity calculation. Experiments were also collected using mode 12 which emits many sub-pings and averages the phase shift in the complex plane before calculating a velocity. Details about different modes can be found in Reference 3.

LDA data were acquired in order to compare to the data collected from the ADCPs. The LDA is a highly accurate system that can be used to obtain tunnel velocity data at specific points inside the LCC. The LDA accomplishes this by shooting laser beams through windows from outside the test section. Due to the

limited number and location of windows along the tunnel, LDA measurements could only be taken in approximately the same area as the ADCP. Several measurements were taken in the axial direction along a distance of 2.9 feet in order to determine the tunnel velocity gradient in this direction. Also, as shown in Figure 2, LDA measurements were taken in the vertical direction at distances of -1.0 to +2.0 feet from the centerline (a region from 3.0 feet to 6.0 feet vertically from the ADCP) in order to determine the tunnel velocity gradient in the vertical direction. The results of these experiments can be found in Appendix B.

A series of experiments was conducted to document the performance of the LCC during which extensive LDA data was taken. The results of those experiments are summarized below (Reference 4);

“The long term velocity stability of the LCC as measured by LDA at a single point for run times exceeding two hours is $\pm 0.15\%$ at the 95% confidence level for test section velocities from 0.5 to 18 m/s. The axial velocity variation in a rectangular cross-section over 17% of the test section cross-sectional area was measured as $\pm 0.34\%$ to $\pm 0.60\%$ at the 95% confidence level for velocities from 0.5 to 18 m/s.”

These results indicate the slight discrepancies between the LDA measurement location and the location of ADCP measurements are not significant. These statements were confirmed by LDA data collected during this series of experiments and are discussed later. Overall, the total uncertainty associated with LDA measurements is less than ± 0.05 knots (Reference 4). More details on the operation of the LDA system and the LCC can be found in Reference 4.

PRESENTATION AND DISCUSSION OF RESULTS

Data are presented for three different configurations of the 20 degree work-horse monitor ADCP. Results for the 20 degree ADCP with beam 3 oriented forward for several bin sizes are presented in Table 2. Several conclusions can be made from observing the results presented in this table. First, the standard deviation of the ADCP throughout the speed range tested tends to decrease with increasing bin size. Large bin sizes also seem to produce more accurate speed

data. By computing the average absolute value of the difference between the ADCP measured speed and the LDA measured speed, it can be seen that data for 30 cm bin sizes agreed better with the LDA data than 20 cm bin sizes (0.06 knot and 0.12 knot average differences, respectively). Likewise, the data for 40 cm bin sizes agreed better with the LDA than 30 cm bin sizes (0.04 knots and 0.06 knots, respectively) although only limited data was taken with 40 cm bin sizes. The flow in the LCC in the regions where measurements were made is highly uniform and does not vary with time. The conclusion that larger bin sizes produce more accurate velocity data is only valid for similar flows.

Results for the ADCP with beam 3 oriented 45 degrees to starboard for two bin sizes are presented in Table 3. The conclusions made in the previous paragraph regarding the relationship between bin size and velocity accuracy are reinforced by the results shown in Table 3. Unfortunately, no data was collected for this configuration with 40 cm bin sizes. However, the data collected for 30 cm bin sizes agreed closer to the LDA than the data collected for 20 cm bin sizes (0.06 knots and 0.09 knots respectively) although both sets of data agree well with LDA. The standard deviation of the data collected with the 30 cm bin sizes is also lower (0.45 knots compared to 0.72 knots).

When the data in Table 3 are compared to the data in Table 2 to examine the effect of the rotational orientation of the ADCP relative to the flow direction, it becomes apparent that the orientation has little effect on the accuracy of the data. For example, for 30 cm bin sizes, the average of the absolute value of the difference between the ADCP velocity and LDA velocity was exactly the same (0.06 knots). For 20 cm bin sizes, this value was only 0.03 knots lower when the unit was rotated 45 degrees to starboard.

Results for the ADCP with beam 3 oriented 45 degrees to starboard and the leading edge of the unit pitched 10 degrees down are presented in Table 4. For this orientation of the ADCP, bin size was not changed and set to 30 cm. Instead, the effect of using mode 12 was investigated and compare to results collected with mode 1. Recall that mode 12 uses a higher ping rate and thus should

decrease scatter in the data. The results in Table 4 support this hypothesis by showing that the standard deviation of the data collected by the ADCP was cut in half by using mode twelve (0.42 knots for mode 1 and 0.20 knots for mode 12). However, the averaged data collected using mode 1 actually agreed slightly better with the data collected with the LDA than the data collected using mode 12 (0.08 knot average difference with mode 1 and 0.12 knot average difference with mode 12). This slightly better agreement with mode 1 is small enough (0.04 knots) to recommend the use of mode 12 due to the improved standard deviation of the data.

The mode 1 data in Table 4 can be compared to the 30 cm bin size data in Table 3 to determine the effect pitching the ADCP has on the accuracy and scatter of the data. This reveals that the pitching of the unit had little to no effect on the data. The average of the absolute value of the difference between the ADCP and LDA was nominally the same for the pitched and unpitched experiments (0.08 knots and 0.06 knots, respectively). The same conclusion can be made about the standard deviation of the data (0.42 knots and 0.45 knots, respectively).

Table 5 shows a comparison of three ambiguity velocity settings for the 20 degree ADCP oriented with beam 3 rotated 45 degrees to starboard. Ambiguity velocities lower than 300 cm/s did not produce good data for any tunnel speed. The 300 cm/s setting only produced good data up to 20 knots. Comparing the results of the three ambiguity velocities tested reveals only slight differences in accuracy of the velocity data. The standard deviation for the 300 cm/s is slightly better than the other two, but not significant enough to make it preferable over the other two. Comparing the results with the ambiguity velocity set to 700 cm/s to 500 cm/s reveal similar results.

Based on the equation for WV discussed earlier, the theoretical maximum speed limit for the ADCP oriented with beam 3 rotated 45 degrees to starboard and ambiguity velocity set to 500 cm/s is nominally 33 knots. If the ambiguity velocity is set to 700 cm/s, the maximum speed limit is raised to 47 knots. Due to

the increased velocity limit gained by using the 700 cm/s ambiguity velocity, 700 cm/s is the recommended setting for all speeds during sea trials.

It should be noted that unsuccessful attempts were made to collect data at tunnel speeds in excess of the 32.5 knots shown in Table 5. It is believed that the bad data at speeds higher than 32.5 knots was caused by flow noise generated at the inception of cavitation. This could not be confirmed by raising the tunnel pressure due to the fact that the LCC is only able to obtain a centerline pressure of 45 psi at speeds higher than 30 knots.

Table 2: Experiment results for 20 degree ADCP with beam 3 forward for several bin sizes.

LDA Velocity (knots)	20 cm Bin Size			30 cm Bin Size			40 cm Bin Size		
	Bin #4 Velocity Average (knots)	Abs Value Difference ADCP-LDA (knots)	Bin #4 Velocity STDEV (knots)	Bin #3 Velocity Average (knots)	Abs Value Difference ADCP-LDA (knots)	Bin #3 Velocity STDEV (knots)	Bin #2 Velocity Average (knots)	Abs Value Difference ADCP-LDA (knots)	Bin #2 Velocity STDEV (knots)
1.05	1.36	0.31	0.62	1.14	0.09	0.43	1.07	0.02	0.34
5.12	5.08	0.04	0.75	5.04	0.08	0.46	5.07	0.05	0.31
9.99	9.96	0.03	0.73	10.00	0.01	0.47	N/A	N/A	N/A
15.08	15.20	0.12	0.70	15.09	0.01	0.42	15.03	0.05	0.39
20.37	20.33	0.04	0.69	N/A	N/A	N/A	N/A	N/A	N/A
24.99	24.78	0.21	0.71	N/A	N/A	N/A	N/A	N/A	N/A
30.04	29.97	0.07	0.76	29.95	0.09	0.49	N/A	N/A	N/A
35.10	N/A	N/A	N/A	35.03	0.07	0.58	N/A	N/A	N/A
Average: 0.03	Average: 0.12	Average: 0.71	Average: 0.06	Average: 0.48	Average: 0.04	Average: 0.34	Average: 0.04	Average: 0.04	Average: 0.34

*Note: All results shown in this table were conducted with ambiguity velocity = 700 cm/s and water mode = 1

Table 3: Experiment results of 20 degree ADCP with beam 3 oriented 45 degrees to starboard for two bin sizes.

LDA Velocity (knots)	LDA STDEV (knots)	20 cm Bin Size			30 cm Bin Size		
		Bin #4 Velocity Average (knots)	Abs Value Difference ADCP-LDA (knots)	Bin #4 Velocity STDEV (knots)	Bin #3 Velocity Average (knots)	Abs Value Difference ADCP-LDA (knots)	Bin #3 Velocity STDEV (knots)
2.12	0.00	2.23	0.11	0.73	2.11	0.01	0.41
5.12	0.01	5.15	0.03	0.74	5.06	0.06	0.43
10.01	0.02	9.84	0.17	0.70	9.96	0.05	0.43
15.10	0.03	15.14	0.04	0.70	15.17	0.07	0.43
20.31	0.03	20.46	0.15	0.66	20.43	0.12	0.45
25.06	0.04	25.07	0.01	0.73	25.18	0.12	0.45
30.11	0.05	30.08	0.03	0.73	30.12	0.01	0.48
32.65	0.06	32.51	0.14	0.79	32.62	0.03	0.51
Average: 0.03	Average: 0.09	Average: 0.72	Average: 0.06	Average: 0.45	Average: 0.06	Average: 0.45	Average: 0.45

*Note: All results shown in this table were conducted with ambiguity velocity=700cm/s and water mode=1

Table 4: Experiment results for 20 degree ADCP with beam 3 oriented 45 degrees to starboard and pitched 10 degrees.

			Water Mode 1			Water Mode 12		
LDA Velocity (knots)	LDA STDEV (knots)	Bin #3 Velocity Average (knots)	Abs Value Difference ADCP-LDA (knots)	Bin #3 Velocity STDEV (knots)	Bin #3 Velocity Average (knots)	Abs Value Difference ADCP-LDA (knots)	Bin #3 Velocity STDEV (knots)	Bin #3 Velocity Average (knots)
2.12	0.00	2.12	0.00	0.44	1.97	0.15	0.21	0.21
5.11	0.00	5.05	0.06	0.41	5.00	0.11	0.18	0.18
10.01	0.01	10.06	0.06	0.33	10.02	0.02	0.18	0.18
15.09	0.01	15.20	0.11	0.37	15.17	0.08	0.21	0.21
20.30	0.04	20.35	0.05	0.47	20.56	0.26	0.21	0.21
25.04	0.04	25.13	0.09	0.46	25.09	0.05	0.19	0.19
30.08	0.00	30.27	0.19	0.49	30.25	0.17	0.22	0.22
Average:	0.02	Average:	0.08	0.42	Average:	0.12	0.20	0.20

*Note: All results shown in this table were conducted with ambiguity velocity=700cm/s and bin size=30cm

Table 5: Experiment results for 20 degree ADCP with beam 3 oriented 45 degrees to starboard for several ambiguity velocities.

			700 cm/s Ambiguity Velocity			500 cm/s Ambiguity Velocity			300 cm/s Ambiguity Velocity		
LDA Velocity (knots)	LDA STDEV (knots)	Bin #3 Velocity Average (knots)	Abs Value Difference ADCP-LDA (knots)	Bin #3 Velocity STDEV (knots)	Bin #3 Velocity Average (knots)	Abs Value Difference ADCP-LDA (knots)	Bin #3 Velocity STDEV (knots)	Bin #3 Velocity Average (knots)	Abs Value Difference ADCP-LDA (knots)	Bin #3 Velocity STDEV (knots)	Bin #3 Velocity Average (knots)
2.12	0.00	2.11	0.01	0.41	2.13	0.01	0.40	2.09	0.03	0.36	0.36
5.12	0.01	5.06	0.06	0.43	5.00	0.12	0.39	5.11	0.01	0.32	0.32
10.01	0.02	9.96	0.05	0.43	10.02	0.01	0.40	10.10	0.09	0.33	0.33
15.10	0.03	15.17	0.07	0.43	15.17	0.07	0.38	15.13	0.03	0.35	0.35
20.31	0.03	20.43	0.12	0.45	20.38	0.07	0.42	20.42	0.11	0.34	0.34
25.06	0.04	25.18	0.12	0.45	25.09	0.03	0.47	Bad Data	N/A	N/A	N/A
30.11	0.05	30.12	0.01	0.48	30.17	0.06	0.46	Bad Data	N/A	N/A	N/A
32.65	0.06	32.62	0.03	0.51	32.76	0.11	0.45	Bad Data	N/A	N/A	N/A
Average:	0.03	Average:	0.07	0.45	Average:	0.07	0.42	Average:	0.06	0.33	0.33

*Note: All results shown in this table were conducted with bin size=30cm and water mode=1.

CONCLUSIONS

During this series of experiments, an ADCP was tested over a large range of water speeds and compared to results obtained from the LDA, a highly accurate speed source. The results of these experiments indicate the ADCP agreed very well to data collected by LDA over the entire speed range. It is recommended that for future sea trials where an ADCP is used to obtain ship speed, that the following settings be used:

1. Water mode set to 12
2. Ambiguity velocity (WV) set to 700 cm/s
3. Bin size set to suit the needs of the experiment or trial

The experimental results show that when these settings are used, the uncertainty of the water speed is nominally ± 0.2 knots throughout the speed range as shown in Table 4 for water mode 12.

ACKNOWLEDGMENTS

The author acknowledges the contributions and assistance of the following support team personnel: test engineer Ed Seifert; RDI representative Dr. Blair Brumley; LDA engineer Dr. James Cutbirth, technician William Burroughs; and LCC Operators.

APPENDIX A - EXPERIMENTAL AGENDA

This page left intentionally blank.

Table A-1: As tested experimental agenda for ADCP testing in the LCC.

NSWCCD Experimental Agenda

Acoustic Doppler Current Profiler (ADCP) Speed Calibration Experiments in the LCC
12 July - 16 July 2004 (12 hour shifts)

Experiment Nos. 1 -220
Test Engineers: Dylan Chirichella and Edward Seifert

Exp No.	Date	Unit / Comments	Rotation Relative to Beam 3 Fwd (deg)	Pitch Angle (degrees)	Tunnel Speed (knots)	Ambiguity Vel. (knots)	Bin Size (cm)	ADCP File Name	LDA File Name
	7/12	Rig for Experiments							
	7/13 - 7/14	Experiments							
1	6/13	20 degree Workhorse Sentinel	0	0	2.0	175	20	noseeds20v175b	vel02-0713
2	6/13	20 degree Workhorse Sentinel	0	0	20.0	500	20	k20s20v500	vel20-0713
3	6/13	20 degree Workhorse Sentinel	0	0	20.1	700	20	k20s20v700	vel20-0713
4	6/13	20 degree Workhorse Sentinel	0	0	24.7	700	20	k25s20v700	vel25-0713
5	6/13	20 degree Workhorse Sentinel	0	0	24.7	500	20	k25s20v500	vel25-0713
6	6/13	20 degree Workhorse Sentinel	0	0	24.7	300	20	k25s20v300	vel25-0713
7	6/13	20 degree Workhorse Sentinel	0	0	24.8	500	40	k25s40v500	vel25-0713
8	6/13	20 degree Workhorse Sentinel	0	0	29.8	700	20	k30s20v700	vel30-0713
9	6/13	20 degree Workhorse Sentinel	0	0	29.8	500	20	k30s20v500	vel30-0713
10	6/13	20 degree Workhorse Sentinel	0	0	29.8	700	30	k30s30v700	vel30-0713
11	6/13	20 degree Workhorse Sentinel	0	0	29.8	500	30	k30s30v500	vel30-0713
12	6/13	20 degree Workhorse Sentinel	0	0	34.8	700	20	k35s20v700	vel35-0713
13	6/13	20 degree Workhorse Sentinel	0	0	34.8	700	30	k35s30v700	vel35-0713
14	6/13	20 degree Workhorse Sentinel	0	0	34.8	500	30	k35s30v500	vel35-0713
15	6/13	20 degree Workhorse Sentinel	0	0	34.8	500	20	k35s20v500	vel35-0713
16	6/13	20 degree Workhorse Sentinel	0	0	34.8	350	20	k35s20v350	vel35-0713
17	6/13	20 degree Workhorse Sentinel	0	0	36.1	700	20	k36s20v700	vel37-0713
18	6/13	20 degree Workhorse Sentinel	0	0	36.1	700	30	k36s30v700	vel37-0713
19	6/13	20 degree Workhorse Sentinel	0	0	36.1	700	40	k36s40v700	vel37-0713
20	6/13	20 degree Workhorse Sentinel	0	0	36.1	500	20	k36s20v500	vel37-0713
21	6/13	20 degree Workhorse Sentinel	0	0	36.1	500	30	k36s30v500	vel37-0713
22	6/13	20 degree Workhorse Sentinel	0	0	36.1	500	40	k36s40v500	vel37-0713
23	6/13	20 degree Workhorse Sentinel	0	0	4.4	700	20	k5s20v700	vel05-0713
24	6/13	20 degree Workhorse Sentinel	0	0	4.4	700	30	k5s30v700	vel05-0713
25	6/13	20 degree Workhorse Sentinel	0	0	4.4	700	40	k5s40v700	vel05-0713
26	6/13	20 degree Workhorse Sentinel	0	0	4.4	500	20	k5s20v500	vel05-0713
27	6/13	20 degree Workhorse Sentinel	0	0	4.4	175	20	k5s20v175	vel05-0713
28	6/13	20 degree Workhorse Sentinel	0	0	4.4	100	20	k5s20v100	vel05-0713
29	6/13	20 degree Workhorse Sentinel	0	0	4.4	100	30	k5s30v100	vel05-0713
30	6/13	20 degree Workhorse Sentinel	0	0	9.5	700	20	k10s20v700	vel10-0713
31	6/13	20 degree Workhorse Sentinel	0	0	9.5	175	20	k10s20v175	vel10-0713
32	6/13	20 degree Workhorse Sentinel	0	0	9.5	500	20	k10s20v500	vel10-0713
33	6/13	20 degree Workhorse Sentinel	0	0	9.5	500	30	k10s30v500	vel10-0713
34	6/13	20 degree Workhorse Sentinel	0	0	9.5	700	30	k10s30v700	vel10-0713
35	6/13	20 degree Workhorse Sentinel	0	0	14.8	700	20	k15s20v700	vel15-0713
36	6/13	20 degree Workhorse Sentinel	0	0	14.8	700	30	k15s30v700	vel15-0713
37	6/13	20 degree Workhorse Sentinel	0	0	14.8	700	40	k15s40v700	vel15-0713
38	6/13	20 degree Workhorse Sentinel	0	0	14.8	500	20	k15s20v500	vel15-0713
39	6/13	20 degree Workhorse Sentinel	0	0	14.8	500	30	k15s30v500	vel15-0713
40	6/13	20 degree Workhorse Sentinel	0	0	14.8	300	30	k15s30v300	vel15-0713
41	6/13	20 degree Workhorse Sentinel	0	0	14.8	300	20	k15s20v300	vel15-0713
42	6/13	20 degree Workhorse Sentinel	0	0	14.8	175	30	k15s30v175	vel15-0713
43	6/13	20 degree Workhorse Sentinel	0	0	14.8	700	20	k15s20v700b	vel15-0713
44	6/13	20 degree Workhorse Sentinel	0	0	1.0	700	20	k1s20v700	vel01-0713
45	6/13	20 degree Workhorse Sentinel	0	0	1.0	175	20	k1s20v175	vel01-0713
46	6/13	20 degree Workhorse Sentinel	0	0	1.0	500	20	k1s20v500	vel01-0713
47	6/13	20 degree Workhorse Sentinel	0	0	1.0	300	20	k1s20v300	vel01-0713
48	6/13	20 degree Workhorse Sentinel	0	0	1.0	300	30	k1s30v300	vel01-0713
49	6/13	20 degree Workhorse Sentinel	0	0	1.0	700	30	k1s30v700	vel01-0713
50	6/13	20 degree Workhorse Sentinel	0	0	1.0	175	30	k1s30v175	vel01-0713
51	6/13	20 degree Workhorse Sentinel	0	0	1.0	500	30	k1s30v500	vel01-0713
52	6/13	20 degree Workhorse Sentinel	0	0	1.0	175	40	k1s40v175	vel01-0713
53	6/13	20 degree Workhorse Sentinel	0	0	1.0	700	40	k1s40v700	vel01-0713
54	6/13	20 degree Workhorse Sentinel	0	0	1.0	100	20	k1s20v100	vel01-0713
		Beam 3 Oriented 45 deg to STBD							
55	6/13	20 degree Workhorse Sentinel	45 to STBD	0	24.8	700	20	45k25s20v700	vel25-0713-2
56	6/13	20 degree Workhorse Sentinel	45 to STBD	0	24.8	700	30	45k25s30v700	vel25-0713-2
57	6/13	20 degree Workhorse Sentinel	45 to STBD	0	24.8	500	30	45k25s30v500	vel25-0713-2
58	6/13	20 degree Workhorse Sentinel	45 to STBD	0	24.8	300	30	45k25s30v300	vel25-0713-2
59	6/13	20 degree Workhorse Sentinel	45 to STBD	0	24.8	175	30	45k25s30v175	vel25-0713-2
60	6/13	20 degree Workhorse Sentinel	45 to STBD	0	24.8	175	20	45k25s20v175	vel25-0713-2
61	6/13	20 degree Workhorse Sentinel	45 to STBD	0	24.8	500	20	45k25s20v500	vel25-0713-2
62	6/13	20 degree Workhorse Sentinel	45 to STBD	0	24.8	300	20	45k25s20v300	vel25-0713-2
63	6/13	20 degree Workhorse Sentinel	45 to STBD	0	24.8	100	20	45k25s20v100	vel25-0713-2
64	6/13	20 degree Workhorse Sentinel	45 to STBD	0	29.8	700	20	45k30s20v700	vel30-0713-2
65	6/13	20 degree Workhorse Sentinel	45 to STBD	0	29.8	700	30	45k30s30v700	vel30-0713-2
66	6/13	20 degree Workhorse Sentinel	45 to STBD	0	29.8	300	30	45k30s30v300	vel30-0713-2

Table A-1 (Continued): As tested experimental agenda for ADCP testing in the LCC

Exp No.	Date	Unit / Comments	Rotation Relative to Beam 3 Fwd (deg)	Pitch Angle (degrees)	Tunnel Speed (knots)	Ambiguity Vel. (knots)	Bin Size (cm)	ADCP File Name	LDA File Name
67	6/13	20 degree Workhorse Sentinel	45 to STBD	0	29.8	500	30	45k30s30v500	vel30-0713-2
68	6/13	20 degree Workhorse Sentinel	45 to STBD	0	29.8	175	30	45k30s30v175	vel30-0713-2
69	6/13	20 degree Workhorse Sentinel	45 to STBD	0	29.8	175	20	45k30s20v175	vel30-0713-2
70	6/13	20 degree Workhorse Sentinel	45 to STBD	0	29.8	500	20	45k30s20v500	vel30-0713-2
71	6/13	20 degree Workhorse Sentinel	45 to STBD	0	29.8	300	20	45k30s20v300	vel30-0713-2
72	6/13	20 degree Workhorse Sentinel	45 to STBD	0	29.8	100	20	45k30s20v100	vel30-0713-2
73	6/13	20 degree Workhorse Sentinel	45 to STBD	0	34.8	700	20	45k35s20v700	vel35-0713-2
74	6/13	20 degree Workhorse Sentinel	45 to STBD	0	34.8	700	30	45k35s30v700	vel35-0713-2
75	6/13	20 degree Workhorse Sentinel	45 to STBD	0	34.8	300	30	45k35s30v300	vel35-0713-2
76	6/13	20 degree Workhorse Sentinel	45 to STBD	0	34.8	175	30	45k35s30v175	vel35-0713-2
77	6/13	20 degree Workhorse Sentinel	45 to STBD	0	34.8	175	20	45k35s20v175	vel35-0713-2
78	6/13	20 degree Workhorse Sentinel	45 to STBD	0	34.8	500	20	45k35s20v500	vel35-0713-2
79	6/13	20 degree Workhorse Sentinel	45 to STBD	0	34.8	300	20	45k35s20v300	vel35-0713-2
80	6/13	20 degree Workhorse Sentinel	45 to STBD	0	34.8	500	30	45k35s20v300	vel35-0713-2
81	6/13	20 degree Workhorse Sentinel	45 to STBD	0	34.8	100	20	45k35s20v100	vel35-0713-2
82	6/13	20 degree Workhorse Sentinel	45 to STBD	0	34.8	700	20	45k35s20v700p45	none
83	6/13	20 degree Workhorse Sentinel	45 to STBD	0	34.8	700	30	45k35s30v700p45	none
84	6/13	20 degree Workhorse Sentinel	45 to STBD	0	34.8	300	30	45k35s30v300p45	none
85	6/13	20 degree Workhorse Sentinel	45 to STBD	0	34.8	500	30	45k35s30v500p45	none
86	6/13	20 degree Workhorse Sentinel	45 to STBD	0	34.8	175	30	45k35s30v175p45	none
87	6/13	20 degree Workhorse Sentinel	45 to STBD	0	34.8	175	20	45k35s20v175p45	none
88	6/13	20 degree Workhorse Sentinel	45 to STBD	0	32.3	700	20	45k32_5s20v700p40	vel32-0713
89	6/13	20 degree Workhorse Sentinel	45 to STBD	0	32.3	700	30	45k32_5s30v700	vel32-0713
90	6/13	20 degree Workhorse Sentinel	45 to STBD	0	32.3	300	30	45k32_5s30v300	vel32-0713
91	6/13	20 degree Workhorse Sentinel	45 to STBD	0	32.3	500	30	45k32_5s30v500	vel32-0713
92	6/13	20 degree Workhorse Sentinel	45 to STBD	0	32.3	175	30	45k32_5s30v175	vel32-0713
93	6/13	20 degree Workhorse Sentinel	45 to STBD	0	32.3	175	20	45k32_5s20v175	vel32-0713
94	6/13	20 degree Workhorse Sentinel	45 to STBD	0	32.3	500	20	45k32_5s20v500	vel32-0713
95	6/13	20 degree Workhorse Sentinel	45 to STBD	0	32.3	100	20	45k32_5s20v100	vel32-0713
96	6/13	20 degree Workhorse Sentinel	45 to STBD	0	32.3	300	20	45k32_5s20v300	vel32-0713
97	6/13	20 degree Workhorse Sentinel	45 to STBD	0	20.0	700	20	45k20s20v700	vel20-0713
98	6/13	20 degree Workhorse Sentinel	45 to STBD	0	20.0	700	30	45k20s30v700	vel20-0713
99	6/13	20 degree Workhorse Sentinel	45 to STBD	0	20.0	300	30	45k20s30v300	vel20-0713
100	6/13	20 degree Workhorse Sentinel	45 to STBD	0	20.0	500	30	45k20s30v500	vel20-0713
101	6/13	20 degree Workhorse Sentinel	45 to STBD	0	20.0	175	30	45k20s30v175	vel20-0713
102	6/13	20 degree Workhorse Sentinel	45 to STBD	0	20.0	175	20	45k20s20v175	vel20-0713
103	6/13	20 degree Workhorse Sentinel	45 to STBD	0	20.0	500	20	45k20s20v500	vel20-0713
104	6/13	20 degree Workhorse Sentinel	45 to STBD	0	20.0	300	20	45k20s20v300	vel20-0713
105	6/13	20 degree Workhorse Sentinel	45 to STBD	0	20.0	100	20	45k20s20v100	vel20-0713
106	6/13	20 degree Workhorse Sentinel	45 to STBD	0	14.8	700	20	45k15s20v700	vel15-0713
107	6/13	20 degree Workhorse Sentinel	45 to STBD	0	14.8	300	30	45k15s30v300	vel15-0713
108	6/13	20 degree Workhorse Sentinel	45 to STBD	0	14.8	500	30	45k15s30v500	vel15-0713
109	6/13	20 degree Workhorse Sentinel	45 to STBD	0	14.8	175	30	45k15s30v175	vel15-0713
110	6/13	20 degree Workhorse Sentinel	45 to STBD	0	14.8	175	20	45k15s20v175	vel15-0713
111	6/13	20 degree Workhorse Sentinel	45 to STBD	0	14.8	500	20	45k15s20v500	vel15-0713
112	6/13	20 degree Workhorse Sentinel	45 to STBD	0	14.8	300	20	45k15s20v300	vel15-0713
113	6/13	20 degree Workhorse Sentinel	45 to STBD	0	14.8	100	20	45k15s20v100	vel15-0713
114	6/13	20 degree Workhorse Sentinel	45 to STBD	0	9.6	700	20	45k10s20v700	vel10-0713
115	6/13	20 degree Workhorse Sentinel	45 to STBD	0	9.6	700	30	45k10s30v700	vel10-0713
116	6/13	20 degree Workhorse Sentinel	45 to STBD	0	9.6	300	30	45k10s30v300	vel10-0713
117	6/13	20 degree Workhorse Sentinel	45 to STBD	0	9.6	700	30	45k10s30v700	vel10-0713
118	6/13	20 degree Workhorse Sentinel	45 to STBD	0	9.6	500	30	45k10s30v500	vel10-0713
119	6/13	20 degree Workhorse Sentinel	45 to STBD	0	9.6	175	30	45k10s30v175	vel10-0713
120	6/13	20 degree Workhorse Sentinel	45 to STBD	0	9.6	175	20	45k10s20v175	vel10-0713
121	6/13	20 degree Workhorse Sentinel	45 to STBD	0	9.6	500	20	45k10s20v500	vel10-0713
122	6/13	20 degree Workhorse Sentinel	45 to STBD	0	9.6	300	20	45k10s20v300	vel10-0713
123	6/13	20 degree Workhorse Sentinel	45 to STBD	0	9.6	100	20	45k10s20v100	vel10-0713
124	6/13	20 degree Workhorse Sentinel	45 to STBD	0	9.6	100	30	45k10s30v100	vel10-0713
125	6/13	20 degree Workhorse Sentinel	45 to STBD	0	4.3	700	20	45k5s20v700	vel5-0713
126	6/13	20 degree Workhorse Sentinel	45 to STBD	0	4.3	700	30	45k5s30v700	vel5-0713
127	6/13	20 degree Workhorse Sentinel	45 to STBD	0	4.3	300	30	45k5s30v300	vel5-0713
128	6/13	20 degree Workhorse Sentinel	45 to STBD	0	4.3	500	30	45k5s30v500	vel5-0713
129	6/13	20 degree Workhorse Sentinel	45 to STBD	0	4.3	175	30	45k5s30v175	vel5-0713
130	6/13	20 degree Workhorse Sentinel	45 to STBD	0	4.3	175	20	45k5s20v175	vel5-0713
131	6/13	20 degree Workhorse Sentinel	45 to STBD	0	4.3	500	20	45k5s20v500	vel5-0713
132	6/13	20 degree Workhorse Sentinel	45 to STBD	0	4.3	300	20	45k5s20v300	vel5-0713
133	6/13	20 degree Workhorse Sentinel	45 to STBD	0	4.3	100	20	45k5s20v100	vel5-0713
134	6/13	20 degree Workhorse Sentinel	45 to STBD	0	4.3	100	30	45k5s30v100	vel5-0713
135	6/13	20 degree Workhorse Sentinel	45 to STBD	0	2.0	700	20	45k2s20v700	vel2-0713
136	6/13	20 degree Workhorse Sentinel	45 to STBD	0	2.0	700	30	45k5s30v700	vel2-0713
137	6/13	20 degree Workhorse Sentinel	45 to STBD	0	2.0	300	30	45k5s30v300	vel2-0713
138	6/13	20 degree Workhorse Sentinel	45 to STBD	0	2.0	500	30	45k5s30v500	vel2-0713
139	6/13	20 degree Workhorse Sentinel	45 to STBD	0	2.0	175	30	45k5s30v175	vel2-0713
140	6/13	20 degree Workhorse Sentinel	45 to STBD	0	2.0	175	20	45k5s20v175	vel2-0713
141	6/13	20 degree Workhorse Sentinel	45 to STBD	0	2.0	500	20	45k5s20v500	vel2-0713
142	6/13	20 degree Workhorse Sentinel	45 to STBD	0	2.0	300	20	45k5s20v300	vel2-0713
143	6/13	20 degree Workhorse Sentinel	45 to STBD	0	2.0	100	20	45k5s20v100	vel2-0713
144	6/13	20 degree Workhorse Sentinel	45 to STBD	0	2.0	100	30	45k5s30v100	vel2-0713

Table A-1 (Continued): As tested experimental agenda for ADCP testing in the LCC

Exp No.	Date	Unit / Comments	Rotation Relative to Beam 3 Fwd (deg)	Pitch Angle (degrees)	Tunnel Speed (knots)	Ambiguity Vel. (knots)	Bin Size (cm)	ADCP File Name	LDA File Name
		Unit is pitched 10 degrees							
145	6/14	20 degree Workhorse Sentinel	45 to STBD	10 down	20.0	700	30	45t10k20m12v700	vel20-0714-3
146	6/14	20 degree Workhorse Sentinel	45 to STBD	10 down	20.0	700	30	45t10k20m12v700Ship	vel20-0714-3
147	6/14	20 degree Workhorse Sentinel	45 to STBD	10 down	20.0	700	30	45t10k20m1v700	vel20-0714-3
148	6/14	20 degree Workhorse Sentinel	45 to STBD	10 down	20.0	700	30	45t10k20m1v700b	vel20-0714-3
149	6/14	20 degree Workhorse Sentinel	45 to STBD	10 down	20.0	500	30	45t10k20m1v500	vel20-0714-3
150	6/14	20 degree Workhorse Sentinel	45 to STBD	10 down	24.8	700	30	45t10k25m12v700	vel25-0714-3
151	6/14	20 degree Workhorse Sentinel	45 to STBD	10 down	24.8	700	30	45t10k25m12v700Ship	vel25-0714-3
152	6/14	20 degree Workhorse Sentinel	45 to STBD	10 down	24.8	700	30	45t10k25m1v700	vel25-0714-3
153	6/14	20 degree Workhorse Sentinel	45 to STBD	10 down	24.8	700	30	45t10k25m1v500	vel25-0714-3
154	6/14	20 degree Workhorse Sentinel	45 to STBD	10 down	29.8	700	30	45t10k30m12v700	vel30-0714-3
155	6/14	20 degree Workhorse Sentinel	45 to STBD	10 down	29.8	700	30	45t10k30m12v700Ship	vel30-0714-3
156	6/14	20 degree Workhorse Sentinel	45 to STBD	10 down	29.8	700	30	45t10k30m1v700	vel30-0714-3
157	6/14	20 degree Workhorse Sentinel	45 to STBD	10 down	29.8	500	30	45t10k30m1v500	vel30-0714-3
158	6/14	20 degree Workhorse Sentinel	45 to STBD	10 down	29.8	700	30	45t10k30m12v700p45	vel30-0714-3
159	6/14	20 degree Workhorse Sentinel	45 to STBD	10 down	29.8	700	30	45t10k30m12v700p45ship	vel30-0714-3
160	6/14	20 degree Workhorse Sentinel	45 to STBD	10 down	29.8	700	30	45t10k30m1v700p45	vel30-0714-3
161	6/14	20 degree Workhorse Sentinel	45 to STBD	10 down	29.8	500	30	45t10k30m1v500p45	vel30-0714-3
162	6/14	20 degree Workhorse Sentinel	45 to STBD	10 down	35.0	700	30	45t10k35m12v700p45	vel35-0714-3
163	6/14	20 degree Workhorse Sentinel	45 to STBD	10 down	35.0	700	30	45t10k35m12v700p45ship	vel35-0714-3
164	6/14	20 degree Workhorse Sentinel	45 to STBD	10 down	35.0	700	30	45t10k35m1v700p45	vel35-0714-3
165	6/14	20 degree Workhorse Sentinel	45 to STBD	10 down	35.0	500	30	45t10k35m1v500p45	vel35-0714-3
166	6/14	20 degree Workhorse Sentinel	45 to STBD	10 down	35.0	700	30	45t10k35m12v700	vel35-0714-3
167	6/14	20 degree Workhorse Sentinel	45 to STBD	10 down	35.0	700	30	45t10k35m12v700ship	vel35-0714-3
168	6/14	20 degree Workhorse Sentinel	45 to STBD	10 down	35.0	700	30	45t10k35m1v700	vel35-0714-3
169	6/14	20 degree Workhorse Sentinel	45 to STBD	10 down	35.0	500	30	45t10k35m1v500	vel35-0714-3
170	6/14	20 degree Workhorse Sentinel	45 to STBD	10 down	2.0	700	30	45t10k2m12v700	vel2-0714-3
171	6/14	20 degree Workhorse Sentinel	45 to STBD	10 down	2.0	700	30	45t10k2m12v700ship	vel2-0714-3
172	6/14	20 degree Workhorse Sentinel	45 to STBD	10 down	2.0	700	30	45t10k2m1v700	vel2-0714-3
173	6/14	20 degree Workhorse Sentinel	45 to STBD	10 down	2.0	500	30	45t10k2m1v500	vel2-0714-3
174	6/14	20 degree Workhorse Sentinel	45 to STBD	10 down	2.0	175	30	45t10k2m1v175	vel2-0714-3
175	6/14	20 degree Workhorse Sentinel	45 to STBD	10 down	2.0	175	20	45t10k2m1s20v175	vel2-0714-3
176	6/14	20 degree Workhorse Sentinel	45 to STBD	10 down	2.0	100	20	45t10k2m1s20v100	vel2-0714-3
177	6/14	20 degree Workhorse Sentinel	45 to STBD	10 down	5.0	700	30	45t10k5m12v700	vel5-0714-3
178	6/14	20 degree Workhorse Sentinel	45 to STBD	10 down	5.0	175	30	45t10k5m12v175	vel5-0714-3
179	6/14	20 degree Workhorse Sentinel	45 to STBD	10 down	5.0	700	30	45t10k5m12v700ship	vel5-0714-3
180	6/14	20 degree Workhorse Sentinel	45 to STBD	10 down	5.0	175	30	45t10k5m12v175ship	vel5-0714-3
181	6/14	20 degree Workhorse Sentinel	45 to STBD	10 down	5.0	700	30	45t10k5m1v700	vel5-0714-3
182	6/14	20 degree Workhorse Sentinel	45 to STBD	10 down	5.0	500	30	45t10k5m1v500	vel5-0714-3
183	6/14	20 degree Workhorse Sentinel	45 to STBD	10 down	5.0	175	30	45t10k5m1v175	vel5-0714-3
184	6/14	20 degree Workhorse Sentinel	45 to STBD	10 down	10.0	700	30	45t10k10m12v700	vel10-0714-3
185	6/14	20 degree Workhorse Sentinel	45 to STBD	10 down	10.0	175	30	45t10k10m12v175	vel10-0714-3
186	6/14	20 degree Workhorse Sentinel	45 to STBD	10 down	10.0	700	30	45t10k10m12v700ship	vel10-0714-3
187	6/14	20 degree Workhorse Sentinel	45 to STBD	10 down	10.0	300	30	45t10k10m12v300ship	vel10-0714-3
188	6/14	20 degree Workhorse Sentinel	45 to STBD	10 down	10.0	700	30	45t10k10m1v700	vel10-0714-3
189	6/14	20 degree Workhorse Sentinel	45 to STBD	10 down	10.0	300	30	45t10k10m1v300	vel10-0714-3
190	6/14	20 degree Workhorse Sentinel	45 to STBD	10 down	15.0	700	30	45t10k15m12v700	vel15-0714-3
191	6/14	20 degree Workhorse Sentinel	45 to STBD	10 down	15.0	350	30	45t10k15m12v350	vel15-0714-3
192	6/14	20 degree Workhorse Sentinel	45 to STBD	10 down	15.0	700	30	45t10k15m12v700ship	vel15-0714-3
193	6/14	20 degree Workhorse Sentinel	45 to STBD	10 down	15.0	350	30	45t10k15m12v350ship	vel15-0714-3
194	6/14	20 degree Workhorse Sentinel	45 to STBD	10 down	15.0	700	30	45t10k15m1v700	vel15-0714-3
195	6/14	20 degree Workhorse Sentinel	45 to STBD	10 down	15.0	350	30	45t10k15m1v350	vel15-0714-3
	6/14	Change to 30 deg WH Navigator Firmware Version 16.23c!							
196	6/14	30 degree Workhorse Navigator	45 to STBD	0	30.0	700	30	navk30v700p45Ship	vel30-0714-4
197	6/14	30 degree Workhorse Navigator	45 to STBD	0	30.0	700	30	navk30v700p45	vel30-0714-4
198	6/14	30 degree Workhorse Navigator	45 to STBD	0	30.0	700	30	navk30m12v700p45Shipb	vel30-0714-4
199	6/14	30 degree Workhorse Navigator	45 to STBD	0	30.0	700	30	navk30m12v700p45Shipptp25b	vel30-0714-4
		Change to Water Mode 12							
200	6/14	30 degree Workhorse Navigator	45 to STBD	0	30.0	700	30	navk30m12v700p45	vel30-0714-4
201	6/14	30 degree Workhorse Navigator	45 to STBD	0	30.0	700	30	navk30m12v700p45Ship	vel30-0714-4
202	6/14	30 degree Workhorse Navigator	45 to STBD	0	30.0	700	30	navk30m12v700p45Shipwo5_10	vel30-0714-4
203	6/14	30 degree Workhorse Navigator	45 to STBD	0	30.0	700	30	navk30m12v700p45Ship	vel30-0714-4
204	6/14	30 degree Workhorse Navigator	45 to STBD	0	30.0	700	30	navk30m12v700p45Shipwo7_10	vel30-0714-4
205	6/14	30 degree Workhorse Navigator	45 to STBD	0	35.0	700	30	navk35v700p45Ship	vel35-0714-4
206	6/14	30 degree Workhorse Navigator	45 to STBD	0	35.0	700	30	navk35v700p45	vel35-0714-4
207	6/14	30 degree Workhorse Navigator	45 to STBD	0	35.0	700	30	navk35m12v700p45Shipwo7_10	vel35-0714-4
208	6/14	30 degree Workhorse Navigator	45 to STBD	0	35.0	700	30	navk35m12v700p45wo7_10	vel35-0714-4
209	6/14	30 degree Workhorse Navigator	45 to STBD	0	15.0	300	30	navk15v300ship	vel15-0714-4
210	6/14	30 degree Workhorse Navigator	45 to STBD	0	15.0	300	30	navk15v300	vel15-0714-4
211	6/14	30 degree Workhorse Navigator	45 to STBD	0	15.0	300	30	navk15m12v300wo7_10	vel15-0714-4
212	6/14	30 degree Workhorse Navigator	45 to STBD	0	15.0	300	30	navk15m12v300shipwo7_10	vel15-0714-4
213	6/14	30 degree Workhorse Navigator	45 to STBD	0	5.0	175	30	navk5v175	vel5-0714-4
214	6/14	30 degree Workhorse Navigator	45 to STBD	0	5.0	175	30	navk5v175ship	vel5-0714-4
215	6/14	30 degree Workhorse Navigator	45 to STBD	0	5.0	175	30	navk5m12v175wo7_10	vel5-0714-4
216	6/14	30 degree Workhorse Navigator	45 to STBD	0	5.0	175	30	navk5m12v175shipwo7_10	vel5-0714-4
217	6/14	30 degree Workhorse Navigator	45 to STBD	0	2.0	175	30	navk2v175	vel2-0714-4
218	6/14	30 degree Workhorse Navigator	45 to STBD	0	2.0	175	30	navk2v175ship	vel2-0714-4
219	6/14	30 degree Workhorse Navigator	45 to STBD	0	2.0	175	30	navk2m12v175wo7_10	vel2-0714-4
220	6/14	30 degree Workhorse Navigator	45 to STBD	0	2.0	175	30	navk2m12v175shipwo7_10	vel2-0714-4

This page left intentionally blank.

APPENDIX B - LDA DATA

This page left intentionally blank.

To insure small differences in flow measurement location with respect to the LDA and ADCP, LDA measurements were made at several locations in order to determine axial and vertical velocity gradients in the LCC. Four separate series of LDA data were taken during these experiments. Table B-1 below shows how the LDA data sets correspond to the ADCP experimental configurations for the first three data sets. The fourth set was conducted with the 30 degree ADCP and is not shown here.

Table B-1: LDA data set inventory.

LDA Data Set #	ADCP Unit	ADCP Orientation
1	20 degree Monitor	Beam 3 Forward
2	20 degree Monitor	Beam 3 rotated 45 degrees to starboard
3	20 degree Monitor	Beam 3 rotated 45 degrees to starboard and pitched 10 degrees

Data from LDA set 1 are shown below in Figure B-1, Figure B-2, and Figure B-3. Data from set 2 and 3 is nearly identical to set 1, therefore only data from set 1 is presented in this report. Complete LDA data is available upon request of Code 5200.

Figure B-1 shows the LDA velocity measurements at several different axial locations along the centerline of the LCC. The slope of the linear black line is taken to be the axial gradient of velocity in the tunnel. This plot shows that the axial gradient of velocity in the tunnel is very small. Over an axial distance of over one meter, U_x/U_{avg} changed by approximately 0.3%. The ADCP was approximately 1 to 2 feet downstream of the LDA measurements. From the data shown in Figure B-1 it is reasonable to assume this difference in axial location had little to no effect on the data.

Figure B-2 and Figure B-3 show how the velocity as measured by the LDA is affected by vertical location. The vertical location was varied at two different axial locations, 50 mm and 895 mm from the LDA starting location. The slope of the linear black line in each plot is taken to be the vertical gradient of velocity in the tunnel at the respective axial location. At the 50 mm axial location, the gradient is approximately 0.6% of U_{avg} over a vertical distance of 1 meter. At the 895

mm axial location, the gradient is approximately 0.3% of U_{avg} over a vertical distance of 1 meter. The position of the average LDA measurements used to compare to the ADCP data differed in vertical location from the center of the ADCP bins used to calculate velocity by approximately 0.5 m. From the data shown in Figure B-2 and Figure B-3 it is reasonable to assume this difference in vertical location had little to no effect on the data.

Axial Tunnel Velocities at Several Axial Positions

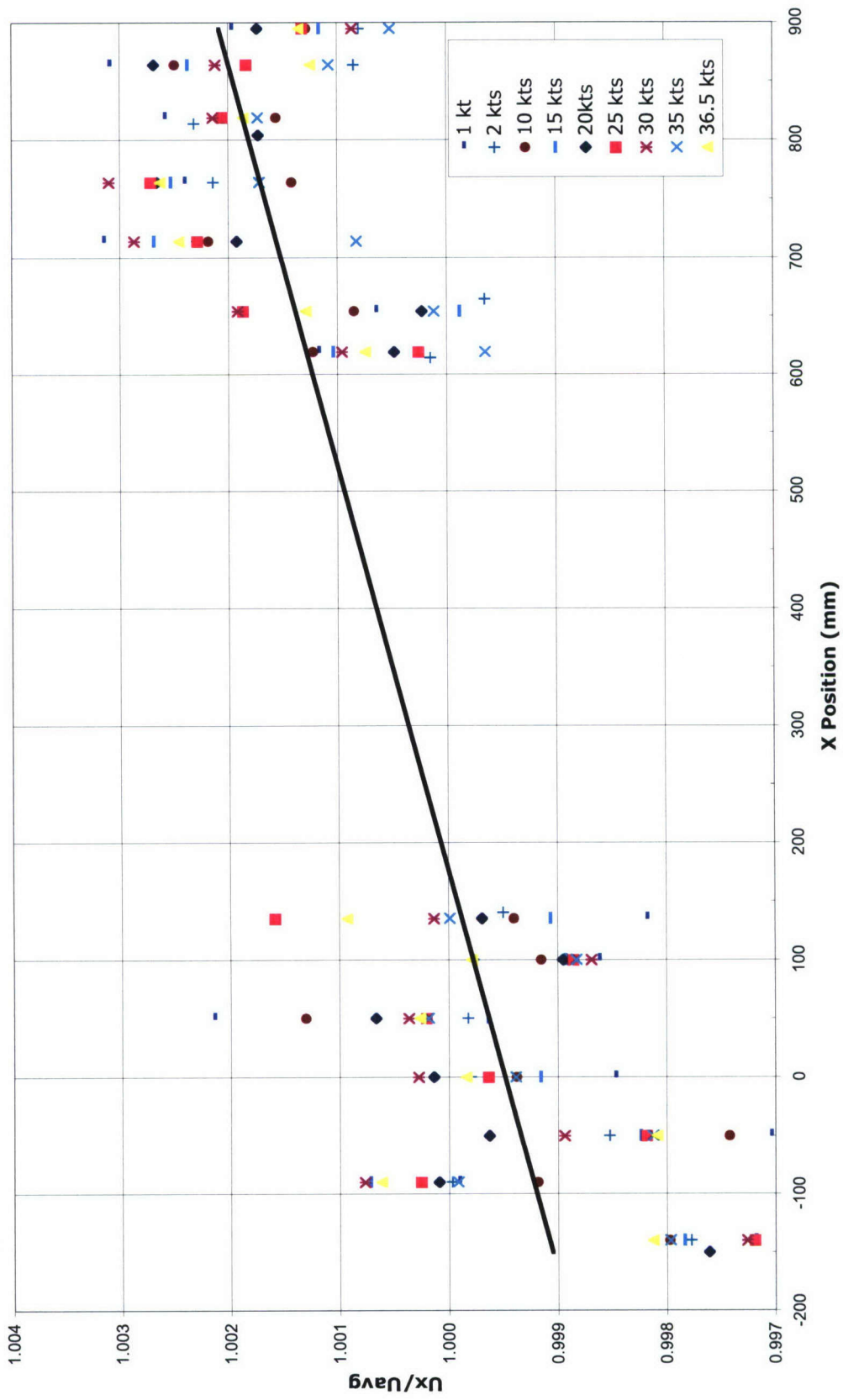

Figure B-1: Axial tunnel velocities at several axial positions as measured by LDA along the centerline of the LCC.

Axial Tunnel Velocities at Several Vertical Locations - 50mm Axial Position

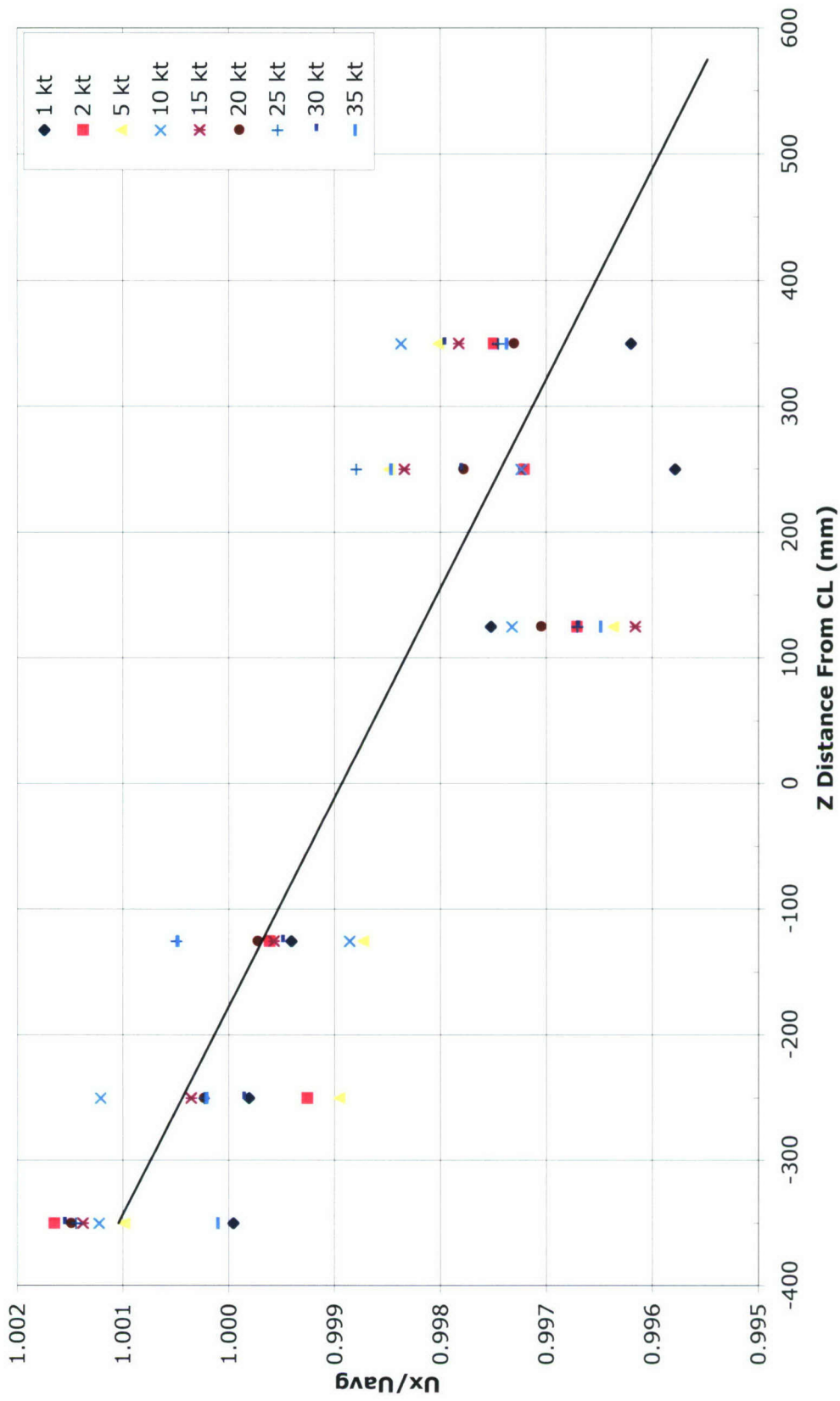

Figure B-2: Axial tunnel velocities at several vertical locations as measured by LDA at a 50 mm axial location.

Axial Tunnel Velocities at Several Vertical Locations - 895mm Axial Position

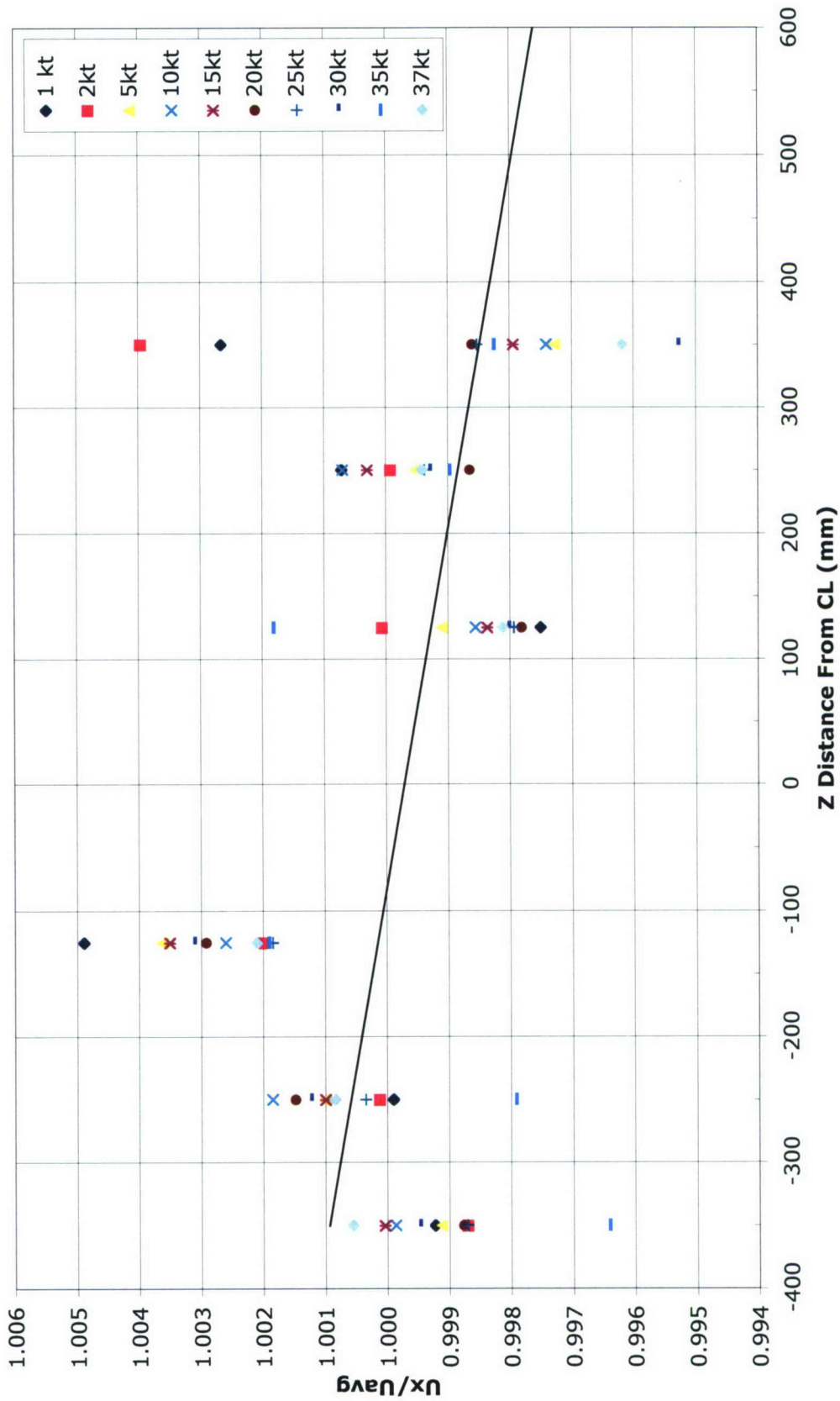

Figure B-3: Axial tunnel velocities at several vertical locations as measured by LDA at a 895 mm axial location.

This page left intentionally blank.

REFERENCES

1. Noblesse, F., et al., "Global Uncertainty Analysis of Full-scale Submarine Propulsion Predictions Using Model Tests in the LCC", Carderock Division Naval Surface Warfare Center Hydromechanics Directorate Research and Development Report NSWCCD-TR-1998-020, November 1998.
2. "Acoustic Doppler Current Profiler Principles of Operation: A Practical Primer", Second Edition for Broadband ADCPs, RD Instruments; San Diego, California, 1996.
3. "Workhorse Commands and Output Data Format", RD Instruments; San Diego, California, August 2002.
4. Park, J.T., et al., "Hydrodynamic Performance of the Large Cavitation Channel (LCC)", Carderock Division Naval Surface Warfare Center Hydromechanics Directorate Technical Report NSWCCD-50-TR-2002/068, December 2002.

This page left intentionally blank.

DISTRIBUTION LIST

Serial	Code	Name(s)
NAVSEA DISTRIBUTION		
1	05Z1	King
2	PMS 450T	Riley
3	DTIC	
NSWCCD DISTRIBUTION		
4	3452	Library (PDF only)
	5010	Administrative Office (w/o enclosure)
5	5060	Walden
6-10	5600	Ammeen, Chirichella, Seifert, File (2)