

**FINAL REPORT
JULY 2007**

REPORT NO. 06-04D



**EVALUATION TRANSPORTABILITY TESTING OF THE JOINT
MODULAR INTERMODAL PLATFORM (JMIP) UNIT #4
TP-94-01,
“TRANSPORTABILITY TESTING PROCEDURES”**

Prepared for:

Distribution Unlimited:

TACOM/ ARDEC
Logistics Research and Engineering Directorate
ATTN: AMSRD-AAR-AIL-F
Picatinny Arsenal, NJ 07806



**DEFENSE AMMUNITION CENTER
VALIDATION ENGINEERING DIVISION
MCALESTER, OKLAHOMA 74501-9053**

20071226018

AVAILABILTY NOTICE

A copy of this report will be furnished each attendee on automatic distribution. Additional copies or authority for reprinting may be obtained by written request from:

Director
U.S. Army Defense Ammunition Center
ATTN: SJMAC-DEV
1 C Tree Road, Bldg. 35
McAlester, OK 74501-9053

DISTRIBUTION INSTRUCTIONS

Destroy this report when no longer needed. Do not return.

Citation of trade names in this report does not constitute an official endorsement.

The information contained herein will not be used for advertising purposes.

**EVALUATION TRANSPORTABILITY TESTING OF THE
JOINT MODULAR INTERMODAL PLATFORM (JMIP) UNIT #4
TP-94-01, REV. 2, JUNE 2004, "TRANSPORTABILITY TESTING
PROCEDURES"**

ABSTRACT

The U.S. Army Defense Ammunition Center (DAC), Validation Engineering Division (SJMAG-DEV), was tasked by the Logistics Research and Engineering Directorate (AMSRD-AAR-AIL-F), Picatinny Arsenal, NJ to conduct evaluation transportability testing on the Joint Modular Intermodal Platform (JMIP) Unit #4 manufactured by SEA BOX Inc, East Riverton, NJ. The testing was conducted in accordance with TP-94-01, Revision 2, June 2004 "Transportability Testing Procedures." The test load consisted of a single layer of Joint Modular Intermodal Containers (JMICs) secured to the JMIP.

The objective of the testing was to identify the adequacy of the JMIP for demonstration use and not final approval when transportability tested in accordance with TP-94-01, Revision 2, June 2004.

The following observations resulted from the testing of JMIP #4:

1. Prior to the start of testing the hydraulic connections at the rear of the JMIP were leaking.
2. The DIN locks on the empty JMIP would bind on the DIN locks on the Palletized Load System (PLS) truck when the platform was unloaded.
3. The rails at the front of JMIP did not rest on the PLS truck supports (frog feet) and the holes in the JMIP rail did not align with the rail transport pin hole on the PLS truck.
4. The JMIP slid side-to-side throughout the Shipboard Transportation Simulator (STS) testing. The movement of the adjustment bolt on the

cams did occur during the testing. Future designs of the cam locking devices should prevent the bolts from moving in and out.

5. Final inspection revealed that the frame above the JMIP rollers was bent. The deformation probably occurred when the rollers contacted the container door sill when the JMIP was loaded into the intermodal container.
6. The lock rings on the roller shafts disengaged during testing and were found on the container floor.
7. The container corner posts at the closed end were damaged due to contact with the hard blocks on the JMIP.
8. Final inspection following the removal of the JMIPs revealed that the spring steel JMIP lock covers were damaged.
9. The locks on some of the JMIPs were difficult to unlock upon completion of the testing. The use of a pry bar was sometimes required to disengage the locks.

The JMIP, as tested, **is adequate**, to be used to transport the Navy JMIP containers with ammunition **when not in an intermodal container**. The JMIP, as tested, **is not adequate**, to transport the Navy JMIPs, in an intermodal container due to the damage the hard plastic JMIP end blocks caused to the intermodal container.

The hard plastic end blocks were replaced with a softer rubber end bumpers for follow-on testing (06-04F, 06-04G, 06-04H, 06-04J). The intermodal container corner posts were not damaged during testing when the softer rubber end bumpers were used. Therefore, the JMIP with the soft rubber end bumpers is adequate to be used in container transport.

The JMIP with the changes to the end blocks is adequate to transport ammunition for demonstration purposes. The operational condition of the JMIP should be closely monitored during the demonstrations. Also, the Defense

Ammunition Center, Transportation Engineering Division shall be consulted for the loading and bracing instructions.

Prepared by:

Reviewed by:

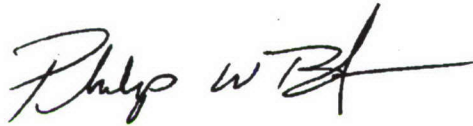

PHILIP W. BARICKMAN
Lead Validation Engineer

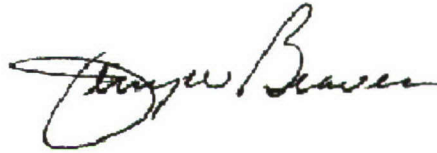

JERRY W. BEAVER
Chief, Validation Engineering Division

U.S. ARMY DEFENSE AMMUNITION CENTER

VALIDATION ENGINEERING DIVISION
MCALESTER, OK 74501-9053

REPORT NO. 06-04D

**Evaluation Transportability Testing of the Joint Modular Intermodal
Platform (JMIP) Unit #4
TP-94-01, Revision 2, June 2004 "Transportability Testing Procedures"**

TABLE OF CONTENTS

PART	PAGE NO.
1. INTRODUCTION	1-1
A. BACKGROUND	1-1
B. AUTHORITY	1-1
C. OBJECTIVE	1-1
D. OBSERVATIONS	1-1
E. CONCLUSION	1-2
2. ATTENDEES	2-1
3. TEST EQUIPMENT	3-1
4. TEST PROCEDURES	4-1
A. RAIL TEST	4-1
B. ON/OFF ROAD TESTS	4-3
1. HAZARD COURSE	4-3
2. ROAD TRIP	4-4
3. PANIC STOPS	4-4
4. WASHBOARD COURSE	4-4
C. OCEAN-GOING VESSEL TEST. Shipboard Transportation Simulator .	4-4
5. TEST RESULTS	5-1
5.1 TESTING DATE –17-18 April 2007	5-1
A. RAIL TEST	5-2
B. ON/OFF ROAD TESTS	5-3
1. HAZARD COURSE	5-3
2. ROAD TRIP	5-4
3. PANIC STOPS	5-4
4. HAZARD COURSE	5-4
5. WASHBOARD COURSE	5-5
C. SHIPBOARD TRANSPORTATION SIMULATOR (STS)	5-5
D. OBSERVATIONS	5-7
E. CONCLUSIONS	5-8

5.2 TESTING DATE –19 April 2007	5-9
A. ON/OFF ROAD TESTS	5-9
1. HAZARD COURSE	5-9
2. ROAD TRIP	5-10
3. PANIC STOPS	5-10
4. HAZARD COURSE	5-10
5. WASHBOARD COURSE.....	5-10
B. OBSERVATION	5-10
C. CONCLUSIONS	5-12
5.3 TESTING DATE –19 April 2007	5-13
A. ON/OFF ROAD TESTS	5-13
1. HAZARD COURSE	5-13
2. ROAD TRIP	5-14
3. PANIC STOPS	5-14
4. HAZARD COURSE	5-14
5. WASHBOARD COURSE.....	5-14
B. CONCLUSIONS.....	5-15
5.4 TESTING DATE –24 April 2007	5-17
A. RAIL TEST	5-17
B. CONCLUSION	5-19
6. DRAWINGS.....	6-1

PART 1 – INTRODUCTION

A. BACKGROUND. The U.S. Army Defense Ammunition Center (DAC), Validation Engineering Division (SJMACE-DEV), was tasked by the Logistics Research and Engineering Directorate (AMSRD-AAR-AIL-F), Picatinny Arsenal, NJ to conduct evaluation transportability testing on the Joint Modular Intermodal Platform (JMIP) Unit #4 manufactured by SEA BOX, Inc, East Riverton, NJ. The testing was conducted in accordance with TP-94-01, Revision 2, June 2004 “Transportability Testing Procedures.” The test load consisted of a single layer of Joint Modular Intermodal Containers (JMICEs) secured to the JMIP.

B. AUTHORITY. This test was conducted IAW mission responsibilities delegated by the U.S. Army Joint Munitions Command (JMC), Rock Island, IL. Reference is made to the following:

1. AR 740-1, 15 June 2001, Storage and Supply Activity Operation.
2. OSC-R, 10-23, Mission and Major Functions of U.S. Army Defense Ammunition Center (DAC) 21 Nov 2000.

C. OBJECTIVE. The objective of the testing was to identify the adequacy of the JMIP for demonstration use and not final approval when transportability tested in accordance with TP-94-01, Revision 2, June 2004.

D. OBSERVATIONS.

1. Prior to the start of testing the hydraulic connections at the rear of the JMIP were leaking.
2. The DIN locks on the empty JMIP would bind on the DIN locks on the Palletized Load System (PLS) truck when the platform was unloaded.

3. The rails at the front of JMIP #4 did not rest on the PLS truck supports (frog feet) and the holes in the JMIP rail did not align with the rail transport pin holes on the PLS truck.

4. The JMIP slid side-to-side throughout the Shipboard Transportation Simulator (STS) testing. The movement of the adjustment bolt on the cams occurred during the testing. Future designs of the cam locking devices should prevent the bolts from moving in and out.

5. Final inspection revealed that the frame above the JMIP rollers was bent. The deformation probably occurred when the rollers contacted the container door sill when the JMIP was loaded into the intermodal container.

6. The lock rings on the roller shafts disengaged during testing and were found on the container floor.

7. The container corner posts at the closed end were damaged due to contact with the hard blocks on the JMIP.

8. Final inspection following the removal of the JMICs revealed that the spring steel JMIC lock covers were damaged.

9. The locks on some of the JMICs were difficult to unlock upon completion of the testing. The use of a pry bar was sometimes required to disengage the locks.

E. CONCLUSION.

The JMIP as tested **is adequate** to be used to transport the Navy JMICs with ammunition **when not in an intermodal container**. The JMIP as tested, **is not adequate** to transport the Navy JMICs, **in an intermodal container** due to the damage the hard plastic JMIP end blocks caused to the intermodal container.

The hard plastic end blocks were replaced with a softer rubber end bumpers for follow-on testing (06-04F, 06-04G, 06-04H, 06-04J). No damage was done to the intermodal container corner posts when the softer rubber end bumpers were used. Therefore, the JMIP with the soft rubber end bumpers is adequate to be used in container transport.

The JMIP with the changes to the end block is adequate to transport ammunition for demonstration purposes. The operational condition of the JMIP should be closely monitored during the demonstrations. Also, the Defense Ammunition Center, Transportation Engineering Division shall be consulted for the loading and bracing instructions.

PART 2 - ATTENDEES

ATTENDEE

Philip Barickman
DSN 956-8992
(918) 420-8992

Michael S. Bartosiak
DSN 956-8083
(918) 420-8083

Joseph Cappetta
(973) 724-7197

Bob Cook
(973) 724-2115

MAILING ADDRESS

Director
U.S. Army Defense Ammunition Center
ATTN: SJMAC-DEV
1 C Tree Road, Bldg. 35
McAlester, OK 74501-9053

Director
U.S. Army Defense Ammunition Center
ATTN: SJMAC-DET
1 C Tree Road, Bldg. 35
McAlester, OK 74501-9053

U.S. Army Armament Research,
Development and Engineering Center
Logistics Research & Engineering Dir.
ATTN: AMSRD-AAR-AIL-F
Picatinny Arsenal, NJ 07806-5001

U.S. Army Armament Research,
Development and Engineering Center
Logistics Research & Engineering Dir.
ATTN: AMSRD-AAR-AIL-F
Picatinny Arsenal, NJ 07806-5001

PART 3 - TEST EQUIPMENT

1. Joint Modular Intermodal Platform Unit #4
Manufactured by: SEA BOX, Inc., East Riverton, NJ
Model Number: J-MIP
Serial Number: 00004
Date of Manufacture: 26 January 2007
Tare Weight: 4,240 lbs (without straps, rings and end gates)

2. Joint Modular Intermodal Container
Designed by Naval PHST Center - Earle, NJ
Length: 51-3/4 inches
Width: 43-3/4 inches
Height: 43 inches

3. Palletized Load System Truck
Model #: M1074
Manufactured by: Oshkosh Truck Corporation, Oshkosh, WI
ID #: 10T2P1NH6N1044011
NSN: 2320-01-304-2277
Serial #: 44011
Curb Weight: 55,000 lbs

4. Truck, Tractor, MTV, M1088 A1
ID #: J0229
NSN: 2320 01 447 3893
VSN: NL1FSC
MFG Serial #: T-018488EFJM
Weight: 19,340 lbs

5. Semitrailer, flatbed, breakbulk/container transporter, 34 ton
Model #: M872A1
Manufactured by: Heller Truck Body Corporation, Hillsdale, NJ
ID #: 11-1505 NX05NZ
NSN: 2330 01 109 8006
Weight: 19,240 lbs

8. Intermodal Container
ID # CMCU 200006-8
Date of Manufacture: 06/99
Manufactured by: Charleston Marine Containers, Charleston, SC
Tare Weight: 4,870 lbs
Maximum Gross Weight: 67,200 lbs

9. Railcar, DODX 42353
Manufactured by: Thrall Car
Length: 89 feet – 4 inches
Empty Weight: 85,000 lbs

PART 4 - TEST PROCEDURES

The test procedures outlined in this section were extracted from TP-94-01, "Transportability Testing Procedures," Revision 2, June 2004, for validating tactical vehicles and outloading procedures used for shipping munitions by tactical truck, railcar, and ocean-going vessel.

The rail impact will be conducted with the test load secured directly to the railcar. Inert (non-explosive) items were used to build the load. The test loads were prepared using the blocking and bracing procedures proposed for use with munitions (**see Part 6 – Drawings for procedures**). The weight and physical characteristics (weights, physical dimensions, center of gravity, etc.) of the test loads were similar to live (explosive) ammunition.

A. RAIL TEST. RAIL IMPACT TEST METHOD. The test load or vehicle will be secured to a flatcar. The equipment needed to perform the test will include the specimen (hammer) car, four empty railroad cars connected together to serve as the anvil, and a railroad locomotive. The anvil cars will be positioned on a level section of track with air and hand brakes set and with draft gears compressed. The locomotive unit will push the specimen car toward the anvil at a predetermined speed, then disconnect from the specimen car approximately 50 yards away from the anvil cars allowing the specimen car to roll freely along the track until it strikes the anvil. This will constitute an impact. Impacting will be accomplished at speeds of 4, 6, and 8.1 mph in one direction and at a speed of 8.1 mph in the reverse direction. The tolerance for the speeds is plus 0.5 mph, minus 0.5 mph for the 4 mph and 6 mph impacts, and plus 0.5 mph, minus 0 mph for the 8.1 mph impacts. The impact speeds will be determined by using an electronic counter to measure the time for the specimen car to traverse an 11-foot distance immediately prior to contact with the anvil cars (see Figure 1).

**ASSOCIATION OF AMERICAN RAILROADS (AAR)
STANDARD TEST PLAN**

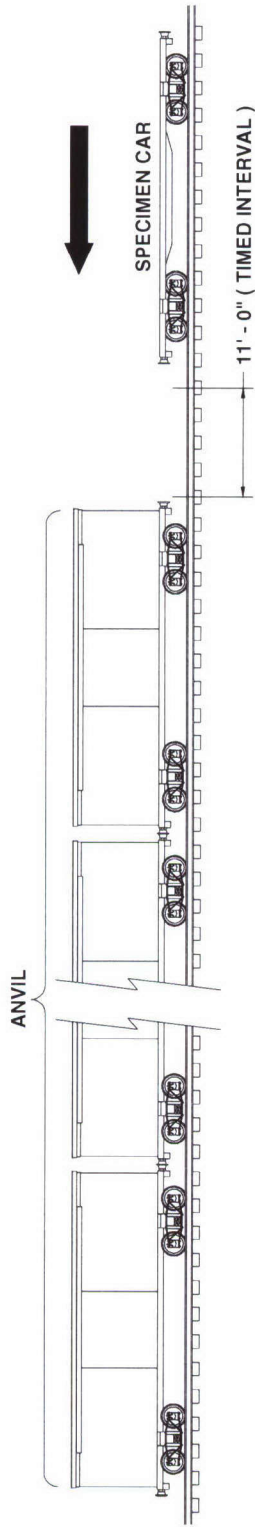

**4 BUFFER CARS (ANVIL)
WITH DRAFT GEAR
COMPRESSED AND AIR BRAKES IN A SET
POSITION**

ANVIL CAR TOTAL WT. 250,000 LBS (APPROX)

**SPECIMEN CAR IS RELEASED BY SWITCH ENGINE
TO**

ATTAIN: IMPACT NO. 1 @ 4 MPH

IMPACT NO. 2 @ 6 MPH

IMPACT NO. 3 @ 8.1 MPH

**THEN THE CAR IS REVERSED AND RELEASED BY
SWITCH ENGINE TO ATTAIN:**

IMPACT NO. 4 @ 8.1 MPH

Figure 1. Rail Impact Sketch

B. ON/OFF ROAD TEST.

1. **HAZARD COURSE.** The test load or vehicle will be transported over the 200-foot-long segment of concrete-paved road consisting of two series of railroad ties projecting 6 inches above the level of the road surface. The hazard course will be traversed two times (see Figure 2).

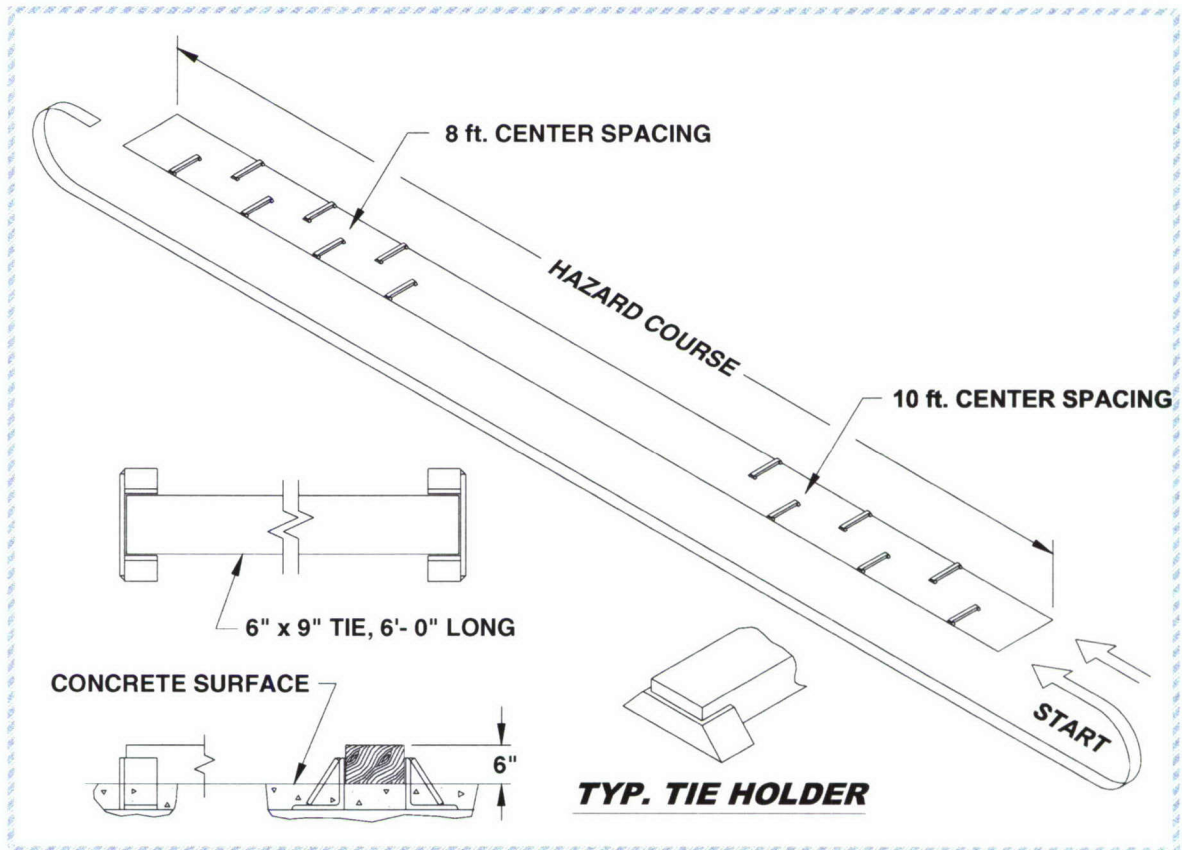

Figure 2. Hazard Course Sketch

- a. The first series of 6 ties are spaced on 10-foot centers and alternately positioned on opposite sides of the road centerline for a distance of 50 feet.
- b. Following the first series of ties, a paved roadway of 75 feet separates the first and second series of railroad ties.

c. The second series of 7 ties are spaced on 8-foot centers and alternately positioned on opposite sides of the road centerline for a distance of 48 feet.

d. The test load is driven across the hazard course at speeds that will produce the most violent vertical and side-to-side rolling reaction obtainable in traversing the hazard course (approximately 5 mph).

2. ROAD TRIP. The test load or vehicle will be transported for a distance of 30 miles over a combination of roads surfaced with gravel, concrete, and asphalt. The test route will include curves, corners, railroad crossings and stops and starts. The test load or vehicle will travel at the maximum speed for the particular road being traversed, except as limited by legal restrictions.

3. PANIC STOPS. During the road trip, the test load or vehicle will be subjected to three (3) full airbrake stops while traveling in the forward direction and one in the reverse direction while traveling down a 7 percent grade. The first three stops are at 5, 10, and 15 mph while the stop in the reverse direction is approximately 5 mph. This testing will not be required if the Rail Impact Test is performed.

4. WASHBOARD COURSE. The test load or vehicle will be driven over the washboard course at a speed that produces the most violent response in the vertical direction.

C. OCEAN-GOING VESSEL TEST. Shipboard Transportation Simulator (Test Method 5). The Shipboard Transportation Simulator (STS) is used for testing loads in 8-foot-wide by 20-foot-long intermodal freight containers. The specimen shall be positioned onto the STS and securely locked in place using the cam lock at each corner. Using the procedure detailed in the operating instructions, the STS shall begin oscillating at an angle of 30 degrees, plus or minus 2 degrees, either side of vertical center and a frequency of 2 cycles-per-

minute (30 seconds, plus or minus 2 seconds) for a duration of two (2) hours. This frequency shall be observed for apparent defects that could cause a safety hazard. The frequency of oscillation shall then be increased to 4 cycles-per-minute (15 seconds, plus or minus one second per cycle) and the apparatus operated for two (2) hours. If an inspection of the load does not indicate an impending failure, the frequency of oscillation shall be further increased to 5 cycles-per-minute (12 seconds, plus or minus one second per cycle), and the apparatus operated for four (4) hours. The operation does not necessarily have to be continuous; however, no changes or adjustments to the load or load restraints shall be permitted at any time during the test. After once being set in place, the test load (specimen) shall not be removed from the apparatus until the test has been completed or is terminated.

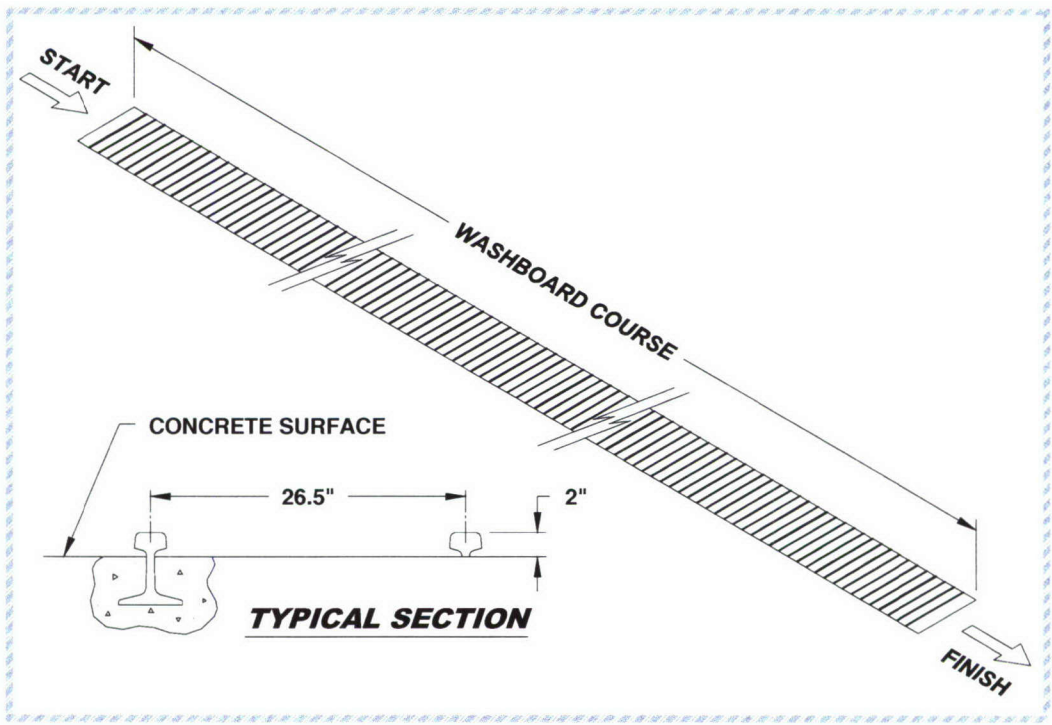

Figure 3. Washboard Course Sketch

PART 5 - TEST RESULTS

5.1

Test Specimen: SEABOX Joint Modular Intermodal Platform Unit #4
in an Intermodal Container

Payload: 8 Navy Joint Modular Intermodal Containers (JMIC).

Testing Date: 17-18 April 2007

Gross Weight: 26, 360 lbs (Including JMIP and JMICs).

Notes:

1. Prior to the start of testing, the hydraulic connections at the rear of the JMIP were leaking.

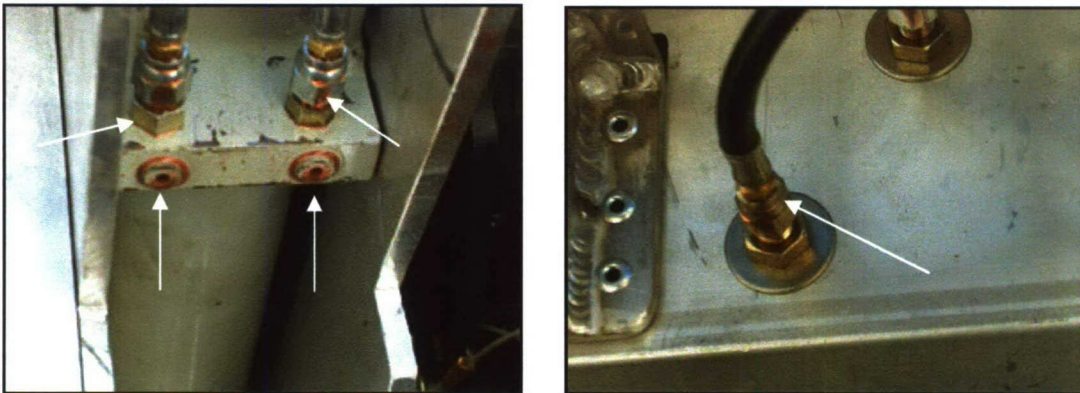

Photo 1. Hydraulic Leaks

2. The DIN locks on the empty JMIP would bind on the DIN locks on the PLS truck when the platform was unloaded.

A. RAIL TEST.



Photo 2. Rail Impact Testing of the JMIP (Prior to Testing)

Description	Weight
Flatcar Number: DODX 42353	85,000 lbs.
Intermodal Container with JMIP	31,230 lbs.
M1 Flatrack with MLRS Pods	28,265 lbs.
Total Specimen Wt.	144,495 lbs.
Buffer Car (four cars)	257,900 lbs.

Figure 4.

Remarks: Figure 4 lists the test components and weights of the items used during the Rail Impact Tests.

Impact Number	Avg. Velocity (mph)
1	3.7
2	6.0
3	7.7
4	8.3
5	8.5

Figure 5.

Remarks:

1. Figure 5 lists the average speeds of the specimen car immediately prior to impact with the anvil. Impact #5 is the reverse impact.
2. Impact #3 was determined to be a “no test” due to the insufficient velocity at impact. The test was repeated.
3. Following Impact #5 the JMIP moved 0.5 inches in the direction of impact and the JMICs moved 0.25 inches in the direction of impact.

B. ON/OFF ROAD TESTS.

1. HAZARD COURSE.



Photo 3. Hazard Course Testing of the JMIP

Pass No.	Elapsed Time	Avg. Velocity (mph)
1	25 Seconds	6
2	24 Seconds	6

Figure 6.

Remarks:

1. Figure 6 lists the average speeds of the test load through the Hazard Course.
2. Inspection did not reveal any damage to the JMIP.

2. ROAD TRIP:

Remarks:

1. The Road Trip was conducted between the Hazard Course Passes #2 and #3.
2. Inspection following the Road Trip revealed no damage or movement of the JMIP.

3. PANIC STOPS: Testing was not required since the load was rail impact tested.

4. HAZARD COURSE:

Pass No.	Elapsed Time	Avg. Velocity (mph)
3	25 Seconds	6
4	25 Seconds	6

Figure 7.

Remarks:

1. Figure 7 lists the average speeds of the test load through the Hazard Course.
2. Inspection did not reveal any damage to the JMIP.

5. WASHBOARD COURSE:

Remarks:

Inspection following the Washboard Course revealed no damage to the JMIP.



Photo 4. Washboard Course Testing of the JMIP

C. SHIPBOARD TRANSPORTATION SIMULATION (STS).

Remarks:

1. The JMIP slid side-to-side throughout the STS testing. The movement of the adjustment bolt on the cams occurred during the testing. Future designs of the cam locking devices should prevent the bolts from moving in and out.
2. Final inspection revealed that the frame above the JMIP rollers was bent. The deformation probably occurred when the rollers contacted the container door sill as the JMIP was loaded into the intermodal container.

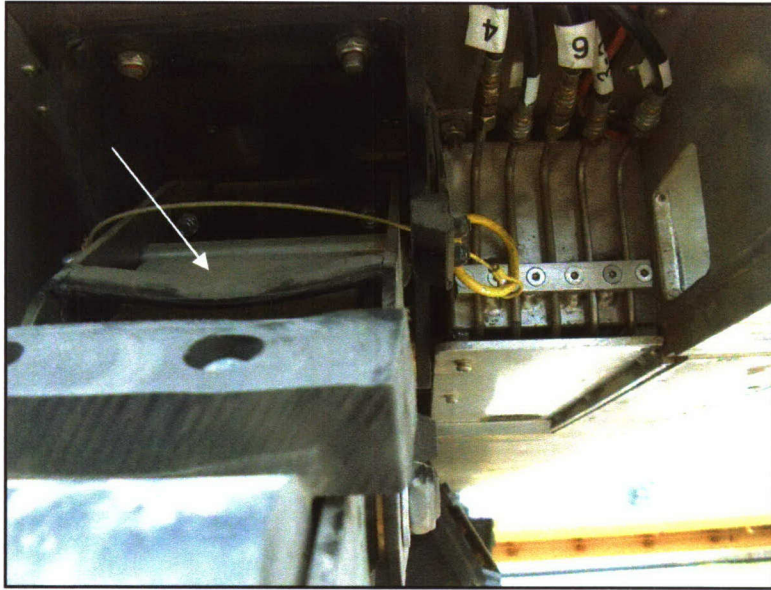

Photo 5. Damaged Roller Frame

3. The lock rings on the roller shafts disengaged during testing and were found on the container floor.

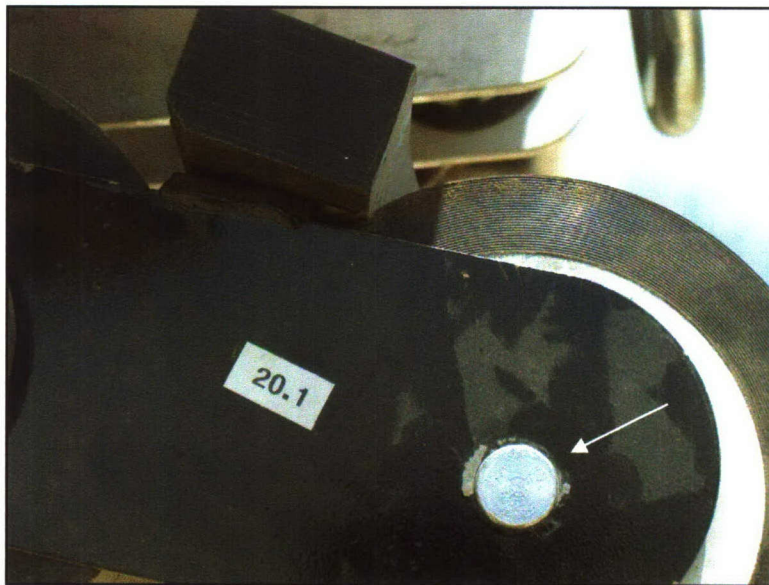

Photo 6. Missing Roller Lock Ring

4. The container corner posts at the closed end were damaged due to contact with the hard blocks on the JMIP.



Photo 7. Damaged Container Corner Post

D. OBSERVATIONS:

1. Final inspection following the removal of the JMICs revealed that the spring steel JMIC lock covers were damaged.

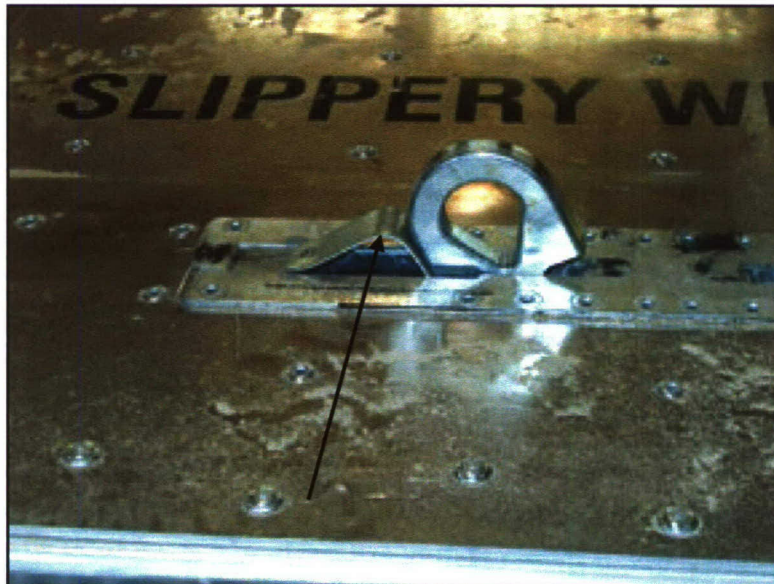

Photo 8. Damaged Spring Steel Covers

2. The locks on some of the JMICs were difficult to unlock upon completion of the testing. The use of a pry bar was sometimes required to disengage the locks.

E. CONCLUSIONS:

1. The JMIP, as currently designed, is **not adequate** to transport the Navy JMICs , in an intermodal container due to the damage the JMIP end blocks caused to the intermodal container.

2. The purpose of the testing was to identify the adequacy of the JMIP for demonstration use and not final approval. Testing has identified deficiencies with the current design.

3. The operational condition of the JMIP should be closely monitored during the demonstration. Also, the Defense Ammunition Center, Transportation Engineering Division, shall be consulted for the ammunition loading and bracing instructions.

Note: The hard plastic end blocks were replaced with a softer rubber end bumpers for follow on testing (06-04F, 06-04G, 06-04H, 06-04J). The intermodal container corner posts were not damaged during testing when the softer rubber end bumpers were used. Therefore, the JMIP with the soft rubber end bumpers, is adequate to be used in container transport.

5.2

Test Specimen: SEABOX Joint Modular Intermodal Platform Unit #4
on the PLS Truck

Payload: 8 Navy Joint Modular Intermodal Containers (JMIP).

Testing Date: 19 April 2007

Gross Weight: 26, 360 lbs (Including JMIP and JMIPs).

A. ON/OFF ROAD TESTS.

1. HAZARD COURSE.



Photo 9. Hazard Course Testing of the JMIP

Pass No.	Elapsed Time	Avg. Velocity (mph)
1	24 Seconds	6
2	24 Seconds	6

Figure 8.

Remarks:

1. Figure 8 lists the average speeds of the test load through the Hazard Course.
2. Inspection did not reveal any damage to the JMIP.

2. ROAD TRIP:

Remarks:

1. The Road Trip was conducted between the Hazard Course Passes #2 and #3.
2. Inspection following the Road Trip revealed no damage or movement of the JMIP.

3. PANIC STOPS: Testing was not required since the load was rail impact tested.

4. HAZARD COURSE:

Pass No.	Elapsed Time	Avg. Velocity (mph)
3	22 Seconds	6
4	20 Seconds	7

Figure 9.

Remarks:

1. Figure 9 lists the average speeds of the test load through the Hazard Course.
2. Inspection did not reveal any damage to the JMIP.

5. WASHBOARD COURSE:

Remarks: Inspection following the Washboard Course revealed no damage to the JMIP.

B. OBSERVATION: The rails at the front of JMIP #4 did not rest on the PLS truck supports (frog feet) and the holes in the JMIP rail did not align with the rail transport pin hole on the PLS truck.



Photo 10. JMIP Rails not on PLS Truck Supports

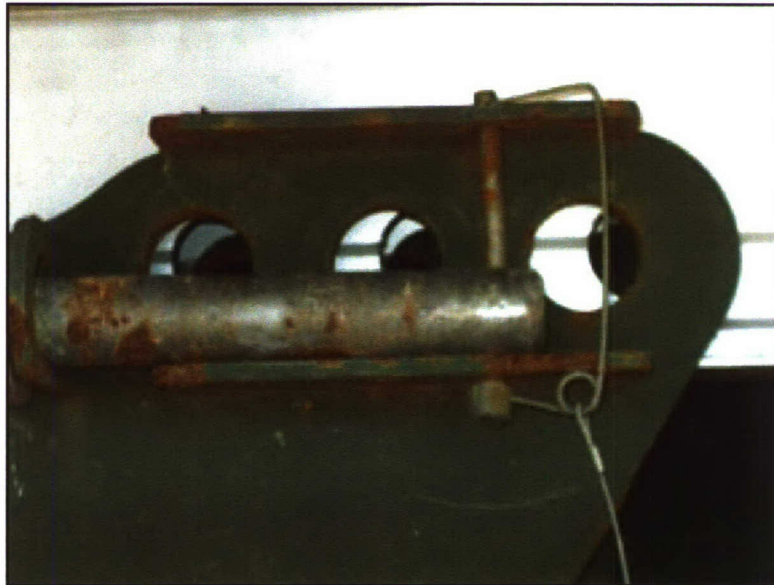

Photo 11. Misalignment of Rail Transport Pin Holes



Photo 12. Washboard Course Testing JMIP

C. CONCLUSIONS:

1. The JMIP, as currently designed, is adequate to be used to transport the Navy JMICs with ammunition on the PLS truck.
2. The purpose of the testing was to identify the adequacy of the JMIP for demonstration use and not final approval. Testing has identified deficiencies with the current design.
3. The operational condition of the JMIP should be closely monitored during the demonstration. Also, the Defense Ammunition Center, Transportation Engineering Division, shall be consulted for the ammunition loading and bracing instructions.

5.3

Test Specimen: SEABOX Joint Modular Intermodal Platform Unit #4

Secured to the M872 Trailer

Payload: 8 Navy Joint Modular Intermodal Containers (JMIP).

Testing Date: 19 April 2007

Gross Weight: 26,360 lbs (Including JMIP and JMIPs).

A. ON/OFF ROAD TESTS.

1. HAZARD COURSE.



Photo 13. Hazard Course Testing of the JMIP

Pass No.	Elapsed Time	Avg. Velocity (mph)
1	25 Seconds	6
2	24 Seconds	6

Figure 10.

Remarks:

1. Figure 10 lists the average speeds of the test load through the Hazard Course.
2. Inspection did not reveal any damage to the JMIP.

2. ROAD TRIP:

Remarks:

1. The Road Trip was conducted between the Hazard Course Passes #2 and #3.
2. Inspection following the Road Trip revealed no damage or movement of the JMIP.

3. PANIC STOPS: Testing was not required since the load was rail impact tested.

4. HAZARD COURSE:

Pass No.	Elapsed Time	Avg. Velocity (mph)
3	24 Seconds	6
4	25 Seconds	6

Figure 11.

Remarks:

1. Figure 11 lists the average speeds of the test load through the Hazard Course.
2. Inspection did not reveal any damage to the JMIP.

5. WASHBOARD COURSE:

Remarks: Inspection following the Washboard Course revealed no damage to the JMIP.



Photo 14. Washboard Course Testing of the JMIP

B. CONCLUSIONS:

1. The JMIP, as currently designed, is adequate, to be used to transport the Navy JMICs with ammunition when secured directly to the trailer.

2. The purpose of the testing was to identify the adequacy of the JMIP for demonstration use and not final approval. Testing has identified deficiencies with the current design.

3. The operational condition of the JMIP should be closely monitored during the demonstration. Also, the Defense Ammunition Center, Transportation Engineering Division, shall be consulted for the ammunition loading and bracing instructions.

5.4

Test Specimen: SEABOX Joint Modular Intermodal Platform Unit #4 Secured
Directly to the Railcar

Payload: 8 Navy Joint Modular Intermodal Containers (JMIC).

Testing Date: 24 April 2007

Gross Weight: 26,360 lbs (Including JMIP and JMICs).

A. RAIL TEST.



Photo 15. Rail Impact Testing of the JMIP (Prior to Testing)

Description	Weight
Flatcar Number: DODX 42353	85,000 lbs.
JMIP with JMICs	26,360 lbs.
M1 Flatrack with MLRS Pods	28,265 lbs.
Total Specimen Wt.	139,625 lbs.
Buffer Car (four cars)	257,900 lbs.

Figure 12.

Remarks: Figure 12 lists the test components and weights of the items used during the Rail Impact Tests.

Impact Number	Avg. Velocity (mph)
1	4.8
2	6.3
3	8.5
4	5.8
5	8.7

Figure 13.

Remarks:

1. Figure 13 lists the average speeds of the specimen car immediately prior to impact with the anvil. Impact #5 is the reverse impact.
2. Impact #4 was determined to be a “no test” due to the insufficient velocity at impact. The test was repeated.
3. Following Impact # 4 one JMIC door lock was partially disengaged.



Photo 16. Partially Disengaged JMIC Door Lock

4. The locks on some of the JMICs were difficult to unlock upon completion of the testing. The use of a pry bar was sometimes required to disengage the locks.

B. CONCLUSIONS:

1. The JMIP, as currently designed, is adequate to be used to transport the Navy JMICs with ammunition when secured directly to the railcar.

2. The purpose of the testing was to identify the adequacy of the JMIP for demonstration use and not final approval. Testing has identified deficiencies with the current design.

3. The operational condition of the JMIP should be closely monitored during the demonstration. Also, the Defense Ammunition Center, Transportation Engineering Division, shall be consulted for the ammunition loading and bracing instructions.

PART 6 – DRAWINGS

The following drawing represents the load configuration that was subjected to the test criteria.

PART 6 – DRAWINGS

The following drawing represents the load configuration that was subjected to the test criteria.

TEST SKETCH

LOADING AND BRACING OF JOINT MODULAR INTERMODAL CONTAIN- ERS (JMICS) ON THE JOINT MODU- LAR INTERMODAL PLATFORM (JMIP)

THIS FIVE PAGE DOCUMENT DEPICTS NAVY JMIC
ON A SEABOX JMIP FOR TRANSPORTABILITY TEST-
ING

PREPARED DURING APRIL 2007 BY:
U.S. ARMY DEFENSE AMMUNITION CENTER
ATTN: SJMAC-DET
POC: MICHAEL BARTOSIAK
DSN 956-8083
COMM (918) 420-8083
FAX (918) 420-8811
E-MAIL: MICHAEL.BARTOSIAK@US.ARMY.MIL

LAURAA. FIEFFER
CHIEF, TRANSPORTATION ENGINEERING DIVISION

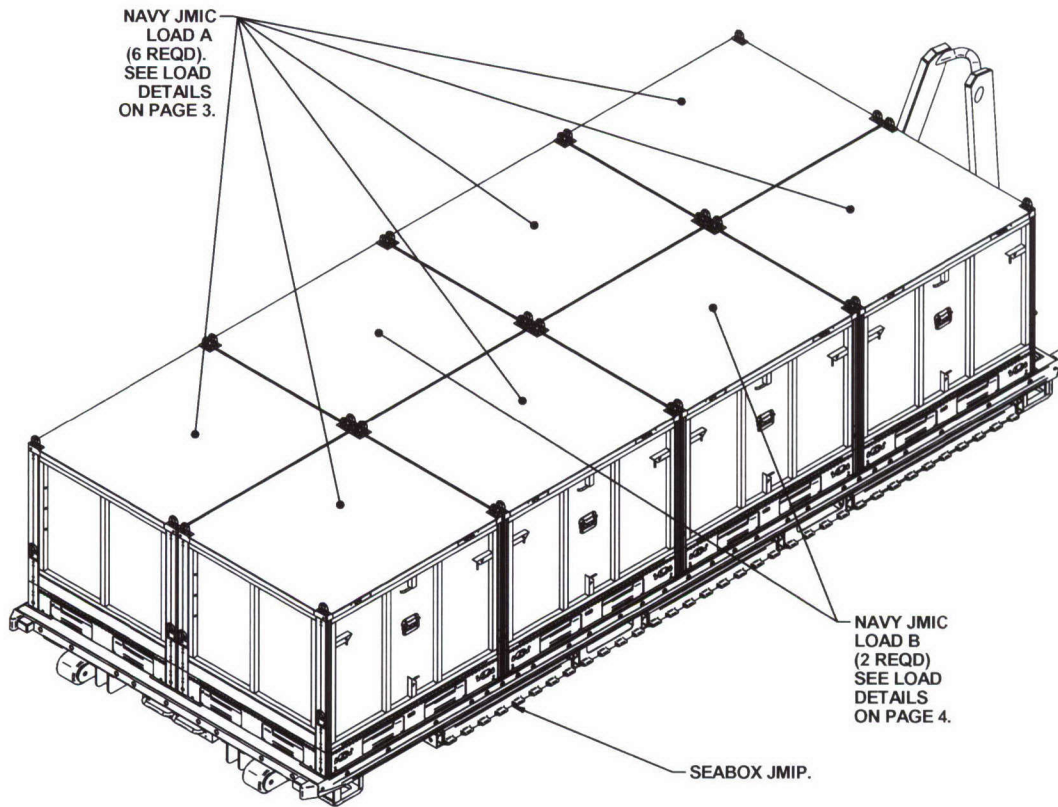

ISOMETRIC VIEW

LOAD AS SHOWN

<u>ITEM</u>	<u>QUANTITY</u>	<u>WEIGHT (APPROX)</u>
NAVY JMIC LOAD A	6	17,826 LBS
NAVY JMIC LOAD B	2	4,022 LBS
JMIP		4,240 LBS
TOTAL WEIGHT		26,088 LBS (APPROX)

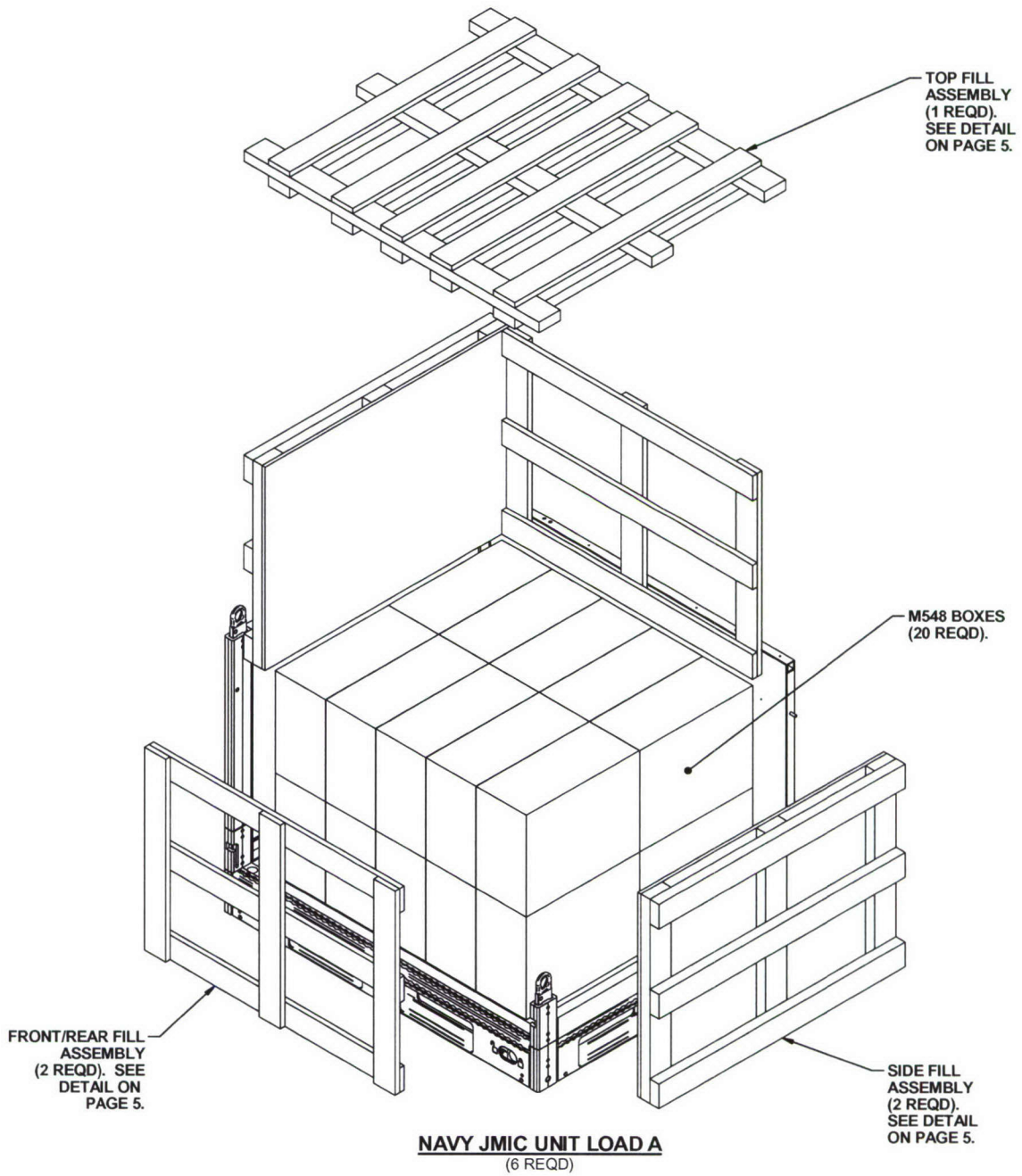

NAVY JMIC UNIT LOAD A
(6 REQD)

20 M548 BOXES @ 125 LBS - - - - - 2,500 LBS
 DUNNAGE - - - - - 146 LBS
 CLOSED PANEL NAVY JMIC - - - - - 325 LBS

TOTAL WEIGHT - - - - - 2,971 LBS (APPROX)
 CUBE - - - - - 56.4 CU FT (APPROX)

BILL OF MATERIAL		
LUMBER	LINEAR FEET	BOARD FEET
1" x 4"	52	18
2" x 4"	64	43
NAILS	NO. REQD	POUNDS
3d (1-1/4")	84	.16
6d (2")	60	.35
10d (3")	36	.54
NAVY PANEL JMIC - - - - -	1 REQD - - - - -	325 LBS
1/2 PLYWOOD - - - - -	17 SQ FT - - - - -	23 LBS

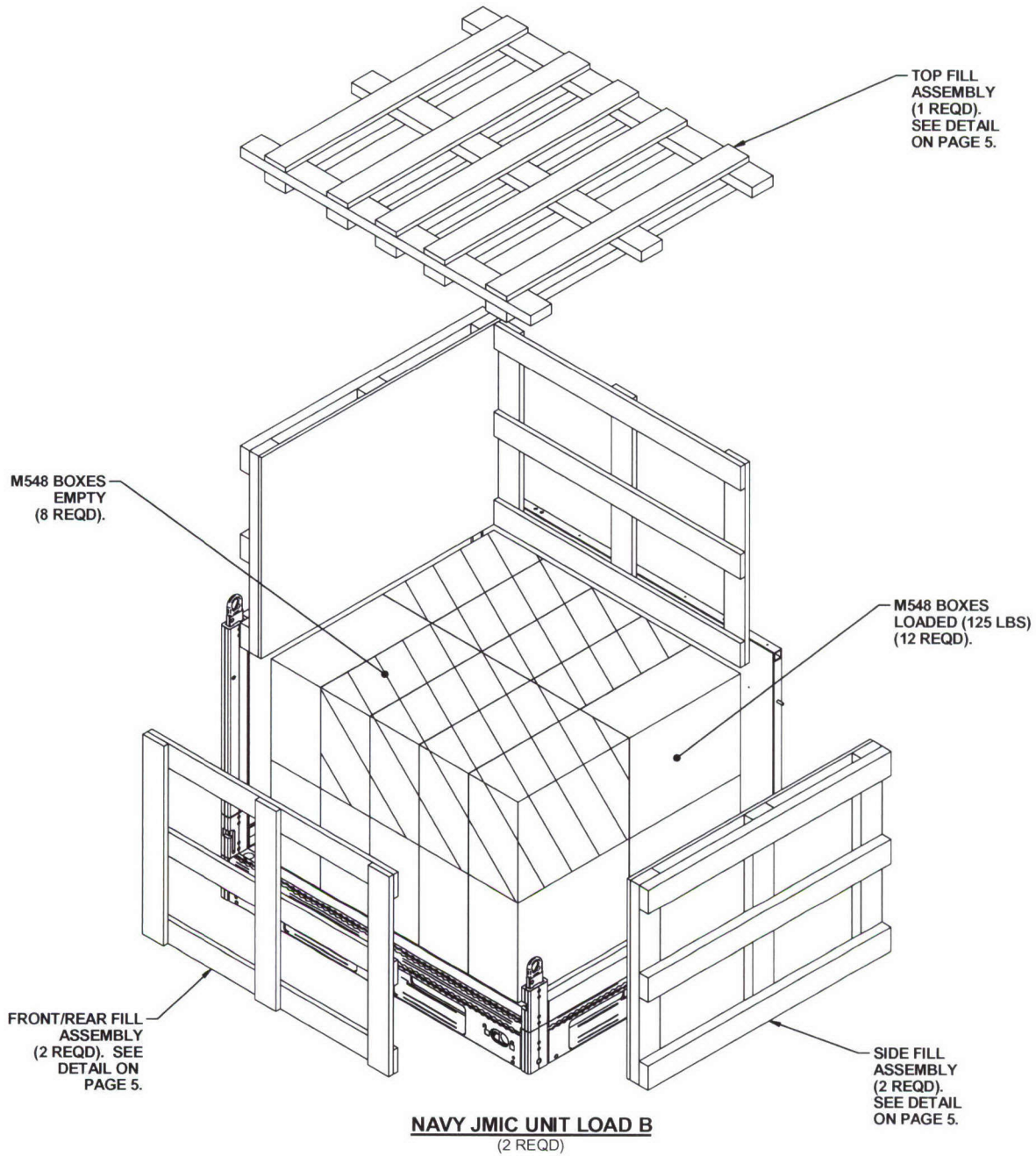

NAVY JMIC UNIT LOAD B
(2 REQD)

12 M548 BOXES @ 125 LBS	-----	1,500 LBS
8 M548 BOXES (EMPTY)	-----	40 LBS
DUNNAGE	-----	146 LBS
CLOSED PANEL NAVY JMIC	-----	325 LBS
<hr/>		
TOTAL WEIGHT	-----	2,011 LBS (APPROX)
CUBE	-----	56.4 CU FT (APPROX)

BILL OF MATERIAL		
LUMBER	LINEAR FEET	BOARD FEET
1" X 4"	52	18
2" X 4"	64	43
NAILS	NO. REQD	POUNDS
3d (1-1/4")	84	.16
6d (2")	60	.35
10d (3")	36	.54
NAVY PANEL JMIC	1 REQD	325 LBS
1/2 PLYWOOD	17 SQ FT	23 LBS

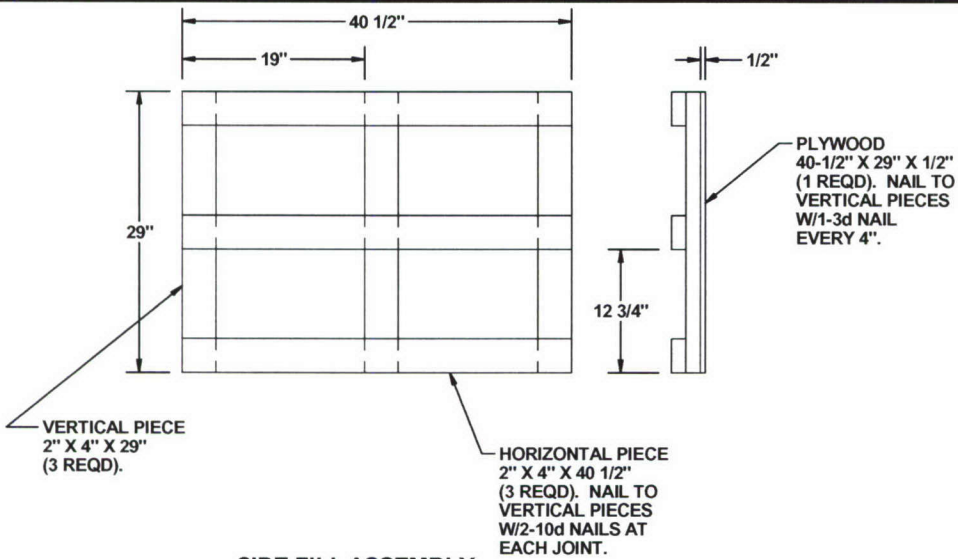

VERTICAL PIECE
2" X 4" X 29"
(3 REQD).

HORIZONTAL PIECE
2" X 4" X 40 1/2"
(3 REQD). NAIL TO
VERTICAL PIECES
W/2-10d NAILS AT
EACH JOINT.

SIDE FILL ASSEMBLY
(2 REQD)

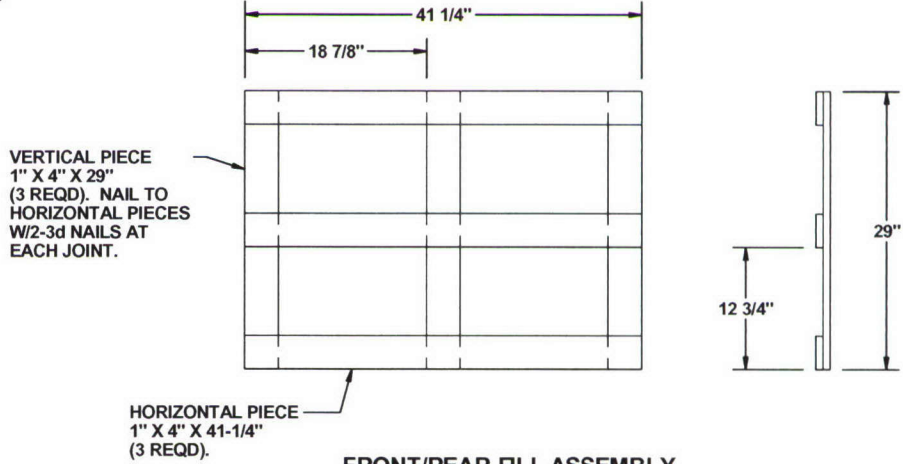

FRONT/REAR FILL ASSEMBLY
(2 REQD)

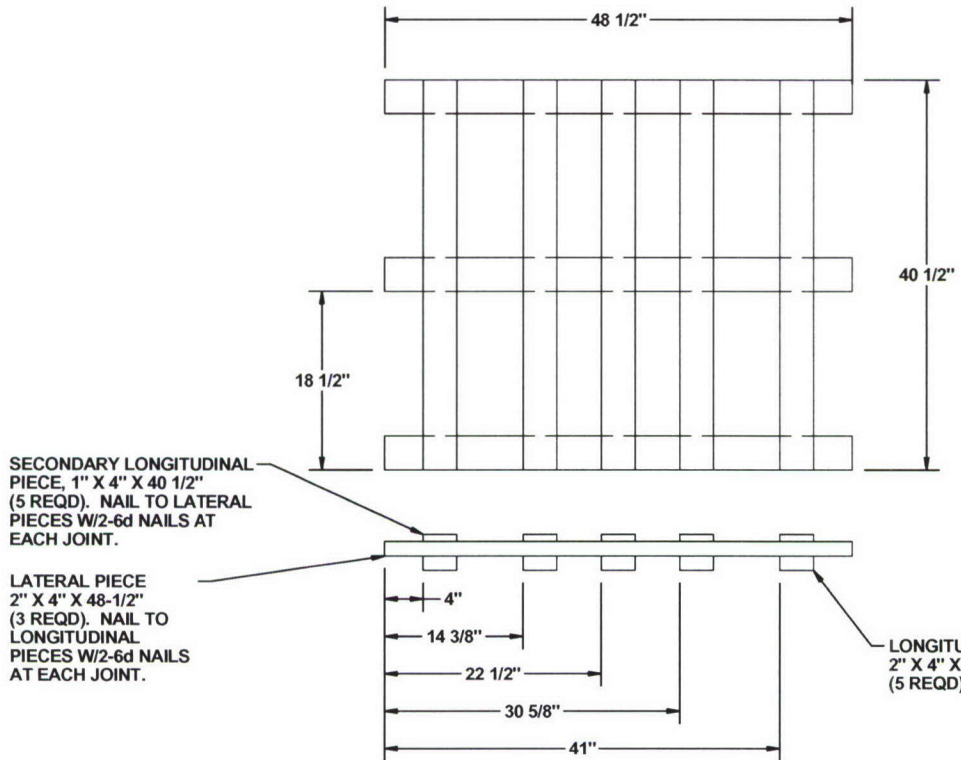

TOP FILL ASSEMBLY
(1 REQD)