



# NAVAL POSTGRADUATE SCHOOL

MONTEREY, CALIFORNIA

## THESIS

**SYSTEMS ANALYSIS AND MODELING OF U.S. NAVY  
SUBMARINE REPAIR OPERATIONAL TARGET (OPTAR)  
PROCESSES**

by

Lynn A. Trujillo

December 2007

Thesis Advisor:  
Second Reader:

Tarek Abdel-Hamid  
Phil Candreva

**Approved for public release; distribution is unlimited**

THIS PAGE INTENTIONALLY LEFT BLANK

REPORT DOCUMENTATION PAGE			Form Approved OMB No. 0704-0188
Public reporting burden for this collection of information is estimated to average 1 hour per response, including the time for reviewing instruction, searching existing data sources, gathering and maintaining the data needed, and completing and reviewing the collection of information. Send comments regarding this burden estimate or any other aspect of this collection of information, including suggestions for reducing this burden, to Washington headquarters Services, Directorate for Information Operations and Reports, 1215 Jefferson Davis Highway, Suite 1204, Arlington, VA 22202-4302, and to the Office of Management and Budget, Paperwork Reduction Project (0704-0188) Washington DC 20503.			
1. AGENCY USE ONLY (Leave blank)	2. REPORT DATE December 2007	3. REPORT TYPE AND DATES COVERED Master's Thesis	
4. TITLE AND SUBTITLE Systems Analysis and Modeling of U.S. Navy Submarine Repair Operational Target (OPTAR) Processes		5. FUNDING NUMBERS	
6. AUTHOR(S) Lynn A. Trujillo		8. PERFORMING ORGANIZATION REPORT NUMBER	
7. PERFORMING ORGANIZATION NAME(S) AND ADDRESS(ES) Naval Postgraduate School Monterey, CA 93943-5000		10. SPONSORING/MONITORING AGENCY REPORT NUMBER	
9. SPONSORING /MONITORING AGENCY NAME(S) AND ADDRESS(ES) N/A		11. SUPPLEMENTARY NOTES The views expressed in this thesis are those of the author and do not reflect the official policy or position of the Department of Defense or the U.S. Government.	
12a. DISTRIBUTION / AVAILABILITY STATEMENT Approved for public release; distribution is unlimited		12b. DISTRIBUTION CODE	
13. ABSTRACT (maximum 200 words) This work performed a systems level analysis of Submarine repair budgeting and spending in an effort to articulate the unique behaviors of this combined system of budgeting, supply chain management, and spending control. Current Navy policies, procedures, and budget forecast methods were studied to develop the basic causal relationships of the budgeting and spending behavior in order to develop a basic model of the system. The effects of feedback and delays inherent in the system structure were analyzed to determine overall system amplification and oscillation potential in spending behavior is possible given various changes to inputs. Observations over spending data recorded from 1996 to 2006 for the submarine force are analyzed against the knowledge of the system dynamics to determine if this real behavior can be successfully reconstructed in the model.			
14. SUBJECT TERMS Operational Target, OPTAR, Budget, Spending, Submarine, Funding, Model, System Dynamics, Systems Analysis		15. NUMBER OF PAGES 91	
		16. PRICE CODE	
17. SECURITY CLASSIFICATION OF REPORT Unclassified	18. SECURITY CLASSIFICATION OF THIS PAGE Unclassified	19. SECURITY CLASSIFICATION OF ABSTRACT Unclassified	20. LIMITATION OF ABSTRACT UU

NSN 7540-01-280-5500

Standard Form 298 (Rev. 2-89)  
Prescribed by ANSI Std. Z39-18

THIS PAGE INTENTIONALLY LEFT BLANK

**Approved for public release; distribution is unlimited**

**SYSTEMS ANALYSIS AND MODELING OF U.S. SUBMARINE REPAIR  
OPERATIONAL TARGET (OPTAR) PROCESSES**

Lynn A. Trujillo  
Lieutenant, United States Navy  
B.A., North Carolina State University, 2000

Submitted in partial fulfillment of the  
requirements for the degree of

**MASTER OF BUSINESS ADMINISTRATION**

from the

**NAVAL POSTGRADUATE SCHOOL  
December 2007**

Author: Lynn Trujillo

Approved by: Tarek Abdel-Hamid  
Thesis Advisor

Phil Candreva  
Second Reader

Robert N. Beck  
Dean, Graduate School of Business and Public Policy

THIS PAGE INTENTIONALLY LEFT BLANK

## **ABSTRACT**

This work performed a systems level analysis of Submarine repair budgeting and spending in an effort to articulate the unique behaviors of this combined system of budgeting, supply chain management, and spending control. Current Navy policies, procedures, and budget forecast methods were studied to develop the basic causal relationships of the budgeting and spending behavior in order to develop a basic model of the system. The effects of feedback and delays inherent in the system structure were analyzed to determine overall system amplification and oscillation potential in spending behavior is possible given various changes to inputs. Observations over spending data recorded from 1996 to 2006 for the submarine force are analyzed against the knowledge of the system dynamics to determine if this real behavior can be successfully reconstructed in the model.

THIS PAGE INTENTIONALLY LEFT BLANK

# TABLE OF CONTENTS

I.	INTRODUCTION.....	1
A.	OVERVIEW AND SCOPE OF THIS STUDY.....	3
B.	CONTENT OF THIS THESIS WORK.....	5
C.	DYNAMIC HYPOTHESIS.....	6
II.	PREVIOUS STUDIES OF OPTAR AND O&M PROCESSES .....	11
III.	ANALYSIS OF NAVY VAMOSOC REPAIR OPTAR DATA.....	15
IV.	FORMING A CAUSAL DIAGRAM OF THE OPTAR PROCESS.....	19
A.	DEMAND FOR REPAIR PARTS.....	19
B.	REPAIR PARTS SUPPLY CHAIN MANAGEMENT .....	23
C.	BUDGET AND SPENDING PLAN PROCESSES .....	26
V.	MODEL DEVELOPMENT IN THE STELLA® SOFTWARE .....	31
A.	DEFECT GENERATION AND REPAIR PARTS DEMAND .....	33
B.	SUPPLY CHAIN MANAGEMENT.....	37
C.	BUDGET FORMULATION, CORRECTION, AND SPENDING CONTROL.....	41
VI.	MODEL SENSITIVITY ANALYSIS .....	49
A.	SENSITIVITY TO SUPPLY CHAIN AVERAGING TIMES .....	50
B.	SENSITIVITY TO INVENTORY CORRECTION TIMES.....	52
C.	SENSITIVITY TO BUDGET AVERAGING TIMES.....	54
D.	IMPLICATIONS OF THE SENSITIVITY ANALYSIS.....	57
VII.	CONCLUSIONS.....	65
A.	AREAS FOR FURTHER RESEARCH AND MODEL IMPROVEMENT.....	68
	APPENDIX. MODELING EQUATIONS .....	71
	LIST OF REFERENCES.....	73
	INITIAL DISTRIBUTION LIST .....	75

THIS PAGE INTENTIONALLY LEFT BLANK

## LIST OF FIGURES

Figure 1.	Submarine RP OPTAR Expenditures 1996 to 2004 .....	16
Figure 2.	Defect Generation / Removal and Stock Level Structure .....	22
Figure 3.	Repair Parts Supply Chain Management Process .....	25
Figure 4.	Budget Adjustment and Obligation Target Process .....	29
Figure 5.	Basic Stella Stock and Flow Model.....	31
Figure 6.	Example Stella Model Printout of System Parameters .....	32
Figure 7.	Defect Generation and Repair Parts Demand Sub-model.....	34
Figure 8.	Defect Generation Response to a 10% Rise in OPTEMPO .....	36
Figure 9.	PMS and Repair Demand Rate Response to OPTEMPO Rise .....	36
Figure 10.	Supply Chain Management Sub-Model.....	37
Figure 11.	Supply Chain Level Response to 10% Demand Increase .....	40
Figure 12.	Supply Chain Rate Response to 10% Demand Increase .....	40
Figure 13.	Budget Formulation and Spending Control Sub-Model .....	42
Figure 14.	Budget Forecast Components and Backlog Correction to a 10 Percent Demand Increase.....	45
Figure 15.	Mid Year Corrections to a 10 Percent Demand Increase .....	45
Figure 16.	Indicated vs. Real Order Rate for Ten Percent Demand Rise .....	46
Figure 17.	Budget Authority Projections Based on Three, Six, and 12 Month Supply Chain Averaging Times .....	51
Figure 18.	Budget Authority Projections Based On Six, Twelve, and Eighteen Month Inventory Correction Times.....	53
Figure 19.	Budget Authority Projections Based on Twelve, Twenty-Four, and Thirty-Six Budget Averaging Times .....	56
Figure 20.	Model Response To Exogenous Funding For Increasing Demand Transient .....	61

THIS PAGE INTENTIONALLY LEFT BLANK

## LIST OF TABLES

Table 1.	Repair OPTAR Codes and Associated VAMOSC Element. ....	15
Table 2.	Amplification Characteristics of Budget Authority With Varying Supply Chain Averaging Times .....	52
Table 3.	Amplification Characteristics With Six, Twelve, and Eighteen Month Inventory Correction Times .....	54
Table 4.	Amplification Characteristics With Twelve, Twenty-Four, and Thirty- Six Month Budget Averaging Times .....	57

THIS PAGE INTENTIONALLY LEFT BLANK

## **ACKNOWLEDGMENTS**

I would like to acknowledge the support of Professor Abdel-Hamid and Professor Candreva throughout this work. Their patience with my many questions and comments as well as their superb knowledge and insights helped immensely throughout this process. I would also like to acknowledge my loving wife and children who had to put up with a continuous dialogue about budgets, spending, and modeling for the last several months in order for me to complete this work.

THIS PAGE INTENTIONALLY LEFT BLANK

## I. INTRODUCTION

Systems citizenship starts with seeing the systems that we have shaped and which in turn shape us

-- Peter Senge, The Fifth Discipline

For as long as there has been a need to allocate limited resources to meet the needs of an organization there has been a need to develop a systematic method to plan and project future requirements. For financial resources the development of budgeting systems that can consistently and accurately predict future funding levels play an essential role in meeting the current and future needs of the organization. Inaccuracies in any budget process can lead to unwanted surpluses or shortages in financial resources that are necessary to meet operational commitments. Shortages in financial resources limit the ability of an organization to buy necessary items that directly or indirectly support short term or long-term objectives. Surpluses in these same resources for a single budget function limit the ability of the organization to efficiently allocate money into the other budget functions thereby limiting the ability to meet requirements in those areas as well.

When discussing accuracy in the context of budgeting different disciplines of thought emerge. One common approach to developing accurate cost prediction is through the use of statistical, analogous, or other cost estimation methods. These methods result in the formulation of a cost estimation relationship between measurable parameters and the resultant cost of performing a specific function or group of functions. Several factors can affect the accuracy of such a cost estimation function as well as the consistency of predictions. These include but are not limited to the strength of the causal relationships observed between measured input variables and the output observed cost level.

Regardless of the overall accuracy or consistency of any cost estimation relationship model the outcome of the model can be considered a 'snapshot' one specific period in time. Models of this type cannot capture the time-series behaviors the spending, projection, or correction to budget processes that occur throughout the execution phase of any spending plan. Other things that can be a source of error in static cost estimation models are that these models are limited by the accuracy and timeliness of input information. Longer time spans for information updates and lower quality of input information will yield poorer predictions about future events. Two potential outcomes of future events that can be attributed to time spans are oscillation and amplification of the predicted results.

Amplification represents a pattern over time of over compensations based on indicated normal trends or variability in input variables. If a system over compensates for an upward trend then it can overestimate budget requirements beyond the actual change in resource needs. Amplification can occur in any system where there is a significant delay between the input and action processes. Oscillation can occur whenever there are re-enforcing and balancing behaviors that compete within the numerous system processes at work. At any given time in a transient condition the relative effect of the re-enforcing behaviors may be greater than, less than, or equal to balancing behaviors. Re-enforcing behavior, also known as positive feedback loops, tends to cause the output of the process to change in the same direction as the change in input. Balancing behavior, also known as negative feedback loops, tends to cause the opposite effect. The relative relationship between the numerous positive and negative feedback effects can result in an oscillation around a steady state condition fall below and rise above the desired output. This oscillation may coalesce to the desired output level or grow worse over time depending on the unique system dynamics and structure.

Modern systems theory indicates that by reproducing the fundamental operational behaviors of both the budgeting process and the spending process it is possible to gain insights into the impact that information delay and feedback quality will have on the prediction consistency and accuracy of any budgeting system. This method of budget analysis focuses more on the behaviors in the system rather than the absolute accuracy of the cost estimation relationship in use. Systems analysis and subsequent simulations that can be run in dynamic models also allow for a range of controlled experimentation to test the effects of potential policy changes that could affect the system structure or decision rules. Simulation models can also be a useful training and learning tool in that policy and procedure decisions can be tested to determine potential effects on the current system. The systems analysis process also requires a scrutiny of the effect or behaviors that policy and procedure may be intentionally or unintentionally creating and may lead to a better understanding of potential areas to improve in the budget and/or execution processes.

#### **A. OVERVIEW AND SCOPE OF THIS STUDY**

This thesis performs a systems analysis and dynamic model development for the budgeting and execution of Operational Target (OPTAR) funds for repair and repair parts on board submarines of the United States Navy. The overall result is the development of a “proof of concept” simulation model that can emulate the major behaviors of both budgeting and spending as they change over time. These changes can occur as a result of changes in both demand, supply system adjustments, and external funding. By emulating the spending and budgeting behaviors this model hopes to provide insights into why previous studies into causal relationships between operational activity and expenditures may not have provided conclusive findings. As a general process planned maintenance and repairs are funded through an allotment from the Navy’s portion of the annual department of defense appropriations act. As these ships conduct maintenance and repairs throughout the fiscal year obligations are

incurred that reduce the remaining balance of available funds for the rest of the budget period. The Navy Comptroller, based on the cost experience gained from previous budget periods and forecasted operational commitments, programs future budget levels to meet force requirements. This constitutes the basic budget cycle that will be modeled and developed as a part of this work.

The OPTAR funds associated with repair and repairable Items is most commonly referred to as RP OPTAR and will be referred to as such in the remainder of this work. The two major classes of submarines in use by the United States Navy, namely the Los Angeles (SSN-688) and Ohio (SSBN-726) classes of ships are the specific focus group within the submarine force and will be referred to generically as Submarines in the following discussions. The focus in this specific OPTAR type and the specific ship classes is due in part to the availability of spending history, the relative majority of these two classes of ships in the total submarine force inventory, and the author's experience with the maintenance and repair processes at the ship level.

The insights gained into the budget and execution process as a result of this work may however be readily applied to other types of submarines and other Navy vessels since the maintenance and OPTAR processes are similar in many respects on those ships or ship classes. Furthermore the study of OPTAR processes only represents a portion of the total funding for all operations and maintenance activities within the Navy submarine force. Therefore the mechanics of how costs are incurred, and the demand for maintenance, cannot be readily applied to all budget areas and this study does not attempt to do so. The models developed in this study can however generically relate demand from any source to ultimate budget behavior and therefore the lessons learned from this work can be used to understand the unique combination of federal spending controls and supply chain management for any larger Submarine Force or Navy process.

The Navy Visibility and Management of Operating and Support Costs (VAMOSC) database was the source of the RP OPTAR expenditure levels used as the test data in this study. A period of ten fiscal years from 1996 to 2006 was utilized to develop or scrutinize patterns observed in spending behavior over that period. The VAMOSC data covers a larger range of time (approx 24 years) but going back farther than 10 years was determined to be unnecessary since many of the policies and procedures that govern budget development have changed and evolved over time to the current forms. In addition it is the specific interest of this study to look at a specific change in spending behavior that has occurred since the inception of the Global War on Terror. To do that analysis the five years prior to fiscal year (FY) 2001 and the five years after FY 2001 were felt to be sufficient to illustrate the change in behavior in this regard. More on the specific behavior pattern shift will be discussed in later sections of this work.

To develop the causal relationships that form the basis for the dynamic simulation model the current written policies and procedures in use were studied and referenced. The budget and execution processes however involve many intangible interactions between operational commanders, supply chain managers, and budget programmers. Many of these interactions are vital to the successful matching of needs to resources and often fall outside of the limits of the existing written guidance. This model is therefore limited in that it cannot capture all of the effects of human judgment, interpretation, and communications that occur in this real world process. Through the building of a simulation model however this work can form a valuable decision support tool for those people involved in the process because it may articulate behaviors and patterns that are the result of complex interactions that traditional, "static", support tools cannot.

## **B. CONTENT OF THIS THESIS WORK**

Chapter II of this work is a summary of the basic background research that has been done in the area of Operations and Maintenance (O&M) and OPTAR budget processes over the last several years. Chapter III discusses the

methodology that was used to obtain RP OPTAR data from the Navy VAMOSC database and the association of submarine level OPTAR fund codes with VAMOSC data elements. Also in this chapter an analysis of potential behaviors in expenditures is discussed. Chapter IV develops the causal relationships and structure of both the spending and budgeting processes associated with RP OPTAR. Included in this discussion is an explanation of the use and methods employed by the Navy Comptroller's Ship Operations Model cost estimation program.

Chapter V provides the discussion of how the causal relationships developed were formulated into a dynamic model of stocks and flows using the Stella® programming software. In this chapter basic experiments are performed to articulate the system responses to basic input changes. Chapter VI performs additional sensitivity analysis of the as built model to understand the implications of adjustments to controllable parameters on the model responses. Chapter VII provides a conclusion and areas for model improvement and additional research.

### **C. DYNAMIC HYPOTHESIS**

As a basic measure of readiness a submarine, as with any type of weapons platform, must be able to conduct any and all missions assigned to it by higher authority when such as need arises. This most basic form of readiness can be called operational readiness. Modern submarines contain millions of parts within hundreds of complex mechanical, electrical, and electronic systems. Within the space and weight limits of the submarine's design thousands of repair parts are stored on board and constitute the ships inventory level. In general the amounts and types of repair parts on board are determined by historic demand, the unique equipment and systems configurations, and a base level of parts always maintained to support critical propulsion, power generation, weapon systems, navigation, and life support. Parent squadron and groups of these ships also maintain ashore supply facilities to house and deliver thousands of other types of parts to the submarines to replenish on board inventories as they

are used or to supply parts that did not meet historic demand on board an individual ship but are now necessary due to unforeseen maintenance requirements. If emergent conditions arise where the parent group or squadron cannot fill and order from it's inventory it can obtain parts from another ship, squadron, or group as necessary to meet the demand.

Therefore as a total submarine force there is a total inventory of parts to fulfill the aggregate demand for planned and unplanned maintenance requirements. A basic measure of 'readiness' as it applies to the repair parts allowances can be described as 'material readiness'. For the submarine force the amount of repair parts inventory currently maintained amongst all the ships, groups, and squadrons reflect the need to meet both planned and contingent future demand. In this context material readiness can be understood as the total available repair parts in the system, relative to the target levels (based on experience) that are required in inventory. If inventory levels drop and are not replenished there is a possibility of a shortfall occurring in some critical need area. This may result in the inability of a ship or group of ships from being able to fulfill operational mission requirements while awaiting repair parts. Therefore in a broader context material readiness can also be understood as a unique form of operational readiness since the ability of the logistical system to meet the needs of the submarines directly affects operational capabilities.

The concept of supply chain management, and the effects of improper or inadequate execution thereof, are well-documented subjects in the modern business literature. Systems dynamics theory has been able to articulate the undesirable effects of information delay, information error, and cause-and-effect relationships on the performance of supply chain management systems. These efforts have led to a better understanding of the complex reactions that supply chains have to external stimulus and demand and have resulted in overall improvements to the process. Modern supply chain management also includes the study of forecasting of future requirements in the budgeting phase of the business cycle. Budgeting is also a very critical component in the overall

effectiveness of the supply chain management because it aligns the right amount of money or assets to fulfill order requirements. However in the typical supply chain (corporate) the budget represents a “best guess” of future requirements and is based on very accurate assessments of demand. Spending variance from the budgeted amounts is expected and routinely occurs and the amount of variance is studied and used to improve forecasting and execution methods for future periods.

The submarine force faces many of the same challenges that any modern business faces when attempting to manage its repair parts supply chain. However as a federal agency the method of budgeting and spending control are fundamentally different than most modern business approaches. Due to the much less predictable nature of submarine operations it is fundamentally more difficult to precisely forecast future budget needs. Unlike a normal business entity no market exists for submarine operations that can be easily understood or forecast. Therefore natural demand variance for repair parts year to year can be substantially higher than a modern business would tolerate. As a result the submarine force must be able to meet unplanned requirements with some level of assurance by maintaining a level of inventory large enough to meet current and contingent needs within reasonable limits.

Also unlike a normal business entity spending variance cannot be a unique learning tool in the budgeting process because spending rates are tightly controlled to ensure compliance with the requirements of public law. Spending over levels appropriated by law is not possible without specific approval and formal budget changes to the planned budget amounts. Spending under levels appropriated by law is also undesirable because it undermines credibility in justifying future budget requests. Finally, as a larger part of the Plans, Policy, Budgeting, and Execution processes the length of time between budget request (and changes thereto) and spending authority is significantly longer than most corporate systems.

It is the hypothesis of this work that these behavior mechanisms, the need to maintain a large inventory level to meet current material readiness through adequate material inventory, the need to forecast future budget levels and make corrections with long lead times, the tight spending controls in place to comply with public law, and the less predictable nature of submarine operational planning all lead to significant errors in financial forecasting and budgeting over time in the supply chain management system. Two fundamental system dynamics outcomes that can occur are oscillation and amplification of the system response to changes in demand. Furthermore external forces outside of the supply chain management process that would add or remove funding from the system may create additional amplification or oscillation potential in year to year spending.

The remainder of this thesis work shall develop the system that includes the behavioral elements discussed above in order to test this dynamic hypothesis against actual observed spending patterns. The following chapter discusses previous research into cost estimation of both OPTAR and Operations and Maintenance (O&M) accounts for various Navy components.

THIS PAGE INTENTIONALLY LEFT BLANK

## II. PREVIOUS STUDIES OF OPTAR AND O&M PROCESSES

For the last two decades several research efforts into ways to improve the accuracy and consistency of Navy budgets for both OPTAR and larger Operations and Maintenance accounts have been done. This section provides an overview of these research efforts and the results that have been obtained through that body of work. Also included in this section is the summary of findings from the only Congressional Budget Office research into Navy O&M budgeting processes.

In 1987 Williams performed a study that investigated the nature of OPTAR expenditures for the FF-1052 and CG-27 ship classes. His work attempted to utilize the OPTAR expenditure records to determine if a parametric cost estimation relationship could be formulated. Williams was unable to conclusively determine relationships that were statistically significant. He went on to further state that a possible explanation for this was a lack of formal records of OPTAR expenditures for a long enough period.<sup>1</sup> At that time there was no formal centralized record keeping location for OPTAR obligations. The current Navy VAMOSC system, maintained by the Naval Center for Cost Analysis, did not come on line until 1992. Kuker and Hansen in 1988 attempted to determine if a causal relationship existed between operating schedules and overall OPTAR obligation patterns for a three year period. The study found that although general patterns could be inferred between operating schedules and OPTAR costs that the model failed to accurately predict costs at an individual ship or ship class level.<sup>2</sup>

In 1989, the Congressional Budget Office (CBO) performed an investigation into the Navy Steaming Days Program. The steaming days program is the method the Navy utilized at that time to determine future resource

---

<sup>1</sup> Williams, 1987, p. 27.

<sup>2</sup> Kuker and Hansen, 1988, p. 63.

levels and to validate expenditures of O&M funds. A steaming day is a unit of activity that the Navy utilized at the time to allocate O&M expenses and to measure effectiveness of resource usage. Although the central focus of the CBO was to analyze the effectiveness of the Navy in relating resource allocations to measurable readiness objectives the study did conclude that the Navy did not have a good understanding of the 'cost' of operations or readiness levels and therefore heavily relied on past budget execution data instead of true cost projection to meet readiness or operational needs.<sup>3</sup>

In 1993, a research effort by Ting attempted to utilize manpower, material, maintenance, and overhaul costs to develop a basic cost forecast model of Operations and Support (O&S) costs for Navy ships. The study shows that manpower levels and employment were found to have the best predictive ability in determining overall O&S cost levels for Navy ships. Outside of manpower levels however Ting was unable to show significant cost driver relationships for the other factors and O&S costs overall.<sup>4</sup> An OPTAR cost allocation model study by Catalano in 1998 attempted to create a cost estimation relationship between several operational factors and overall repair parts costs for Pacific fleet surface ships. His model used operational factors such as time before overhaul, months of deployment in the fiscal year, and other explanatory variables. The study failed to produce conclusive or significant relationships, as measured by regression analysis, in the developed model.

Brandt developed a parametric cost model in 1999 to attempt to estimate O&S costs for non-nuclear surface ships. He used displacement, length, and crew manning levels as the independent variables in the study. The study concluded that there was an average O&S cost level that was constant for an individual ship class and that the age of the individual ship had no significant or measurable impact on the cost of operations.

---

<sup>3</sup> CBO / NSIAD-89-172, pp. 2-3.

<sup>4</sup> Ting, 1993, p. 54.

The Navy Comptroller's Ship Operations Model was analyzed by a MBA project group in 2003 to determine if improvements in this cost estimation model's accuracy and predictive consistency could be improved upon for non-nuclear surface ships. The group performed a statistical analysis of the certified obligation reports of the Type Commander in order to formulate linear models (single or multivariate) for each aspect of Navy O&M funding for the ships under study. They then compared their improved model's results to the Ship Operations Model results from 1998 to 2003. The study concluded that a general relationship existed between repair parts cost and operational activity.<sup>5</sup> The improved model proposed by the project group could match or improve forecast accuracy over the Ship Operations Model in all O&M funding categories. The model also improved consistency of results as measured by the Mean Average Percent Error (MAPE) measurement from the actual spending levels.<sup>6</sup> Submarine data was not included in the scope of this study due to the classified nature of operational schedules for the force.

In 2007, Rysavy performed a statistical analysis of the OPTAR costs associated with 688 class submarines in the Pacific fleet. Rysavy utilized obligation records from the Type Commander as well as expenditure information from the Navy VAMOSC database to determine if homeport location had a significant effect on overall OPTAR expenditures. The study concluded that no significant statistical difference in OPTAR costs existed in the three Pacific fleet submarine homeports that were included in the study. However during the statistical analysis of the OPTAR data a strong relationship was found between the deviation of observed OPTAR from the average OPTAR level and the deviation of observed operations tempo (OPTEMPO) from the average OPTEMPO for the ships in the study.

---

<sup>5</sup> Hascall et al., 2003, pp. 50-51.

<sup>6</sup> Ibid., p. 51.

In summary there have been several attempts to improve the cost estimation models in use by the Navy or to develop new models to explain the behavior of operations, maintenance, and support costs. No single study has been able to find a single or set of causal influences that can explain the overall pattern of spending that occurs over any period of fiscal years and/or ship classes. Because of this the Navy continues to, as was the case in 1989, rely on historical cost experience as the starting point and best indicator of future needs levels. Factors that drive cost can include operations tempo, manpower, or other parameters but no single or set of these variables has been able to fully explain the pattern of expenditures for any single ship, ship class, or for the overall force. The next area of this study analyzes record of expenditures was obtained from the Navy VAMOSC database and the correlations between Navy VAMOSC elements and the OPTAR funding codes for repair parts and repairables at the ship level.

### III. ANALYSIS OF NAVY VAMOSC REPAIR OPTAR DATA

As discussed in the previous section the Navy Visibility and Management of Operating and Support Costs is a database of expenditure records for all Naval vessels that is maintained by the Naval Center for Cost Analysis. Records for over 20 years are maintained for all Naval and Marine Corps weapon systems and include all direct cost elements, some indirect cost elements, and some other non-cost information such as flying hours, steaming information, manning levels, and platform age.<sup>7</sup>

In 2007, as a part of his research Rysavy was able to correlate the Navy Comptroller funding codes for Submarine repair OPTAR with the associated Navy VAMOSC database element descriptions by systematically comparing the recorded expenditure levels over several OPTAR codes and VAMOSC elements and compensating for the effects of inflation on the records. He was specifically able to determine the following relationship between Navy RP OPTAR codes and VAMOSC Elements:<sup>8</sup>

Category	Comptroller Fund Codes	Navy VAMOSC Database Element
Repair OPTAR (RP)	M3: Aviation depot level material purchased by the Ship Forces part of operating forces.	1.2.2.1: Repair Parts and Repairables – Cost of non-aviation depot level repairable and repair parts for use in maintenance of the ship and installed equipment.
	MB: Non-aviation depot level material in the Navy Stock Account, used to accomplish organizational level maintenance.	
	MR: Repair Parts used in the performance of organizational level maintenance on ship's equipment.	

Table 1. Repair OPTAR Codes and Associated VAMOSC Element.

<sup>7</sup> Navy VAMOSC website <http://www.navyvamosc.com/about.html>. Accessed October 2007.

<sup>8</sup> Rysavy, 2007, pp. 33-34.

Rysavy also determined that the M3 OPTAR funding category did not apply specifically to the individual submarines but was rather an OPTAR category utilized at the Squadron, Group, or higher levels.<sup>9</sup> From this linking in the 2007 study it is now possible to query the VAMOS database and retrieve with confidence the actual RP OPTAR expenditure data for the submarine force. The following represents the RP OPTAR expenditures for the Los Angeles Class submarines over a ten-year period from 1996 to 2004.

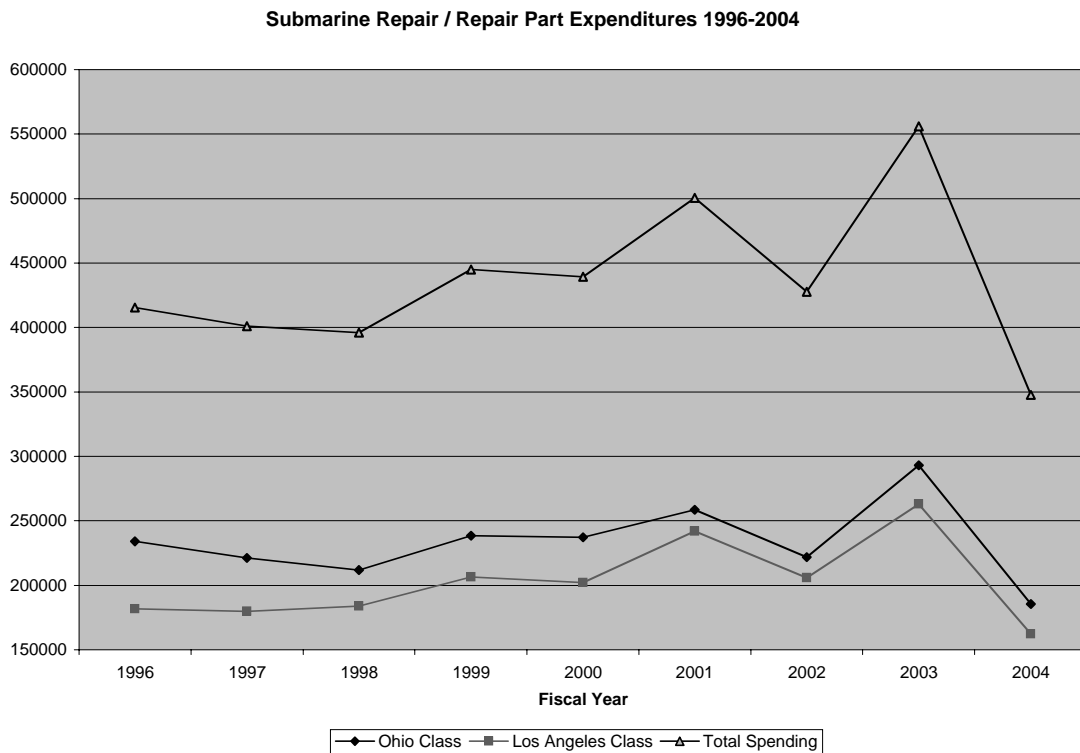

Figure 1. Submarine RP OPTAR Expenditures 1996 to 2004

The expenditure data exhibits characteristics of several outcomes of dynamic systems with feedback and delay mechanisms. The level of average expenditures for the submarines appears to oscillate around a central and more general trend. Oscillations are amongst the most common modes of behavior

<sup>9</sup> Rysavy, 2007, p. 36.

in dynamic systems.<sup>10</sup> Oscillations can be attributed in part to any significant delay in any part of a negative feedback loop of events. In general in any system where there is a measurement of some event, a goal level or expected outcome, and a corrective process may form a basic negative feedback cycle. If there is a delay in the measurement, reporting, or perception of spending, a delay in decision making about how to correct spending patterns, or a delay in executing the necessary changes to spending behavior then an oscillation around the desired outcome may result.

Another observation of the expenditure data is that, aside from a general pattern of oscillation, there appears to be a significant change in the amplitude of the expenditure patterns after 2001. The peak-to-peak changes in annual spending appear to be significantly higher after 2001 than before 2001. Another interesting artifact of the data is that spending levels are always relatively higher during the second year of the budget than the first. This can be seen as the general tendency for odd year spending levels to be higher than the even year levels that precede them.

It is apparent from a preliminary analysis of the expenditure data from the Navy VAMOS database that several symptoms of systems behavior such as oscillation and amplification may be occurring. The exact cause of the behavior may be due to several different influential factors in both the budgeting and spending processes coupled with information delay at one or more stages of the process. In addition there may be several re-enforcing and balancing causal loops that may be competing over time for dominance in the system response. The next section develops the basic causal structures at work in the budget, execution, and spending control processes that form the complete repair OPTAR cycle.

---

<sup>10</sup> Sterman, 2000, p. 114.

THIS PAGE INTENTIONALLY LEFT BLANK

## **IV. FORMING A CAUSAL DIAGRAM OF THE OPTAR PROCESS**

This section discusses the development of a causal diagram of the repair OPTAR budget and execution process that forms the basis for the construction of the dynamic model. The causal structure consists of three main elements that capture a portion of the larger OPTAR process. Each of these elements is discussed in more detail below.

### **A. DEMAND FOR REPAIR PARTS**

The demand for parts used by the Submarine force during the execution of operational requirements over the fiscal year consists of both a fixed and variable component. The fixed portion of the repair parts demand is attributable to the planned maintenance system (PMS) and the types and quantity of tasks that are determined by the ship's PMS schedule. Planned maintenance is designed primarily to find and replace defective equipment and parts prior to a large-scale failure of the component or system. The variable portion of the repair parts demand is attributable to both unplanned repairs / maintenance that occur as a result of failure of a component / system or as a result of replacing defective or worn parts in a component / system that were identified by planned maintenance.

Defects in equipment or components can occur due to many reasons. Equipment and part quality contribute to the rate at which defects are created in these systems. Sources of equipment defects in this category are largely based on design and manufacturing and are minimized through the stringent adherence to quality controls in the procurement process. Other defects can emerge as a result of improper compliance with operating procedures or operating the equipment beyond operational limits. Improper equipment operations can lead to defects that are collateral results of operational practices. Procedural compliance and operator training are two primary mechanisms used to limit operational errors that can result in equipment failure and the necessity for

repairs. Finally defects will naturally build up as a result of the cumulative run time of the machinery or systems in the submarine. The amount of time that the ship's systems are operated is largely determined by operational schedules and larger operational needs.

Planned maintenance requirements are generated by the manufacturers and Navy system designers based on the requirements of the technical manuals and operational experience. The Navy utilizes the Maintenance and Material Management (3M) system to set forth scheduling and execution requirements for the PMS program. Planned maintenance requirement cards (MRC), generated for each major PMS task, list the required (or potentially required) parts, tools, and equipment that must be used for the work. Planned maintenance includes preventive (time based) work, e.g. replace worn parts on a pump if vibration exceeds a certain tolerance, as well as general measurements and inspections that must be performed on a specific component or piece of equipment. Some PMS tasks are situational in nature and are not firmly scheduled. These tasks may be performed when a certain operational limit is reached or a certain amount of cumulative run time is met for a component or system, e.g. clean and inspect the air filter every 200 hours of operation or when differential pressure exceeds 0.5 pounds.

PMS requirements are scheduled in various ways depending on the specific time scope in question. The broadest form of PMS scheduling is the cyclic PMS schedule. The cyclic schedule contains all the major PMS tasks that have periodicities greater than or equal to one year and cover a period from the end of the ships last major overhaul until its next scheduled major overhaul. From the cyclic schedule quarterly and weekly schedules are developed that contain the more frequently performed PMS tasks. The individual submarine typically schedules PMS requirements based on a general knowledge of the ships operational schedule for the upcoming year. Major PMS items are scheduled during in port periods since they typically require the affected system to be shut down.

The total demand for repair parts necessary to meet PMS requirements for the submarine force can therefore be articulated as having a variable and fixed portion. The total fixed repair parts demand is a function of the normal execution of the PMS schedules on all the ships. The demand for repair parts from this source would not be expected to vary significantly as a function of how much the equipment was operated. The other demand for repair parts from the PMS system can be attributed to the level of operations. Since some PMS requirements are situational (typically based on wear measurements) than additional operational activity will increase the demand for repair parts to meet situational needs.

Defects that are not identified by the PMS system can manifest themselves in system or component failures. In the event of a system or component failure corrective repairs are necessary. Repair parts that are necessary to perform these repairs are supplied from the ship's on board stock if available or ordered from the supply system as necessary. The total demand for repair parts necessary to perform corrective repairs varies by the nature of the repair and the specific system in question. However the rate at which equipment, if operated properly, is susceptible to failure or breakdown can be attributed to the inherent rate at which defects build up in the system as discussed previously.

As PMS or repairs are conducted the total level of equipment defects on the ship are reduced and thereby acts to balance the growth in demand for additional repair parts above base levels of the PMS schedules. PMS and repairs both can require the securing of ships systems and equipment that may be necessary to meet operational requirements. The PMS requirements that form the base PMS schedules represent a balance between the performance of excessive PMS (to minimize equipment defects) and the performance of excessive repairs due to breakdowns that may occur. The following figure depicts the basic causal structure of repair parts demand and includes the stock and flow arrangement for the parts demand and defect elimination processes.

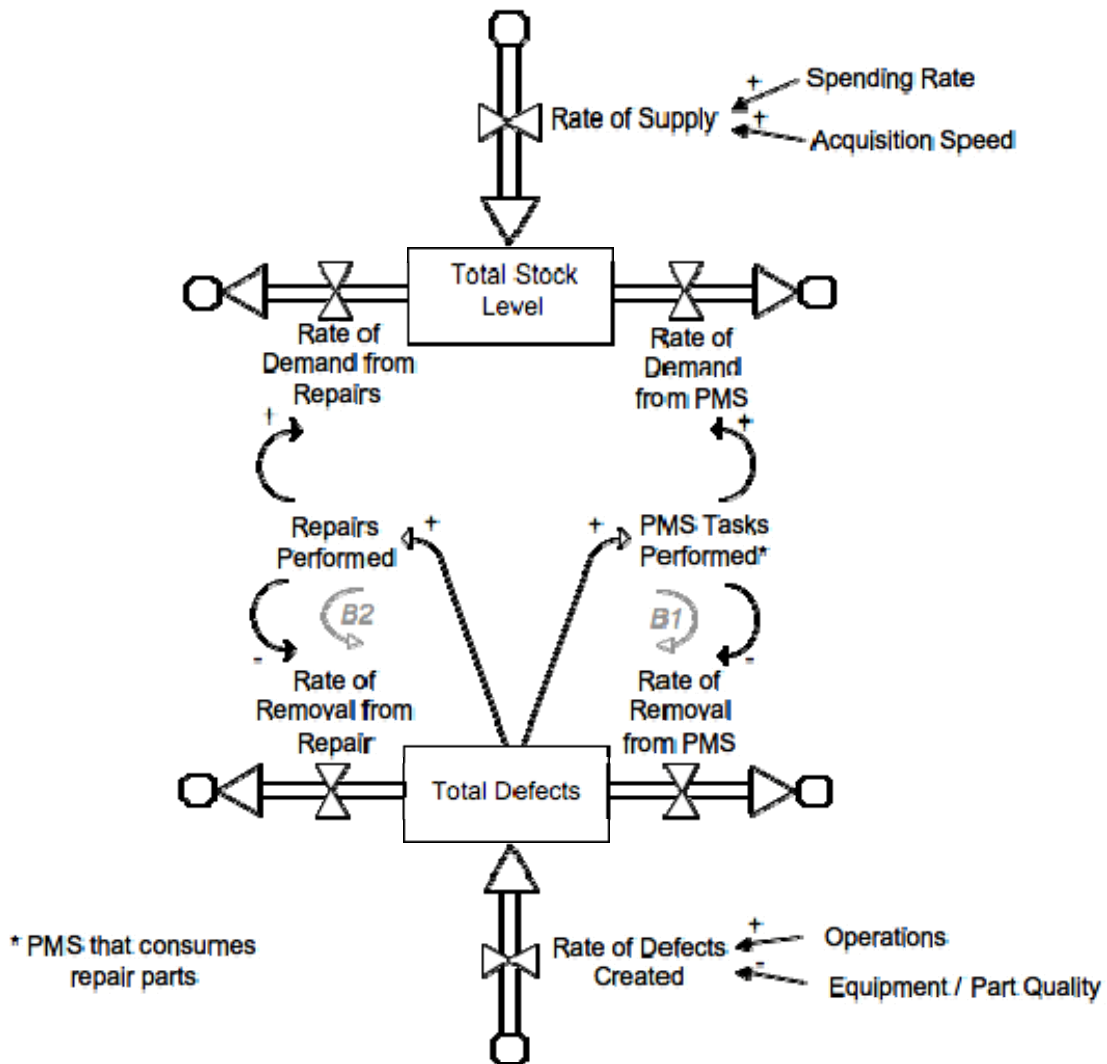

Figure 2. Defect Generation / Removal and Stock Level Structure

In the stock and flow arrangement above there are two main sources. The first source consists of the introduction of new repair parts into the supply system to maintain desired inventory levels. It is a function of the overall spending rate on repair parts and the speed at which they are acquired into the system. As PMS tasks (that consumes repair parts) and repairs are performed the demand for repair parts will grow and the rate of removal of repair parts from stock levels will increase. Since the supply of repair parts into the system is limited by the

spending rate and the acquisition speed the supply of parts will exhibit a material delay of the first order. More will be discussed with respect to the acquisition delay in the next section.

The amount of PMS tasks and repairs performed are modeled in this figure as being caused by the total defects present in the force in all of the systems used. The rate at which defects are created is the second “supply” in this figure. Two main factors that affect the rate of defects being generated in the submarines are the operations pattern (tempo and quality) and the material designs (equipment / part quality). Defects will be removed by the PMS or repair processes and the rate at which the removal occurs is a function of the amount of repairs or PMS accomplished. Therefore two balancing loops, B1 and B2, are established to show the beneficial effects on defect reduction that both maintenance processes have. Another factor that affects the amount of defect elimination and creation is the quality and productivity of the work efforts. Higher quality and productivity of PMS may lead to better identification of potential failures and thus eliminate more defects prior to the failure point. Higher quality of repairs may ensure that the equipment is restored to 100 percent defect free capacity and thus lengthen the time between major breakdowns. For simplicity the effects of quality and productivity of the maintenance processes was not included. The next section will focus on the supply chain management of the repair parts within a budgetary and spending limit context.

## **B. REPAIR PARTS SUPPLY CHAIN MANAGEMENT**

In order to fulfill the demand requirements generated by the operations, PMS, and repair processes supply managers at all levels of the submarine force and Navy must perform effective supply chain management. This section develops a basic causal model and stock and flow arrangement of the force level generic stock management structure. The stock management structure in many supply chains exhibits one of the fundamental systems behaviors, amplification, that will also be discussed below.

Navy supply managers in the submarine force have as inputs to their decision logic both quantity / rate of incoming orders for new repair parts as well as the level and rate of change of their inventory levels. From these parameters it is possible to project both the rate at which new parts will arrive and the rate at which inventory levels will change over time. Time delay exists from the time the orders are placed for replacements to inventory and the time they arrive from the supplier. This supply line delay varies dependent on the type and quantities of the parts ordered as well as the frequency at which orders are necessary to fulfill demand for that part. The time of delay in the acquisition must also be adjusted for when determining the desired acquisition rate of new parts.

As discussed previously the order rate of new parts is a function of the total demand for parts necessary to accomplish both planned maintenance and repairs. In addition to the demand requirements budgetary constraints such as spending ceilings (imposed by law) must be considered as well as the need to hold funds in reserve to meet contingent requirements. The amount of money allowed to be spent, better known as budget authority, is a function of the budget outcome and the subsequent allotment amount to the submarine force repair OPTAR account from the larger Navy O&M appropriation. New budget authority typically coincides with the passing of the Department of Defense (DoD) Appropriations Act on or around 30 September of each year. More will be discussed on the specific budgeting process in the next section.

Sterman provides a basic stock and flow arrangement with the causal links associated with the typical stock management process.<sup>11</sup> The following diagram represents the Sterman supply chain management model causal diagram with a slight modification made with the order rate adjustment. With the submarine OPTAR process the order rates are constrained by real spending limits. This provides for another adjustment to the indicated order rate so that spending does not exceed available budget authority levels.

---

<sup>11</sup> Sterman, 2000, p. 676.

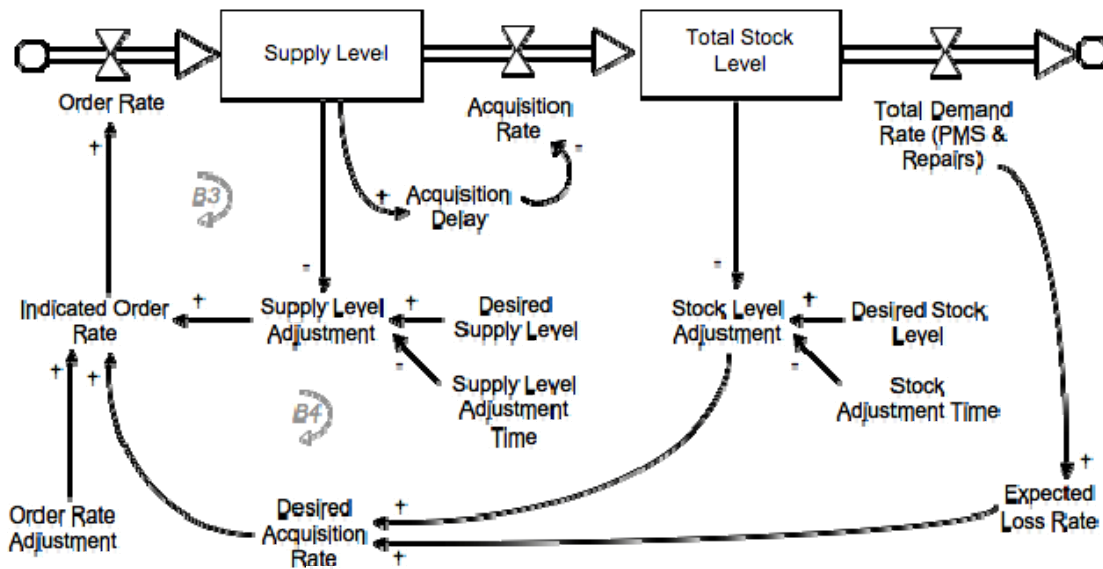

Figure 3. Repair Parts Supply Chain Management Process

Within the supply chain management process illustrated above it can be seen that the basic mechanics of the process are modeled. The expected loss rate of repair parts from stock (inventory) is based on the total demand for parts. This information is coupled with the knowledge of actual and desired stock levels to make an adjustment to the desired acquisition rate. The amount of repair parts in the process of being delivered into stock form the supply level. An adjustment to the order rate is also made based on current amounts of orders already in the supply system but not yet delivered into stock.

Two balancing loops exist in the typical supply chain process depicted above. The adjustment to supply and stock levels will act to balance or limit the rate of growth of orders in the system. A material delay (acquisition delay) from the time the parts are ordered until they arrive in the stock system will limit how fast the acquisition rate can change relative to the order rate or supply level in the system. The balancing loops for supply and stock levels are labeled as B3 and B4 respectively. One exogenous variable provides an additional adjustment to the final order rate and is a function budget and spending allowance processes. This process is the focus of the next section.

### **C. BUDGET AND SPENDING PLAN PROCESSES**

The final outcome of the repair OPTAR process results in the obligation of funds from current budget authority when orders are placed for new repair parts. The rate at which funds are obligated is governed by both the demand for repair parts and the limits on budget authority that may constrain the total spending behavior. Spending that exceeds budget authority would be a violation of public law (Anti-deficiency Act) and is prohibited except for specific unforeseen obligations of an emergent nature. To allow for unforeseen (contingent) requirements the entire budget authority provided by the DoD Appropriations Act is not necessarily distributed fully to all tenant commands within each service. Of the allotment amount the submarine force receives each year the respective Type Commanders set operational spending targets to both ensure effective execution of the budget authority provided each year and to allow for flexibility with the expenditure of funds in the event of contingencies.<sup>12</sup>

Within 10 days of the passing of the DoD Appropriations Act or continuing resolution the DoD typically determines the allotment levels to be provided to all tenant agencies to execute their budget requirements. The Navy in turn allocated specific budget authority levels to the submarine force type commanders who sub-allocate these funds in turn to the various budget submitting offices that are subordinate to the Type Commander. Allotments are provided to the budget submitting offices on a quarterly basis. OPTAR obligation rate targets are typically set at or about 8% per month of the budget authority of the quarter.<sup>13</sup> This budget authority allows for all spending components to incur obligations to order new repair parts or other expenses associated with repairable equipment.

As repairs or planned maintenance consume repair parts the rate at which parts are ordered determine the obligation rate of the OPTAR budget authority.

---

<sup>12</sup> COMSUBLANT / COMSUBPAC Instruction 7330.5A, p. 2-1.

<sup>13</sup> Ibid., p. 2-22.

Commands can adjust the rate at which repair parts OPTAR is obligated accordingly to stay within target obligation rates. At the end of each fiscal month all commands that exercise budget authority submit a Budget OPTAR Report (BOR). The BOR contains the record of execution of the current budget authority in all spending categories including repair parts OPTAR. This report provides a periodic update to operational commanders and financial planners on the status of budget execution.

Since each spending activity within the submarine force could potentially obligate funds based on very different needs a planning process exists that identifies the baseline spending requirements for each spending activity. Early in the planning phase of the next budget year estimates are provided to the submarine force on the expected budget authority amounts. These estimates form the expected ceiling or upper limit to total budget authority expected in the DoD Appropriations Act for each funding area. The Type Commanders take these estimates, along with the Annual Financial Plans (AFP) provided to them from all subordinate spending activities and align resources to requirements. The result of this process is the approved AFPs that outline the expected spending requirements for each tenant command under the Type Commander for the upcoming fiscal year. Approximately 8% of this AFP level is the target obligation rate for that specific spending component.

Annual Financial Plans form the basis by which spending, in the form of obligations from budget authority, are controlled by the Type Commander. Projections about future resource needs utilize both historical budget experience from the execution of previous financial plans as well as projections about future resource requirements and operational schedules. The Navy office of Financial Management and Budget (FMB), also known as OPNAV N82, is charged the responsibility to assess budget inputs and determine resource allocations to the various Navy components that go into the budget submittal for future budget periods.

For the submarine force repair OPTAR projections are based upon a combination of a 3-year historical average of expenditure levels as well as an adjustment for projected price growth in the upcoming fiscal period and actual price growth observed in the previous two execution periods. A projection of the current execution year spending is required since the future year budget (or change proposal in the odd years) is submitted to Congress approximately 7 months before the end of the current execution year. Included in the historical and projected expenditure levels is a record of the amount of adjustments into and out of the repair OPTAR account that were made throughout the execution period in question. Adjustments, which are the results of transfer, re-programming, or supplemental funding, are made periodically during the execution year as warranted by changes to operational or fiscal plans.

Adjustments to budget authority amounts in the repair OPTAR accounts typically occur after a review of the execution of the budget over some period. A formal mid year review of the budget execution occurs at all levels with the submarine force and Navy and major adjustments can be made at that time. This review is typically completed in the June to July time frame at or about the half-way point in the execution period. Adjustments to current year account levels are therefore made after the future year budget figures have been submitted to Congress for authorization and appropriation.

The following figure represents a summary of the overall spending and budget projection process associated with the repair OPTAR budget authority. This process results in the formulation of spending targets that ultimately control or influence the order rate of repair parts in the supply chain management system. In the figure there are three causal loops that represent three primary processes at work in the execution control and budgeting system. The first one is a re-enforcing loop R1 that demonstrates the basic process in which higher obligation rates provide positive feedback in the budgeting process that results in higher future budget requests. The level and trend in obligations provides one of two inputs into the decision logic to adjust future budget amounts. The second

re-enforcing loop R2 demonstrates the effects of backlog orders on the decision logic for future budget amounts. The level and trends in the backlogs in orders, as measured as the difference between indicated and actual orders, affect the amount of future budget adjustments.

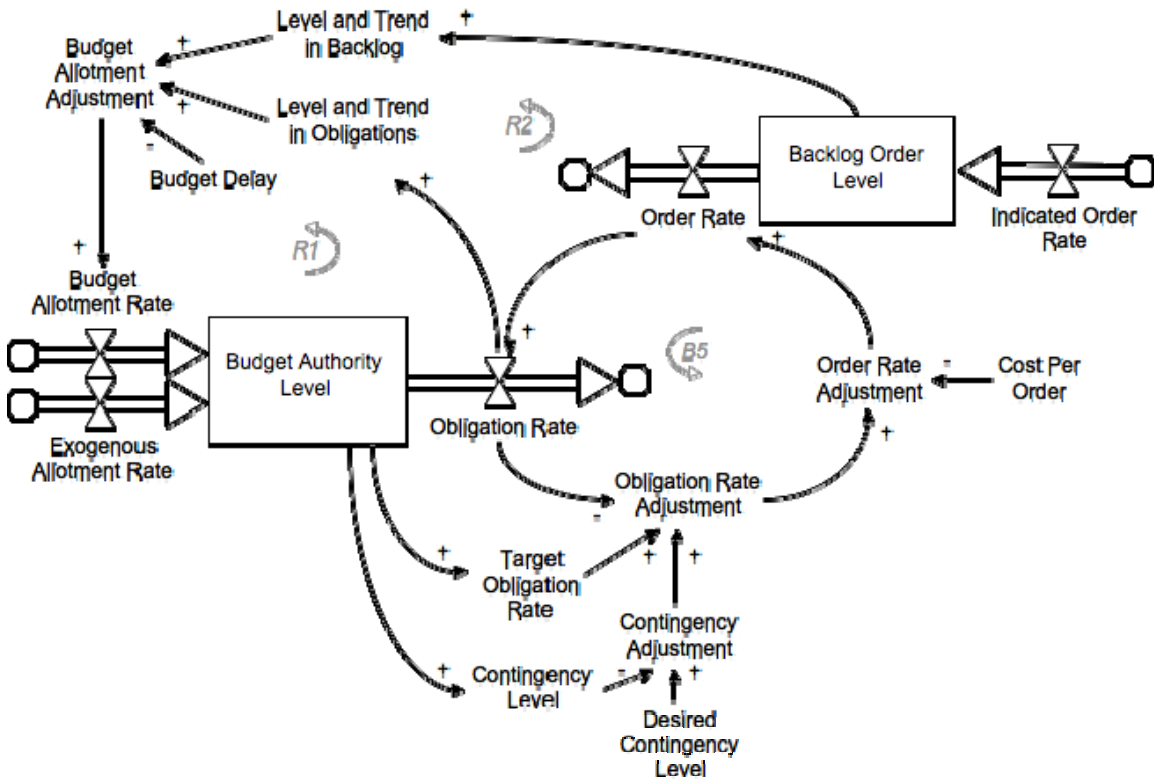

Figure 4. Budget Adjustment and Obligation Target Process

The final causal loop in the process is balancing loop B5. This loop represents the effect of spending control over the budget execution period. Total obligations cannot exceed the current legal limits as specified in the allotment (budget authority) amounts given to the submarine force. As obligations are incurred they are compared to planned rates of spending and order rates can be adjusted to stay within limits. Also modeled in this process is the 'contingency' effect where a portion of the total budget authority is set aside and spending rates adjusted to keep or maintain this contingency level. At the end of the fiscal

period this contingency level can be obligated since new budget authority will be received for the next fiscal period and the need to maintain contingency funding in this period is no longer warranted. Therefore the desired contingency level is a function of the time within the current execution period and this parameter sets the reference condition for contingency adjustments to spending rates.

The cost per order also affects the order rate because given a specific obligation target as the cost of orders (or repair parts per order) goes up the amount of orders that can be placed decreases. As the order rate drops so does the obligation rates until target levels are reached. Finally included in this portion of the model is an exogenous source of supply funds into the total OPTAR budget authority. The amount or frequency of this source of funds is variable and can occur in many forms. Transfers from other budget functions within the Operations and Maintenance (O&M) account, re-programming of funds from a different account, or supplemental funding outside of the budget process all represent exogenous insertions in this regard. The level and trend in this funding source are partially based on the level and trends that affect the normal budget adjustment process; backlogs and obligation history. However the decision to request exogenous corrections to the budget authority levels fundamentally represents a decision to acquire additional funding to meet current year needs. The process that results in corrections to current execution year budget authority also affect future year budget decisions along with backlog and obligation history. However the cause and effect relationship is adequately modeled without creating an additional link between the exogenous input and the budget adjustment.

The next chapter provides a discussion of how the causal model developed in this section was programmed into the Stella ® software and the development of the modeling equations and logical statements used to demonstrate the causal behaviors.

## V. MODEL DEVELOPMENT IN THE STELLA® SOFTWARE

The Stella® software is a common product used by to develop dynamic simulation and system models. The program can create a graphical representation of the stock, flow, and converter arrangement. A stock in this context is essentially a reservoir of either defects, repair parts, or money and the level at any specific point in time is the net effect of demands (or drains) and supplies (or fills) from the stock component. A flow represents a rate of demand or supply to an individual stock. Several different flows can either contribute or take away from the overall level of any individual stock. It is the primary function of the Stella ® software to determine the net effect on the stock by solving the several differential equations at work. Each flow can be a constant or a time series function in it's own right adding to the potential complexity of the overall level change. The stock therefore represents the time series solution to the differential equations of the stocks. A generic example of a basic stock and flow process is illustrated below:

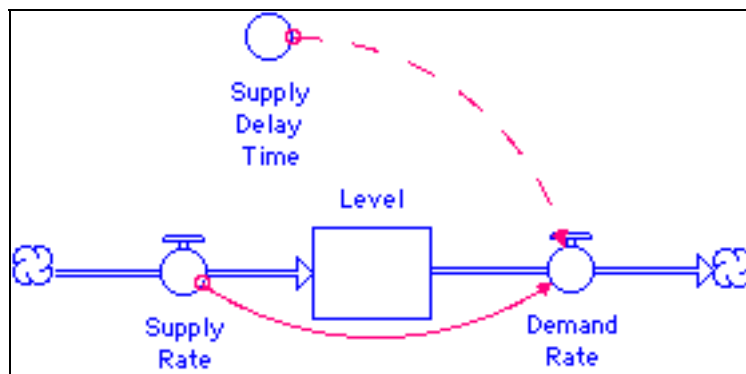

Figure 5. Basic Stella Stock and Flow Model

In this model the supply rate is determined by both the demand rate and the supply delay time. The supply rate is connected to the demand rate by an action connector arrow (solid red) that denoted a cause and effect direct

relationship. The Supply Delay Time is connected to the demand rate with an information connector (dashed red). The supply rate empties into the level stock and the demand rate drains the level accordingly. The supply rate in this example is a formula that determines the supply rate as after a first order material delay of the supply delay time. The specific modeling equations in this case are:

$$\text{Level}(t) = \text{Level}(t - dt) + (\text{Supply\_Rate} - \text{Demand\_Rate}) * dt$$

$$\text{INIT Level} = 1000$$

$$\text{Supply\_Rate} = 1 * \text{Time}$$

$$\text{Demand\_Rate} = \text{DELAY}(\text{Supply\_Rate}, \text{Supply\_Delay\_Time})$$

$$\text{Supply\_Delay\_Time} = 6$$

This results in the following time series behavior of the example model that shows the level as it changes over time at a rate equivalent to the difference between demand and supply rates over time.

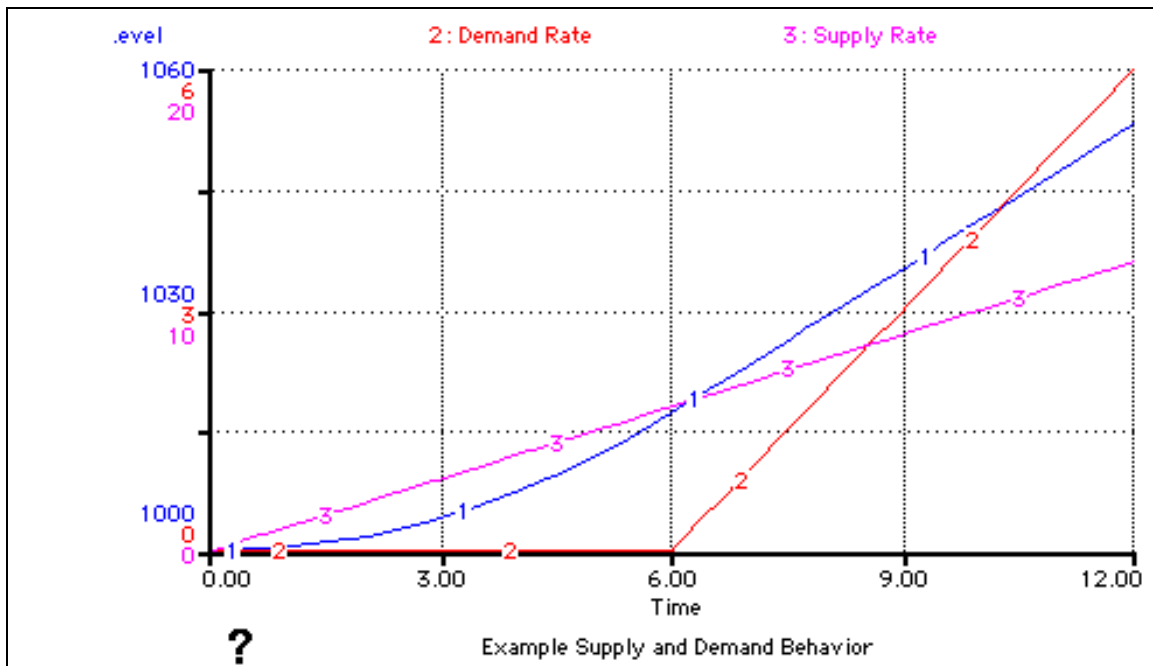

Figure 6. Example Stella Model Printout of System Parameters

Note that in this example the level over time is a complex outcome of two relatively simple supply and demand rates that change over time. Stella has the ability to view, graph, and modify any of the parameters in the system with either built in functions or through creation of custom functions by the user. In this example the built in function DELAY was used to provide the material delay between supply and demand rates and the supply rate, demand rate, and level were plotted. The output graph shown above is scaled with three different axes but can be modified to show all data in the relative scale to each other.

For the submarine OPTAR process the model was divided into sub-models that each perform a basic processes of the system. The individual sub-models are discussed in more detail below. The specific modeling equations for each sub model are provided in the Appendix.

#### **A. DEFECT GENERATION AND REPAIR PARTS DEMAND**

As discussed in the last chapter the demand for repair parts is determined both by planned and unplanned maintenance requirements. Repair parts can be ordered for two basic reasons in this model. First parts can be ordered as the result of equipment breakdown requiring repair. Planned maintenance (PMS) represents a pre-emptive attempt to identify and replace potentially breakdown-causing defects before the actual equipment breakdown occurs. Any defective parts found during the performance of planned maintenance would also require potential replacement and the ordering of repair parts. In addition consumable type items (brushes, gaskets, etc.) may also be replaced during planned maintenance based on the relative condition and wear characteristics of these consumable type parts. Ultimately breakdowns occur when the amount of defects in a system build up, without removal, to some threshold point. The performance of PMS and Repairs act to lower the total defects present in the system at any given time. The defect generation and repair parts demand sub-model is illustrated as a basic stock and flow model below.

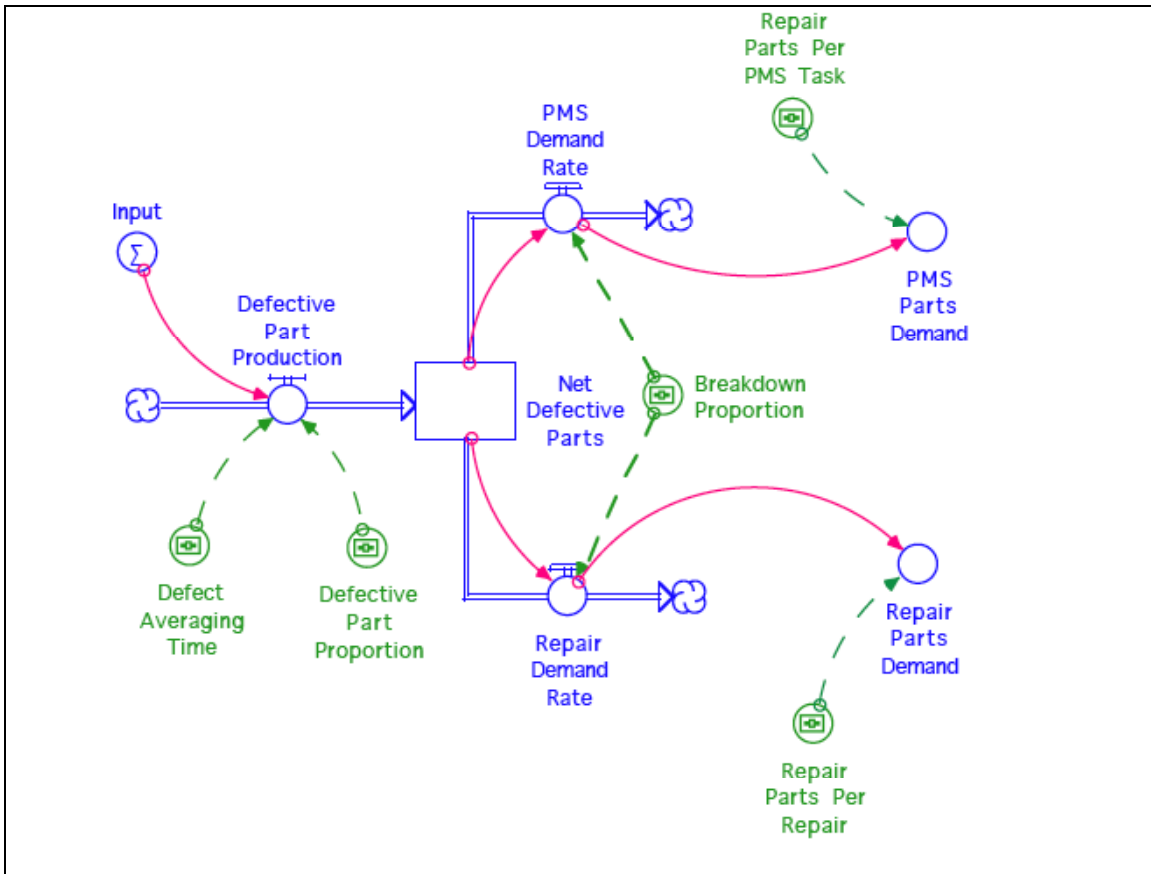

Figure 7. Defect Generation and Repair Parts Demand Sub-model

In this sub-model the creation of defective parts is developed as a direct function of the operations tempo (OPTEMPO) level. OPTEMPO is a general measure of overall submarine activity and is typically denoted in equivalent ship-years or ship months of continuous operation. For this model OPTEMPO was given a normal value of 100 and could be varied to control the overall rate of defect production. The OPTEMPO level can be a constant, a function, or a combination of both over time. As OPTEMPO changes in this model the rate at which defective parts are produced will change. A natural rate of buildup and decay was modeled to provide a more realistic change in the creation of defective parts. The specific time to buildup or decay can be adjusted by changing the effect averaging time constant. For this model it was assumed that a six-month averaging time would be sufficient to illustrate the buildup and decay

characteristics of defects. In addition to the natural buildup and decay of defects the defective part production is also represented by a normally distributed defect generation rate around the average value that is based on OPTEMPO. This was done to put some natural variability in to the defect creation process.

Planned maintenance and repair are the two means by which defects can be removed from the system. The PMS demand rate and repair demand rate represent the balance between preventive and corrective maintenance in the system as governed by the breakdown proportion. Too much PMS tasking will lead to excessive take down of equipment and would be cost prohibitive for long periods. If the PMS demand rate is set too low then the net defective parts will build up in the system and increase the chance of a breakdown thus increasing the repair demand rate. Both the PMS demand rate and repair demand rates are functions of the desired breakdown proportion and in this model were set such that 90 percent of the net defective parts would be removed at any OPTEMPO level by PMS. Repairs would remove the remaining 10 percent.

The PMS and repair demand rates are in essence the rate at which these tasks are performed over time. The amount of repair parts required for each PMS task or repair can vary on the specific job at hand but can be represented by an overall average part per task function for both repair and PMS. Therefore the PMS and repair parts demand rates can be adjusted to any level. In the model defaults it was assumed that the amount of parts required for a corrective repair following a breakdown was relatively large compared to the amount of parts required for routine or contingent planned maintenance. The following figures represent the basic behavior of this sub-model for a 10 percent step rise in OPTEMPO level at time=0.

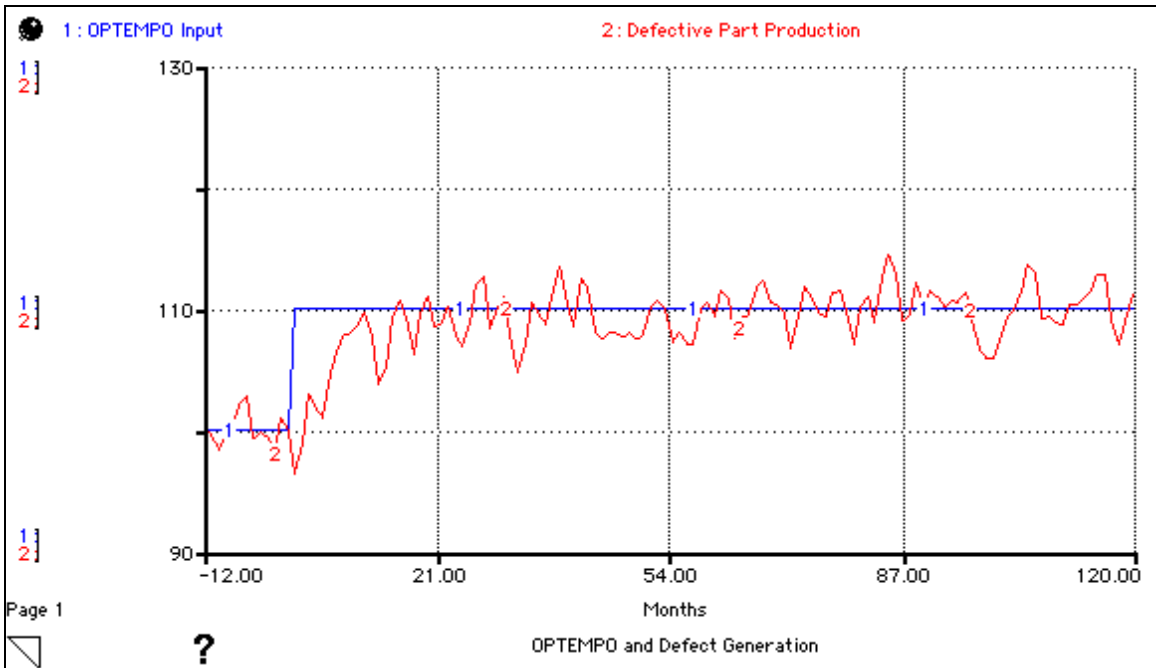

Figure 8. Defect Generation Response to a 10% Rise in OPTEMPO

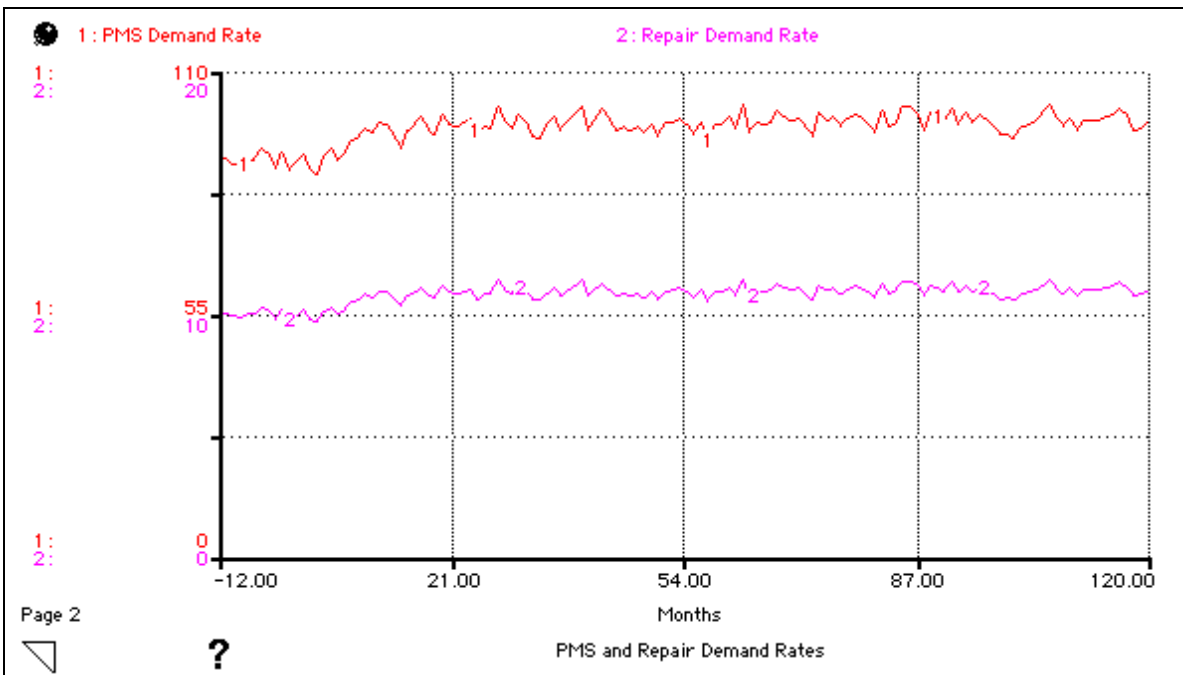

Figure 9. PMS and Repair Demand Rate Response to OPTEMPO Rise

## B. SUPPLY CHAIN MANAGEMENT

A generic supply chain process was utilized to create the supply chain management sub-model.<sup>14</sup> In this model, the supply chain manager must consider the current demand for repair parts as well as the stock inventory level and the outstanding orders not yet delivered into stock when making a decision about adjusting the order rate. The order rate chosen based on all the supply chain inputs forms the basis by which future budget requests are generated. The supply chain management sub-model is illustrated below.

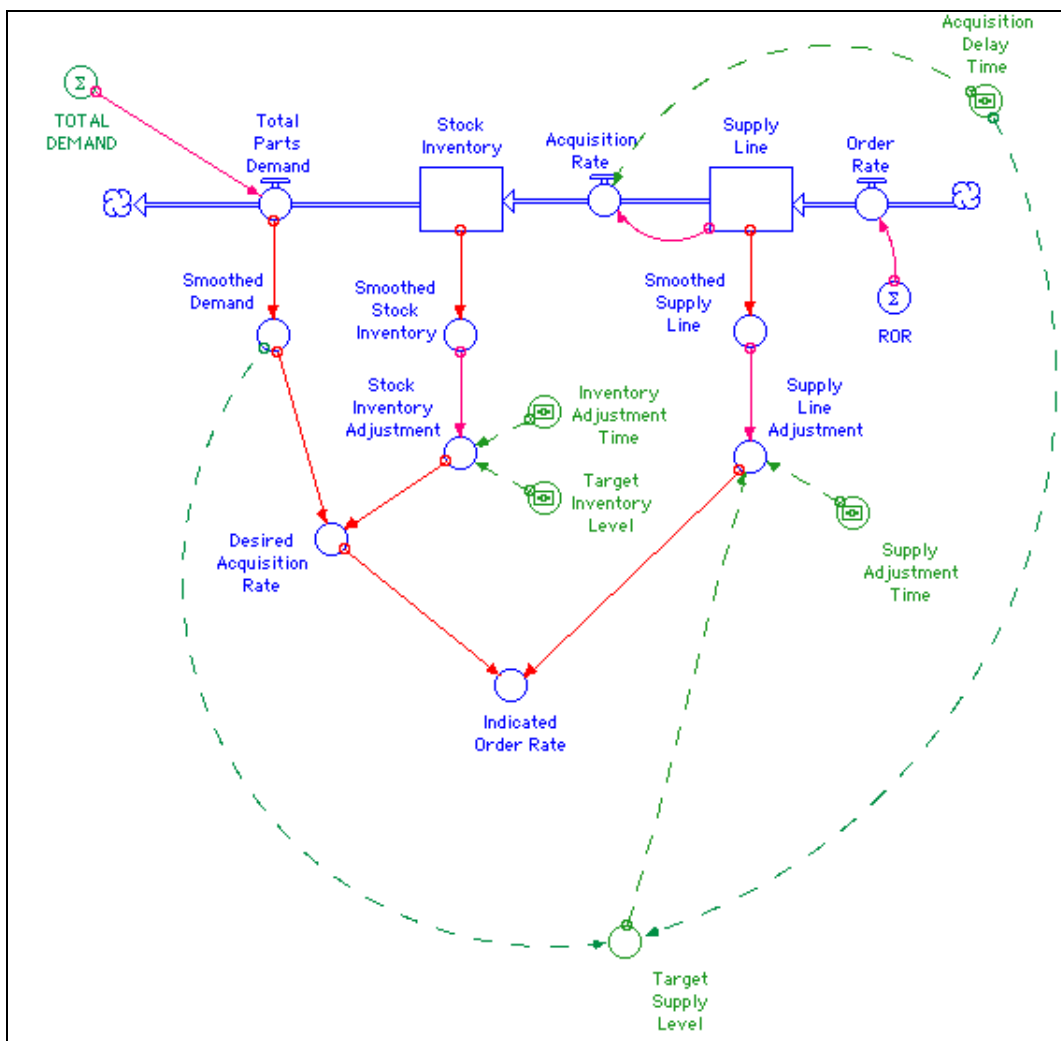

Figure 10. Supply Chain Management Sub-Model

<sup>14</sup> Sterman, 2000 pp. 676, 724.

Incoming demand from the demand sub-model affects the total demand rate for repair parts. To fulfill orders parts are drawn from the stock inventory causing the level to fall. The changes in both inventory level and total demand fluctuate based on the normal variation in demand. To assess a better overall trend or change in level supply chain managers typically average the levels over time.<sup>15</sup> This is represented in the sub-model as the smoothed demand and smoothed stock inventory converters. From the smoothed demand and inventory levels a desired acquisition rate is developed that captures the ordering rate that would be performed to replenish inventory to target levels and meet current demand without consideration of the orders already placed.

Replenishment to stock inventory levels is accomplished when orders that were placed arrive from the supply line and are acquired into inventory. The rate at which inventory replacement parts are acquired is a function of both the current orders outstanding in the supply line and the average acquisition delay time. When considering the overall orders to be placed the supply line manager must also consider these outstanding orders not yet acquired. The level of parts in the supply line also exhibits volatility because of the variation in demand and must be smoothed out to form an average interpretation of outstanding orders not yet acquired. The supply line adjustment to the desired acquisition rate results in the indicated order rate. The indicated order rate represents the most rational order rate possible given all the information in the supply chain. Both the information quality (accuracy) and the relative weight given to the various supply chain components also affect the indicated order rate. Several experiments have shown that there is a strong tendency to put less weight in the supply line than the other components in the supply chain.<sup>16</sup> For this sub-model, the current demand was given 100 percent weight, the inventory 90 percent, and the supply chain 60 percent relative weight respectively.

---

<sup>15</sup> Sterman, 1989a, b; Diehl and Sterman, 1995.

<sup>16</sup> Brehmer, 1992.

In a typical supply chain process the supply manager would be considered in controlling both the total inventory level and the supply line orders outstanding to ensure that over and under ordering were minimized. Target levels for both the supply line and inventory would be set based on experience and the ability to meet current and forecast needs. For this model only the total inventory level is controlled to a target and the supply line is not directly controlled to a target level. This is a reflection of the fact that supply is not an internally controlled function of the submarine force. The supply line therefore can assume any non-negative value based on the previous order history.

Provided below is the sub-models typical response to a 10 percent rise in demand (as determined by OPTEMPO). The target inventory level is set to a level that was relatively large when compared to the demand level. The input parameters to the indicated order rate were smoothed with an averaging time of three months. A six month inventory correction period was chosen to reflect a realistic timeline to restore inventory to target levels. In order to illustrate the isolated effects of this sub-model alone the order rate was set equal to the indicated order rate. This in essence ignores any form of fiscal constraints or fiscal controls that may be in place as the results of budget levels.

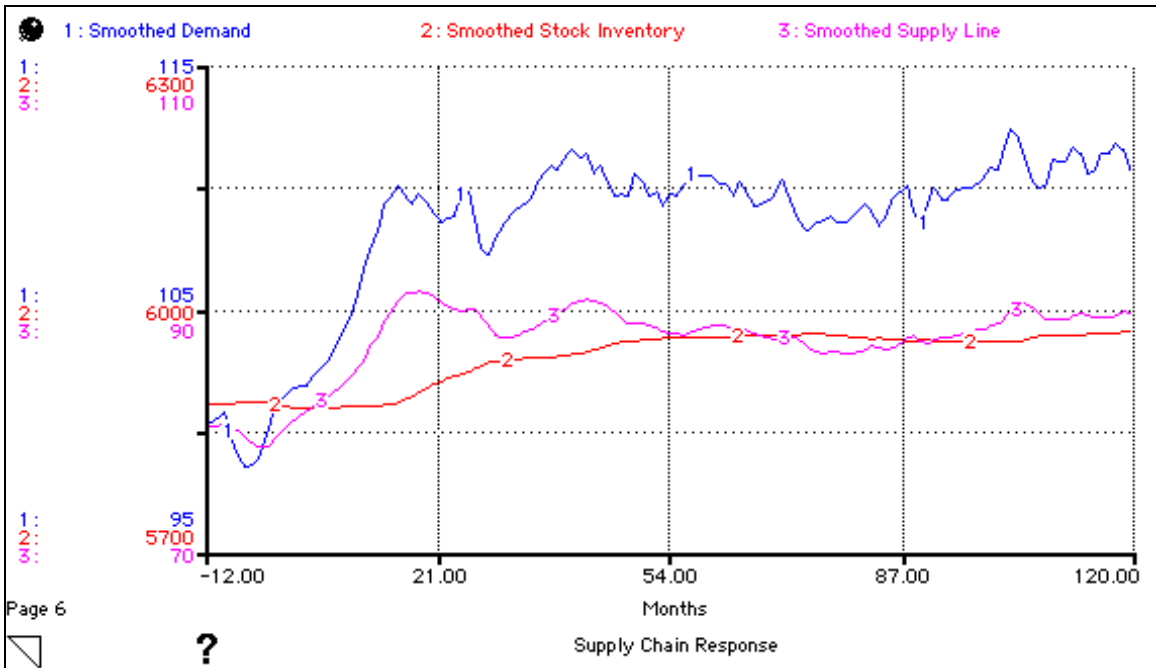

Figure 11. Supply Chain Level Response to 10% Demand Increase

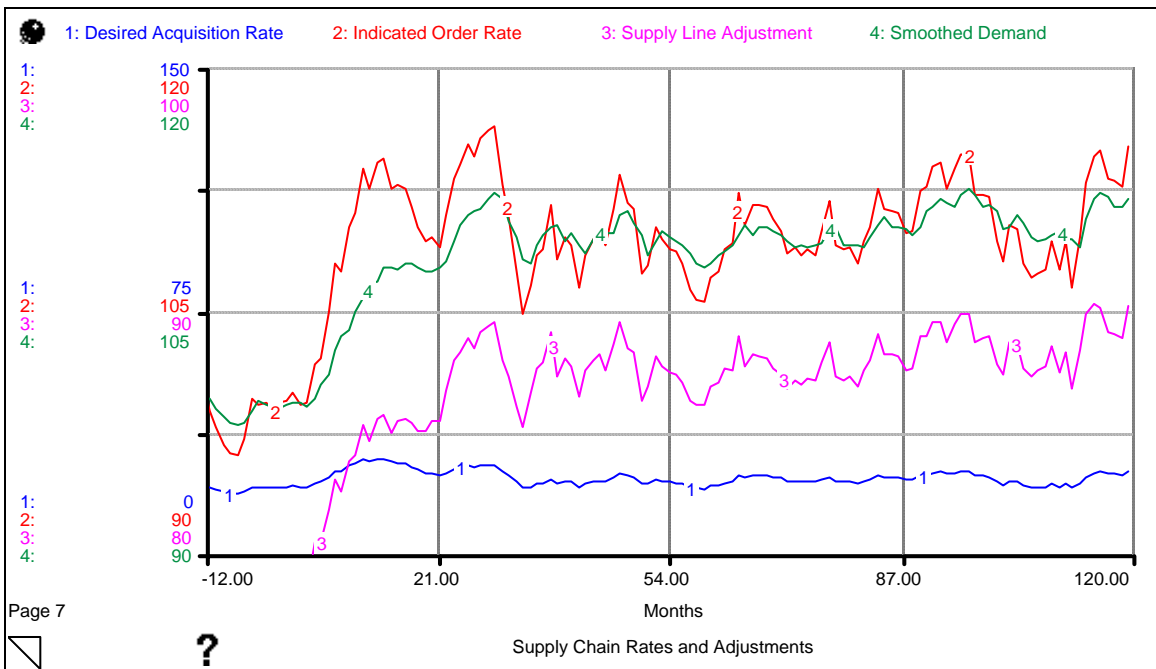

Figure 12. Supply Chain Rate Response to 10% Demand Increase

The two figures above illustrate the very dynamic nature of supply chain management over time even without major adjustments to operating patterns. The supply levels and order rates in Figures 11 and 12 respectively are the best possible outcome the supply chain manager could make if spending was unlimited by fiscal policy and procedure. The next sub-model provides the mechanism whereby demand for parts is converted into annual budget amounts, budget corrections at the mid year point, and target obligation rates that ultimately control short term ordering behavior.

### **C. BUDGET FORMULATION, CORRECTION, AND SPENDING CONTROL**

The next sub-model utilizes information from the supply chain, specifically the indicated order rate, to forecast future budgetary needs. The future year budget amount is based upon an assessment of demand for repair parts, corrected for the supply chain dynamics, and the historical spending level over some pre-determined period of time. Estimation errors, or fact of life differences between predicted and actual demand, can manifest as shortages or surpluses in total budget authority for the execution year. Typically these errors can be address formally at the mid year review of the current execution year. At that time adjustments (positive or negative) can be made to the available budget authority to correct for this error.

In addition to demand the level of order backlog must be considered when projecting future budgetary needs. Backlogs can occur whenever, due to fiscal constraints, orders were not placed. This backlog will accumulate based on the difference between indicated orders and real orders in the system. Once the future budget level is formulated the spending target level is set. When future orders are placed for repair parts this limit must be considered and followed to the maximum extent practicable. Previous studies have shown a tendency to control obligation rates, which in this case is represented by order rates, to target levels when executing monthly O&M obligations.<sup>17</sup> For this model exact

---

<sup>17</sup> Kozar, 1993, p. 135.

compliance with spending was modeled by setting the actual order rate equal to the target order rate determined by the budgeting system. This is a simplification of the actual process but represents the average behavior in the system over time. The following figure depicts the budget execution and control sub-model.

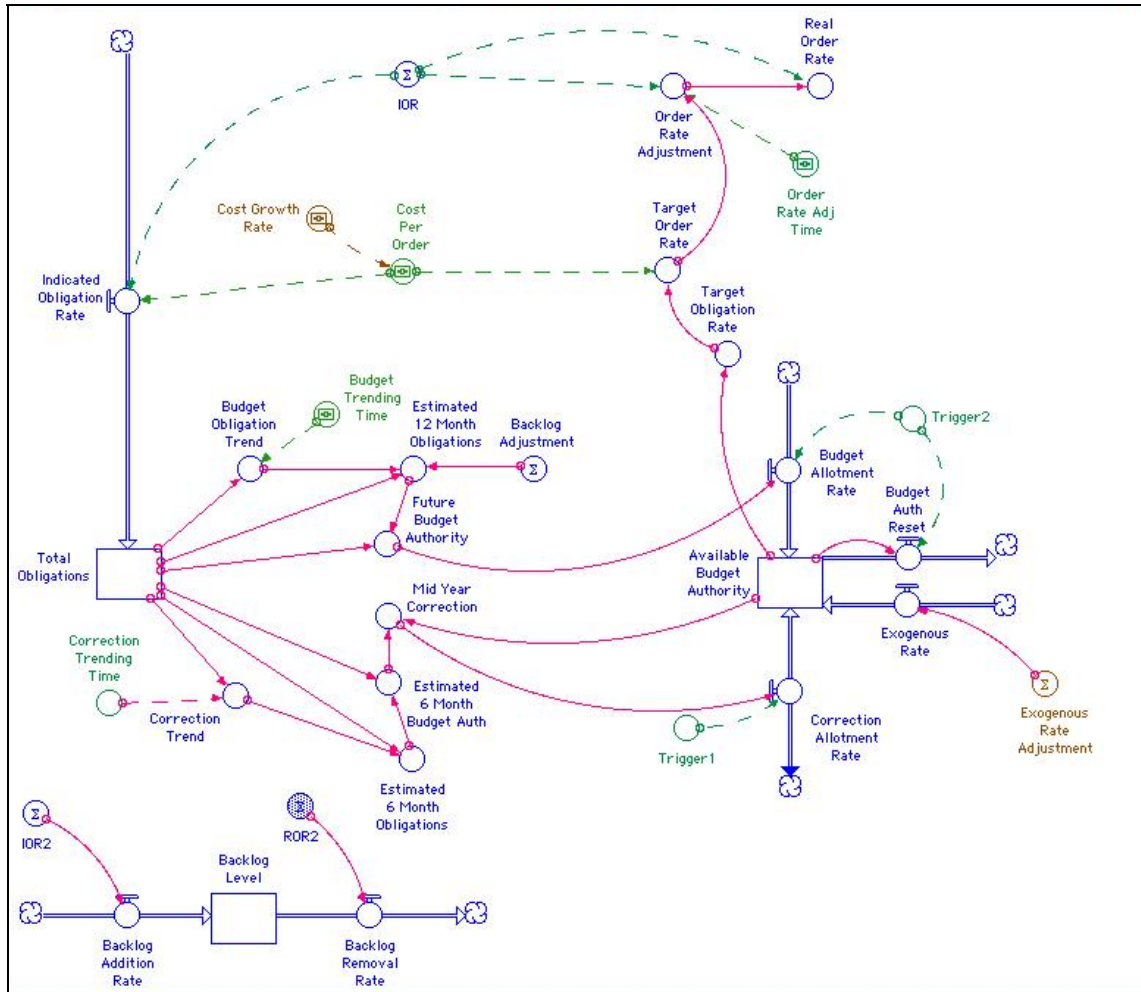

Figure 13. Budget Formulation and Spending Control Sub-Model

In this sub-model the indicated order rate (IOR) from the previous module feeds a total obligation stock. At any given time the current total obligations are the integral of all the order rates incurred since the model was initialized. The trend in this obligation level issued to control two prediction mechanisms. The first is the future year forecast of the base budget amount based on a three-year

historical average of past monthly obligations. In essence this averaging is similar to the method used by the budget programmers with the Ship Operations Model.<sup>18</sup> The budget obligation trend over the last thirty six months is captured in the determined and used to predict the required future obligation level. The amount of backlog that has accrued over the period is also added to the estimated future obligation level at this time. The amount of backlog is determined. The future budget authority converter represents the difference between the forecast budget level and the previous year budget level and is the base budget amount that is sent to the available budget authority at the start of the new budget year.

In second budget forecast mechanism also measures the total obligations over time but only uses the past 6 months of spending history to determine a short term projection of budget needs over the next six months. This represents the mid-year review and correction process to the base budget amount. Obligations that accrue over the first six months of the execution year are used to forecast the remaining execution year requirements and an adjustment amount to the current year budget authority is made. The mid year correction converter represents the overall results of this determination process.

Both of the budget estimate levels will continuously vary over time as the nature of the demand changes. However budget levels, and corrections to them, are not continuous but discreet processes that occur at specific intervals in the budget and execution process. Discreet additions of budget authority by both of the forecast mechanisms are controlled through the budget allotment and correction allotment rates. A trigger signal is used to control when the base budget allotment or correction allotment are step inserted into the available budget authority stock each year. The model default is to insert the budget allotment at the beginning of each model year and the correction allotment is inserted at the six-month point. In addition the correction allotment is not one

---

<sup>18</sup> Hascall et al., pp. 36-38.

way but is a bi-flow system where removals of budget authority, when excess authority exists, can be performed. This in essence could be thought of as a transfer or reprogramming of funds into or out of this budget authority account that are made by higher authority to correct budget error.

At the end of each fiscal year the budget authority, or ability to incur new obligations with this funding, expires. Therefore a budget authority reset flow, controlled on the same trigger signal as the new budget allotment, will empty the budget authority stock and reset it to zero level before the new budget allotment is made. Finally an exogenous allotment mechanism is included so that the effects of controlled insertions of funding into or out of the available budget authority can be made. This is not a natural part of this system but a means to perform experiments on the system from completely exogenous changes to budget amounts.

From the available budget authority stock level the target obligation rate is set. For this model the target obligation rate is just one twelfth of the available budget authority in the budget authority stock. This is adjusted by the cost per order to determine the target order rate. The indicated order rate (IOR) is compared to the target order rate and an adjustment made to the real order rate in order to ensure compliance with target order rate amounts. The amount of time allowed to change order rates to comply with spending targets can also be adjusted by the order rate adj. time control. For the default value the model was set to a one-month order rate adjust time. The following figures depict this sub-model response to a step increase in demand of ten percent. The effects of backlog correction are included in the budget response. In addition no exogenous adjustments or additions to the available budget authority were made.

It can be observed from the model results that the amount of available budget authority can change repeatedly over time. This model has simplified that process by only allowing two correction mechanisms for budget forecast error. The first, backlog correction, will add additional funding to cover backlog orders each year.

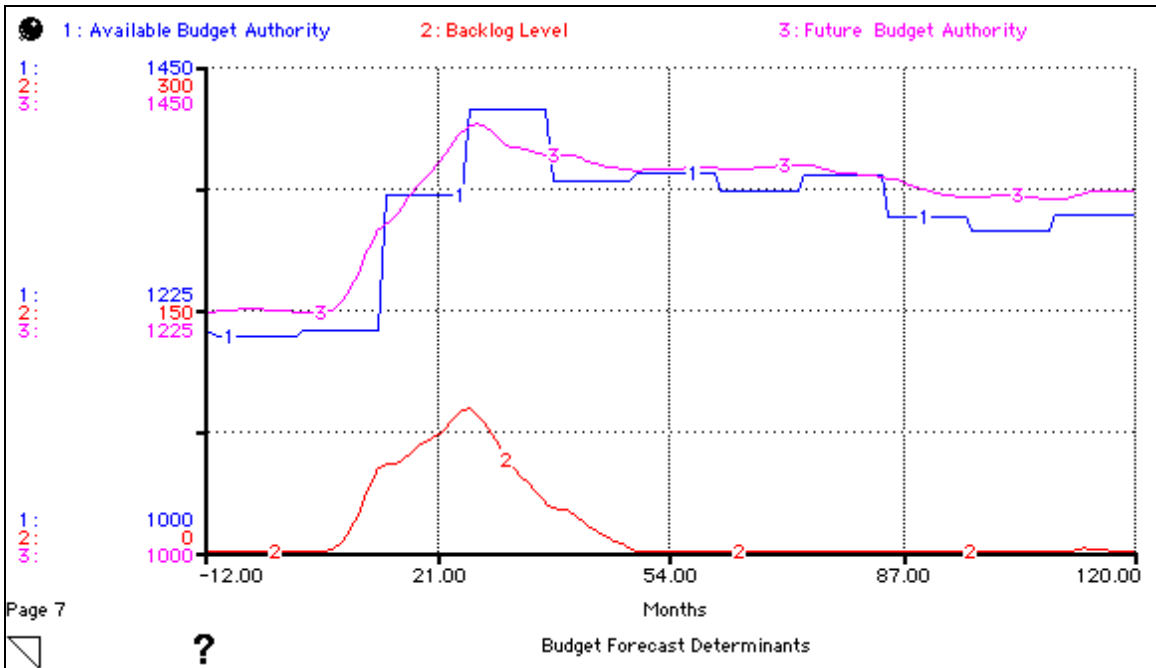

Figure 14. Budget Forecast Components and Backlog Correction to a 10 Percent Demand Increase

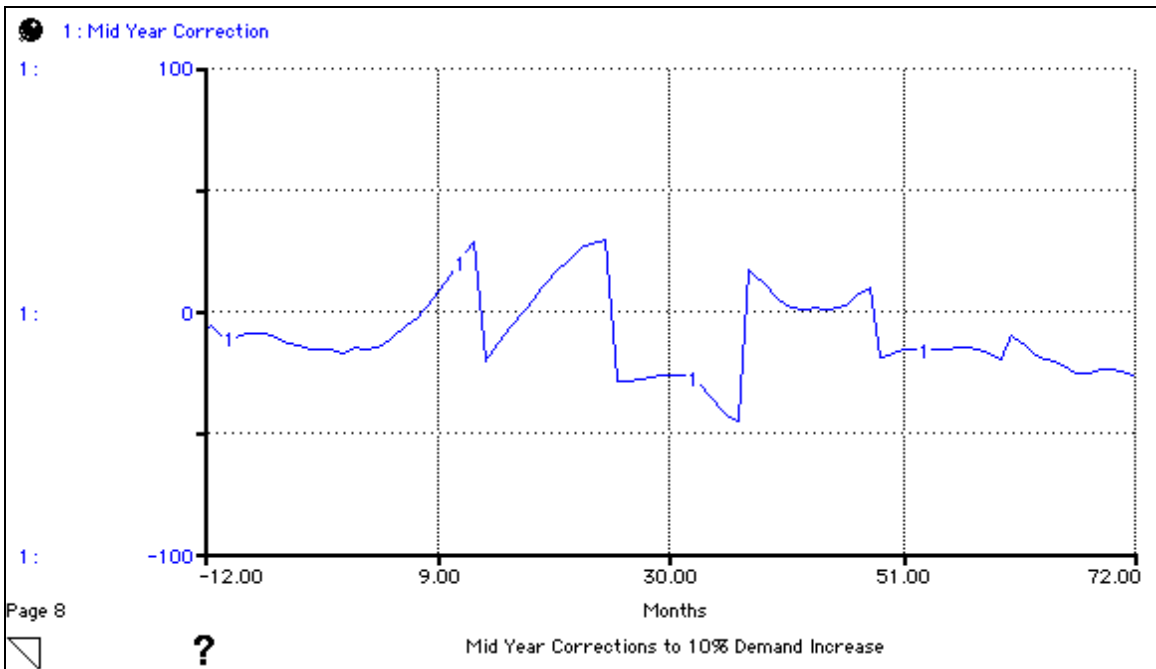

Figure 15. Mid Year Corrections to a 10 Percent Demand Increase

The second is the mid year correction that can insert or remove funding from the budget authority based on short-term trends and projections during the execution year. The result is that the available budget authority changes essentially twice each year in this model. In the real life process several correction processes can take place over the execution year for other reasons than just backlog adjustment and mid year review. However this simplified outlook on the process can effectively demonstrate the overall annual behavior of spending that occurs due to very discreet changes to budget authority that result from adjustments within the execution year.

The next figure represents the indicated and target obligation rates from the model for the same ten percent rise in demand.

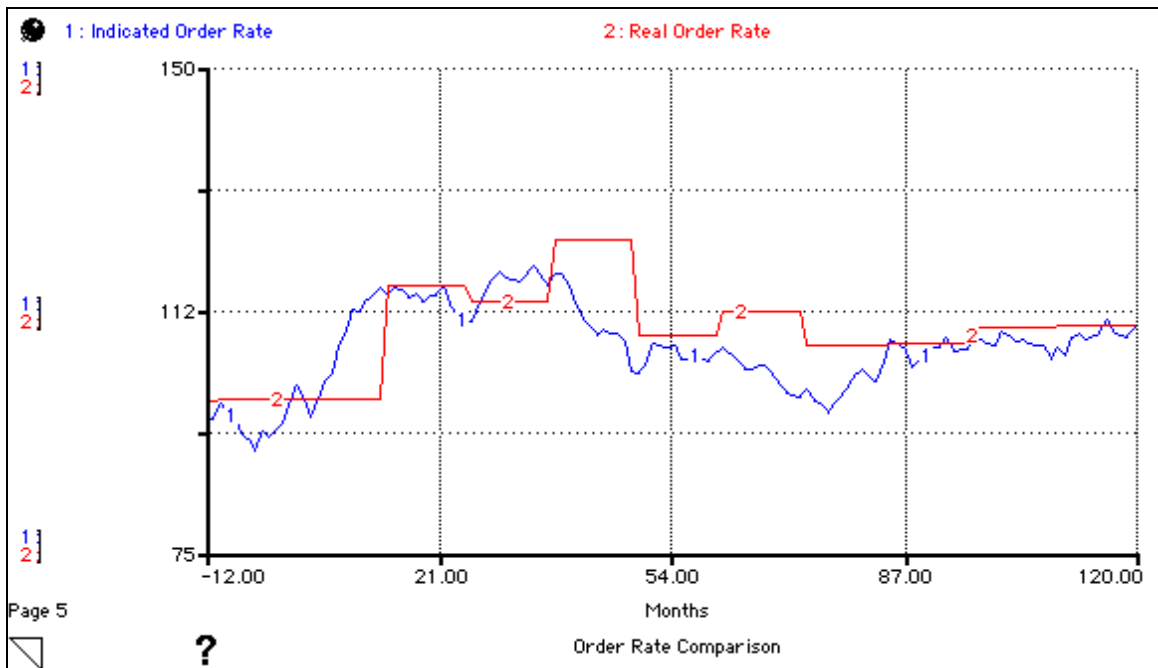

Figure 16. Indicated vs. Real Order Rate for Ten Percent Demand Rise

It can be seen that the model, due to the material delays inherent in the budget and mid year correction processes, cannot respond to changes in the supply chain in real time. The indicated order rate leads the real order rate in the

system response because of the delays incurred while projections, based of measured trends, are made. The mid year correction process helps to offset this delay partially by allowing for a more responsive correction process than the annual budget process can accommodate. The budgeting process, with its thirty-six month trending history, also acts to smooth out the real order rate to be less varied in nature than the indicated order rate over time. In any given year the overall real order rate, and the subsequent total spending in that month, will differ than what the pure demand characteristics of the system would require.

The next chapter will discuss the two fundamental consequences inherent in this system due to the negative feedback loops and delay time. These are oscillation and amplification of the budget response to changes in demand.

THIS PAGE INTENTIONALLY LEFT BLANK

## VI. MODEL SENSITIVITY ANALYSIS

In the previous chapter a dynamic model of the repair OPTAR process was developed using basic system structures that emulate the three basic processes of budgeting, spending controls, and supply chain management. A simple mechanism was developed to generate a time-series demand profile for repair parts in order to evaluate the system response in steady state and transient conditions. A specific example, using the model's default parameters, was illustrated for a step rise in OPTEMPO that in essence resulted in an increase in real demand for repair parts. The model constructed uses a probabilistic demand behavior to illustrate how the system would respond to a real world demand characteristics that were normally distributed around an average demand level that was based on OPTEMPO.

This section performs a more detailed sensitivity analysis of the models transient response when the default assumptions about delay times, smoothing patterns, and trending history are varied. Adjustment of these parameters affects both the supply chain management (a short term effect) and the budget / spending controls behavior (a long term effect). The sensitivity analysis focuses on the following fundamental adjustable parameters of the system:

- The length of time used to smooth out supply chain inputs.
- The length of time to adjust inventory levels back to the target condition.
- The length of historical data utilized in future budget projections.

The primary outcome of this model is a series of budget authority projections based on the transients imposed on the system. Spending targets based on these budget authority projections determine the overall order rates in the system. Therefore the sensitivity analysis primarily looks at changes in budget authority behavior when varying the parameters of the system. The following several sensitivity analyses illustrate the effects on these processes by varying one parameter of the system while holding the others at constant levels.

To produce clearer graphs of the model outputs the probabilistic demand signal was removed. Therefore the model outputs do not show the effects of random demand fluctuations around the larger indicated trends. The effects of random demand fluctuations do affect the overall year-to-year budget outcomes but in essence represent spurious noise around any larger pattern of behavior and do not contribute significantly to the understanding of the global system responses to demand or exogenous funding transients.

#### **A. SENSITIVITY TO SUPPLY CHAIN AVERAGING TIMES**

The first major process in the OPTAR model is the supply chain management system. The overall pattern of future budgets, mid-year corrections, and spending levels are sensitive to two parameters within this system. The supply chain averaging time represents the length of time that supply line information is averaged over when developing a pattern of change. It is common for supply line managers to smooth out the inherent volatility in month-to-month demand in the system in this manner. For the model a three-month averaging time was chosen as the default value. For the sensitivity run the supply chain averaging time was adjusted for three, six, and twelve months respectively to determine the affect on the major outputs of the system. Figure 17 below depicts the response of future budget levels with mid-year corrections included for three specific transient conditions. Two demand transients of a 10 percent change were measured as well as a 10 percent budget authority supplemental insertion without a demand change.

In general it can be seen that for demand changes the level of supply line averaging time can significantly affect the budgeting and spending patterns over time. Longer supply line averaging times result in longer response times and longer stabilization times but also reduce the magnitude of budget fluctuations and mid-year corrections. For the exogenous pulse transient however the length of supply line averaging time did not have a significant effect on the system response. This is because the exogenous insertion of money does not result in a

demand transient but creates an inventory transient. Since the inventory level is modeled as being large relative to this change in order rates (an outcome of the higher budget authority) the budget authority deviances are minimal.

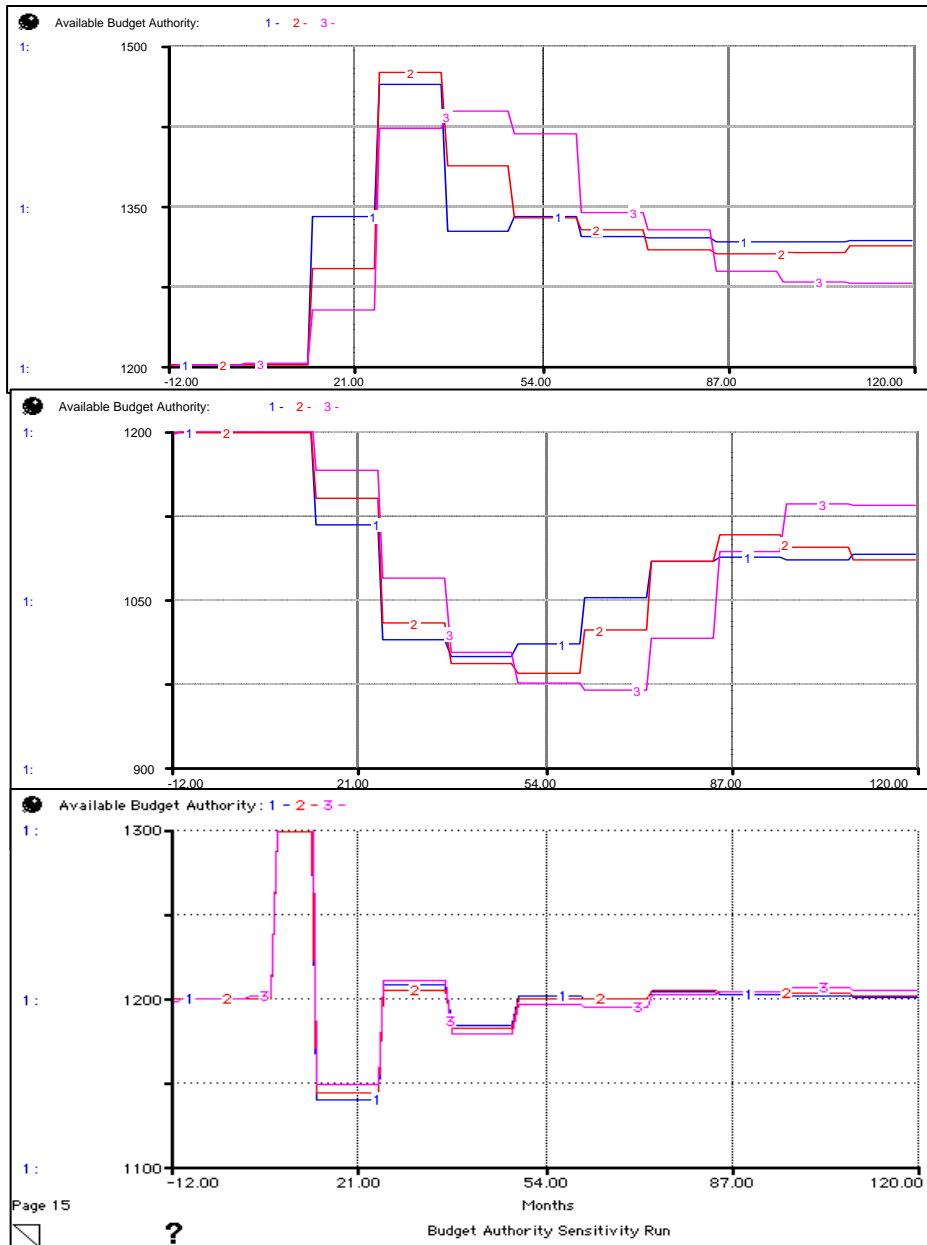

Figure 17. Budget Authority Projections Based on Three, Six, and 12 Month Supply Chain Averaging Times

Another characteristic that can be measured with the sensitivity analysis is the relative amplification of the system when responding to the changes in demand. The following table illustrates the amplification ratios of the overall budget authority response for the given change in demand. The amplification ratio was determined by looking at the percent change in output (budget authority) divided by the percent demand change.

Supply Chain Averaging Time (months)	Demand Change (%)	Budget Authority Change to Peak (%)	Amplification Ratio
3	+10	21.9	2.19
3	-10	-16.9	1.69
6	+10	22.8	2.28
6	-10	-18.2	1.82
12	+10	18.5	1.85
12	-10	-19.4	1.94

Table 2. Amplification Characteristics of Budget Authority With Varying Supply Chain Averaging Times

From the amplification ratios determined above it is possible to see the effect that the supply chain averaging time can have on the ability of the system to correct budget levels to the level that demand would dictate. The supply chain averaging time chosen by the supply manager therefore represents the best balance between short-term responsiveness of the budget authority levels over time and the long term consistency of budget authority levels over a several year period.

## **B. SENSITIVITY TO INVENTORY CORRECTION TIMES**

The second major parameter is interest in the supply chain portion of the model is the time to correct inventory levels to the target condition. The model default correction was set at twelve months. As with the supply chain averaging time an increase and decrease in demand were initiated as well as a supplemental

insertion of budget authority. Figure 18 below illustrates the budget authority projections of the model based on adjustments to the inventory correction time of six, twelve, and eighteen months respectively.

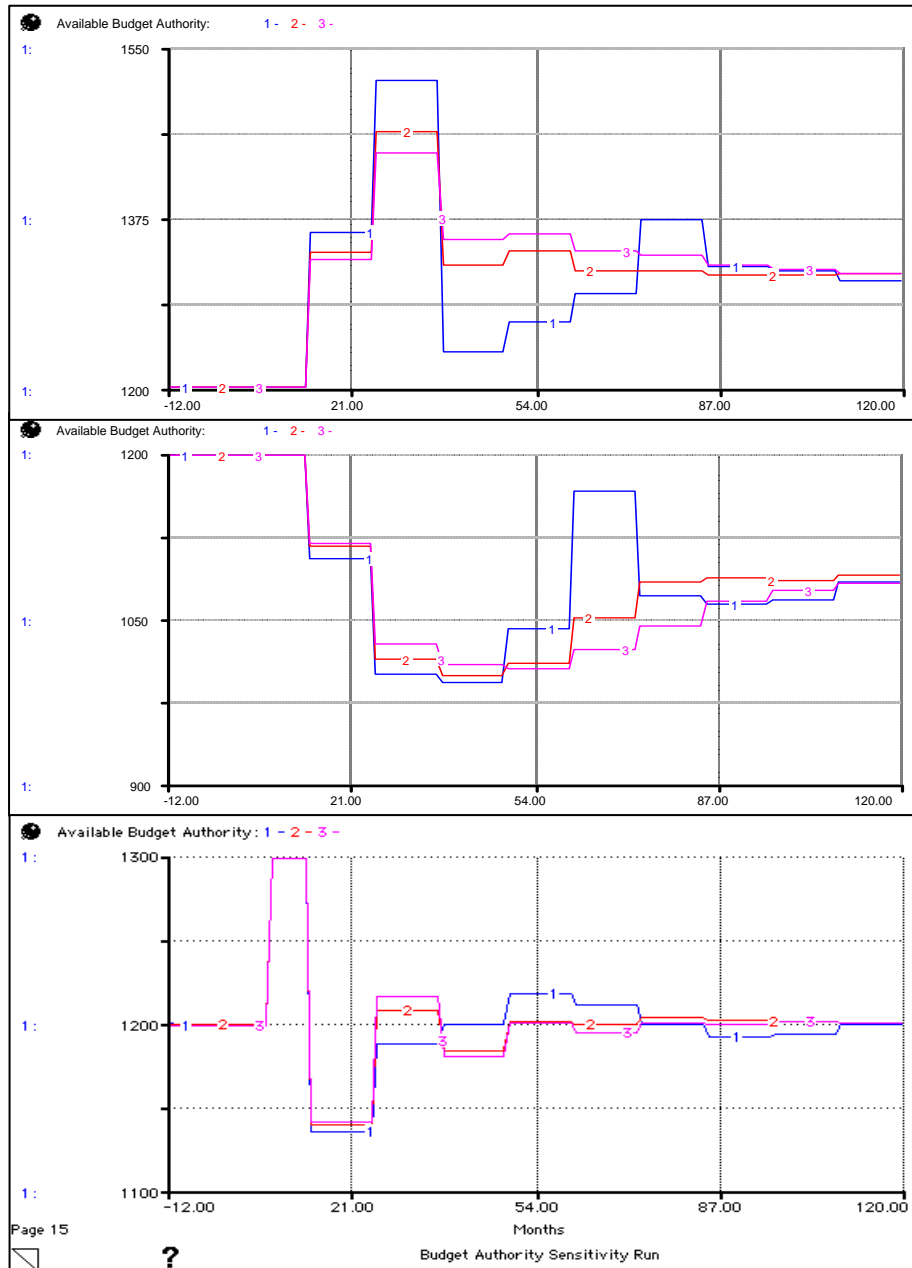

Figure 18. Budget Authority Projections Based On Six, Twelve, and Eighteen Month Inventory Correction Times

As the inventory correction times increase from six months (trial 1) to eighteen months (trial 3) it can be seen that the volatility in the budget authority projections and mid-year corrections decrease. As with the supply chain averaging time measurements the amplification effect can be measured. The results of the amplification measurements are provided below.

Inventory Correction Time (months)	Demand Change (%)	Budget Authority Change to Peak (%)	Amplification Ratio
6	+10	26.3	2.63
6	-10	-17.4	1.74
12	+10	21.9	2.19
12	-10	-16.9	1.69
18	+10	20.2	2.02
18	-10	-16.3	1.63

Table 3. Amplification Characteristics With Six, Twelve, and Eighteen Month Inventory Correction Times

From the amplification data above it is possible to see that, as with supply line averaging times, that there is amplification in the models budget responses to changes in demand. The upward amplification is higher than the downward amplification at any given inventory correction time and shorter times tend to lead to higher amplifications of the models output. Therefore the same basic trade off occurs with this portion of the supply chain management as was previously discussed with the supply line averaging time. Responsiveness in budget outcomes can be improved with shorter inventory correction times but the model indicates that it also significantly increases the variability of both budget outcomes and mid-year corrections.

### C. SENSITIVITY TO BUDGET AVERAGING TIMES

The previous sections have focused on the impact that changes in information processing at the supply chain level have on the overall budget responses on the model. The next major parameter that will be analyzed in this

model is not a function of the supply chain process. When future budgets are developed the budget planners utilize a reference condition that helps them assess changes in overall spending behavior over time. This typically involves the use of historic averages of spending over some period of time in the past. This historic spending level forms the basis from which future budget levels are determined.

The model default was established in chapter 5 as 36 months, or three years, of historic averaging of the spending level. This value was chosen because it closely emulates the actual practice in use by the Navy Comptrollers staff with the use of the Ship Operations Model. However the model responses, indicated by the projected budget outcomes over time, are sensitive to changes in this parameter. The following figure depicts the models responses to three specific budget-averaging times. For this sensitivity run 12, 24, and 36-month times were utilized.

Longer budget averaging times tend to dampen the models response and result in lower magnitude period to period budget authority changes over time. However longer budget averaging times also result in longer times to reach equilibrium conditions when the amount of budgeted funding matches what demand would require. The shorter budget averaging times to result in larger period to period budget authority changes as they make the model more responsive to the demand changes induced. As with the previous runs the level of amplification was measured for each condition of budget averaging time and is provided in the table below. For this sensitivity run the twenty-four month averaging time produced the highest upward amplification and the twelve month averaging time the highest downward amplification.

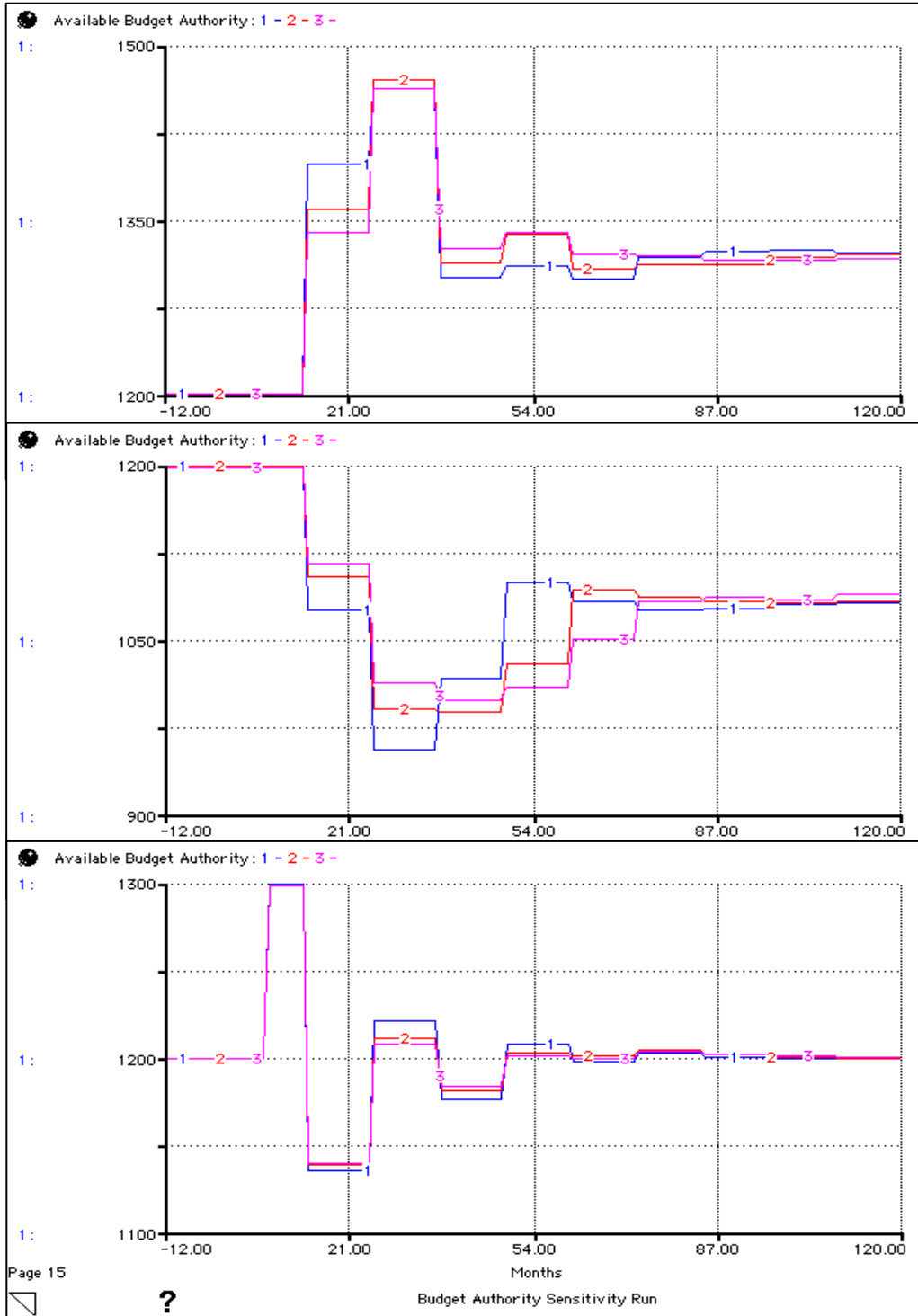

Figure 19. Budget Authority Projections Based on Twelve, Twenty-Four, and Thirty-Six Budget Averaging Times

Budget Averaging Time (months)	Demand Change (%)	Budget Authority Change to Peak (%)	Amplification Ratio
12	+10	21.9	2.19
12	-10	-20.4	2.04
24	+10	22.6	2.26
24	-10	-17.7	1.77
36	+10	21.9	2.19
36	-10	-16.9	1.69

Table 4. Amplification Characteristics With Twelve, Twenty-Four, and Thirty-Six Month Budget Averaging Times

#### **D. IMPLICATIONS OF THE SENSITIVITY ANALYSIS**

The previous sections demonstrated the model sensitivity to major adjustments to control variables both in the supply chain and the budgeting process. There are many other variables within the model that, if adjusted, will change the nature of the budget outcomes over time. The three parameters that were analyzed in the previous sections however represent the major decision variables in the system. Two of these decision variables dealt with how information is received and processes by the supply managers and the third dealt with how the reference spending level that forms the basis for future budget projections was determined.

In this model information about the incoming orders (rate and level) and the changes in inventory (rate and level) can be smoothed with averaging in order to better see trends in these parameters over time. Averaging is necessary because of the inherent volatility of orders on a day-to-day, week-to-week, or a month-to-month basis. This volatility is the result of the probabilistic nature of the demand process itself and cannot be avoided or mitigated. Longer supply chain averaging times do affect the ability of the supply chain manager to see significant changes in demand and adjust order rates accordingly. Shorter

supply chain averaging times tend to result in better perception of short-term trends but do lead to over-compensation and excessive changes in order rates beyond what the change in demand would naturally dictate.

How aggressive the supply chain management is in correcting shortfalls or surpluses in inventory levels also affects the overall response of the system over time. If policy would dictate longer correction times it would tend to make the system less responsive to changes in demand and would result in smaller but more frequent mid-year corrections over time. Policy that shortens or mandates a shorter inventory correction (tighter inventory controls) will result in a pattern of higher volatility caused by over-compensation for inventory level changes. This would result in a highly volatile pattern of budgets over time and larger mid-year corrections to base budget levels. The result could be less confidence by outside agencies in our ability to develop accurate budgets based on demand. As well large mid-year corrections may not be feasible within the larger constraints of the total Navy budget authority in any given year.

Whereas budget planners would therefore desire a longer correction period to the supply chain the inventory managers and end users would desire the opposite condition. Longer periods of backlog and inventory shortfall that could result due to longer supply chain smoothing and inventory correction times could lead to a lack of stock to meet the demand needs of the submarines. This is an operationally undesirable outcome in that mission readiness may be affected if a sudden demand for parts cannot be subsequently filled from the inventory that is available at any given time. Therefore supply chain managers would tend to desire a more responsive budgeting system to meet the more dynamic demand situations as they arise.

The basis for future budget projections starts with an assessment of historic spending levels and patterns. The length of time used to formulate this historic perspective on spending can also significantly affect the responsiveness of the system to changes in demand. As discussed before supply chain managers and repair parts users would prefer a more responsive budgeting

system that could provide money (or take it away) sooner as the supply system follows changes in demand. This would allow for a more accurate amount of funding to be available to meet inventory and demand needs to minimize backlog amounts and inventory fluctuations over time. Shorter budget averaging times can achieve the higher responsiveness in the system when demand changes.

Higher responsiveness in the budgeting system also implies a higher volatility in budget projections due to over and under-compensation to demand changes. Consistency of base budget projections over time are achieved despite the volatile nature of demand however by the use of very long averaging times when forming historic spending patterns. Longer budget averaging times tend to act as a counter balance to keep funding levels in a predictable and consistent range even with significant changes in actual. Longer budget averaging times lead to a more consistent pattern of long range spending that is easier to correlate with long term projections of demand or the planned operational commitments that may drive that demand. Another benefit of a long-range perspective on historic spending is that mid-year corrections tend to be lower when demand changes. A lower need for major budget corrections at the mid-year point helps to instill confidence in the budgeting system to project the right funding level to cover costs that are projected. This is a politically desirable outcome since future budget requests, especially increases in funding, must be credible in order to be approved. This credibility is established in part by our historic accuracy with the budgeting process.

The action to lengthen budget averaging times in order to yield more predictable and consistent funding profiles does significantly affect the supply chain in that inventory shortfalls can persist for much longer periods without correction as the budgeting system adjusts to changes in demand much more slowly than demand itself changes. This can lead to operational readiness problems as available parts, that would be normally available in the supply chain, are not replenished in a timely fashion once order and used for repairs or PMS. This could result in the deferral of repairs or PMS to future periods. However all

of these deferred maintenance items that require parts on backlog order may not be fully funded due to lack of responsiveness of the mid-year correction process and base budget process to demand in the short term.

Overall the balancing of the short term responsiveness, desired by operational commanders and supply chain managers, with the long term consistency desired by the budget planners determines the unique pattern of budget authority that manifest over time as a result of changes in demand. One additional complicating factor in the budget outcomes is the use of exogenous funding to make up for the shortcomings of the budgeting system. In Figures 17 through 19 it can be seen that exogenous insertions of funding also create their own supply chain management transient. In the model sensitivity runs it appears that the supply chain is much more affected by the exogenous insertions of funding than the budgeting system and therefore the supply chain drives the overall response of the system. In general over the sensitivity runs the systems natural response to exogenous funding is to drive future budget projections in the opposite direction in subsequent budget periods. Due to the amplification on the system several the transient continues, with counter-intuitive budget outcomes, for several more budget periods beyond the exogenous insertion.

The following figure illustrates the unique effect that exogenous funding can have on the ability to accurately project budget outcomes. In this simulation run a 10 percent increase in demand was initiated over a three-year period. In order to make up for budget shortfalls an exogenous funding source was provided for the first four years to make up for the shortfall that the mid year correction could not capture. Also included on the graphs is the indicated order rate that the supply chain would require based on the changes to inventory and demand. All of the parameters were normalized to represent percent changes in the values with a value of 100 percent chosen as the starting point. The top graph of the figure illustrates the transient without exogenous funding while the

lower graph shows exogenous funding to cover shortfall or surplus periods as indicated by the difference in indicated order rate (PCT IOR) and the available budget authority (PCT BA).

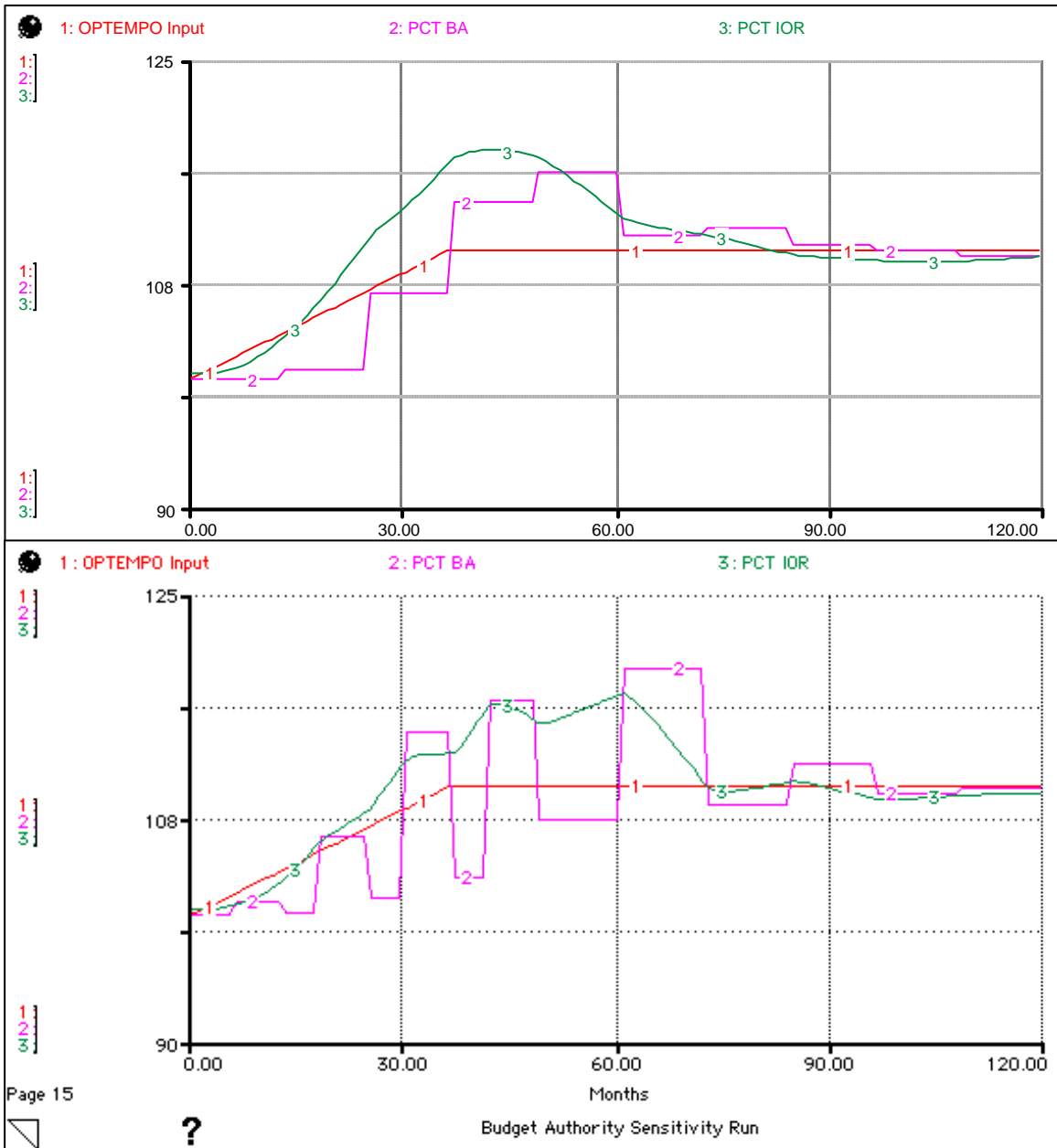

Figure 20. Model Response To Exogenous Funding For Increasing Demand Transient

Note that in the figure the system reacts to the exogenous funding by attempting to project lower budgets in the immediate subsequent period. This requires a larger subsequent exogenous funding insertion to counteract this effect during the transient. This is due to the fact that the exogenous funding exceeds the demands of the supply system during that period and therefore inventory levels rise unexpectedly. The lowering of forecasted budget authority projections in the subsequent budget period naturally counteracts this excess or surplus in funding. This counteraction fights against the exogenous funding purpose and the next exogenous funding “pulse” must also correct for the under-funding condition that the system would project. Therefore the magnitude of exogenous funding required each period increases while the upward demand transient continues. Once the demand transient is over and the exogenous funding is removed inventory levels are much higher than necessary to support the new equilibrium demand and a large correction ensues over several years as inventory, order rates, and demand coalesce to their natural values.

In general it can be concluded that exogenous insertions of money to correct shortfalls in actual funding may result in several years of inconsistent budget projections and volatility in budget outcomes in the modeled system. Future budget projections will still vary considerably after the demand transient is over to correct the supply chain that is in a state of flux from both the demand transient and the exogenous funding. This is because the required order rate that is actually necessary to correct for the demand and inventory changes in the supply system is masked by the behavioral order rate changes that accompany funding excesses above demand in this trial run. This behavior is reinforcing in nature in that as funding reaches surplus levels in the model the indicated order rates rise in order to achieve spending targets. As spending targets are achieved a perception of higher demand is evident despite the rise in inventory over target levels because of the lower weight inventory change has on the indicated order rate. The lower weight of inventory in the indicated orders is the result of the

longer correction time allowed to return inventory levels to the target condition. The result is that the perceived amount of exogenous funding actually rises while inventory rises during the transient.

This is only evident and correctable by the system when the exogenous funding stops and the inventory correction mechanics can attempt to lower future budget projections without competition from the exogenous source.

THIS PAGE INTENTIONALLY LEFT BLANK

## VII. CONCLUSIONS

This thesis work focused on the development of a dynamic model that could both emulate the basic behaviors associated with standard supply chain management, the long range budgeting process, and the spending controls associated with submarine repair OPTAR funding. The concepts of standard supply chain management, and the modeling thereof, were combined with the budgeting policies and procedures to develop the comprehensive system that is the focus of this work. This work focused on the understanding and explanation of the underlying concepts by modeling the basic behaviors and does not represent a validated and accurate model of the actual OPTAR obligations over time.

Whereas previous studies into other aspects of Operations and Maintenance (O&M) funding, including OPTAR, focused on the building of correlations between operational activity and the resultant expenditure patterns this study incorporates other less tangible concepts such as inventory control, supply line management, information processing, trending and smoothing times, and both internal and external correction mechanisms into the process. The result is a spending pattern that is much less determined by current operational activity but rather heavily influenced by previous adjustments, budgets, and demand characteristics.

The goal of this model was not to improve upon the accuracy of any cost estimation or budgeting method in place in this process but to instead develop an understanding of the inherent systems behaviors evident in any system with significant smoothing and delay. The concepts of amplification and oscillation of projected budget outcomes were analyzed and found to exist in all parts of the developed model. The amount of amplification and oscillation can be significant for very small changes in demand and can be complicated by changes to the information processing at both the supply chain and budgeting levels. The model

results indicate that the level of amplification and oscillation change as influences that would require a more responsive budgeting mechanism compete with the equally important influence to maintain predictable and relatively consistent cost projections for future periods. The ultimate budget outcomes for any given condition of demand is the aggregate result of these two active influences in the systems process.

In order to meet the perceived real demands of the repair parts process an external adjustment mechanism was modeled. This can represent reprogramming of funds from another account or supplemental budget amounts. The model results indicate the process of external adjustment provides additional complicating behaviors than may increase the magnitude of year-to-year budget fluctuations as well as significant extension of transient conditions following the termination of external adjustments. The amount of fluctuations from external, or exogenous, adjustments are affected by the same mechanisms that affect the dynamic response of the model to demand transients and therefore can also be significant even for seemingly small changes to allowed budget authority relative to the base budget amount.

This research also attempt to identify a possible reason why previous cost estimation studies, that attempt to find a causal relationship between operational activity (OPTEMPO) and expenditures, may have yielded inconclusive results. As the simulation model demonstrates the actual obligations in any given fiscal period are not only linked to demand in that period but are also heavily influenced by factors such as previous demand history, supply line adjustments, inventory corrections, backlog ordering, and exogenous funding sources. Studies that only look at the relationship between yearly expenditures and the operational activity in that same fiscal period may fail to account for these other factors and therefore fail to provide a significant statistical relationship. In order to provide for better statistical modeling of this process therefore would require the separation of obligations in any period into 1) Those caused by current demand and 2) Those caused by previous and exogenous conditions. Even if that were possible the

manifestation of demand for repair parts, and the obligations that would be incurred, do not necessarily correlate in the same time frame due to the natural buildup and decay of defects in any given system that uses repair parts. Finally the model demonstrates that in steady state conditions where demand does not significantly change the probabilistic nature of breakdowns and defects will create a natural volatility in demand that may never be accurately predicted.

The model in this study demonstrates two fundamental competing desires in this overall repair OPTAR process. The first desire is to have a budgeting system that can readily adapt to changes in demand to provide the necessary funding quickly and prevent significant changes in inventory levels and minimize backlog order buildup. Operational commanders and supply line managers would prefer a system that is more responsive in order to more readily meet demand needs and maintain maximum operational readiness by keeping the submarine force in a condition of minimal disrepair. As the model demonstrates the actions that supply line managers may take to improve responsiveness by changing information processing and averaging times on the supply chain will result in lower backlog levels but it comes at the cost of increased amplification of budget responses to demand and both larger budget forecast variance and mid-year correction levels.

The second competing desire is that held by budget programmers and cost estimators in the process. Highly responsive supply chain management leads to less predictable and more inconsistent budget forecasts unless the volatility is damped. The budget programmers achieve this damping by utilizing long historical averaging of the spending levels. These long averaging times result in less volatile and more consistent budget projections over future periods but make the system less able to control large inventory changes and significant backlogs that may develop. Consistency of budget forecasts provides a level of confidence and assurance to those in the process who authorize and appropriate

funding for future needs. A highly inconsistent budget request pattern with large mid-year corrections would undermine the ability to adequately justify future budget projections based on projected demand alone.

In order to bridge the competing needs of budget programmers and supply line managers an exogenous, or external, form of funding is available to provide additional funding outside of the normal supply and demand process. The model was able to demonstrate that this process can significantly complicate the ability of both parties to understand the true nature of demand or spending history and can actually result in increased volatility and uncertainty in both the true demand picture and the required budget level to meet this real demand. The model also illustrates that it can take several budget periods to correct for this insertion of money into the system even without changes in the underlying demand.

Overall this research into developing a dynamic model of the submarine repair OPTAR process resulted in the identification of behaviors that may also be affecting the spending behavior and budgeting of several other areas of Navy operations and maintenance outside of the scope of this study. The systems modeling process used in this work ultimately resulted in the identification of behaviors that enhance our understanding of why spending outcomes may vary unexpectedly over time rather than any direct cause and effect relationships between operational activity and expenditures. In that way this work may help to explain the unexpected spending variances evident in many other areas where basic supply chain mechanisms are coupled to long range budget projections and strict spending execution requirements.

#### **A. AREAS FOR FURTHER RESEARCH AND MODEL IMPROVEMENT**

This thesis work only touched on the fundamental behaviors evident in this consolidated supply chain management and budgeting system. In that regard the modeled outcomes can only provide general trends in potential spending and budgeting behavior that may accompany any changes in demand or insertions of money into the system outside of the budgeting process. Other areas of systems

behavior in this process that were not included in the model are budget bias, contingency behavior, resource competition, information accuracy, and information processing delay.

Budget bias is an external affect and represents the fact that many times the budget outcomes from the appropriation and allotment processes are not the same as what was requested from the budgeting system. This bias on the budget outcomes can work for or against the systems response to demand depending on whether the budget outcome exceeded or fell short of projections. Contingency behavior represents a reluctance to lower budget forecasts or make mid-year corrections to the levels that the system would indicate. This would in essence result in a lower downward correction in budget amounts when a corresponding decrease in demand occurred.

Resource competition between repair OPTAR and the other O&M accounts for the submarine force is also a realistic effect that was not modeled in this study. The availability of funding necessary to make large mid-year corrections was assumed to always be present in this model. However in real life the availability of funds to reprogram or transfer into the repair OPTAR account is limited to that amount that can be realistically taken from other accounts. Therefore resource competition limits the realistic correction amounts that can occur in any given mid-year period.

In any real world supply chain process there is a finite delay in the processing of order information. Higher accuracy of information (quality) often can only be achieved with additional delays in gathering and processing. The model as built did not include this explicit first order information processing delay in the supply chain system. Inclusion of an additional material delay at this state is somewhat modeled however by the concept of information averaging. However the model assumes that the information received is perfectly accurate and reflective of the true state of the supply chain at any given time. Addition of an accuracy function that is related to the information processing (or smoothing) time would provide a more realistic information signal to adjust order rates with.

In addition this uncertainty of information of the supply chain would alter the way in which supply chain managers respond to changes in demand, backlog orders, and inventory.

This model also is limited in that it has not been calibrated using actual OPTEMPO records or actual inventory levels of repair parts in the submarine force. To simplify the process the inventory levels were assumed to be relatively large when compared to annual demand levels. The size of the standing repair parts inventory does affect the nature of how inventory adjustment affects the system response. A better understanding of the actual standing inventory level of repair parts, and their magnitude relative to annual demand, would provide for a model with improved accuracy of projections and inventory corrections over time. In addition OPTEMPO, as a general measure of operational activity, was assumed to be directly related to the generation of defects in the submarine systems over time. Further studies that can more conclusively link a measure of operational activity to the generation of repair parts demand may show a different cause and effect relationship to be evident. This would alter the model's response to demand and result in a different pattern of projections. In addition other causal variables, such as average ship age, number of systems, or other parameters that may affect the overall amount of repair parts demanded are not modeled in this work.

Finally this model simplified the process of budget adjustment as it occurs throughout any fiscal execution period. In reality the mid-year correction is only one possible correction period that occurs as the fiscal period is executed. More frequent adjustments to individual account levels routinely occur throughout the execution year. These more frequent and smaller adjustments would lower the magnitude of any larger mid-year formal correction to the OPTAR levels and this may result in a less dramatic behavior over time. More research into the relative magnitude difference between routine adjustments and formal mid-year corrections could help improve the mechanics of this process in any future simulation models.

## APPENDIX. MODELING EQUATIONS

This section provides a listing of the major modeling equations used within the Stella ® model of the submarine OPTAR process.

### Budget Formulation and Spending Controls

- Available\_Budget\_Authority(t) = Available\_Budget\_Authority(t - dt) + (Budget\_Allotment\_Rate + Exogenous\_Rate + Correction\_Allotment\_Rate - Budget\_Auth\_Reset) \* dt  
INIT Available\_Budget\_Authority = 2270  
INFLOWS:
  - ⊗ Budget\_Allotment\_Rate = IF(Trigger2>0) THEN PULSE (Future\_\_Budget\_Authority) ELSE 0
  - ⊗ Exogenous\_Rate = Exogenous\_Rate\_Adjustment
  - ⊗ Correction\_Allotment\_Rate = If(Trigger1>0) THEN PULSE (Mid\_Year\_Correction) ELSE 0
 OUTFLOWS:
  - ⊗ Budget\_Auth\_Reset = IF (Trigger2>0) THEN PULSE (Available\_Budget\_Authority) ELSE 0
- Backlog\_Level(t) = Backlog\_Level(t - dt) + (Backlog\_Addition\_Rate - Backlog\_Removal\_Rate) \* dt  
INIT Backlog\_Level = 0  
INFLOWS:
  - ⊗ Backlog\_Addition\_Rate = IOR2
 OUTFLOWS:
  - ⊗ Backlog\_Removal\_Rate = ROR2
- Total\_Obligations(t) = Total\_Obligations(t - dt) + (Indicated\_Obligation\_Rate) \* dt  
INIT Total\_Obligations = 2300  
INFLOWS:
  - ⊗ Indicated\_Obligation\_Rate = Cost\_Per\_Order\*IOR
- Backlog\_Adjustment = Backlog\_Level
- Budget\_Obligation\_Trend = TREND(Total\_Obligations,Budget\_Trending\_Time)
- Budget\_Trending\_Time = 36
- Correction\_Trend = TREND(Total\_Obligations,Correction\_Trending\_Time)
- Correction\_Trending\_Time = 6
- Cost\_Growth\_Rate = 1
- Cost\_Per\_Order = IF (TIME<0) THEN 1 ELSE (1+(Cost\_Growth\_Rate/1200)\*TIME)
- Estimated\_12\_Month\_Obligations = Total\_Obligations+Total\_Obligations\*Budget\_Obligation\_Trend\*12+ Backlog\_Adjustment
- Estimated\_6\_Month\_Budget\_Auth = Estimated\_6\_Month\_Obligations-Total\_Obligations
- Estimated\_6\_Month\_Obligations = Total\_Obligations+Total\_Obligations\*Correction\_Trend\*6
- Exogenous\_Rate\_Adjustment = EAR\_INPUT
- Future\_\_Budget\_Authority = (Estimated\_12\_Month\_Obligations-Total\_Obligations)
- IOR = Indicated\_Order\_Rate
- IOR2 = Indicated\_Order\_Rate
- Mid\_Year\_Correction = (Estimated\_6\_Month\_Budget\_Auth-0.5\*Available\_Budget\_Authority)
- Order\_Rate\_Adjustment = (Target\_Order\_Rate-IOR)/Order\_Rate\_Adj\_Time
- Order\_Rate\_Adj\_Time = 1
- Real\_Order\_Rate = IOR+Order\_Rate\_Adjustment
- Target\_Obligation\_Rate = Available\_Budget\_Authority/12
- Target\_Order\_Rate = Target\_Obligation\_Rate/Cost\_Per\_Order
- Trigger1 = Pulse(1,-720,12)
- Trigger2 = PULSE(1,-720,12)

### Repair Parts Demand Generation

$$\square \text{ Net\_Defective\_Parts}(t) = \text{Net\_Defective\_Parts}(t - dt) + (\text{Defective\_Part\_Production} - \text{PMS\_Demand\_Rate} - \text{Repair\_Demand\_Rate}) * dt$$

INIT Net\_Defective\_Parts = 100

INFLOWS:

$$\square \text{ Defective\_Part\_Production} = \text{SMTH1}(\text{Input} * \text{Defective\_Part\_Proportion}, \text{Defect\_Averaging\_Time})$$

OUTFLOWS:

$$\square \text{ PMS\_Demand\_Rate} = (1 - \text{Breakdown\_Proportion}) * \text{Net\_Defective\_Parts}$$

$$\square \text{ Repair\_Demand\_Rate} = \text{Breakdown\_Proportion} * \text{Net\_Defective\_Parts}$$

$$\circ \text{ Breakdown\_Proportion} = 0.10$$

$$\circ \text{ Defective\_Part\_Proportion} = 1$$

$$\circ \text{ Defect\_Averaging\_Time} = 6$$

$$\circ \text{ Input} = \text{OPTEMPO\_Input}$$

$$\circ \text{ PMS\_Parts\_Demand} = \text{PMS\_Demand\_Rate} * \text{Repair\_Parts\_Per\_PMS\_Task}$$

$$\circ \text{ Repair\_Parts\_Demand} = \text{Repair\_Parts\_Per\_Repair} * \text{Repair\_Demand\_Rate}$$

$$\circ \text{ Repair\_Parts\_Per\_PMS\_Task} = 1$$

$$\circ \text{ Repair\_Parts\_Per\_Repair} = 1$$

### Supply Chain Management

$$\square \text{ Stock\_Inventory}(t) = \text{Stock\_Inventory}(t - dt) + (\text{Acquisition\_Rate} - \text{Total\_Parts\_Demand}) * dt$$

INIT Stock\_Inventory = Target\_Inventory\_Level

INFLOWS:

$$\square \text{ Acquisition\_Rate} = \text{Supply\_Line} * \text{Acquisition\_Delay\_Time}$$

OUTFLOWS:

$$\square \text{ Total\_Parts\_Demand} = \text{TOTAL\_DEMAND}$$

$$\square \text{ Supply\_Line}(t) = \text{Supply\_Line}(t - dt) + (\text{Order\_Rate} - \text{Acquisition\_Rate}) * dt$$

INIT Supply\_Line = 500

INFLOWS:

$$\square \text{ Order\_Rate} = \text{ROR}$$

OUTFLOWS:

$$\square \text{ Acquisition\_Rate} = \text{Supply\_Line} * \text{Acquisition\_Delay\_Time}$$

$$\circ \text{ Acquisition\_Delay\_Time} = 3$$

$$\circ \text{ Desired\_Acquisition\_Rate} = \text{MAX}(0, \text{Smoothed\_Demand} + \text{Stock\_Inventory\_Adjustment})$$

$$\circ \text{ Indicated\_Order\_Rate} = \text{Desired\_Acquisition\_Rate} + \text{Supply\_Line\_Adjustment}$$

$$\circ \text{ Inventory\_Adjustment\_Time} = 12$$

$$\circ \text{ ROR} = \text{Real\_Order\_Rate}$$

$$\circ \text{ Smoothed\_Demand} = \text{SMTH1}(\text{Total\_Parts\_Demand}, \text{Supply\_Chain\_Smoothing\_Time})$$

$$\circ \text{ Smoothed\_Stock\_Inventory} = \text{SMTH1}(\text{Stock\_Inventory}, \text{Supply\_Chain\_Smoothing\_Time}) * 0.9$$

$$\circ \text{ Smoothed\_Supply\_Line} = \text{SMTH1}(\text{Supply\_Line}, \text{Supply\_Chain\_Smoothing\_Time}) * 0.6$$

$$\circ \text{ Stock\_Inventory\_Adjustment} = (\text{Target\_Inventory\_Level} - \text{Smoothed\_Stock\_Inventory}) /$$

$$\circ \text{ Supply\_Adjustment\_Time} = 3$$

$$\circ \text{ Supply\_Chain\_Smoothing\_Time} = 3$$

$$\circ \text{ Supply\_Line\_Adjustment} = (\text{Target\_Supply\_Level} - \text{Smoothed\_Supply\_Line}) / \text{Supply\_Adjustment\_Time}$$

$$\circ \text{ Target\_Inventory\_Level} = 10000$$

$$\circ \text{ Target\_Supply\_Level} = \text{Smoothed\_Demand} * \text{Acquisition\_Delay\_Time}$$

$$\circ \text{ TOTAL\_DEMAND} = \text{PMS\_Parts\_Demand} + \text{Repair\_Parts\_Demand}$$

## LIST OF REFERENCES

- Brandt, J. M., *A Parametric Cost Model for Estimating Operating Costs of U.S. Navy (Non-Nuclear) Surface Ships*. Master's Thesis, Naval Postgraduate School, Monterey, California, June 1999.
- Catalano, J. A. *Toward an OPTAR Allocation Model for Surface Ships of the Pacific Fleet*. Master's Thesis, Naval Postgraduate School, Monterey, California, December 1988.
- Congressional Budgeting Office. *Analysis of the Navy Steaming Days Program*. CBO / NSIAD-89-172, October 1989.
- Hascall, A. M., Matthews, A. M., Gyarmati, M., Gantt, W. K., and Hajdu, Z. *Analysis of Ship Ops Model's Accuracy in Predicting U.S. Naval Ship Operating Cost*. MBA Professional Report, Naval Postgraduate School, June 2003.
- Kuker, K. L. and Craig D. H. *A Feasibility Study of Relating Surface Ships OPTAR Patterns to their Operating Schedules*. Master's Thesis, Naval Postgraduate School, Monterey, California, June 1998.
- Rysavy, J. C. *A Statistical Analysis of Los Angeles Class OPTAR Expenditures Between Pacific Fleet Homeports*. Master's Thesis, Naval Postgraduate School, Monterey, California, June 2007.
- Sterman, J. D. *Business Dynamics – Systems Think and Modeling for a Complex World*. Irwin McGraw-Hill, New York 2000.
- Ting, Chu-wu. *Estimating Operating and Support Cost Models for U.S. Navy Ships*. Master's Thesis, Naval Postgraduate School, Monterey, California, December 1993.
- Williams, T. D. *An Analysis of Selected Surface Ship OPTAR Obligations and their Dependency on Operating Schedules and Other Factors*. Master's Thesis, Naval Postgraduate School, Monterey, California, June 1987.

THIS PAGE INTENTIONALLY LEFT BLANK

## INITIAL DISTRIBUTION LIST

1. Dudley Knox Library  
Naval Postgraduate School  
Monterey, California
2. Professor Tarek Abdel-Hamid  
Naval Postgraduate School  
Monterey, California
3. Professor Philip Candreva  
Naval Postgraduate School  
Monterey, California
4. Professor John E. Muttu  
Naval Postgraduate School  
Monterey, California
5. LT Lynn Trujillo  
Naval Postgraduate School  
Monterey, California