

**FINAL REPORT
DECEMBER 2007**

REPORT NO. 06-25



**TRANSPORTABILITY TESTING OF THE MARINE CORPS
LOGISTICS VEHICLE SYSTEM REPLACEMENT (LVSR)
TP-94-01, REV. 2, JUNE 2004,
“TRANSPORTABILITY TESTING PROCEDURES”**

Prepared for:

Distribution Unlimited:

Marine Corps Systems Command
Product Group – Ground Transportation & Engineer Systems
Program Manager – Motor Transport
2200 Lester Street
Quantico, VA 22134-6050



**DEFENSE AMMUNITION CENTER
VALIDATION ENGINEERING DIVISION
MCALESTER, OKLAHOMA 74501-9053**

20080128292

AVAILABILITY NOTICE

A copy of this report will be furnished each attendee on automatic distribution. Additional copies or authority for reprinting may be obtained by written request from:

Director
U.S. Army Defense Ammunition Center
ATTN: SJMAC-DEV
1 C Tree Road, Bldg. 35
McAlester, OK 74501-9053

DISTRIBUTION INSTRUCTIONS

Destroy this report when no longer needed. Do not return.

Citation of trade names in this report does not constitute an official endorsement.

The information contained herein will not be used for advertising purposes.

**TRANSPORTABILITY TESTING OF THE MARINE CORPS
LOGISTICS VEHICLE SYSTEM REPLACEMENT (LVSR),
TP-94-01, REV. 2, JUNE 2004, "TRANSPORTABILITY TESTING
PROCEDURES"**

ABSTRACT

The U.S. Army Defense Ammunition Center (DAC), Validation Engineering Division (SJMAG-DEV), was tasked by the Program Manager – Motor Transport, Marine Corps Systems Command, to conduct transportability testing on the Logistics Vehicle System Replacement (LVSR) manufactured by Oshkosh Truck Corporation. The testing was conducted in accordance with TP-94-01, Revision 2, June 2004 "Transportability Testing Procedures."

The objective of the testing was to validate the LVSR when transportability tested in accordance with TP-94-01, Revision 2, June 2004.

The following observations resulted from the testing of LVSR:

1. Prior to the start of testing two (2) quarts of water were added to the cooling system.
2. During testing the check fluids light came on and diagnostics showed that the transfer case fluid was low. Two (2) quarts of fluid were added to the transfer case using the onboard system.
3. During later testing, the check fluids light would illuminate and diagnostics showed that the transfer case fluid was low. Once the suspension was leveled and the vehicle warmed up the light would go off.
4. When loading/unloading the M1077 flatrack and Container Roll-In/Out Platform (CROP), the winch would catch on the flipper arms of the front lift adaptor.

5. The rear slider pins were damaged during the unloading of the M1077 flatrack due to operator error.
6. The flatrack and CROP moved side-to-side at the rear of the LVSR during the Hazard Course.
7. The flatrack and CROP moved fore/aft during the panic stops.
8. Final inspection revealed the following:
 - a. The flipper arm pins were bent.
 - b. The remote control box would not operate.
 - c. Throughout testing the vehicle leaked fluid from around the center of the front bumper. (See Photo 26). The center console was removed and the hoses and clamps were inspected. The blue hose in the center console was wet with fluid. The hose clamp was tightened and re-inspected with no additional leakage noted. Prior to and upon completion of testing water was added to the coolant system.

The LVSR, as currently designed, is adequate for the transport of the M1077 and CROPs, on/off road when using web straps to secure the ammunition. The LVSR, as currently designed, is adequate for the transport of M1077 flatracks, by rail and on/off road, when using 2-inch steel banding to secure the ammunition payload. The LVSR successfully completed transportability testing and is approved for transport of ammunition.

Prepared by:

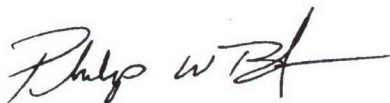

PHILIP W. BARICKMAN
Lead Validation Engineer

Reviewed by:

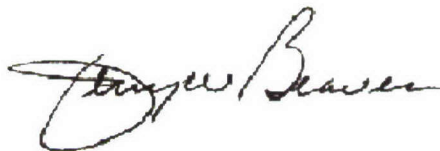

JERRY W. BEAVER
Chief, Validation Engineering Division

U.S. ARMY DEFENSE AMMUNITION CENTER

VALIDATION ENGINEERING DIVISION
MCALESTER, OK 74501-9053

REPORT NO. 06-25

**Transportability Testing of the Marine Corps
Logistics Vehicle System Replacement (LVSR)
TP-94-01, Revision 2, June 2004 “Transportability Testing Procedures”**

TABLE OF CONTENTS

| PART | PAGE NO. |
|------------------------------------------------------------------|----------|
| 1. INTRODUCTION | 1-1 |
| A. BACKGROUND | 1-1 |
| B. AUTHORITY | 1-1 |
| C. OBJECTIVE..... | 1-1 |
| D. OBSERVATIONS | 1-1 |
| E. CONCLUSION..... | 1-2 |
| 2. ATTENDEES..... | 2-1 |
| 3. TEST EQUIPMENT | 3-1 |
| 4. TEST PROCEDURES | 4-1 |
| A. RAIL TEST | 4-1 |
| B. ON/OFF ROAD TESTS | 4-3 |
| 1. HAZARD COURSE | 4-3 |
| 2. ROAD TRIP..... | 4-4 |
| 3. PANIC STOPS | 4-4 |
| 4. WASHBOARD COURSE | 4-4 |
| C. OCEAN-GOING VESSEL TEST. Shipboard Transportation Simulator . | 4-4 |
| 5. TEST RESULTS..... | 5-1 |
| 5.1 TESTING..... | 5-1 |
| A. ON/OFF ROAD TESTS –19 SEPTEMBER 2007..... | 5-3 |
| 1. HAZARD COURSE | 5-3 |
| 2. ROAD TRIP | 5-4 |
| 3. PANIC STOPS | 5-4 |
| 4. HAZARD COURSE | 5-6 |
| 5. WASHBOARD COURSE..... | 5-6 |
| B. ON/OFF ROAD TESTS – 25 SEPTEMBER 2007..... | 5-7 |
| 1. HAZARD COURSE | 5-8 |
| 2. ROAD TRIP | 5-8 |
| 3. PANIC STOPS | 5-9 |

| | | |
|-----|-------------------------------------------|------|
| C. | ON/OFF ROAD TESTS – 2 OCTOBER 2007 | 5-10 |
| 1. | HAZARD COURSE | 5-11 |
| 2. | ROAD TRIP | 5-11 |
| 3. | PANIC STOPS | 5-12 |
| D. | ON/OFF ROAD TESTS – 10 OCTOBER 2007 | 5-12 |
| 1. | HAZARD COURSE | 5-13 |
| 2. | ROAD TRIP | 5-14 |
| 3. | PANIC STOPS | 5-14 |
| 4. | HAZARD COURSE | 5-15 |
| 5. | WASHBOARD COURSE..... | 5-15 |
| E. | CONCLUSION | 5-16 |
| 5.2 | TESTING DATE –21 SEPTEMBER 2007 | 5-17 |
| A. | ON/OFF ROAD TESTS..... | 5-17 |
| 1. | HAZARD COURSE | 5-18 |
| 2. | ROAD TRIP | 5-19 |
| 3. | PANIC STOPS | 5-19 |
| 4. | HAZARD COURSE | 5-19 |
| 5. | WASHBOARD COURSE..... | 5-20 |
| B. | CONCLUSION | 5-20 |
| 5.3 | TESTING..... | 5-21 |
| A. | RAIL TEST –18-23 OCTOBER 2007 | 5-21 |
| B. | ON/OFF ROAD TESTS..... | 5-23 |
| 1. | HAZARD COURSE | 5-23 |
| 2. | ROAD TRIP | 5-24 |
| 3. | PANIC STOPS | 5-24 |
| 4. | HAZARD COURSE | 5-24 |
| 5. | WASHBOARD COURSE..... | 5-25 |
| C. | OBSERVATION | 5-26 |
| D. | CONCLUSION..... | 5-27 |
| 6. | DRAWINGS..... | 6-1 |

PART 1 – INTRODUCTION

A. BACKGROUND. The U.S. Army Defense Ammunition Center (DAC), Validation Engineering Division (SJMAC-DEV), was tasked by the Program Manager – Motor Transport, Marine Corps Systems Command, to conduct transportability testing on the Logistics Vehicle System Replacement (LVSR) manufactured by Oshkosh Truck Corporation. The testing was conducted in accordance with TP-94-01, Revision 2, June 2004 “Transportability Testing Procedures.”

B. AUTHORITY. This test was conducted IAW mission responsibilities delegated by the U.S. Army Joint Munitions Command (JMC), Rock Island, IL. Reference is made to the following:

1. AR 740-1, 15 June 2001, Storage and Supply Activity Operation.
2. OSC-R, 10-23, Mission and Major Functions of U.S. Army Defense Ammunition Center (DAC) 21 Nov 2000.

C. OBJECTIVE. The objective of the testing was to validate the LVSR when transportability tested in accordance with TP-94-01, Revision 2, June 2004.

D. OBSERVATIONS. The following observations resulted from the testing of LWPM:

1. Prior to the start of testing two (2) quarts of water were added to the cooling system.
2. During testing the check fluids light came on and diagnostics showed that the transfer case fluid was low. Two (2) quarts of fluid were added to the transfer case using the onboard system.
3. During later testing, the check fluids light would illuminate and diagnostics showed that the transfer case fluid was low. Once the suspension was leveled and the vehicle warmed up, the light would go off.

4. When loading/unloading the M1077 flatrack and Container Roll-in/Out Platform (CROP), the winch would catch on the flipper arms of the front lift adaptor.
5. The rear slider pins were damaged during the unloading of the M1077 flatrack due to operator error.
6. The flatrack and CROP moved side-to-side at the rear of the LVSR during the Hazard Course.
7. The flatrack and CROP moved fore/aft during the panic stops.
8. Final inspection revealed the following:
 - a. The flipper arm pins were bent.
 - b. The remote control box would not operate.
 - c. Throughout testing the vehicle leaked fluid from around the center of the front bumper. (See Photo 26). The center console was removed and the hoses and clamps were inspected. The blue hose in the center console was wet with fluid. The hose clamp was tightened and re-inspected with no additional leakage noted. Prior to and upon completion of testing, water was added to the coolant system.

E. CONCLUSIONS. The LVSR, as currently designed, is adequate for the transport of the M1077 and CROPs, on/off road when using web straps to secure the ammunition. The LVSR, as currently designed, is adequate for the transport of M1077 flatracks, by rail and on/off road, when using 2-inch steel banding to secure the ammunition payload. The LVSR successfully completed transportability testing and is approved for transport of ammunition.

PART 2 - ATTENDEES

ATTENDEE

Philip Barickman
DSN 956-8992
(918) 420-8992

Michael Bartosiak
DSN 956-8083
(918) 420-8083

MAILING ADDRESS

Director
U.S. Army Defense Ammunition Center
ATTN: SJMAC-DEV
1 C Tree Road, Bldg. 35
McAlester, OK 74501-9053

Director
U.S. Army Defense Ammunition Center
ATTN: SJMAC-DET
1 C Tree Road, Bldg. 35
McAlester, OK 74501-9053

PART 3 - TEST EQUIPMENT

1. Logistics Vehicle System Replacement (LVSR)

Model: MKR18 Truck, Cargo, LVSR

VIN: 10TKLAM167S094226

Manufactured by Oshkosh Truck Corporation

Contract No: M67854-06-D-5028

Date of Manufacture; 07/2007

Curb Weight: 53,650 pounds

2. Flatrack

Model Number: M1077

NSN: 3990-01-307-7676

Manufactured by Oshkosh Truck Corporation

Contract Number: DAAE07-90-C-R035

Date of Manufacture: 01/1994

Curb Weight: 3,200 pounds

3. Flatrack

Model Number: M1077

NSN: 3990-01-307-7676

Manufactured by Oshkosh Truck Corporation

Contract Number: DAAE07-90-C-R035

Date of Manufacture: 06/1993

Curb Weight: 3,200 pounds

4. Container Roll-In/Out Platform (CROP)

Model Number: M3 Flatrack

NSN: 3990 01 447 2751

Manufactured by: Summa Technology Inc.

Contract Number: DAAE07-96-C-X083

Tare Weight: 3,650 pounds

PART 4 - TEST PROCEDURES

The test procedures outlined in this section were extracted from TP-94-01, "Transportability Testing Procedures," Revision 2, June 2004, for validating tactical vehicles and outloading procedures used for shipping munitions by tactical truck, railcar, and ocean-going vessel.

The rail impact will be conducted with the loaded intermodal container secured directly to the railcar. Inert (non-explosive) items were used to build the load. The test loads were prepared using the blocking and bracing procedures proposed for use with munitions (**see Part 6 – Drawings for procedures**). The weight and physical characteristics (weights, physical dimensions, center of gravity, etc.) of the test loads were similar to live (explosive) ammunition.

A. RAIL TEST. RAIL IMPACT TEST METHOD. The test load or vehicle will be secured to a flatcar. The equipment needed to perform the test will include the specimen (hammer) car, four empty railroad cars connected together to serve as the anvil, and a railroad locomotive. The anvil cars will be positioned on a level section of track with air and hand brakes set and with draft gears compressed. The locomotive unit will push the specimen car toward the anvil at a predetermined speed, then disconnect from the specimen car approximately 50 yards away from the anvil cars allowing the specimen car to roll freely along the track until it strikes the anvil. This will constitute an impact. Impacting will be accomplished at speeds of 4, 6, and 8.1 mph in one direction and at a speed of 8.1 mph in the reverse direction. The tolerance for the speeds is plus 0.5 mph, minus 0.5 mph for the 4 mph and 6 mph impacts, and plus 0.5 mph, minus 0 mph for the 8.1 mph impacts. The impact speeds will be determined by using an electronic counter to measure the time for the specimen car to traverse an 11-foot distance immediately prior to contact with the anvil cars (see Figure 1).

**ASSOCIATION OF AMERICAN RAILROADS (AAR)
STANDARD TEST PLAN**

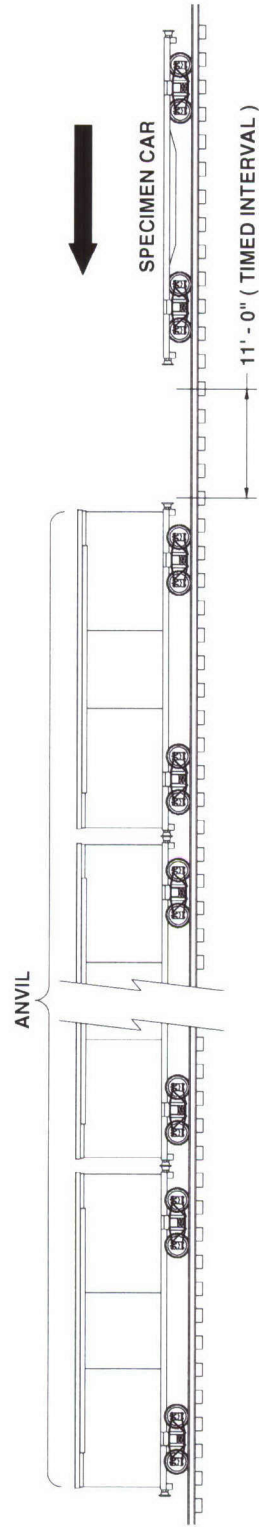

**4 BUFFER CARS (ANVIL)
WITH DRAFT GEAR
COMPRESSED AND AIR BRAKES IN A SET
POSITION**

ANVIL CAR TOTAL WT. 250,000 LBS (APPROX)

**SPECIMEN CAR IS RELEASED BY SWITCH ENGINE
TO**

ATTAIN: IMPACT NO. 1 @ 4 MPH

IMPACT NO. 2 @ 6 MPH

IMPACT NO. 3 @ 8.1 MPH

**THEN THE CAR IS REVERSED AND RELEASED BY
SWITCH ENGINE TO ATTAIN:**

IMPACT NO. 4 @ 8.1 MPH

Figure 1. Rail Impact Sketch

B. ON/OFF ROAD TEST.

1. HAZARD COURSE. The test load or vehicle will be transported over the 200-foot-long segment of concrete-paved road consisting of two series of railroad ties projecting 6 inches above the level of the road surface. The hazard course will be traversed two times (see Figure 2).

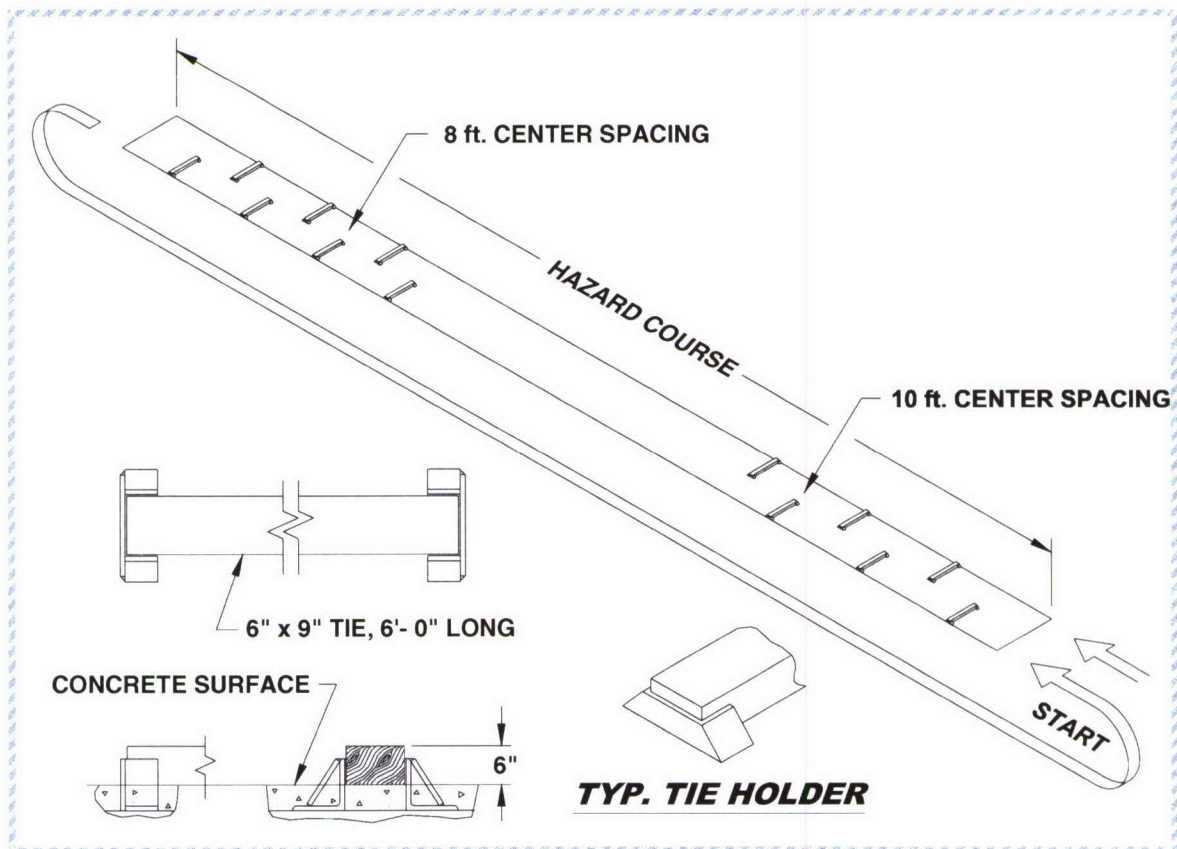

Figure 2. Hazard Course Sketch

- a. The first series of 6 ties are spaced on 10-foot centers and alternately positioned on opposite sides of the road centerline for a distance of 50 feet.
- b. Following the first series of ties, a paved roadway of 75 feet separates the first and second series of railroad ties.

c. The second series of 7 ties are spaced on 8-foot centers and alternately positioned on opposite sides of the road centerline for a distance of 48 feet.

d. The test load is driven across the hazard course at speeds that will produce the most violent vertical and side-to-side rolling reaction obtainable in traversing the hazard course (approximately 5 mph).

2. ROAD TRIP. The test load or vehicle will be transported for a distance of 30 miles over a combination of roads surfaced with gravel, concrete, and asphalt. The test route will include curves, corners, railroad crossings and stops and starts. The test load or vehicle will travel at the maximum speed for the particular road being traversed, except as limited by legal restrictions.

3. PANIC STOPS. During the road trip, the test load or vehicle will be subjected to three (3) full airbrake stops while traveling in the forward direction and one in the reverse direction while traveling down a 7 percent grade. The first three stops are at 5, 10, and 15 mph while the stop in the reverse direction is approximately 5 mph. This testing will not be required if the Rail Impact Test is performed.

4. WASHBOARD COURSE. The test load or vehicle will be driven over the washboard course at a speed that produces the most violent response in the vertical direction.

C. OCEAN-GOING VESSEL TEST. Shipboard Transportation Simulator (Test Method 5). The Shipboard Transportation Simulator (STS) is used for testing loads in 8-foot-wide by 20-foot-long intermodal freight containers. The specimen shall be positioned onto the STS and securely locked in place using the cam lock at each corner. Using the procedure detailed in the operating instructions, the STS shall begin oscillating at an angle of 30 degrees, plus or minus 2 degrees, either side of vertical center and a frequency of 2 cycles-per-

minute (30 seconds, plus or minus 2 seconds) for a duration of two (2) hours. This frequency shall be observed for apparent defects that could cause a safety hazard. The frequency of oscillation shall then be increased to 4 cycles-per-minute (15 seconds, plus or minus one second per cycle) and the apparatus operated for two (2) hours. If an inspection of the load does not indicate an impending failure, the frequency of oscillation shall be further increased to 5 cycles-per-minute (12 seconds, plus or minus one second per cycle), and the apparatus operated for four (4) hours. The operation does not necessarily have to be continuous; however, no changes or adjustments to the load or load restraints shall be permitted at any time during the test. After once being set in place, the test load (specimen) shall not be removed from the apparatus until the test has been completed or is terminated.

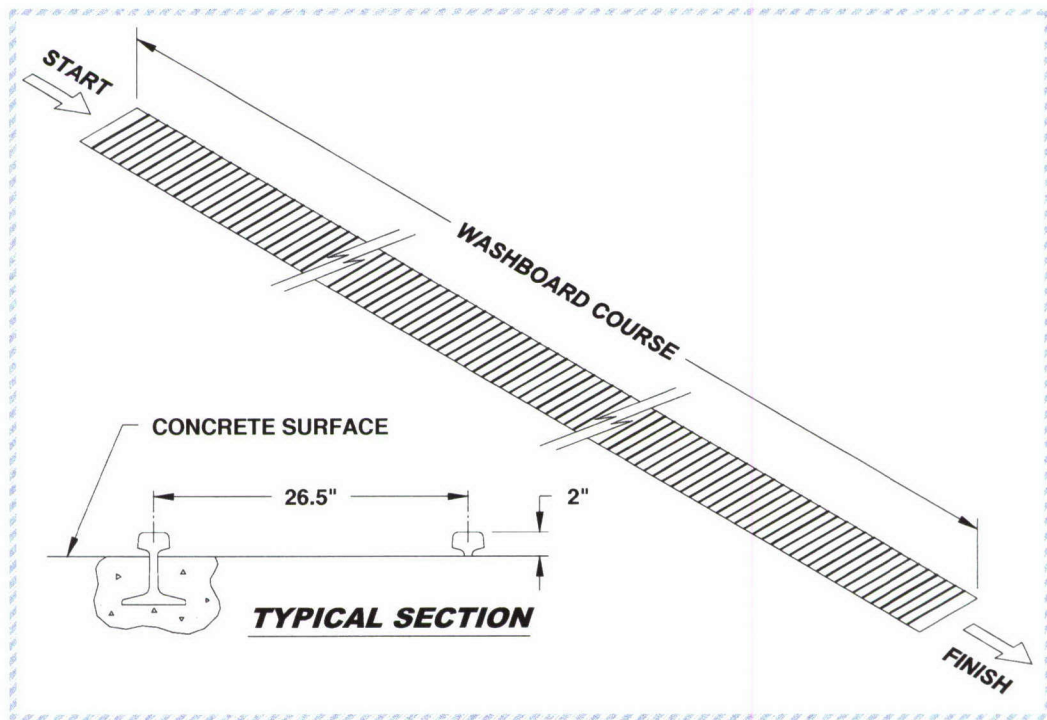

Figure 3. Washboard Course Sketch

PART 5 - TEST RESULTS

5.1

Test Specimen: Logistics Vehicle System Replacement (LVSR)

Payload: M1077 Flatrack Loaded with 120MM Cartridges

Gross Weight: 81, 240 pounds (Including vehicle, ammunition and dunnage).

Payload Weight: 28,220 pounds

Notes:

1. Prior to the start of testing, two (2) quarts of water were added to the cooling system.
2. Prior to the start of testing, the “check fluids” light came on and diagnostics showed that the transfer case fluid was low. One (1) quart of fluid was added to the transfer case using the onboard system. Excessive caulk had to be removed in order to properly identify the transfer hoses. Once the caulk was removed, the fluid was added to the transfer case.

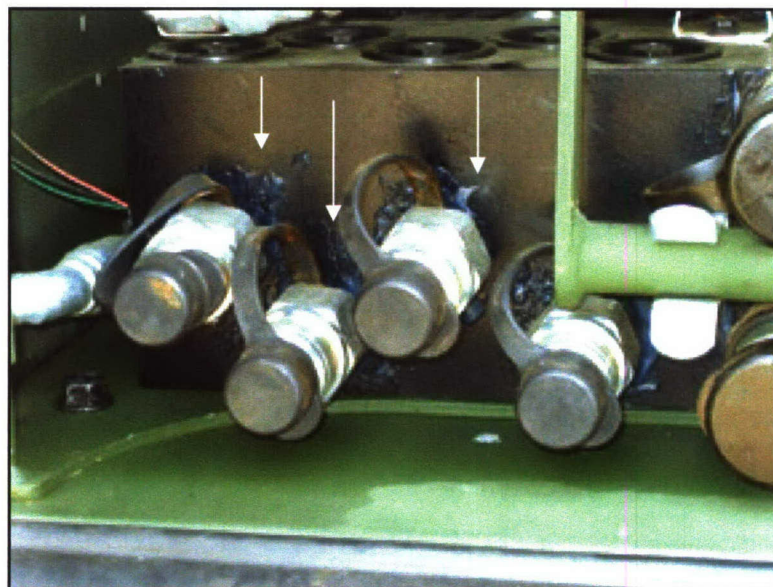

Photo 1. Obscured Markings

3. When loading/unloading the flatrack, the winch hook would catch on the flipper arms of the front lift adaptor (FLA). A strap was added to hold the flipper arms back.

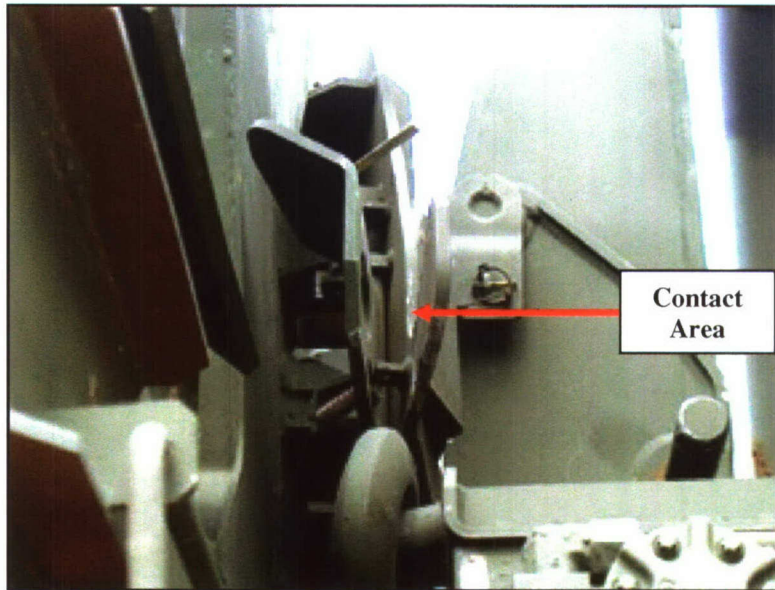

Photo 2. Contact with Front Lift Adaptor



Photo 3. Strap Holding Flipper Arms

4. During the reverse Panic Stops, the payload moved excessively and the rear pallet posts were damaged and web straps failed when secured in accordance with AMC Drawing 19-48 4903. Different strapping configurations were follow-on tested, and the strapping configuration used on

10/10/2007 was minimally adequate to properly restrain the ammunition payload. See Photos 5 and 10 for ammunition movement and Photos 6, 11, and 14 for strap failures and pallet damage.

A. ON/OFF ROAD TESTS. Testing Date: 19 September 2007

1. HAZARD COURSE.



Photo 4. Hazard Course Testing of the LVSR

| Pass No. | Elapsed Time | Avg. Velocity (mph) |
|-----------------|---------------------|----------------------------|
| 1 | 26.4 Seconds | 5.3 |
| 2 | 26.4 Seconds | 5.3 |

Figure 4.

Remarks:

1. Figure 4 lists the average speeds of the test load through the Hazard Course.
2. Inspection following each pass did not reveal any damage to the payload, flatrack, or LVSR.

2. ROAD TRIP:

Remarks:

1. The Road Trip was commenced following the Road Hazard Course Pass #2.
2. The Road Trip was not continued after the reverse 5 MPH Panic Stop due to excessive moment of the payload and pallet damage.

3. PANIC STOPS:

Remarks:

1. The Panic Stops were conducted during the Road Trip.
2. Prior to the start of the Panic Stops, the “check fluids” light came on and diagnostics showed that the transfer case fluid was low. One (1) quart of fluid was added to the transfer case using the onboard system. Also the “check filters” light came on prior to adding the fluid to the transfer case. Once the vehicle was restarted, the “check filters” light was no longer illuminated.
3. Following the forward 5 MPH Panic Stop, the flatrack moved in the direction of the stop 1-inch.
4. Following the reverse 5 MPH Panic Stop, the load shifted in the direction of the stop 9-inches. The pallet posts were damaged during the reverse Panic Stop. See Photo 5 for payload movement and Photo 6 for pallet post damage.
5. Official testing was stopped due to excessive movement of the payload and pallet damage.



Photo 5. Movement of Payload from Front Wall.

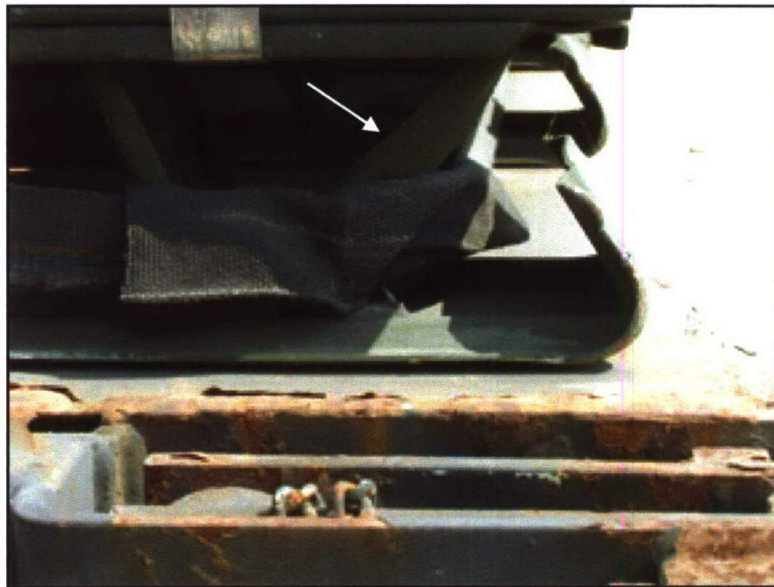

Photo 6. Pallet Post Damage.

6. An additional forward Panic Stop was conducted and the straps were retightened.

4. HAZARD COURSE.

Note: Hazard Course testing was continued and conducted for evaluation purposes only.

| Pass No. | Elapsed Time | Avg. Velocity (mph) |
|----------|--------------|---------------------|
| 3 | 26.0 Seconds | 5.4 |
| 4 | 25.9 Seconds | 5.4 |

Figure 5.

Remarks:

1. Figure 5 lists the average speeds of the test load through the Hazard Course.
2. Inspection following the completion of Pass #3 revealed that the flatrack had moved back 1-inch.
3. The flatrack moved side-to-side at the rear of the LVSR 1-inch.

4. WASHBOARD COURSE:

Remarks:

1. Inspection following the completion of the Washboard Course did not reveal any damage to the payload, flatrack, or LVSR. Inspection did reveal that the flatrack had moved forward 1-inch.
2. The rear slider pins were damaged during the unloading operation due to operator error.



Photo 7. Washboard Course Testing of the LVSR.

B. ON/OFF ROAD TESTS.

Testing Date: 25 September 2007

Note: The rear pallets of the test load were turned at 90 degrees from the previous tested orientation and strapped. See Photo 8.



Photo 8. Rotated Rear Pallets

1. HAZARD COURSE.



Photo 9. Hazard Course Testing of the LVSR

| Pass No. | Elapsed Time | Avg. Velocity (mph) |
|----------|--------------|---------------------|
| 1 | 25.6 Seconds | 5.4 |
| 2 | 26.2 Seconds | 5.3 |

Figure 6.

Remarks:

1. Figure 6 lists the average speeds of the test load through the Hazard Course.
2. Inspection following each pass did not reveal any damage to the payload, flatrack, or LVSR.
3. The M1077 flatrack moved side-to-side at the rear of the LVSR vehicle up to 1-inch during Passes #1 & #2.

2. ROAD TRIP:

Remarks:

1. The Road Trip was commenced following Road Hazard Course Pass #2.
2. The Road Trip was not continued after the reverse 5 MPH Panic Stop due to excessive moment of the payload and pallet damage.

3. PANIC STOPS:

Remarks:

1. The Panic Stops were conducted during the Road Trip.
2. Following the reverse 5 MPH Panic Stop, the load shifted in the direction of the stop 10.5-inches and sheared the bottom strap. The rear pallet posts fatigued. See Photo 10 for payload movement and Photo 11 for sheared bottom strap.
3. Testing was stopped due to the excessive movement of the payload and the pallet damage.



Photo 10. Movement of Payload from Front Wall.



Photo 11. Sheared Bottom Strap.

C. ON/OFF ROAD TESTS.

Testing Date: 2 October 2007

Note: The rear pallets of the test load were turned back to the original starting position and secured using two straps. See Photo 12.

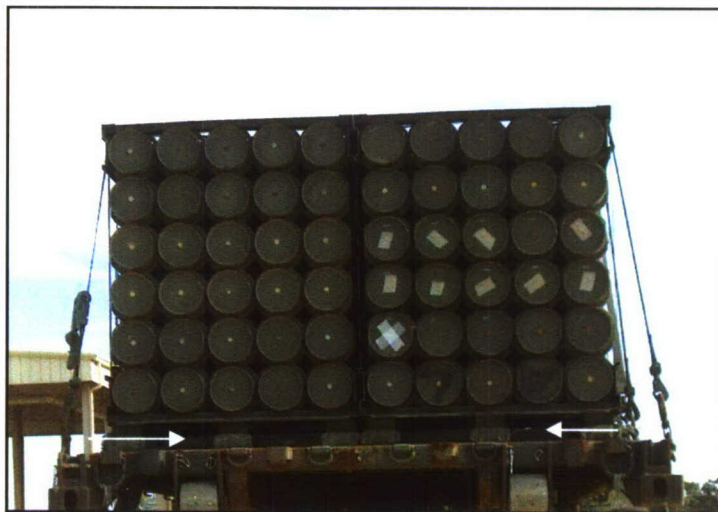

Photo 12. Rear Pallet Bases Secured Using 2-Straps.

1. HAZARD COURSE.



Photo 13. Hazard Course Testing of the LVSR

| Pass No. | Elapsed Time | Avg. Velocity (mph) |
|----------|--------------|---------------------|
| 1 | 25.9 Seconds | 5.4 |
| 2 | 26.2 Seconds | 5.3 |

Figure 7.

Remarks:

1. Figure 7 lists the average speeds of the test load through the Hazard Course.
2. Inspection following each pass did not reveal any damage to the payload, flatrack, or LVSR.
3. The M1077 flatrack moved side-to-side at the rear of the LVSR vehicle up to 1-inch during Passes #1 & #2.

2. ROAD TRIP:

Remarks:

1. The Road Trip was commenced following the Road Hazard Course Pass #2.

2. The Road Trip was not continued after the reverse 5 MPH Panic Stop due to excessive moment of the payload and pallet damage.

3. PANIC STOPS:

Remarks:

1. The Panic Stops were conducted during the Road Trip.
2. Following the forward 5 MPH Panic Stop, the flatrack moved in the direction of the stop 0.75 inches.
3. Following the reverse 5 MPH Panic Stop, the load shifted in the direction of the stop 6-inches. The rear pallet posts fatigued. See Photo 14 for pallet post damage.
4. Testing was stopped due to the excessive movement of the payload and the pallet damage.

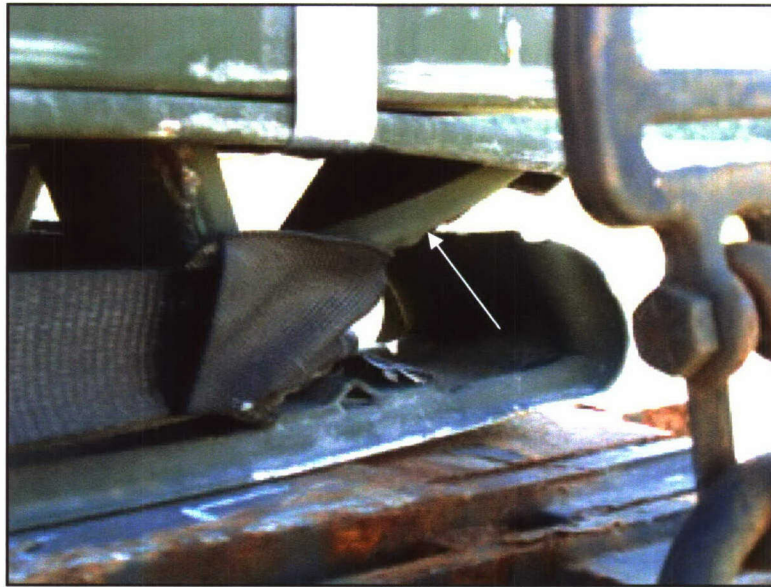

Photo 14. Fatigued Pallet Post.

D. ON/OFF ROAD TESTS.

Testing Date: 10 October 2007

Note: An additional bottom strap was added between the third and fourth row of pallets.

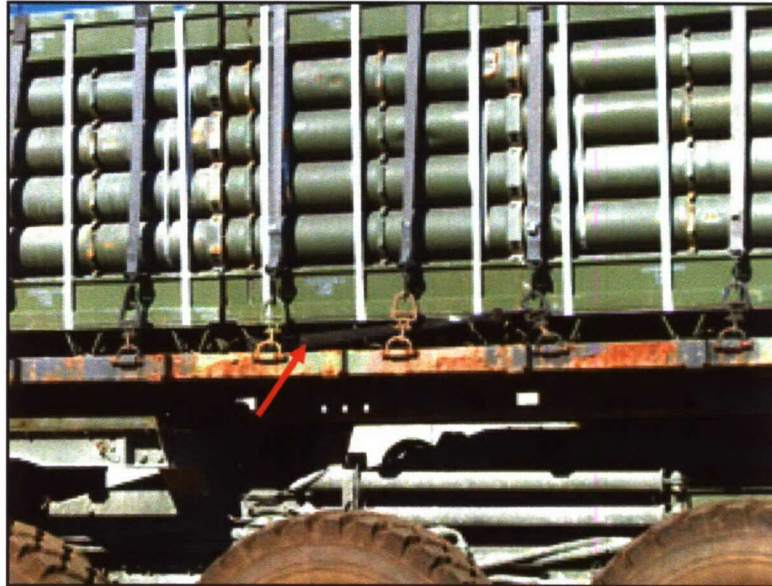

Photo 15. Additional Strap between Pallet Rows 3 & 4.

1. HAZARD COURSE.



Photo 16. Hazard Course Testing of the LVSR.

| Pass No. | Elapsed Time | Avg. Velocity (mph) |
|----------|--------------|---------------------|
| 1 | 26.3 Seconds | 5.3 |
| 2 | 25.3 Seconds | 5.5 |

Figure 8.

Remarks:

1. Figure 8 lists the average speeds of the test load through the Hazard Course.
2. Inspection following each pass did not reveal any damage to the payload, flatrack, or LVSR.
3. The M1077 flatrack moved side-to-side at the rear of the LVSR vehicle up to 1-inch during Passes #1 & #2.

2. ROAD TRIP:

Remarks:

1. The Road Trip was conducted between the Road Hazard Course Passes #2 and #3.
2. Inspection following the Road Trip did not reveal any damage to the payload, flatrack, or LVSR.

3. PANIC STOPS:

Remarks:

1. The Panic Stops were conducted during the Road Trip.
2. Following the forward 5 MPH Panic Stop, the load shifted in the direction of the stop 1-inch and the flatrack moved forward 1-inch.
3. Following the reverse 5 MPH Panic Stop, the load shifted in the direction of the stop 6.5 inches. The pallet center posts slightly deformed.

5. HAZARD COURSE:

| Pass No. | Elapsed Time | Avg. Velocity (mph) |
|----------|--------------|---------------------|
| 3 | 26.3 Seconds | 5.3 |
| 4 | 26.3 Seconds | 5.3 |

Figure 9.

Remarks:

1. Figure 9 lists the average speeds of the test load through the Hazard Course.
2. Inspection following each pass did not reveal any damage to the payload, flatrack, or LVSR.
3. The M1077 flatrack moved side-to-side at the rear of the LVSR vehicle up to 1-inch during Passes #3 & #4.

6. WASHBOARD COURSE:

Remarks: Inspection following completion of the Washboard Course did not reveal any damage to the payload, flatrack, or LVSR.



Photo 17. Washboard Course Testing of the LVSR.

E. CONCLUSION: The LVSR, as currently designed, is adequate to transport M1077 flatracks, on/off road, when using web straps to secure the ammunition payload.

5.2

Test Specimen: Logistics Vehicle System Replacement (LVSR)

Payload: Summa CROP with 155MM Separate Loading Projectiles (SLPs)

Testing Date: 21 September 2007

Gross Weight: 87,600 pounds (Including vehicle, ammunition and dunnage).

Payload Weight: 34,740 pounds

Note: The corner blocks on the CROP do not rest on the landing pads on the LVSR.

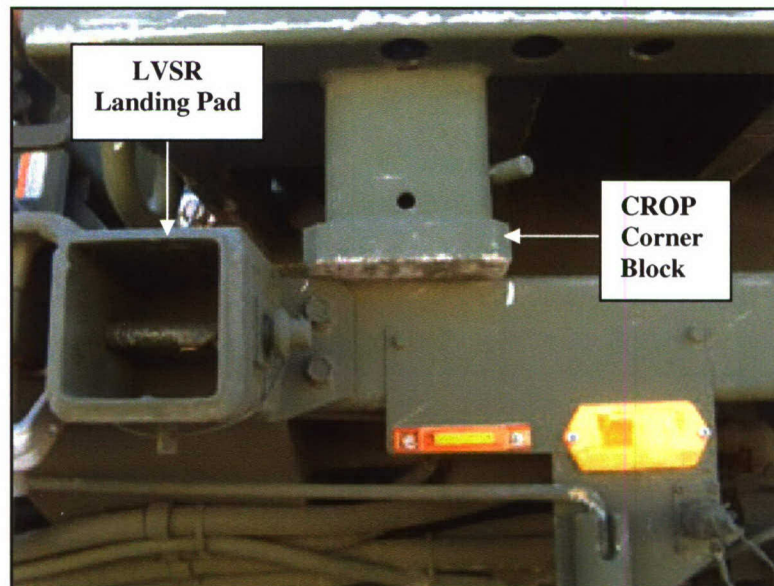

Photo 18. CROP Corner Blocks Not Resting on LVSR Landing Pads.

A. ON/OFF ROAD TESTS.

1. HAZARD COURSE.



Photo 19. Hazard Course Testing of the LVSR

| Pass No. | Elapsed Time | Avg. Velocity (mph) |
|-----------------|---------------------|----------------------------|
| 1 | 24.5 Seconds | 5.7 |
| 2 | 26.6 Seconds | 5.2 |

Figure 10.

Remarks:

1. Figure 10 lists the average speeds of the test load through the Hazard Course.
2. Inspection following each pass did not reveal any damage to the payload, flatrack, or LVSR.
3. The CROP moved side-to-side at the rear of the LVSR vehicle up to 1-inch during Passes #1 & #2.

2. ROAD TRIP:

Remarks:

1. The Road Trip was conducted between the Road Hazard Course Passes #2 and #3.
2. Inspection following the Road Trip did not reveal any damage to the payload, CROP, or LVSR.

3. PANIC STOPS:

Remarks:

1. The Panic Stops were conducted during the Road Trip.
2. Following the forward 5 MPH Panic Stop, the CROP moved in the direction of the stop 0.75 inches.
3. Following the forward 10 MPH Panic Stop, the CROP moved in the direction of the stop an additional 0.25 inches.
4. Following the reverse 5 MPH Panic Stop, the CROP moved in the direction of the stop 1-inch.

4. HAZARD COURSE:

| Pass No. | Elapsed Time | Avg. Velocity (mph) |
|----------|--------------|---------------------|
| 3 | 26.3 Seconds | 5.3 |
| 4 | 26.1 Seconds | 5.3 |

Figure 11.

Remarks:

1. Figure 11 lists the average speeds of the test load through the Hazard Course.
2. Inspection following each pass did not reveal any damage to the payload, CROP, or LVSR.
3. The CROP moved side-to-side at the rear of the LVSR vehicle up to 1-inch during Passes #3 & #4.

5. WASHBOARD COURSE:

Remarks: Inspection following the completion of the Washboard Course did not reveal any damage to the payload, CROP, or LVSR.



Photo 20. Washboard Course Testing of the LVSR.

B. CONCLUSION: The LVSR, as currently designed, is adequate to transport the CROP, on/off road, when using web straps to secure the ammunition payload.

5.3

Test Specimen: Logistics Vehicle System Replacement (LVSR)

Payload: M1077 Flatrack Loaded with 155MM SLPs secured using 2-inch steel banding.

Testing Date: 18-23 October 2007

Gross Weight: 88,140 pounds (Including vehicle, ammunition and dunnage).

Payload Weight: 35,260 pounds



Photo 21. Flatrack Loaded with 155MM SLPs Secured with Steel Banding.

A. RAIL TEST.



Photo 22. Rail Impact Testing of the LVSR (Prior to Testing).

| Description | Weight |
|-------------------------------|--------------|
| Flatcar Number: DODX 42353 | 85,000 lbs. |
| LVSR | 88,140 lbs. |
| Total Specimen Wt. | 173,140 lbs. |
| Buffer Car (four cars) | 257,900 lbs. |

Figure 12.

Remarks:

1. Figure 12 lists the test components and weights of the items used during the Rail Impact Tests.
2. The LVSR was secured to the rail car in accordance with TEA Pamphlet (PAM) 55-19 "Tiedown Handbook for Rail Movements."
3. The flatrack was secured to the LVSR using the vehicle front twistlocks.
4. The LVSR suspension was set at highway pressure and the front lift adaptor (FLA) was stowed on the LVSR.

| Impact Number | Avg. Velocity (mph) |
|---------------|---------------------|
| 1 | 4.5 |
| 2 | 6.5 |
| 3 | 8.4 |
| 4 | 8.7 |

Figure 13.

Remarks:

1. Figure 13 lists the average speeds of the specimen car immediately prior to impact with the anvil. Impact #4 is the reverse impact.
2. Following Impact #1, the flatrack moved in the direction of impact 0.125 inches. The payload did not move.
3. Following Impact #2, the flatrack moved 0.25-0.5 inches in the direction of impact. The payload did not move.

4. Following Impact #4, the flatrack moved 1-1.25 inches in the direction of impact. The payload moved 0.5 inches in the direction of impact.
5. Inspection following each impact did not reveal any damage to the payload, flatrack, tiedowns, or LVSR.

B. ON/OFF ROAD TESTS.

1. HAZARD COURSE.



Photo 23. Hazard Course Testing of the LVSR.

| Pass No. | Elapsed Time | Avg. Velocity (mph) |
|-----------------|---------------------|----------------------------|
| 1 | 26.8 Seconds | 5.2 |
| 2 | 26.3 Seconds | 5.3 |

Figure 14.

Remarks:

1. Figure 14 lists the average speeds of the test load through the Hazard Course.
2. The flatrack moved side-to-side at the rear of the LVSR vehicle up to 1-inch during Passes 1 & 2.
3. Inspection following each pass did not reveal any damage to the payload, flatrack, or LVSR.

2. ROAD TRIP:

Remarks:

1. The Road Trip was conducted between the Road Hazard Course Passes #2 and #3.
2. Inspection following the Road Trip did not reveal any damage to the payload, flatrack, or LVSR.
3. The check fluids light came on and diagnostics showed that the transfer case fluid was low. Once the suspension was leveled and the vehicle warmed up, the light went off.

3. PANIC STOPS: Testing was not required since the load was rail impact tested.

4. HAZARD COURSE:

| Pass No. | Elapsed Time | Avg. Velocity (mph) |
|----------|--------------|---------------------|
| 3 | 25.9 Seconds | 5.4 |
| 4 | 24.7 Seconds | 5.6 |

Figure 15.

Remarks:

1. Figure 15 lists the average speeds of the test load through the Hazard Course.
2. The flatrack moved side-to-side at the rear of the LVSR vehicle up to 1-inch during Passes #3 & #4.
3. Inspection following each pass did not reveal any damage to the payload, flatrack, or LVSR.

5. WASHBOARD COURSE:

Remarks: Inspection following completion of the course did not reveal any damage to the payload, flatrack, or LVSR.



Photo 24. Washboard Course Testing of the LVSR

C. **OBSERVATION:** Final inspection prior to shipment revealed:

1. The flipper arm pins were bent.

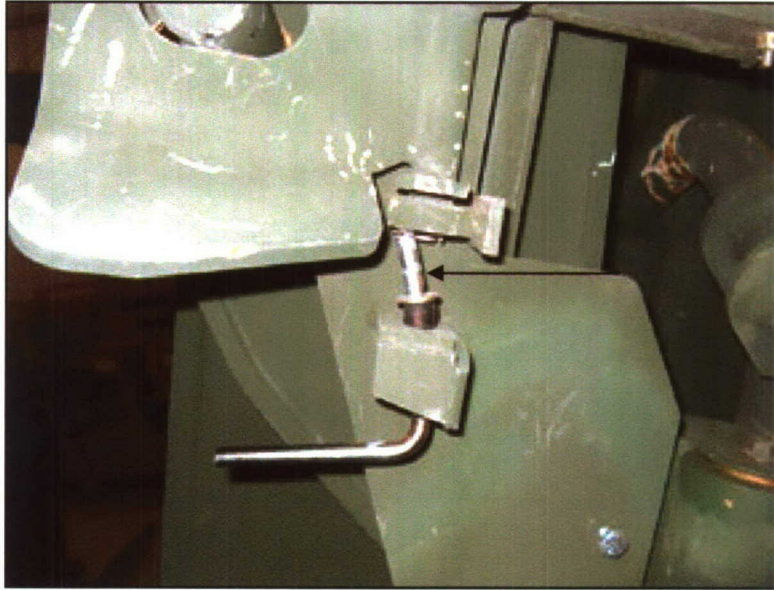

Photo 25. Bent Flipper Pin

2. The remote control would not operate.

3. Throughout testing, the vehicle leaked fluid from around the center of the front bumper. (See Photo 26). The center console was removed and the hoses and clamps were inspected. The blue hose in the center console was wet. The hose clamp was tightened and re-inspected and no additional leakage noted. Prior to and upon completion of testing water was added to the coolant system.



Photo 26. Coolant Leakage Point.

D. CONCLUSION: The LVSR, as currently designed, is adequate to transport M1077 flatracks by rail and on/off road when using 2-inch steel banding to secure the ammunition payload.

PART 6 – DRAWINGS

The following drawings represent the load configuration that was subjected to the test criteria. Modifications were made in the tie-down procedures in drawing 19-48 4903 during the testing identified in Section 5.1.

LOADING AND TIEDOWN PROCEDURES FOR CONVENTIONAL AMMUNITION ITEMS LOADED ON THE PALLETIZED LOADING SYSTEM (PLS) A-FRAME FLATRACK (M1077) AND/OR THE ISO COMPATIBLE PLS FLATRACK (IPF) (M1)

INDEX

| <u>ITEM</u> | <u>PAGE(S)</u> |
|-----------------------------------------------------|----------------|
| GENERAL NOTES AND MATERIAL SPECIFICATIONS - - - - - | 2 |
| ITEMIZED INDEX - - - - - | 3 |
| PALLETIZED UNITS (ONE HIGH) - - - - - | 4-25 |
| COMBAT CONFIGURED LOADS - - - - - | 6-15, 20-23 |
| PALLETIZED UNITS (TWO HIGH) - - - - - | 26-31 |
| LOOSE BOXES AND/OR CONTAINERS - - - - - | 32-41 |

U.S. ARMY MATERIEL COMMAND DRAWING

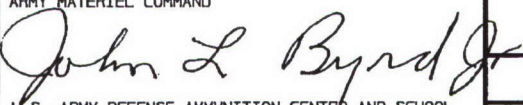
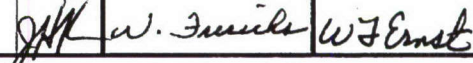
| | | | |
|--------------------------------------------------------------------------------------------------------------------------------------------------------------------|--------------------------------------------------------------------------------------------------------|-------------------------------------------|------------------------------------|
| APPROVED, U.S. ARMY ARMAMENT, MUNITIONS AND CHEMICAL COMMAND  | DRAFTSMAN | TECHNICIAN | ENGINEER |
| | B. LEONARD | | J. SIMONS |
| APPROVED BY ORDER OF COMMANDING GENERAL, U.S. ARMY MATERIEL COMMAND  | VALIDATION ENGINEERING DIVISION | TRANSPORTATION ENGINEERING DIVISION | LOGISTICS ENGINEERING OFFICE |
| U.S. ARMY DEFENSE AMMUNITION CENTER AND SCHOOL |  FEBRUARY 1994 | | |
| | CLASS | DIVISION | DRAWING |
| | 19 | 48 | 4903 |
| | | | FILE |
| | | | CA1704 |

DO NOT SCALE

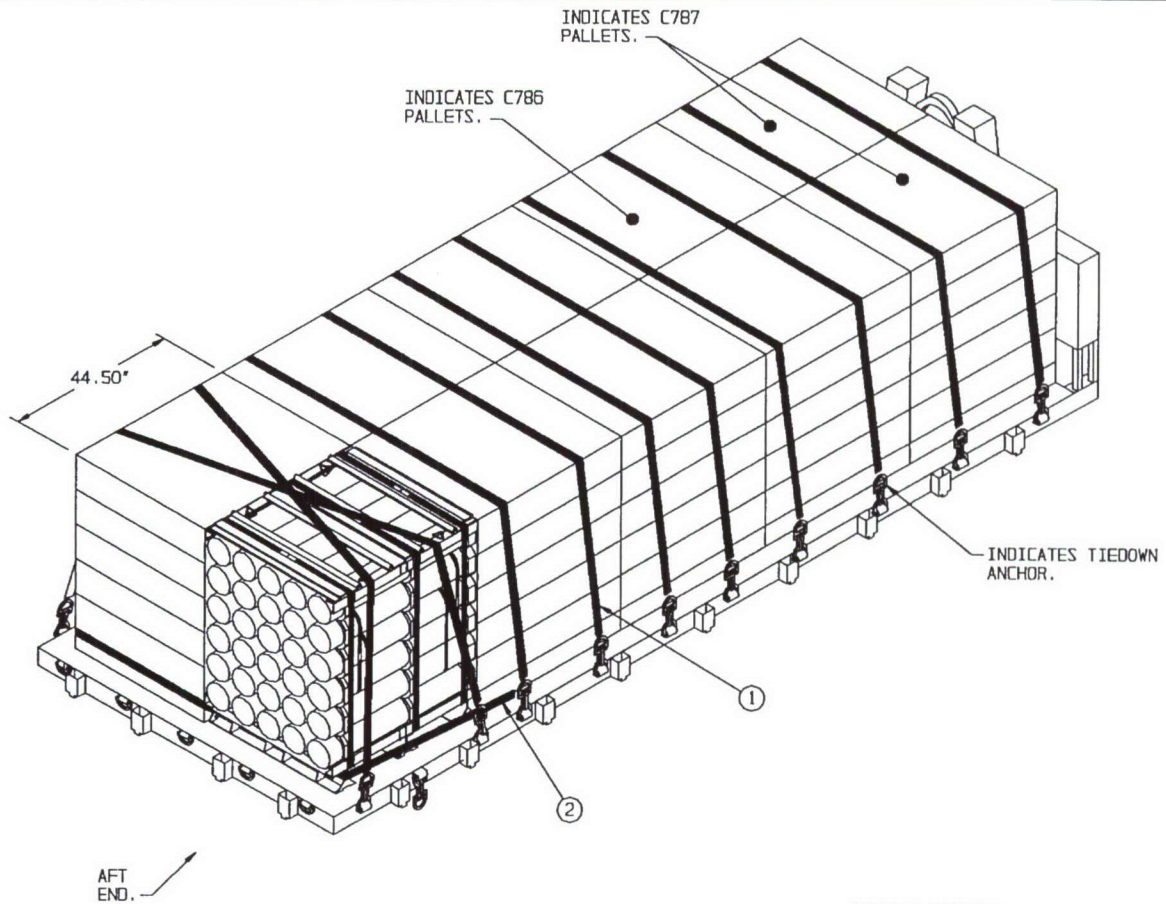

ISOMETRIC VIEW

KEY NUMBERS

- ① WEB STRAP TIEDOWN ASSEMBLY (10 REQD). INSTALL EACH STRAP TO EXTEND FROM A TIEDOWN ANCHOR ON SIDE OF FLATRACK, OVER TOP OF PALLET UNITS, TO A TIEDOWN ANCHOR ON OPPOSITE SIDE OF FLATRACK. POSITION STRAP SCUFF SLEEVES AT SHARP EDGES. TAKE UP EXCESS SLACK IN STRAP AND THEN RATCHET TIGHT. SEE GENERAL NOTES "F" AND "G" ON PAGE 2 AND SPECIAL NOTE 8 ON PAGE 7.
- ② WEB STRAP TIEDOWN ASSEMBLY (1 REQD). INSTALL STRAP TO EXTEND FROM A TIEDOWN ANCHOR ON SIDE OF FLATRACK, AROUND PALLET BASES OF REAR PALLETS, TO A TIEDOWN ANCHOR ON OPPOSITE SIDE OF FLATRACK. POSITION STRAP SCUFF SLEEVES AT SHARP EDGES. TAKE UP EXCESS SLACK IN STRAP AND THEN RATCHET TIGHT. SEE GENERAL NOTES "F" AND "G" ON PAGE 2.

| 120MM COMBAT CONFIGURED LOAD | | | | |
|------------------------------|--------------------------------------------------------|---------------|---------------|--------------|
| DODIC | ITEM | ITEM QUANTITY | LOAD QUANTITY | TOTAL WEIGHT |
| C786 | 120MM COMP RD APFSDS-T 39.50 L X 44.50 W X 51.50 H | 240 | 8 PALLETS | 19,128 LBS |
| C787 | 120MM COMP RD HEAT-MP-T 40.13 L X 44.50 W X 51.75 H | 60 | 2 PALLETS | 4,866 LBS |

SPECIAL NOTES:

1. A TYPICAL 120MM COMBAT CONFIGURED LOAD FOR ARMOR IS SHOWN LOADED ON THE A-FRAME FLATRACK HAVING CARGO DECK DIMENSIONS OF 7'-6-1/2" WIDE BY 19'-0" LONG AND A MAXIMUM LOAD WEIGHT OF 33,000 POUNDS.
2. IF LOADING AN M1 FLATRACK HAVING A CARGO DECK 18'-6" LONG, POSITION THE TWO REAR MOST PALLETS WITH THE 39.5" DIMENSION PARALLEL TO THE SIDE OF THE FLATRACK IN LIEU OF THE 44.5" DIMENSION. THIS WILL REDUCE THE LOAD LENGTH FROM 18'-6-1/2" LONG TO 18'-1-1/2" LONG. SEE GENERAL NOTE "C" ON PAGE 2.
3. IF FAST UNLOADING OF ROUNDS FROM THE PALLETIZED CONTAINERS IS DESIRED, USE THE PROCEDURES SHOWN FOR THE 105MM COMPLETE ROUNDS IN THE PA117 CONTAINER, ON PAGES 8 AND 9.
4. THE PALLETS SHOWN ARE TYPICAL ONLY. IF LOADING PALLETIZED UNITS OF OTHER ITEMS, SIZES, OR QUANTITIES, FOLLOW THESE SAME PROCEDURES.
5. PRIOR TO LOADING THE 120MM PALLETS ASSURE THAT ALL STEEL STRAPPING ON EACH PALLET IS IN POSITION AND IS TIGHT. MISSING AND/OR LOOSE STEEL STRAPPING SHOULD BE REPLACED.
6. WHEN LOADING THE FLATRACK POSITION THE LOAD TIGHT AGAINST THE A-FRAME AND CENTERED ACROSS THE WIDTH OF THE FLATRACK.
7. IF DESIRED, THE 120MM PALLETS MAY BE POSITIONED WITH THE 39.5" DIMENSION PARALLEL TO THE SIDES OF THE FLATRACK.
8. EACH LATERAL ROW OF TWO 120MM PALLETS MUST BE SECURED WITH TWO WEB STRAPS OVER THE TOP AS SHOWN. THESE TWO STRAPS MAY BE CROSSED AND/OR POSITIONED STRAIGHT ACROSS THE TOP OF A ROW.
9. ALL PALLETS MUST BE POSITIONED TIGHTLY AGAINST EACH OTHER Laterally AND LONGITUDINALLY. THIS WILL REDUCE LOAD MOVEMENT AND THE QUANTITY OF WEB STRAPS REQUIRED TO SECURE THE LOAD. VOID SPACES BETWEEN PALLET UNITS WILL FILL IN DURING TRANSPORT CAUSING WEB STRAPPING TO BECOME LOOSE.
10. A TOTAL OF ELEVEN WEB STRAP TIEDOWN ASSEMBLIES ARE REQUIRED FOR THE LOAD AS SHOWN.

LOAD AS SHOWN

| <u>ITEM</u> | <u>QUANTITY</u> | <u>WEIGHT (APPROX)</u> |
|------------------------|-----------------|------------------------|
| 120MM PALLET - - - - - | 10 - - - - - | 23,994 LBS |

120MM COMBAT CONFIGURED LOAD FOR ARMOR

PAGE 7

PROJECT CAP-TV 4-93

APPROVED BY
BUREAU OF EXPLOSIVES

DLH

DATE 3/04/01

APPENDIX 102

LOADING AND BRACING PROCEDURES FOR AMMUNITION LOADED ON CONTAINER ROLL IN/OUT PLATFORM (CROP)

SEPARATE LOADING PROJECTILES PALLETIZED
ON WOODEN AND METAL PALLETS; INCLUDES
LARGE & SMALL PALLET UNIT CONFIGURATIONS

INDEX

| <u>ITEM</u> | <u>PAGE(S)</u> |
|--------------------------------------|----------------|
| TYPICAL LOADING PROCEDURES - - - - - | 2 |
| GENERAL NOTES - - - - - | 3 |
| PALLET UNIT DETAILS - - - - - | 4 |
| DETAILS - - - - - | 5 |

NOTICE: THIS APPENDIX CANNOT STAND ALONE BUT MUST BE USED IN CONJUNCTION WITH THE BASIC CROP OUTLOADING PROCEDURES DRAWING 19-48-4906-CA17Q7.

- LOADING AND BRACING SPECIFICATIONS SET FORTH WITHIN THIS DRAWING ARE APPLICABLE TO LOADS THAT ARE TO BE SHIPPED BY TRAILER/CONTAINER-ON-FLATCAR (T/COFC) RAIL CARRIER SERVICE. THESE SPECIFICATIONS MAY ALSO BE USED FOR LOADS THAT ARE TO BE MOVED BY MOTOR OR WATER CARRIERS.

U.S. ARMY MATERIEL COMMAND DRAWING

| | | | | | | | | | |
|--------------------------------------------------------------------------------------------------------------------------------------------|-------------------------------------------|-------|---------------|-------------------------|------------------------------------------------------------------------|-------|----------|--------------|--------|
| APPROVED, U.S. ARMY OPERATIONS SUPPORT COMMAND <i>Timothy R. Fore</i> | ENGINEER | BASIC | WALTER GORDON | | DO NOT SCALE | | | | |
| | | REV. | | | WEBSITE: HTTP://WWW.DAC.ARMY.MIL | | | | |
| | TECHNICIAN | BASIC | | | JANUARY 2001 | | | | |
| | REV. | | | | | | | | |
| APPROVED BY ORDER OF COMMANDING GENERAL, U.S. ARMY MATERIEL COMMAND <i>J.P. White</i> U.S. ARMY DEFENSE AMMUNITION CENTER | DRAFTSMAN | BASIC | | | | | | | |
| | | REV. | | | | | | | |
| | TRANSPORTATION ENGINEERING DIVISION | | | <i>Klaus G. Feiffer</i> | | | | | |
| | VALIDATION ENGINEERING DIVISION | | | <i>James W. ...</i> | TESTED | CLASS | DIVISION | DRAWING | FILE |
| | ENGINEERING DIRECTORATE | | | <i>William R. ...</i> | | 19 | 48 | 4906/ 102 | CA17Q7 |

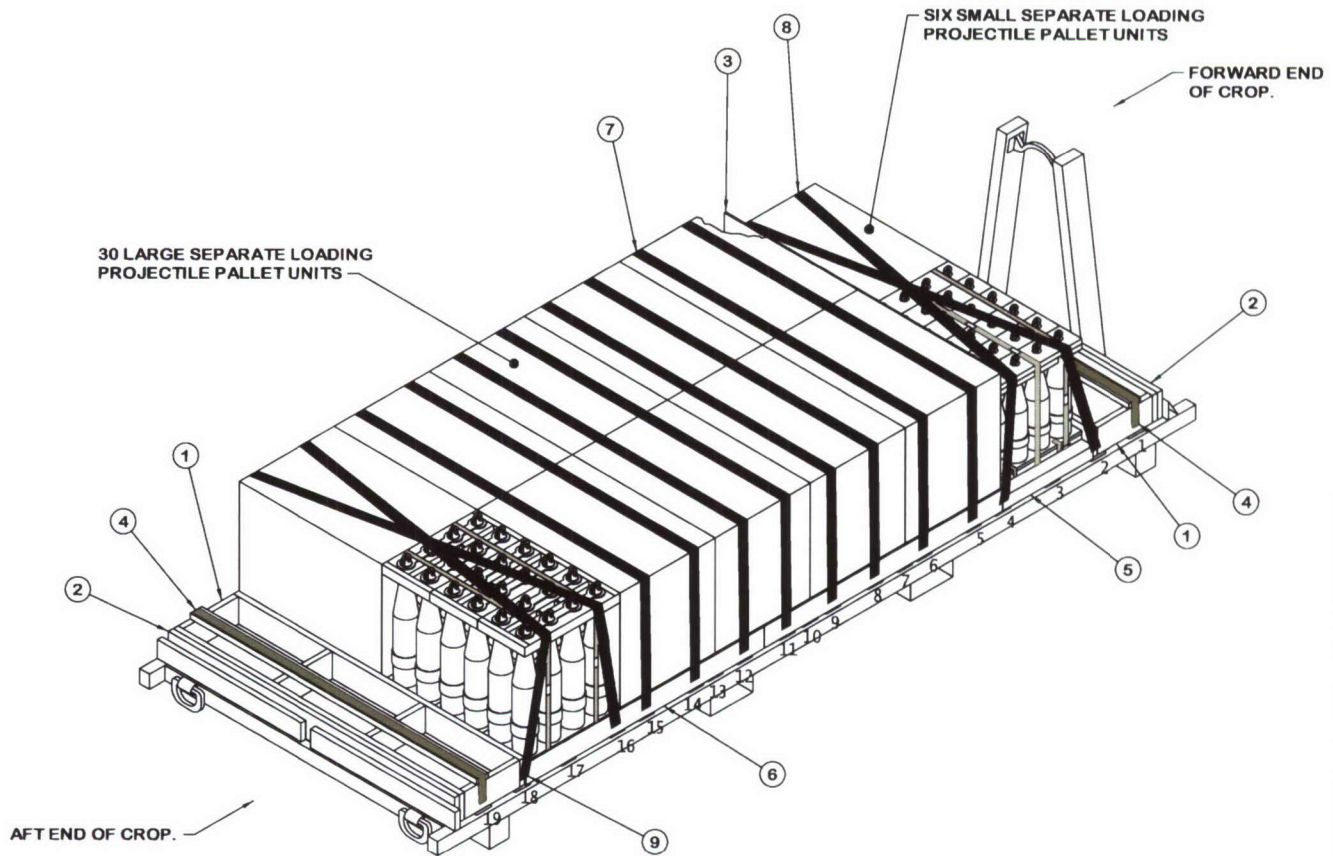

ISOMETRIC VIEW

NOTE: PALLET UNITS SHOWN ARE BUNDLED WITH THREE PALLET UNITS PER BUNDLE; HOWEVER, PALLET UNITS ARE NOT REQUIRED TO BE BUNDLED.

(KEY NUMBERS CONTINUED)

- 7 HOLD-DOWN STRAP, 3-INCH WIDE WEB STRAP TIEDOWN ASSEMBLY FOR CROP (8 REQD). INSTALL EACH HOLD-DOWN STRAP TO EXTEND FROM THE DESIGNATED TIEDOWN ANCHOR ON ONE SIDE OF CROP, OVER TOP OF PALLET UNITS, TO CORRESPONDING TIEDOWN ANCHOR ON OPPOSITE SIDE OF CROP. ALIGN SCUFF SLEEVES OVER ALL SHARP EDGES AND FIRMLY TENSION STRAP. SEE GENERAL NOTES "F" AND "H" ON PAGE 3.
- 8 FORWARD HOLD-DOWN STRAP, 3-INCH WIDE WEB STRAP TIEDOWN ASSEMBLY FOR CROP (2 REQD). INSTALL EACH STRAP FROM THE SECOND TIEDOWN ANCHOR ON ONE SIDE OF THE CROP (ONE ON EACH SIDE), OVER THE TOP OF THE PALLET UNITS AND BACK DOWN TO THE FOURTH TIEDOWN ANCHOR ON THE OPPOSITE SIDE OF THE CROP. ALIGN SCUFF SLEEVES OVER ALL SHARP EDGES AND FIRMLY TENSION STRAP. SEE GENERAL NOTES "F" AND "H" ON PAGE 3.
- 9 AFT HOLD-DOWN STRAP, 3-INCH WIDE WEB STRAP TIEDOWN ASSEMBLY FOR CROP (2 REQD). INSTALL EACH STRAP FROM THE EIGHTEENTH TIEDOWN ANCHOR ON ONE SIDE OF THE CROP (ONE ON EACH SIDE), OVER THE TOP OF THE PALLET UNITS AND BACK DOWN TO THE SIXTEENTH TIEDOWN ANCHOR ON THE OPPOSITE SIDE OF THE CROP. ALIGN SCUFF SLEEVES OVER ALL SHARP EDGES AND FIRMLY TENSION STRAP. SEE GENERAL NOTES "F" AND "H" ON PAGE 3.

KEY NUMBERS

- 1 END BLOCKING ASSEMBLY (2 REQD). SEE THE DETAIL ON PAGE 5. CENTER ON DECK OF CROP AND ENSURE STRAPPING BOARD IS IN LINE WITH ANCHOR. SEE GENERAL NOTE "B" ON PAGE 3.
- 2 FILL PIECE, 1" OR 2" X 8" X 7'-4" (2 REQD). NAIL TO AN END BLOCKING ASSEMBLY W/8 EVENLY SPACED NAILS OF A SUITABLE SIZE (6d FOR 1" THICK MATERIAL AND 10d FOR 2" THICK MATERIAL). ONE FILL PIECE MAY BE PREFABRICATED WITH AN END BLOCKING ASSEMBLY.
- 3 SEPARATOR ASSEMBLY (1 REQD). SEE THE DETAIL ON PAGE 5. INSTALL BETWEEN THE LARGE AND SMALL PALLET UNITS.
- 4 RETAINER STRAP, 2-INCH WIDE WEB STRAP TIEDOWN ASSEMBLY (2 REQD). INSTALL TO EXTEND FROM A TIEDOWN RING ON SIDE OF CROP, OVER TOP OF STRAPPING BOARD OF END BLOCKING ASSEMBLY, TO CORRESPONDING TIEDOWN RING ON OPPOSITE SIDE OF CROP. POSITION STRAP SCUFF SLEEVES AT SHARP EDGES. TAKE UP EXCESS SLACK IN STRAP AND THEN RATCHET TIGHT. SEE GENERAL NOTE "F" ON PAGE 3.
- 5 SIDE FILL PIECE A, 4" X 4" X 27'-1/2" (2 REQD). INSTALL ONE PIECE ON EACH SIDE OF CROP ADJACENT TO THE SMALL PALLET UNITS. SEE GENERAL NOTE "G" ON PAGE 3.
- 6 SIDE FILL PIECE B, 5-3/4" X 6'-1" X 1/2" THICK PLYWOOD (4 REQD). INSTALL TWO PIECES ON EACH SIDE OF CROP ADJACENT TO THE LARGE PALLET UNITS. SEE GENERAL NOTE "G" ON PAGE 3.

(CONTINUED AT LEFT)

GENERAL NOTES

- A. THIS APPENDIX CANNOT STAND ALONE BUT MUST BE USED IN CONJUNCTION WITH THE BASIC LOADING PROCEDURES DRAWING 19-48-4906-CA17Q7. TO PRODUCE AN APPROVED LOAD, ALL PERTINENT PROCEDURES, SPECIFICATIONS AND CRITERIA SET FORTH WITHIN THE BASIC DRAWING WILL APPLY TO THE PROCEDURES DELINEATED IN THIS APPENDIX. ANY EXCEPTIONS TO THE BASIC PROCEDURES ARE SPECIFIED IN THIS APPENDIX.
- B. THE OUTLOADING PROCEDURES DEPICTED IN THIS DRAWING ARE APPLICABLE TO LOADS OF 36 PALLET UNITS OF PROJECTILES. SEE PAGE 4 FOR DETAILS OF THE TYPICAL PALLET UNITS. AN M3 (SUMMA) CROP IS SHOWN AS TYPICAL. OTHER MANUFACTURER'S CROPS CAN BE USED FOR THE LOAD SHOWN ON PAGE 2. THE AFT AND FORWARD END BLOCKING ASSEMBLIES OR PIECES MUST BE RESTRAINED FROM MOVING IN BOTH THE LATERAL AND VERTICAL DIRECTIONS. THIS IS ACCOMPLISHED IN THE LOAD SHOWN ON PAGE 2 WITH A 2" WEB STRAP TIEDOWN ASSEMBLY. IF THE CONFIGURATION OF A CROP IS SUCH THAT VERTICAL OR LATERAL RESTRAINT CANNOT BE PROVIDED, ADDITIONAL RESTRAINT METHODS, TO INCLUDE HOLD DOWN PIECES, RETAINING NAILS, AND/OR 2" WIDE WEB STRAP TIEDOWN ASSEMBLIES MUST BE INSTALLED.
- C. THE LOADING PROCEDURES DEPICTED HEREIN MAY BE USED FOR OUTLOADING PALLET UNITS WITH DIMENSIONS OTHER THAN WHAT IS SHOWN ON PAGE 4, PROVIDED THE OVERALL PALLET UNIT DIMENSIONS RESULT IN A LOAD THAT IS CONTAINED WITHIN AN ENVELOPE OF 211" L X 89" W X 73-1/2" H.
- D. DIMENSIONS, CUBE AND WEIGHT OF THE PALLET UNITS WILL VARY SLIGHTLY DEPENDING UPON THE ACTUAL DIMENSIONS OF THE PROJECTILES AND THE WEIGHT OF THE SPECIFIC ITEM BEING UNITIZED.
- E. DIMENSIONS GIVEN FOR DUNNAGE ASSEMBLIES WILL BE FIELD CHECKED PRIOR TO THEIR ASSEMBLY. PALLET UNITS MUST FIT SNUGLY AGAINST THE DUNNAGE ASSEMBLIES. THIS GUIDANCE MUST BE APPLIED PRIOR TO BEGINNING AN OUTLOADING OPERATION. ALSO, DUE TO VARIATION OF PALLET UNIT DIMENSIONS, ADJUSTMENTS MAY BE REQUIRED AS TO THE LOCATION OF CERTAIN PIECES ON DUNNAGE ASSEMBLIES.
- F. ALL WEB STRAP TIEDOWN ASSEMBLIES MUST HAVE THE EXCESS LENGTH OF THE STRAP SECURED. ROLL UP AND BUNDLE THE EXCESS LENGTH OF WEB STRAP, SECURING WITH CABLE TIES. SEE THE "STRAP END SECUREMENT" DETAIL AND GENERAL NOTE "K.12" IN THE BASIC PROCEDURE DRAWING 19-48-4906-CA17Q7.
- G. EACH END OF THE SIDE FILL PIECES MUST BE SECURED BY NAILING A 10d NAIL THRU A 3" WEBSTRAP HOOK SLOT. SEE "STRAP HOOK DETAIL" AND GENERAL NOTE "G.2" IN THE BASIC PROCEDURES DRAWING 19-48-4906-CA17Q7.
- H. UNUSED WEB STRAP TIEDOWN ASSEMBLIES MUST BE SECURED AS DELINEATED IN GENERAL NOTE "K.13" IN THE BASIC PROCEDURE DRAWING 19-48-4906-CA17Q7.
- J. CONVERSION TO METRIC EQUIVALENTS: DIMENSIONS WITHIN THIS DOCUMENT ARE EXPRESSED IN INCHES, AND WEIGHTS ARE EXPRESSED IN POUNDS. WHEN NECESSARY, THE METRIC EQUIVALENTS MAY BE COMPUTED ON THE BASIS OF ONE INCH EQUALS 25.4MM AND ONE POUND EQUALS 0.454 KG.

BILL OF MATERIAL

| LUMBER | LINEAR FEET | BOARD FEET |
|----------------------------------------|--------------------------|------------|
| 2" X 4" | 15 | 10 |
| 2" X 8" | 55 | 74 |
| 4" X 4" | 5 | 6 |
| NAILS | NO. REQD | POUNDS |
| 6d (2") | 6 | NIL |
| 10d (3") | 80 | 1-1/4 |
| PLYWOOD, 1/2" - - - - | 31.91 SQ FT REQD - - - - | 43.88 LBS |
| 2" WEBSTRAP TIEDOWN ASSEMBLY - - - - - | 2 REQD - - - - - | 11 LBS |

LOAD AS SHOWN

| ITEM | QUANTITY | WEIGHT (APPROX) |
|-------------------------------|------------|----------------------------|
| SMALL SLP PALLET UNIT - - - | 6 - - - - | 5,382 LBS |
| LARGE SLP PALLET UNIT - - - | 30 - - - - | 24,900 LBS |
| DUNNAGE - - - - - | - - - - - | 237 LBS |
| CROP - - - - - | - - - - - | 3,800 LBS |
| TOTAL WEIGHT - - - - - | | 34,319 LBS (APPROX) |

LARGE SEPARATE LOADING PROJECTILE PALLET UNIT DETAIL

| | | |
|----------------------------|-------|--------------------|
| 8 155MM CTG AT 102-3/4 LBS | ----- | 822 LBS (APPROX) |
| DUNNAGE AND PALLET | ----- | 75 LBS |
| <hr/> | | |
| TOTAL WEIGHT | ----- | 897 LBS (APPROX) |
| CUBE | ----- | 9.6 CU FT (APPROX) |

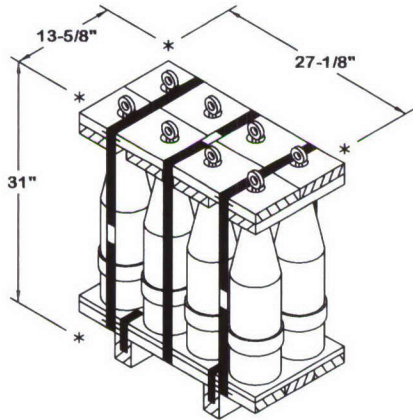
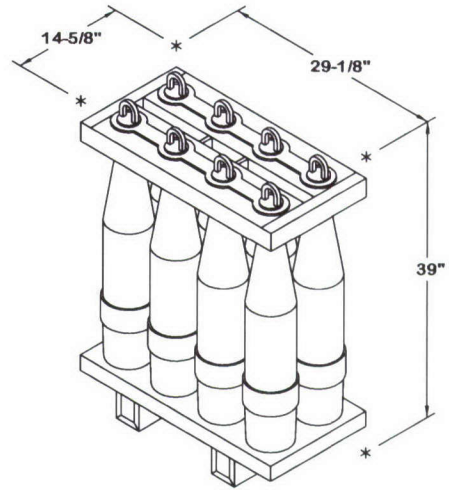

SMALL SEPARATE LOADING PROJECTILE PALLET UNIT DETAIL

| | | |
|---------------------------|-------|--------------------|
| 8 155MM CTG AT 98-1/2 LBS | ----- | 788 LBS (APPROX) |
| DUNNAGE AND PALLET | ----- | 42 LBS |
| <hr/> | | |
| TOTAL WEIGHT | ----- | 830 LBS (APPROX) |
| CUBE | ----- | 6.6 CU FT (APPROX) |

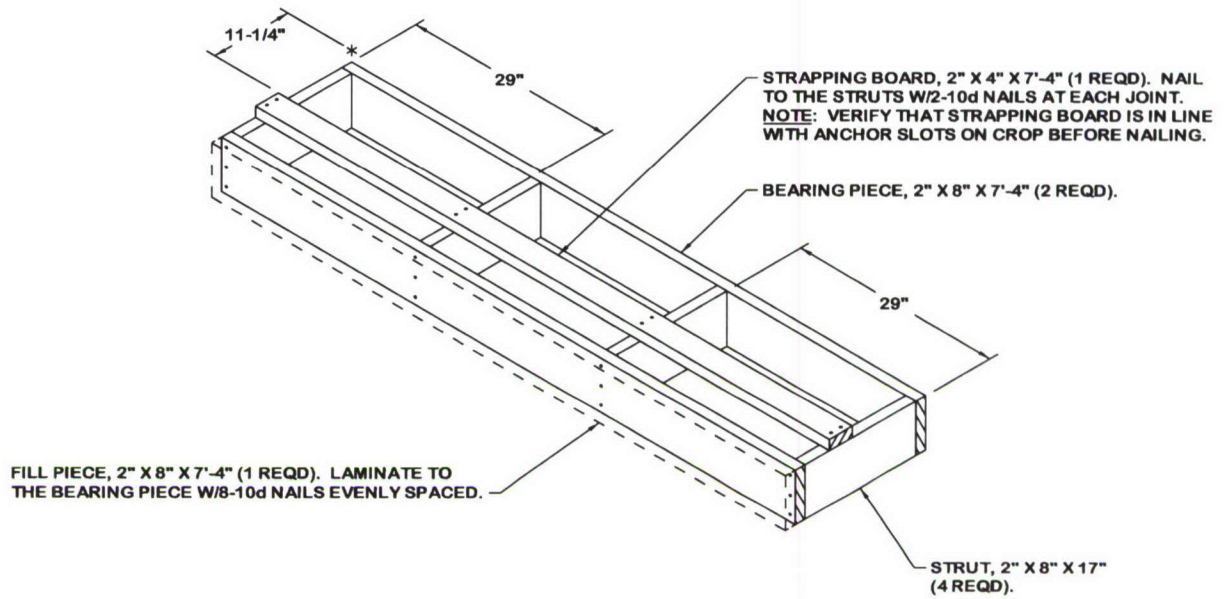

END BLOCKING ASSEMBLY

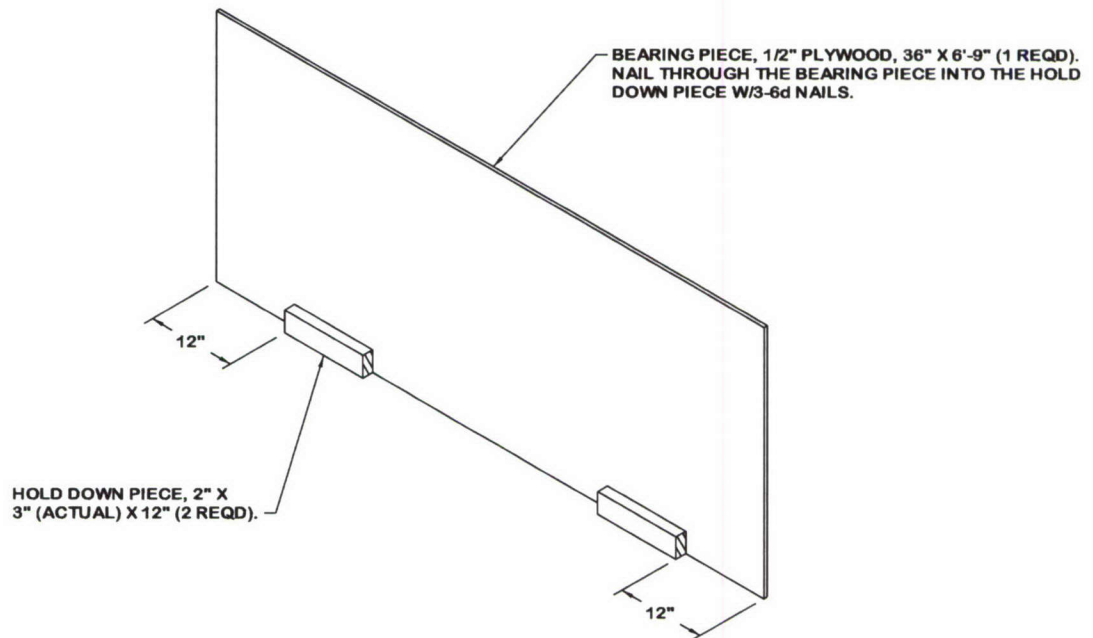

SEPARATOR ASSEMBLY

LOADING AND TIEDOWN PROCEDURES FOR CONVENTIONAL AMMUNITION ITEMS LOADED ON THE PALLETIZED LOADING SYSTEM (PLS) A-FRAME FLATRACK (M1077), AND/OR THE ISO COMPATIBLE PLS FLATRACK (IPF) (M1), FOR RAPID DEPLOYMENT BY RAIL AND SHIP

INDEX

| ITEM | PAGE(S) |
|-------------------------------------------|---------|
| GENERAL NOTES AND MATERIAL SPECIFICATIONS | 2 |
| LOADING PROCEDURES AND ITEMIZED INDEX | 3 |
| LOADS ON M1 FLATRACK | 4-21 |
| LOADS ON A-FRAME FLATRACK | 22-35 |
| DETAILS | 36-58 |

- THE PROCEDURES DEPICTED WITHIN THIS DRAWING ARE FOR TRANSPORTING CONVENTIONAL AMMUNITION ITEMS LOADED ON THE PALLETIZED LOADING SYSTEM (PLS) A-FRAME AND/OR M1 FLATRACKS, BY RAIL AND/OR SHIP. HOWEVER, THEY MAY ALSO BE USED FOR ON AND/OR OFF HIGHWAY MOVEMENT, IF DESIRED.

| DEPARTMENT OF ARMY DRAWING | | | |
|----------------------------|--------------------------------------------------------------------------|-------------------------------------------|------------------------------------|
| | DRAFTSMAN | TECHNICIAN | ENGINEER |
| | B. LEONARD | | J. SIMONS |
| | VALIDATION ENGINEERING DIVISION | TRANSPORTATION ENGINEERING DIVISION | LOGISTICS ENGINEERING OFFICE |
| OCTOBER 1994 | <i>W. F. Ernst</i> | | |
| DRAWING NUMBER | APPROVED BY ORDER OF COMMANDING GENERAL, U.S. ARMY MATERIEL COMMAND | | |
| DA-114 | <i>William F Ernst</i> U.S. ARMY DEFENSE AMMUNITION CENTER AND SCHOOL | | |

DO NOT SCALE

(KEY NUMBERS CONTINUED)

- 11 LOAD RETAINING STRAP, 2" X .044" OR .050" BY LENGTH-TO-SUIT STEEL STRAPPING (1 REQD). INSTALL IN TWO PIECES WITH ONE END OF EACH PIECE ATTACHED TO A FLATRACK TIEDOWN ANCHOR AT LOCATION SHOWN. BRING LOOSE ENDS AT AN ANGLE UP AND AROUND THE TOP STRAPPING BOARD ON CENTER GATE ASSEMBLY P. POSITION STRAP ON THE BEVELED SURFACE AND SEAL WITH TWO SEALS MARKED 21. SECURE IN PLACE BY DRIVING 10d NAILS INTO THE STRAPPING BOARD ON EACH SIDE OF THE STRAP AND BENDING OVER STRAP. STAPLES MAY BE USED IF AVAILABLE. SEE GENERAL NOTE "L" ON PAGE 2 AND THE HOLD-DOWN STRAP THREADING DETAIL ON PAGE 56.

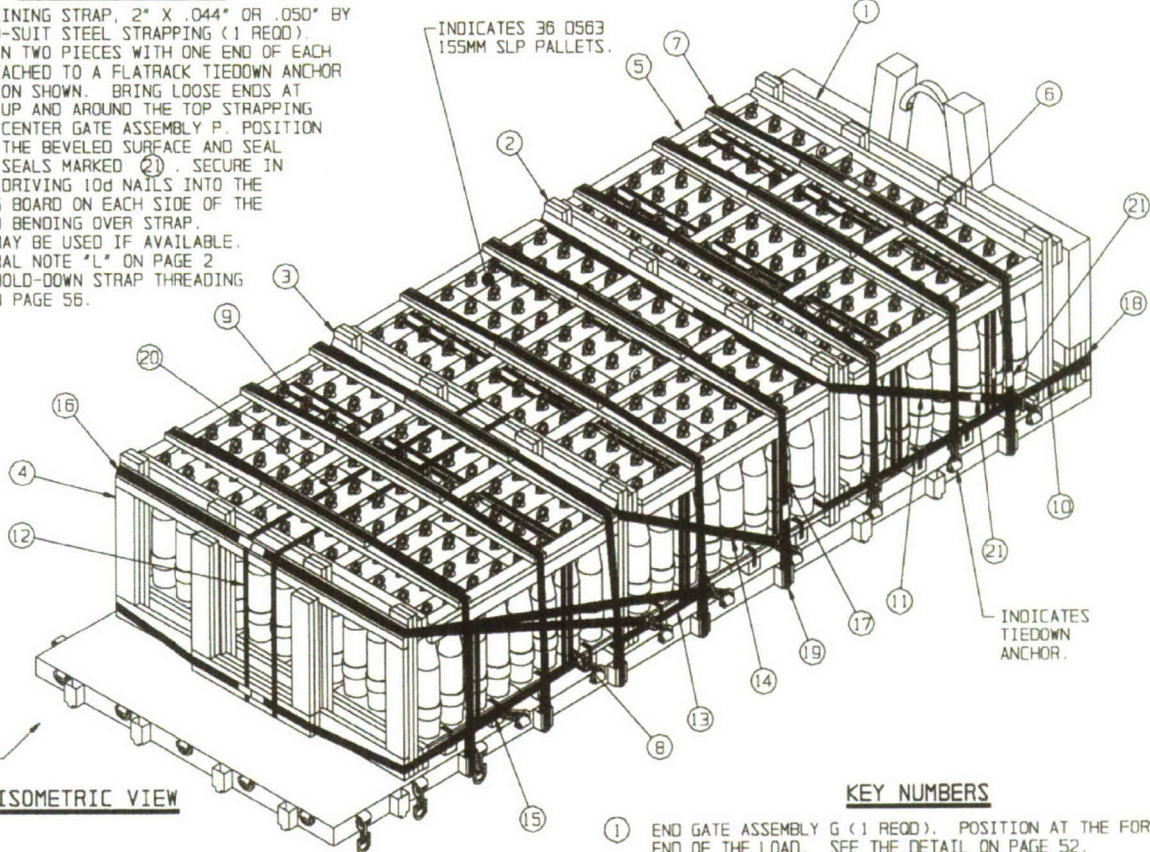

ISOMETRIC VIEW

KEY NUMBERS

- 1 END GATE ASSEMBLY G (1 REQD). POSITION AT THE FORWARD END OF THE LOAD. SEE THE DETAIL ON PAGE 52.
- 2 CENTER GATE ASSEMBLY P (1 REQD). POSITION BETWEEN PALLETS AT LOCATION SHOWN. SEE THE DETAIL ON PAGE 43.
- 3 CENTER GATE ASSEMBLY Q (1 REQD). POSITION BETWEEN PALLETS AT LOCATION SHOWN. SEE THE DETAIL ON PAGE 43, AND SPECIAL NOTE 7 ON PAGE 29.
- 4 END GATE ASSEMBLY H (1 REQD). POSITION AT AFT END OF LOAD. SEE THE DETAIL ON PAGE 52.
- 5 HOLD-DOWN ASSEMBLY B (6 REQD). POSITION ON TOP OF THE PALLETS AS SHOWN. SEE THE DETAIL ON PAGE 46.
- 6 HOLD-DOWN, 2" X 4" X 58" (6 REQD). POSITION ON JOINTS BETWEEN PALLETS AT LOCATIONS SHOWN.
- 7 STRAPPING BOARD ASSEMBLY A (6 REQD). POSITION AT THE LOCATIONS SHOWN AND NAIL TO THE HOLD-DOWN PIECES MARKED 6 W/2-10d NAILS EACH JOINT. SEE THE DETAIL ON PAGE 44.
- 8 UNITIZING STRAP, 1-1/4" X .035" OR .031" BY LENGTH-TO-SUIT STEEL STRAPPING (12 REQD). INSTALL EACH STRAP TO ENCIRCLE THREE LATERALLY ADJACENT PALLET UNITS UNDER THE SKID BASE AND OVER TOP OF COVER. THESE STRAPS MAY BE POSITIONED PRIOR TO LOADING PALLETS ON THE FLATRACK. SEAL WITH ONE SEAL MARKED 20. SEE GENERAL NOTE "M" ON PAGE 2.
- 9 BUNDLING STRAP, 1-1/4" X .035" OR .031" BY LENGTH REQUIRED TO ENCIRCLE SIX LATERALLY ADJACENT PALLET UNITS UNDER THE SKID BASE AND OVER TOP OF COVER (6 REQD). POSITION STRAPS AT CENTER OF PALLETS. SEAL WITH ONE SEAL MARKED 20. SEE GENERAL NOTE "M" ON PAGE 2.
- 10 LOAD RETAINING STRAP, 2" X .044" OR .050" BY LENGTH-TO-SUIT STEEL STRAPPING (1 REQD). INSTALL IN TWO PIECES WITH ONE END OF EACH PIECE ENCIRCLING THE STEEL FRAME ON EACH SIDE OF THE A-FRAME, APPROXIMATELY 7" ABOVE THE FLOOR. BRING LOOSE ENDS AROUND THE BOTTOM STRAPPING BOARD ON CENTER GATE ASSEMBLY P. SEAL WITH TWO SEALS MARKED 21. SECURE IN PLACE BY DRIVING 10d NAILS INTO THE STRAPPING BOARD ON EACH SIDE OF THE STRAP AND BENDING OVER STRAP. STAPLES MAY BE USED IF AVAILABLE. SEE GENERAL NOTE "L" ON PAGE 2.

(KEY NUMBERS CONTINUED)

- 12 BUNDLING STRAP, 1-1/4" X .035" OR .031" BY LENGTH-TO-SUIT STEEL STRAPPING (2 REQD). INSTALL EACH STRAP TO ENCIRCLE TWO LONGITUDINALLY ADJACENT PALLET UNITS. CENTER GATE ASSEMBLY Q, AND END GATE ASSEMBLY H. POSITION STRAPS AROUND CENTERS OF THE THIRD PALLET FROM EACH SIDE, UNDER SKIDS AND OVER TOP OF COVER. PRE-POSITION STRAPS ON FLOOR OF FLATRACK PRIOR TO LOADING THE TWELVE PALLET UNITS AT THE AFT END. POSITION STRAPS UNDER THE STRAPPING BOARDS MARKED 7 AND SEAL WITH ONE SEAL MARKED 20. SEE SPECIAL NOTE 7 ON PAGE 29 AND GENERAL NOTE "M" ON PAGE 2.
- 13 LOAD RETAINING STRAP, 2" X .044" OR .050" BY LENGTH-TO-SUIT STEEL STRAPPING (1 REQD). INSTALL STRAP IN TWO PIECES WITH ONE END OF EACH PIECE ATTACHED TO A FLATRACK TIEDOWN ANCHOR AT LOCATION SHOWN. BRING LOOSE ENDS AROUND THE BOTTOM STRAPPING BOARD ON CENTER GATE ASSEMBLY Q AND SEAL WITH TWO SEALS MARKED 21. SECURE IN PLACE BY DRIVING 10d NAILS INTO THE STRAPPING BOARD ON EACH SIDE OF THE STRAP AND BENDING OVER STRAP. STAPLES MAY BE USED IF AVAILABLE. SEE SPECIAL NOTE 7 ON PAGE 29 AND GENERAL NOTE "L" ON PAGE 2.
- 14 LOAD RETAINING STRAP, 2" X .044" OR .050" BY LENGTH-TO-SUIT STEEL STRAPPING (1 REQD). INSTALL IN TWO PIECES WITH ONE END OF EACH PIECE ATTACHED TO A FLATRACK TIEDOWN ANCHOR AT LOCATION SHOWN. BRING LOOSE ENDS AT AN ANGLE UP AND AROUND THE TOP STRAPPING BOARD ON CENTER GATE ASSEMBLY Q. POSITION STRAP ON THE BEVELED SURFACE AND SEAL WITH TWO SEALS MARKED 21. SECURE IN PLACE BY DRIVING 10d NAILS INTO THE STRAPPING BOARD ON EACH SIDE OF THE STRAP AND BENDING OVER STRAP. STAPLES MAY BE USED IF AVAILABLE. SEE SPECIAL NOTE 7 ON PAGE 29 AND GENERAL NOTE "L" ON PAGE 2 AND THE STRAP THREADING DETAIL ON PAGE 56.

(KEY NUMBERS CONTINUED ON PAGE 29)

| 120MM COMPLETE ROUND CONFIGURED LOAD | | | | |
|--------------------------------------|----------------------------------------------------------|---------------|---------------|--------------|
| DDDIC | ITEM | ITEM QUANTITY | LOAD QUANTITY | TOTAL WEIGHT |
| 0563 | PROJ. 155MM, M483A1 DPICM 14.62 L X 29.12 W X 39.38 H | 288 | 36 PALLETS | 31,464 LBS |

155MM SEPARATE LOADING PROJECTILES

(CONTINUED AT LEFT)

SPECIAL NOTES:

1. A TYPICAL LOAD OF 36 PALLETS OF 155MM SEPARATE LOADING PROJECTILES IS SHOWN LOADED ON THE 16-1/2-TON M1077 FLATRACK HAVING CARGO DECK DIMENSIONS OF 7'-6-1/2" WIDE BY 19'-0" LONG AND A MAXIMUM LOAD WEIGHT OF 33,000 POUNDS.
2. THE 155MM SLP (D563) EIGHT PROJECTILE PALLET HAVING DIMENSIONS OF 29-1/8" WIDE BY 14-5/8" LONG BY 39-3/8" HIGH AND WEIGHING 874 POUNDS IS SHOWN AS TYPICAL. IF LOADING SEPARATE LOADING PROJECTILES OF OTHER QUANTITIES, DIMENSIONS, AND WEIGHT, FOLLOW THESE SAME PROCEDURES AS CLOSELY AS POSSIBLE.
3. PRIOR TO LOADING THE SLP PALLETS, ASSURE THAT ALL STEEL STRAPPING ON EACH PALLET IS IN POSITION AND IS TIGHT. MISSING AND/OR LOOSE STEEL STRAPPING SHOULD BE REPLACED.
4. DUE TO WEIGHT, HIGH CENTER OF GRAVITY, AND SMALL SKID AREA CONTACTING THE STEEL FLOOR, LOADS OF SEPARATE LOADING PROJECTILES MUST BE DIVIDED INTO SECTIONS WHICH MUST NOT EXCEED 11,000 POUNDS. EACH SECTION MUST BE SECURED WITH A GATE AND STEEL STRAPPING AS SHOWN IN THE LOAD ON PAGE 28. NOTE THAT THE 36 PALLETS SHOWN IN THE LOAD ON PAGE 28 HAVE A TOTAL WEIGHT OF 31,464 POUNDS. THEREFORE, THE LOAD WAS DIVIDED INTO THREE SECTIONS WEIGHING 10,488 POUNDS EACH.
5. POSITION THE LOAD TIGHT AGAINST THE A-FRAME AT THE FORWARD END OF THE FLATRACK. ALL PALLET UNITS MUST BE POSITIONED TIGHTLY AGAINST EACH OTHER Laterally AND LONGITUDINALLY TO REDUCE LOAD MOVEMENT AND ASSURE A TIGHT LOAD AFTER HOLD-DOWN STEEL STRAPPING IS IN POSITION.
6. FOR EASE OF LOADING AND SECUREMENT OF THE LOAD, EACH ROW OF SEPARATE LOADING PROJECTILES POSITIONED ACROSS THE WIDTH OF THE FLATRACK MUST CONTAIN THE SAME QUANTITY. USE AN "OMITTED SLP PALLETIZED UNIT ASSEMBLY" FOR EACH OMITTED UNIT AS NECESSARY TO MAINTAIN ROWS. SEE THE "OMITTED SLP PALLETIZED UNIT ASSEMBLY" DETAIL ON PAGE 58.
7. STRAPS MARKED ⑫ MUST BE PRE-POSITIONED ON THE FLOOR OF FLATRACK AND AROUND CENTER GATE ASSEMBLY Q PRIOR TO INSTALLING STRAPS MARKED ⑬ AND ⑭, AND THE LAST TWO ROWS OF SEPARATE LOADING PROJECTILE PALLETS. POSITION STRAPS MARKED ⑫ TO CENTER ON THE THIRD PALLET FROM EACH SIDE OF THE FLATRACK. STRAPS MARKED ⑫ ARE REQUIRED TO HELP RETAIN THE CENTER ROWS OF PALLETS DURING END IMPACT.
8. TWO LOAD RETAINING STRAPS MARKED ⑮ AND TWO LOAD RETAINING STRAPS MARKED ⑯ ARE REQUIRED AT THE AFT END OF THE LOAD DUE TO THE MAXIMUM LOAD WEIGHT AND SMALL SKID AREA OF THE 155MM SLP PALLETS.
9. FOR THE SAME ITEM ON THE M1 FLATRACK SEE PAGES 16 AND 17.

(KEY NUMBERS CONTINUED)

- ⑮ LOAD RETAINING STRAP, 2" X .044" OR .050" BY LENGTH-TO-SUIT STEEL STRAPPING (2 RECD). INSTALL EACH STRAP IN TWO PIECES WITH ONE END OF EACH PIECE ATTACHED TO A FLATRACK TIEDOWN ANCHOR AT LOCATIONS SHOWN. INSTALL THE SHORTEST STRAPS FIRST THEN THE LONGER STRAPS OVER TOP OF SHORT STRAPS AND TO DIFFERENT TIEDOWN ANCHORS. BRING LOOSE END AROUND THE BOTTOM STRAPPING BOARD ON END GATE ASSEMBLY H AND SEAL WITH TWO SEALS PIECES MARKED ⑳. SECURE IN PLACE BY DRIVING 10d NAILS INTO THE STRAPPING BOARD ON EACH SIDE OF THE STRAP AND BENDING OVER STRAP. STAPLES MAY BE USED IF AVAILABLE. SEE GENERAL NOTE "L" ON PAGE 2 AND SPECIAL NOTE B ON THIS PAGE.
- ⑯ LOAD RETAINING STRAP, 2" X .044" OR .050" BY LENGTH-TO-SUIT STEEL STRAPPING (2 RECD). INSTALL EACH STRAP IN TWO PIECES WITH ONE END OF EACH PIECE ATTACHED TO A FLATRACK TIEDOWN ANCHOR AT LOCATIONS SHOWN. INSTALL THE SHORTEST STRAPS FIRST THEN THE LONGER STRAPS OVER TOP OF SHORT STRAPS AND TO DIFFERENT TIEDOWN ANCHORS. BRING LOOSE ENDS AT AN ANGLE UP AND AROUND THE TOP STRAPPING BOARD ON END GATE ASSEMBLY H. POSITION STRAPS ON THE BEVELED SURFACE AND SEAL WITH TWO SEALS MARKED ⑳. SECURE IN PLACE BY DRIVING 10d NAILS INTO THE STRAPPING BOARD ON EACH SIDE OF THE STRAP AND BENDING OVER STRAP. STAPLES MAY BE USED IF AVAILABLE. SEE GENERAL NOTE "L" ON PAGE 2 AND SPECIAL NOTE B ON THIS PAGE.
- ⑰ HOLD-DOWN STRAP, 2" X .044" OR .050" BY LENGTH-TO-SUIT STEEL STRAPPING (8 RECD). INSTALL EACH STRAP IN TWO PIECES WITH ONE END OF EACH PIECE ATTACHED TO A STAKE POCKET OR TIEDOWN ANCHOR ON SIDE OF FLATRACK. BRING LOOSE ENDS UP OVER TOP OF STRAPPING BOARD AND SEAL WITH TWO SEALS PIECES MARKED ⑳. SECURE IN PLACE BY DRIVING 10d NAILS INTO THE STRAPPING BOARD ON EACH SIDE OF THE STRAP AND BENDING OVER STRAP. STAPLES MAY BE USED IF AVAILABLE. SEE GENERAL NOTE "L" ON PAGE 2 AND THE HOLD-DOWN STRAP THREADING DETAILS ON PAGES 56 AND 57.
- ⑱ EDGE PROTECTOR, STEEL, FOR 2" STEEL STRAPPING (2 RECD). POSITION UNDER STRAP MARKED ⑮ AT SHARP CORNER OF A-FRAME. IF EDGE PROTECTORS ARE NOT AVAILABLE USE A SHORT PIECE OF 2" STEEL STRAPPING.
- ⑲ PAD, 2" X .044" OR .050" X 24" LENGTH OF STEEL STRAPPING (12 RECD). POSITION THROUGH STAKE POCKET UNDER STRAPS MARKED ⑰. SECURE WITH ONE SEAL MARKED ⑳. SEE THE HOLD-DOWN STRAP THREADING DETAIL ON PAGE 57.
- ⑳ SEAL FOR 1-1/4" STEEL STRAPPING (20 RECD). ONE SEAL FOR EACH STRAP MARKED ⑮, ⑯, ⑰. DOUBLE CRIMP EACH SEAL. SEE GENERAL NOTE "M" ON PAGE 2.
- ㉑ SEAL FOR 2" STEEL STRAPPING (76 RECD). SIX SEALS FOR EACH STRAP THREADED THRU STAKE POCKETS AND FOUR SEALS FOR EACH STRAP ATTACHED TO TIEDOWN ANCHORS. DOUBLE CRIMP EACH SEAL. SEE GENERAL NOTE "L" ON PAGE 2.

| BILL OF MATERIAL | | |
|----------------------------------------|-------------|------------|
| LUMBER | LINEAR FEET | BOARD FEET |
| 1" X 6" | 5 | 3 |
| 2" X 2" | 8 | 3 |
| 2" X 4" | 169 | 113 |
| 2" X 6" | 322 | 322 |
| NAILS | NO. RECD | POUNDS |
| 6d (2") | 11 | 1/4 |
| 10d (3") | 511 | 8 |
| STEEL STRAPPING, 1-1/4" | 344' RECD | 50 LBS |
| STEEL STRAPPING, 2" | 460' RECD | 154 LBS |
| SEAL FOR 1-1/4" STRAPPING | 20 RECD | 17 LBS |
| SEAL FOR 2" STRAPPING | 76 RECD | 12 LBS |
| EDGE PROTECTOR FOR 2" STRAPPING-2 RECD | | NIL |

LOAD AS SHOWN

| ITEM | QUANTITY | WEIGHT (APPROX) |
|---------------------|----------|-------------------|
| 155 MM SLP PLTS | 36 | 31,464 LBS |
| DUNNAGE | | 1,108 LBS |
| TOTAL WEIGHT | | 32,572 LBS |