



**NAVAL  
POSTGRADUATE  
SCHOOL**

**MONTEREY, CALIFORNIA**

---

**MBA PROFESSIONAL REPORT**

---

**An Analysis of the Benefits and Savings of the Center of Excellence  
within the Fleet Readiness Centers**

---

**By: Philip Deboe,  
John Goolsby  
December 2007**

**Advisors: Uday Apte  
Keebom Kang  
Susan Heath**

*Approved for public release; distribution is unlimited.*

THIS PAGE INTENTIONALLY LEFT BLANK

<b>REPORT DOCUMENTATION PAGE</b>			<i>Form Approved OMB No. 0704-0188</i>
Public reporting burden for this collection of information is estimated to average 1 hour per response, including the time for reviewing instruction, searching existing data sources, gathering and maintaining the data needed, and completing and reviewing the collection of information. Send comments regarding this burden estimate or any other aspect of this collection of information, including suggestions for reducing this burden, to Washington headquarters Services, Directorate for Information Operations and Reports, 1215 Jefferson Davis Highway, Suite 1204, Arlington, VA 22202-4302, and to the Office of Management and Budget, Paperwork Reduction Project (0704-0188) Washington DC 20503.			
<b>1. AGENCY USE ONLY (Leave blank)</b>	<b>2. REPORT DATE</b> December 2007	<b>3. REPORT TYPE AND DATES COVERED</b> MBA Project	
<b>4. TITLE AND SUBTITLE:</b> An Analysis of the Benefits and Savings of the Center of Excellence Within the Fleet Readiness Centers		<b>5. FUNDING NUMBERS</b>	
<b>6. AUTHOR(S)</b> LCDR Phillip L Deboe and LT John Goolsby		<b>8. PERFORMING ORGANIZATION REPORT NUMBER</b>	
<b>7. PERFORMING ORGANIZATION NAME(S) AND ADDRESS(ES)</b> Naval Postgraduate School Monterey, CA 93943-5000		<b>10. SPONSORING/MONITORING AGENCY REPORT NUMBER</b>	
<b>9. SPONSORING /MONITORING AGENCY NAME(S) AND ADDRESS(ES)</b> N/A		<b>11. SUPPLEMENTARY NOTES</b> The views expressed in this thesis are those of the author and do not reflect the official policy or position of the Department of Defense or the U.S. Government.	
<b>12a. DISTRIBUTION / AVAILABILITY STATEMENT</b> Approved for public release; distribution is unlimited		<b>12b. DISTRIBUTION CODE</b>	
<b>13. ABSTRACT (maximum 200 words)</b> <p>Recognizing the need to reduce cost, Naval Air Systems Command (NAVAIR) reorganized the Intermediate and Depot level maintenance structures to form the combined Fleet Readiness Center. By combining Intermediate and Depot facilities, NAVAIR can reduce Aviation Depot Level Repairable (AVDLR) costs by interdicting Beyond Capable Maintenance AVDLR's. NAVAIR further consolidated the Naval Aviation Enterprise by creating Centers of Excellence (COE) at designated FRC's to limit the amount of repair sites for particular Weapon Repairable Assemblies.</p> <p>The purpose of this MBA Project is to demonstrate that the COE decreases turn-around-time and drastically reduces AVDLR costs by interdicting BCM AVDLR's. This project provides a comprehensive overview of efficiencies and cost savings gained by FRC West's APG-65/73 radar system COE. This project utilizes Arena Software creating a model that better quantifies the benefits of the COE maintenance structure. In addition to demonstrating efficiencies, this project highlights potential detractors that could cause the COE to fall short of its intended goals of better efficiency and cost savings realization. This project was sponsored by FRC West, located in Lemoore, CA. The results identified by this project focus on FRC West, however, they can be generalized and be made applicable throughout the Naval Aviation Enterprise.</p>			
<b>14. SUBJECT TERMS</b> Center of Excellence, Airspeed, Naval Air Enterprise, APG 65/73, FRC West, Lemoore, Simulation Modeling, Beyond Capable Maintenance		<b>15. NUMBER OF PAGES</b> 59	
		<b>16. PRICE CODE</b>	
<b>17. SECURITY CLASSIFICATION OF REPORT</b> Unclassified	<b>18. SECURITY CLASSIFICATION OF THIS PAGE</b> Unclassified	<b>19. SECURITY CLASSIFICATION OF ABSTRACT</b> Unclassified	<b>20. LIMITATION OF ABSTRACT</b> UU

THIS PAGE INTENTIONALLY LEFT BLANK

**Approved for public release; distribution is unlimited**

**AN ANALYSIS OF THE BENEFITS AND SAVINGS OF THE CENTER OF  
EXCELLENCE WITHIN THE FLEET READINESS CENTERS**

Phillip L. Deboe  
Lieutenant Commander, Supply Corps, United States Navy  
B.S. Finance, Norfolk State University, 1997

John W. Goolsby  
Lieutenant, United States Navy  
B.S. Professional Aeronautics, Embry-Riddle Aeronautical University, 2005

Submitted in partial fulfillment of the  
requirements for the degree of

**MASTER OF BUSINESS ADMINISTRATION**

from the

**NAVAL POSTGRADUATE SCHOOL  
December 2007**

Authors:

\_\_\_\_\_  
Phillip L. Deboe

\_\_\_\_\_  
John W. Goolsby

Approved by:

\_\_\_\_\_  
Keebom Kang, Lead Advisor

\_\_\_\_\_  
Uday Apte, Support Advisor

\_\_\_\_\_  
Susan Heath, Support Advisor

\_\_\_\_\_  
Robert N. Beck, Dean  
Graduate School of Business and Public Policy

THIS PAGE INTENTIONALLY LEFT BLANK

# **AN ANALYSIS OF THE BENEFITS AND SAVINGS OF THE CENTER OF EXCELLENCE WITHIN THE FLEET READINESS CENTERS**

## **ABSTRACT**

Recognizing the need to reduce cost, Naval Air Systems Command (NAVAIR) reorganized the Intermediate and Depot level maintenance structures to form the combined Fleet Readiness Center. By combining Intermediate and Depot facilities, NAVAIR can reduce Aviation Depot Level Repairable (AVDLR) costs by interdicting Beyond Capable Maintenance AVDLR's. NAVAIR further consolidated the Naval Aviation Enterprise by creating Centers of Excellence (COE) at designated FRC's to limit the amount of repair sites for particular Weapon Repairable Assemblies.

The purpose of this MBA Project is to demonstrate that the COE decreases turn-around-time and drastically reduces AVDLR costs by interdicting BCM AVDLR's. This project provides a comprehensive overview of efficiencies and cost savings gained by FRC West's APG-65/73 radar system COE. This project utilizes Arena Software creating a model that better quantifies the benefits of the COE maintenance structure. In addition to demonstrating efficiencies, this project highlights potential detractors that could cause the COE to fall short of its intended goals of better efficiency and cost savings realization. This project was sponsored by FRC West, located in Lemoore, CA. The results identified by this project focus on FRC West, however, they can be generalized and be made applicable throughout the Naval Aviation Enterprise.

THIS PAGE INTENTIONALLY LEFT BLANK

# TABLE OF CONTENTS

<b>I.</b>	<b>INTRODUCTION.....</b>	<b>1</b>
<b>A.</b>	<b>BACKGROUND .....</b>	<b>1</b>
<b>B.</b>	<b>AREA OF RESEARCH AND METHODOLOGY.....</b>	<b>3</b>
<b>C.</b>	<b>RESEARCH QUESTIONS.....</b>	<b>4</b>
<b>D.</b>	<b>STRUCTURE OF THE THESIS .....</b>	<b>4</b>
<b>II.</b>	<b>THE APG-65/73 RADAR REPAIR PROCESS.....</b>	<b>5</b>
<b>A.</b>	<b>BACKGROUND .....</b>	<b>5</b>
<b>B.</b>	<b>LEGACY REPAIR PROCESS (BEFORE FRC RESTRUCTURING) .....</b>	<b>6</b>
<b>C.</b>	<b>CENTER OF EXCELLENCE REPAIR PROCESS.....</b>	<b>7</b>
<b>D.</b>	<b>CHAPTER CONCLUSION.....</b>	<b>7</b>
<b>III.</b>	<b>SIMULATION MODELING AND ASSUMPTIONS .....</b>	<b>9</b>
<b>A.</b>	<b>ASSUMPTIONS.....</b>	<b>9</b>
<b>B.</b>	<b>DATA PROCESSING .....</b>	<b>10</b>
<b>C.</b>	<b>LEGACY MODEL .....</b>	<b>12</b>
<b>D.</b>	<b>CENTER OF EXCELLENCE MODELS .....</b>	<b>17</b>
<b>1.</b>	<b>Current State Model (FRC implemented) and Initial COE Scenario.....</b>	<b>17</b>
<b>2.</b>	<b>Future State FRC Scenarios .....</b>	<b>20</b>
<b>IV.</b>	<b>ANALYSIS AND RESULTS .....</b>	<b>23</b>
<b>A.</b>	<b>NUMBER OF ASSETS OUT.....</b>	<b>23</b>
<b>B.</b>	<b>TOTAL TIME IN SYSTEM.....</b>	<b>24</b>
<b>C.</b>	<b>TIME IN QUEUE .....</b>	<b>26</b>
<b>D.</b>	<b>SCHEDULE RESOURCE UTILIZATION .....</b>	<b>27</b>
<b>E.</b>	<b>UTILIZATION RATES .....</b>	<b>27</b>
<b>F.</b>	<b>CHAPTER CONCLUSION.....</b>	<b>29</b>
<b>V.</b>	<b>CONCLUSIONS, RECOMMENDATIONS, AND AREAS FOR FURTHER RESEARCH .....</b>	<b>31</b>
<b>A.</b>	<b>CONCLUSIONS AND RECOMMENDATIONS.....</b>	<b>31</b>
<b>B.</b>	<b>AREAS FOR FURTHER RESEARCH.....</b>	<b>33</b>
	<b>APPENDIX.....</b>	<b>35</b>
	<b>LIST OF REFERENCES.....</b>	<b>39</b>
	<b>INITIAL DISTRIBUTION LIST .....</b>	<b>41</b>

THIS PAGE INTENTIONALLY LEFT BLANK

## LIST OF FIGURES

Figure 1.	Example of Arena Logic for Simulation Arrival of NRFI parts at FRC West, NAS Lemoore. ....	13
Figure 2.	Example of Arena Logic for Simulation Times in-work decrement loop and AWP delay module. ....	14
Figure 3.	Example of Arena Logic for Simulation Beyond Capable Maintenance Delay Module.....	15
Figure 4.	Example of Arena Logic for Simulation Legacy System – COE System, BCM vs. 63X. ....	18
Figure 5.	Legacy Simulation Model.....	35
Figure 6.	Fleet Readiness Center Simulation Model.....	36

THIS PAGE INTENTIONALLY LEFT BLANK

## LIST OF TABLES

Table 1.	Maintenance Status Codes (CNAF).....	10
Table 2.	Distribution Analysis .....	11
Table 3.	Distributions fitted utilizing Arena Input Analyzer .....	12
Table 4.	Summary of Simulation .....	24
Table 5.	Labor Calculations .....	29
Table 6.	Inventory Reduction.....	32

THIS PAGE INTENTIONALLY LEFT BLANK

## ACKNOWLEDGMENTS

The authors would like to thank the following people for their help in the completion of this project:

We would like to thank CWO4(ret.) David Heinauer, COMFRC AIRSpeed Director, for the idea, information, and guidance that made this project possible.

We would like to thank Commander John Kemna, Commanding Officer, Fleet Readiness Center West, along with his hardworking sailors and staff, and Ms. Alice Kilgore, Aviation Depot Level Repairables Officer, Aviation Supply Division, Lemoore CA. Their support and assistance in our data collection was instrumental in the completion of this project.

We would also like to thank our advisors, Professors Keebom Kang, Susan Heath and Uday Apte for their guidance and help.

Phillip Deboe's Acknowledgment:

First and foremost, I would like to thank God for allowing me the opportunity to pursue this advanced degree, and my wife Juanita for her undying love and support throughout my entire educational process and naval career. Without her, I could not have done this. Juanita, I love and thank you.

THIS PAGE INTENTIONALLY LEFT BLANK

## LIST OF ACRONYMS AND ABBREVIATIONS

AIMD	Aviation Intermediate Maintenance Department
AMSU	Aviation Material Screening Unit
ASD	Aviation Supply Department
AVDLR	Aviation Depot Level Repairable
AWM	Awaiting Maintenance
AWP	Awaiting Parts
BCM	Beyond Capable Maintenance
CASS	Consolidated Automated Support System
COE	Center of Excellence
CSFWP	Commander, Strike Fighter Wing, U.S. Pacific Fleet
DON	Department of the Navy
DOD	Department of Defense
FRC	Fleet Readiness Center
FRC WEST	Fleet Readiness Center West, NAS Lemoore, CA
FST	Fleet Support Team
MCN	Maintenance Control Number
MDT	Mean Down Town
MTBF	Mean Time Between Failure
NAE	Naval Aviation Enterprise
NALCOMIS	Naval Aviation Logistics Command Management Information System
NAVAIR	Commander, Naval Air Systems Command
NAVICP	Naval Inventory Control Point
NRFI	Non-Ready For Issue
PC	Production Control
RFI	Ready For Issue
SEAOPDET	Sea Operational Detachment
SRA	Sub-Repairable Assembly
W/R	Work Request
WRA	Weapons Repairable Assembly

THIS PAGE INTENTIONALLY LEFT BLANK

## I. INTRODUCTION

### A. BACKGROUND

We are well into the twenty-first century, and the Department of the Navy still faces what well may be the single most detrimental degrader of our service, fiscal irresponsibility. Now, more than ever, the DON is focusing its efforts on curbing what has become a financial “death spiral.” The new enterprise effort the Navy has initiated is one of many steps to help stop irresponsible spending and promote a more businesslike approach to our service. Naval aviation has taken the lead role in reducing its financial footprint while simultaneously increasing readiness.

In a 2006 interview with *Approach* magazine, VADM Massenburg, Commander of Naval Air Systems Command, was quoted as saying,

We had it wrong for so many years. What happens at the end of every fiscal year? We think that we have to burn up that gas, we’ve got to use up those hours, because if we don’t get to zero we’ll get fired. Success was to fly as much as we could.

Throughout Naval Aviation, this consumption attitude led to the creation of Naval Aviation Enterprise (NAE), which is the vehicle for fundamental change in Naval Aviation. The mantra throughout Naval Aviation was “readiness at any cost.” Now, the mantra throughout Naval Aviation is “Cost-wise readiness.” (Steber 2006)

The NAE is a warfighting partnership in which interdependent issues affecting multiple commands are resolved on an enterprise-wide basis. The NAE enables communication across all elements of the enterprise, fosters organizational alignment, encourages inter-agency and inter-service integration, stimulates a culture of productivity, and facilitates change when change is needed to advance and improve business practices. Working together can help optimize the use of existing resources, better manage the costs associated with generating readiness, and harness change as a positive force within our Navy and Marine Corps. (CNAF)

NAE uses many tools to achieve cost-wise readiness, such as Naval Aviation Readiness Integrated Improvement Program, AIRSpeed, and Lean/Six Sigma. For the purpose of this project, we will focus on AIRSpeed, Lean/Six Sigma and Theory of Constraints to model the repair process at the new Center of Excellence (COE) for the APG-65/73 radar.

With the current budget shortfalls that all branches of Department of Defense are experiencing, several initiatives have been implemented to increase savings to fund our future fleet. One of the most innovative changes within the NAE is the combination of the Intermediate and Depot levels of maintenance under one command creating Fleet Readiness Centers (FRC). Initiated by the 2005 BRAC report, Naval Air Systems Command reorganized the Intermediate and Depot level maintenance structures to form the combined FRC. Naval aviation is composed of organizational, intermediate, and depot levels of maintenance. Organization maintenance is limited to squadron-level scheduled and unscheduled maintenance. When the squadron removes a defective part from an aircraft for repair, it is sent to the Aircraft Intermediate Maintenance Department (AIMD). AIMD is composed of sailors performing intermediate maintenance. If the extent of the damage is beyond the level of AIMD, they will send it to the third and final level of maintenance, the depot, by initiating a Beyond Capable Maintenance (BCM) action. The depot is composed of civilian artisans performing overhaul, rework, and the most complex repairs. By combining intermediate and depot facilities, NAVAIR will be able to significantly reduce Aviation Depot Level Repairable (AVDLR) costs by interdicting Beyond Capable Maintenance AVDLRs. When a part is repaired at the intermediate level, no costs are initiated with the exception of consumables required to facilitate the repair. When an AVDLR is BCM'd to the depot, a net AVDLR charge is incurred by the command that ordered the replacement AVDLR. By interdicting BCM's the navy is able to forego these AVDLR charges. By combining the intermediate and depot levels of maintenance, the part is able to remain "in-house". From an overall supply chain point of view, changing to an FRC configuration moves labor from the depot to the intermediate-level facility and should allow for a substantial reduction in infrastructure.

In attempts to become more lean, NAVAIR further consolidated the Naval Aviation Enterprise by creating Centers of Excellence (COE) at designated FRC's to limit the amount of repair sites and required infrastructure in support of particular Weapon Repairable Assemblies (Hardee 2007). The COE is designed to limit the number of repair sites by achieving the full effect and optimization of combining sailors and depot artisans in one repair process. The result of the COE change will be to increase the number of parts requiring repair arriving to each COE.

## **B. AREA OF RESEARCH AND METHODOLOGY**

Our project examines the APG-65/73 radar weapons system COE maintenance structure at FRC West, which is located at NAS Lemoore, CA. Our first goal is to determine the gains and losses with respect to the turn-around-time of parts through the FRC by analyzing the repair processes for the APG-65/73 radar weapon system before and after reorganizing as FRC and COE implementation. Our second goal illustrates how turn-around-time will be affected when the COE reaches steady-state with increased throughput and verify if it will be sustainable with the current allocation of resources. Our last goal determines the proper level of resources, i.e., test benches, personnel and working hours. This project will use simulation models to meet our objectives and demonstrate the positive effects of the COE maintenance structure and full AIRSpeed implementation. NAVAIR AIRSpeed is the acquisition community's vehicle used to reduce the cost of business, improve productivity, and improve customer satisfaction. AIRSpeed tools empower employees to take control of work processes. Employees are directly involved in identifying/eliminating waste, reducing cycle time, reducing costs and improving quality of work—all with complete management support (NAVAIR). When designing the APG-65/73 COE, AIRSpeed tools such as theory of constraints, Lean and Six Sigma were incorporated to ensure efficient maintenance practices and to eliminate as much waste as possible.

The simulation models are based on information obtained from Fleet Readiness Center West. The focus will remain on the APG-65/73 COE at FRC West to maintain scope and clarity of data. FRC West and the APG-65/73 radar is the prototype for future

product COE's (Daniels 2007). Other FRC's and COE's will not be addressed in this project. Using data collected from FRC West, we will conduct before and after scenarios illustrating the advantages and some cost savings associated with the FRC and COE maintenance structures. These simulations are created using Arena 10.0 simulation software package. Upon completion of the simulations, an analysis of the results will determine the effects of the FRC and COE implementations and illustrate any detractors associated with the FRC and COE maintenance structures.

### **C. RESEARCH QUESTIONS**

To achieve our goals, we will answer the following questions:

1. How has the Turn-around-Time (TAT) changed between the legacy process and the FRC process with COE implementation?
2. How will the system capacity be affected when FRC reaches steady-state with increased throughput and is steady-state sustainable with the current resources?
3. How is utilization affected, i.e., personnel, test benches, and working hours when FRC reaches steady-state with increased throughput and is steady-state sustainable with the current resources?

### **D. STRUCTURE OF THE THESIS**

The project is structured into five chapters. Chapter I provides a broad overview of the thesis subject, states the objective of the project, identifies research questions, describes the scope of our research effort and presents our research methodology. Chapter II discusses the background of the legacy and COE repair processes for the APG-65/73 radar weapon system. Chapter III presents assumptions and illustrates the development of the legacy model simulation utilizing ARENA software, and elaborates on the development of five independent scenarios for the COE simulation models. Chapter IV analyzes the results and comparisons of all six simulations. Chapter V provides a summary of our project research, conclusions, and recommendations for future study.

## **II. THE APG-65/73 RADAR REPAIR PROCESS**

### **A. BACKGROUND**

The 2005 Base Realignment Commission directed realigning and merging depot and intermediate maintenance facilities under one command, designated FRC's. This realignment created six FRC's and thirteen affiliated FRC sites at satellite locations. The purpose of the realignment/reorganization was to support the DoD and Navy transformation goals by reducing the number of maintenance levels and streamlining the way maintenance is accomplished with associated significant cost reductions. Additionally, realignment supports the NAE goal of transforming to fewer maintenance levels, i.e., from three to two levels. The realignment also supports the NAE's strategy of positioning maintenance activities close to fleet concentrations. Doing so will result in enhanced effectiveness and efficiency, greater agility, while allowing naval aviation to achieve the desired readiness at lower cost. The estimated net present value of savings to the Department of the Navy over twenty years is \$4,724 M (USDoD 2005).

Upon establishment of FRC West, the APG-65/73 COE was created, composed of work centers 63E and 63X. Prior to restructuring work center 63D, now 63E, was the traditional AIMD work center. The newly created depot work center, 63X, is where 63D would traditionally send Beyond Capable Maintenance (BCM) parts, meaning, a part would be sent off station to a depot repair facility that can repair the part in exchange for an identical working part. This is the fundamental change with the creation of FRC's. Now the BCM maintenance actions are repaired in-house. For accounting purposes, the work centers are separate to keep record of sailor and civilian labor hours. Along with the interdiction of BCM's, another benefit of the FRC and COE concepts is pushing maintenance closer to the flight line. By moving the depots into the intermediate level maintenance activities, the repair process was streamlined and many non-value added steps were removed. Under the legacy repair process, the BCM process created a lengthy and unnecessary step process, with no customer value added. The FRC reorganization removed the non-value added steps from the process.

## **B. LEGACY REPAIR PROCESS (BEFORE FRC RESTRUCTURING)**

The first step in the repair process is that the squadron discovers a Non-Ready For Issue (NRFI) part in their aircraft. Once the squadron removes the NRFI part and prepares it for turn-in to their local aviation supply department, they can order a Ready For Issue (RFI) part. When supply department receives the requisition for the RFI part, an RFI asset will be delivered, if available, and pick up the NRFI asset. At this point, the NRFI part enters the repair cycle.

In the legacy repair process, the NRFI part is delivered by supply to the Aviation Material Screening Unit (AMSU). Upon receiving a NRFI part, AMSU screens the part and verifies if the FRC has the capability to repair the part. If it is determined that the FRC has repair capability, Production Control assigns a work priority and AMSU transfers the part to the work center.

Parts associated with the APG-65/73 radar system are assigned to the 63D work center. Upon receipt the part, 63D does an initial operational test and check to determine the extent of damage. Occasionally during the initial operational test and check, a part is determined RFI, but in most cases the technicians verify the NRFI status and determine any necessary parts to order to facilitate repair. In some instances, it is determined that the extent of the damage is beyond the scope of their capabilities, and the part requires a BCM action.

The parts of the APG-65/73 radar system consist of 33 Weapon Repairable Assemblies (WRA) and 169 Sub Repairable Assemblies (SRA) (Schilling 2007), which is a sub-component of the WRA. If after the initial test and check the technicians identify have a bad SRA, the SRA is inducted and treated like a traditional NRFI AVDLR turned in by a squadron, and is inducted into AMSU and the repair process starts over. If it is determined that the part can not be repaired by the AIMD, it will be BCM'd to the depot facility. Once 63D makes all the required repairs and determines the asset to be RFI, all paperwork is completed and attached, then turned over to supply department for restocking and future issue, or sent directly to the squadron if the part was back-ordered.

### **C. CENTER OF EXCELLENCE REPAIR PROCESS**

The repair process for the COE is very similar to the legacy process. The major difference under the COE process is that the depot artisans are combined with the intermediate level sailors; therefore, few parts are ever BCM'd. On rare occasions, a part may still be BCM'd to the original equipment manufacture or major depot. When an NRFI part arrives, it goes through AMSU, PC, and 63E the same manner as the legacy process (where 63E is just the new designation for the 63D sailors). The APG-65/73 COE is arranged so that the depot artisans only work on the most complex repairs, but are always available to provide "over the shoulder" assistance to the intermediate-level sailors. Once 63E receives the NRFI part, they perform their initial operational test and check to determine if the part is RFI or can be RFI'd with minor adjustments, or if it will go to awaiting parts (AWP), or BCM. If a part is deemed to be beyond the scope of 63E, it will be transferred to 63X in lieu of the legacy BCM process. Once 63X repairs the asset, it goes back to 63E for final operational test and check. Once the part is deemed RFI, the final steps are the same as in the legacy repair process (Shilling 2007).

### **D. CHAPTER CONCLUSION**

By combining the depot and intermediate levels, BCM's are able to be interdicted, significantly reducing AVDLR costs. Reducing AVDLR cost is one of the tangible benefits of the FRC and COE reorganization. There are other intangible benefits. The intermediate level side of the FRC still provides sailors as Sea Operational Detachments (SEAOPDET) to deployed aircraft carriers augmenting the ship's crew with aviation maintenance support. The advantage of these sailors working side-by-side depot-level artisans is evident. Sailors are gaining invaluable experience from depot-level technicians and OEM contracted technical representatives who have a wealth of knowledge on these systems. The SEAOPDET sailors are taking this knowledge to the aircraft carriers while on deployment. The COE provides a sense of ownership in the sailors that may not have existed before. Prior to the COE, a sailor had an option to BCM a part, but because artisans and sailors are working side-by-side, it will be extremely rare that parts will be BCM'd outside the COE. The COE for the APG-65/73 radar system is still in its relative

infancy stage. Our intent is to highlight the benefits and detractors of the FRC and COE changes through simulation. We believe the benefits are there, and with continued focus, the desired results will be achieved.

### **III. SIMULATION MODELING AND ASSUMPTIONS**

#### **A. ASSUMPTIONS**

Due to the complexity of the maintenance processes associated with a maintenance activity the size of FRC West, it would be virtually impossible to model the repair process with absolute precision using software-based simulation. For the purposes of this project, it is unnecessary to model that level of detail and complexity. In constructing the models, assumptions are inevitable and necessary. Six models were constructed to illustrate multiple scenarios. The first scenario represents the legacy repair process prior to FRC implementation. The subsequent models represent multiple scenarios of the FRC process with variations in the level of the COE implementation. Independent scenarios were explored to determine the effects of increase in arrivals, different resources, and working hours. The repair process for the APG-65/73 radar system is too complicated to model with absolute accuracy, so certain assumptions were made:

1. In our simulation models, we wanted to illustrate the effects of the overall repair process within the APG-65/73 COE. It was not necessary or relevant to model the repair details for each different type of part. Therefore, we grouped all 202 types of WRAs and SRAs together into one part type.
2. Working hours and number of personnel recorded in NALCOMIS is accurate.
3. The FRC maintenance structure results in zero BCM's. In actuality the FRC does still BCM a small amount of parts, but to get a more accurate assessment of the FRC's turn-around-time, we limited the number of BCM's to zero.
4. Work center 63E's repair times can be accurately modeled utilizing 63D's repair data. This was done to maintain a controlled comparison between the scenarios, such that the only thing that changed was switching between BCM'd parts external to the COE and all parts being repaired in-house with the addition of work center 63X.

5. The RF and Hi-PWR Consolidated Automated Support System (CASS) benches run the same parts. The only resources that are seized within the model are five high-power and three RF CASS benches. In the future state COE models, there are four CASS benches. Due to grouping all parts into one part type and not assigning repair attributes to each individual part, we grouped the CASS benches as one resource. In reality, certain WRA's have to be conducted on a specific bench. Example: The transmitter for the APG-65/73 radar system can only be run on the high-power CASS bench. In this model, we grouped all eight benches into one resource set and will let the model determine which bench is utilized.

**B. DATA PROCESSING**

To ensure accuracy, we utilized data obtained directly from NALCOMIS whenever possible. NALCOMIS data was exported utilizing Microsoft Excel. We took all the parts that arrived to FRC West and were inducted to work center 63D for the period of April–June 2006, directly from NALCOMIS. The April-June 2006 time period represented the last quarter of data prior to the FRC implementation.

The APG-65/73 radar system is composed of multiple Weapon Repairable Assemblies and Sub Repairable Assemblies. Each part has different repair times, test bench requirements, RFI rates, and different bit/piece parts required to facilitate the repair process. Data was grouped by Maintenance Action Control Number (MCN) and maintenance action status using excel. (Table 1)<sup>1</sup>

A1	Pre-Induction Screening	M8	AWM Awaiting Other Shops
IW	In Work	WP	AWP In Shop
M3	AWM Backlog	WS	AWP Work Stoppage
M6	AWM Awaiting AIMD		
Table 1. Maintenance Status Codes (CNAF)			

<sup>1</sup> Table 1 only defines maintenance status codes represented in Table 2. A complete list of maintenance status codes can be found in CNAFINST 4790.2.

Each time a job status changes, the technician updates the work order in NALCOMIS with the applicable maintenance status code, creating a maintenance action date/time stamp. To limit the complexity and meet the functionality of the model, we grouped all parts inducted for one quarter, and fitted their variations in inter-arrival times, processing times, and routing decision percentages into distributions. Once the NALCOMIS data was grouped, we were able to use the date/time stamps to compute the elapsed times between each change in maintenance action status (Table 2).

mcn	Maint_act_sts	maint_act_dttm	Total hrs
PF58EXB	A1	06:48:00	0.22
PF58EXB	M3	07:01:30	217.23
PF58EXB	IW	08:15:59	0.50
PF58EXB	WS	08:45:59	0.25
PF58EXB	WP	09:00:59	3.67
PF58EXB	M6	12:40:59	0.33
PF58EXB	M3	13:00:59	18.00
PF58EXB	IW	07:00:59	2.00
PE39WVR	A1	11:19:00	0.05
PE39WVR	M3	11:22:45	70.13
PE39WVR	IW	09:30:59	2.00
PE39WVR	WS	11:30:59	0.28
PE39WVR	WP	11:47:59	1.43
PE39WVR	M6	13:13:59	0.12
PE39WVR	IW	13:20:59	2.00
PE39WVR	M3	15:20:59	39.42
PE39WVR	IW	06:45:59	3.00
PE39WVR	WS	09:45:59	0.57
PE39WVR	WP	10:19:59	0.60
PE39WVR	M6	10:55:59	0.33
PE39WVR	M8	11:15:59	0.50
PE39WVR	M3	11:45:59	0.25
PE39WVR	IW	12:00:59	0.75

Table 2. Distribution Analysis

As previously stated, the arrival times, repair times, and supply times were obtained directly from NALCOMIS data. It is acknowledged that maintenance status codes are not updated exactly when the action takes place, but they are the most accurate data available.

Once the elapsed times were determined for each data set, Arena’s Input Analyzer was used to fit a distribution to each set of data. The “best fit” distribution, as determined by Input Analyzer using the squared error test, was not necessarily the distribution used. The exponential distribution was chosen because the fitted distribution’s mean always matched sample data mean so the model would correctly generate average arrivals and process times. In addition, exponential distributions have high variability, so they can be used to demonstrate a worst-case level of variability. When comparing both the mean and the sum-of-squares measure of several distributions, it was not clear which distribution best reflected the true underlying distribution. Therefore all data was fitted to an exponential distribution (Table 3).

MODEL	ARRIVAL	IW/TC	63D/E AWP	63X AWP	63D/E REPAIR	63X REPAIR	BCM Delay
LEGACY MODEL	EXPO(12.9)	EXPO (2.21)	EXPO (36.7)	COE Only	EXPO(2.82) + TRIA(0.0,0.45,2)	N/A	TRIA (48,648,2592)
COE MODEL	EXPO(12.9)	EXPO (2.21)	EXPO (36.7)	EXPO (89.5)	EXPO(2.82) + TRIA(0.0,0.45,2)	EXPO(2.96) + TRIA(0.0,0.45,2)	N/A
10% INCREASE IN PARTS	EXPO(11.7)	EXPO (2.21)	EXPO (36.7)	EXPO (89.5)	EXPO(2.82) + TRIA(0.0,0.45,2)	EXPO(2.96) + TRIA(0.0,0.45,2)	N/A
24 WORKING HOURS/9 BENCHES	EXPO(12.9)	EXPO (2.21)	EXPO (36.7)	EXPO (89.5)	EXPO(2.82) + TRIA(0.0,0.45,2)	EXPO(2.96) + TRIA(0.0,0.45,2)	N/A
25% INCREASE IN PARTS	EXPO(10.3)	EXPO (2.21)	EXPO (36.7)	EXPO (89.5)	EXPO(2.82) + TRIA(0.0,0.45,2)	EXPO(2.96) + TRIA(0.0,0.45,2)	N/A
50% INCREASE IN PARTS	EXPO(8.61)	EXPO (2.21)	EXPO (36.7)	EXPO (89.5)	EXPO(2.82) + TRIA(0.0,0.45,2)	EXPO(2.96) + TRIA(0.0,0.45,2)	N/A
Table 3. Distributions fitted utilizing Arena Input Analyzer							

### C. LEGACY MODEL

The legacy simulation model commenced with the arrival of a part (Figure 1) at time zero. Subsequent entities were generated at random intervals using the probability distribution fitted to the NALCOMIS data gathered from second quarter 2006. The data

show that, in a three-month period, 190 parts were inducted into work center 63D at AIMD Lemoore. To simulate an accurate arrival distribution, we utilize input analyzer resulting in an exponential distribution with a mean inter-arrival time of 12.9 hours. The first step in the induction process begins with the AMSU/PC process. Using input analyzer, we took the A1 processing times from NALCOMIS and fit a distribution to the data to account for the AMSU processing time. It should be noted that we only used NALCOMIS data for the APG-65/73 radar system. The AMSU processing time does not account for all the other parts inducted at FRC West. This was purposely done to only model the APG-65/73 repair process. Once the part is received by work center 63D, an initial test and check is performed. We fit all the data of the initial IW times from NALCOMIS resulting in an exponential distribution with a mean of 2.21 hours. In developing the simulation, we separated the IW times into two categories; the first time a part went IW is considered the initial test and check, and all subsequent IW times associated with the actual repair process. The IW times were calculated in this manner to quantify the parts that are RFI'd on the initial test and check or parts that may have been verified RFI with no maintenance required. Once the work center performed an initial test and check, a decision module was created to determine if the part was RFI or NRFI. The initial RFI vs. NRFI percentages were calculated from the NALCOMIS data by dividing the first past yield parts, a total of twelve, by total parts for the time period, 190, resulting in an initial RFI rate of 6.32 percent.

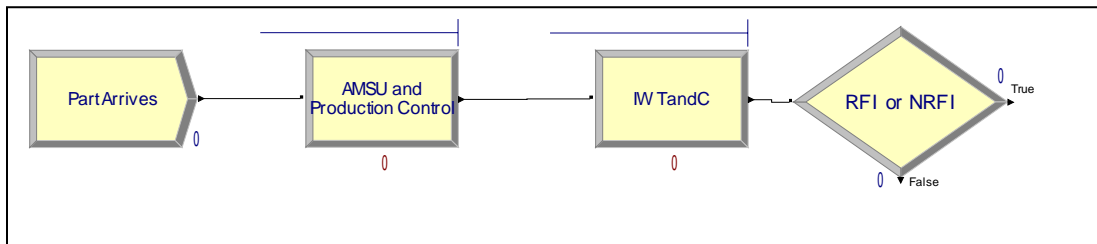

Figure 1. Example of Arena Logic for Simulation Arrival of NRFI parts at FRC West, NAS Lemoore.

Once the part is verified NRFI after the initial induction run, it enters a decision module to determine if the part goes awaiting parts (AWP) or awaiting maintenance (AWM). An AWP/AWM rate was created by determining that 31 of the 190 parts

inducted during the sample time period did not go AWP. In the decision module 16.32% of the parts determined to be NRFI went directly to AWM and did not require parts to repair. The remaining 83.68% require parts and enter the AWP delay module. To simulate the supply waiting time we fitted all the supply times from NALCOMIS to an exponential distribution with a mean of 36.7 hours and inserted them into a delay module (Figure 2). There was not a separate module to account for AWM time. AWM time is the time spent in queue for the actual repair process module. Once a part leaves the AWP delay module, it enters the 63D repair process. If workers and test benches are available, the part immediately goes into work. If a worker or CASS bench is unavailable, the part will queue until a worker and a CASS bench both become available. To account for the multiple times a part may go into work before it is actually RFI'd or BCM'd, an attribute was assigned to each part designating the number of times each part went into work. This number was also generated by a distribution fit to data obtained from NALCOMIS. This creates a decrement loop (Figure 2) causing the parts to loop through the repair process a random number of times similar to the actual number of times IW occurred. The actual repair times were established by fitting all the second and subsequent IW repair times to an exponential distribution with a mean of 2.82 hours. An additional triangular distribution of (0.0, 0.45, 2.0) hours was added to account for the bench setup times. Once the required number of repairs has occurred, the part leaves the 63D repair process and entered a decision module to determine RFI or NRFI.

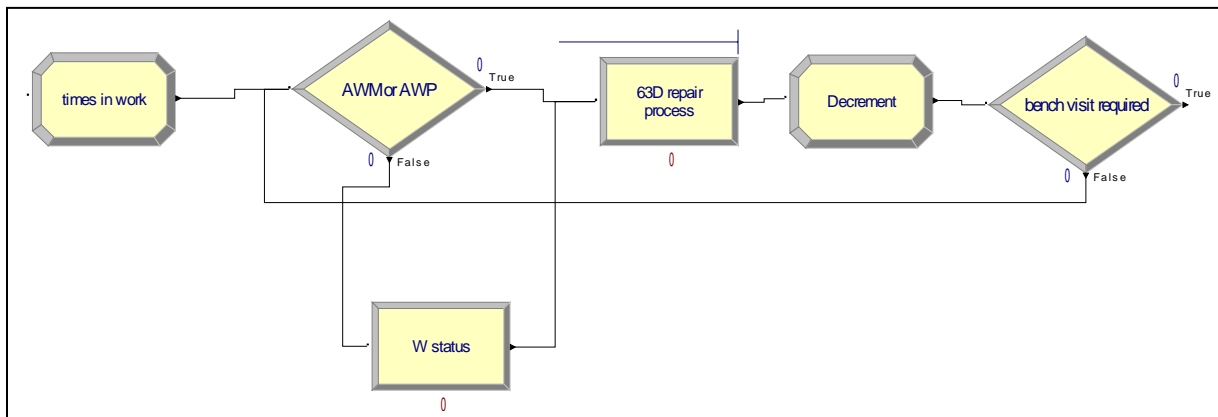

Figure 2. Example of Arena Logic for Simulation Times in-work decrement loop and AWP delay module.

Data gathered from Aviation Supply Department (ASD) Lemoore, showed out of the 190 parts inducted that AIMD Lemoore had repair capability for, 26 were processed for BCM. To establish the BCM rate we calculated  $26/178$ , or 15 percent. The denominator represents the 190 inductions minus the twelve that were RFI'd on the first past yield. To account for the BCM processing time, a BCM delay module was created (Figure 3). A triangular distribution of (2, 27, 108) days was used to model the BCM delay module based on data obtained from ASD Lemoore (Kilgore 2007). The BCM process is completed by NAVICP transferring an asset from another ASD or supply warehouse, or by the outstanding deficit being filled by the depot. The last step in the model is the part entering supply. This takes place by the asset being repaired or a BCM being filled by NAVICP.

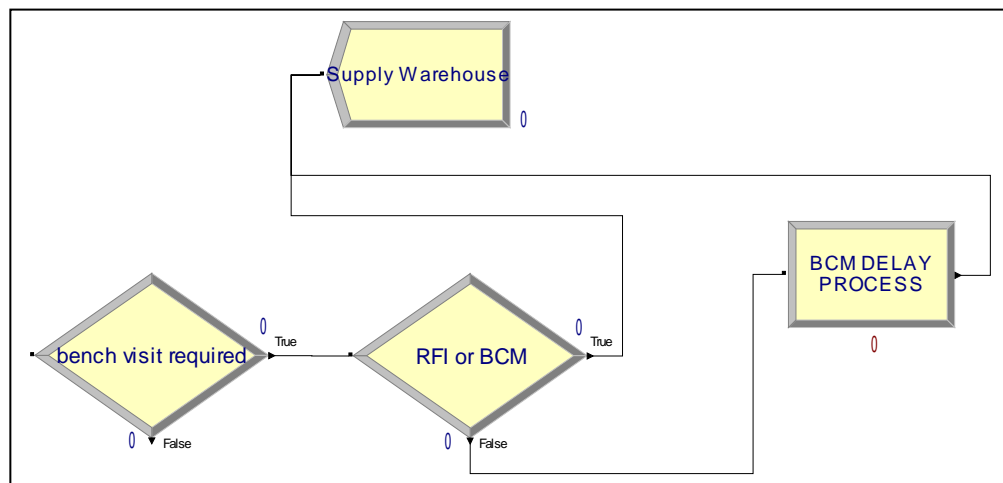

Figure 3. Example of Arena Logic for Simulation Beyond Capable Maintenance Delay Module.

In addition to establishing the distributions and rates required to ensure accuracy of the simulation, resources must be modeled. Prior to COE implantation, FRC West had eight CASS, five high-power and three RF. To account for the effects of scheduled maintenance and random failures, we created a schedule to bring one bench down for two hours daily. The 63D repair process and initial test and check modules are seize, delay,

and release: each time a part passes through the module, it seizes one test bench and one technician, it is delayed based on the repair time distribution, and then it releases the test bench and technician.

Although working hours and number of personnel are always changing, we created a labor resource pool based on historical data provided by FRC West. Work center 63D was composed of 31 technicians, working three overlapping shifts, resulting in 24-hour per day of overlapping coverage, four days per week and duty section on Friday. Working hours were established as follows:

Day shift 0630-1630; thirteen personnel assigned

Night shift 1630-0230; ten personnel assigned

Mid shift 2400-1000; eight personnel assigned

Although the work center has 31 technicians assigned, not all are involved directly with running CASS benches. We reduced the labor pool by ten personnel to account for those absent or not directly involved in maintenance. The reduction accounts for training, schools, special liberty, annual leave, and duties inherent with a military organization. A more realistic estimation of actual personnel available each shift to run a CASS bench was redistributed as follows:

Day shift 0630-1630; eight personnel assigned

Night shift 1630-0230; seven personnel assigned

Mid shift 2400-1000; six personnel assigned

The rationale for these reductions accounts for two people on leave at any one time, one Leading Petty Officer (LPO), three separate shift supervisors, one person in school/TAD, and one person on watch. It should be noted that for a work center composed of 31 personnel, if each sailor took all thirty days of entitled annual leave, it would result in 3.6 sailors on leave if spread equally over a 260-day work year. Night shift and mid shift do not have a minimum of eight personnel assigned, therefore, backlogs may be generated due to lack of personnel and at least one CASS bench sitting idle. For a part to enter the 63D repair process module, it must have one worker and one test bench available. This is minimized with overlapping shifts. Work center 63D drops below eight workers, for 11.5 hours per day between 0230-0630 and 1630-2400.

## **D. CENTER OF EXCELLENCE MODELS**

### **1. Current State Model (FRC implemented) and Initial COE Scenario**

The FRC structure combines depot and intermediate levels of maintenance. This process can take place in various forms. Depot artisans can be assigned to an AIMD work center or sailors can be assigned to a depot work center. At FRC West, three depot artisans, one contractor, and one Fleet Support Team (FST) representative are assigned to the APG-65/73 repair work center. FRC West has established two separate work centers because of the requirement to track the depot artisan's working hours and different funding pools used to pay civilian wages. 63E is the traditional AIMD work center and 63X is the depot work center. The reality is that five civilian workers and thirty-one sailors work in the confines of the same working space. Despite the proximity of the work space, the depot artisans are utilized for the more difficult repairs and the sailors are utilized for the more routine repairs. 63X is manned with one artisan per shift, with three eight-hour shifts. One contractor works during the day shift along with the day-shift depot artisan. One unique issue that results from the depot combining with the AIMD is the Fleet Support Team (FST) representative started working at FRC West. Although this does provide an "in-house" service and pushes information forward, it creates a drain on resources. The FST representative resolves problems for the entire fleet and not just FRC West. In order for the FST representative to perform his duties, he requires full utilization of one CASS test bench daily. On average, this reduces the number of test benches from eight to seven during day shift, for production purposes, on a daily basis.

The FRC simulation model was created utilizing the same data set as the legacy model. As previously mentioned, the major difference between the two processes is the interdiction of BCM maintenance actions. To maintain data integrity and to ensure an accurate comparison, we used the same inter-arrival times, resources, working hours, and AWP times. In developing the FRC model, we had to take into account the different repair rates and RFI capabilities of the two separate labor pools. These differences were quantified by using separate distributions for each work center. Additionally, a separate schedule was created to account for working hours and number of work center personnel.

The similarities between the legacy and FRC simulations end once the part goes through the 63E repair process the required number of times based on the data obtained from NALCOMIS. The FRC model simulates 63E not being able to repair the asset and sending it to the depot artisans in 63X by a decision module to determine if the part is RFI or requires the assistance of 63X. This decision module is the same as the RFI or BCM module in the legacy system. Then, instead of being processed for BCM, the part will enter the 63X repair process (Figure 4).

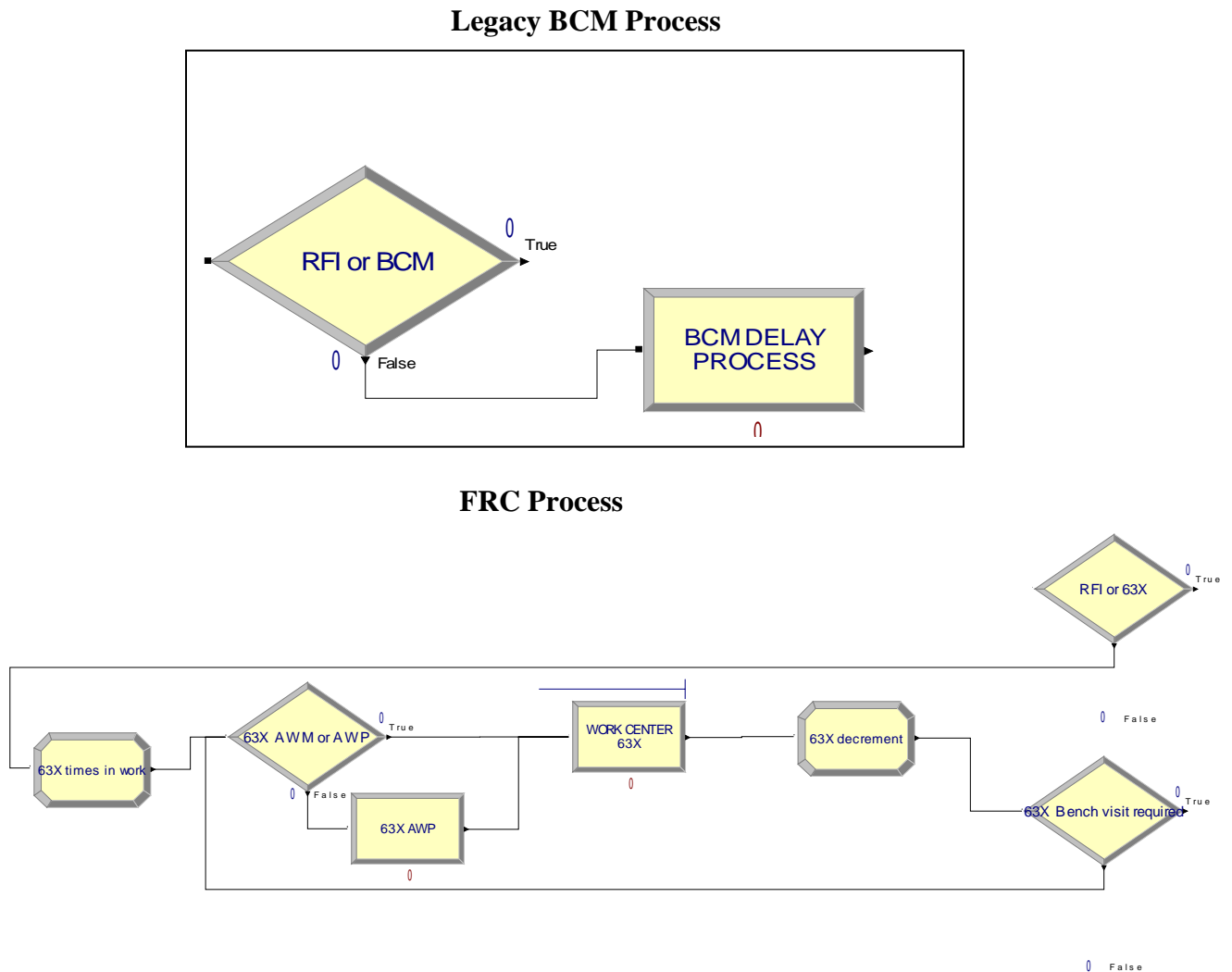

Figure 4. Example of Arena Logic for Simulation Legacy System – COE System, BCM vs. 63X.

Because 63X has different repair rates and times, data used was from April-June 2007 NALCOMIS, the most recent quarter of the COE. A distribution for the repair process was created in the same manner as 63E's distribution, resulting in an exponential distribution with a mean of 2.96. The same triangular distribution for setup times was added, as in the legacy model. Once the part exits the 63X repair process, it is returned to supply as stock replenishment.

Both, 63E and 63X pull from the same set of CASS bench resources. In addition to the CASS benches required for normal repair processes, a bench is dedicated to the Field Service Team (FST) engineer representative. To account for the loss of eight hours of bench time to support the FST, one of the eight CASS benches is assigned to the FST representative during the hours of 0800-1600. 63X has separate labor resources, as well. There are two artisans assigned to day shift, one to night shift and one to mid shift. Their working hours are incremented to account for a one-hour lunch break, resulting in the day shift going down to one worker for a two-hour period and the night and mid shift losing production during their one-hour lunch break. The FRC process works the same as the legacy process as in the part will queue unless there is one worker and one CASS bench available. Note that the FRC model now has two work centers and one FST representative pooling for the same set of resources. In the legacy system, if 63D could not repair the asset they simply processed it for BCM and left the facility. In the FRC model, the part does not leave the facility until it is RFI. Four additional scenarios of the FRC model were created to illustrate different conditions and states of the COE.

The three future-state FRC models have a 24/7 work schedule and one additional CASS test bench, but one initial FRC scenario was created to simulate a 10 percent increase in parts arriving without an increase in work days or CASS test benches. This scenario illustrates how the current state FRC responds to the initial increased demand when starting toward a full COE implementation. To illustrate this increase in demand, each inter-arrival time in the NALCOMIS data was multiplied by .91, effectively increasing the number of parts arriving by 10 percent. We used the inter-arrival times with an exponential distribution with a mean of 11.7, as opposed to the mean of 12.9 in the original current state FRC model. The results are given and analyzed in Chapter IV.

## **2. Future State FRC Scenarios**

The first future state scenario contains the same data as the current state FRC simulation, but with a 24/7 work schedule and additional CASS test bench. Over the length of our research for this project FRC West modified their working hours. During times of increased demand, FRC modified their work schedule to ensure 24-hour coverage of personnel, maximizing availability of personnel to run all CASS benches 24 hours a day. FRC West designated four twelve-hour shifts. In order to avoid having to model details of which days each shift works, the four shifts are rotated through sequentially, resulting in 24/7 coverage. In the future state FRC simulation working hours were created as follows:

Day shift one 0700-1900; nine personnel assigned

Night shift one 1900-0700; eight personnel assigned

Day shift two 0700-1900; eight personnel assigned

Night shift two 1900-0700; eight personnel assigned

As in the previous models, the number of assigned personnel was reduced to account for personnel on leave, one LPO, three separate shift supervisors, one person in school/TAD, and personnel on watch. FRC West shifts to this schedule in times of peak demand. For scope of model, we limited the number of personnel reductions to five representing one LPO, one person on leave, one person TAD/School, and one person on watch. The rationale for reducing the number of personnel available by five vice ten, as done in legacy and current state FRC models, is this 24-hour coverage design meets short run demand and is not realistically sustainable in the long run with only 33 personnel. The assumptions made were that leave was limited to only one person; all shift supervisors would be running CASS benches continuously, and minimum chow breaks. The modified schedule to account for the reduction in personnel is as follows:

Day shift one 0700-1900; seven personnel assigned

Night shift one 1900-0700; seven personnel assigned

Day shift two 0700-1900; seven personnel assigned

Night shift two 1900-0700; seven personnel assigned

In addition to increased working hours, FRC West gained an additional RF CASS bench. With the increase to nine CASS benches and the above estimated working hours, we will have at least two CASS benches sitting idle 24 hours a day due to lack of personnel. This 24/7 schedule results in two additional work days over the legacy simulation and supervisors have the flexibility to limit the amount of workers absent from the work place. The results will be presented and analyzed in Chapter IV.

Although, FRC West is the designated COE for the APG-65/73 radar system, they are not yet receiving all fleet inductions. FRC Mid-Atlantic, USMC MAWS, FRC West site Fort Worth, and AIMD's afloat are still repairing AVDLR's associated with the APG-65/73. It is assumed the AIMD's onboard aircraft carriers are going to start off-loading their category (CAT) II AVDLR's. A CAT II AVDLR is within the repair capability of the afloat AIMD to repair, however it is a more in-depth repair that is better suited for the COE. It is still yet to be determined how the USMC assets will be handled.

Our last two future state scenarios use the 24/7 work schedule, one additional CASS test bench, and 25 or 50 percent increases in arriving parts. The previous models illustrate the effects of removing non-value added steps from the repair process. During the legacy process there was no incentive for AIMD to go above and beyond to repair the more difficult or time consuming parts. When the FRC's combined the depot and intermediate levels an incentive was immediately created. AIMD could no longer push the parts at will, to the depot by initiating BCM's. Now, protocol demands that each step in the repair process function at optimum. One of the intangible benefits of the COE structure is the personnel that would traditionally receive the BCM are working side-by-side with the personnel that would initiate the BCM. When an AIMD sailor might consider pushing a part to 63X (BCM in the legacy process) because he is not sure of the correct repair, he can now ask the depot artisan for advice, thus potentially preventing the BCM or transferring the part to 63X.

In developing the last two scenarios, there was no future demand forecast available. In lieu of an actual demand forecast, two separate simulations were conducted, one with a 25 percent increase and one with a 50 percent increase in parts arriving. This was created by decreasing the inter-arrival times by the inverse of 25 percent and 50

percent. As in the previous 10 percent increase of parts arriving simulation, we multiplied the legacy inter-arrival times by .8 and .67, effectively increasing the number of parts arriving by 25 and 50 percent, respectively. Both simulations utilized nine CASS benches and a 24-hour work schedule; all other data remained the same as the current state FRC model. The results will be stated and analyzed in Chapter IV.

## IV. ANALYSIS AND RESULTS

To determine the sufficient number of runs for our simulation, an initial 500 replications were run to create a base line. Once the base line was established, the following formula was used to determine the required number of replications,  $n$ :

$$n \cong n_0 \frac{h_0^2}{h^2}$$

where  $n_0$  is the initial number of replications (500 in this case),  $h$  is the desired 95% confidence interval half-width, and  $h_0$  is the initial 95% confidence interval half-width. The average total time-in-system was the measure used for this calculation and with 500 initial runs the initial half-width,  $h_0$ , was 1.83 hours. A desired half-width of  $h=1.0$  hour was selected, which resulted in a required minimum number of replications of 1,674. Therefore, we ran each simulation for 1,700 replications.

### A. NUMBER OF ASSETS OUT

The number assets out represents the number of AVDLR's that would have been RFI'd by the work center. We experienced a slight percentage increase in system output relative to system input in each variation of model. For example, the legacy simulation resulted in 148 assets RFI'd, were as there were 153 assets RFI'd in the current state FRC model. This increase is not surprising because, the newer maintenance structures are more efficient than the legacy structure and are able to RFI at an increased speed with less time spent in system. This results in fewer parts remaining as work-in-process in the newer maintenance structures as compared to the legacy structure. In the models where the arrival rate was increased, the increase in output was slightly larger than the increase in input. In the most extreme scenario, with a 50 percent increase in arriving parts, the number RFI'd increased to 228; a 54 percent increase from the legacy state (Table 4). When analyzing the results of our scenarios, output rate is determined by input rate. A better measure of success is reduction in time-in-system.

MODEL	NUMBER OUT	TIME IN SYSTEM	63E QUEUE	63X QUEUE	RESOURCE UTILIZATION			
			WAITING TIME	WAITING TIME	HI-PWR	RF CASS	SAILOR	DEPOT
LEGACY MODEL	148.47	169.77	4.9128	BCM Delay (hours in sys) 808.19	0.0985	0.1532	0.1492	N/A
COE MODEL	151.92	157.05	4.9538	0.8308	0.1218	0.1572	0.1486	0.1992
10% INCREASE IN PARTS	167.68	157.9	4.9988	0.9687	0.1361	0.1748	0.1645	0.2225
24 WORKING HOURS/9 BENCHES	152.77	137.94	0.00006	1.3136	0.1164	0.1186	0.1342	0.2617
25% INCREASE IN PARTS	191.56	137.56	0.0002	1.8331	0.1481	0.151	0.1686	0.3276
50% INCREASE IN PARTS	227.91	137.14	0.0004	2.4521	0.1781	0.1813	0.2004	0.3899

Table 4. Summary of Simulation

## B. TOTAL TIME IN SYSTEM

The total time-in-system was expressed in hours. There are five main comparisons when analyzing all scenarios. The most significant comparison is the legacy model to the FRC model. There's over a 12 hour decrease in time-in-system when utilizing the FRC process. When increasing the number of parts arriving to the FRC model by 10 percent, and keeping working hours and resources the same, there was no significant change in time-in-system. The next significant change in time-in-system was when labor hours were increased. In the legacy, FRC, and FRC with 10 percent increase in parts models, FRC West had 24-hour coverage, but only five days a week. The next three scenarios represent a 24/7 work schedule with an additional CASS bench and increase in arrivals. When working hours were changed to 24/7 coverage, time-in-system was reduced by 32 hours from the legacy to the 24/7 model and time-in-system was reduced by 19 hours from the FRC to 24/7 model. In the last two scenarios, the same 24/7 work schedule was maintained, but the parts arriving were increased by 25 and 50

percent. As with the FRC model, when arrivals increased by 10 percent, there was no significant change in time-in-system. With a 50 percent increase in arrivals, we experienced less than one minute reduction in time-in-system (Table 4). This steady reduction in average time-in-system directly represents the efficiencies of the FRC maintenance structure. The reduction in time-in-system between the legacy and FRC models is largely explained by the removal of the external BCM process. This affirms the efficiencies realized by combining the depot and intermediate levels of maintenance. The explanation for the reduction in time-in-system between the FRC model and models with 24/7 working hours and increased arrivals is due to increased working hours, resulting in more bench operating times and parts not having to wait over the weekend. One of the main purposes of this project was to determine how the turn-around-time improved with incorporation of the FRC maintenance structure. The time-in-system analysis illustrates a 32-hour decrease in time-in-system when incorporating the FRC structure with a 24/7 work schedule. This holds true even with a 50 percent increase in the number of parts arriving.

An additional comparison of time-in-system reduction is the comparison of 63D BCM delay process to the 63X repair process. In our first comparison of legacy to the FRC model, we are able to equate work center 63E to 63D between both systems, since they are modeled identically. Because the legacy system does not have a depot work center, we compared the BCM delay time with the 63X repair process. Figure 4 illustrates how the 63X repair process replaced the BCM delay in the legacy process, prior to FRC implementation. The Arena models do not directly calculate the time to cycle a part through the 63X repair process, but it can be inferred that the 19 and 32-hour decrease in time-in-system can directly be contributed to replacing the BCM actions within the 63X repair process. As previously mentioned, the interdiction of BCM's is one of the primary benefits of the FRC/COE maintenance restructuring. The BCM delay to 63X queue comparison illustrates this benefit by reduction in time-in-system. This is explained by the removal of non-value added steps in a traditional BCM. In the FRC concept, if a sailor in 63E is unable to RFI the asset, he turns it over to the depot artisan in 63X that is working next to him. In the legacy system, when the decision to BCM is

made, the part is returned to AMSU for processing. Once AMSU received the NRFI asset, they turn it over to supply who in turn ships it off to the depot repair site. The depot repair site is not necessarily co-located with the AIMD. In many cases, the depot is located in a different state or sometimes different country. Once the part is received at the depot, it is repaired on a schedule as dictated by a fiscal contract negotiated by the Naval Inventory Control Point (NAVICP). Once the local supply ships the NRFI asset to the depot, NAVICP fills the deficit at the local supply by either directing a transfer from another supply activity, waiting for the depot to repair one, and in the most extreme cases funding will be increased to the depot to exceed the previous contracted repair schedule. Removing the wasted steps of this lengthy process is the overriding success of the FRC structure. In the FRC design parts are repaired on a first-in first-out basis and not on a fiscal schedule.

### **C. TIME IN QUEUE**

We were only able to analyze the 63D/E queue waiting times. It would not be fully accurate to compare the legacy BCM process to the 63X repair process. This difference was explained in the time-in-system analysis. In analyzing the 63D/E queue waiting times, we found two interesting results. First, there was virtually no change in queue waiting times for the legacy, FRC, and FRC with ten percent arrival increase models. We didn't experience a change in queue waiting times until working hours were changed to 24/7 coverage. Prior to the implementing the 24/7 working hours there was 4.9 hours of queue waiting time. Once the 24/7 work schedule was implemented, the queue waiting time was virtually eliminated. This held true even with the 25 and 50 percent increase in arrivals. The second result was that the implementation of the 24/7 work schedule had the opposite effect on work center 63X. Work center 63X's queue actually increased when the working hours changed to 24/7. This increase in queue waiting time is explained by the limited number of personnel assigned to work center 63X. When FRC West went to four 12-hour shifts as explained in Chapter III, section D2, the four workers assigned to 63X had no flexibility. There were four shifts and only four workers, resulting in only one worker being assigned per shift. Work center 63X is comprised of civilian labor and subject to union rules. A one-hour lunch break was

incorporated into the models. The requirement to have one worker assigned to one CASS bench essentially resulted in 63X losing two hours of production each 24-hour period. The CASS bench would remain idle while the artisan took his lunch break.

#### **D. SCHEDULE RESOURCE UTILIZATION**

To limit the complexity of the models, we modeled the most significant resources; Hi-PWR CASS, RF CASS, AIMD Sailors, and Depot Artisans. As expected, the utilization of these resources increased in conjunction with the increases in the number of arrivals. There was a moderate increase in utilization from legacy to the FRC model due to work center 63X pulling a drain on resources. Prior to FRC implementation, 63D would BCM parts to the depot at another location. Now those parts are repaired in-house by work center 63X which utilizes the same CASS test benches as work center 63D/E. However, there was a larger increase in utilization from the FRC scenario compared to the 24/7 work schedule, 25 and 50 percent increase in parts scenarios, with the exception of sailor utilization (Table 4). This increase in sailor labor utilization is explained by designating seven sailors per shift with nine available CASS benches. The 96 percent increase in depot artisan utilization is explained by the same reasoning as the increase in 63X queue waiting time.

#### **E. UTILIZATION RATES**

There is a disparity in utilization and the actual percent of documented labor, we summed all the IW times directly from NALCOMIS for the sample period and divided by the actual number of labor hours. This resulted in a utilization of 22.36 percent for actual labor and 15.53 percent utilization in the Arena model (Table 5). The significance of the 15.53 percent utilization rate is the best case scenario the model will only yield 15.53 percent labor utilization. When examining the output results in Table 4, there is clearly lower utilization than expected. This is a result of data collection as explained in Table 2. Each process throughout the simulation requires only one worker. During the actual maintenance, the LPO may assign an additional worker to the bench for training, but for the purpose of modeling true capacity, we limited the repair process to one worker per bench. Thirty-one personnel are assigned to 63E, but only twenty-one were utilized in the

model to represent the estimated number of personnel available to run a CASS test bench. The remaining ten account for personnel that are absent from the work place, such as leave, school, temporary assigned duty, watch, etc. In addition to accounting for personnel that are absent from the work place, the remaining ten also accounts for personnel that are not engaged in actual hands-on labor, such as supervisors as explained in Chapter III Sections C and D. For the workers that are actually working on the benches, it is estimated that you only receive 6.62 hours of actual labor in an eight-hour work day (OPNAV). In the legacy simulation, FRC West worked three overlapping shifts of maintenance, four days per week and duty section on Friday, therefore it is estimated that you receive 8.6 hours of actual labor per worker in a ten-hour workday. The labor was based on 65 work days (13 weeks\*5 days/week). Additionally, labor was discounted 15 percent to account for things such as restroom breaks, chow breaks, smoke breaks, etc... Based on these calculations there were 9,676.49 actual labor hours available ( $21 * 8.5 * 65 * .85$ ). In the Arena simulation there were 13,650 labor hours available. The explanation for the increased hours in the simulation is due to the model running continuously and labor not being discounted by 15 percent.

<b>Historical Labor Estimate</b>	<b>Arena Model Labor Estimate</b>
21 Personnel	21 Personnel
10 working hours/day based on a ten hour work day	10 working hours/day based on a ten hour work day
8.5 working hours/day based on a ten hour work day	Model does not account for actual discount
65 Work days (13 weeks*5 days/week)	65 Work days (13 weeks*5 days/week)
11,602 Total Labor hours	13,650 Total labor hours
9,481.98 Total Labor Hours (Discounted 15% to account for actual availability)	Model does not account for actual discount
22.36% based on 2120.52/9,481.98	15.53% based on 2120.52/13,650
Note: Data is based on the sum of all in-work times pulled directly from NALCOMIS resulting in 2120.52 hours actually documented on work orders	
Table 5. Labor Calculations	

**F. CHAPTER CONCLUSION**

In the analysis we illustrated six scenarios:

1. Legacy bases on 8 CASS benches and three ten overlapping shifts working five days per week
2. FRC based on legacy inter-arrival times and working hours
3. FRC based on legacy inter-arrival times, legacy working hours, and with an added 10 percent increase in parts arriving
4. FRC based on legacy inter-arrival times, but with a 24/7 work schedule and one additional CASS test bench.
5. FRC based on legacy inter-arrival times, with a 24/7 work schedule, one additional CASS test bench, and a 25 percent increase in parts arriving.

6. FRC based on legacy inter-arrival times, with a 24/7 work schedule, one additional CASS test bench, and a 50 percent increase in parts arriving.

These scenarios delineate the benefits of the COE maintenance structure. The results were in alignment studies performed by other entities (Heinauer 2007). Each scenario validated the benefit of the COE concept. It became evident when switching from a five-day week to a seven-day work week; work center 63E's queue was virtually eliminated. In the scenarios where there is an increase in the number of parts arriving, the labor utilization increases above 15.53, which represents the maximum utilization the model can achieve, therefore, the number of sailors available must be increased or they must work longer hours. Our model reflected only seven personnel available to run a CASS bench each shift. In reality, if the number of parts significantly increased supervisors would reallocate labor to ensure all benches were operating to meet demand.

## **V. CONCLUSIONS, RECOMMENDATIONS, AND AREAS FOR FURTHER RESEARCH**

### **A. CONCLUSIONS AND RECOMMENDATIONS**

The COE concept works. The process modeled in Arena which represents the FRC model at FRC West in Lemoore is an accurate depiction of the COE process. The results of the simulation runs, when compared to the legacy model, are in line with the data provided from FRC West and are sufficient evidence to reach this conclusion. We found one of the most significant issues was personnel. In the short run, the current state personnel numbers (31 with 2 additional people in a 24-hour schedule) was sufficient enough to maintain optimal utilization. However, in the long run, the ability to maintain top system performance will suffer. Variables such as leave, schools, and other distracters which diminish performance need to be accounted for in order to have the correct number of personnel to realize peak system performance. The future of the COE will depend on how well it can handle increased workload. With the expected increased workload to be somewhere between 25 and 50 percent, we have shown and are confident that the COE work center will maintain its performance levels as long as manning is not an issue and a sufficient number of CASS benches remain operational. Our model takes into account down time due to scheduled and a small amount of unscheduled maintenance based on data provided by FRC West (Shilling 2007).

In the legacy data, there were 26 parts BCM'd that FRC West had repair capability during the sample period. The cost to BCM the 26 parts during the sampled quarter totaled \$743,361. This results in an immediate tangible yearly savings of \$2.97 Mil (assumes that BCM cost per quarter is the mean = \$743,361\*4 quarters) by utilizing the FRC/COE maintenance structure and interdicting BCM's.

In addition to the immediate tangible cost savings, there are numerous intangible savings. By having the depot artisans working side by side with SEAOPDET sailors, valuable training is being realized and being pushed forward to the deployed aircraft carriers. Additionally by having the depot artisans and FST representative located forward with the fleet, FRC West has initiated a "bad-actor" program. FRC West, in

concert with CSFWP, is tracking all frustrated APG-65/73 parts or “bad-actors”. These parts are only installed in non-deploying aircraft to facilitate constant monitoring. This “bad-actor” program has resulted in valuable research and the development of more in-depth repair procedures. When a part is deemed a “bad-actor”, it undergoes a more rigorous inspecting and testing procedure.

Utilizing Little’s Law, we can also determine the cost savings associated with inventory reduction. Inventory can be reduced by different means. You can increase Mean Time Between Failures (MTBF) or you can decrease Mean Down Time (MDT). The COE maintenance structure clearly reduces MDT by decreasing the turn-around-time (Table 6).

<b>Little's Law (i=rt)</b>			
	<b>Inventory</b>	<b>Arrival Rate (parts/hour)</b>	<b>time (hours)</b>
<b>Legacy</b>	<b>13.175</b>	<b>0.0775</b>	<b>170</b>
<b>COE</b>	<b>10.6175</b>	<b>0.0775</b>	<b>137</b>
	<b>This results in a 19.4% reduction in inventory</b>		
Table 6. Inventory Reduction			

The total cost of NAS Lemoore’s APG-65/73 inventory is approximately \$1M (Killgore 2007). Our model demonstrates the reduction in time-in-system and based on this reduction, we can reduce NAS Lemoore’s inventory by 19.4 percent. This results in a potential cost savings of almost \$200K for NAS Lemoore. The total global inventory cost is \$1.37B (Averell 2007). This equates to a possible savings of \$264.8 million savings for the Navy and Marine Corps.

The cost savings realized from interdicting BCM’s and the inventory reductions positively showcases the true and potential cost benefits of the FRC/COE maintenance concept. These better business practices, along with the incorporation of AIRSpeed management practices, are the avenue to curb spending and recapitalize our future fleet.

We have made the following recommendations to further increase the benefits of the COE concept:

- a. We recommend that the Arena model from FRC Lemoore be modified for FRC Mid-Atlantic in Oceana, VA. By applying the model to a separate, but similar entity, it can be proven that our results are repeatable. We believe that this model can be applied to all COE concepts.
- b. Another recommendation is that a man-power review be completed at each future COE when it is determined that the COE has reached steady-state. This will ensure that the appropriate labor resources are available to meet future demand.

## **B. AREAS FOR FURTHER RESEARCH**

The suggested areas of further research are presented as opportunities to expand on work done during this project. There are numerous areas in which further research may be beneficial. Some suggestions include:

### **1. Utilizing Little's Law we determined a potential 19.4 percent reduction in inventory is possible at FRC West. A more scientific study to determine how global inventory may be reduced is warranted.**

The logistics footprint was significantly reduced by the application of the FRC structure. There is no longer the substantial BCM delay at the depot. In addition to removing the BCM process, AIRSpeed and Lean processes have significantly increased the capacities at the FRC/COE. Even though parts may have to be shipped further, it is believed that the global inventory may be reduced because of efficiencies gained by the FRC maintenance structure. Tracking the WRA and SRA components for the APG 65\73 can identify possible choke points in the supply chain and discover additional ways to reduce inventory.

**2. Forecast future demand for the COE based on CAT II repairs being offloaded from the afloat AIMDs and USMC IMAs.**

Accurate future demand forecasting data was unavailable to us. In order to accurately model any process, accurate and timely forecasting is essential. To become more lean and efficient, the Navy is moving towards the better business practice of the COE maintenance concept. To ensure that our activities do not become too lean, it is vital that accurate demand forecasting exist to ensure optimization and ultimately provide better customer service to the war fighter.

**3. Conduct a comprehensive study to quantify the benefits of the “bad-actor” program.**

The program had not been in effect long enough to gather data for a comprehensive study during the time this research was performed. We believe that that “bad-actor” program is going to result in tangible improvements in reliability, significant cost savings, and increased readiness. As the COE reaches steady state and data becomes available, we recommend a cost benefit analysis be performed to realize the full potential of the “bad-actor” program.

# APPENDIX

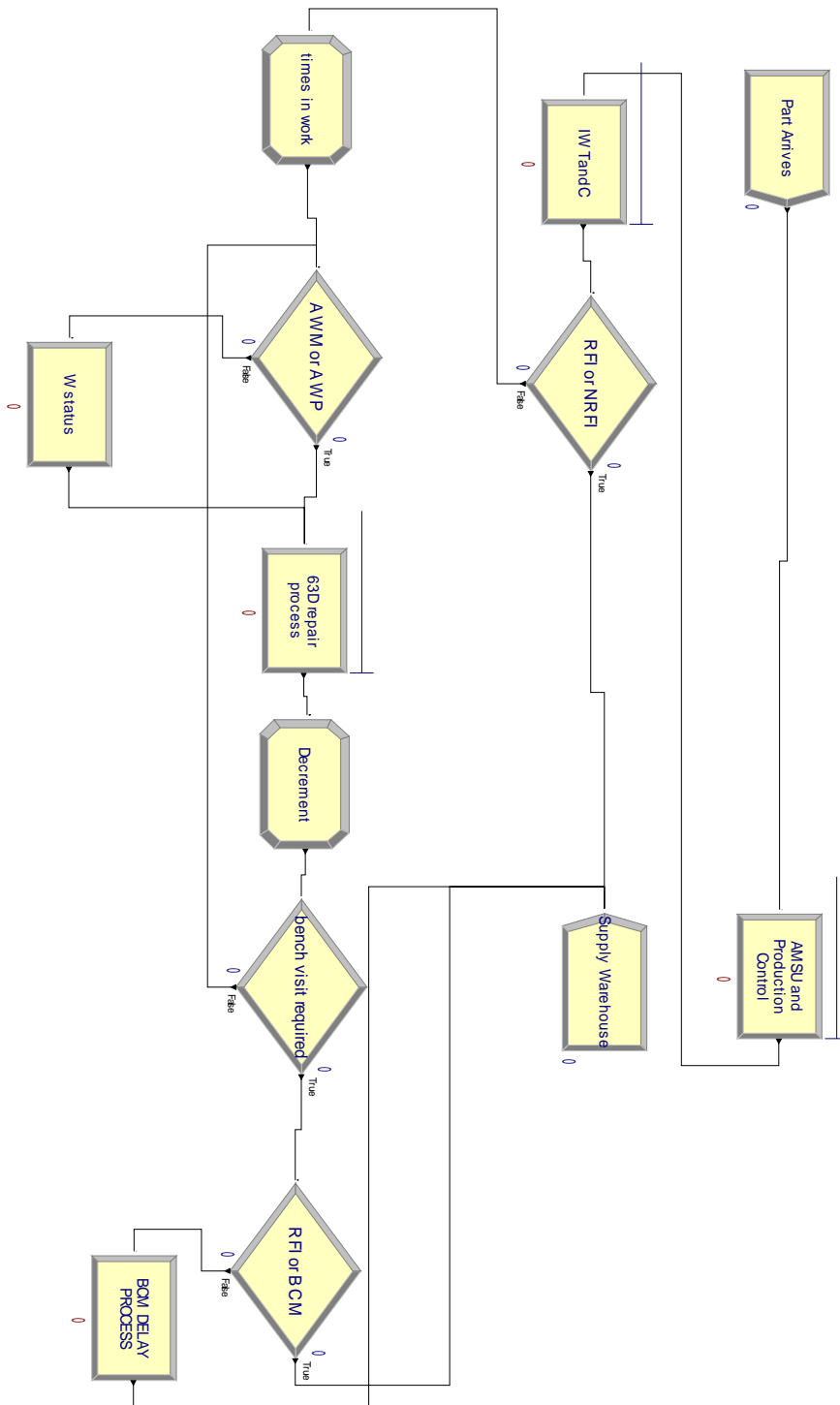

Figure 5. Legacy Simulation Model



<b>Legacy Model</b>			
	<b>Average</b>	<b>Minimum Average</b>	<b>Maximum Average</b>
<b>Number Out</b>	<b>148.47</b>	<b>110</b>	<b>189</b>
<b>Total Time in System</b>	<b>169.77</b>	<b>103.06</b>	<b>248.7</b>
<b>BCM Delay (Legacy Only)</b>	<b>10.41</b>	<b>2</b>	<b>23</b>
<b>Resource Utilization</b>			
<b>Hi PWR CASS</b>	<b>0.0985</b>	<b>0.0666</b>	<b>0.1413</b>
<b>RF CASS</b>	<b>0.1532</b>	<b>0.1095</b>	<b>0.2096</b>
<b>Sailor</b>	<b>0.1492</b>	<b>0.1038</b>	<b>0.2111</b>

<b>FRC Model based on legacy data</b>			
	<b>Average</b>	<b>Minimum Average</b>	<b>Maximum Average</b>
<b>Number Out</b>	<b>151.92</b>	<b>98</b>	<b>191</b>
<b>Total Time in System</b>	<b>157.05</b>	<b>99.89</b>	<b>230.11</b>
<b>63E Queue</b>	<b>4.9538</b>	<b>3.2577</b>	<b>6.7565</b>
<b>63X Queue</b>	<b>0.8308</b>	<b>0.0622</b>	<b>2.9151</b>
<b>Resource Utilization</b>			
<b>Hi PWR CASS</b>	<b>0.1218</b>	<b>0.0812</b>	<b>0.1819</b>
<b>RF CASS</b>	<b>0.1572</b>	<b>0.1051</b>	<b>0.2302</b>
<b>Sailor</b>	<b>0.1486</b>	<b>0.1013</b>	<b>0.2073</b>
<b>Depot</b>	<b>0.1992</b>	<b>0.0442</b>	<b>0.4241</b>

<b>FRC Model based on legacy data and a 10% increase in parts</b>			
	<b>Average</b>	<b>Minimum Average</b>	<b>Maximum Average</b>
<b>Number Out</b>	<b>167.68</b>	<b>129</b>	<b>207</b>
<b>Total Time in System</b>	<b>157.9</b>	<b>104.42</b>	<b>216</b>
<b>63E Queue</b>	<b>4.9988</b>	<b>3.2109</b>	<b>7.0078</b>
<b>63X Queue</b>	<b>0.9687</b>	<b>0.1253</b>	<b>3.4156</b>
<b>Resource Utilization</b>			
<b>Hi PWR CASS</b>	<b>0.1361</b>	<b>0.0897</b>	<b>0.2064</b>
<b>RF CASS</b>	<b>0.1748</b>	<b>0.1153</b>	<b>0.2749</b>
<b>Sailor</b>	<b>0.1645</b>	<b>0.114</b>	<b>0.2178</b>
<b>Depot</b>	<b>0.2225</b>	<b>0.0723</b>	<b>0.4964</b>

**Summary of Simulation Results for Different Scenarios**

<b>FRC Model legacy inter-arrival times but with 24/7 work schedule and additional test bench</b>			
	<b>Average</b>	<b>Minimum Average</b>	<b>Maximum Average</b>
<b>Number Out</b>	<b>152.77</b>	<b>116</b>	<b>204</b>
<b>Total Time in System</b>	<b>137.94</b>	<b>85.8228</b>	<b>211.32</b>
<b>63E Queue</b>	<b>0.00006</b>	<b>0</b>	<b>0.0237</b>
<b>63X Queue</b>	<b>1.3136</b>	<b>0.0283</b>	<b>5.3458</b>
<b>Resource Utilization</b>			
<b>Hi PWR CASS</b>	<b>0.1164</b>	<b>0.0803</b>	<b>0.1593</b>
<b>RF CASS</b>	<b>0.1186</b>	<b>0.0809</b>	<b>0.1723</b>
<b>Sailor</b>	<b>0.1342</b>	<b>0.0911</b>	<b>0.1754</b>
<b>Depot</b>	<b>0.2617</b>	<b>0.0884</b>	<b>0.5878</b>

<b>FRC Model legacy inter-arrival times, 24/7 work schedule, additional test bench and 25% increase in parts</b>			
	<b>Average</b>	<b>Minimum Average</b>	<b>Maximum Average</b>
<b>Number Out</b>	<b>191.56</b>	<b>144</b>	<b>239</b>
<b>Total Time in System</b>	<b>137.56</b>	<b>95.2124</b>	<b>194.55</b>
<b>63E Queue</b>	<b>0.0002</b>	<b>0</b>	<b>0.0174</b>
<b>63X Queue</b>	<b>1.8331</b>	<b>0.2065</b>	<b>8.8451</b>
<b>Resource Utilization</b>			
<b>Hi PWR CASS</b>	<b>0.1481</b>	<b>0.0988</b>	<b>0.1979</b>
<b>RF CASS</b>	<b>0.151</b>	<b>0.095</b>	<b>0.2139</b>
<b>Sailor</b>	<b>0.1686</b>	<b>0.1162</b>	<b>0.23</b>
<b>Depot</b>	<b>0.3276</b>	<b>0.0808</b>	<b>0.6626</b>

<b>FRC Model legacy inter-arrival times, 24/7 work schedule, additional test bench and 50% increase in parts</b>			
	<b>Average</b>	<b>Minimum Average</b>	<b>Maximum Average</b>
<b>Number Out</b>	<b>227.91</b>	<b>176</b>	<b>290</b>
<b>Total Time in System</b>	<b>137.14</b>	<b>97.9575</b>	<b>181.25</b>
<b>63E Queue</b>	<b>0.0004</b>	<b>0</b>	<b>0.0139</b>
<b>63X Queue</b>	<b>2.4521</b>	<b>0.3391</b>	<b>17.0665</b>
<b>Resource Utilization</b>			
<b>Hi PWR CASS</b>	<b>0.1781</b>	<b>0.1217</b>	<b>0.2441</b>
<b>RF CASS</b>	<b>0.1813</b>	<b>0.1233</b>	<b>0.2534</b>
<b>Sailor</b>	<b>0.2004</b>	<b>0.1509</b>	<b>0.2615</b>
<b>Depot</b>	<b>0.3899</b>	<b>0.016</b>	<b>0.0303</b>

**Summary of Simulation Results for Different Scenarios  
(continued)**

## LIST OF REFERENCES

- Averell, Brian. (Dec 2007). E-Mail to the Authors. Deputy Director, Retail Manage Department, Naval Inventory Control Point.
- Beck, B. (Sep 2007). Interview with the Authors. Division Officer, 600 Division, Fleet Readiness Center West.
- Chief of Naval Operations. (2002), *Manual of Navy Total Force Manpower Policies and Procedures*. OPNAVINST 1000.16J, Change 1.
- Commander, Naval Air Forces, Naval Aviation Enterprise. Downloaded June 15, 2007, from <http://www.cnaf.navy.mil/nae/main.asp?ItemID=13>.
- Daniels, D. (Nov 2007). E-Mail to the Authors. COMFRC, Fleet Introduction Team Leader.
- Eckmann, K. (Mar 2007). Interview with the Authors. Executive Officer, Fleet Readiness Center West.
- Hardee, M. (Apr 2007). Telephone Interview. Commander, Fleet Readiness Centers.
- Heinauer, D. (Nov 2007). Telephone Interview, COMFRC, AIRSpeed Director.
- Kelton, W. D., Sadowski, R.P., & Sturrock, D. T. (2007). *Simulation with Arena* (4<sup>th</sup> ed.). New York: McGraw-Hill.
- Kemna, J. (Jun 2007). Interview with the Authors. Commanding Officer, Fleet Readiness Center West.
- Kilgore, A. (Nov 2007). E-Mail to the Authors. Aviation Depot Level Repairables Officer, Aviation Supply Division, Lemoore CA.
- Naval Air Systems Command. About NAVAIR AIRSpeed. Downloaded December 3, 2007. [http://www.navair.navy.mil/navairairspeed/NAVAIRAirspeed\\_about.cfm](http://www.navair.navy.mil/navairairspeed/NAVAIRAirspeed_about.cfm).
- Shilling, R. (Aug 2007). Interviews with the Authors. Chief Petty Officer, 600 Division, Fleet Replacement Center West.
- Steber, D. (Mar/Apr 2006). *Transforming Naval Aviation*. Approach; 51, 2, Military Module, pg. 3.
- United States Department of Defense, Base Realignment and Closure 2005, *Detailed Recommendations, Section 6 Industrial Joint Cross-Service Group IND-1*. Downloaded June 15, 2007, from [http://www.pentagon.gov/brac/vol\\_1\\_parts\\_1\\_and\\_2.html#part2](http://www.pentagon.gov/brac/vol_1_parts_1_and_2.html#part2).

THIS PAGE INTENTIONALLY LEFT BLANK

## INITIAL DISTRIBUTION LIST

1. Defense, Technical Information Center  
Ft. Belvoir, Virginia
2. Dudley Knox Library  
Naval Postgraduate School  
Monterey, California
3. Commanding Officer, Fleet Readiness Center West  
Commander, Fleet Readiness Center West  
Lemoore, California
4. Professor Uday Apte  
Naval Postgraduate School  
Monterey, California
5. Professor Keebom Kang  
Naval Postgraduate School  
Monterey, California
6. Professor Susan Heath  
Naval Postgraduate School  
Monterey, California