

## **Durability Patch: Repair and Life Extension of High Cycle Fatigue Damage on Secondary Structure of Aging Aircraft**

Lynn C. Rogers, Joseph R. Maly  
CSA Engineering, Inc.  
Palo Alto, CA

Ian R. Searle, Roy Ikegami, Wes Owen  
Boeing Defense/ & Space Group

Robert W. Gordon, David Conley  
US Air Force/Wright Lab/FIB; WPAFB, OH 45433

**Presented at The First Joint DoD/FAA/NASA Conference on Aging Aircraft**

### **ABSTRACT**

The Durability Patch Program addresses the repair and life enhancement of nuisance cracks which have been induced into secondary structure by resonant high cycle fatigue from aerovibroacoustics. For this type of damage, safety of flight concerns are virtually non-existent, but maintenance and repair costs are high. Conventional repair techniques consist of mechanically fastened, single sided doublers. For significant static in-plane loads and/or for significant vibration levels due to out-of-plane dynamic loads, the repair does not last long because new cracks will form and emanate from the repair. Eventually, large areas of skin and substructure will have to be replaced. The Durability Patch consists of a bonded repair region which is an elastic elliptical laminate overlaid by and surrounded by a thoroughly integrated damping treatment. In some configurations the transition from the elastic repair region to the damping region is accomplished by the use of a viscoelastic material instead of a structural adhesive in one layer; thus, the other layers are multi-functional. The bonded repair does not introduce stress concentrations, does reduce static and dynamic stresses, and does reduce crack tip stress intensities. The damping further reduces dynamic stresses and stress intensities. Damping is maximized within thickness and area constraints in order to enhance the life of adjoining structure with undetected damage. The life improvement goal is 600x. Finite element analysis results comparing static and vibratory stresses will be presented. High cycle fatigue and crack growth rates will be compared. The design and use of a miniature autonomous damage dosimeter to obtain service temperature and vibration environmental data at low cost will be described. Selection of structural materials and processes to attain a goal of field installation will be described. Comparison of analysis and laboratory results will be presented. Dpatch configurations will be described and compared using a numerical measure of merit system.

# Report Documentation Page

Form Approved  
OMB No. 0704-0188

Public reporting burden for the collection of information is estimated to average 1 hour per response, including the time for reviewing instructions, searching existing data sources, gathering and maintaining the data needed, and completing and reviewing the collection of information. Send comments regarding this burden estimate or any other aspect of this collection of information, including suggestions for reducing this burden, to Washington Headquarters Services, Directorate for Information Operations and Reports, 1215 Jefferson Davis Highway, Suite 1204, Arlington VA 22202-4302. Respondents should be aware that notwithstanding any other provision of law, no person shall be subject to a penalty for failing to comply with a collection of information if it does not display a currently valid OMB control number.

1. REPORT DATE <b>JUL 1997</b>		2. REPORT TYPE		3. DATES COVERED <b>00-00-1997 to 00-00-1997</b>	
4. TITLE AND SUBTITLE <b>Durability patch: repair and life extension of high cycle fatigue damage on secondary structure of aging aircraft</b>				5a. CONTRACT NUMBER	
				5b. GRANT NUMBER	
				5c. PROGRAM ELEMENT NUMBER	
6. AUTHOR(S)				5d. PROJECT NUMBER	
				5e. TASK NUMBER	
				5f. WORK UNIT NUMBER	
7. PERFORMING ORGANIZATION NAME(S) AND ADDRESS(ES) <b>CSA Engineering Inc,2565 Leghorn St,Mountain View,CA,94043</b>				8. PERFORMING ORGANIZATION REPORT NUMBER	
9. SPONSORING/MONITORING AGENCY NAME(S) AND ADDRESS(ES)				10. SPONSOR/MONITOR'S ACRONYM(S)	
				11. SPONSOR/MONITOR'S REPORT NUMBER(S)	
12. DISTRIBUTION/AVAILABILITY STATEMENT <b>Approved for public release; distribution unlimited</b>					
13. SUPPLEMENTARY NOTES <b>Proceedings of 1st Joint DoD/FAA/NASA Conference on Aging Aircraft, Ogden, UT, 8-10 July, 1997</b>					
14. ABSTRACT <b>see report</b>					
15. SUBJECT TERMS					
16. SECURITY CLASSIFICATION OF:			17. LIMITATION OF ABSTRACT <b>Same as Report (SAR)</b>	18. NUMBER OF PAGES <b>31</b>	19a. NAME OF RESPONSIBLE PERSON
a. REPORT <b>unclassified</b>	b. ABSTRACT <b>unclassified</b>	c. THIS PAGE <b>unclassified</b>			

# Durability patch: repair and life extension of high cycle fatigue damage on secondary structure of aging aircraft

L. Rogers(1), J.Maly(1), I.R. Searle(2), R. Ikegami(2), W. Owen(2), D. Smith(2), R.W. Gordon(3), and D. Conley(3)

(1) CSA Engineering, Inc.; 2850 West Bayshore Road; Palo Alto, CA 94303

(2) Boeing Defense & Space Group

(3) US Air Force/Wright Lab/FIB; WPAFB, OH 45433

The First Joint DoD/FAA/NASA Conference on Aging Aircraft

The David Eccles Conference Center; 2415 Washington Blvd; Ogden UT 84401

8-10 July 1997

Letter for clearing for public release due by 23 (was 13) June 1997; printed version of paper due at conference.

Oral Presentation in session titled "Improved Bonding Repair Practices," on Wed July 9 at 1630 hrs

Exhibit Space in number 12, which is in the fartherest left corner as you enter.

## CORRESPONDENCE:

Lynn Rogers, P.E., Ph.D.

Senior Program Manager

CSA Engineering, Inc. (USAF/WL/FIBD/ASIAC)

Area B - Bldg 45 - Room 038

2130 Eighth St at K St - Suite 1

WPAFB OH 45433-7542

Phone: 937-255-4402; fax 937-656-4682; email lynncr@aol.com

**Approved for public release, distribution unlimited.**

# Durability Patch: Repair and Life Extension of High Cycle Fatigue Damage on Secondary Structure of Aging Aircraft

L. Rogers\*   Ian Searle†   J. Maly‡   Roy Ikegami§   Wes Owen¶  
David Smith||   R. W. Gordon\*\*   Lt. D. Conley††

## Abstract

The Durability Patch (DPatch) Program addresses the repair and life enhancement of nuisance cracks which have been induced into secondary structure by resonant high cycle fatigue from aero-vibroacoustics. For this type of damage, safety of flight concerns are virtually non-existent, but maintenance and repair costs are high. Conventional repair techniques consist of mechanically fastened, single sided doublers. For significant static in-plane loads and/or for significant vibration levels due to out-of-plane dynamic loads, the repair does not last long because new cracks will form and emanate from the repair. Eventually, large areas of skin and substructure may have to be replaced. The Durability Patch consists of a bonded repair region which is an elastic elliptical laminate overlaid by and surrounded by a thoroughly integrated damping treatment. In some configurations the transition from the elastic repair region to the damping region is accomplished by the use of a viscoelastic material instead of a structural adhesive in one layer; thus, the other layers are multi-functional. The bonded repair does not introduce stress concentrations, does reduce static and dynamic stresses, and does reduce crack tip stress intensities. The damping further reduces dynamic stresses and stress intensities. Damping is maximized within thickness and area constraints in order to enhance the life of adjoining structure with undetected damage. The life improvement goal is 600X. Finite element analysis results comparing static and vibratory stresses will be presented. High cycle fatigue lives and crack growth rates will be compared. The design and use of a miniature autonomous Damage Dosimeter to obtain service

---

\*CSA Engineering, Inc., 2850 West Bayshore Road; Palo Alto, CA 94303

†Boeing Defense & Space Group P.O. Box 3999, MS 82-97, Seattle, Wa. 98124-2499

‡CSA Engineering, Inc., 2850 West Bayshore Road; Palo Alto, CA 94303

§Boeing Defense & Space Group P.O. Box 3999, MS 82-97, Seattle, Wa. 98124-2499

¶Boeing Defense & Space Group P.O. Box 3999, MS 4X-56, Seattle, Wa. 98124-2499

||Boeing Defense & Space Group P.O. Box 3999, MS 3E-36, Seattle, Wa. 98124-2499

\*\*US Air Force/Wright Lab/FIB, WPAFB, OH 45433

††US Air Force/Wright Lab/FIB, WPAFB, OH 45433

temperature and vibration environmental data at low cost will be described. Selection of structural materials and processes to attain a goal of field installation will be described. Comparison of analysis and laboratory results will be presented. Durability Patch (DPatch) configurations will be described and compared using a numerical measure of merit system.

**Key words:** Passive Damping, High-Cycle Fatigue, Bonded Repair, Cocuring, cocuring, viscoelastic material, composite material, finite element analysis, damping, modal strain energy.

## 1 SUMMARY

The Durability Patch Program addresses the restoration of structural integrity of cracked secondary structure induced by resonant high cycle fatigue. The program is based on adapting technology from three basic areas:

- bonded structural repair,
- vibration damping, and
- avionics.

These three areas each possess a large technology base and have achieved a threshold of maturity sufficient to support this program. A typical repair would be for a crack less than four inches long in 0.050 inch thick skin of the upper trailing edge of a wing. Nuisance cracking is a high maintenance and repair cost item. Typical sources of excitation are: pressure pulses from engine 1st stage compressor, jet engine exhaust, disturbed air flow behind stores, separated flow on upper wing, air flow around open cavities, propeller tip vortices, etc. Typical locations of nuisance cracking are: flap skins, spoiler skins, rudder skins, aileron skins, weapon bay doors, wing trailing edges, etc. Of course there are other possible causes of cracking in secondary or lightly loaded structure besides resonant high cycle fatigue.

## 2 HIGH CYCLE FATIGUE

High cycle fatigue life and crack growth rates are key disciplines in evaluating the longevity of structural repair. Methodology for calculation of resonant high cycle fatigue (HCF, sometimes called sonic fatigue or acoustic fatigue) life and associated crack growth rates used here is well established and consistent with standard industry practice [1, 2, 3, 4, 5]. It has been found that, in most cases, the HCF damage is due to linear resonant response in a single vibration mode; this implies that the vibratory stress is a narrow band random process. The threshold for number of cycles for high cycle fatigue is  $10^6$  (1,000,000) cycles. Fatigue consists of crack initiation, propagation and final rupture. The termination of the

crack initiation phase is somewhat arbitrary since it depends on what is detectable and on what is acceptable in service. The basis for fatigue calculations is the S-N curve

$$S_{RMS} = S_{UHCF} N^b; N = (S_{RMS}/S_{UHCF})^{1/b} \quad (1)$$

where  $S_{RMS}$  is the RMS stress, the coefficient  $S_{UHCF}$  may be considered to be a hypothetical ultimate RMS high cycle fatigue stress which would cause failure at the first cycle,  $N$  is the fatigue life in number of cycles, and  $b$  is the Basquin parameter or exponent. This equation is a straight line when log-log scales are used for stress as a function of life. For 2024 aluminum the value of the exponent (Basquin parameter) is 0.1772 and the value of the coefficient is (98.26 ksi); for these values, a stress improvement factor (SIF) of 2 results in a life improvement factor (LIF) of 50, and fatigue strengths of (8.5 and 2.5 ksi) at  $10^6$  and  $10^9$  cycles respectively. Other aluminum alloys are not much different. Since HCF begins at  $10^6$  cycles, the upper threshold of interest for most aluminums is (8.5 ksi) RMS, or a strain of 850 micro strain RMS. This corresponds to approximately 3000 micro strain peak. Because of stress concentrations, uncertainties in locating strain gages, and averaging effects, measured strains are somewhat less.

It is envisioned that because of the existence of a crack, the life is known and the baseline or unrepaired stress level may be calculated; one objective is to reduce the stress level such that life is enhanced. Stress levels will be reduced through beef-up and through vibration damping using viscoelastic materials(VEM). The RMS stress level is approximately proportional to the square root of modal damping; consequently, damping is a very useful approach for significant vibratory stress reduction. It happens that modal damping is dependent on the dynamic mechanical properties of the VEM, which in turn are dependent on service temperature and vibration frequency. It is therefore necessary to determine the vibration frequency and temperature at which damage accumulates in service. It is assumed that the temperature and stress time histories are available at the location of chronic nuisance cracking.

The analysis is performed for the  $i$ -th frequency band, the  $j$ -th temperature band, and the  $k$ -th time increment. If  $\Phi$  is the Power Spectral Density (PSD) of stress, the RMS stress is given by the square root of the area under the PSD curve.

$$S_{RMS} = \left[ \int_{f_l}^{f_h} \Phi(f) df \right]^{1/2} \quad (2)$$

It may be desirable to calculate the contribution of one third octave (or other) bands

$$\varphi_{ik} = \left[ \int_{f_{li}}^{f_{hi}} \Phi(f) df \right]^{1/2} \quad (3)$$

In this case, the RMS is the square root of the sum of squares, but, because the response

is dominated by only one vibration mode, it may be represented by any of the following, including the sum or a single term

$$S_{RMS} = \left[ \sum_{i=1}^{N_i} \varphi_{ik}^2 \right]^{1/2} \cong \sum_{i=1}^{N_i} \varphi_{ik} \cong \varphi_{ik\max} \quad (4)$$

By substituting this expression for RMS stress into the S-N curve, the fatigue life corresponding to that stress level may be found

$$N_{ijk} \cong (\varphi_{ik}/S_{UHCF})^{1/b} \quad (5)$$

Cumulative damage from different stress levels or time increments may be calculated by using the Palmgren-Miner rule (see Rudder [1] p. 195)

$$d = \sum n/N \quad (6)$$

where  $N$  is the number of cycles to failure at the stress level  $S$ ;  $n$  is the number of cycles actually experienced at stress level  $S$ ,  $(n/N)$  is the damage due to the  $n$  cycles; and  $d$  is the cumulative damage; when  $d = 1$  a fatigue failure is indicated.

Time histories of the temperature and the one third octave bands are recorded

$$T_k, \varphi_{i,k}; i = 1, \dots, N_i; k = 1, \dots, N_k \quad (7)$$

A function may be defined as unity or zero based on whether or not the temperature for the  $k$ -th time increment is within the  $j$ -th temperature band

$$\delta_{T_k, T_j} = \begin{cases} 1; & \text{if } T_k \text{ in } T_j \text{ band} \\ 0; & \text{otherwise} \end{cases} \quad (8)$$

The cumulative damage is given by

$$d_{ij} = \sum_{k=1}^{N_k} n_{ijk}/N_{ijk} \quad (9)$$

The number of cycles is

$$n_{ijk} = f_i \Delta t_k \quad (10)$$

The fatigue life at this stress level would be

$$N_{ijk} = (\varphi_{ik}/S_{UHCF})^{1/b} \delta_{T_k, T_j} \quad (11)$$

with appropriate substitution the cumulative damage may be calculated as a function of vibrational frequency and temperature

$$d_{ij} = \sum_{k=1}^{N_k} f_i \Delta t_k (\varphi_{ik}/S_{UHCF})^{1/b} \delta_{T_k, T_j} = d_{ij}(f_i, \Delta T_j) \quad (12)$$

and the capability to obtain this from service is crucial to the success of this program. The Dosimeter described below addresses this requirement. The above is the cumulative fatigue damage algorithm; it is adapted from standard industry practice and is judged sufficiently accurate for present purposes.

The acoustic noise excitation is typically represented by a broad band random uniform pressure field having a spectral density

$$G_p(f_1) \quad (13)$$

at the fundamental resonance frequency of the skin panel. The spectral density of the response is integrated over the frequency domain to obtain the expression for the mean square stress (see Rudder [1] p194), and the square root gives

$$S_{rms} = (\pi f_1 G_p Q/2)^{1/2} \sigma_0 / P_0 \quad (14)$$

where  $\sigma_0$  is the static stress at the appropriate location produced by the uniformly distributed pressure  $P_0$  and  $Q$  is the modal quality factor or reciprocal of damping. (Some investigators use the fraction of critical viscous damping ratio.)

Substitution leads to an expression for the ratio of repaired and unrepaired (ie, baseline) fatigue lives

$$\left[ \frac{N_R}{N_U} \right] = \left[ \left( \frac{\eta_U}{\eta_R} \right) * \left( \frac{f_R}{f_U} \right) * \left( \frac{\sigma_{OR}}{\sigma_{OU}} \right)^2 \right]^{1/2b} \quad (15)$$

Stresses due to in-plane remote loads as well as stresses due to out of plane loads are of interest. Since the acoustic excitation is modeled as a static uniformly distributed pressure, the stress  $\sigma_0$  will be considered to be a pseudo static and properties of any VEM layers will be taken to be at the appropriate temperature and frequency of the fundamental panel mode. The in-plane loads are much lower in frequency content by comparison, and a value

of modulus for the VEM layer a very low frequency, possibly the value of any rubbery asymptote.

The threshold of high cycle fatigue begins at one million cycles, which corresponds to 8.5 ksi RMS for narrow band random vibration of 2024 aluminum. Without loss of generality, a value for uniformly distributed static pressure may be calculated which results in a static stress of 8.5 ksi; then a value for  $G_p$  may be calculated to make  $S_{RMS_U}$  numerically equal to  $\sigma_0$ . For this situation, the repaired RMS stress ( $S_{RMS_R}$ ) at any point is given in terms of the static stress by the following equation

$$S_{RMS_R} = (f_R Q_R / f_U Q_U)^{1/2} \sigma_{0R} \quad (16)$$

The zero to peak stress will be needed for comparison and is given by a crest factor,  $C$ , multiplied by the RMS stress as follows

$$S_{peak} = C S_{RMS} \quad (17)$$

For the somewhat typical values  $f_U = 200\text{Hz}$ ,  $Q_U = 80$ ;  $f_R = 356$ ;  $Q_R = 5$ ;  $C = 3.00$ ;  $LIF = 600$ ; and  $b = -0.25$ , it follows that

$$S_{RMS_R} = 0.333\sigma_{0R}; S_{peak} = 1.00\sigma_{0R} \quad (18)$$

For a life improvement factor of 600, the stress in the original aircraft aluminum skin  $\sigma_{0R}$  must be reduced to 5.00 ksi or less. If commercially pure aluminum is used in the DPatch, the corresponding stress must be 1.00 ksi or less.

The life improvement factor at any point in the original skin is given by

$$LIF = [0.333\sigma_{0R}/\sigma_{0U}]^{-4.00} \quad (19)$$

It may also be possible to consider stress intensity and rate of crack growth of the repaired crack. Most of the work done in stress intensity has been for in-plane loading whereas the out-of-plane vibration is of interest here.

### 3 SURVEY

In the interests of determining the nature and extent of maintenance and repair costs as a result of nuisance cracking, 126 copies of a survey letter were sent to structural sheet metal shops on flight lines. Additionally, expert personnel visited four flight lines to further assess available facilities, equipment, personnel skills, repair procedures, aircraft operations, etc. One conclusion is that this type of maintenance and repair is not accurately and completely

documented. Typically, the logistics structures engineers are not fully aware of the nature and extent of nuisance cracking.

It was learned that almost all cracks are discovered and repaired before they reach a length of 4 inches. Also, scheduled flying and alert status constrains acceptable maintenance and repair techniques. A new repair technique would not be accepted if it required significantly more man-hours or clock time to implement. A typical small non-flush mechanically fastened sheet metal patch requires two man-hours to complete. This has been accepted as a goal for the present Durability Patch effort.

The total cost of repair of chronic nuisance cracking due to resonant vibration high cycle fatigue for all USAF aircraft is calculated to exceed 20 million dollars/year. Specifically, DPatch is meant to address the restoration of structural integrity of cracked, lightly loaded sheet metal structure where the crack is caused by resonant high cycle fatigue vibration. Structural integrity involves both static load carrying capability and longevity or durability. The visits and the survey confirmed that cracked lightly loaded sheet metal structure is pervasive throughout the US Air Force. Because of the nature of the nuisance cracking, its cost is difficult to quantify. The nuisance cracking falls below the threshold of normal attention from logistics structures engineers. Moreover, often the judgment of a high cycle fatigue expert is required to attribute the crack to resonant vibration with confidence. As a consequence, the typical reporting methods and channels are uncertain as well as incomplete. The approach adopted here is to sample the repair data by visiting flight lines where the repairs are actually performed and interviewing personnel with hands on experience. This approach enabled the dialogue and clarification of any questions with personnel who are the most knowledgeable of the situation. This approach of sampling is considered to be the most reliable available. The letter survey by mail provided general confirmation of the results of the visits.

The set of data is based entirely on professional judgment of the Non-Commissioned Officer In Charge (NCOIC). These cognizant expert personnel in all cases had familiarity and experience of long standing. As such, there was almost no reliance on written records of any type.

It was observed that there is an opportunity for extending the DPatch technology to other types of repair, eg, small arms holes, dropped tools, etc. On occasion, there would be a requirement for filler material to stabilize outer contour face sheets or skin, eg, dents in existing skin.

## 4 DOSIMETER

The Dosimeter has been conceived to gather service environmental data with regard to suspected resonant HCF cracks as economically as practical. Dosimeter requirements are that service data be gathered, processed and stored to permit: the design of a damping treatment (which requires the knowledge of the vibration frequency and temperature at which

damage is being accumulated in service), a valid quantitative comparison of structural life before and after DPatch installation, and any convenient additional diagnostic information.

The Dosimeter is a key component of the process to design and install the most effective patch possible. In order to provide this function the dosimeter must meet several goals:

1. The dosimeter should be simple to install/remove on the widest practical variety of aircraft and locations.
2. The dosimeter should autonomously measure high frequency strain and temperature while the aircraft is operational.
3. The dosimeter should be affordable.

In order to build a useful dosimeter, these goals must be merged with practical cost and operating procedure considerations. As with many other “engineered” products, the finished dosimeter must delicately balance conflicting requirements in order to achieve the best possible performance across the widest variety of aircraft and applications.

In order to achieve these lofty goals a design that is both modular in components and logic has been adopted. Figure 1 diagrams the major logical components in the dosimeter. The first component, the sensors, are comprised of up to three axial strain gages, and a single temperature gage. Both the strain and temperature gages are in-expensive and relatively simple to install. Up to 50 feet of lead wire is allowed between the sensors and the dosimeter processor and power-supply, without adjustment to the sensor gage-factors. This design has several advantages: the dosimeter can be installed by almost any mechanic with strain gage experience, the processor and battery units do *not* have to be micro-miniaturized, and improved signal-to-noise ratio over conventional strain gage signal conditioning methods [18].

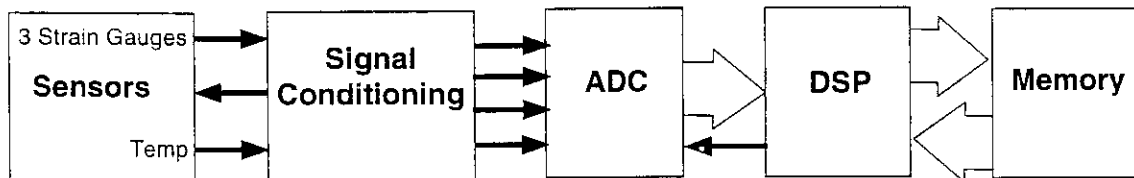

Figure 1: Damage Dosimeter Data/Logic Flow

The processor and data-storage unit is powered by a separate battery for completely stand-alone operation. This has many advantages, and one disadvantage. For advantages there are: the ability to operate on any aircraft, the ability to tailor the battery for different packaging or power requirements, and the ability to install the battery in a location separate (and maybe distant) from the processor and data storage unit. The one disadvantage: batteries low tolerance to cold temperatures, is somewhat mitigated by the ability to install the battery distant (warmer) from the processor unit.

The processor and data storage unit (PDSU) provides several services: autonomous operation, analog-to-digital conversion of the sensor signals, computational operations on the

time-series data, intelligent storage of pertinent data, and communications with a laptop computer for down-loading data, and uploading new programs. The component central to the PDSU is the Analog Device ADSP-2181 Digital Signal Processor (DSP) chip. This DSP chip offers fast integer and fixed-point computations, along with low power consumption. The PDSU contains 4 mega-bytes of flash e-prom for data and program storage. This memory is non-volatile in order to minimize the potential for data loss in the event of low-power or unforeseen circumstances. The PDSU is designed to operate for approximately 12 hours continuously, and up to 2 weeks in mixed operational and standby modes.

Figure 2 shows a two-board configuration for the dosimeter PDSU. In this configuration, the packaged unit will be approximately 5 by 3 by 3 inches in size. Other designs utilize a single board, with the penalty of slightly larger platform.

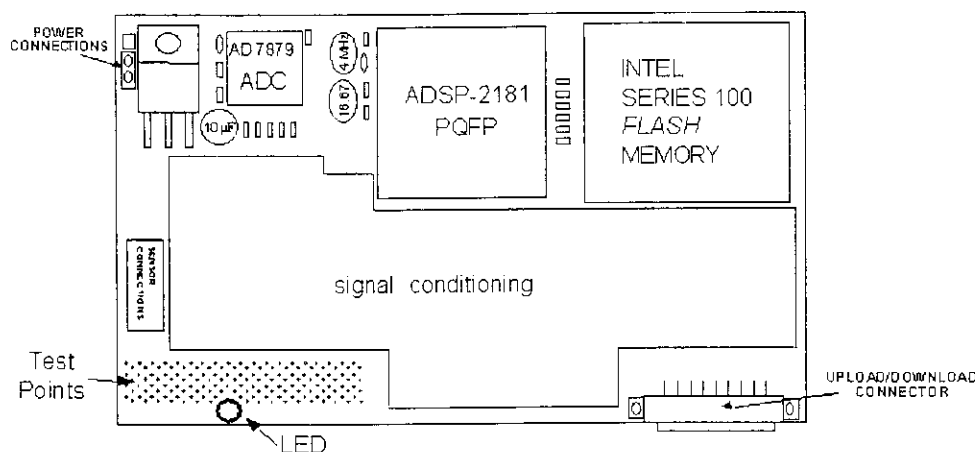

Figure 2: Damage Dosimeter Electronics

Once the dosimeter has been installed on an aircraft, and connected to its battery, it begins its duty cycle. This duty cycle consists of waking itself every 99 seconds, and acquiring one “block” of data. The root-mean-square (RMS) strain levels are computed from the time-series data, if the RMS strain levels are high-enough, then the dosimeter continues to operate until 10 seconds, or blocks, of “quiet” data are recorded. At this point, the dosimeter sleeps for 99 seconds, and then starts the duty cycle all over again. Before the battery voltage level drops to an unsafe operating value, the dosimeter will shut itself down, saving any data it has already recorded.

The dosimeter records a time-history of strain each second, and processes the time-history for the remainder of each second. This method is valid as long as peak value strain detection is not important, which is the case with HCF cracking problems. Typically the structure is responding in a steady-state fashion. From each time-history, the RMS strain in certain 1/3 octave bands is computed, along with minimum, and maximum strain values and temperature. These data are saved in memory, along with “typical” and worst-case sample strain time-histories. The maximum overall level is not expected to exceed 3000 micro strain peak. The frequency range of interest is from 44.7 Hz (the lower limit of the 50 Hz band) to 2239Hz (the upper limit of the 2000 Hz band).

## 5 BONDED REPAIR

The technology base for application of bonded repairs to aircraft structure has achieved a threshold of maturity sufficient to support this effort. Structural repair materials, structural adhesives, surface preparation techniques, design methods, and installation processing and procedures are well established. There are many applications performing satisfactorily in service, many of which are for primary structure. Bonded repair technology is well documented [6, 7, 8, 13]. One recommended design practice is that the patch match the extensional membrane stiffness of the baseline structure in order to avoid load attraction or shedding. Single sided repair results in eccentricity of load which induces bending stresses which must be accommodated.

The design concepts for patches used in bonded repair of primary structure are monolithic and laminated. Structural patch materials are aluminum, fiber metal laminate (FML, eg, GLARE, an aluminum and FG laminate), graphite fiber/epoxy prepreg, and boron fiber/epoxy prepreg.

Applications of bonded repair to primary structure is far more demanding than applications to secondary structure, where there are no significant safety of flight concerns. However, some aspects of bonding are exacting.

## 6 DAMPING

Viscoelastic vibration damping technology has achieved a level of maturity sufficient to support this effort [3]. The stand off damping treatment configuration has been established as possessing very high modal damping performance, high weight efficiency, and significantly less dependent on temperature. Conventional constrained layer damping is flying in service in air flow on external surfaces, some with an edge sealant and some with their perimeter adhesively bonded. The highest practical levels of damping will be used; this will enhance the life of the repaired skin, and will also enhance the life of adjacent bays of skin and substructure. This approach is judged to be appropriate in the context of demonstrated opportunity for improvement in durability with respect to nuisance cracking. Often the intrinsic damping is low; this fact makes the structure more susceptible to resonant high cycle fatigue cracking. This fact also increases the benefits of damping because RMS stress levels are highly dependent on modal damping. The dynamic magnification factor is inversely proportional to the square root of modal damping. The modal strain energy (MSE) has been established as the proper approach to calculate modal damping [9, 10, 11].

## 7 CONCEPTS

The presumption here is that the Durability Patch will be a bonded repair; advantages and disadvantages of bonded and mechanically fastened repair are well established and documented [6, 8], and will not be repeated here. The conventional, baseline repair technique is the mechanically fastened.

The fundamental purpose of the Durability Patch Program is to establish a repair technique for secondary structure (or other lightly loaded structure) which has been cracked due to sonic fatigue. The repair consists of restoration of structural integrity, which implies both static load carrying ability and longevity considerations.

The following design philosophy points summarizes these factors:

- Restore static capability
- Enhance life
- Minimum quality assurance/inspection
- Cost savings
- Ease of installation
- Aerodynamically smooth

To amplify on each of these points, the static capability of the structure must be restored. It is well known in bonded repair that the extensional membrane stiffness of the original skin should be closely matched to avoid load attraction and load shedding. Of course this is true only if the structure carries significant stress. Regardless, the repaired structure must be capable of carrying any applied loads. Since the existence of nuisance cracking demonstrates the opportunity for improvement in durability, the local flexural stiffness should be enhanced in order to better withstand loads.

The life of a properly designed and installed bonded repair will exceed the life of the undamaged baseline structure, although that is known to offer opportunities for improvement. The DPatch must withstand moisture for decades, must reduce stress intensity and consequent crack growth rate, should reduce static stresses, and must reduce dynamic stresses. These points suggest no stress concentrations or hard points, vibration damping, and high tolerance of large disbonds/porosity.

In the interests of aerodynamic smoothness, the maximum thickness will be 1/8 inch, which is negligible with respect to the boundary layer on the aft 80 percent of any surface; also, a beveled edge with a ten to one slope will be incorporated.

The context may be summarized by the following list of points:

- Need for restoration of structural integrity of cracked secondary structure
- Demonstrated opportunity for improvement in durability

- Bonding installation on flight line by inexperienced personnel
- Minor direct consequences of large disbonds
- Opportunity for developing bonding personnel/service experience

Concepts for different aspects of the Durability Patch are listed:

- Prep of crack: stop drill, scarf, seal
- Design: 1-, 2-sided, monolithic, laminated, sandwich (edge: beveled, square. etc)
- Planform: oval, rectangular, fingered
- Perimeter: sealant, integrally tapered core, beveled
- Structural materials: aluminum (2024, 1100, etc; sheet; foil, ribbon, wire), FML, GLARE, fiberglass/epoxy (E or S glass, wet or prepreg), graphite/epoxy, boron/epoxy, quartz/epoxy, etc.
- Sandwich Core materials: syntactic foam, structural adhesive, etc
- Life enhancement: reduce crack growth rate (choice of structural material, laminations, etc), beef-up(ie, reduce static stresses), damping, etc.(ie, reduce vibratory stresses)
- Damping: stand off (spaced) constrained layer; structural adhesive perimeter
- Damping Stand Off Layer (grooved): syntactic foam, structural adhesive, etc
- Structural Adhesives: film: FM73; paste: etc.
- VEM: PSA, bonded, co-cured, etc.
- Surface Prep: abrade paint/solvent wipe, remove paint(hand abrade/power assist), ETC.

There are many advantages to a sandwich repair configuration: increased flexural stiffness reduces the eccentricity of the load path due to in-plane loading; reduced patch bending; reduced bending of the original skin, reduced peel stresses, reduced stress intensity at the crack tip - increased flexural stiffness reduces the curvature of the original skin at the crack due to vibration, reduced stresses skin, patch, adhesive, reduced stress intensity factor for vibration. The feature of primary importance here is flexural stiffness; if the modulus of the repair material is such that there is no thickness available for a core of a sandwich, the flexural stiffness is at a practical maximum.

In one instance a bonded repair patch of thin boron fiber was installed on the external surface of lower nacelle skin; however, the cracks continued to grow [15]. This situation emphasizes the need to consider HCF and crack growth rates of repaired structure.

## 8 CONFIGURATIONS

Several configurations have been defined for a preliminary evaluation of their static and vibratory structural characteristics. The Durability Patch is envisioned to be a quadrilateral

covering two skin panels sharing a common row of fasteners. The perimeter of the two skin panels is a generic "figure 8" which may have curved elements. The test article for this program is described in Section 9. The FEA performed for this trade study is for a clamped-clamped beam representing a strip of the cracked skin panel of the test article. The Durability Patch is also envisioned to include an elliptical elastic repair region over the existing crack, which may, or may not be, overlaid by some damping; in any event the elliptical region will be surrounded by a damping region. In this context, it suffices to describe the through-the-thickness arrangement of the various layers in the repair and in the damping regions.

It is emphasized that these configurations are for repairing structure damaged by out-of-plane, ie, bending, loading; any in-plane loading is quite small by comparison. A lengthy shopping list of various possible features of Durability Patch configurations was considered during trade studies. Several of the desirable features have been incorporated into the 9 configurations selected for further consideration and are described in the Table 1. Configurations with designations beginning with the letter "A" use aluminum as the load carrying structural repair material and configurations "F" use fiberglass, either prepreg or wet. In general, "S" means sandwich, "T" means minimum thickness repair with a damping overlay, and "W" means minimum thickness repair without damping overlay (for comparative purposes). The description of configurations is by layers, not only by DPatch material, but primarily of the finite element analysis model. Layer numbers 1 and 2 refer to the original skin; whereas layers 3 through 7 refer to the Durability Patch. The column designated "Repair" describes the through the thickness lay-up of the region which includes the elastic repair, but may also incorporate damping. In the Figure, the repair region is an ellipse with the "C" designating the location of the crack and "E" designating the edge of the ellipse. The column designated "Damp" describes the damping materials for the overlay. For convenience in FEA (finite element analysis), the thickness remain the same whether repair or damping; actually, in practice, it is also desirable to have the same thicknesses.

In all configurations, the elastic repair region is elliptical. It is adhesively bonded to the original skin centered on the crack location. The elliptical elastic repair region is surrounded at its perimeter by damping, and it may or may not have a damping overlay. The elliptical repair is taken from technology of bonded repair of primary structure. In the repair region, layer 3 of configuration "AS" is a layer of structural adhesive. Layer 4 is 0.025 inch aluminum face sheet. Layer 5 is the core for the sandwich. Layer 6 is also structural adhesive. Layer 7 is the other 0.025 inch aluminum face sheet. With aluminum, the sum of the thickness of layers 4 and 7 (ie, the 2 face sheets) should equal the thickness of the original skin. 0.050 inch in the present case, in order to match the extensional stiffness. In the damping region, layers 3 through 5 are stand off layer (SOL). In practice these would be a single layer; here the 3 layers are retained for convenience in FEA. Layer 6 is VEM (viscoelastic material) which dissipates the vibratory energy and acts as damping. Layer 7 is the constraining layer which causes shear stress and strain in the VEM. Configuration AS2 interchanges the location of the VEM and the SOL. Layer 3 of configuration AT is 0.050 inch thickness, which is the same as the original skin because it is the repair portion. The rest of the repair region and all of the damping region is a damping overlay. All of layer 7 is a constraining

AS	thick	Repair	Damp	AS2	thick	Repair	Damp
1	0.025	Alum		1	0.025	Alum	
2	0.025	Alum		2	0.025	Alum	
3	0.005	SAdh-116ksi	SOL	3	0.005	SAdh-116ksi	vem-100psi
4	0.025	Alum	SOL	4	0.025	Alum	SOL
5	0.065	SOL	SOL	5	0.065	SOL	SOL
6	0.005	SAdh-116ksi	vem-100 psi	6	0.005	SAdh-116ksi	SOL
7	0.025	Alum	Alum	7	0.025	Alum	Alum
AT	thick	Repair	Damp	AW	thick	Repair	Damp
1	0.025	Alum		1	0.025	Alum	
2	0.025	Alum		2	0.025	Alum	
3	0.005	SAdh-116ksi	SOL	3	0.005	SAdh-116ksi	na
4	0.05	Alum	SOL	4	0.025	Alum	
5	0.04	SOL	SOL	5	0.025	Alum	
6	0.005	vem-100psi	vem-100psi	6		na	
7	0.025	Alum	Alum	7			
FS	thick	Repair	Damp	FT	thick	Repair	Damp
1	0.025	Alum		1	0.025	Alum	
2	0.025	Alum		2	0.025	Alum	
3	0.005	SAdh-116ksi	SOL	3	0.005	SAdh-116ksi	SOL
4	0.05	FG-5msi	SOL	4	0.05	FG-5msi	SOL
5	0.015	SOL	SOL	5	0.05	FG-5msi	SOL
6	0.005	SAdh-116ksi	vem-100psi	6	0.005	vem-100psi	vem-100psi
7	0.05	FG-5msi	FG-5msi	7	0.015	FG-5msi	FG-5msi
FT2	thick	Repair	Damp	FT2A	thick	Repair	Damp
1	0.025	Alum		1	0.025	Alum	
2	0.025	Alum		2	0.025	Alum	
3	0.005	SAdh-116ksi	vem-100psi	3	0.005	SAdh-116ksi	vem-100psi
4	0.05	FG-5msi	FG-5msi	4	0.05	FG-5msi	FG-5msi
5	0.05	FG-5msi	FG-5msi	5	0.05	FG-5msi	FG-5msi
6				6	0.005	vem-100psi	vem-100psi
7				7	0.015	FG-5msi	FG-5msi
FW	thick	Repair	Damp				
1	0.025	Alum					
2	0.025	Alum					
3	0.005	SAdh-116ksi	na				
4	0.05	FG-5msi					
5	0.05	FG-5msi					
6		na					
7							

Table 1: Durability patch candidate configurations

layer for damping, whether in the repair region or the damping region. AT is heavier than AS. Configuration AW uses a single layer of aluminum for repair but it is analyzed as two layers. FS, FT and FW are similar to AS, AT and AW except that the thicknesses change because of the modulus of fiberglass. Because of the maximum thickness allowed, there is not enough thickness to include a SOL over the repair in FT. FT2 is a variant of FT which does not include the damping over the repair region and which uses only FG and VEM in the damping region while omitting the SOL to reduce the bill of materials which increases weight by a minor amount. FT2A is a further variant which also eliminates SOL but achieves a maximum damping.

## 9 TEST ARTICLE

It was desired to select a representative structural arrangement to analyze the performance of the above configurations. Typically, when sonic fatigue damage occurs, the crack is located at the center of the long edge of the skin panel, which parallels substructure. The substructure has significant translational and torsional stiffness, although not fully capable of closely approximating clamped boundary conditions. Typically there is a fastener line and the adjoining panel is coupled. There may be a two dimensional array of almost periodic structure. A test article configuration has been chosen to economically represent the most dynamically important of these features. The test article (See Figure 3) is an 8 inch by 17 inch electrical chassis box with 3 inch skirt around the perimeter and formed of 0.050 inch thick aluminum spot welded at the corners. A "T", consisting of two back-to-back aluminum angles, is bonded to the underside of the chassis resulting in one skin panel 8 x 7.5 and the other 8 x 8. The structural arrangement of interest may be visualized as a block "figure 8", with the crack at the "cross bar" between the two skin panels. The structural adhesive used has high modulus and low damping. The high stiffness "T" approximates a clamped boundary while allowing some coupling of the adjacent panel. The bonding minimizes the intrinsic damping, completely eliminating the air pumping and fretting of asperities in a conventional mechanically fastened joint. The bonded joint also eliminates the non-linear out-of-plane vibration of the panel alternately stressing the "heel" of the substructure and the individual fasteners. The modulus of the aluminum chassis is representative of that of aircraft structural alloys.

A more detailed FEA is planned after selecting a few of the configurations from the preliminary FEA. Some of these will be tested for vibration characteristics and compared with FEA results.

## 10 FINITE ELEMENT ANALYSIS

A preliminary finite element analysis (FEA) was performed. The baseline model was a bare clamped-clamped beam 10.5 inches long of unit width, shown in Figure 4. This is

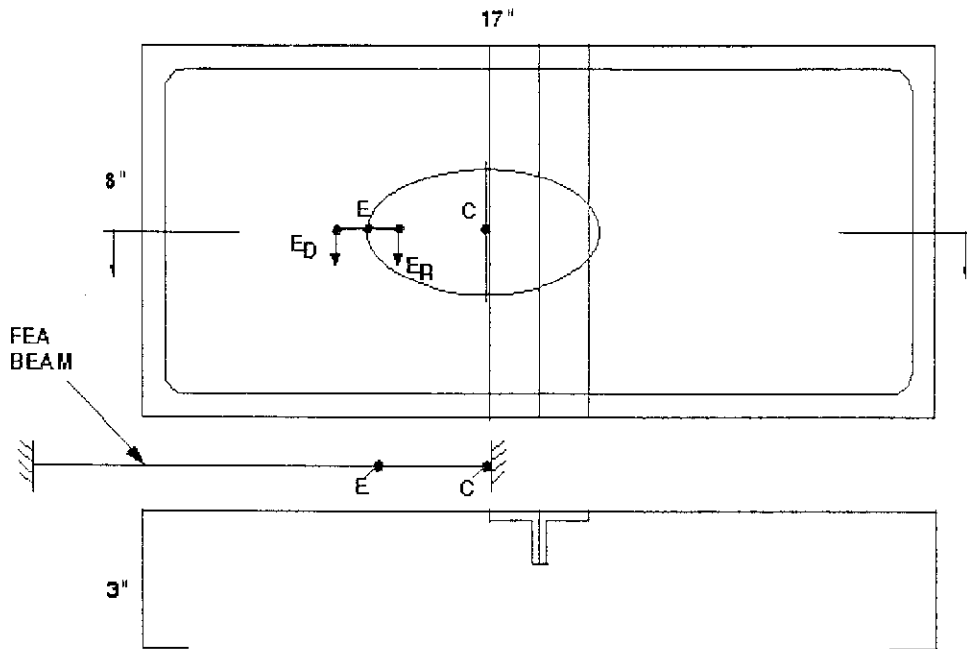

Figure 3: Durability patch test article

representative of a unit width strip of the test article described in Section 9, and shown in Figure 3. One clamped end represents the original skin at the crack location next to the substructure. The elements were 20-noded bricks in all cases. A static uniformly distributed pressure,  $P_o$ , was calculated to result in a maximum stress of 8.5 ksi, which occurs at the crack location, on a bare uncracked beam; this same value of the pressure is used for all out of plane loading. The configurations described above were analyzed on the beam. The repair portion is three inches long, and the damping overlay is another three inches. The next 3.5 inches represents the perimeter surrounding the Durability Patch and the skirt in the direction perpendicular to the crack. The loading conditions are "O" for out-of-plane and "I" for in-plane, which is an arbitrary 10ksi remote uniaxial tension stress. Subcases are "U" for uncracked original skin and "C" for cracked. The crack was modeled as a discontinuity across the entire width of original skin and the adhesive layer, except that one line of nodes for the adhesive retained connectivity. The nodes for the adhesive at the surface of the repair, ie, the plane which contains a surface of layer 3 and a surface of layer 4, are restrained in the in-plane direction. It is noted that there is a possible source of confusion because the "C" designates both the location of the crack and also the cracked configuration. The stand-off-layer (SOL) was modeled as having the properties of being stiff in shear, soft in flexure, and stiff in compression; numerical values were developed in a previous program and used here. The values compare favorably with those of aluminum honeycomb (see Figure 5).

Aspect ratios of one are used at the "C" and "E" locations as well as at the other end of the beam to provide a reasonable degree of accuracy for calculating and comparing stress levels. The same holds true for the cracked cases at the location of the crack in the original skin.

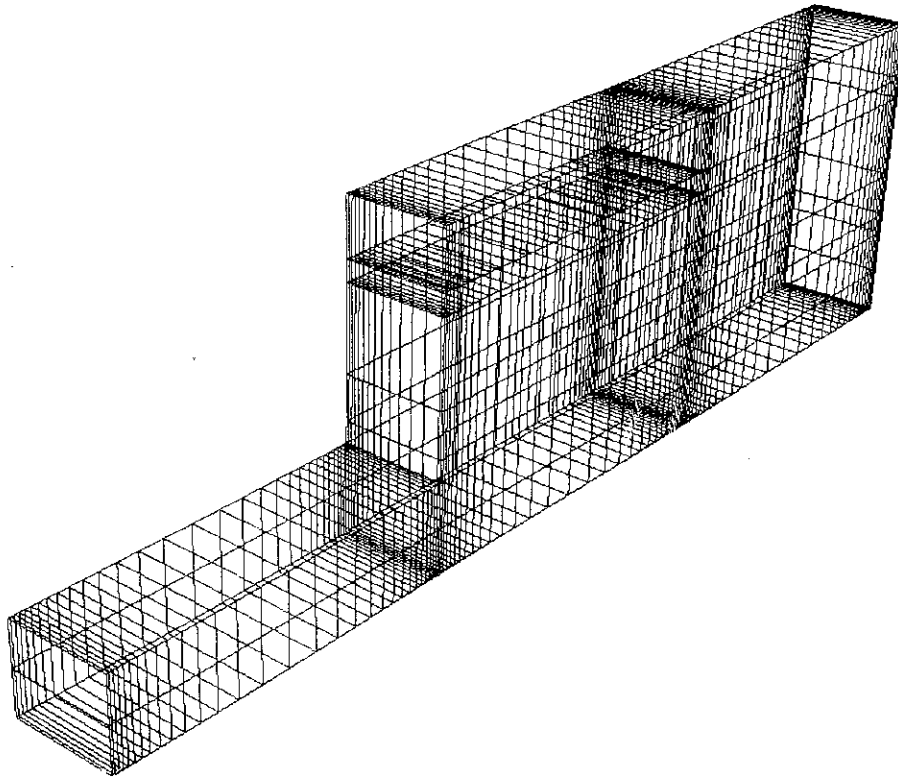

Figure 4: Durability Patch Test-Article Finite Element Model

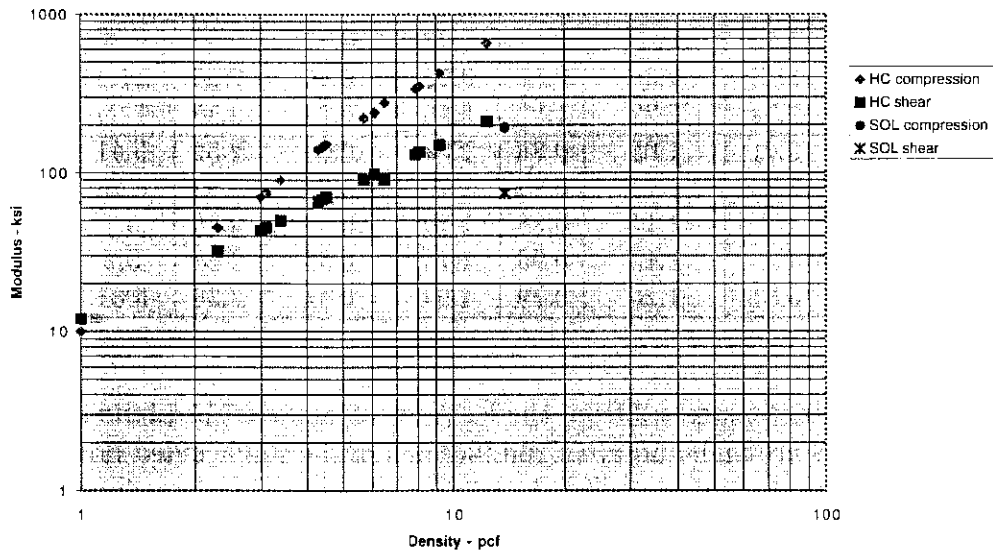

Figure 5: Aluminum Honeycomb and SOL Moduli versus Density

The first three columns of Table 2 gives the maximum stress in the appropriate layers from the FEA. These values are “pseudo-static” (see Section 2). The RMS values are calculated

from them by adjusting for frequency and damping. The zero to peak values may also be calculated using the appropriate crest factor. For all configurations analyzed, the stresses in the original skin are very low and as a consequence have a LIF of significantly greater than 600. (A LIF of 600 results if the HCF crack is detected at 100 hours, and there is a life of 60,000 hrs required.) If there is a skin panel on the other side of the substructure from the crack it will be covered by a portion of the DPatch: it probably has accumulated HCF damage before the DPatch is installed, although it is probably not detectable. It is anticipated that no crack will ever occur in that panel. Any skin panels adjacent to these two will be damped through coupling and will also have their life extended significantly. Also in all configurations, the stress level in the adhesive is well within the linear elastic range; as a consequence, the HCF life of adhesive will be greater than the remaining life of the aircraft. The stresses in the structural load carrying portion of the Durability Patch for the aluminum configurations are higher than desirable for the very mild alloys. The stresses could be lowered by stiffer core material, or aircraft grade alloys could be used to withstand existing stress levels. In the fiberglass configurations, the HCF life of fiberglass will be greater than the remaining life of the aircraft. This allows a configuration to be selected for other criteria. It is attractive to maximize damping to protect adjoining panels.

Table 2: Predicted Stress due to Pressure Loading

	$\sigma$			$S_{rms}$			$S_{peak}$		
	ksi, max pseudo static			ksi, rms			ksi, peak		
	$\sigma_{xx}$ skin	$\sigma_{xx}$ patch	$\sigma_{xz}$ adhesive	$\sigma_{xx}$ skin	$\sigma_{xx}$ patch	$\sigma_{xz}$ adhesive	$\sigma_{xx}$ skin	$\sigma_{xx}$ patch	$\sigma_{xz}$ adhesive
Baseline	8.5			8.5			25.5		
AS	2.42	9.74	0.857	0.81	3.25	0.29	2.42	9.74	0.857
AS2	2.35	9.39	0.824	0.78	3.13	0.27	2.35	9.39	0.824
AT	2.66	11.3	1.38	0.89	3.77	0.46	2.66	11.3	1.38
AW	3.89	17.4	2.22	1.30	5.80	0.74	3.89	17.4	2.22
FS	2.59	5.41	1.05	0.86	1.80	0.35	2.59	5.41	1.05
FT	2.52	5.26	1.14	0.84	1.75	0.38	2.52	5.26	1.14
FT2	2.65	5.1	1.11	0.88	1.70	0.37	2.65	5.1	1.11
FT2A	2.88	5.2	1.13	0.96	1.73	0.38	2.88	5.2	1.13
FW	2.38	5.81	1.26	0.79	1.94	0.42	2.38	5.81	1.26

Table 3 gives the maximum stresses from the FEA for an assumed in-plane loading of 10 ksi. In general, the stresses are high and are a ramification of the single sided repair because load path eccentricity gives rise to secondary bending. In the event that significant combined loading does occur, the mean stresses can be calculated from these values, and then the oscillatory stresses be added as appropriate. For the present purposes of repair and life enhancement of lightly loaded structure, the in-plane loading will be taken as zero. This is a valid approach because the structure of interest is fairings and similar lightly loaded structure where the in-plane loading is very small.

Table 3: Predicted Stress due to Tensile Loading

	ksi		
	$\sigma_{xx}$ skin	$\sigma_{xx}$ patch	$\sigma_{xz}$ adhesive
Baseline	10		
AS	18.6	52	4.65
AS2	-	52.3	-
AT	19.2	39.3	4.66
AW	19.6	69	7.64
FS	18.6	28.2	5.46
FT	17.4	26.4	5.65
FT2	18.1	24.9	5.34
FT2A	17.7	25.3	5.42
FW	17.3	34.1	7.33

## 11 MEASURE OF MERIT

Trade studies reported here were performed at two levels. Initially all configurations (aluminum and FG, wet and pre-preg) were considered. The FT2 and FT2A configurations both wet and pre-preg were selected for further consideration largely on the basis of Bill of Materials. A more nearly complete list of measure of merit items were then used to evaluate the remaining configurations on an absolute scale and to compare them to each other and to the baseline.

Trade studies are performed on results of the analysis of the configurations. Figure 4 – lists the aluminum configurations and both the wet and prepreg fiberglass ones across the column headings. Included in the rows are a Bill of Materials and three qualitative measures of merit. It is immediately obvious that use of either aluminum or stand off layer would require an inventory of several thicknesses. This focuses attention on configurations FT2 and FT2A both wet and prepreg. The prepreg requires cold storage, whereas the wet requires considerable elapsed time and man-hours to prepare. Lay-up of wet FT2A may not be possible because of the thin layer of VEM required, which is very soft and tacky. Prepreg FT2 and FT2A require structural adhesive in contact with the original skin around the perimeter of the DPatch and over the ellipse; this layer may be one piece depending on the co-cured properties of the VEM selected. The FG layers have the advantages of conformability, ease of installation, and aerodynamic smoothness. It also avoids a separate operation of sealing the edges and installing an aerodynamic ramp. At this juncture, the only advantage of aluminum appears to be the possible residual compressive stress from cure and the consequent very low crack growth rates. Disadvantages of aluminum are the lack of conformability for significant thicknesses and compound curvatures and the need to inventory several thicknesses.

The practicality of variations of configurations FT2 and FT2A is limited by damping con-

Table 4: Trade Study Results

	Aluminum				Fiberglass									
	AS	AS2	AT	AW	Wet Lay-up					Pre-preg				
					FS	FT	FT2	FT2A	FW	FS	FT	FT2	FT2A	FW
Bill of Mats														
Dry FG					v	v	v	v	v	-	-	-	-	-
Resin					v	v	v	v	v	-	-	-	-	-
VEM T1	v	v	v	-	v	v	v	v	-	v	v	v	v	-
VEM T2														
Pre-preg FG					-	-	-	-	-	v	v	v	v	v
Struct Adh(Film/paste)	v	v	v	v	-	-	-	-	-	v	v	v	v	v
SOL t1	65	65	40	-	15	105	-	-	-	15	105	-	-	-
SOL t2	95	95	95		70					70				
Alum t1	25	25	25		-	-	-	-	-	-	-	-	-	-
Alum t2			50											
MERIT														
BOM	-	-	-	-	-	-	+	+		-	-	+	+	
Hi damping				-			+	-					+	-
Processes							+	-					+	+

siderations. It is desired to achieve some practical maximum of damping. The thickness of the FG is set by matching the membrane stiffness of the original skin in order to avoid load attraction or shedding; if there is only a small amount of in-plane loading, this criteria is no longer appropriate. However, the maximum damping criteria sets approximately the same FG thickness. For the one original skin elastic layer, then a layer of viscoelastic core, then a second elastic layer consisting of fiberglass, the damping depends on the thickness of the FG layer. Damping is a maximum at a thickness of FG which is approximately the same as matching membrane stiffness. Therefore, configurations FT2 and FT2A are the only practical variations.

An optimum FG layer thicknesses was considered; thicker would require less installation time whereas thinner would allow a closer match of membrane stiffness. The optimum thickness of a layer of FG is considered to be 0.012 - 0.016 inch. Obviously, only an integer number of layers is possible. An even number should be used for sandwich configurations. A practical minimum thickness of aluminum to be repaired is 0.020 inch; using 5 msi as the modulus of FG and 10 msi as the modulus of aluminum means that the ideal thickness of FG is exactly twice the thickness of aluminum. For the minimum gage, that would mean 0.040 FG. For FG layers of 0.016, the choice would be  $2 \times 0.016 = 0.032$  (20 percent under stiff) or  $3 \times 0.016 = 0.048$  (20 percent over stiff). For any thickness of aluminum over 0.020, there is less percentage mismatch in stiffness. For any layer thickness of FG less than 0.016 the same is true. These comments are valid for configurations which are not sandwich, which should have an even number of layers to match face sheets. Figure 6 gives the number of layers of 0.016 FG needed to repair aluminum.

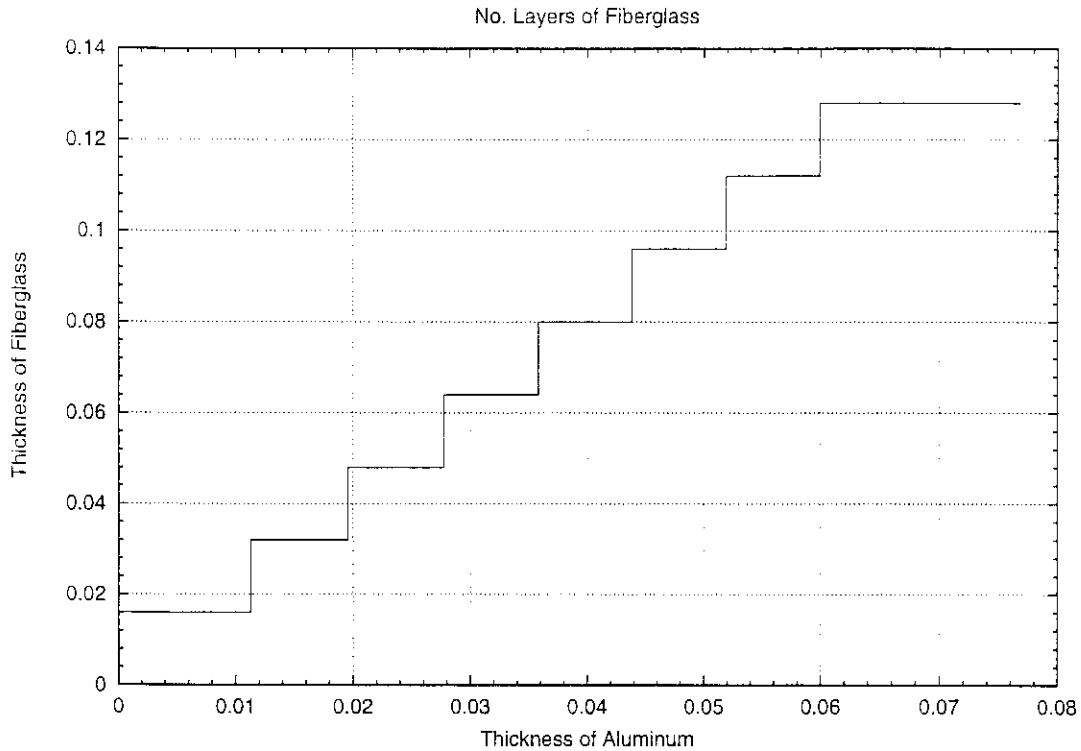

Figure 6: Fiberglass Thickness Required for Aluminum Repair

## 12 PRELIMINARY DESIGN

Preliminary designs of test specimens have been developed to verify performance. The "Chassis-T" is described above. It is planned to utilize fiberglass pre-preg and film adhesive and install configurations of FT2 and FT2A onto a ChassisT. A pattern for cutting all required individual layers of FG, adhesive, and VEM is shown in Figure 7. (Actually the pattern is for a 5x10 DPatch in order that it will fit on a sheet of paper; the one for the ChassisT is 7x16.) For clarity, the planform of the single VEM layer next to the original skin is shown in Figure 8. By referring to the Figure 9 the assembly can be understood. After surface preparation which includes a primer, layer 1 (VEM with elliptical hole) is placed in contact with the original skin with the crack centered in the hole. Note that there is a 0.5 inch wide bonded perimeter. Then FG layers 2 through 7 are installed. For configuration FT2 the outer FG layer, which provides a cap over all other layers and provides the outer edge of the patch (indicated by layer 10 in the figure). For configuration FT2A, layer 8 is another layer of VEM of the same size as the first but without the elliptical cutout. Layers 9 and 10 constitute the constraining layer; it floats (ie, it is not restrained at the edges) except for the single outermost layer. This preliminary design enables the comparison of FEA and experiment. Substantial material and installation cost savings result from this highly integrated, multi-functional design concept.

The Figure illustrates the edge concept. The perimeter of the DPatch should be over sub-

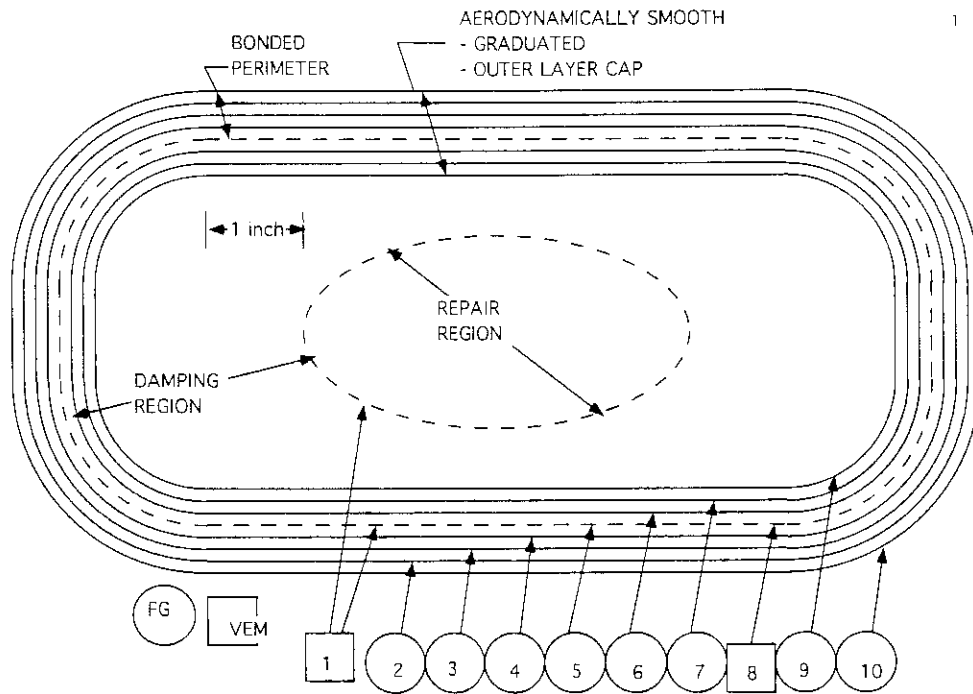

Figure 7: Pattern for Individual Layers of DPatch

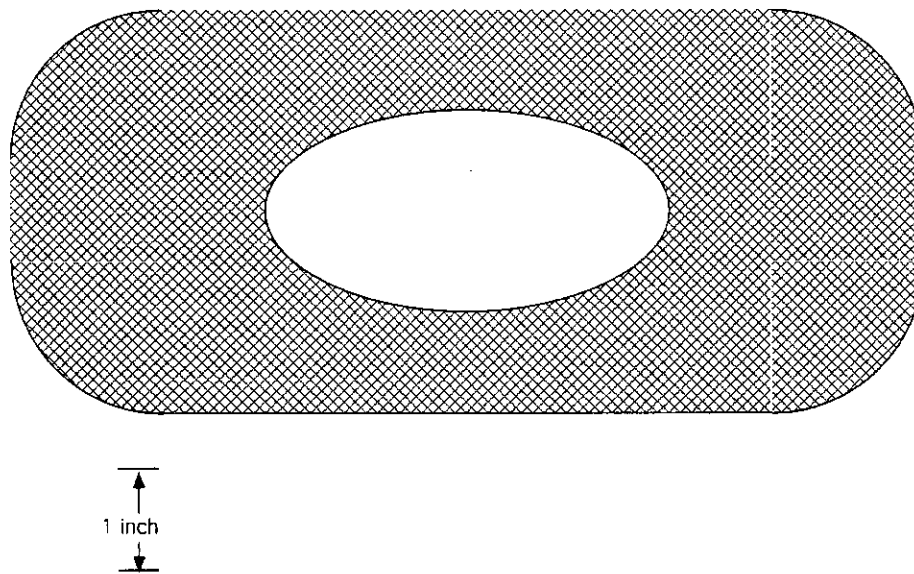

Figure 8: Planform of Viscoelastic Material Layer

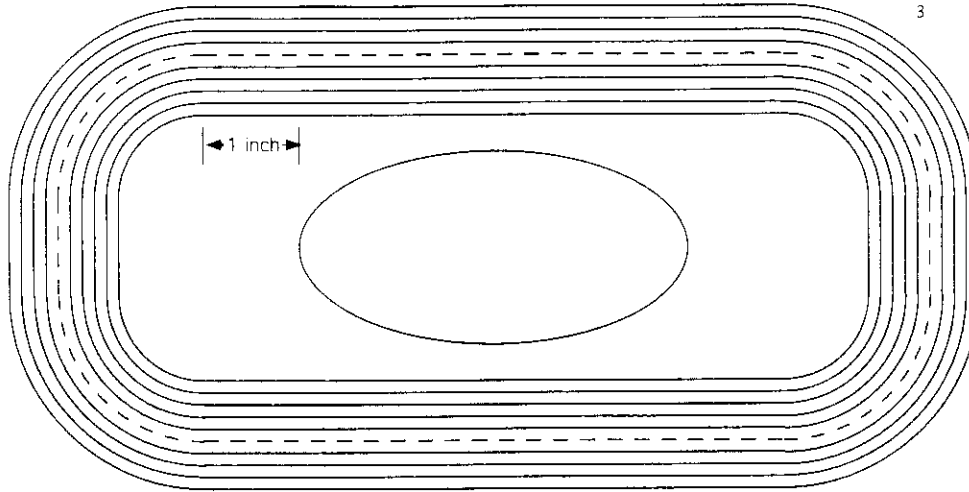

Figure 9: Planform of Preliminary Durability Patch

structure as much as practical while maintaining the aerodynamic smoothness requirement. This serves to reduce stresses in the original skin due to mass loading from out of plane vibration. The area of the DPatch should be a maximum to maximize damping levels. The perimeter of the DPatch is very important; it affects stress level in the original skin, adhesion, aerodynamic smoothness, and cost. The beveled edge achieved through graduated size of layers is a multi-functional design simultaneously providing aerodynamic smoothness and scarf-type of transitional structural loading.

In general, the crack is near the center of the long edge of a skin panel and parallels some substructure. It is considered that there is another skin panel on the other side of the substructure. The fastener line surrounding those two skin panels define a generic "figure 8." These fastener lines may be curved, and the skin may have compound curvature. The DPatch perimeter should extend as close as possible to the inner edge of the outer perimeter of fasteners such that surface prep does not disturb those fasteners. The fastener line representing the crossbar of the "figure 8" would be covered up by the DPatch. The vacuum bag seal would be outside the "figure 8." Procedures could be developed to accommodate fasteners which must be removed. One possibility would be to put a non-porous peel ply next to the original skin and cure the patch in place without VEM, then drill holes in the cured DPatch for the fasteners, then install it with VEM and film adhesive.

A transparent film material with some definite tack and with a 0.1 inch grid would be ideal for use on the aircraft to facilitate determination of the size and shape of the DPatch.

For design of in-plane strength, the tension ultimate times the repair thickness must be greater than or equal to that of the baseline

$$F_{TUR}t_R \geq F_{TUB}t_B \quad (20)$$

to match membrane stiffness it follows that

$$E_R t_R \approx E_B t_B \quad (21)$$

dividing one by the other

$$F_{TUR}/E_R \geq F_{TUB}/E_B \quad (22)$$

leads to the requirement that the tension ultimate divided by the repair thickness must be greater than or equal to that of the baseline; this is satisfied when any aluminum is repaired by any woven fiberglass. In unsupported single lap joints the overlap should be 80 times the thickness of the original skin per Hart-Smith as reported in Baker Jones [6] p 32. When it is considered that in-plane loads for the secondary structure of interest here are a small fraction of ultimate structural capability, the design for static strength is intrinsically satisfied.

It is anticipated that a layer of structural film adhesive will be in contact with the original skin. Next a layer of VEM with the elliptical hole will be put in place. This arrangement provides a maximum of moisture protection of the aluminum surface to adhesive bond. It is also anticipated that a local thickening of adhesive will occur as recommended by Hart-Smith as reported in Baker Jones [6] p 32 at the perimeter of the elliptical repair region.

## 13 MATERIALS/PROCESSES

A goal is that the installation of the bonded repair will be on the flight line at an operational base; this is considered to be somewhere between very challenging and unrealistic/impossible by many experts in bonded repair of primary structure. It is noted that the direct economic and technical consequences of extensive disbonding of a Durability Patch is minor and that this type of repair is a very low profile application. This situation may be used to good advantage in order to maximize benefits.

Very importantly, the DPatch must offer an attractive option (relative to conventional techniques) to the potential user, or it will not be accepted. This means that it must be simple to install, require no more man-hours than conventional repair, require no more clock time, no more requirements for aircraft environment, environmentally safe, etc. It must result in net cost savings with no adverse effects.

The DPatch must withstand moisture for decades. Regardless of any moisture barriers, eventually moisture will intrude into the entire bond line.

In order to minimize costs, there should be a minimum of quality assurance and in service inspection. Measurement and recording of temperatures during cure, and a visual and coin tap afterward are probably the only requirements. No scheduled in service inspection is being considered.

One longevity aspect not yet covered is that of the structural adhesive. Surface prep and adhesive combinations subjected to moisture over decades in service is key to the longevity of the DPatch. At this juncture, the best indication of longevity of the bond line subjected to moisture is the wedge test; criteria is both a threshold of crack growth in the wedge as well as a cohesive failure mode.

It is established above that fiberglass layers is a strong candidate whether wet or pre-preg.

Bonding longevity is indicated by crack growth of the wedge test and also by the necessity of a cohesive failure mode.

Co-cured means that the adhesive is cured in surface-to-surface (not edge-to-edge) contact with the VEM.

On the flight line, the 1750 sealant is currently used much of the time when performing mechanically fastened patches. It is a two part compound and is very messy to use.

The film adhesives being considered are Cytec FM 73, 3M AF 163-2, and Dexter EA 9696, all nominally 250 deg F cure. It is believed that all of these may be cured at a somewhat lower temperature with a minimum sacrifice in mechanical properties and environmental longevity. It is desired to use pre-preg resin consistent with these characteristics.

Achieving 250 deg F on an airplane for cure of the bonded patch to aluminum skin/substructure may be difficult, whereas 200 F is fairly easy. The planned cure temperature will routinely be 250 deg F except when there is a concern about moisture already entrapped in the structure we will cure at 200F for a longer duration. The expectation is that any and all 250 deg F amine (not anhydride) cure epoxy resin for fiberglass pre-preg meeting Boeing BMS 8-79 will be compatible with FM73, AF163, and EA9696.

## 14 DISCUSSION

For convenience and clarity, the nomenclature is changed at this point to distinguish between the FT2 and FT2A wet and prepreg configurations: "WAD" for Wet Augmented Damping (FT2A, not practical for a thin, soft VEM); PAD for Prepreg Augmented Damping(FT2A), PUD is Pre-preg Un-augmented Damping(FT2), and WUD is Wet Un-augmented Damping(FT2).

Table 5 compares the BASE (for baseline riveted patch), PAD, PUD, WAD, and WUD configurations for preliminary qualitative measure of merit criteria. The scores for Materials/Processes and for Support are comparable for all candidates; the Structural Integrity is the discriminator. The longevity, protection of adjoining skin panels, and aerodynamic smoothness are projected to be dramatic improvements. This situation offers an attractive option to the present methods.

Figure 10 qualitatively shows the region of mean and dynamic stresses for indefinite life

after a patch. Stress levels refer to virgin structure being subjected to combined in-plane and out of plane loading. The riveted patch has less static capability than bonded by a very significant amount. The dynamic pseudo static, RMS, and peak stress reduction has a major advantage over the riveted patch. The figure is basically a constant life diagram.

A major benefit of the DPatch is the minimal potential for additional damage because repairs are made in-situ which minimizes handling damage. The Durability Patch Program has additional payoff beyond the program and repair in that service experience for bonded repair and a pool of personnel skills will be developed. Furthermore, experience is provided for future applications of micro data collectors analyzers loggers, eg, health monitoring.

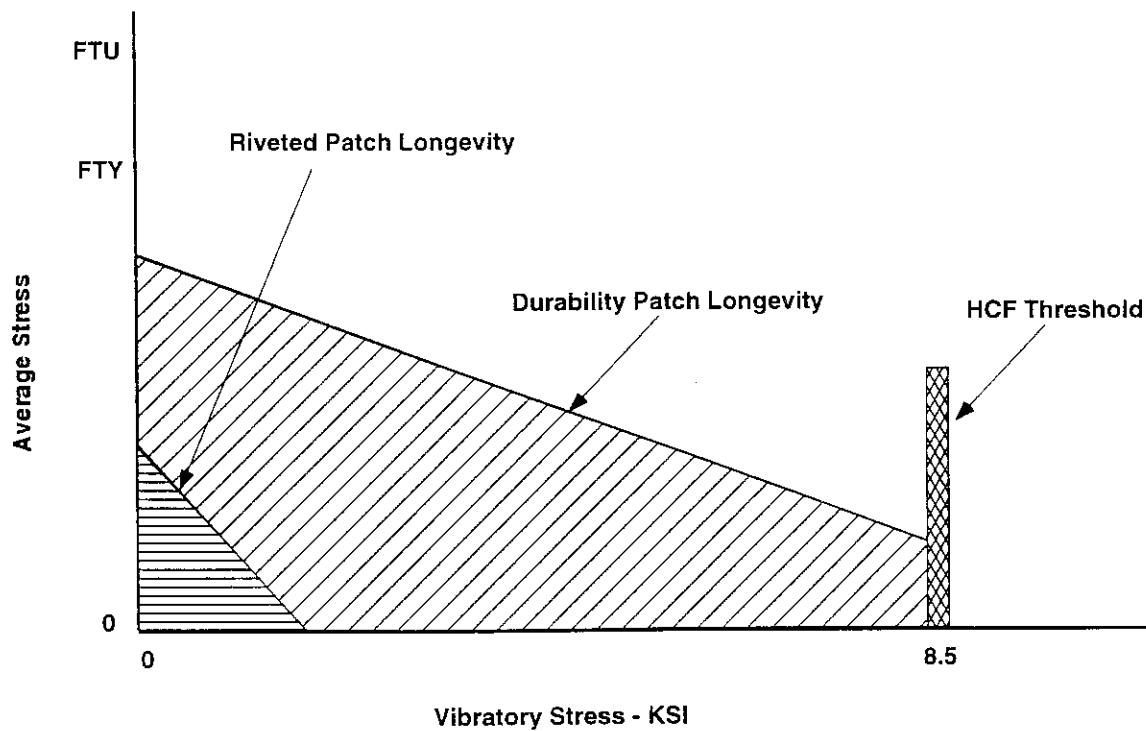

Figure 10: Constant Life Diagram

	Wt	Wt	BASE	WUD	WAD	PUD	PAD
<b>MATERIALS &amp; PROCESSES</b>	40						
Surface Prep/Prime	10		9	6	6	6	6
Cure Temp	10		9	8	8	6	6
Cure Time	20		9	6	6	8	8
Longevity-Bonding	25		9	8	8	8	8
Suscept to induced damage	10		2	9	9	9	9
Aesthetics	5		5	9	9	9	9
Inspectability	10		6	6	6	6	6
Matls Compatability	10		8	6	0	6	6
Score			30.8	28.6	26.2	29.4	29.4
<b>STRUCTURAL INTEGRITY</b>	35						
Longevity-HCF	35		2	6	9	6	9
Protect Adjoin Panels	30		0	6	9	6	9
Aero smoothness	20		1	9	9	9	9
Weight	10		6	5	4	5	4
Static Strength	5		6	8	8	8	8
Score			6.3	23.1	29.575	23.1	29.575
<b>SUPPORT</b>	25						
Tools/Equip	10		6	6	6	7	7
Skill/Ease	10		6	4	4	4	4
Fab Manhours	5		6	5	5	9	9
Elapsed time	20		6	5	5	6	6
Matl Avail/Handability	10		6	4	4	7	7
Hazards/Environment	10		6	6	6	6	6
Cost	10		6	6	6	5	5
Cold Storage	10		10	9	9	5	5
Shelf Life/Out time/Pot life	5		6	5	5	5	5
Training	10		6	5	5	4	4
Score			16	13.75	13.75	14.25	14.25
<b>TOTAL SCORE</b>			53.1	65.45	69.525	66.75	73.225

Table 5: Durability patch candidate configurations

## References

- [1] Rudder, F.F., Jr. and Plumblee, H.E., Jr., "Sonic Fatigue Design Guide for Military Aircraft," USAF AFFDL-TR-74-112. May 1975 (Available from Defense Technical Information Center as AD B 004600). ASIAC 6915
- [2] Byrne, K.P., "On the Growth Rate of Bending Induced Edge Cracks in Panels Excited by Convected Random Pressure Fields," J. Sound Vib. (1980) 68(2), pp 161-171.
- [3] Soovere, J., and M.L. Drake, "Aerospace Structures Technology Damping Design Guide," USAF-AFWAL-TR-84-3089, 3 Vols., Dec. 1985.
- [4] Clarkson, B.L. , "Review of Sonic Fatigue Technology," NASA Contractor Report 4587, NASA Langley Research Center, Hampton, VA, April 1994.
- [5] Wolfe, H.F., Shroyer, C.A. , Brown, D.L. , and Simmons, L.W. , "An Experimental Investigation of Nonlinear Behavior of Beams and Plates Excited to High Levels of Dynamic Response," USAF-WL-TR-96-3057, October 1995.
- [6] Baker, A.A., and R. Jones, eds., *Bonded Repair of Aircraft Structures*, Martinus Nijhoff Publishers, 1988.
- [7] Fredell, Robert S., USAF/DFEM, Academy Department of Engineering Mechanics, "Damage Tolerant Repair Techniques for Pressureized Aircraft Fuselages" 2E WL-TR-94-3134, 1994.
- [8] anon, Composite Repair of Military Aircraft Structures, AGARD CP 550, Oct. 1994.
- [9] Rogers, L. C., R.W. Gordon, and C.D.Johnson "Seminar.on Damped Laminated Beams," unpublished, WPAFB OH, 19 March 1980.
- [10] Johnson, C. D., Kienholz, D. A. ,Rogers, L. C. "Finite Element Prediction of Damping in Beams with Constrained Viscoelastic Layers," *Shock and Vibration Bulletin*, No. 51, pp. 71-81, May 1981.
- [11] Johnson, C. D., Kienholz, D. A., "Finite Element Prediction of Damping in Structures with Constrained Viscoelastic Layers," *AIAA Journal*, Vol. 20, No. 9, September 1982.
- [12] Rogers, L. C.and Fowler, B. L., "Smoothing, Interpolating and Modelling Complex Modulus Data," CSA Rpt, to be published.
- [13] Boeing Repair, to be published.
- [14] L. Rogers, et al, "Durability patch: application of passive damping to high cycle fatigue cracking on aircraft," SPIE Smart Structures and Materials - Passive Damping and Isolation Conference - San Diego CA, Paper no. 3045-28, Mar 1997.
- [15] S.Liguore, R.Perez, and K.Walters, "Damped Composite Bonded Repairs for Acoustic Fatigue," 3rd AIAA/CEAS Aeroacoustics Conference, pp 774, May 12-14, 1997, Atlanta GA.

- [16] R. Callinan, L. Rose, C. Wang, "Three Dimensional Stress Analysis of Crack Patching," ICF9, International Conference on Fracture, Sydney Australia, June 1997.
- [17] R. Callinan, S. Galea, S. Sanderson, "Composite Bonded Repair of Cracked Panels Subject to Acoustic Fatigue," ICCM-11, Melbourne Australia, July 1997.
- [18] Karl F. Anderson, The Constant Current Loop: a New Paradigm for Resistance Signal Conditioning, Technical Memorandum: NASA-TM-104260, NASA Dryden Flight Research Facility, Edwards, CA.

**Acknowledgement:** Support of the US Air Force is gratefully acknowledged.