

J-ROADS Air Defence Simulation Support during the 2006 JPOW IX Missile Defence Exercise

Wouter van der Wiel, M.Sc.
TNO Defence, Security and Safety
Oude Waalsdorperweg 63
2597 AK, The Hague
The Netherlands

wouter.vanderwiel@tno.nl

ABSTRACT

Joint Research On Air Defence Simulation (J-ROADS) is a simulation environment developed at TNO to support air defence research and CD&E for the Netherlands armed forces. It was designed to support three main uses within air defence research: analysis, exercise support and act as a test bed. These three uses are supported by a single simulation environment using modular components with interchangeable fidelity levels. During the 2006 JPOW IX air defence exercise, J-ROADS was used to represent the Royal NL Air Force Patriot, the Royal NL Navy Air Defence Command Frigate, the Royal NL Army Future Ground Based Air Defence System, and Opposing Force air defence regiments based on Russian systems. By connecting the J-ROADS operator-in-the-loop simulation models over a Link-16 network to other simulations and to live systems, a very realistic training environment was created for training and experimentation. Next to the JPOW training scenarios, special experiments were carried out by the Netherlands armed forces to assess the operational value of new interceptor capabilities and new procedures for human interaction on different command and control levels. Very useful results were obtained and new insights were developed by all participants directly contributing to operational concepts, materiel acquisition processes and the further development of J-ROADS.

1.0 INTRODUCTION

The use of Modelling and Simulation (M&S) is increasing in military exercises. It allows for the creation of virtual battlefields where the possibilities for exercises and training are very large. Modelling and simulation adds to creating realism especially in the field of air and missile defence by allowing e.g. virtual launches of (intercontinental) ballistic missiles, warheads loaded with chemicals and exo-atmospheric interceptors. It brings land, sea, air and space based assets together in one scenario for a fraction of the costs of such a scenario in reality.

The current computing technology allows for very effective Concept Development and Experimentation (CD&E) through M&S. The Netherlands armed forces apply CD&E in military exercises such as Joint Project Optic Windmill (JPOW), Europe's leading theatre air and missile defence exercise. TNO supported the Netherlands armed forces with the simulation model J-ROADS during JPOW IX and a long series of previous exercises and seminars. This paper discusses the development of J-ROADS and the TNO support to the Netherlands armed forces with J-ROADS.

Report Documentation Page

*Form Approved
OMB No. 0704-0188*

Public reporting burden for the collection of information is estimated to average 1 hour per response, including the time for reviewing instructions, searching existing data sources, gathering and maintaining the data needed, and completing and reviewing the collection of information. Send comments regarding this burden estimate or any other aspect of this collection of information, including suggestions for reducing this burden, to Washington Headquarters Services, Directorate for Information Operations and Reports, 1215 Jefferson Davis Highway, Suite 1204, Arlington VA 22202-4302. Respondents should be aware that notwithstanding any other provision of law, no person shall be subject to a penalty for failing to comply with a collection of information if it does not display a currently valid OMB control number.

1. REPORT DATE 01 SEP 2006	2. REPORT TYPE N/A	3. DATES COVERED -	
4. TITLE AND SUBTITLE J-ROADS Air Defence Simulation Support during the 2006 JPOW IX Missile Defence Exercise		5a. CONTRACT NUMBER	
		5b. GRANT NUMBER	
		5c. PROGRAM ELEMENT NUMBER	
6. AUTHOR(S)		5d. PROJECT NUMBER	
		5e. TASK NUMBER	
		5f. WORK UNIT NUMBER	
7. PERFORMING ORGANIZATION NAME(S) AND ADDRESS(ES) TNO Defence, Security and Safety Oude Waalsdorperweg 63 2597 AK, The Hague The Netherlands		8. PERFORMING ORGANIZATION REPORT NUMBER	
9. SPONSORING/MONITORING AGENCY NAME(S) AND ADDRESS(ES)		10. SPONSOR/MONITOR'S ACRONYM(S)	
		11. SPONSOR/MONITOR'S REPORT NUMBER(S)	
12. DISTRIBUTION/AVAILABILITY STATEMENT Approved for public release, distribution unlimited			
13. SUPPLEMENTARY NOTES See also ADM002053., The original document contains color images.			
14. ABSTRACT			
15. SUBJECT TERMS			
16. SECURITY CLASSIFICATION OF:			17. LIMITATION OF ABSTRACT
a. REPORT unclassified	b. ABSTRACT unclassified	c. THIS PAGE unclassified	
			UU
		41	19a. NAME OF RESPONSIBLE PERSON

2.0 CD&E AT TNO FOR THE NETHERLANDS ARMED FORCES

In the present fast changing world, the Netherlands armed forces are transforming to incorporate new processes, technologies and capabilities. Key to this transformation are Network Enabled Capabilities (NEC) and Joint Operations, coming together in one of the NEC ambitions of the Netherlands armed forces: *to improve usability & network readiness of the Netherlands defence capabilities in joint, combined & interagency coalitions* [1].

Developing and testing these new processes, technologies and capabilities in the field under realistic circumstances is unpractical and very expensive. Concept Development & Experimentation (CD&E) through Modelling & Simulation (M&S) is an affordable and effective methodology for the experimental development and testing of concepts, theories and capabilities. Modern M&S techniques have brought CD&E in a virtual environment close to CD&E in real environments, but for only a fraction of the costs.

TNO supports the Netherlands armed forces with CD&E on-site at military exercises and in a distributed simulation environment called TNO-ACE (Advanced CD&E Environment). TNO-ACE encompasses four TNO laboratories and integrates knowledge and technology on sensor systems, operational analysis and command & control, weapon systems and munitions, threat and protection, human factors, and information & communication technology. From each of the four locations, TNO scientists can contribute to large scale scenarios or execute local experiments. TNO-ACE can be connected to other experimentation environments outside TNO to contribute to nationally and internationally distributed simulation efforts. The Netherlands armed forces have three centres that offer this possibility: the Command & Control Support Centre of the Royal NL Army, the Centre for Automated Mission Systems of the Royal NL Navy, and the Air Operations Control Station of the Royal NL Air Force.

The two main models used by TNO to create the simulation framework for CD&E are J-ROADS, a simulation model for air & missile defence and network enabled operations, and KIBOWI, a simulation model for the training of army staff officers at battalion, brigade and division level.

TNO's CD&E activities help the Netherlands armed forces to better found the development and procurement of materiel, to learn operational lessons beforehand, and to embed new recourses into the organisation better and sooner. Current examples of TNO support are analyses of the added operational value of the use of unmanned surface vehicles by the Royal NL Navy, added operational value of accuracy improvement of track fusion on plot level versus track level, and development of tactics, techniques and procedures (TTPs) during multi-national extended air defence exercises.

3.0 J-ROADS DEVELOPMENT AT TNO

Joint Research On Air Defence Simulation (J-ROADS) is a simulation environment developed at TNO to support air defence research and CD&E for the Netherlands armed forces. In 2003 the funding for M&S at TNO in the area of air defence became a joint effort between the Royal Netherlands Air Force (RNLAf), Navy (RNLN) and Army (RNLA). This opened the door to the development of an efficient joint simulation environment. The basis for J-ROADS was an existing TNO model called SEAROADS, which had proven itself for years in air defence research in a naval environment. With the development of J-ROADS, air defence research was expanded to the naval, land, air and space environment.

3.1 J-ROADS design philosophy

J-ROADS was designed to support three main uses within air defence research (see figure 1): analysis, exercise support and act as a test bed. These three uses have to be supported by a single simulation environment that uses modular components and has a generic framework to allow for future development inside and outside of air defence. The process of adding components and interchanging components of different fidelity levels must be straightforward. When designing such a large simulation environment, extreme care was taken to achieve a clearly structured and modular environment to accommodate analysis and experimentation in a wide range of applications. This also allows for a large development team to effectively improve and expand the environment.

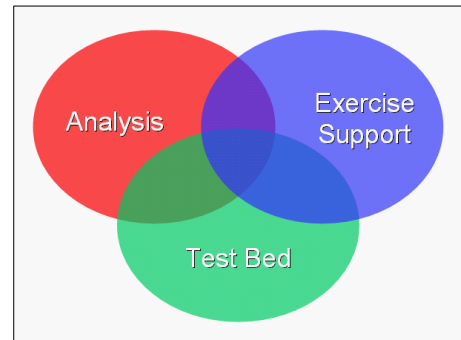

Figure 1: Three main uses of J-ROADS

The requirements for the three uses are overlapping and can be summarised as follows.

- Analysis requires high fidelity system models, detailed data gathering options and analyst user interfaces
- Exercise support requires real-time simulation, medium fidelity system models, simulation network connections and tactical data link connections, in some cases to live weapon systems, data gathering options, and operational user interfaces for the warfighter to control the simulated weapon system operations
- A test bed requires simulation network and direct connections to its (high fidelity) client simulation models or systems, and support functions for those models or systems, such as threat generation, environmental condition generation, supporting weapon system or architecture modelling functionality, simulation visualisation and data gathering and recording

The first step in creating this simulation environment is a simulation kernel that offers all facilities to construct an object oriented, modular simulation. This is a completely independent simulation kernel that manages the flow of time and all interactions between objects that exist in the simulation. It must be able to run at exactly real-time (exercise support requirement), and at accelerated or decelerated time. The kernel allows objects to evolve, die and interact by letting them send triggers to themselves and messages to other objects for events to take place at a certain time in the future. Secondly, it allows objects to exchange and react to information by letting them subscribe to notifications sent out other objects about events that have occurred. The J-ROADS kernel has been developed according to these principles and is used for various simulation applications within TNO.

The second step is to build the simulation framework that provides the possibility to build complex simulation models from generic components, an environment for the simulation models to interact in, interoperability with other systems or simulations, interfaces for users and operators, data gathering and visualisation options, etc. J-ROADS was set up to allow the user to build system platforms from modules, such as weapon and sensor systems, that have a selectable fidelity level and are customised through parameters. The main air defence systems of the Netherlands armed forces, the RNLA F Patriot, the RNLN Air Defence and Command Frigate (ADCF), the RNLA Future Ground Based Air Defence System (FGBADS), have been modelled in J-ROADS to a very high degree of fidelity using a number of especially developed dedicated modules. These modules use the same interfaces to the simulation as their generic counterparts.

Interoperability is a very important aspect of the simulation environment, enabling interaction with other simulations and live systems. Simulations communicate on various levels using a variety of protocols, sometimes over physically separated networks. For military applications this is often divided in a *truth world*, or simulation network connection and a *perceived world*, or tactical network connection. The truth network contains all simulation entities in the scenario and the perceived network contains tactical data such as the tracks of detected simulation entities, platform (status) information and command & control messages. J-ROADS uses DIS and HLA to communicate over the simulation network and Link-16 for tactical communication between platforms within the J-ROADS simulation, and between J-ROADS and external (live) systems.

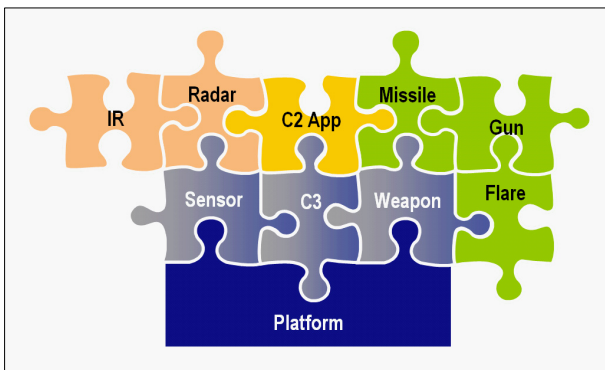

Figure 2: Modular structure of J-ROADS weapon system models

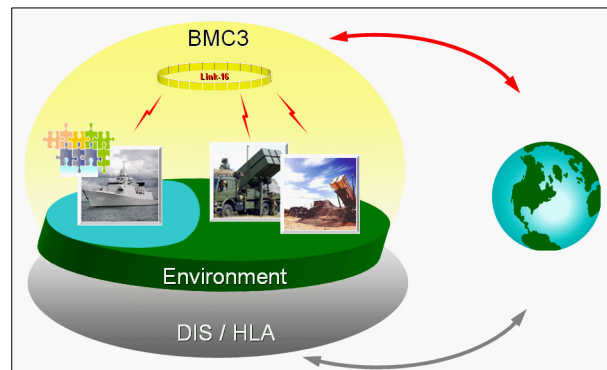

Figure 3: J-ROADS simulation environment for weapon system models

3.2 J-ROADS modular set-up supporting CD&E

Through its modularity and flexibility J-ROADS offers a practical framework for CD&E. It forms a solid basis of simulation capabilities on top of which necessary modules for a certain experiment can be placed. And, as is often the case with developing new concepts, newly developed modules or capabilities can be incorporated with relatively little effort.

In October 2005 the first distributed experiments in the Simulation Environment for NEC Assessment (SENECA) project were performed. The aim of SENECA is to initiate the first Netherlands joint NEC experiment and develop a Netherlands distributed joint experiment environment to combine operational capabilities with simulated capabilities. J-ROADS formed the tactical data link backbone of the experiment with its Link-16 module enabling all participants to use their own type of tactical data link and still create a common operational picture. To accomplish this, the J-ROADS tactical data link module was expanded in a short amount of time with interfaces for Link-1, OTH Gold and CASTOR.

The NATO – Russian Federation Command Post Exercise #2 (NATO – RF CPX #2) was held in March 2005 at AFB De Peel in The Netherlands. Hosted by the Royal NL Air Force, this CPX supported the NATO – RF Theatre Missile Defence (TMD) interoperability project in validating the Experimental Concept and associated Experimental Concept of Operations (CONOPS) developed over the year before by the joint NATO – RF TMD Ad Hoc Working Group. Over fifty participants from several NATO nations and the Russian Federation participated in this exercise. A central role was played by the Coordination Group, which was manned by NATO and RF personnel, see figures 4 and 5. The Coordination Group was responsible for the operational coordination between the NATO and the RF forces. All NATO and RF forces were generated by J-ROADS operator-in-the-loop simulations: NATO and Russian Federation (RF) C2 systems, NATO and Russian Federation land-based lower tier missile defense systems, and early warning systems (NATO satellite and Russian radar).

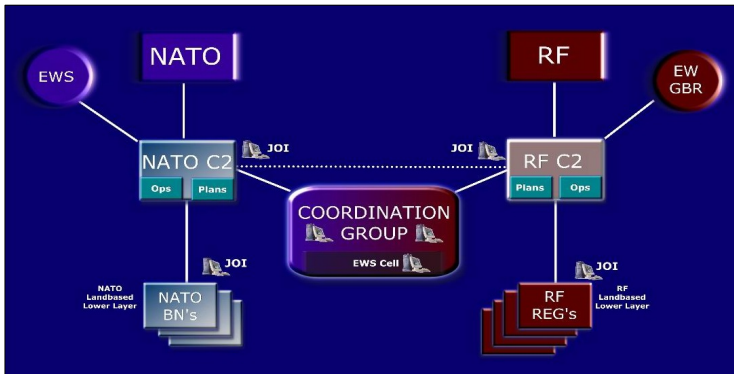

Figure 4: NATO – Russian Federation CPX #2



Figure 5: Coordination Group

During the 2006 JPOW IX air defence exercise J-ROADS was used to represent the RNLA F Patriot, the RNLN ADCF, the RNLA FGBADS and Opposing Force (OPFOR) air defence regiments based on Russian systems. Next to regular operations, experiments were carried out where the operational value was assessed of a new interceptor capability and new procedures were assessed of human interaction on different command and control levels. To accomplish this, the new interceptor capability was modularly added to the weapon system model and a new internal weapon system command and control level was created including a dedicated interactive operator interface. The next chapter discusses the JPOW IX support in greater detail.

4.0 TNO SUPPORT AT JPOW IX

4.1 Joint Project Optic Windmill IX

Joint Project Optic Windmill (JPOW) is a Theatre Air and Missile Defence exercise, organised by the Royal NL Air Force with support of the US European Command, the German Air Force and the US Missile Defense Agency (MDA). Its original aim is to exercise and maximise the interoperability achievements between the three main Patriot users, the United States Army, the German Air Force and the Netherlands Air Force, with emphasis on mission planning and execution on all levels of command and control. Since the first JPOW in 1996 it has evolved into the leading European Theatre Air and Missile Defence exercise, where live air and missile defence weapon systems fight alongside manned simulated weapon systems, all connected to a radio frequency Link-16 tactical network. This combination of live and simulated weapon systems makes JPOW an excellent training environment for joint and combined air and missile defence efforts, and an excellent test bed for near-term future concepts, capabilities, and TTPs.



Figure 6: JPOW IX logo

The ninth edition of JPOW took place in March and April of 2006 on the island of Crete, Greece. Over 1500 participating military and civilian personnel and large amounts of materiel from The Netherlands, the US, Germany, Norway, Greece and NATO made this the largest JPOW to this date. JPOW IX explored the MDA advanced concept of Integrated Missile Defence of boost, midcourse and terminal ballistic missile defence. NATO played a large role by introducing elements of the future Air Command and Control System (ACCS) in the missile defence arena. Besides the traditional JPOW participants such as Patriot, Theatre High Altitude Area Defense (THAAD), Airborne Laser (ABL), AEGIS BMD and the Air Defence and Command Frigate (ADCF), new systems were introduced such as the US Command &

Control, Battle Management and Communications (C2BMC), the RNLAF Patriot Advanced Capability phase 3 (PAC-3) and the German SAM Operations Centre (SAMOC). JPOW IX also focussed on the evolving cruise missile threat by introducing army organic short range air defence systems from The Netherlands and Norway. The cruise missile concept also included new ground based and elevated sensor technology and concepts. The exercise was concluded with the live firing of four Patriot missiles [2].

4.2 TNO support for the Netherlands armed forces

TNO supported the Royal Netherlands Air Force, Navy and Army at JPOW IX with J-ROADS operator-in-the-loop constructive simulations of their air and missile defence weapon systems. J-ROADS enabled the operators to fully participate with their weapon systems in the air and missile defence operations and to be fully interoperable over the Link-16 tactical network with commanding entities, such as the Netherlands and German deployable Control and Reporting Centres (CRC), and with the live weapon systems, such as the Patriot PAC-2 and PAC-3 systems. This allowed the Netherlands armed forces to meet their exercise participation and experimentation objectives. Additionally the Royal NL Army was supported with the air defence planning model INDIA, and the Royal NL Air Force was supported with the hazard area prediction model HAPPIE. Out of roughly ten player cells, or operator-in-the-loop virtual weapon system locations, TNO supported four with J-ROADS. These were the RNLAF Virtual Patriot battalions, the RNLAF OPFOR air defence regiments, the RNLN ADCFs and the RNLA FGBADS.

The RNLAF used three simulated Patriot battalions, operated by a combined crew of Netherlands and German air force operators. Each battalion consisted of a Patriot ICC (Information and Coordination Central) and subordinate ECSs (Engagement Control Station) with a number of launchers each. The operator controls the ICC in J-ROADS where he is presented with both the Link-16 Common Operational Picture (COP) and his local tracks generated by the subordinate ECSs. He has complete control over the weapon system, managing radar settings, missile loads per launcher, engagements, weapon control status, etc. The engagement mode can be set to manual, where the operator has to hook and engage every target manually, to automatic, where an engagement solution is calculated by the computer and all engagements are automatic, and to semi-automatic, where only engagements for certain threat classifications are automatic. The Opposing Force air defence regiments consisted of a great number of missile launching stations. Each regiment was controlled by an operator. These red regiments were present to increase the realism of the exercise scenarios.

The RNLN used two Air Defence and Command Frigates, each consisting of the regular ADCF model extended with an experimental capability. The ADCF has air defence capabilities to protect assets and provides early warning and air surveillance over a wide area with its long range SMART-L sensor. One frigate had the additional capability of exo-atmospheric ballistic missile engagements, and the other frigate had the additional capability of striking land targets in enemy territory using land attack cruise missiles. This allowed the RNLN to assess the value and possibilities of an ADCF with these capabilities in an international coalition, and fully participate in the ballistic missile defence and (time sensitive and pre-planned) counterforce attack planning processes.

The RNLA used a J-ROADS representation of their Future Ground Based Air Defence System (FGBADS). This is a short range missile system capable of countering the cruise missile, tactical missile, UAV and air breathing threat. FGBADS is still under development, so participating with a representation of the system in a realistic air and missile defence environment brings a wealth of knowledge and experience, and is an excellent opportunity to experiment with operational configurations of the system and validate foreseen procedures.

To facilitate operator procedure experimentation, TNO developed distributed J-ROADS simulations for FGBADS to allow multiple operators on different command and control levels to operate the system, see figure 7. In this way the simulation architecture is much more representative of the real FGBADS system.

Two operators manned the FGBADS main command and control station, the Operating Centre (OC), which was in contact with higher echelon and other (live) weapon system through the Link-16 tactical data link and via a voice loop. The FGBADS OC managed both the Recognised Air Picture (RAP) and the Local Air Picture (LAP). The LAP was created by a flexible number of radar systems and subordinate Shorad Fire Control (SFC) stations, optionally manned by an operator or unmanned in automatic mode, that communicate with the FGBADS OC through an internal FGBADS tactical data link (TDL). At the OC remote tracks from the RAP could be dragged to and from the LAP at will, providing the SFCs with early warning while not cluttering their picture with all remote tracks from the RAP.

The J-ROADS simulation of the FGBADS OC is a good example of the flexibility and modularity of the J-ROADS simulation environment. Based on the original FGBADS model, separate models were created for the OC and SFC with dedicated operator interfaces and control capability. These models run on different computers connected through a developed FGBADS TDL network connection. For the FGBADS OC simulation this means it communicated and processed data over three physically separated networks, the DIS simulation network, the Link-16 tactical data network and the FGBADS tactical data network. It displayed and processed input from two dedicated operator interfaces and simulated the FGBADS sensors, an SFC in automatic mode, and all VSHORAD Stinger platoons.

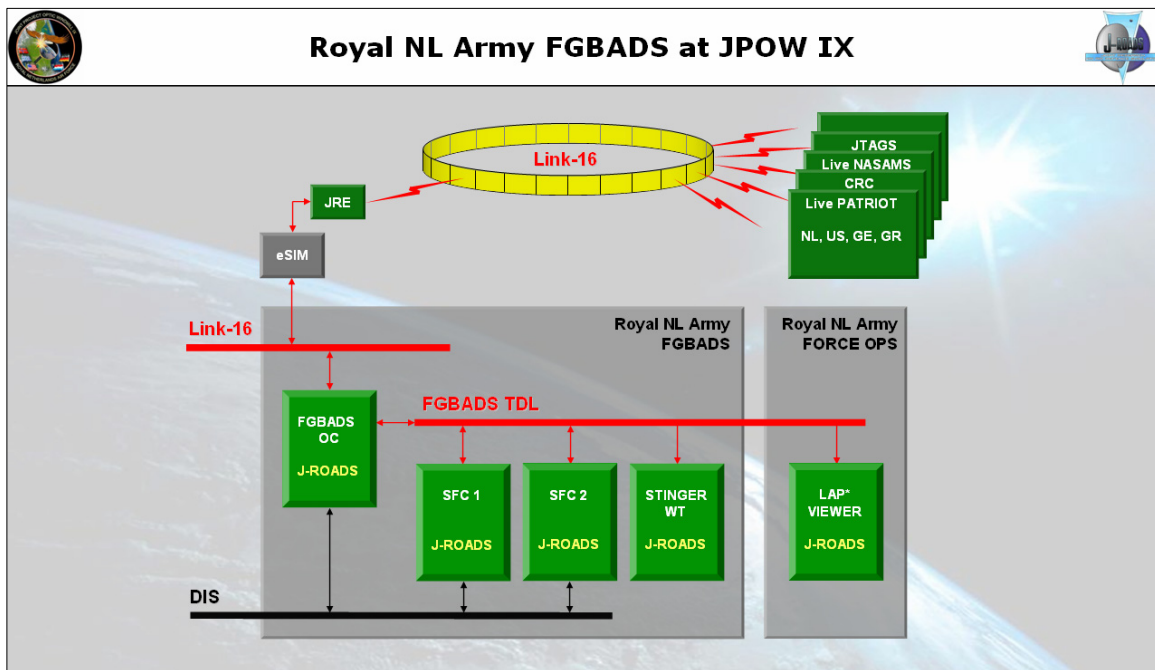

Figure 7: Royal NL Army FGBADS connection diagram at JPOW IX

4.3 Testing and Integration

The testing and integration of the constructive simulations and live systems into the simulation network and especially the tactical network is a challenge. With the lessons learned from the previous exercises new capability is added with each new exercise. JPOW IX featured an impressive Link-16 network set-up and message set, scenarios with hundreds of active entities at any one time and interesting features such as post intercept debris clouds.

Every constructive simulation had to go through an accreditation process before going to the exercise, to ensure that its Link-16 implementation was satisfactory and did not interfere with the live systems. At the exercise location, the first step of the integration process was the one-on-one testing of the systems. All simulation and tactical messages were logged and analysed for correctness and consistency. The second step was the ensemble testing, where all systems were gradually connected to the networks and interoperability was tested and refined.

With a multitude of systems as were connected in JPOW IX, anomalies will happen during testing. J-ROADS undergoes an extensive testing phase at TNO before going to an exercise, but the network architecture at JPOW IX was far too complex to be recreated in a lab. At JPOW IX the constructive simulations were usually less robust than the live systems, but they have the advantage to be adjustable on-site. For a successful integration it is thus paramount to have very knowledgeable subject matter experts (SMEs) on-site to react to all anomalies.

An example of one-on-one testing is a stress test where the J-ROADS simulations were successfully subjected to over a thousand tracks, simultaneously over the DIS network and over the Link-16 network, as shown in figure 8. A peculiar situation occurred in a special situation where an ADCF J-ROADS simulation, a PATRIOT J-ROADS simulation and an external AWACS simulation were interacting over the Link-16 network. The AWACS used the so called “shower down” principle for the tracks it reported on the network, where all tracks are reported independent of other sensors reporting the same tracks with a higher track quality. The ADCF was tracking a number of these tracks with a higher track quality and tried to take over reporting responsibility for these tracks from the AWACS, according to STANAG rules, while the AWACS ignored the attempts because of its “shower down”. The consequent repeated attempts of the ADCF to acquire reporting responsibility triggered the creation of ghost tracks at the PATRIOT. Figure 9 shows the ghost tracks on the tactical data link in the J-ROADS operator interface. This anomaly was subsequently corrected.

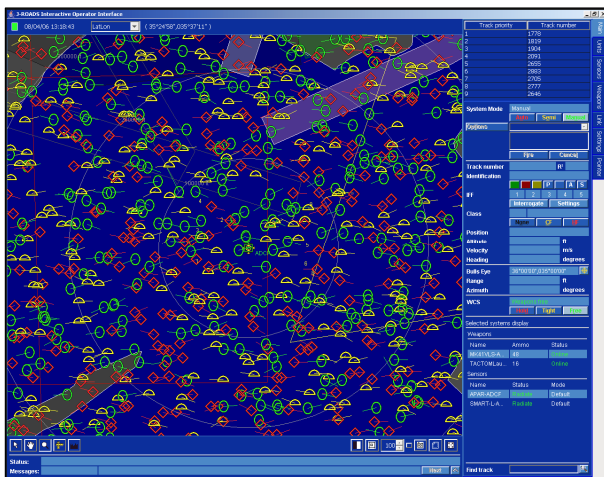

Figure 8: J-ROADS stress testing during JPOW IX

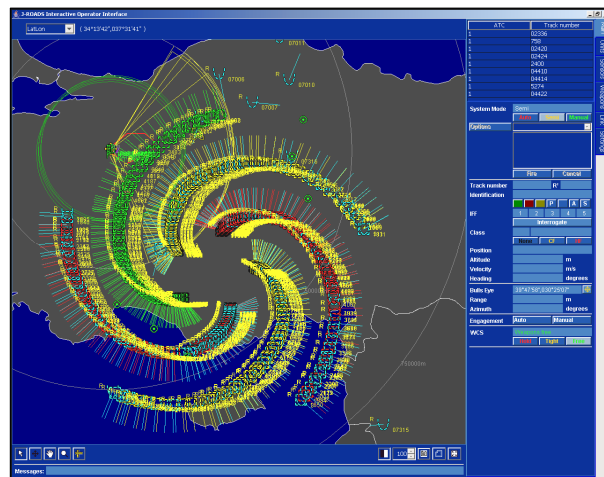

Figure 9: Ghost tracks in operator interface

4.4 Exercise and experimentation

During the exercise phase of JPOW IX, daily eight hour scenario runs were executed, reflecting the evolving situation of the red force and blue force campaigns. Defence designs based on the Coverage Mission Order (CMO) and Air Tasking Order (ATO) released by the Tactical Air Operations Centre (TAOC) were executed, analysed and reviewed. Operators manning their live or simulated weapon systems conducted their operations using shared tactical data from the Link-16 network and had at their

disposal voice loops to communicate to higher echelon, and voice over IP broadcast loops for early warning, engagement announcements and Link-16 network management. The Joint Analysis Team (JAT) members observed all operations and debriefed findings on a daily basis to all participants in order to incorporate lessons learnt as soon as possible.

TNO's responsibility during the execution phase was to have all J-ROADS weapon system simulations available for operational use and assist the warfighter in the use of J-ROADS. This included an initial J-ROADS familiarisation training and technical support with the daily simulation operations. The correct requested configuration of each simulated weapon system was prepared before each eight hour scenario started. During operations TNO SMEs provided over the shoulder support to the operators reacting to any question or problem concerning the J-ROADS simulations. For after action review purposes data was provided on operator actions and weapon system performance during the scenarios. Figures 10 and 11 show operators of the Royal NL Army and Navy operating their J-ROADS simulated FGBADS OC and ADCF.

Two blocks of scenario days were separated by three days of special experiments. JPOW itself is a test bed for new concepts, but the timeframe for when the simulated operations take place is strictly set. The special experimentation days did not have that restriction and also allowed very dedicated experiments by certain participants in separate time slots.



Figure 10: Royal NL Army officers operating the J-ROADS FGBADS OC simulation



Figure 11: Royal NL Navy officers operating the J-ROADS ADCF simulation

The Royal NL Army conducted operator procedure experiments during the dedicated experimentation period in JPOW IX. The experiments focussed on operator procedures in disrupted voice and data communication situations. Participating in the experiments were on the operational side the RNLAFF Deployable CRC, the FGBADS OC and the FGBADS SFC, and on the technical side TNO and the JPOW White Cell to orchestrate the scenario events. With especially designed scenarios, various voice only, data only, no communications or one-way communications situations were played. What type of communications failure occurred or when it occurred was unknown to the operators. Observers were monitoring all operator actions and reactions to assess the effectiveness of the emergency procedures and if the information presented to the operators was sufficient to successfully continue their mission.

4.5 Lessons learned

With applying the, for JPOW IX, newly developed and expanded modules of J-ROADS in a very realistic environment as JPOW is, we validated many of the modules. We also learned many lessons during the integration process and the exercise execution. Important are the improvements and expansions that were made in the J-ROADS Link-16 module, based on the interactions with live systems and valuable information received from discussions with the Joint Interface Control Officer (JICO) of JPOW IX. Very helpful in creating situational awareness and communicating concepts was the J-ROADS 3D display of the entire JPOW virtual battlefield.

The successful application of the FGBADS simulation by using multiple J-ROADS simulations in a distributed fashion to represent one system is a major lesson learned. Also in combination with the effective experimentation that was conducted with the system during the dedicated experimentation period of JPOW IX.

The M&S requirements for attending JPOW are increasing with every exercise. Features that were tested in one exercise become a requirement in the next, which is a form of CD&E by itself. The whole integration and execution process at JPOW is an important learning experience, providing the basis for further developments and better support to the Netherlands armed forces.

5.0 CONCLUSION

The modular set-up of J-ROADS and its application for analysis, exercise support and test bed with interchangeable modules of different fidelity levels has proven to be a successful concept. J-ROADS has contributed significantly to CD&E especially during military exercises. It has enabled TNO to effectively support the Netherlands armed forces during JPOW IX with operator-in-the-loop simulations of existing and future weapon systems, allowing training and experimentation in realistic and complex environments with simulated and live systems. Experimentation was performed with various configurations and added capabilities of weapon systems to assess the operational added value and validate TTPs. Very useful results were obtained and new insights were developed by all participants contributing directly to operational concepts, materiel acquisition processes and the further development of J-ROADS.

REFERENCES

- [1]. *The Seven Features of NLD NEC Transformation*, presentation by RDML Matthieu Borsboom, Chairman NLD NEC Board, Defence Staff, The Netherlands
- [2]. JPOW – Joint Project Optic Windmill, www.jpow.nl

ACRONYMS

ABL	Airborne Laser
ACCS	Air Command and Control System
ADCF	Air Defence and Command Frigate
AFB	Air Force Base
ATO	Air Tasking Order
AWACS	Airborne Warning And Control System
BMD	Ballistic Missile Defence
C2BMC	Command & Control, Battle Management and Communications
CD&E	Concept Development & Experimentation
CMO	Coverage Mission Order
CONOPS	Concept of Operations
CPX	Command Post Exercise
CRC	Control and Reporting Centre
DIS	Distributed Interactive Simulation
ECS	Engagement Control Station
FGBADS	Future Ground Based Air Defence System
HAPPIE	Hazard Area Prediction by Perturbations In Ensembles
HLA	High Level Architecture
ICC	Information and Coordination Central
INDIA	Intercepts Diagram model
IP	Internet Protocol
JAT	Joint Analysis Team
JICO	Joint Interface Control Officer
J-ROADS	Joint Research On Air Defence Simulation
JPOW	Joint Project Optic Windmill
LAP	Local Air Picture
M&S	Modelling & Simulation
MDA	Missile Defense Agency
NEC	Network Enabled Capability
NL	Netherlands
OC	Operating Centre
OPFOR	Opposing Force
PAC-3	Patriot Advanced Capability phase 3
RAP	Recognised Air Picture
RF	Russian Federation
RNLAF	Royal Netherlands Air Force
RNLN	Royal Netherlands Navy
RNLA	Royal Netherlands Army
SAM	Surface-to-Air Missile
SAMOC	SAM Operations Centre
SEAROADS	Simulation Evaluation Analysis and Research On Air Defence Systems
SENECA	Simulation Environment for NEC Assessment

SFC	SHORAD Fire Control
(V)SHORAD	(Very) Short Range Air Defence
SME	Subject Matter Expert
SOP	Standard Operating Procedure
TAOC	Tactical Air Operations Centre
TDL	Tactical Data Link
THAAD	Theatre High Altitude Area Defense
TMD	Theatre Missile Defence
TNO	Netherlands Organisation for Applied Scientific Research
TNO-ACE	TNO Advanced CD&E Environment
TTP	Tactics, Techniques and Procedures
UAV	Unmanned Aerial Vehicle

J-ROADS simulation support during the JPOW IX missile defence exercise

NATO MSG-045 Conference 5-6 October 2006, Rome

TNO | Kennis voor zaken



Wouter van der Wiel



TNO Defence, Security and Safety

- is a *strategic partner* of the Ministry of Defence
- makes *innovative contributions* to enhancing the security of The Netherlands both at home and abroad
- uses *accumulated knowledge* for foreign governments and for (defence-related) industries in The Netherlands and abroad



Training and exercise support

- Development of innovative training concepts and methods
- Development of simulation tools for training and exercise support
- On-site support of military exercises



J-ROADS introduction



J-ROADS - Joint Research On Air Defence Simulation

TNO developed interactive simulation environment on extended air defence to support national and international armed forces with:

1. Analysis of System and Architecture Performance
2. Exercise Support & Training
3. Test Bedding

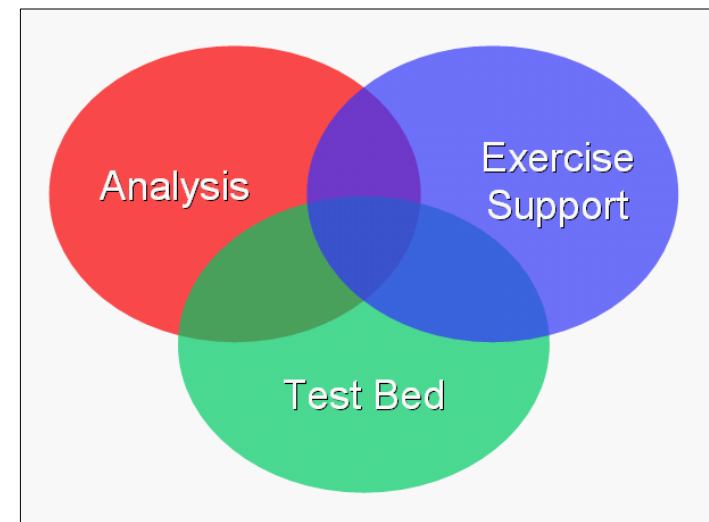

From SEAROADS to J-ROADS

1989 SEAROADS I

- Process oriented model
- Air defence analysis in naval environment

1998 SEAROADS II

- Transformation to object oriented model (4 years)
- Air defence analysis in naval environment

2003 J-ROADS

- Joint funding from Royal NL Air Force, Army and Navy
- New interactive interfaces for exercise support
- DIS, HLA and Link-16 capable
- Extended air defence analysis in naval, air, land and space environment

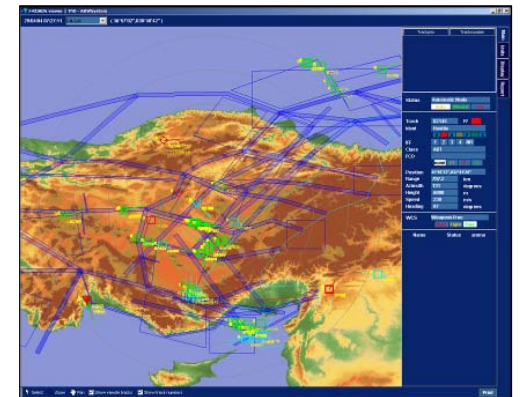
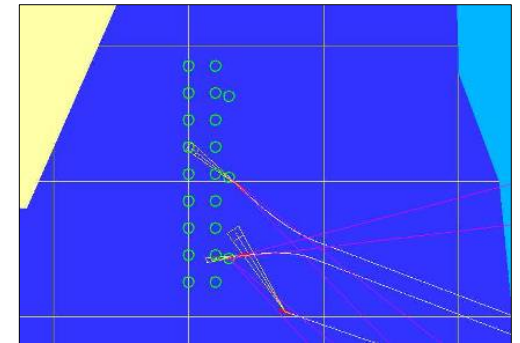

J-ROADS modular set up - System

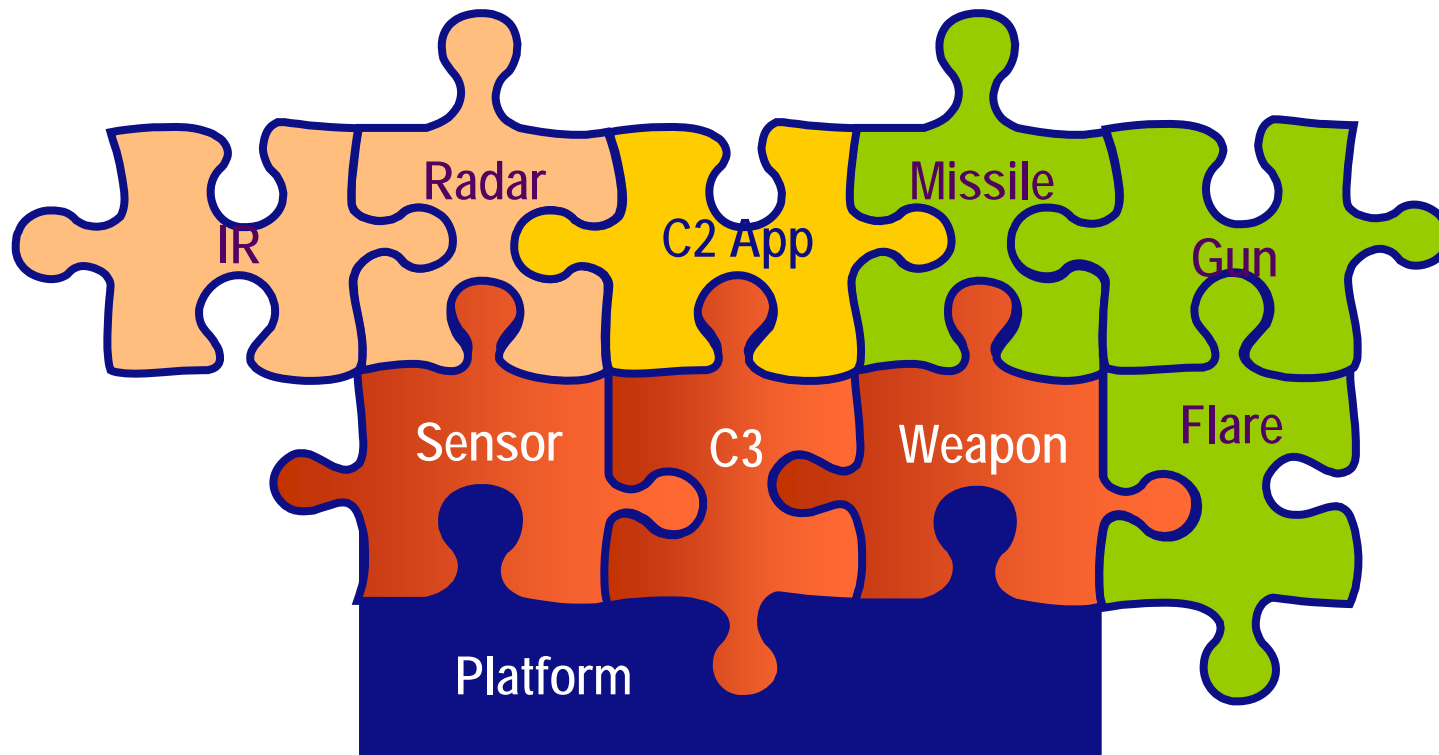

J-ROADS modular set up - Architecture

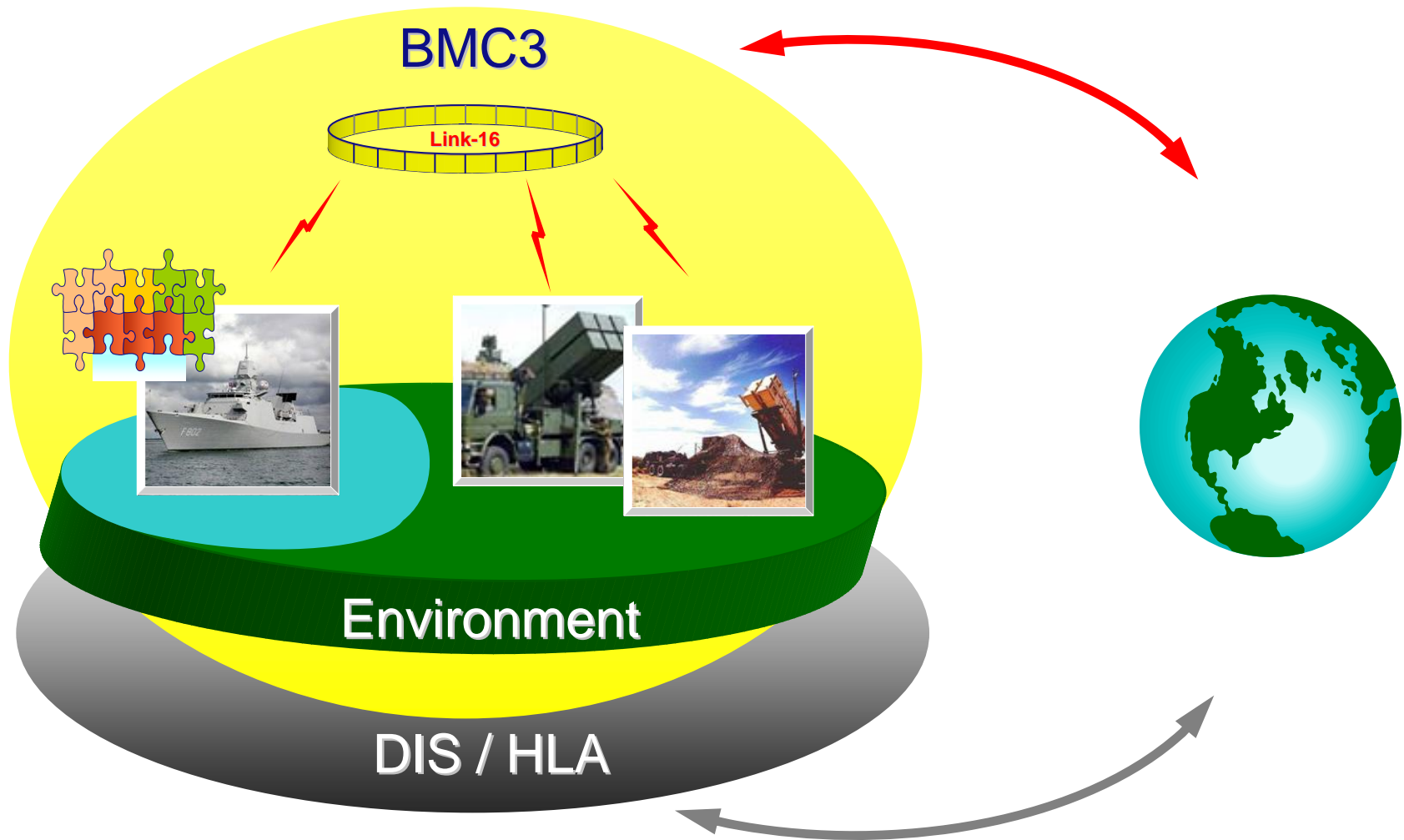

J-ROADS real-time 3D visualisation

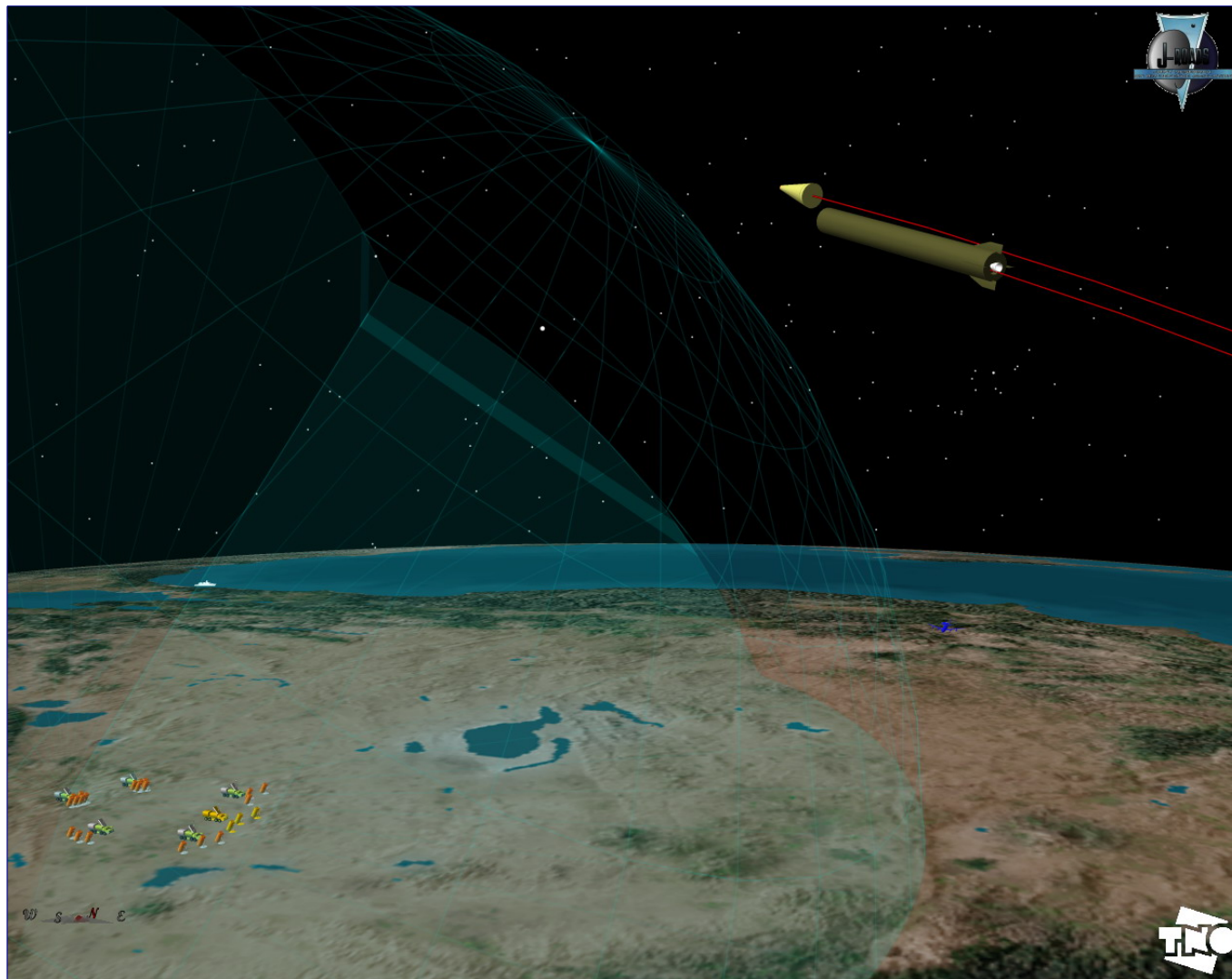

J-ROADS exercise support

- Fully interactive simulations of entire weapon systems
- Connections to simulators and live weapon systems
- Data recording and visualisation for after action reviews
- Team of TNO experts to set up simulations and tactical data link networks, and provide assistance

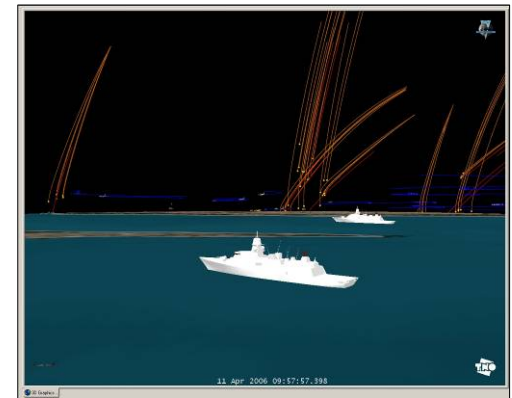

NATO – Russian Federation CPX

- NATO – Russia Council (established in 2002)
- CPX #2 hosted by RNLAf, GGW De Peel, March 2005
 - Support TMD interoperability project
 - Support NATO - RF CONOPS development
 - Support NATO - RF SOP development
- J-ROADS managed entire simulation network

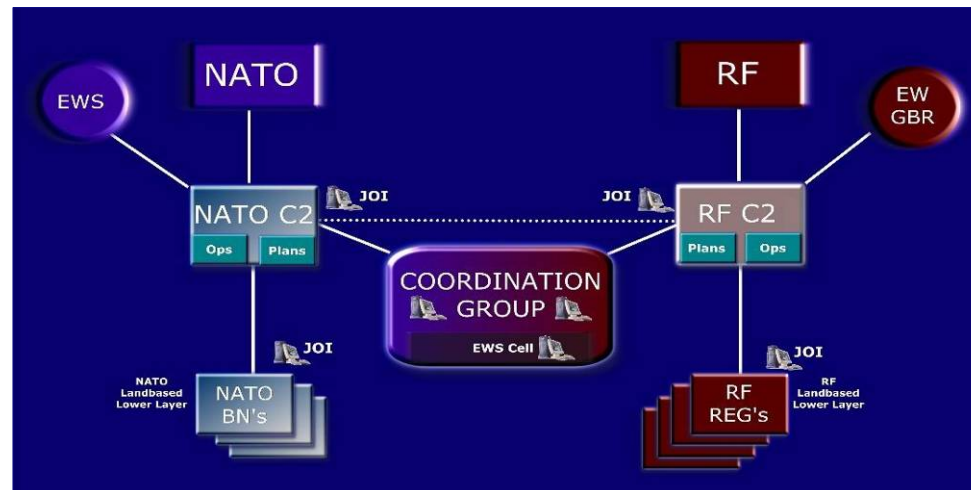
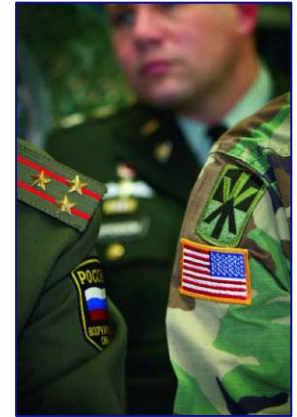

TNO support at NATO-RF CPX (2005)

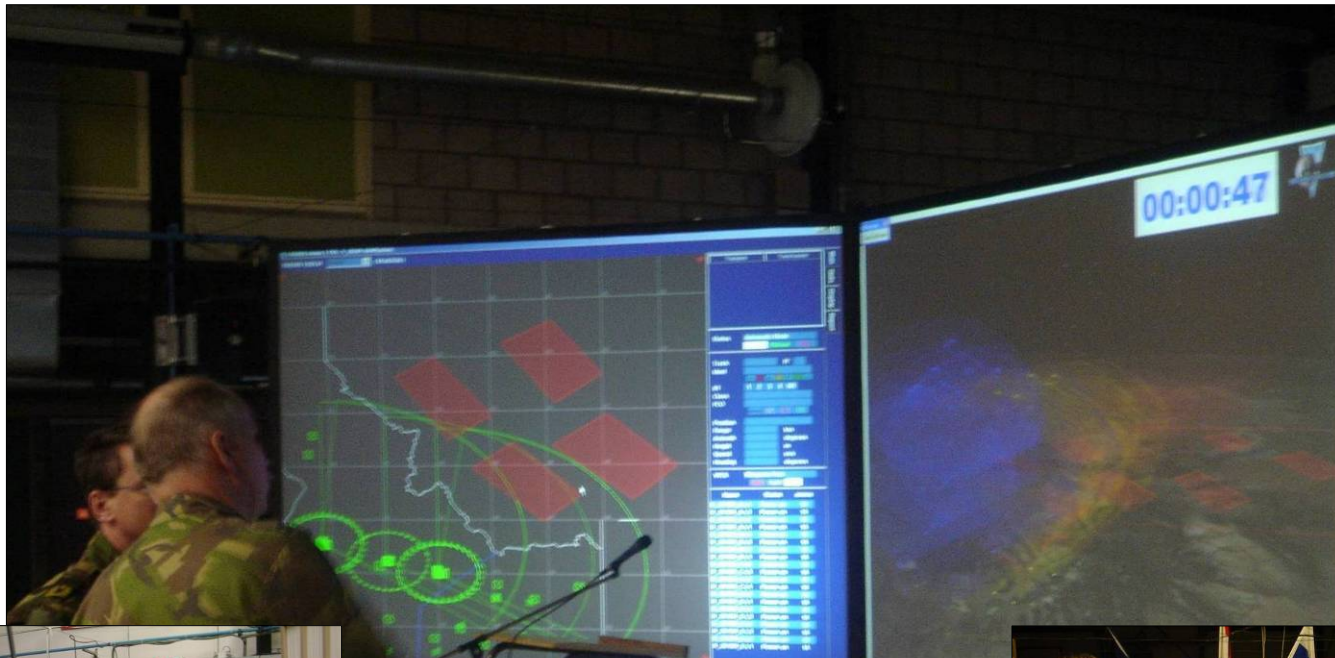



SENECA

- Simulation Environment for NEC Assessment
- Based on “*Netwerkend Optreden*” NEC policy study NL Armed Forces
- Spiral development of NEC concepts and transformation of NL Armed Forces to achieve enhanced mission execution
 - Improved effectiveness
 - Improved efficiency
 - Execute new missions
- Aims for SENECA Phase 1
 - Initiate first NL Joint NEC experiment
 - Develop NL distributed joint experiment environment
 - Combine existing operational capabilities with simulated capabilities
- J-ROADS provided joint COP for SENECA Phase 1

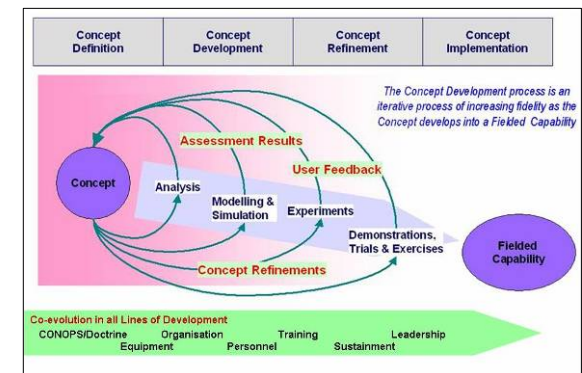

SENECA Phase 1 (2005)

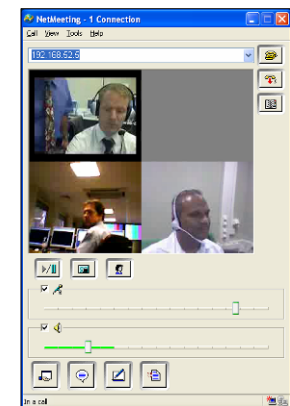
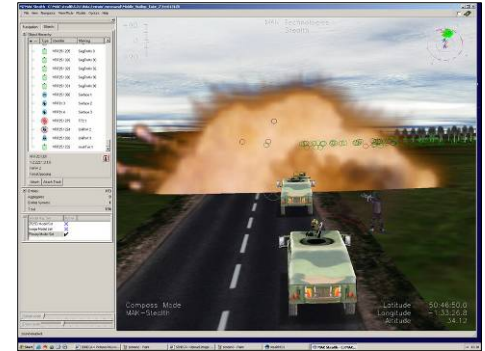
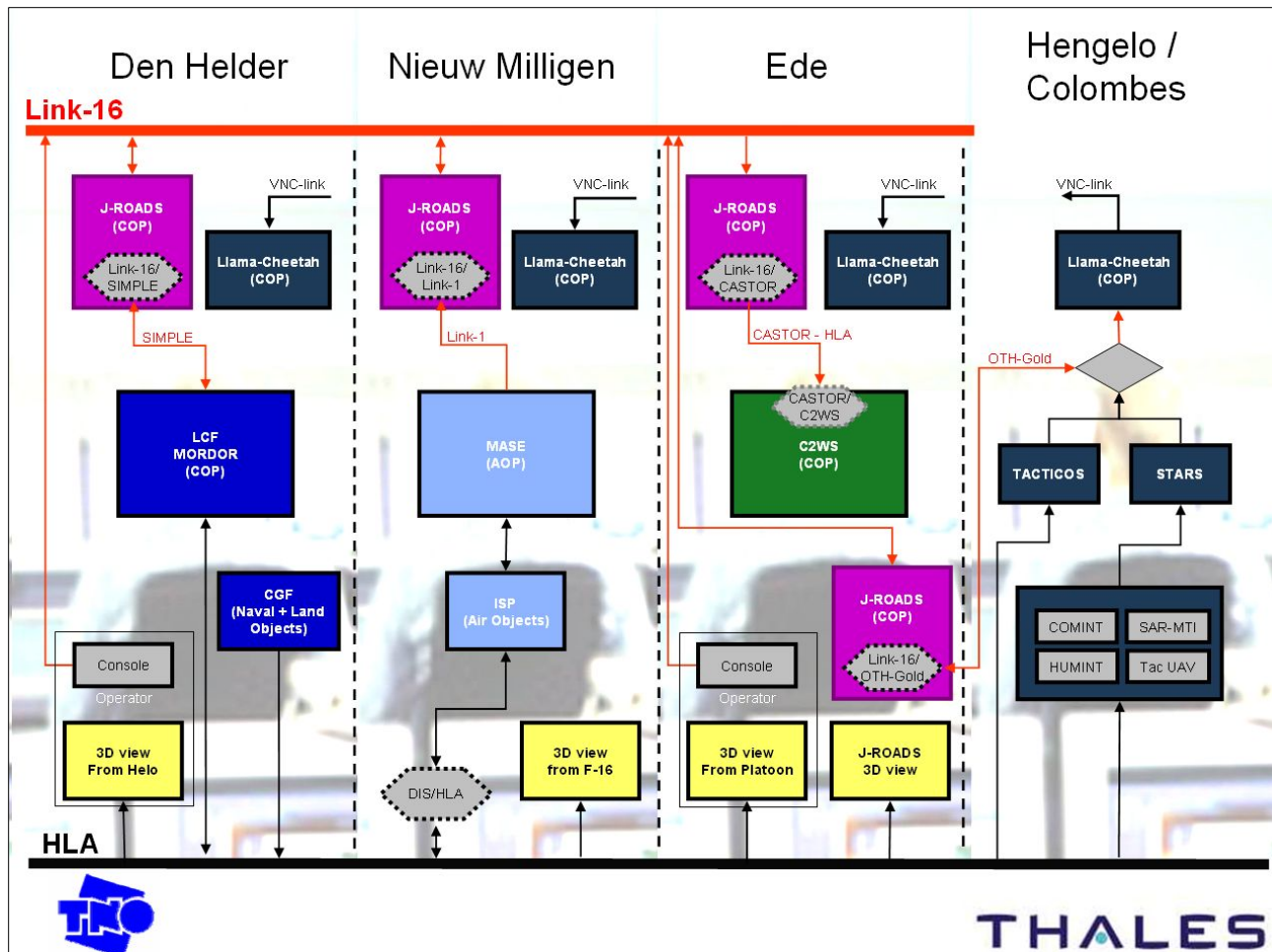

Joint Project Optic Windmill (JPOW)













- JPOW is a test bed for new air defence concepts, doctrines, TTPs and actual air defence systems
- Aim is to unite the US, NL and GE efforts on air and missile defence, with emphasis on mission planning and execution on all levels of command and control
- JPOW evolved into the leading European Theatre Air and Missile Defence exercise, organised by the Royal NL Air Force with support of USEUCOM, the GAF and the US Missile Defence Agency (MDA)
- JPOW IX: March – April 2006, Crete, Greece
 - 3 weeks integration and testing
 - 3 weeks exercise and experimentation

JPOW exercise concept



- Combination of live and simulated weapon and C2 systems
 - Live
 - “Train as you fight”
 - Serious exercise, no game
 - Training on the job
 - Simulated
 - Enabler to build war-like environment
 - Enabler to incorporate new technologies before procurement
 - Easy to train in joint/combined environment
 - Easy to try out new tactics and procedures
 - Low cost solution
- Joint Analysis Team
- Joint Experimentation Team
- Daily player debriefs

JPOW IX participants

<p>RNL-Air Force RNLAF Missile Group 1 BM/C4I Entity (ICC/TCS) 3 Patriot FU's 3 NL FMS-D's Contribution Virtual Patriot units (JROADS) BCP/TACO JOI-2 AOCS NM Deployable CRC (ASE)</p> <p>RNL-Navy 2 ADCF Simulations (JROADS)</p> <p>RNL-Army FGBAD (Future GBAD) Simulations (JROADS)</p> <p>Joint NDMC</p>	 	<p>HE Air Force 350 GMW 1 FDC Entity (ICC) 1 Patriot FU FMS-D's provided by MDA Exercise Facilities NAMFI & Souda Airbase</p> 
<p>GE - Air Force SAM WING 1 BM/C4I Entity (I-SAMOC) 1 FDC Entity (ICC) 3 Patriot FU's 3 FMS-D's provided by MDA Contribution Virtual Patriot units (JROADS) Deployable CRC (ARKONA) Deployable CRC (GIADS) (Experiments Only) ADIVS Data Link Management Cell HEAT</p> <p>GE - Navy 2 F124 AD Frigate Simulations (ELVIS)</p> <p>GE - Army BDE Level AOAD</p>	 	<p>United States Armed Forces</p> <p>US Army 263th AAMDC US Army 11 ADA BDE (Personnel) US Army 69 ADA BDE 1 BM/C4I Entity 1 FDC Entity 2 Patriot FU's Incl 2 FMS-D (to be provided by MDA) US-Army MSIC US-Army AMDBL USASMDC USASMDC/ARSTRAT JTAGS US Army PEO-Msl & Space/MDA JRE US Army PEO Msl & Space TSCC US Army PEO Msl & Space JICO Tools MDA CAMDEN MDA MDST MDA C2BMC MDA PEGEM MDA ABL (Sim) MDA THAAD (Sim) MDA GMD (Sim) MDA AEGIS BMD (Sim) DISA GCCS</p> 
<p>NATO SHAPE NACMA - ACCS Prototype Components BICES NC3A - PLATO NC3A - LSID CC AIR IZMIR (TU) CC AIR RAMSTEIN (GE) CAOC 2 CAOC-5 CAOC 7 CAOC 9</p> 		<p>Royal Norwegian Air Force NASAMS 2</p>  <p>EADTF EAD-Cell</p>  <p>1st GE - NL ARMY CORPS 1st GE - NL ARMY CORPS AOCC</p> 

JPOW IX defence organisation

- Joint and Combined Task Force (JCTF)
- 48 hour planning cycle
- TAOC defines
 - prioritised asset list (CMO)
 - attack ops (ATO/ACO)
- Air defence units
 - make defence design in co-ordination with neighbouring units
 - execute defence design

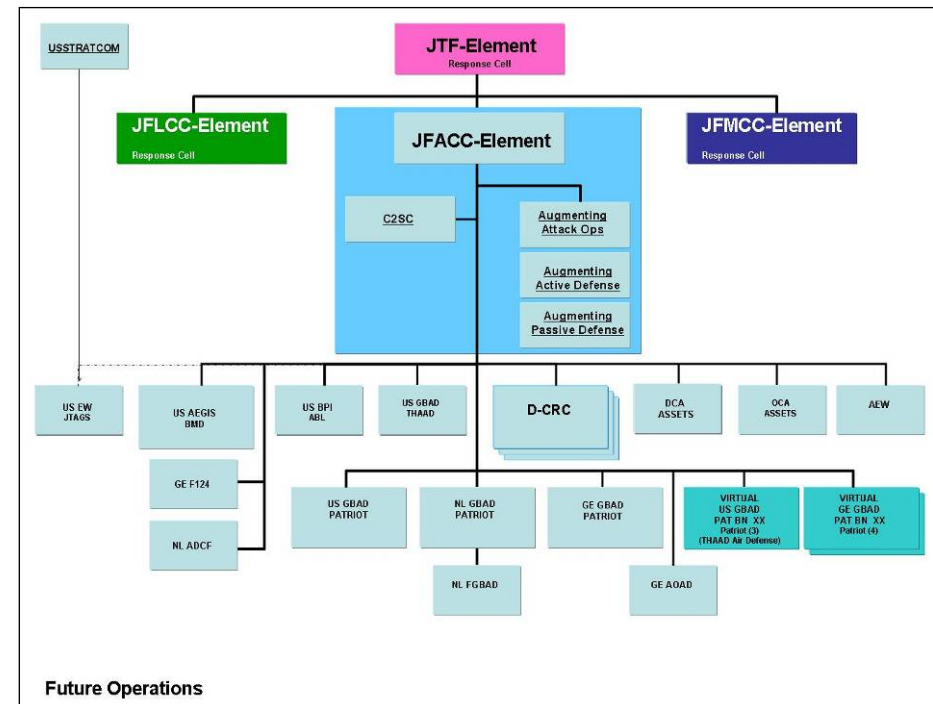

NATO Missile Firing Installation

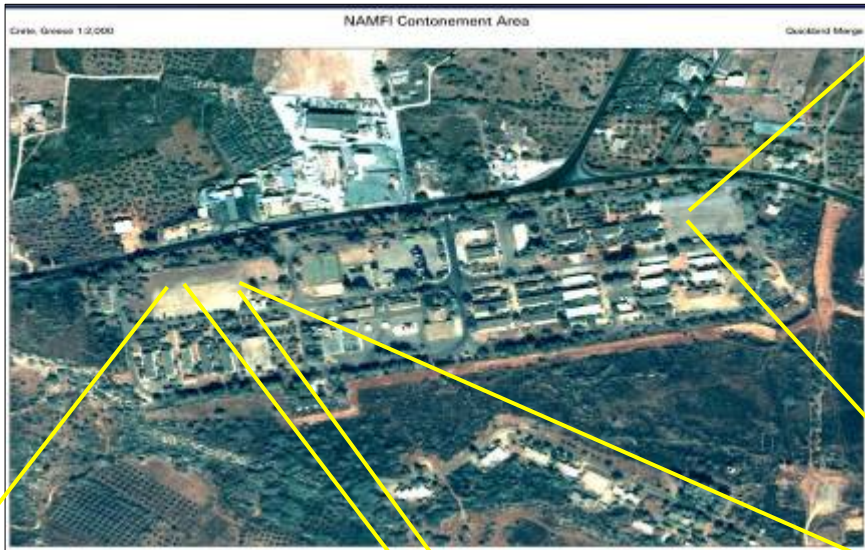

Naval Support Activity Souda



JPOW IX Link-16 network

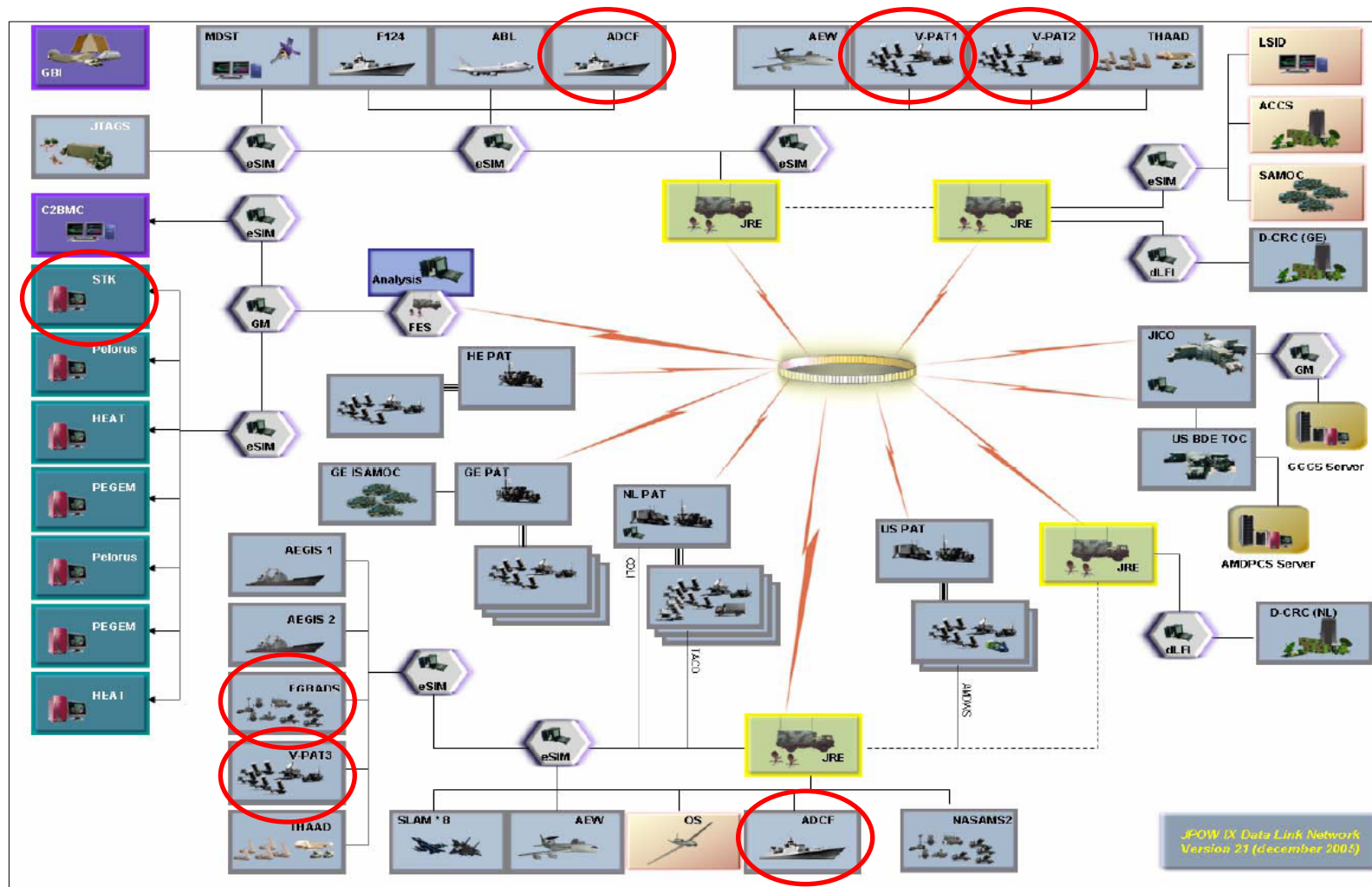

Link-16 accreditation

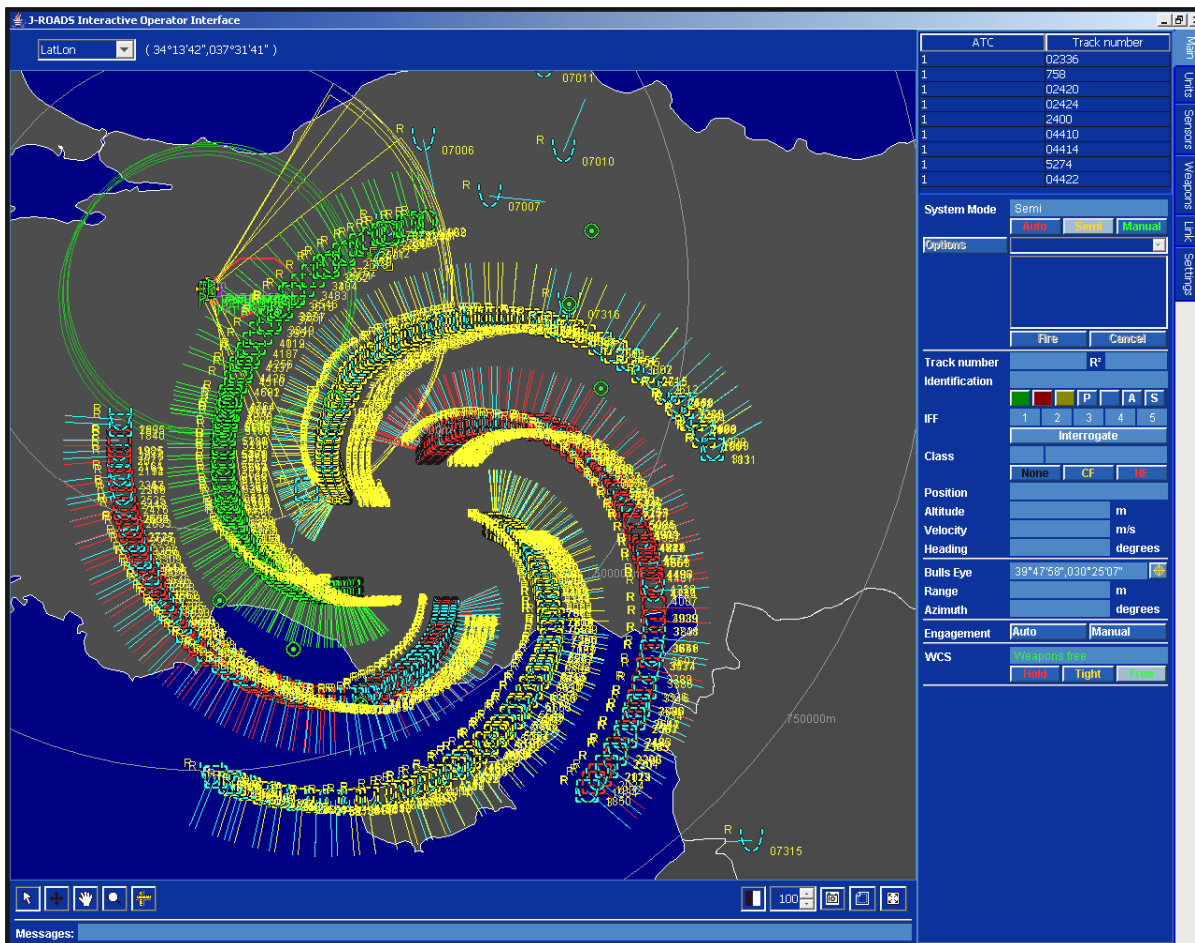

- STANAG implementation
- Flexibility and robustness
- SMEs on-site

TNO support at JPOW IX

- Provide detailed interactive simulations of NL missile defence systems for training and concept development & experimentation
- Royal NL Air Force PATRIOT battalions
- Royal NL Navy ADCFs
- Royal NL Army FGBADS
- Opposing Force air defence regiments
- TNO team: 6 – 10 SMEs for 6 weeks





Royal NL Army FGBADS

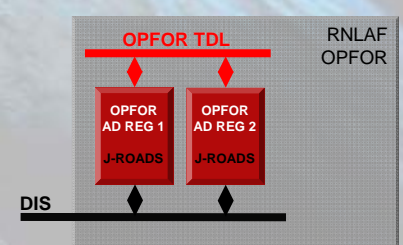
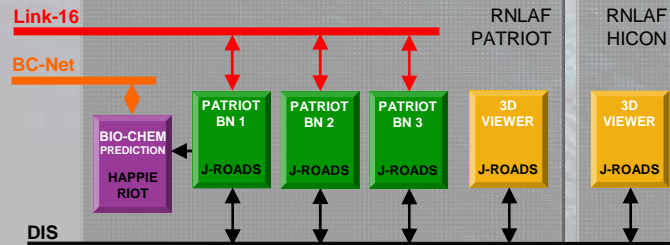
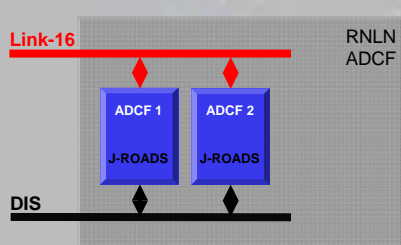
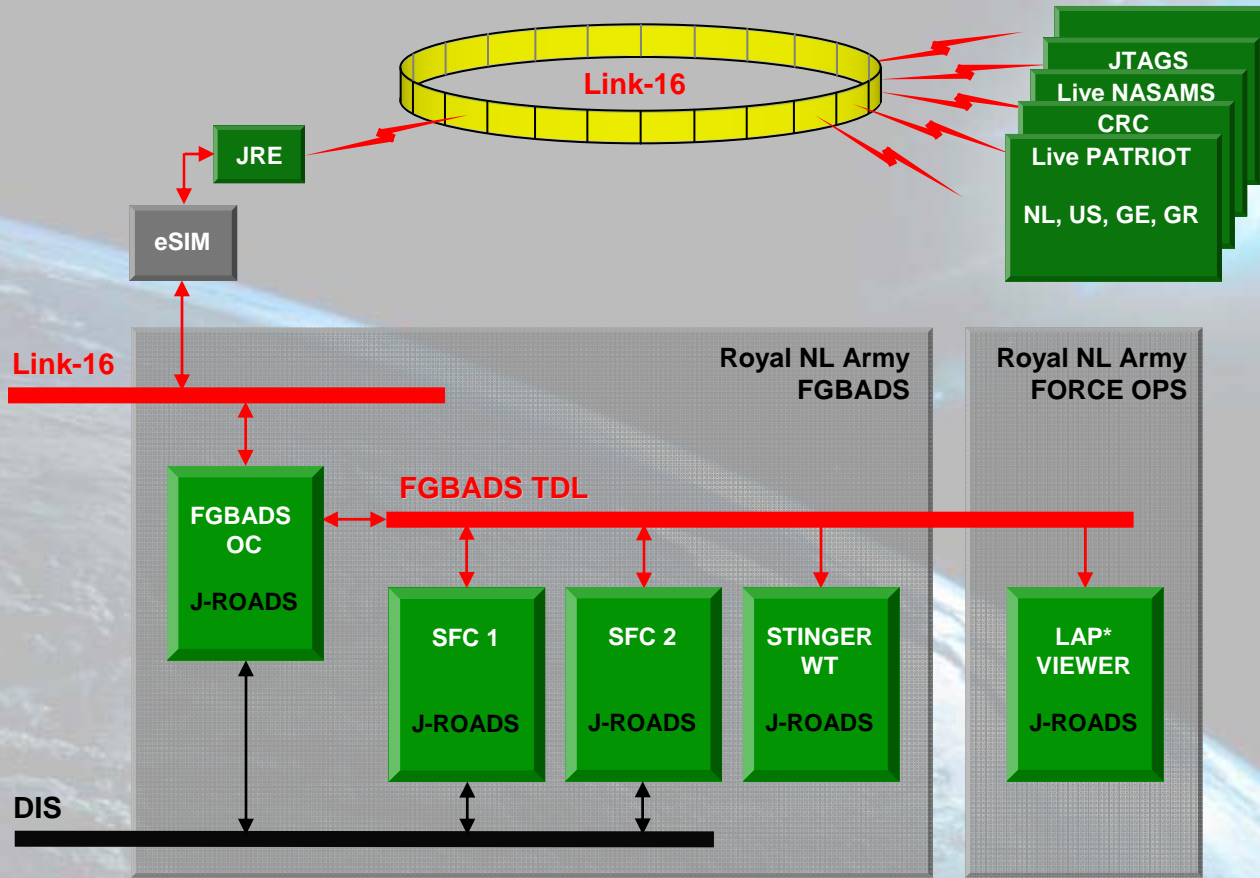

Royal NL Navy ADCF in Souda Bay

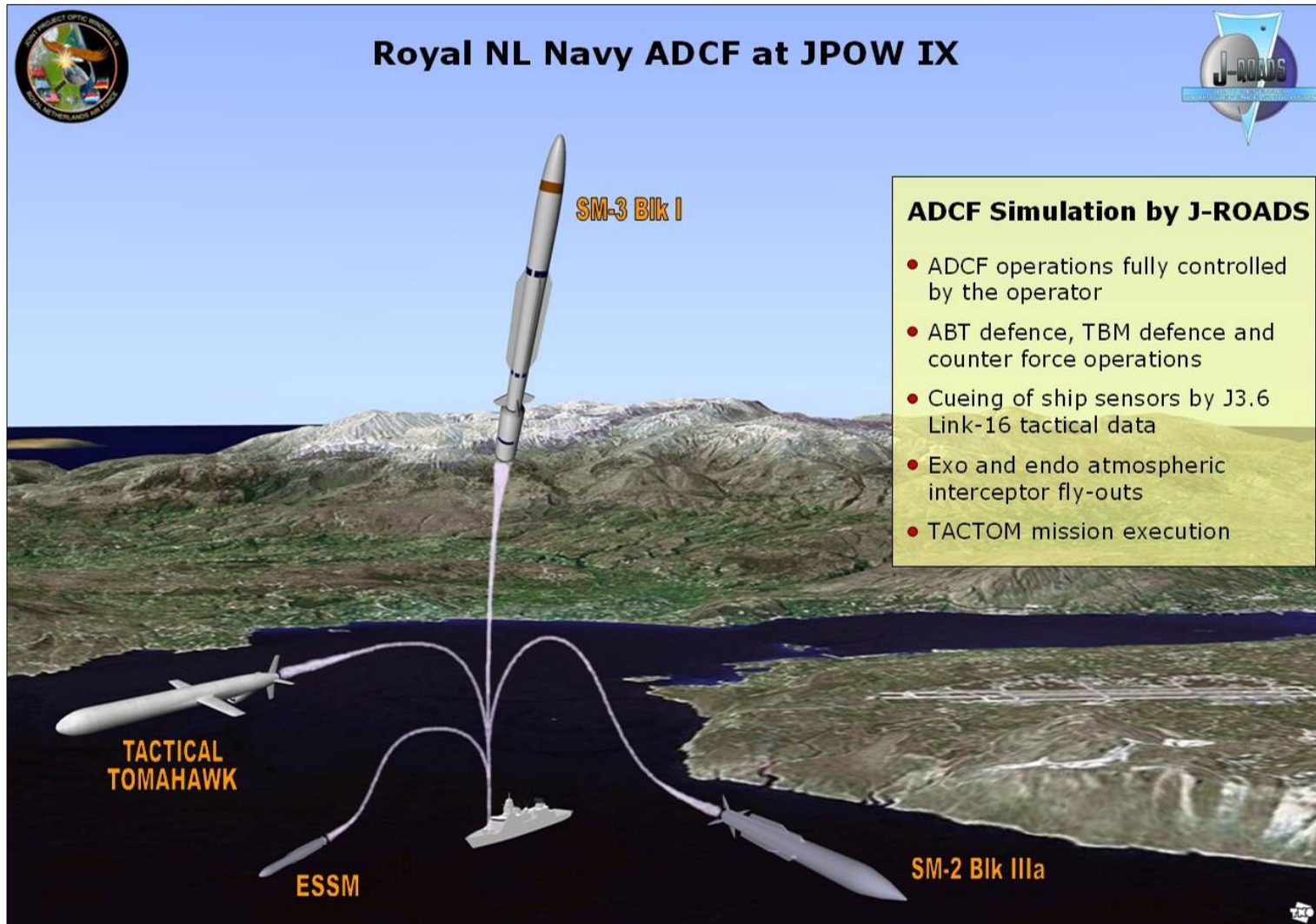

JPOW IX scenario example

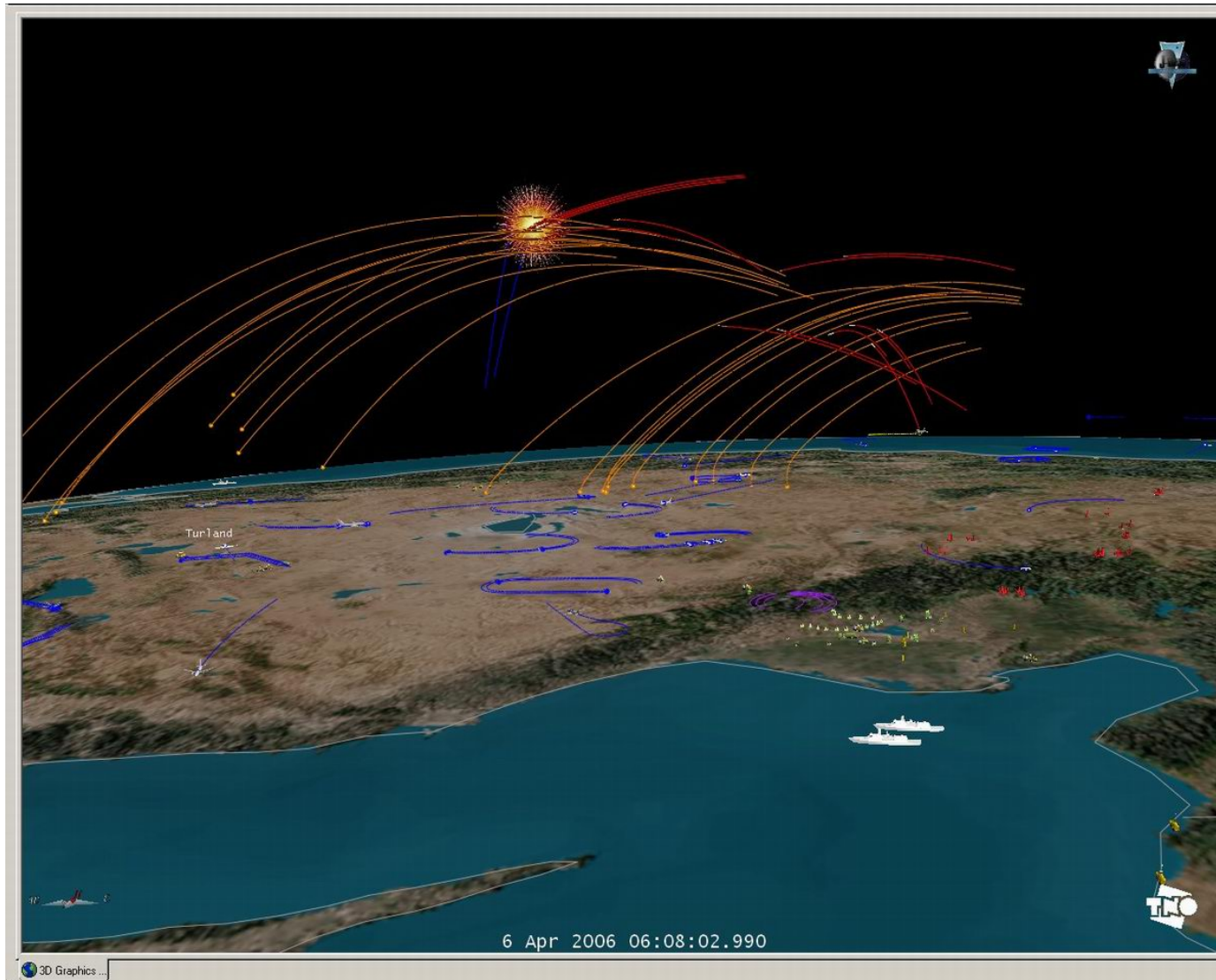

Live Firing

- PATRIOT live firing of four PAC-2 interceptors



JPOW results and lessons learned

- Application of Global Command and Control System (GCCS) proved valuable
- NATO ACCS functions demonstrated successfully
- Link-16 network proved capable, but major challenge to operate

- RNLA FGBADS and RNLAF CRC experiments with tactical data link deconfliction and engagements
- RNLN experimentation with TACTOM and SM-3
- RNLAF live and simulated operations in joint and combined environment

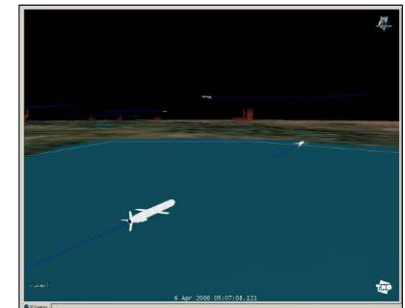

J-ROADS simulation support during JPOW IX

- Modular set-up of J-ROADS
- Robust tactical data link modelling
- Connections to live systems
- Realistic environment for training and CD&E
- On-site support with SMEs

