

NSWC/DL TECHNICAL LIBRARY
2000347553

963768

NAUSWC-MP-91-032

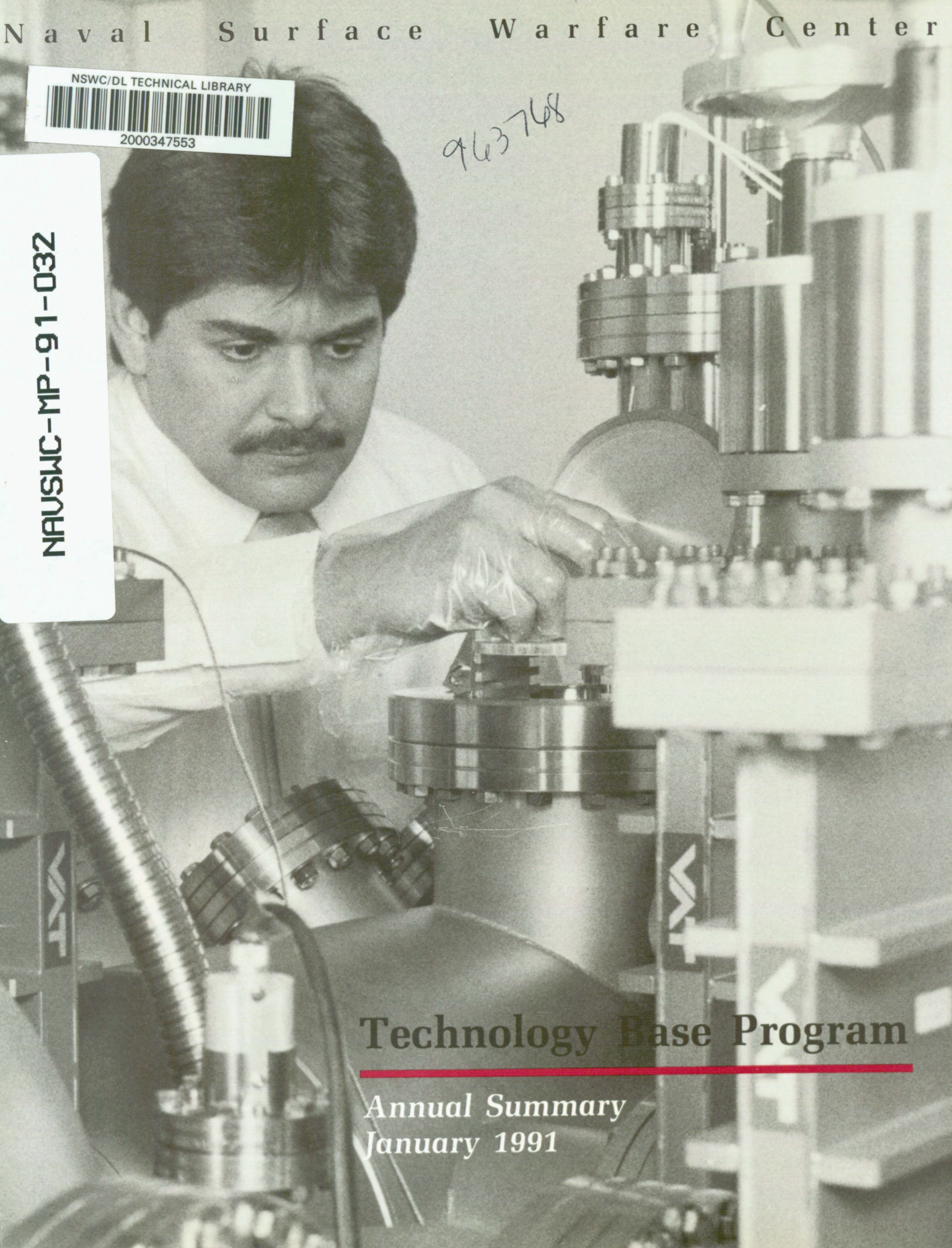

Technology Base Program

Annual Summary
January 1991

Report Documentation Page

*Form Approved
OMB No. 0704-0188*

Public reporting burden for the collection of information is estimated to average 1 hour per response, including the time for reviewing instructions, searching existing data sources, gathering and maintaining the data needed, and completing and reviewing the collection of information. Send comments regarding this burden estimate or any other aspect of this collection of information, including suggestions for reducing this burden, to Washington Headquarters Services, Directorate for Information Operations and Reports, 1215 Jefferson Davis Highway, Suite 1204, Arlington VA 22202-4302. Respondents should be aware that notwithstanding any other provision of law, no person shall be subject to a penalty for failing to comply with a collection of information if it does not display a currently valid OMB control number.

1. REPORT DATE 1991	2. REPORT TYPE	3. DATES COVERED 00-00-1991 to 00-00-1991			
4. TITLE AND SUBTITLE Technology Base Program		5a. CONTRACT NUMBER			
		5b. GRANT NUMBER			
		5c. PROGRAM ELEMENT NUMBER			
6. AUTHOR(S)		5d. PROJECT NUMBER			
		5e. TASK NUMBER			
		5f. WORK UNIT NUMBER			
7. PERFORMING ORGANIZATION NAME(S) AND ADDRESS(ES) Naval Surface Warfare Center, Dahlgren, VA, 22448-5000		8. PERFORMING ORGANIZATION REPORT NUMBER			
9. SPONSORING/MONITORING AGENCY NAME(S) AND ADDRESS(ES)		10. SPONSOR/MONITOR'S ACRONYM(S)			
		11. SPONSOR/MONITOR'S REPORT NUMBER(S)			
12. DISTRIBUTION/AVAILABILITY STATEMENT Approved for public release; distribution unlimited					
13. SUPPLEMENTARY NOTES					
14. ABSTRACT					
15. SUBJECT TERMS					
16. SECURITY CLASSIFICATION OF:			17. LIMITATION OF ABSTRACT Same as Report (SAR)	18. NUMBER OF PAGES 20	19a. NAME OF RESPONSIBLE PERSON
a. REPORT unclassified	b. ABSTRACT unclassified	c. THIS PAGE unclassified			

Strifors, H., and Gaunaud, G., "Wave Media," *Journal of the Acoustical &*

Gaunaud, G., "Distortions in the Bac Elastic Shell Due to its Proximity t the Second IMACS Conference on C 410-446, North Holland, Amsterda

Gaunaud, G., and Werby, M., "Flexu Solid Elastic Spheroids," *Procedir Butterworth Scientific Ltd, 1989.*

Simons, D. G., Price, J. L., Land, D. J. Sections for Targets from $Z = 21$ to Energy Range 0.2-2.5 MeV/u," *Phy*

Neifeld, R. A., Gunapala, S., Liang, G. D. G., and Hill W. T., III, "Systema Ablation of $\text{SmBa}_2\text{Cu}_3\text{O}_7$," *Applie*

Land, D. J., "Application of a Time-De lations of K-Shell Ionization," *Nuc* 442, 1989.

Carter, P., Cawley, R., and Mauldin, F for Graphs of Functions," in *Fracta* A. Weitz, L. M. Sander, and B. B. M Proceedings, Fall meeting, 1988.

Uhm, H., Namkunk, Wl, Choe, J. Y., & High Power Gyrotron," *Physical R*

Namkunk, W., Choe, J. Y., Uhm, H., & Fundamental and Harmonic Cycle *Science*, Vol. 16, p. 149, 1988.

Finn, John M., Hanson, James D., Kai Magnetic Dynamos Exist?" *Physic*

Hammel, Stephen, and Jones, Christo Dissipative Maps of the Plane," *Ph*

Savage, Howard T., and Adler, Charle Ferromagnets," *Materials Science*



The Naval Surface Warfare Center (NAVSWC) employs over 2000 engineers and scientists at the Dahlgren and White Oak sites. Many are engaged in what has become known as "tech base," that foundation of scientific and technological expertise upon which rests present credibility and future innovation . . .

NAVSWC MP 91-32

Approved for public release; distribution unlimited.

About the cover . . .

The Center has recently made a major investment in a Molecular Beam Epitaxy System. The system will be used to conduct research on semiconducting materials and on graded interfaces, as well as to develop prototype devices.

For further information, contact the Naval Surface Warfare Center, Technology Base Office, 10901 New Hampshire Avenue, Silver Spring, Maryland 20903-5000, telephone (301) 394-2427.

This Document Touches on Seven Key Elements of the NAVSWC Technology Base Program:

Technology Base Investment Strategy Update

Characteristics of the present tech base program and plans for the future

Technology Base Support of NAVSWC Product Lines

The tech base profile . . . distribution of in-house tech base effort among departments and among product lines

Technology Base Annual Cycle

The cycle of events that drives the tech base program

Accomplishment Highlights

Technical highlights and milestones or other significant accomplishments of the tech base program

Special Events

Facets of the program that reflect, promote, and feed a healthy technology base

Technology Base Transitions

Examples of various returns on our tech base investments

Publications, Patents and Licenses

Documentation of successful in-house, hands-on tech base efforts

1

Technology Base Investment Strategy Update



Characteristics

The Center maintains four necessary ingredients or characteristics in the Technology Base Program. The program must: 1) advance the state of the art in science and engineering, 2) be a window to the international technical world, 3) provide the expertise necessary for the Center to be a smart buyer, and 4) demonstrate new concepts for weapon systems and subsystems.

While none of these characteristics should ever become weak relative to the others, the Center is presently embarking on a plan to reemphasize items 1 and 4, leading to heightened activity in creative, in-house, hands-on work. The plan (documented in NSWC MP 89-415, "Plan of Action for NSWC Technology Base Growth," January 1990) is multi-faceted and will take four years to complete. Some of the specifics of the plan are outlined below.

Objective 1

The first objective is to increase the number of personnel working on technology base funded projects by one third over the next four years.

Several significant steps will have to be taken in order to achieve this very ambitious goal. The first step is to identify those NAVSWC product lines with inadequate technology base support, and to formulate the corresponding "requirements pull" type of technology base proposals.

Next, a more effective process to identify and pursue RDT&E Category 6.3a (Cat 6.3a) opportunities must be developed and implemented.

Lastly, biases will be applied to a number of our internally controlled resources to induce a corporate inclination toward technology base work.

Objective 2

Increase technology base work in support of and funded by NAVSWC programs.

In a Center such as NAVSWC, a large amount of development work is performed in direct support of, and needed specifically by, a large engineering program. In some cases, the new knowledge gained by this development work is genuinely generic, and represents not only a contribution to the specific program, but also a significant contribution to the fundamental state of understanding in the field.

This gray interface between technology base and non-technology base might be called “*de facto* tech base,” and is properly supported by either technology base or non-technology base funds. Departments will be asked to identify *de facto* tech base work, and encouraged to support the growth of such projects when it is clearly in the long- or short-term interest of the weapon system program to do so.

Objective 3

Reinforce the value of technology base work within the Center and recognize successful performance.

The value of technology base work will be reinforced if the results of the technology base work are used. Use will grow into need and need into stability. Effective “milking” of the technology base results can take place only through a communication network that links departments, sites, disciplines, corporate cultures, and hierarchical levels within the Center, and links the Center with program and platform sponsors at the Systems Commands (SYSCOMs) and the Office of the Chief of Naval Operations (OPNAV).

Enhanced lines of communication and interaction will take place through a variety of forums, news letters, NAVSWC reports, press releases, and outside publications. In addition, a vigorous program of temporary detail assignments and personal interactions, both inside and outside the Center, will be maintained.

The value of technology base work will also be recognized directly . . . through special awards, such as the Science and Technology Excellence Award, and through the existence of a clear-cut career path to senior technical positions via successful hands-on, in-house technology base work.

Technology Base Support of NAVSWC Product Lines

In-house, hands-on technology base support of Center product lines is an integral part of our basic function of developing new weapon systems for the fleet. Shown here is NAVSWC's tech base profile, based on a FY90 survey. The graphs represent total in-house tech base effort and show the distribution of that effort among the various technical departments and product lines.

The organization is structured so as to place the bulk of the technology base work in the Research and Technology Department. On the other hand, there is a somewhat classic distribution of effort among the key NAVSWC product lines.

Distribution Among Departments of In-House Tech Base Effort

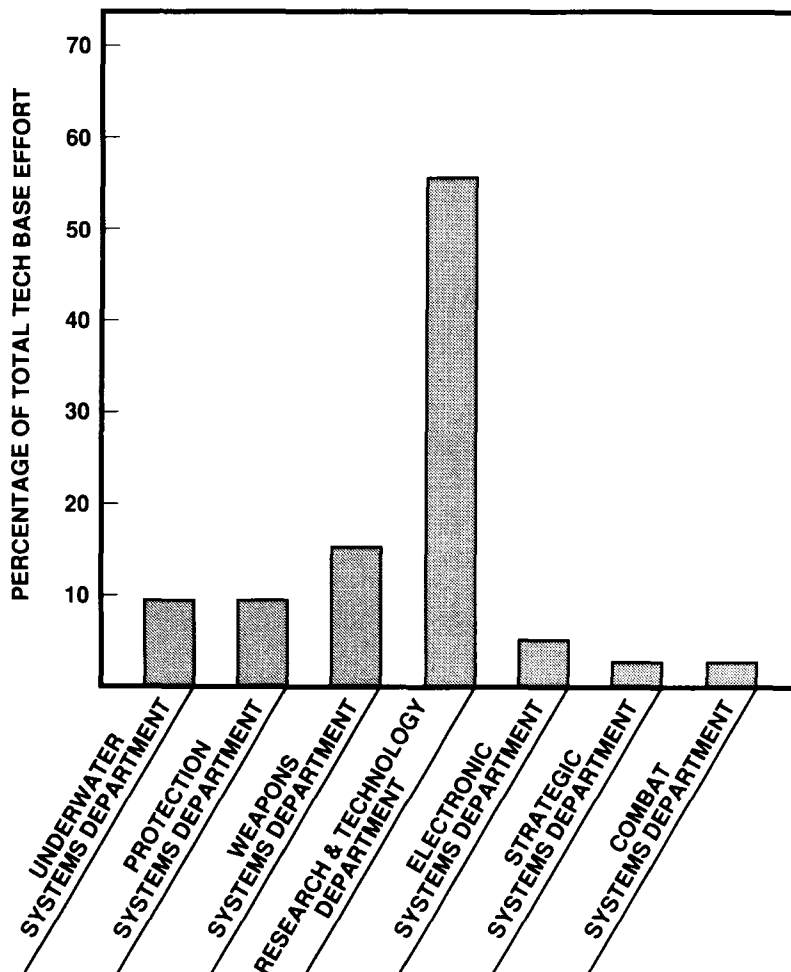

**Distribution Among Product Lines
of In-House Tech Base Effort**

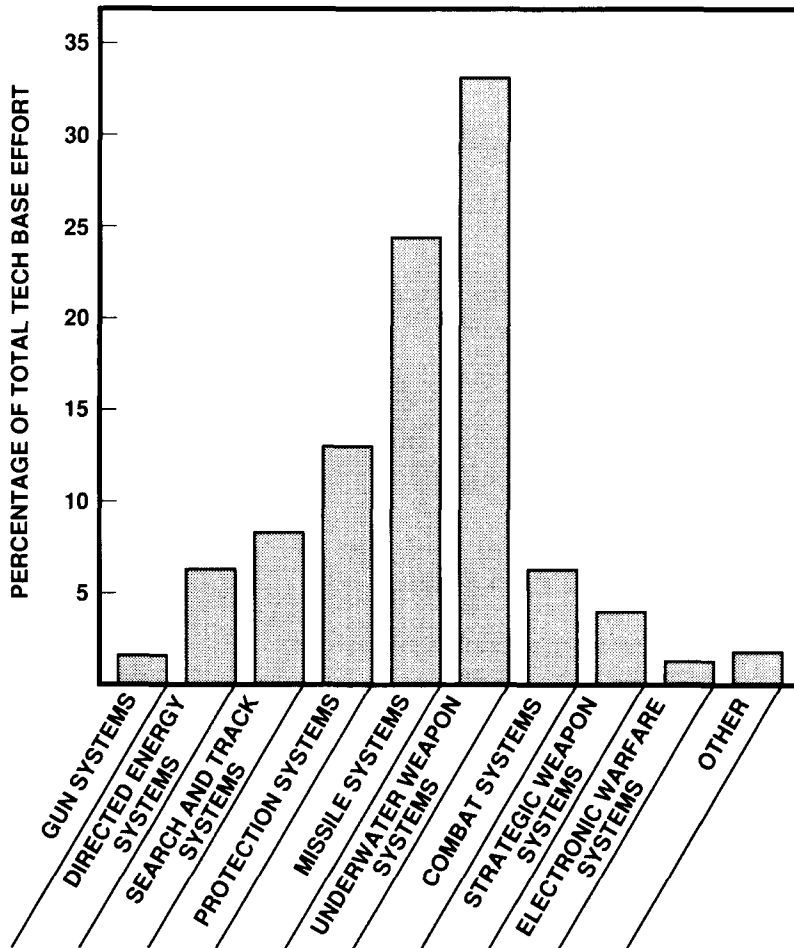

Technology Base Annual Cycle

Independent Research Program

Call for written proposals March
Reviews and proposal presentations June
Funds distributed October
Annual report to OCNR January

Independent Exploratory Development Program

Call for written proposals March
Reviews and proposal presentations July
Funds distributed October
Annual report to OCNR January
Mid-year reviews March

Focused Technology

Call for written proposals August
Reviews and proposal presentations September
Selections for focused attention announced October
Mid-year reviews March

ONT ASW Technology Blue Sky Proposals

Call for written proposals June/July
ONT screening September
Funds distributed December

ONT 6.2 Block Programs

Surface Launched Weaponry	Weapons Materials
CBR Defense	Marine Corps Weaponry
Explosives and Undersea Warheads	Mines
Engineering of Complex Systems	

Annual program plans submitted to ONT June
Program progress reviews October - December
Trimester reports February/June/October
Major accomplishments October

Advanced Technology Demonstrations

Balanced Technology Initiatives

Proposals submitted to the Tech Base Office March
Proposals forwarded to ONT, SYSCOMS, OPNAV April/May
Proposal screening/prioritization July

Tech Base Office

IR/IED Navy-wide R&D review June
Science and Technology Excellence Award December
Technology to Sea Award December

The cycle of events that drives the tech base program

IR and IED Awards December
Summer professor selections January
Post-Doctoral Fellow selections (quarterly)
Biannual Technology Transfer Meeting May/November

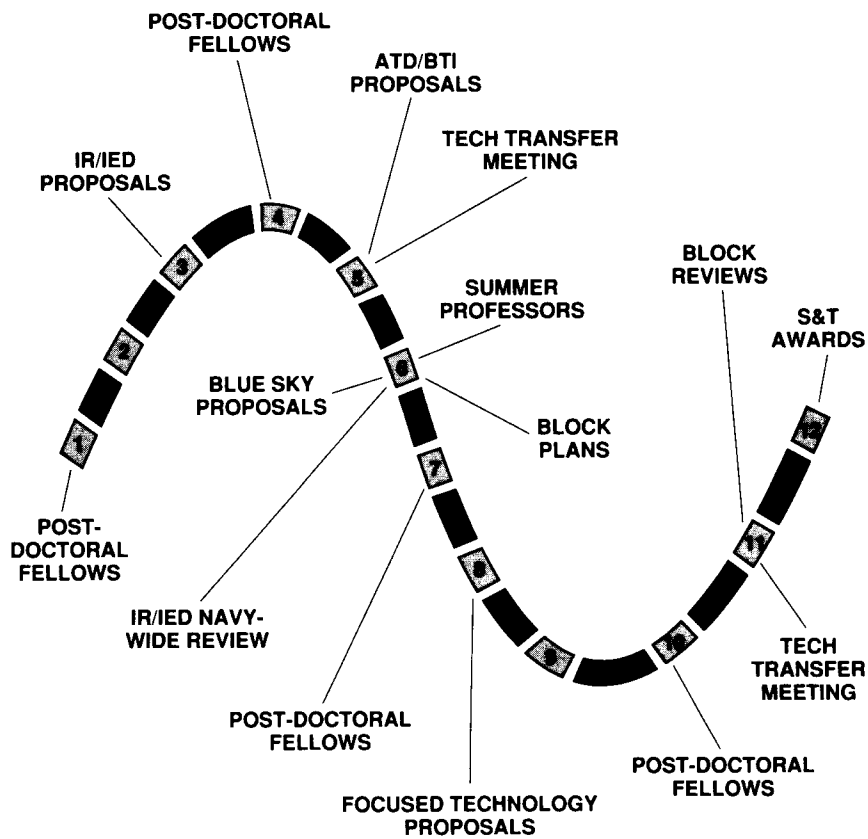

4

Accomplishment Highlights

Independent Research . . . CUSPTRON

CUSPTRON is a high power, high frequency microwave source. This low noise, spectrally pure source is still in the conceptual phase, but laboratory hardware has produced 10 kW at 6 GHz, with a corresponding efficiency of 10 percent.

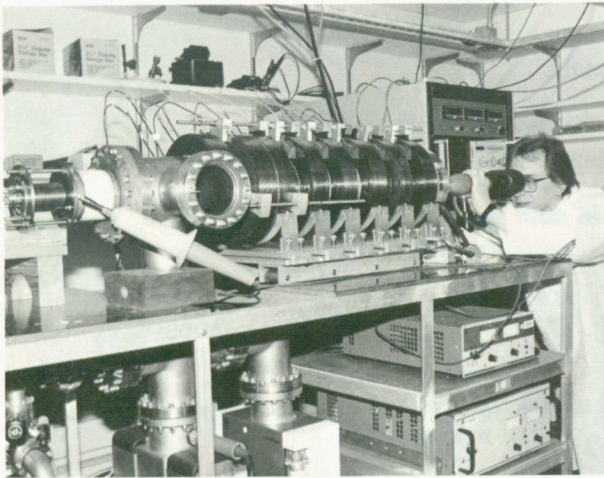

Independent Exploratory Development . . . Strapdown Sensor

Traditionally, weapon system seekers have optical elements attached to an inertially stable, gimballed platform isolated from the weapon body. Due to advances in detectors, image processors, and inertial sensors, a configuration in which all the seeker components are attached directly to the vehicle is feasible. This configuration offers lower cost and is more rugged, but also poses unique challenges. In a very successful one-year IED effort, a visible light prototype seeker was developed. This test bed will be a key element in addressing the challenges and developing the new seeker.



**Focused Technology . . .
Photonics**

One or two new technology areas are targeted each year for three years of focused activity. Photonics was one area selected in FY90, thereby establishing a major new thrust in optical science . . . with work on optical signal processing, optical digital computing and optical

materials research. Current program emphasis is on advanced processing architectures for automatic detection and recognition of relocatable targets, radar signal processing, high speed photonic switching, and optimization of photorefractive materials.

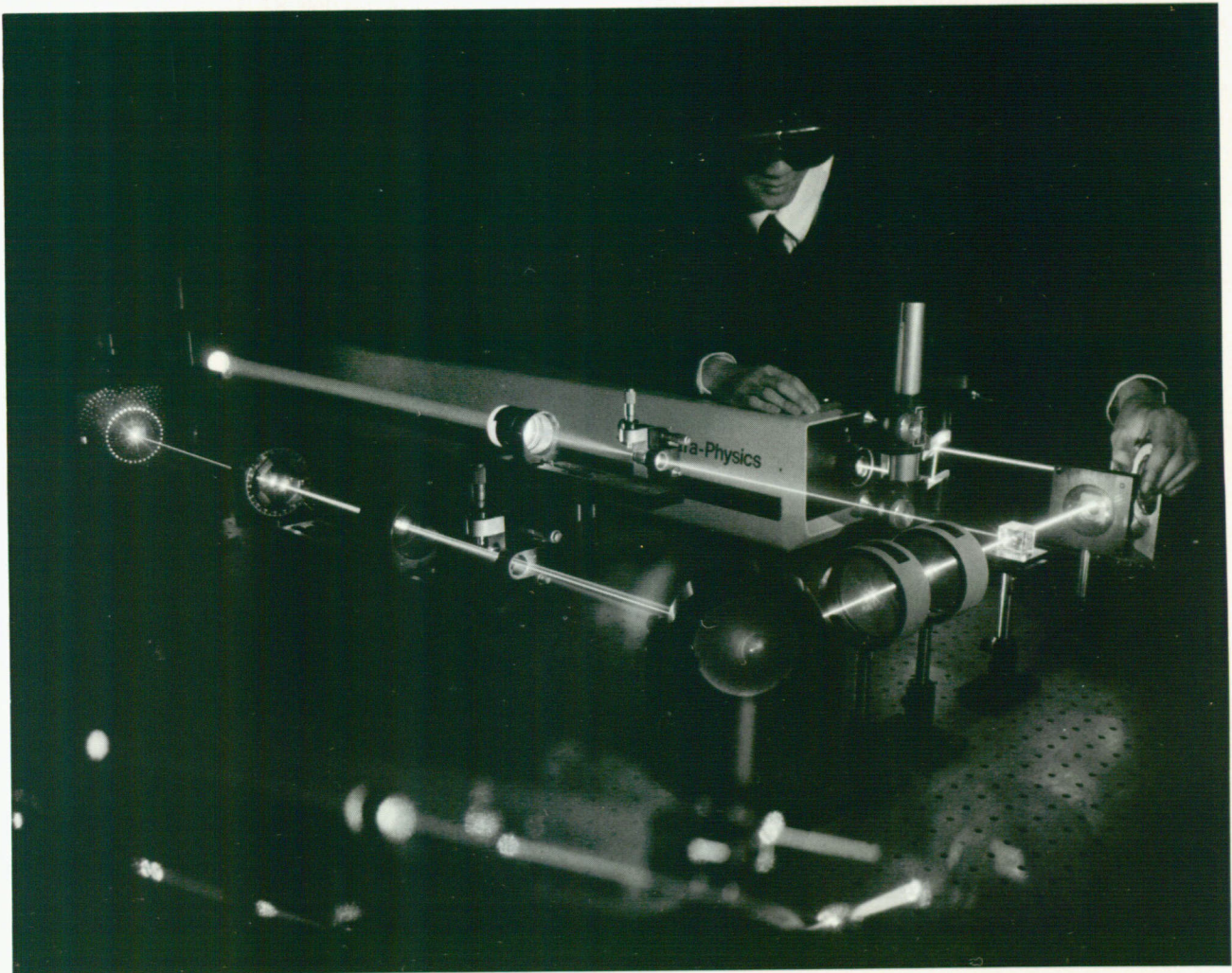

**NEW CAT 6.2 Block . . .
Engineering of Complex Systems
Technology (ECST)**

A significant enhancement of the Center's tech base posture was recently afforded by the creation of the ECST Block. The Block, established by the Office of Naval Technology in May 1990, is intended to address the development of technologies that provide

integrated, system level design capabilities for large-scale, complex systems. The real-time mission critical computational capabilities needed by the weapons control and combat systems communities are of particular concern under this program.



CAT 6.2 Block . . . Multi Sensor Detection

Current shipboard AAW sensors have severe problems detecting low flying, low observable threats at ranges near the horizon. To address this problem, a sensor system architecture has been designed and analyzed which integrates a horizon IR search sensor with a phased-array weapon control radar. Sensor data from the NAVSWC IRAMMP IR sensor and the NRL PD DEMO radar, collected during FY90, are currently being analyzed and used in algorithm development. A limited real-time demonstration

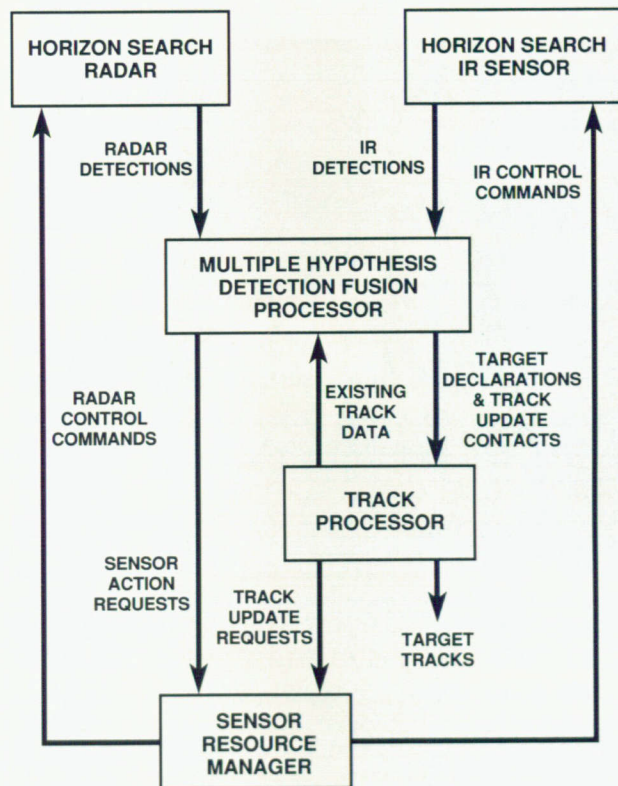

of the integrated system is planned for FY93 using the NRL radar converted to a real-time weapon control radar, a jointly developed NAVSWC/ITT focal plane array IRST, and a NAVSWC-developed integration processor.

Balanced Technology Initiative . . . Target Acquisition for Ship Defense (TASD)

TASD is a dual-band (Ku/W) radar system designed to track two low flying targets (one incoming and one outgoing) simultaneously with a differential track angle accuracy of 0.1 mrad in the presence of multipath and sea clutter out to 5.5 nm. The TASD system will be delivered in the near future. It will be used to conduct radar characterization tests at the Potomac River Test Site in support of defining a tactical dual-band tracking radar. In addition, propagation and clutter testing will be conducted at W-band.

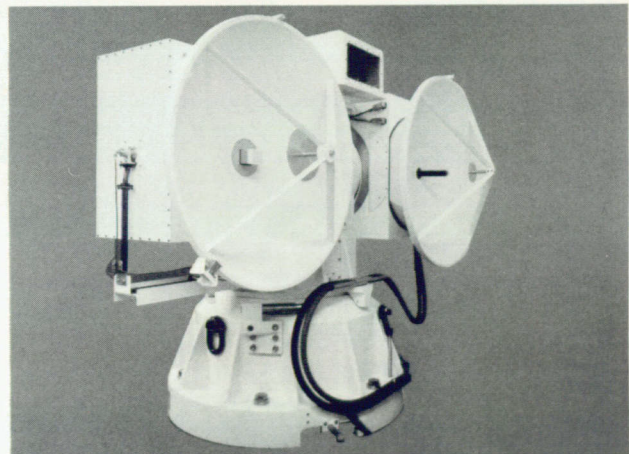

5

Special Events

Several aspects of the NAVSWC technology base program might be termed special events...

- Topical Conference Series
 - Science and Technology Lecture Series for Managers
 - IR/IED Navy-Wide Conference
 - Post-Doctoral Program
 - Summer Faculty Research Program
- Science and Technology Excellence Award
 - Independent Research Excellence Award
 - Independent Exploratory Development Excellence Award
 - Technology to Sea Award

Dr. James Heagy (center) is in his second year as an Office of Naval Technology Post Doctoral Fellow. Dr. William Ditto (left) and Dr. Steven Rauseo, both recent NAVSWC “post docs,” are now permanent employees. All three are engaged in nonlinear dynamics research.



Facets of the program that reflect, promote,
and feed a healthy technology base

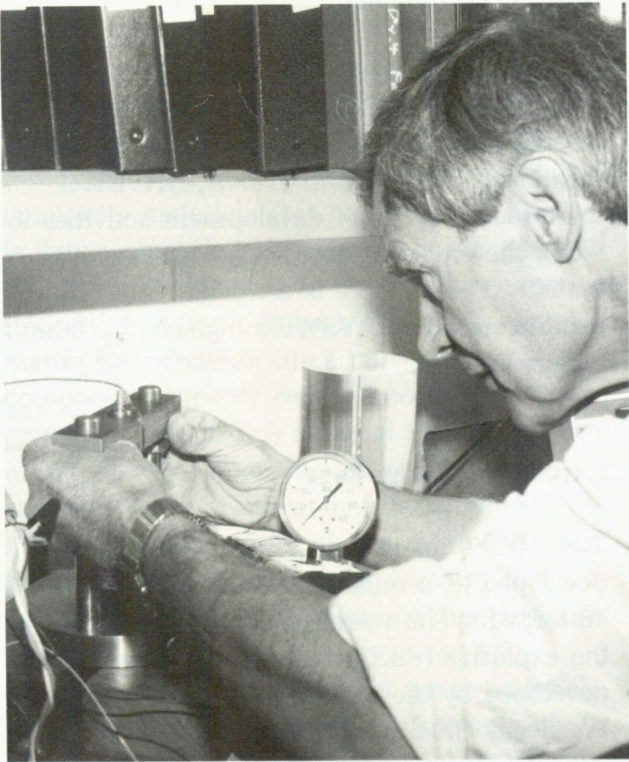

Professor Romeo Segnan, head of the Physics Department at American University, has been a participant in the Office of Naval Research Summer Faculty Research Program at NAVSWC for the past four summers. He performs basic research studies with the Magnetic Materials Group in the Research and Technology Department.

James Queen of the Electronics Systems Department receives the Center's Science and Technology Excellence Award for his work on the collection and analysis of radar sea clutter. The Award was presented by Captain Robert P. Fuscaldo, NAVSWC Commander, at the Year End Ceremony, December 1989. The Award



carries with it the recognition of being a Center Technology Fellow and \$100K of funding for an IR or IED project.



Dr. Elihu Zimet, of the Office of Naval Technology, gives the keynote address for a Topical Conference on Futuristic Point Defense. These internal, one day, topical conferences are designed to promote interaction among NAVSWC's scientific, engineering, line and program management communities.

Technology Base Transitions

The quality of organizationally supported science and technology is measured by the impact that it has in realizing the goals of the organization, as well as the influence it has on the technical community outside of the organization. In either case, the results are used. Depicted here are a few examples of the utilization of NAVSWC in-house, hands-on scientific and technological results. A recent internal report, *Science and Technology Transitions* (NAVSWC MP 90-332, August 1990), lists over 200 examples of NAVSWC-developed technology used by industry, government or universities.

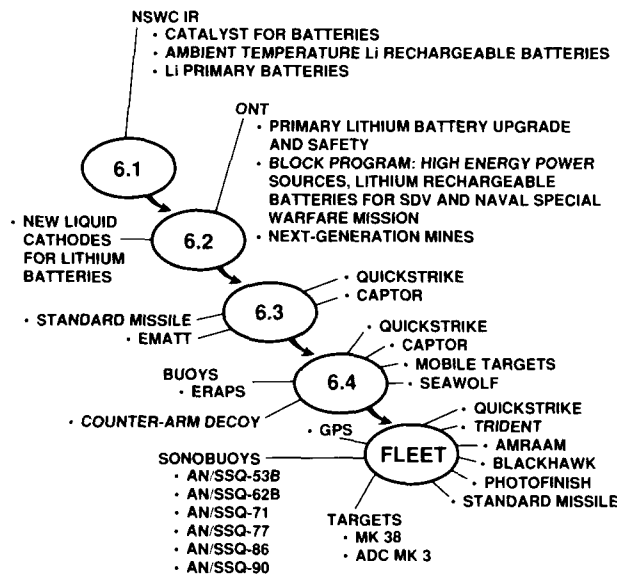

Battery Technology

Recognizing in the early 1970s that the advent of high-energy lithium batteries was potentially the most significant advance in battery technology since World War II, NAVSWC undertook a series of development activities to adopt the emerging technology to Navy systems. Shown here is a wealth of transitions experienced by NAVSWC's high-energy lithium battery program.

Explosives Technology

The MK 50 lightweight torpedo is being developed as a replacement for the Navy's MK 46 torpedo. The warhead concept, including the explosive (PBXN-110) for this torpedo, was developed by the 6.2 Explosives and Undersea Warheads Block program to provide high lethality against the current and near-future ASW threat. This warhead was transitioned into the Advanced Development program in 1983. Continuing 6.2 efforts led to transition of a MOD 1 warhead in 1987. The 6.2 block program also transitioned an entirely new warhead concept for the MK 50 torpedo into a Balanced Technology Initiative (BTI) program in the FY87-88 time frame. This new warhead is planned as a MOD 2 upgrade to MK 50.

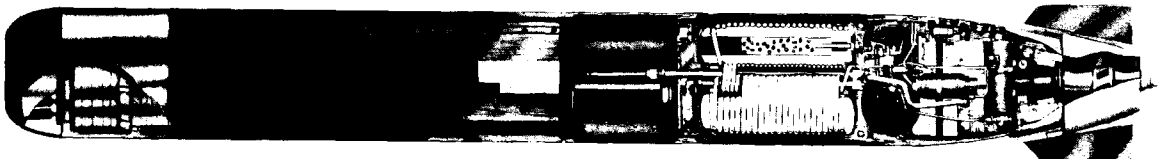

Materials Technology

The NAVSWC materials program has contributed to cost control of the TRIDENT II guidance system by the development of a discontinuous silicon carbide-aluminum (SiC-Al) composite material. This metal-matrix composite is light weight, but has the structural stability hitherto available only in the twice as expensive material, beryllium. Substitution of the metal matrix for beryllium in certain guidance components directly reduced costs, and competition from this material reduced costs of beryllium components from the sole U. S. supplier. Work on metal-matrix composites was initiated on 6.2 funding in the mid-1970s. By the early 1980s the technology was maturing sufficiently to allow focusing for this particular application. A five-year effort in the 6.2 program led to the instrument cover material selection by the project office. Currently, the metal-matrix material is also being qualified for use in the electronics shell.

Missile Technology

NAVSWC's technology base has made a variety of major contributions to STANDARD MISSILE. Most of the warheads, either deployed or in development, are direct transitions from a NAVSWC block program. Other contributions include the fore/aft dual-beam fuze concept, adaptive boresight error compensation (to be incorporated in SM Block IV), and input to airframe design via aerodynamic prediction and design codes.

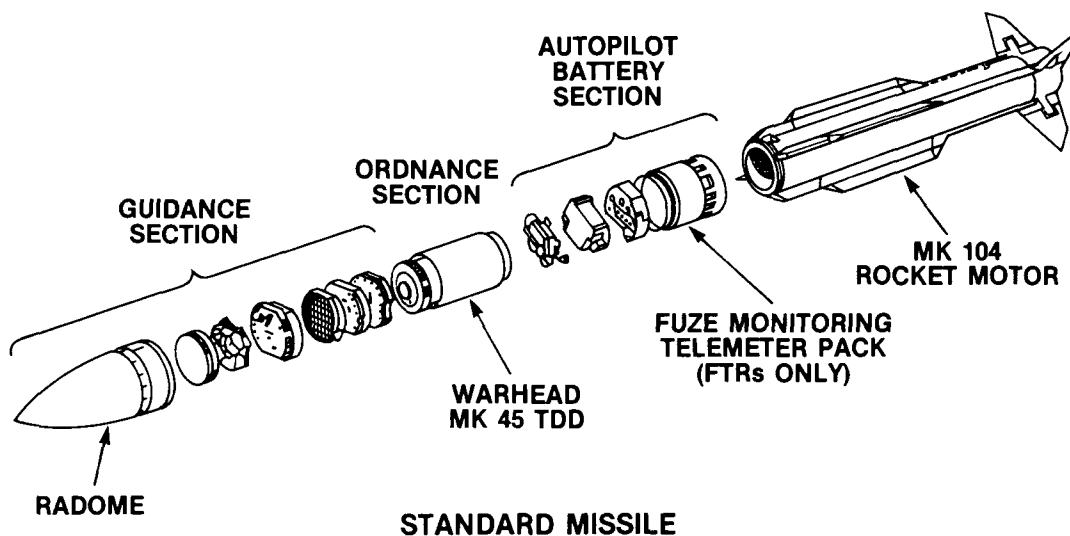

Publications, Patents and Licenses

NAVSWC has an outstanding track record of publications in scientific journals as well as patent activity. Scientists and engineers publish nearly 100 papers in archival journals each year, and are granted approximately 50 patents per year. Also, as the result of the new Federal Technology Transfer Law, the Center grants patent and software licenses to industry, enabling NAVSWC inventors to share in the royalties.

Below, laboratory experimental data represents chaotic motion in phase space. A breakthrough in the field occurred in August 1990 when NAVSWC scientists demonstrated control of chaotic motion. Such control has never before been accomplished. This knowledge could have widespread ramifications. . . in mechanical design, medicine, economics, signal processing

and many other fields. Precursors to this demonstration of control were two important publications by the NAVSWC group: "Experimental Observation of Crisis Induced Intermittency and Its Critical Exponent," W. L. Ditto, S. Rauseo, R. Cawley, C. Grebogi, G. H. Hsu, E. Ott, H. T. Savage, R. Segnan, M. Spano and J. A. Yorke, *Physical Review Letters* **63**, 923 (1989) and "Experimental Observation of a Strange Nonchaotic Attractor," W. L. Ditto, M. L. Spano, H. T. Savage, S. N. Rauseo, J. Heagy and E. Ott, *Physical Review Letters*, **65**, 533 (1990). The latest work on control of chaotic motion has been accepted for publication in *Physical Review Letters*.

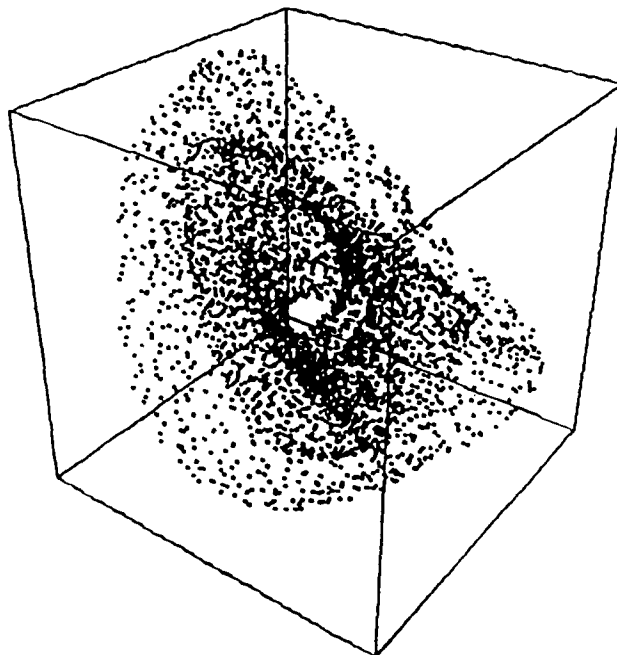

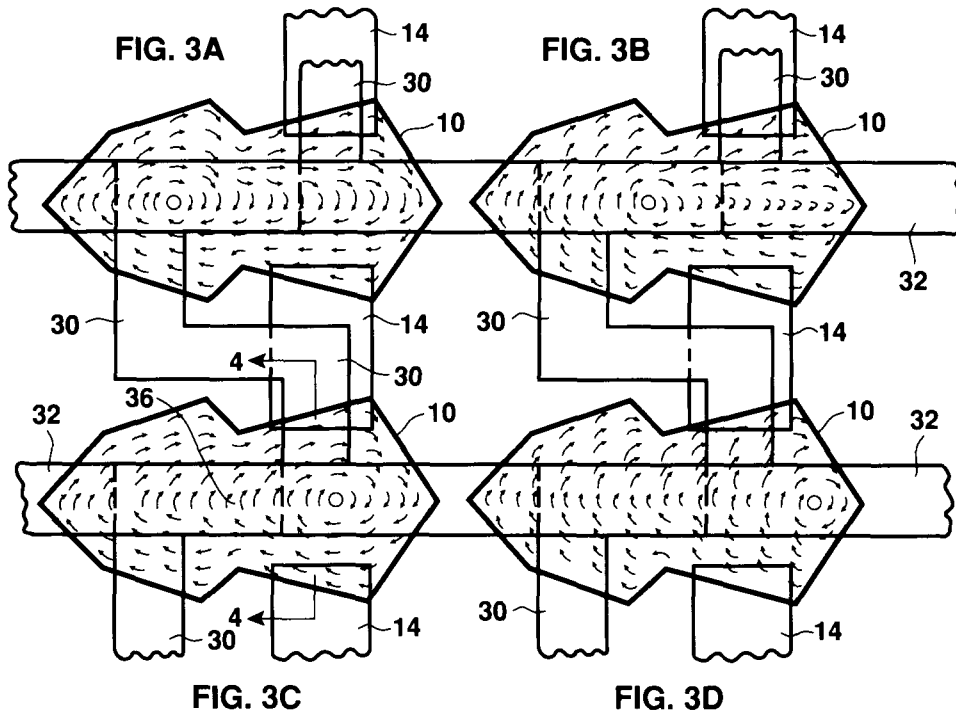

Memory elements of the Crosstie Random Access Memory (CRAM). CRAM is a thin film, nonvolatile, read-write magnetic memory with an access time of 100 ns. NAVSWC has granted a license to manufacture this invention to

Megabyte Memories, Inc. The patent is "Block-Line Memory Element and RAM Memory," Pat. No. 4,901,278; Feb. 13, 1990, inventor L. J. Schwee.

