

#15277RL

SUPERIOR TECHNOLOGY FOR A SUPERIOR ARMY

# **U.S. Army/TACOM LCMC Path Forward for Heavy Duty Diesel Vehicles/Engines**

## **October 27, 2005**

**Dr. Peter Schihl  
RDECOM-TARDEC Propulsion Lab**

**Ms. Parminder Khabra  
RDECOM-TARDEC Engineering Group**

**Mr. Luis Villahermosa  
RDECOM-TARDEC Fuels and Lubricants Team**

**TARDEC**

U.S. ARMY TANK-AUTOMOTIVE RESEARCH DEVELOPMENT AND ENGINEERING CENTER

#15277RL

## Report Documentation Page

*Form Approved*  
*OMB No. 0704-0188*

Public reporting burden for the collection of information is estimated to average 1 hour per response, including the time for reviewing instructions, searching existing data sources, gathering and maintaining the data needed, and completing and reviewing the collection of information. Send comments regarding this burden estimate or any other aspect of this collection of information, including suggestions for reducing this burden, to Washington Headquarters Services, Directorate for Information Operations and Reports, 1215 Jefferson Davis Highway, Suite 1204, Arlington VA 22202-4302. Respondents should be aware that notwithstanding any other provision of law, no person shall be subject to a penalty for failing to comply with a collection of information if it does not display a currently valid OMB control number.

1. REPORT DATE <b>27 OCT 2005</b>	2. REPORT TYPE <b>N/A</b>	3. DATES COVERED <b>-</b>		
4. TITLE AND SUBTITLE <b>U.S. Army/TACOM LCMC Path Forward for Heavy Duty Diesel Vehicles/Engines</b>		5a. CONTRACT NUMBER		
		5b. GRANT NUMBER		
		5c. PROGRAM ELEMENT NUMBER		
6. AUTHOR(S) <b>Schihl,Peter; Khabra,Parminder; Villahermosa,Luis</b>		5d. PROJECT NUMBER		
		5e. TASK NUMBER		
		5f. WORK UNIT NUMBER		
7. PERFORMING ORGANIZATION NAME(S) AND ADDRESS(ES) <b>US Army RDECOM-TARDEC 6501 E 11 Mile Rd Warren, MI 48397-5000</b>		8. PERFORMING ORGANIZATION REPORT NUMBER <b>#15277 RC</b>		
9. SPONSORING/MONITORING AGENCY NAME(S) AND ADDRESS(ES)		10. SPONSOR/MONITOR'S ACRONYM(S) <b>TACOM/TARDEC</b>		
		11. SPONSOR/MONITOR'S REPORT NUMBER(S) <b>#15277 RC</b>		
12. DISTRIBUTION/AVAILABILITY STATEMENT <b>Approved for public release, distribution unlimited</b>				
13. SUPPLEMENTARY NOTES				
14. ABSTRACT				
15. SUBJECT TERMS				
16. SECURITY CLASSIFICATION OF:			17. LIMITATION OF ABSTRACT <b>SAR</b>	
a. REPORT <b>unclassified</b>	b. ABSTRACT <b>unclassified</b>	c. THIS PAGE <b>unclassified</b>		18. NUMBER OF PAGES <b>32</b>
				19a. NAME OF RESPONSIBLE PERSON

# Acknowledgements

- BG Patrick O'Reilly
- Ms. Violet Kristoff,  
TACOM Legal Office



# Agenda

- **2006/2007 Heavy-Duty On-Road Fuel and Engine Exhaust Emission Standards**
  - Regulation Approach
  - Potential Impacts on DOD
  - DOD interaction with EPA
  - Current production Systems under an NSE\*
- **Blanket NSE\* for Exhaust Emissions Status and Discussion**
- **Pollution Control Technology Discussion**
  - Evolution of Emission Controls
  - Exhaust Gas Recirculation
  - After Treatment Devices
- **Fuels and Lubricants Discussion**
- **Solution Pathways**

\*National Security Exemption

# Regulatory Approach

**EPA finalized motor vehicle diesel fuel regulations and the heavy duty diesel on-road exhaust emissions regulations in January 2001.**

**Took a dual approach to reduce air emissions by:**

1. Reduction in diesel fuel sulfur content to 15ppm starting June 2006.
  - Enable the use of exhaust system aftertreatment devices
  - JP-8 specification calls for < 3000 ppm!
2. Establish stringent exhaust emission standards - effective January 2007.
  - Require aftertreatment device(s)

**(Both regulations implemented with a phased approach)**

## Potential Impacts to DoD

- **Ground tactical vehicles (i.e. HEMMT, PLS, HMMWV) fielded in the U.S. required to meet the fuel 15 ppm sulfur regulation**
  - JP-8 does not meet this requirement
- **Procure vehicles with pollution control technology**
  - Potential performance degradation (fuel consumption, reliability, durability)
  - The current leading pollution control technology candidates are intolerant to high sulfur fuel
- **Nebulous world wide operation since low sulfur fuel is not available world wide:**
  - Low sulfur diesel fuel is an enabler for pollution control devices

**(Combat vehicles (i.e. Abrams, Bradley, Stryker) are automatically exempt under 40 CFR, 89.908)**

# DoD Interaction with EPA

- **Fuel and Emissions Strategies**

- **Seek NSE for JP-8 exclusion from 2006 diesel fuel regulations**

*In 1995, EPA determined that JP-8 did not meet EPA's definition of diesel fuel, thus is not regulated as such today. ( letter from EPA to Ms. Goodman, DUSD, 1995.)*

- **Seek NSE from meeting MY2007 diesel heavy-duty, on-road exhaust emissions standards**

- **End Result:**

- **DoD provided data to EPA in 2003 on tactical vehicles to obtain a NSE from 2006 diesel fuel regulations**
- **'blanket NSE' granted for MY 2007+ diesel heavy-duty, on-road exhaust emission standards (August 23, 2005)**
- **THESE NSEs ARE ONLY FROM THE ON-ROAD, HEAVY-DUTY EMISSION AND FUEL REGULATIONS**

## **Approach for MY 2007+ Exhaust Emissions NSE**

- **Typical engine characteristics supplied to EPA for an exhaust emissions NSE:**
  - Engine model, engine compliance status, name of Vehicle Family, time frame for the NSE, contract # (if available)
- **Today, PM TV does not have the above information for the future tactical vehicle, thus NSE strategy is:**
  - Establish a generic NSE, using vehicle family names
  - Provide additional information at the time of contract award
  - Transfer the NSE to engine manufacturers upon contract award

## **“Blanket” NSE for Exhaust Emissions Status and Discussion**

- **“EPA hereby approves your blanket NSE request for all the DOD ‘tactical fleet’ that is subject to regulations at 40 CFR Part 85 and Part 86. This ‘tactical fleet’ includes the tactical military vehicles (TMVs) specified on the ‘Tactical On-Highway Fleet’ list (Enclosure 1) and all other TMVs meeting the requirements of the foregoing ‘tactical vehicle’ definition.’ – August 23, 2005; K. Jennings, Manager, Engine Programs Group (EPA)**
- **Tactical On-Highway Fleet (Enclosure 1):**
  - Light Tactical Vehicle: HMMWV
  - Family Medium Tactical Vehicles: MTV, LMTV
  - Heavy Tactical Vehicles: HEMTT, HET, PLS, Line Haul Tractor, Light Equipment Transporter, Heavy Dump Truck, Engineer Tractor
  - Current R&D: Smart Truck, FTTS, COMBATT, HMEE

## “Blanket” NSE for Exhaust Emissions Status and Discussion

- Tactical Vehicle Definition: A motor vehicle designed to military specifications **or** a commercial design vehicle modified to military specification to meet direct transportation support to combat or tactical operations **or** for training of personnel for such operations.
- EPA Acknowledgements
  - High sulfur fuel used in future engines that include aftertreatment could result in engine failure, drivability problems, and permanent destruction of the emission control system
  - “New TWV procurements can’t contain engines with pollution control technology that is intolerant to sulfur without affecting reliability”
  - The military will integrate 2004 on-road, heavy-duty emissions compliant engines into propulsion systems ***whenever technically feasible***

## Terms & Utilization of the “Blanket” NSE

- **Terms of the “blanket” NSE from 2007 standards**
  - The Army/TACOM will integrate 2004 emission standard compliant engines into propulsion systems *whenever technically feasible*
    - must meet vehicle mobility/propulsion requirements
  - After formal selection of a production contract, the Army shall supply EPA with vehicle details (type, engine model, quantity)
  - Subsequent formal transfer of NSE to engine manufacturer.
  
- **TACOM process for NSE transfer for each contract**
  - Develop contract language
    - Contractor will complete a standard form
    - Government review
    - Request NSE transfer from EPA to Contractor

## Future Issues: Non-Road Equipment

- The EPA definition of the *nonroad engine* is based on the principle of mobility/portability, and includes engines installed on (1) self-propelled equipment, (2) on equipment that is propelled while performing its function, or (3) on equipment that is portable or transportable, as indicated by the presence of wheels, skids, carrying handles, dolly, trailer, or platform [40 CFR 1068.30]. In other words, nonroad engines are all internal combustion engines except motor vehicle (highway) engines, stationary engines (or engines that remain at one location for more than 12 months), engines used solely for competition, or engines used in aircraft.
- Effective May 14, 2003, the definition of nonroad engines was changed to also include all diesel powered engines—including stationary ones—used in agricultural operations in California. This change applies only to engines sold in the state of California; stationary engines sold in other states are not classified as nonroad engines.
- **Examples of regulated applications include farm tractors, excavators, bulldozers, wheel loaders, backhoe loaders, road graders, diesel lawn tractors, logging equipment, portable generators, skid steer loaders, or forklifts.**

# Future Issues: Non-Road Equipment

- Non-Road regulations
  - EPA has taken a similar approach with non-road equipment by reducing sulfur in the diesel fuel and exhaust emission standards as a single system, finalized June 2004.
    - Fuel regulations starting in July 2007 (500 ppm)
      - phase in period to June 2010 (15 ppm)
    - Exhaust emissions regulations begin MY2008 (Tier 4)
    - Impact on DoD is similar to heavy-duty on-road vehicle regulations
  - **STRATEGY: Obtain a NSE from fuel as well as exhaust emissions regulations/standards**

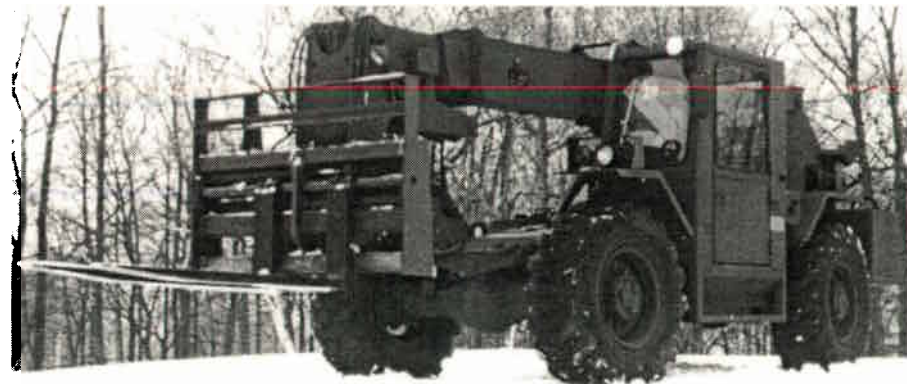

# **Emission Control Technology Discussion**

**TARDEC**

U.S. ARMY TANK-AUTOMOTIVE RESEARCH DEVELOPMENT AND ENGINEERING CENTER

## Evolution of Heavy-Duty Engine Emission Control – 2002/2004

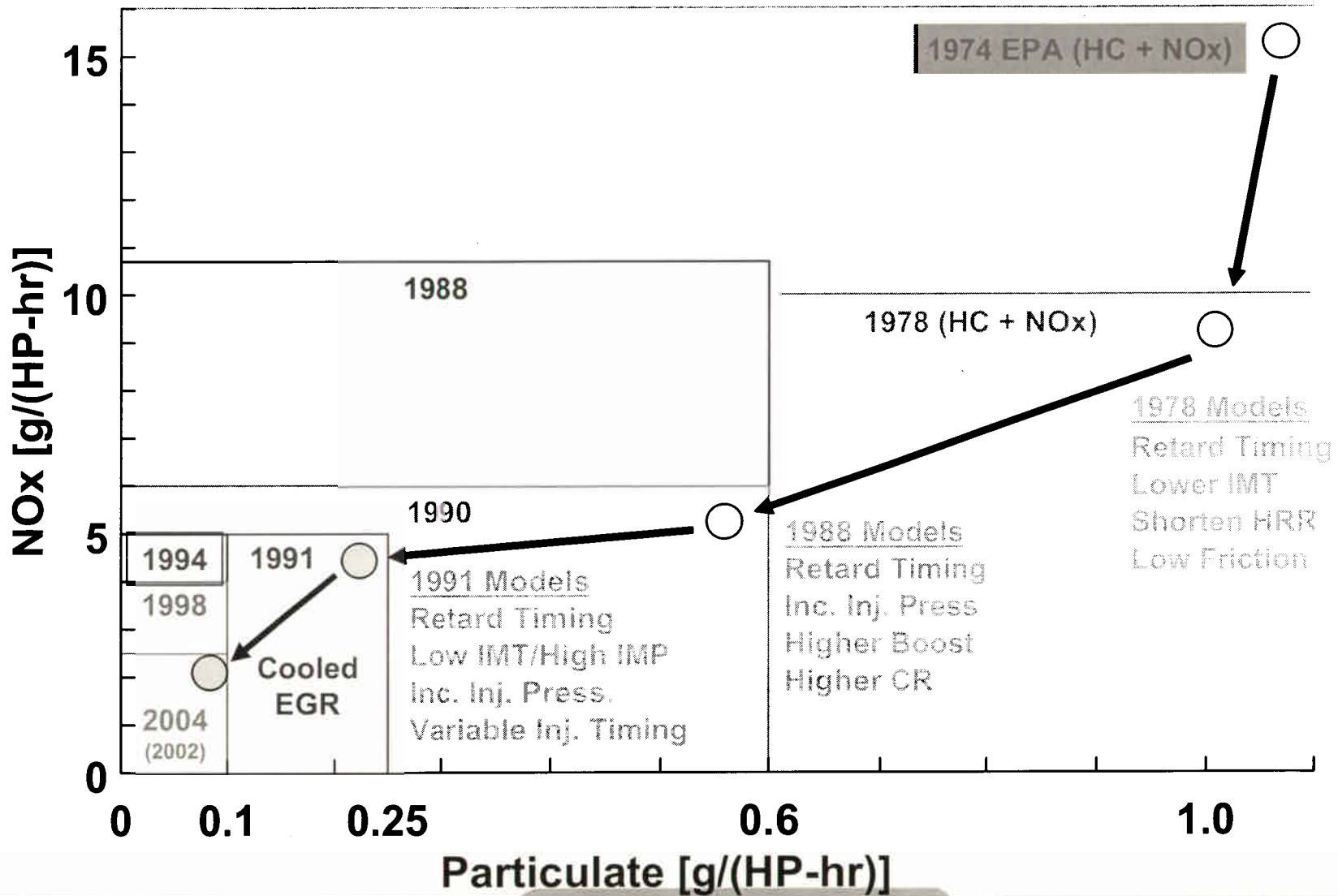

# Evolution of Heavy-Duty Engine Emission Control – 2007

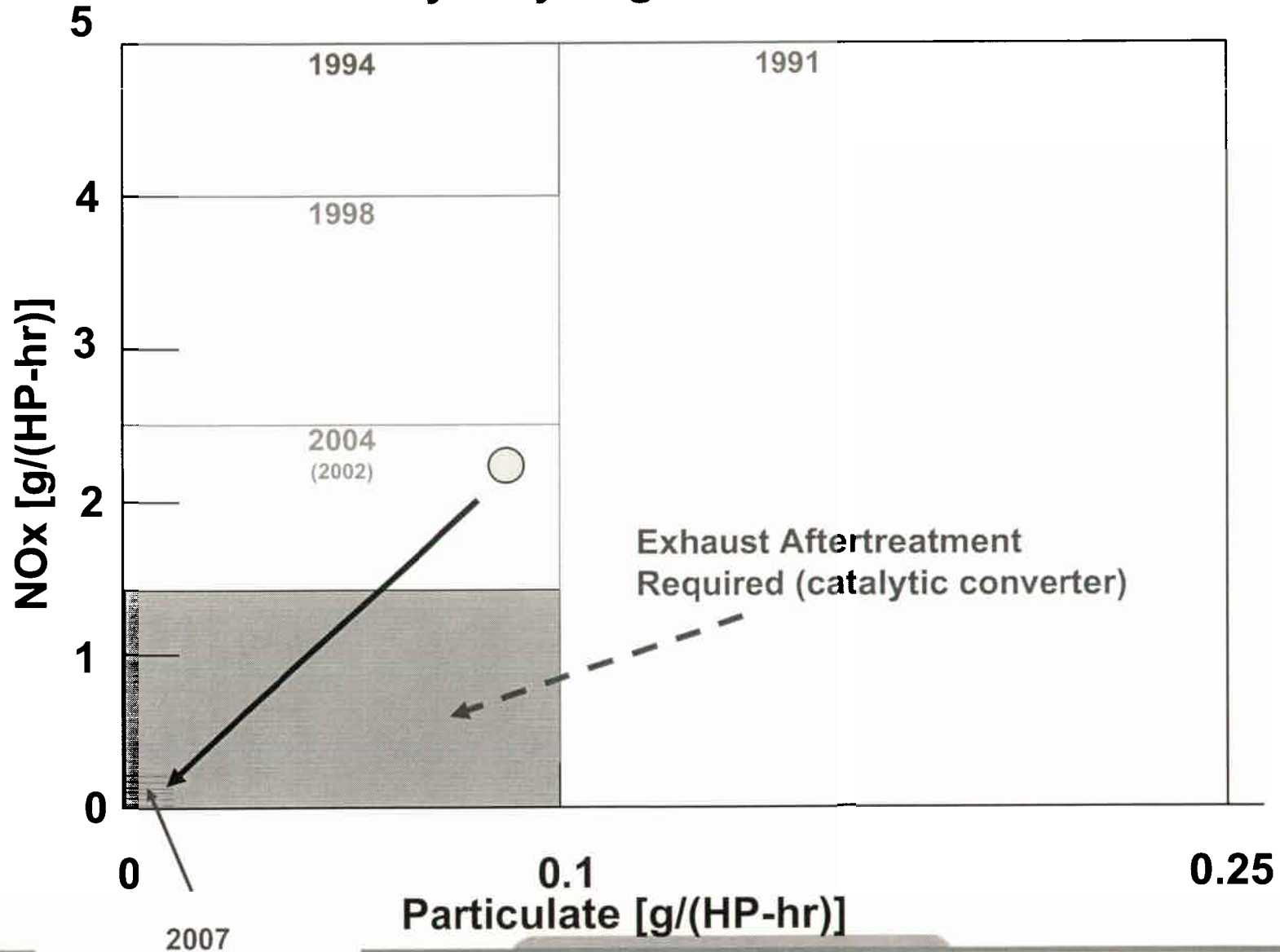

## Impact of 2002/2004 Standards on Commercial Heavy-Duty Diesel Engines

- Cooled Exhaust Gas Recirculation (EGR)
- ACERT™ – Advanced Combustion and Emissions Reduction Technology

## Impact of 2007/2010 Emission Standards on Commercial Heavy-Duty Diesel Engines

- Cooled Exhaust Gas Recirculation (EGR) with advanced combustion and closed-loop engine system controls
- ACERT™ – Advanced Combustion and Emissions Reduction Technology plus aftertreatment (catalytic converter) and closed-loop engine system controls along with low pressure EGR loop
- New combustion regimes that may require specified fuel properties

## What is cooled EGR?

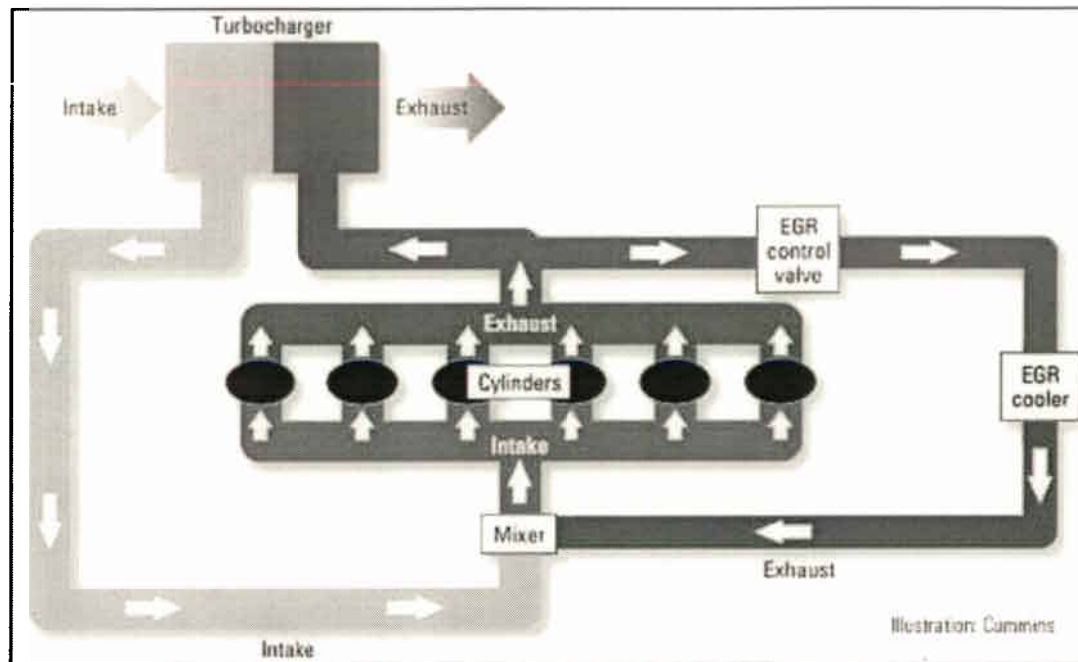

- Reduce nitrous oxides ( $\text{NO}_x$ ) through 'cooler' combustion temperatures
- Recirculate and cool exhaust gas downstream of turbine (turbocharger) ; require back pressure restriction to flow exhaust gas to intake system (**fuel economy penalty**)
- **Cool exhaust gas 400 – 800 F** before dumping into intake system; **additional engine system cooling requirement ( ~30% for heavy-duty engines and ~10% for light duty engines)**; non-ram air scenarios will have additional fuel economy penalty
- Temperature control of EGR crucial in order to avoid formation of **sulfuric acid that expedites engine wear and reduces durability of EGR cooler**
- This concept introduces particulates into cylinder ; **requires more frequent oil change w/o certification of proper lubricant**

## What is ACERT™?

- Caterpillar trademark non-EGR solution
- Limited variable intake valve timing ; **extra valve train sophistication**
  - ‘cooler’ combustion temperatures
- **Two stages of turbocharging (single stage for smaller displacement engines)**
- **Additional charge air cooling necessary ; increase in required engine system heat rejection – not as significant impact as cooled EGR**
- **Passive oxidation catalyst (catalytic converter)**
- **Fuel economy penalty comparable to EGR engines**

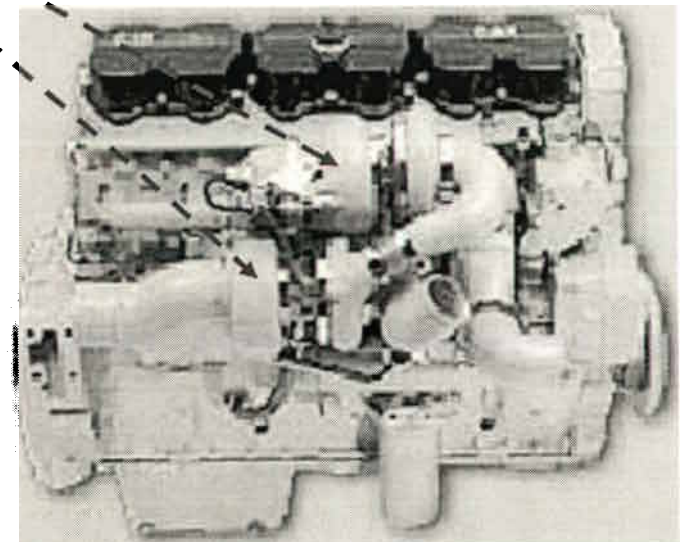

## 2007 (2010) Emission Issues : Aftertreatment Devices (example)

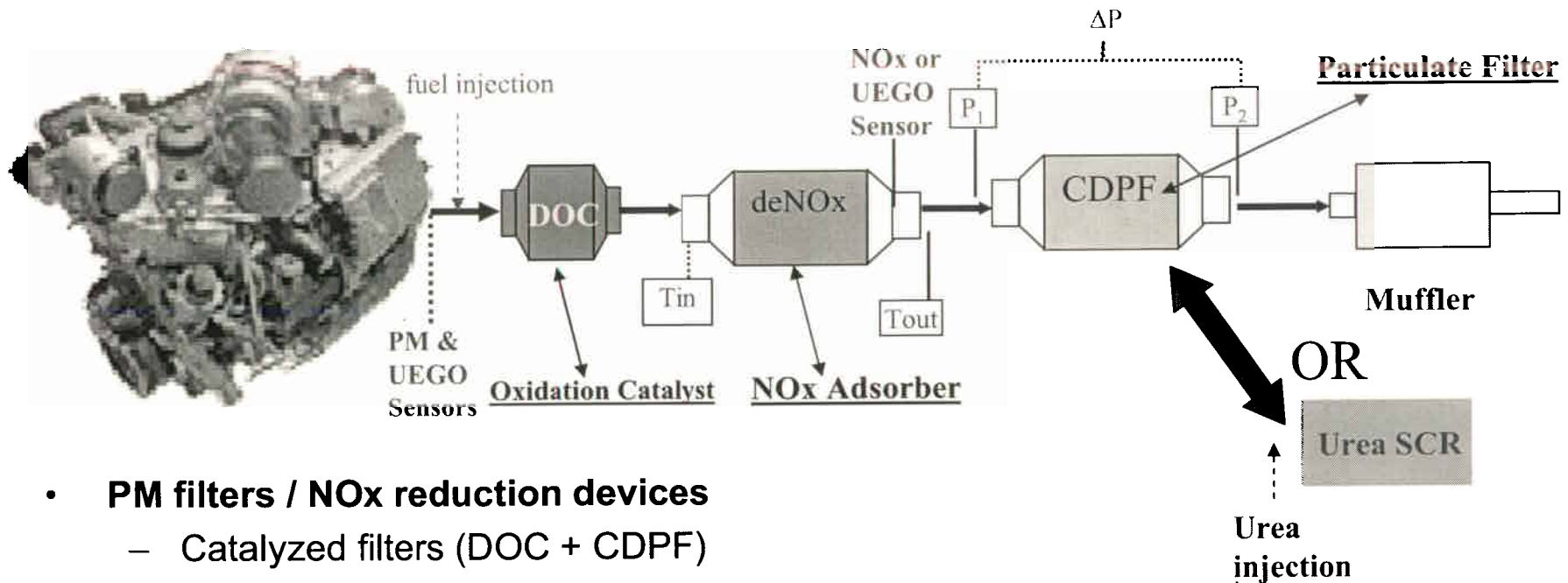

- **PM filters / NOx reduction devices**
  - Catalyzed filters (DOC + CDPF)
  - NOx trap (adsorber) vs. Urea SCR (selective catalytic reductant)
  - Additional space claim , **conservatively 5 x engine displacement**
- **NOx trap requires 15 ppm fuel sulfur level**
- Likely to include high levels of EGR in additional to NOx aftertreatment device
  - higher heat rejection (~ 50% increase vs. MY1998)
- Push toward new oil formulation to extend CDPF lifetime
- Urea SCR requires on-vehicle, urea storage tank

**2007 (2010) Emission Issues : Aftertreatment Devices (example)**

**Potential ACERT Solution**

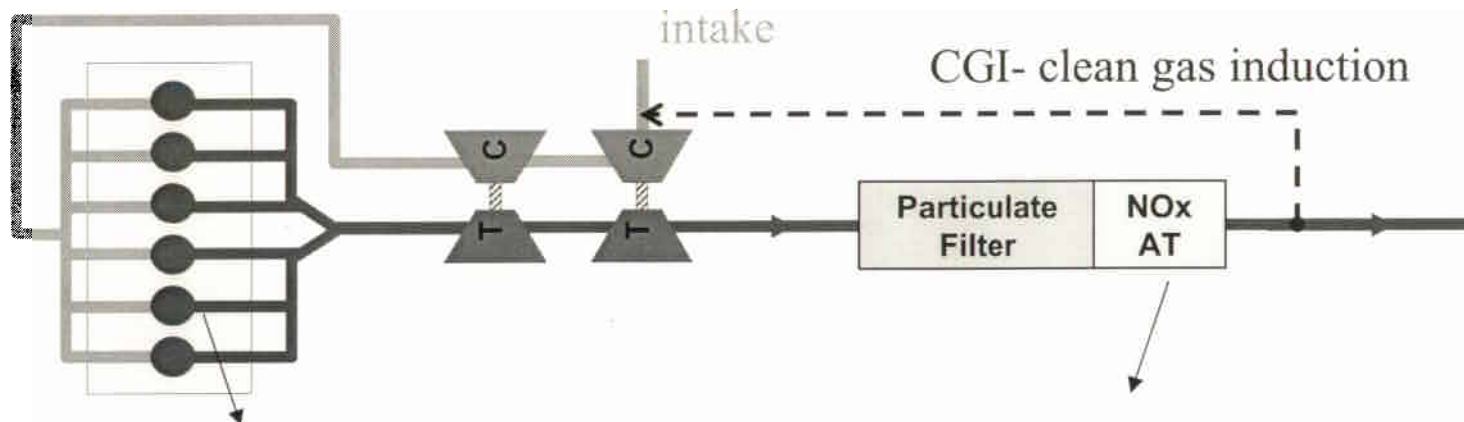

**Engine NOx Technology**

Advanced  
Diesel  
Combustion

**Aftertreatment NOx Technology Options**

DeNOx  
Catalyst

NOx  
Adsorber

Urea  
SCR

## New Combustion Regimes

- High Pressure Rise Strategies: HCCI, PCCI, etc.
  - fuel ignition quality and evaporation characteristics important
  - JP-8 'loose' property specifications, i.e. CN dependent on supply source

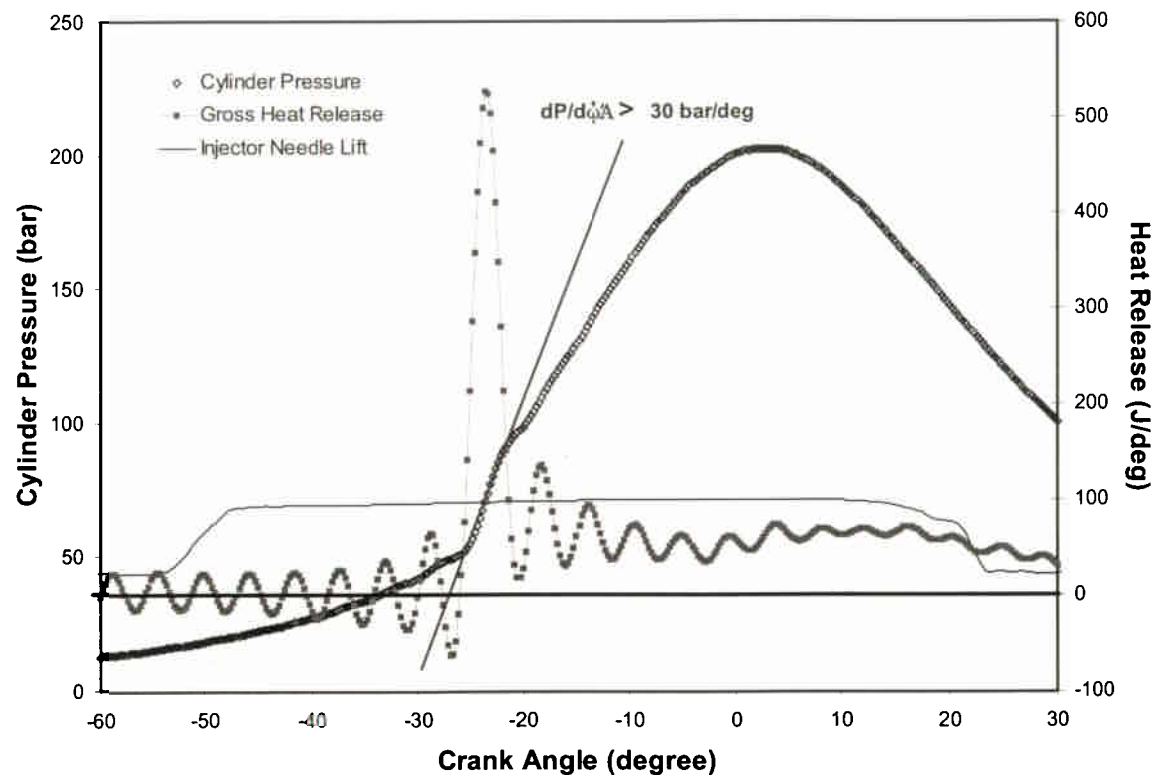

# Fuels and Lubricants Discussion

## JP-8 Property Specifications

- **Sulfur content: max. 3000 ppm**
- Aromatics: max. 25%
- Specific gravity: 0.775 – 0.84
- Evaporation Characteristics:
  - 10% recovery: max. 205 C (186 C)
  - End point: max. 300 C (330 C)
- Net Heating Value: min. 42.8 MJ/kg
- **Cetane Index: none**

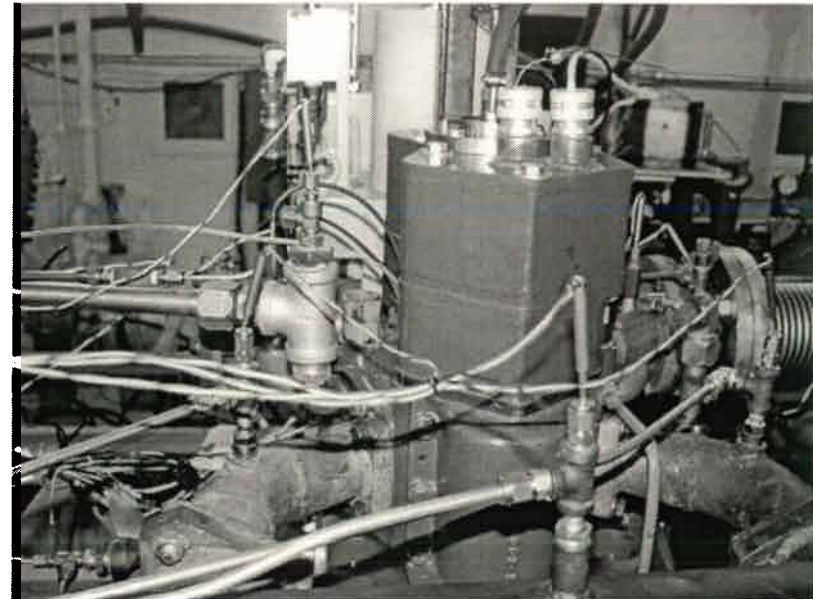

# JP-8 Fuel Sulfur Content

## Example: Fuel Supply in Iraq

- **2002 Petroleum Quality Information System (PQIS) report**
  - 44 million gallons procurement sample
  - **971 ppm mean sulfur (70 to 1500 ppm range)** based on < 50 samples
- **July 2003 data**
  - 100 – 400 ppm
- **2004 PQIS Report and early 2005 samples**
  - **878 ppm mean sulfur**
  - note: 52% of samples > 1000 ppm and 24% samples < 200 ppm)
- Reference – MIL-DT-83133 JP-8 allows up to 3,000 ppm sulfur.

# JP-8 Fuel Sulfur Content

## Example: Fuel Supply in Iraq

JP-8 Sulfur Concentration Samples from Iraq (2004)

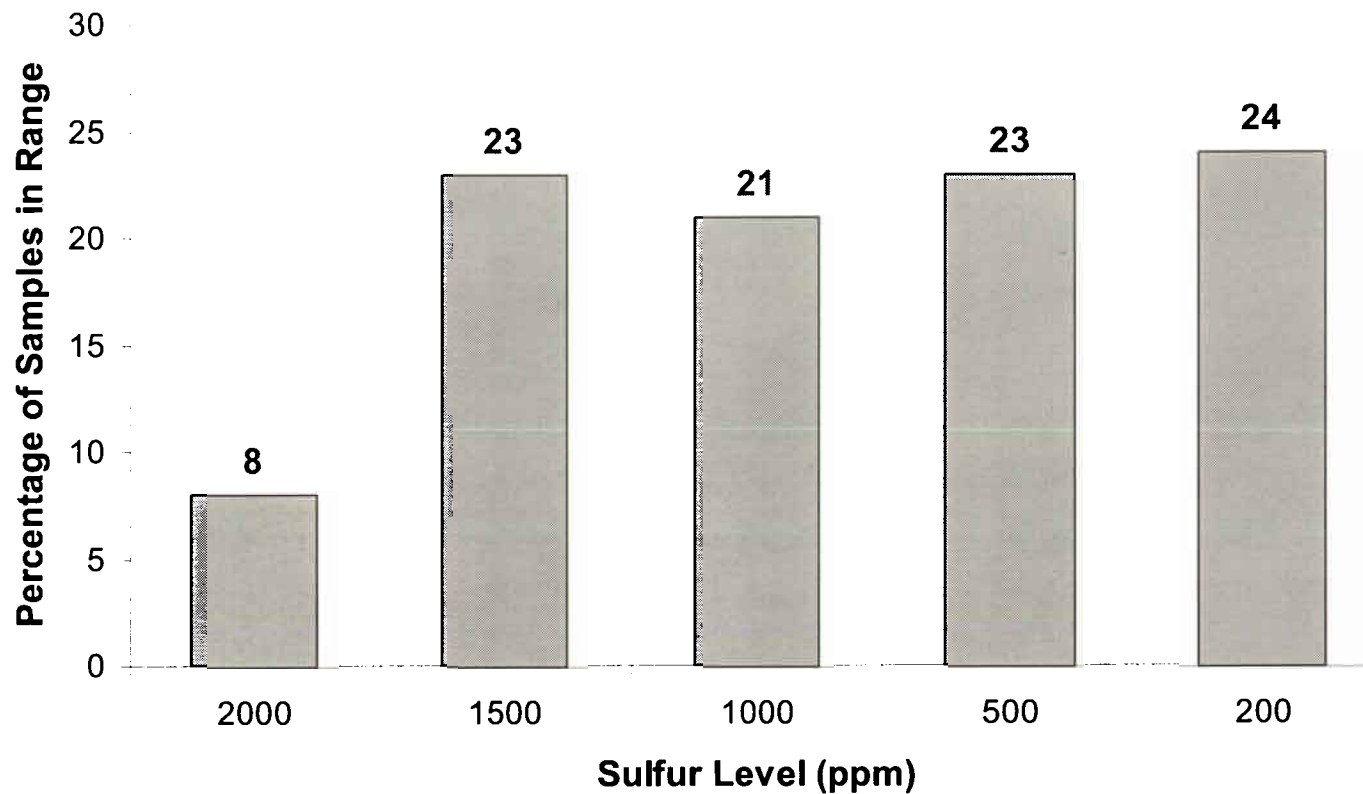

# Impact of Emission Standards on Military Heavy-Duty Diesel Engine/Transmission Oils (E/TO)

Increasing performance and test costs 

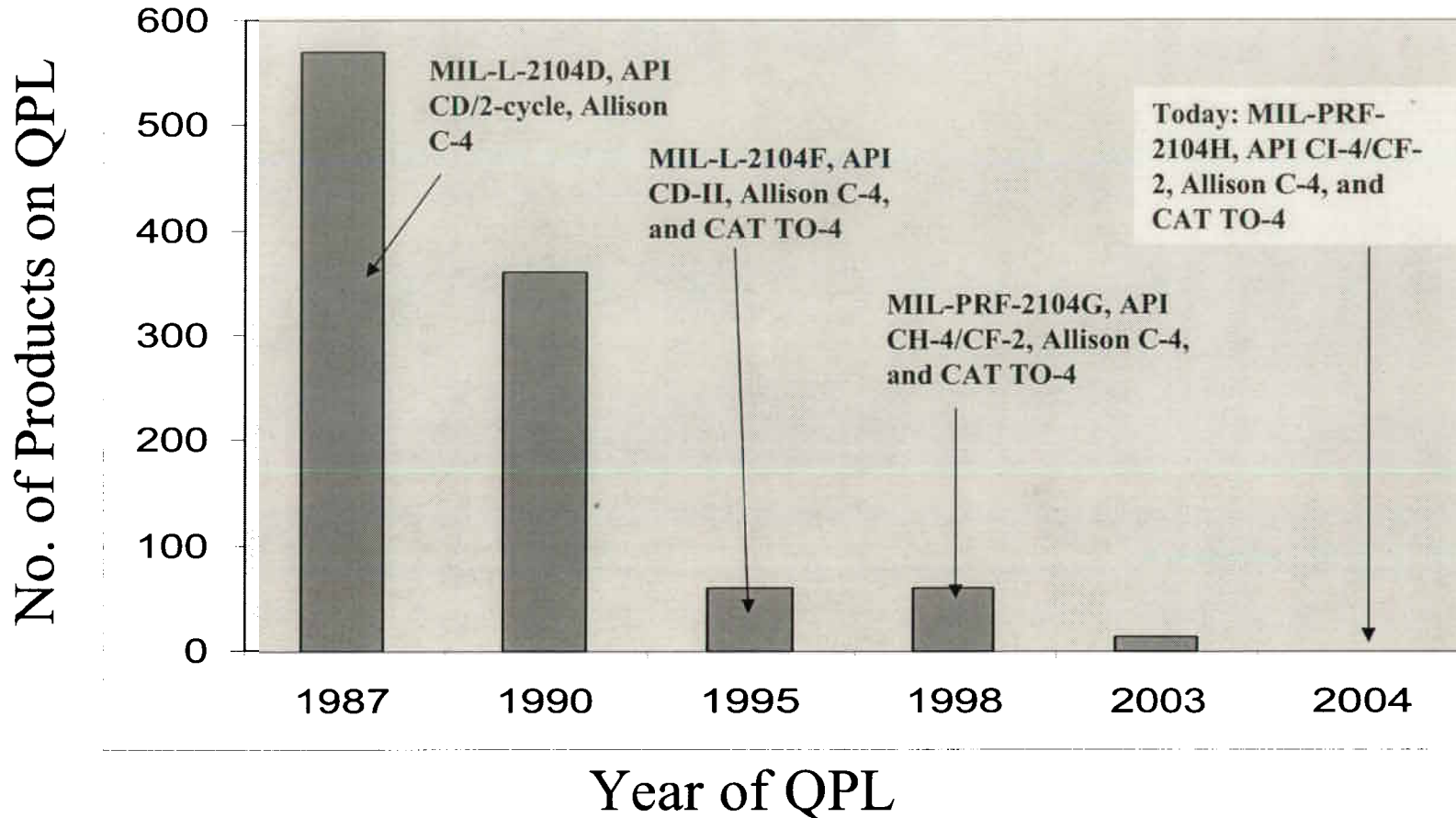

## Why is this happening? Several reasons:

- Reduction directly related to oil change interval issue associated with emission standards
- **Engine test costs have increased dramatically with each new API performance category (i.e. API CG-4, CH-4, CI-4....CJ-4)**
  - From 1998 cost of 200K per oil to 2004 cost of 400K per oil
- Combined engine and transmission performance are critical for reducing military logistics but more expensive - transmission test costs addition \$20K
  - ex. 2003 sample: M1, M2, and M915 (Allison Transmissions)
- Designing a dual engine-transmission lubricant is technically challenging and required formulators incur additional R&D expense
- **Lubricant formulators do not receive enough return on investment to justify the high test and R&D costs required to develop and produce military products**
  - Military does not contribute to testing cost

## Impact of Emission Standards on Military Heavy-Duty Diesel Engine/Transmission Oils (E/TO) – Performance concerns

- US Market Drivers for lubricants
  - Ultra-low-sulfur fuels (ULSF)
  - Compatibility with pollution prevention devices
- Some additive technologies proven to work well with higher sulfur fuels will not be allowed in the future
  - Additives with phosphorus and ZDDP (zinc dialkyl dithiophosphate)
  - Due to ‘poisoning’ of pollution devices
- Military exposure to high sulfur fuels raises concerns regarding engine protection with lubricant technology developed around ULSF
  - Concerns to Logistic and Maintainability
- Unknown impact of future engine oils on transmission performance
  - No commercial interest.

# Solution Pathways – Short Term to 2002/2004 Heavy-Duty On-Road Emission Standards

- EGR Engines
  - Issues: increased heat rejection and system volume, fuel and lubricant compatibility
  - Solution: employ EPA granted waiver, remove EGR system, recalibration of engine to meet military performance demands
  
- Non-EGR Engines
  - Issue: JP-8 compatibility
  - Solution: ensure JP-8 compatibility with engine system and compliance with military performance demands

## Solution Pathways – Long Term to 2007/2010 Heavy-Duty On-Road Emission Standards

- All engine systems heading toward some type of aftertreatment system with advanced combustion and closed loop control
  - NOx trap, catalyzed filters (CDPF/DOC), urea or fuel based SCR
  - HCCI, PCCI, and other more 'homogeneous combustion modes'
  - LTC : low temperature combustion for light loads, possible regeneration strategy
  - Heavy use of cooled EGR (~50% heat rejection increase vs. MY 1998)
    - possible low pressure cooled EGR in some cases
  - Exhaust sensors for temperature(s), pressure(s), NOx concentration, O<sub>2</sub> concentration
    - Closed loop control package for monitoring and regenerating aftertreatment devices
  - Commercial diesel fuel properties may require tighter combustion related property specifications for advanced combustion system operating modes



## Solution Pathways – Long Term to 2007/2010 Heavy-Duty On-Road Emission Standards

- Engine systems must be modified to meet military requirements
  - Use of blanket waiver for MY 2007+ engine systems
  - Removal of EGR system
  - Removal of aftertreatment devices
  - Recalibration
  - Ensure high sulfur fuel tolerant and oil compatible components



# THANKS!



**PETE'S NEW ENVIRONMENTALLY  
FRIENDLY FAMILY VEHICLE**