

AFRL-RX-TY-TP-2008-4550

POSTPRINT



ARFF ULTRA HIGH PRESSURE FIRE FIGHTING SYSTEMS (BRIEFING CHARTS)

Michael J. McDonald

**Applied Research Associates
PO Box 40128
Tyndall Air Force Base, FL 32403**

APRIL 2008

**Distribution Statement A:
Approved for public release; distribution unlimited.**

**Presented at the International Fire World Conference held in Beaumont, Texas,
28 April 2008.**

**AIRBASE TECHNOLOGIES DIVISION
MATERIALS AND MANUFACTURING DIRECTORATE
AIR FORCE RESEARCH LABORATORY
AIR FORCE MATERIEL COMMAND
139 BARNES DRIVE, SUITE 2
TYNDALL AIR FORCE BASE, FL 32403-5323**

REPORT DOCUMENTATION PAGE

Form Approved
OMB No. 0704-0188

The public reporting burden for this collection of information is estimated to average 1 hour per response, including the time for reviewing instructions, searching existing data sources, gathering and maintaining the data needed, and completing and reviewing the collection of information. Send comments regarding this burden estimate or any other aspect of this collection of information, including suggestions for reducing the burden, to Department of Defense, Washington Headquarters Services, Directorate for Information Operations and Reports (0704-0188), 1215 Jefferson Davis Highway, Suite 1204, Arlington, VA 22202-4302. Respondents should be aware that notwithstanding any other provision of law, no person shall be subject to any penalty for failing to comply with a collection of information if it does not display a currently valid OMB control number.
PLEASE DO NOT RETURN YOUR FORM TO THE ABOVE ADDRESS.

1. REPORT DATE (DD-MM-YYYY) 18-APR-2008	2. REPORT TYPE Conference Presentation POSTPRINT	3. DATES COVERED (From - To) 03-SEP-2002 - 21-APR-2008
--	---	---

4. TITLE AND SUBTITLE Aircraft Rescue Fire Fighting (ARFF) Ultra High Pressure Fire Fighting Systems (BRIEFING CHARTS)	5a. CONTRACT NUMBER FA4819-07-D-0001
	5b. GRANT NUMBER
	5c. PROGRAM ELEMENT NUMBER 62102F

6. AUTHOR(S) McDonald, Michael J.	5d. PROJECT NUMBER 4915
	5e. TASK NUMBER D1
	5f. WORK UNIT NUMBER 4915D11D

7. PERFORMING ORGANIZATION NAME(S) AND ADDRESS(ES) Applied Research Associates P.O. Box 40128 Tyndall Air Force Base, FL 32403	8. PERFORMING ORGANIZATION REPORT NUMBER
---	--

9. SPONSORING/MONITORING AGENCY NAME(S) AND ADDRESS(ES) Air Force Research Laboratory Materials and Manufacturing Directorate 139 Barnes Drive, Suite 2 Tyndall Air Force Base, FL 32403-5323	10. SPONSOR/MONITOR'S ACRONYM(S) AFRL/RXQD
	11. SPONSOR/MONITOR'S REPORT NUMBER(S) AFRL-RX-TY-TP-2008-4550

12. DISTRIBUTION/AVAILABILITY STATEMENT
Distribution Statement A: Approved for public release; distribution unlimited.

13. SUPPLEMENTARY NOTES
Ref AFRL/RXQ Public Affairs Case Number 08-118. Document contains color images. Presented at the International Fire World Conference in Beaumont, Texas on 28 April 2008.

14. ABSTRACT
The Air Force Research Laboratory has developed Ultra High Pressure (UHP) fire fighting as a method to reduce the amount of agent and extinguishment time required for fuel fires. Initial work was conducted on a 14 gpm system, but has been scaled up to 300 gpm. The effort included large scale experiments to demonstrate an overall reduction of agent usage to 28% of the amount required using conventional technology. UHP fire fighting is now fully developed and five trucks are being deployed to Air Force fire fighters for familiarization and operational verification. The first production buy is expected to occur in 2010.

15. SUBJECT TERMS
Ultra High Pressure Fire Fighting, Aircraft Rescue Fire Fighting (ARFF)

16. SECURITY CLASSIFICATION OF:			17. LIMITATION OF ABSTRACT SAR	18. NUMBER OF PAGES 29	19a. NAME OF RESPONSIBLE PERSON Virgil Carr
a. REPORT U	b. ABSTRACT U	c. THIS PAGE U			19b. TELEPHONE NUMBER (Include area code) 850-283-3744



AFRL/RXQD Fire Research Group



ARFF Ultra High Pressure Fire Fighting Systems

**Michael J. McDonald, PE
Applied Research Associates**

**Airbase Technologies Division
Tyndall Air Force Base, Florida**





Overview



- AFRL Fire Research Group: Who we are and what we do
- Partnerships
- Fire Research Goals



Fire Research Group



- **Mr. Virgil Carr:** Fire Research Program Manager
- **Dr. Pat Sullivan:** Environmental Research Engineer
- **2nd Lt. Eric DeGuzman:** Project Officer
- **Mr. Steven Wells:** Contract Group Leader
- **Dr. Doug Dierdorf:** Chief Scientist and Fire Chemistry
- **Dr. Mark Enlow:** Research Chemist
- **Ms. Jennifer Kalberer:** Environmental Engineer and Technical Writing
- **Mr. John Hawk:** Mechanical Engineer and Munitions Fire Protection
- **Mr. Ramon Sellers:** Mechanical Engineer
- **Mr. Parren Burnette:** Mechanical Engineer
- **Mr. Kris Cozart:** Mechanical Engineer
- **Mr. Mike McDonald:** Mechanical Engineer
- **Ms. Kim Barrett:** FAA Project Officer and Engineering Assistant
- **Mr. Richard Campbell:** Chemist
- **Mr. Chris Menchini:** Mechanical Engineer
- **Mr. Bill Fischer:** Live Fire Operations Leader and Fire Technician
- **Mr. Al Savejs:** Fire Technician
- **Mr. Rick Brill:** Fire Technician
- **Ms. Kathy Latza:** Administrative Support Staff
- **Ms. Peggy Allen:** Environment, Safety and Records Management



Mission & Objectives



- Conduct Exploratory and Advanced Research in Fire Fighting and Rescue Technologies
- Develop Improved:
 - Suppression/mitigation agents
 - Agent application techniques and
 - Specialized equipment
- Required to:
 - Support Air Force firefighters
 - Enhance deployed operations and
 - Counter new or evolving fire threats to DoD/Federal weapons systems and operations



Customers and Collaborations

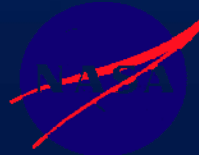

Blount Brass
Manufacturing





Fire Research Goals



- Provide breakthrough fire fighting technologies to the warfighter
- Maintain worldwide leadership in aircraft rescue and fire fighting science
- Transfer Air Force fire fighting technologies to meet needs of civil aviation
- Leverage unique facilities and capabilities to control R&D costs
 - Support DoD and civilian operational requirements
 - Provide one-of-a-kind fire protection evaluations
 - Provide experiments benefiting military and civilian firefighter needs at minimum cost
- Provide capabilities to protect future weapons systems
 - Identify fire hazards of new materials
 - Develop technologies to mitigate these hazards



UHP Fire Fighting Program Objectives



- Develop Requirements for a Deployable Fleet of Next Generation UHP-capable ARFF Vehicles
- Reduce Agent Requirements
- Reduce Fire Equipment Size
- Improve Ease of Operation
- Gain Operational Experience with Air Force Firefighters

Measured Fire Fighting Effectiveness (gal/ft²)

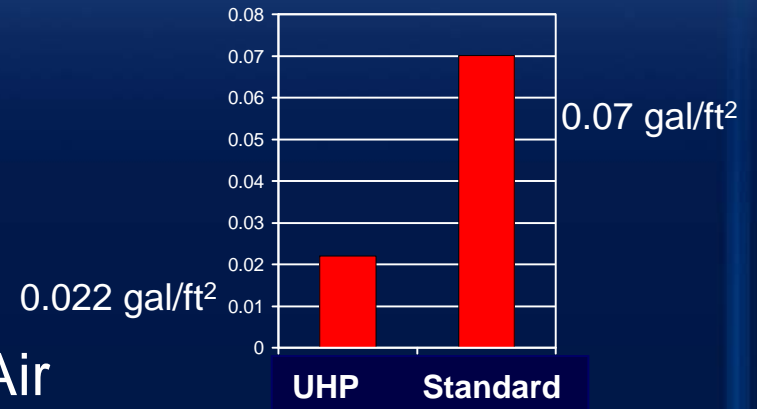

Standard P-19

VS.

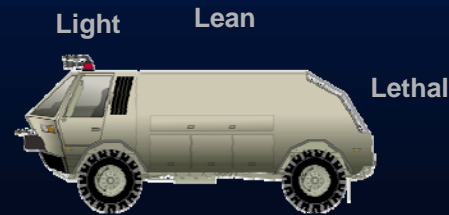

Future ARFF Vehicle



UHP History



Oct 2002: 14 gpm FRE Fire



Mar 2003: Fielded 3 FRE in Iraq



Apr 2004: 100 gpm UHP Skid



Aug 2004: 200 gpm UHP T1500





Initial Testing of the FRE



- John Deere Military Gator
- Rosenbauer Ultra High Pressure System
 - 1500 psi (100 Bar)
 - 14 gpm (53 l/min)
 - Variable Stream – Variable Aspiration Nozzle
- Unprecedented Firefighting Capability
 - 700 ft² Pool Fire JP-8 – 23 seconds/4 gallons 3% AFFF/Water
 - F 100 3 Dimensional Fire (new Halon 3D Standard) – 20 seconds/3.3 gallons
- Demonstrated Need to
 - Increase pump and engine capacity
 - Marry to Air Drop Certified Platform





FRE-FIRE VEHICLE RESULTS



- 85% reduction in water
- 50% reduction in fire fighting effort
- 4 fold increase in hose length





FRE Fire Video





AIR DROP CERTIFIED



- Certified for Air Drop (3X from 1500 ft.), fully operational
- Also tested on Polaris Chassis (Alternate)
- Lab FRE-Fire efforts end





FEET Test Results



Extinguishing Rate

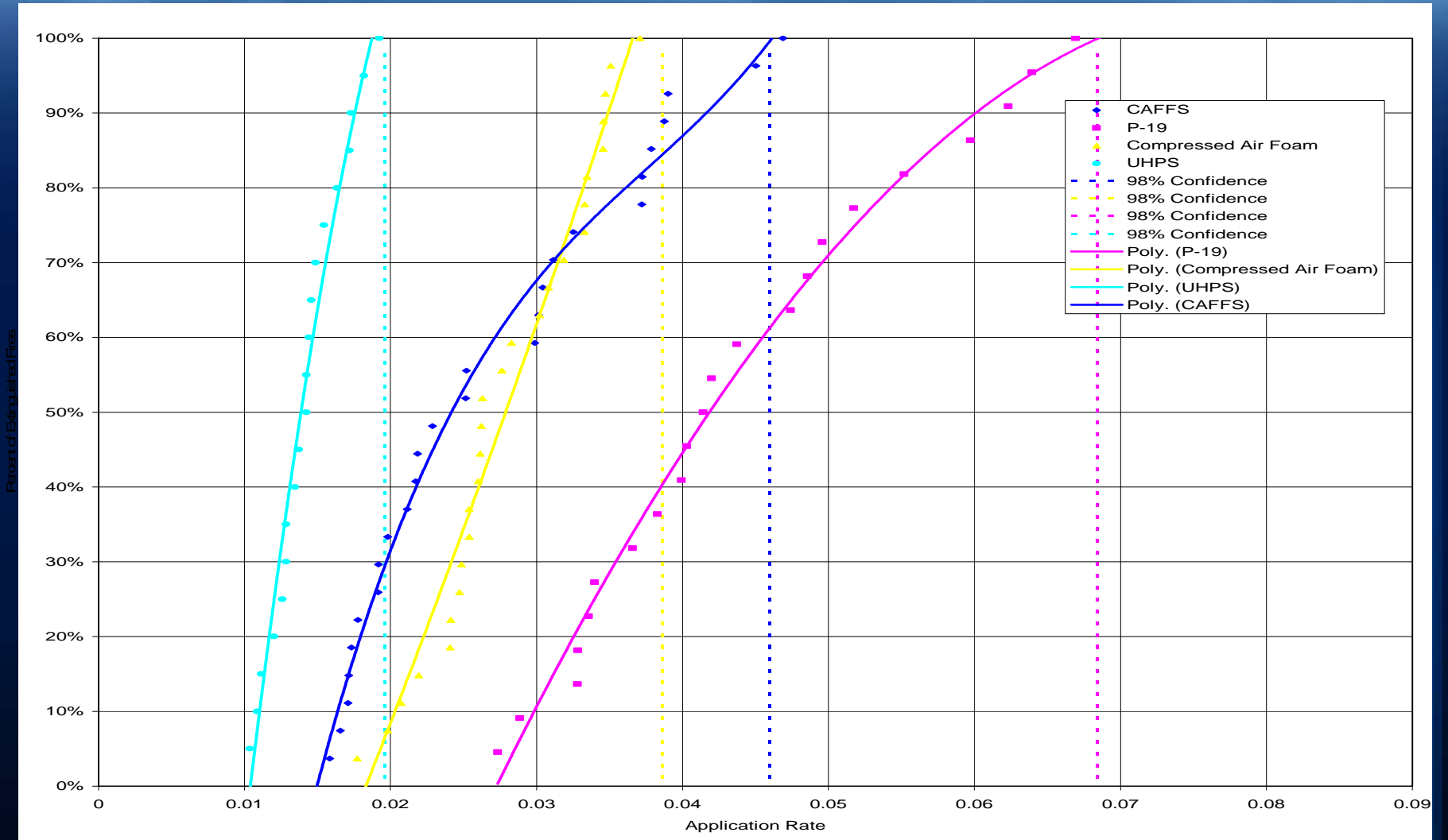

Percent of Extinguished Fires



Prototype 200 gpm UHP Crash Vehicle



- **Response to cargo aircraft engine fire**
- **Pure water UHP alone would not extinguish fire**
- **Added gaseous agent to achieve extinguishment**

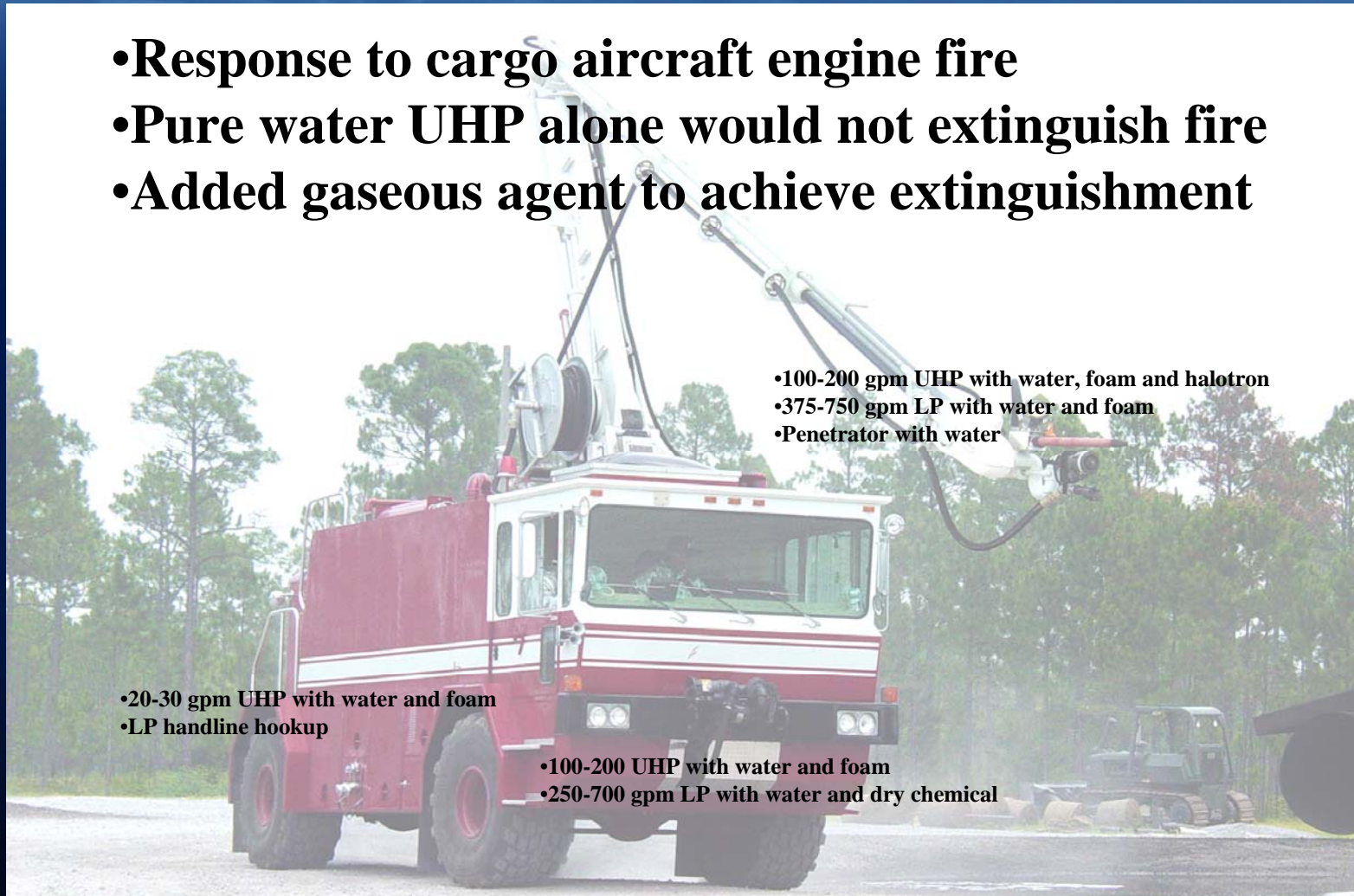



Prototype 300 gpm UHP P-19 Design

Agent Delivery Systems



- Ultra high pressure (UHP)
 - 300 GPM bumper turret
 - 30 GPM 150 ft handline
- Compressed air foam (CAF)
 - 300 GPM bumper turret
 - 45 GPM 100 ft handline
- Dry chemical (PKP)
 - 7 pps bumper turret
 - 5 pps 100 ft handline

UHP P-19



UHP P-19 Schematic

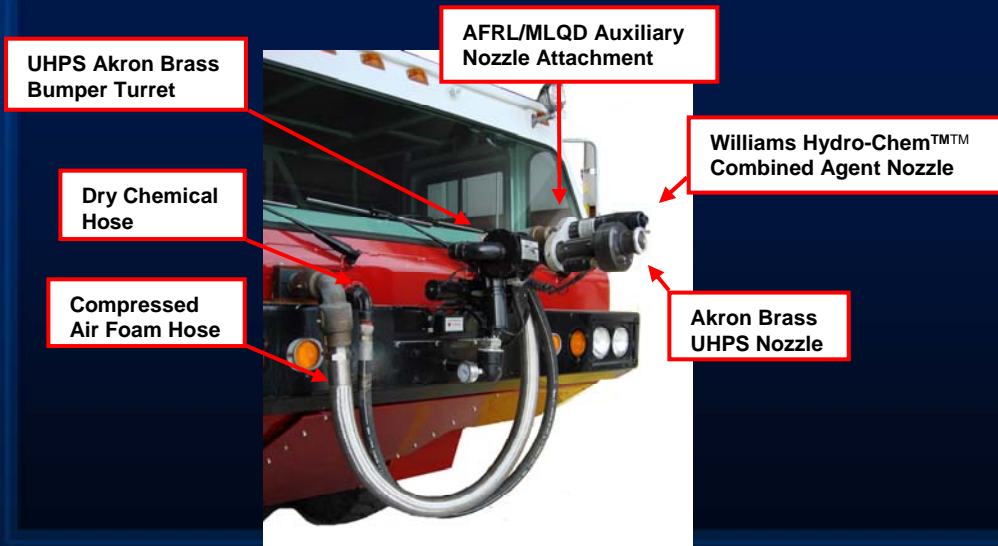
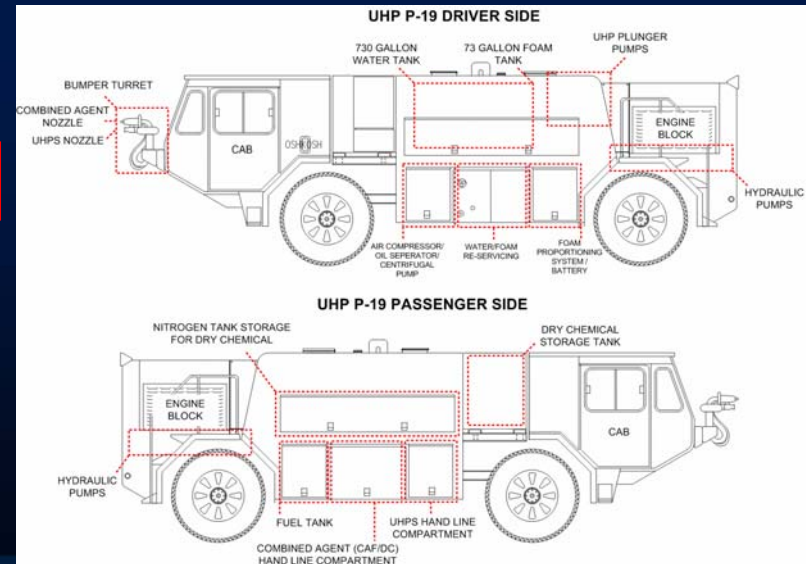



Design Summary



Distinguishing Features

- Hydraulically Controlled Fire Fighting Pumps
 - 3 - 100 GPM Reciprocating UHP Plunger Pumps totaling 300 GPM
 - 300 GPM Combination Centrifugal Pump/Air Compressor
 - UHP Foam Proportioning System
- 730 Gallon Water/73 Gallon Foam Combination Tank
- Removal of Roof Turret
- Prototype UHP Nozzle and Turret Design

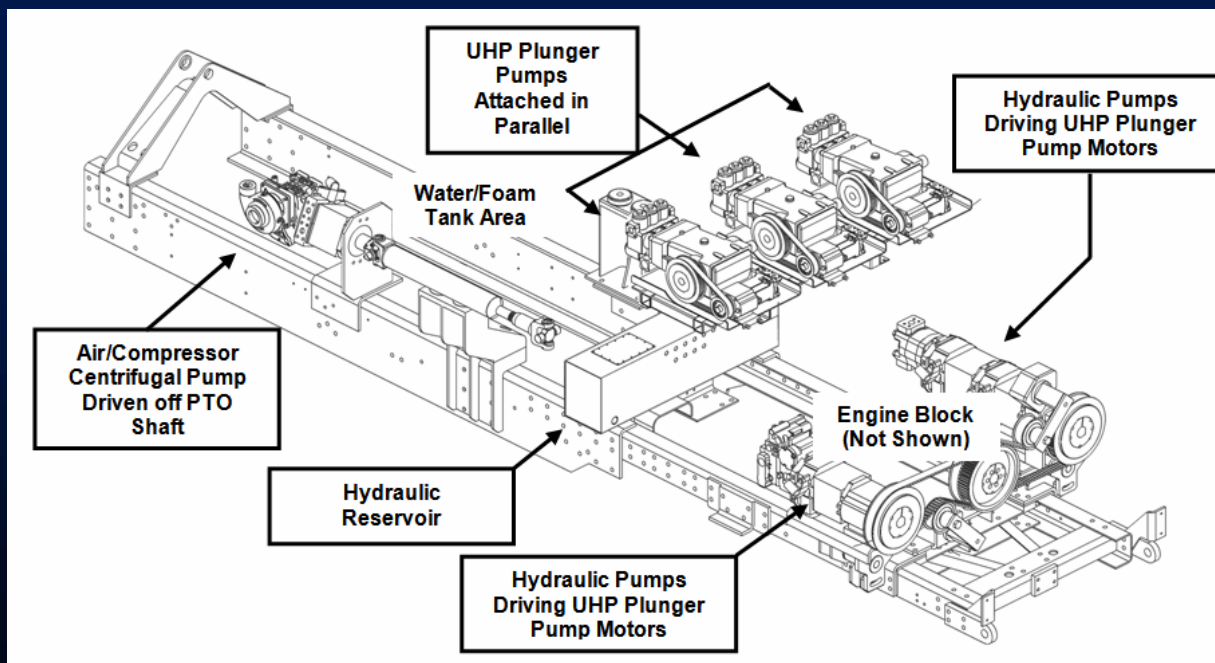



Design Summary

Distinguishing Features

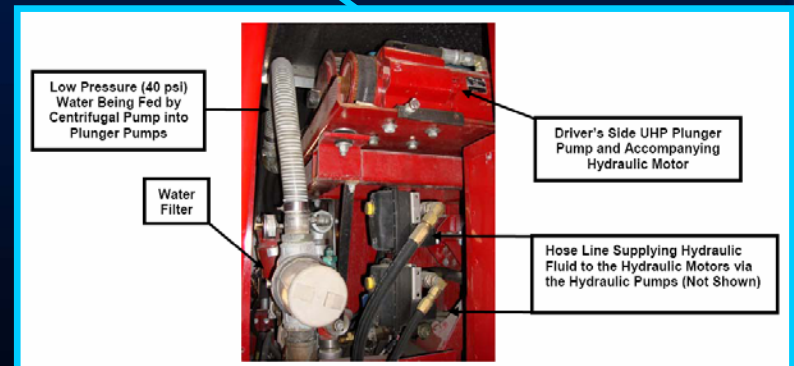
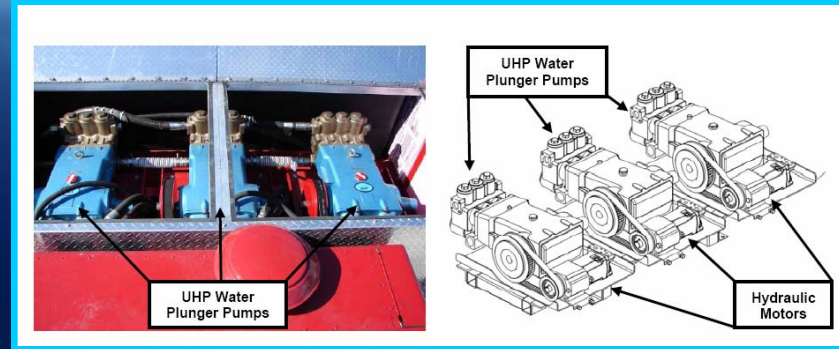
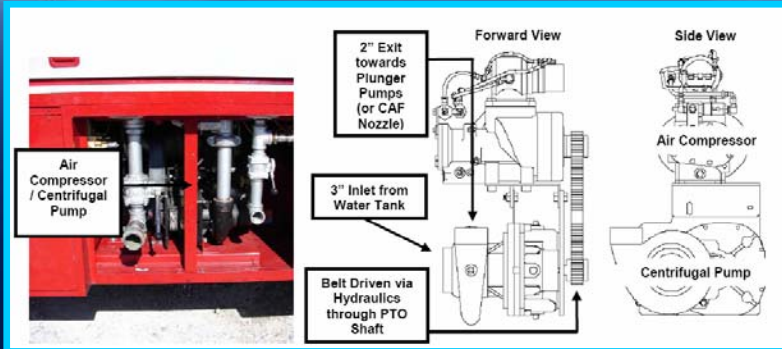



Nozzle Performance Evaluation

UHP Nozzle Flow Characterization



- UHP turret nozzles from 2 suppliers performed comparably
- Improved handline performance on UHP P-19 over smaller scale UHP vehicles

UHP Turret Nozzle Comparison

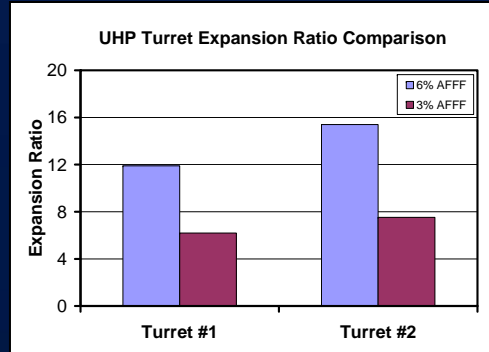
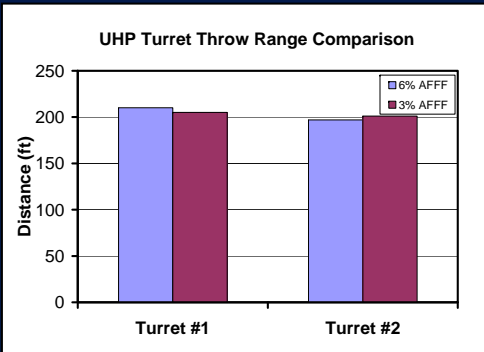

UHP Hand Line Nozzle Comparison

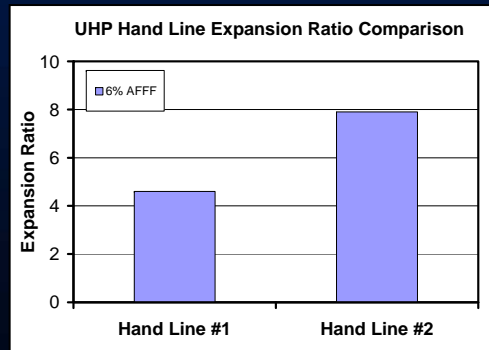
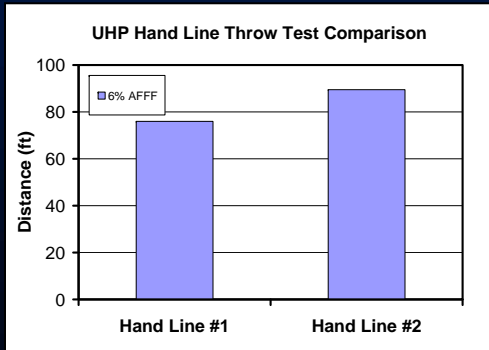

UHP 300 GPM UHP Tested Nozzles & Turrets



Elkhart Brass



Akron Brass

UHP 30 GPM UHP Tested Handlines



Akron Brass



AFRL/RXQD Design





Existing UHP P-19 Pump System



3 Piston Pumps



- + 4 Hydraulic Pumps
- + 4 Hydraulic Motors
- + 4 PTOs
- + 1 Centrifugal Pump
- + 30 gal Hydraulic Tank

EQUALS
A LOT OF SPACE
&
A LOT OF POWER



New UHP P-19 Pump System



1 Centrifugal Pump + 1 PTO =

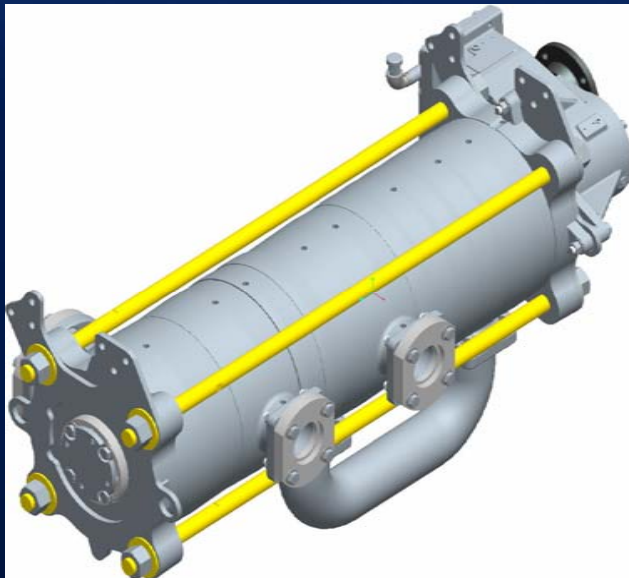

- Reduced Size
- Reduced Weight
- More space for agent
- Simplified operation and maintenance

PERMITS ORIGINAL 1000 GALLON CAPABILITY



300 gpm UHP Centrifugal Pump



- Designed by WS Darley and Oshkosh Corp.
- Provides 300 gpm at 1300 psi
- Eliminates all hydraulic drives used in the previous UHP-P19
- Reduces weight, size, cost and complexity of components
- Makes a smaller, lighter fire truck with increased water capacity

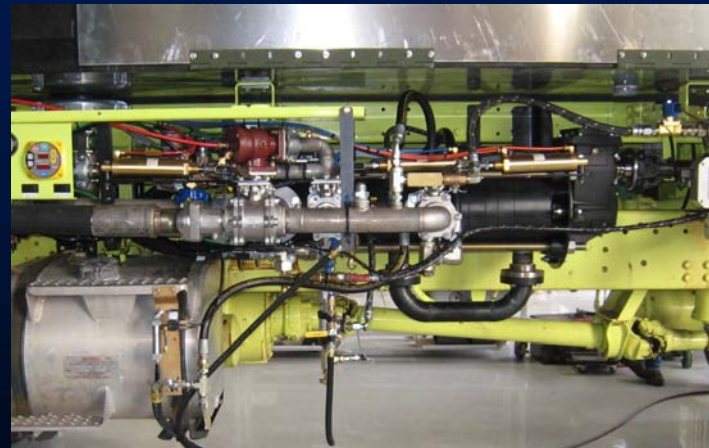



UHP P-19 Modification Overview



- Maj. Gen Eulberg approved \$2.5M to modify five P-19's with UHP technology
- Oshkosh Corp. started this program on August 6, 2007
- Five bases with hydrocarbon pits chosen for program
 - Tyndall AFB, FL
 - Dyess, TX
 - Ellsworth, SD
 - Mountain Home, ID
 - Davis Monthan, AZ
- 25 fires per base



Safety Impact Study



- UHP turret nozzle impact measurements are important for operational safety recommendations
- Total dynamic pressure reduces significantly as the jet spreads further from the nozzle
- Total risk of injury is no greater than standard fire fighting delivery methods

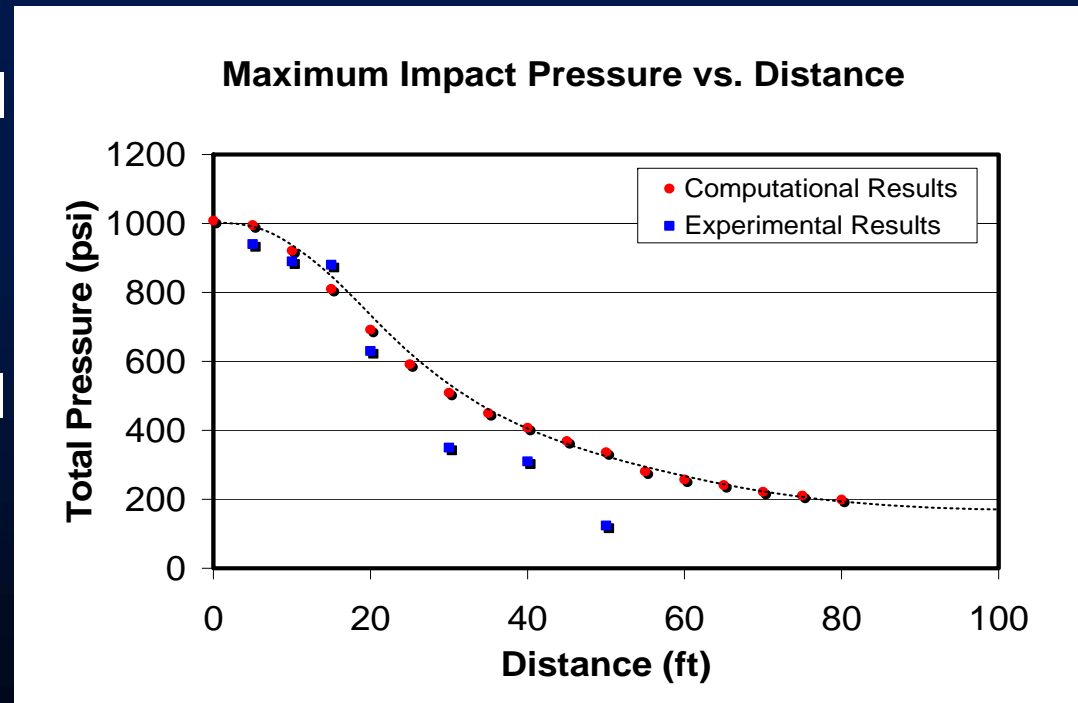
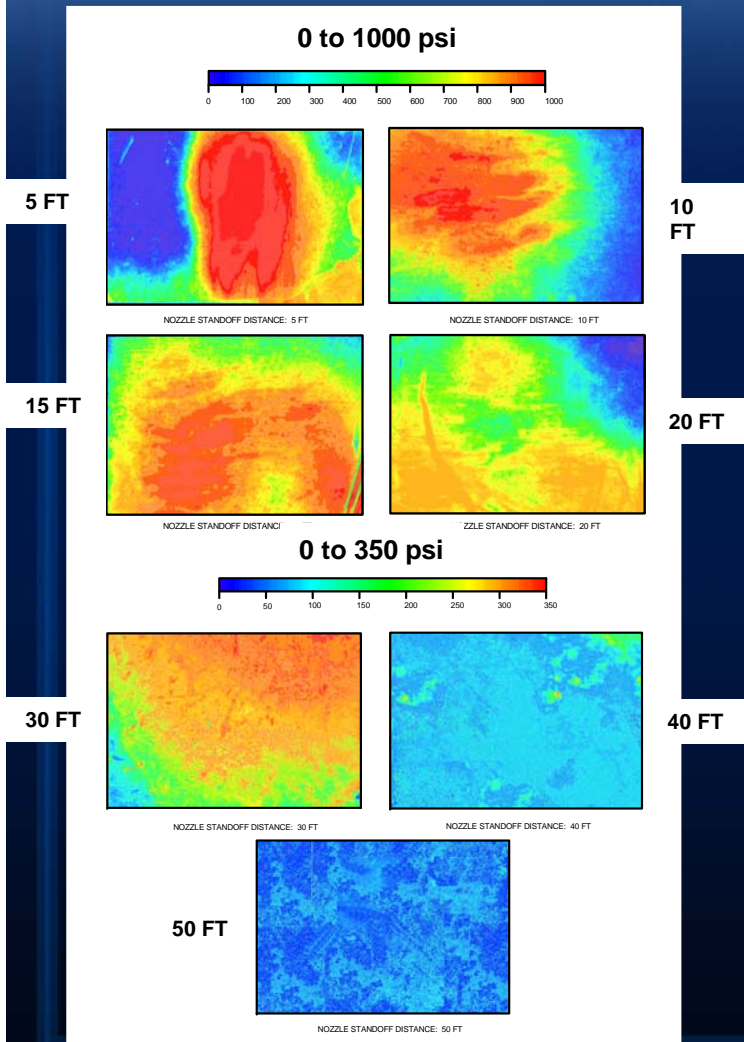



HMA All-Terrain Vehicle



- 60 gpm UHP Turret
 - 30 gpm Handline
 - 300 Gallon Water Tank
 - 1100-1500 psi Operational Pressure
 - Draft from Alternate Water Source
-
- Advanced, all-terrain, multipurpose fire/rescue vehicle
 - Incorporates the latest technology in ultra high pressure (UHP) water, infrared vision, navigation/tracking/communication systems, and on/off road mobility
 - Diverse applications from wildland to Aircraft Rescue Fire Fighting
 - New platform for evaluating UHP technologies





Future Developments



- Wild land fire fighting
 - HMA Vehicle
 - Cannon AFB grass fires
- Structural Applications
 - Rosenbauer Systems





Conclusions



- AFRL clearly demonstrated improved fire fighting efficiency through scaled UHP technologies
- Prototype UHP P-19 demonstrated UHP, CAF and combined agent firefighting using commercially available and R&D technology
- UHP nozzle throw tests demonstrated exceptional reach
- UHP foam quality exceeds current standards
- Discharge UHP pressure will not break or penetrate skin
- Next-Gen UHP P-19 will exceed current design standards
- AFRL initiating new UHP technologies through HMA platform
- Initial UHP trucks to be awarded in 2010