

Report Documentation Page

Form Approved
OMB No. 0704-0188

Public reporting burden for the collection of information is estimated to average 1 hour per response, including the time for reviewing instructions, searching existing data sources, gathering and maintaining the data needed, and completing and reviewing the collection of information. Send comments regarding this burden estimate or any other aspect of this collection of information, including suggestions for reducing this burden, to Washington Headquarters Services, Directorate for Information Operations and Reports, 1215 Jefferson Davis Highway, Suite 1204, Arlington VA 22202-4302. Respondents should be aware that notwithstanding any other provision of law, no person shall be subject to a penalty for failing to comply with a collection of information if it does not display a currently valid OMB control number.

| | | | | | |
|--|---|---|---|------------------------------------|------------------------------------|
| 1. REPORT DATE 22 APR 2004 | 2. REPORT TYPE Technical, Success Story | 3. DATES COVERED 15-03-2004 to 22-04-2004 | | | |
| 4. TITLE AND SUBTITLE Titanium Socket for 120 mm Mortar Base | | 5a. CONTRACT NUMBER | | | |
| | | 5b. GRANT NUMBER | | | |
| | | 5c. PROGRAM ELEMENT NUMBER | | | |
| 6. AUTHOR(S) | | 5d. PROJECT NUMBER 04-0031-02 | | | |
| | | 5e. TASK NUMBER | | | |
| | | 5f. WORK UNIT NUMBER | | | |
| 7. PERFORMING ORGANIZATION NAME(S) AND ADDRESS(ES) National Center for Defense Manufacturing & Machining,1600 Technology Way,Latrobe,PA,15650 | | 8. PERFORMING ORGANIZATION REPORT NUMBER | | | |
| 9. SPONSORING/MONITORING AGENCY NAME(S) AND ADDRESS(ES) | | 10. SPONSOR/MONITOR'S ACRONYM(S) | | | |
| | | 11. SPONSOR/MONITOR'S REPORT NUMBER(S) | | | |
| 12. DISTRIBUTION/AVAILABILITY STATEMENT Approved for public release; distribution unlimited | | | | | |
| 13. SUPPLEMENTARY NOTES | | | | | |
| 14. ABSTRACT The U.S. Army's Armament Research, Development and Engineering Center (ARDEC) at Picatinny Arsenal in Rockaway Township, N.J., was commissioned to reduce the weight of the base for the 120mm mortar. Their efforts included replacing an approximately 5.5"-diameter steel base support with one made of titanium 6AL-4V. Titanium weighs 45 percent less than steel, is stronger and more resilient, and doesn't rust. However, its unique properties also make it difficult to machine productively. ARDEC was spending excessive time turning a profile of a ball socket into the component that supports the mortar tube. ARDEC requested the assistance of the National Center for Defense Manufacturing & Machining (NCDMM) to reduce the machining time and, thereby, the cost of the process. | | | | | |
| 15. SUBJECT TERMS National Center for Defense Manufacturing & Machining; NCDMM; U.S. Army's Armament Research, Development and Engineering Center; ARDEC; Success Stories; Picatinny Arsenal | | | | | |
| 16. SECURITY CLASSIFICATION OF: | | | 17. LIMITATION OF ABSTRACT 1 | 18. NUMBER OF PAGES 1 | 19a. NAME OF RESPONSIBLE PERSON |
| a. REPORT unclassified | b. ABSTRACT unclassified | c. THIS PAGE unclassified | | | |

Titanium Socket for 120 mm Mortar Base

NCDMM Project No. 04-0031-02

PROBLEM / OBJECTIVE

The U.S. Army's Armament Research, Development and Engineering Center (ARDEC) at Picatinny Arsenal in Rockaway Township, N.J., was commissioned to reduce the weight of the base for the 120mm mortar. Their efforts included replacing an approximately 5.5"-diameter steel base support with one made of titanium 6AL-4V. Titanium weighs 45 percent less than steel, is stronger and more resilient, and doesn't rust. However, its unique properties also make it difficult to machine productively. ARDEC was spending excessive time turning a profile of a ball socket into the component that supports the mortar tube. ARDEC requested the assistance of the National Center for Defense Manufacturing & Machining (NCDMM) to reduce the machining time and, thereby, the cost of the process.

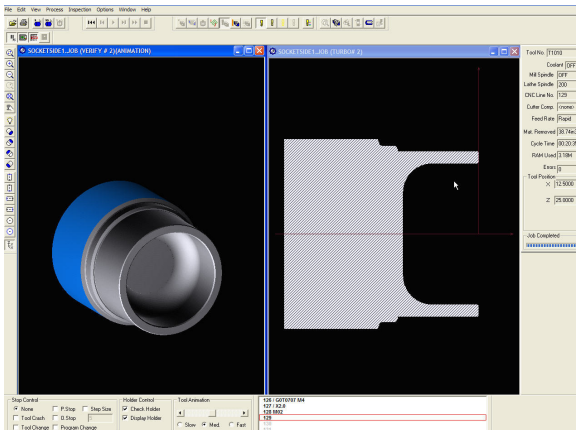

NCDMM created a "proof-of-concept" simulation using Predator verification software supplied by software provider COM 1, an NCDMM alliance partner. The process then was proved out on ARDEC's CNC lathe at Picatinny Arsenal.

ACCOMPLISHMENTS / PAYOFF

Process Improvement

NCDMM analyzed the operation and recommended new tooling for both turning and drilling aspects of the base machining process. High performance PVD-coated carbide cutting insert material was introduced for the profile turning operation, and upgraded indexable insert drills were employed for roughing out the bore. Both turning speed and depth of cut increased, producing a metal removal rate ten

times greater than achieved previously. Drilling speeds also increased by 40 percent.

Implementation and Technology Transfer

ARDEC implemented NCDMM recommendations on its existing CNC lathe. Metal removal rate in turning increased from .03 cubic inches per minute (in³/min) to .3 in³/min. High-performance drilling insert technology permitted drilling speed to be raised from 90 surface feet per minute (sfm) to over 125 sfm. Feed rate was increased proportionately to balance chip load. Overall, machining time for the socket dropped from 16 hours to 1 hour 45 minutes.

Expected Benefits

In summary, implementation produced:

- An 800 percent increase in turning and drilling productivity, representing an 89 percent decrease in machining time. No additional capital investment was required, because existing equipment was employed
- A lighter, stronger, corrosion-resistant component produced more efficiently

At Picatinny's current burden rate, savings in machining time alone amounted to \$855.00 per socket. Over the entire intended production run of 600 lightweight mortar bases, machine time savings totaled \$513,000. Less quantifiable but nevertheless real further savings include reduced expenditure of energy in transporting the mortar bases. Most importantly, the lighter weapons will enhance the responsiveness of the units that use them. The first forty of the improved mortar bases are scheduled to be fielded in Iraq in July 2004.

TIME LINE / MILESTONE

Start Date March 04
End Date April 04

PROJECT FUNDING

NCDMM funding \$8.5K

PARTICIPANTS

ARDEC/ Picatinny Arsenal
NCDMM
Com 1 Information Technologies, Inc.
Kennametal Inc.

For additional information concerning this project, contact the NCDMM at www.ncdmm.org