

UNCLASSIFIED

AR-004-854

DEPARTMENT OF DEFENCE  
DEFENCE SCIENCE AND TECHNOLOGY ORGANISATION  
ELECTRONICS RESEARCH LABORATORY

TECHNICAL MEMORANDUM

ERL-0385-TM

A LABORATORY FACILITY FOR MEASURING SOLAR REFLECTIONS FROM  
MODEL AIRCRAFT

R.J. Oermann

S U M M A R Y

A laboratory facility has been developed to simulate solar reflections from military aircraft. Scale models are placed in a mount which enables orientation in any chosen attitude. A fixed infrared source is collimated to simulate the sun and a mobile detector accepts reflected radiation in the 1.8  $\mu\text{m}$  to 2.5  $\mu\text{m}$  waveband.

A computer program generates the relevant parameters necessary to describe the aircraft's attitude in the frame of reference which includes both the observer and the sun. A group of such parameters enables an entire overhead pass of an aircraft to be simulated.

The resultant relative reflectance plot gives an indication of the radiance from an aircraft primarily due to solar reflection.



---

POSTAL ADDRESS: Director, Electronics Research Laboratory,  
Box 2151, GPO, Adelaide, South Australia, 5001.

---

UNCLASSIFIED

## TABLE OF CONTENTS

	Page
1. INTRODUCTION	1
2. EQUIPMENT	1
2.1 General	1
2.2 Infrared source	1
2.3 Model mounting apparatus	1
2.4 Infrared detector	2
3. MATHEMATICAL ANALYSIS	2
3.1 General	2
3.2 Pass determination	2
3.3 Set up data	3
3.3.1 Axis systems	3
3.3.2 Angle determination for laboratory simulation	4
3.3.3 Application to the model mounting	5
4. EXPERIMENTAL METHOD	5
4.1 Sample set up of data	5
4.2 Experimental procedure	5
4.3 Sample set of results	6
5. CONCLUSIONS	6
REFERENCES	7

## LIST OF APPENDICES

I DERIVATION OF SETTING UP ANGLES FOR MODEL MOUNTING APPARATUS	9
II DETERMINATION OF OVERHEAD PASS POSITION VECTORS	15
III DETERMINATION OF SET UP ANGLES FOR THE MODEL MOUNTING APPARATUS	18

## LIST OF FIGURES

1. General assembly
2. The model mounting apparatus
3. SAD plane and the aircraft axis system in the final orientation
4. Aircraft rotations on the model mounting apparatus

5. Solar reflectance plot

## 1. INTRODUCTION

As part of the evaluation of CM to anti-air IR guided weapons it is necessary to measure the magnitude of the component of the aircraft's infrared signature that is due to reflections of solar radiation. This is important because infrared-homing missiles may home onto solar reflections as well as onto the heat from hot engine components.

Measurements of the solar reflection from real aircraft do not necessarily provide a useful data bank, in the first instance, because of the variation of some illumination parameters. Consequently a simulator has been built to provide data on solar reflections, which can be used as a data base for the research of techniques whereby solar reflection can be eliminated or reduced.

The simulator enables a scale model of an aircraft to be held in the correct orientations as viewed by an observer on the ground, while maintaining the required angular relationships between the sun, aircraft and observer. A computer program produces sets of normalised position vectors of certain positions of the aircraft during its simulated trajectory. These, together with the azimuth and elevation of the sun (as viewed from the observer on the ground) are used as input-data to another program which calculates the four angles for each degree of freedom (and their corresponding senses of rotation) that can be set on the simulator. Each position of the aircraft in its trajectory must be set up individually.

## 2. EQUIPMENT

### 2.1 General

The apparatus consists of three main components: the infrared source to simulate solar radiation as near as practicable in both spectral and divergence characteristics; the model mounting apparatus that enables a scale model aircraft to be held in any required attitude; and an infrared radiometer mounted on an arm that can be rotated about the model mounting apparatus giving the fourth degree of freedom to the total apparatus.

### 2.2 Infrared source

A Nernst Glower is used as the source of infrared radiation, having an effective temperature (when operating) of about 2100°K. Its spectral characteristics are different from those of the sun, by a measureable amount in the relevant wavelength vicinity. The Nernst Glower's spectral distribution has a maximum at approximately 1.37  $\mu\text{m}$ , whereas the sun can be considered as a blackbody radiator whose spectral distribution has a maximum at approximately 0.5  $\mu\text{m}$ . The radiation from the Nernst Glower is brought to a pseudo focus, using an elliptical reflector, and is then passed through a 6 mm aperture placed at the focus of a reflecting collimator. This optical system simulates the divergence of the sun's radiation as viewed from earth.

### 2.3 Model mounting apparatus

The model is mounted on the end of a rotatable spindle, in the centre of a 1 m diameter aluminium ring. The ring is supported on its underside by two rollers that enable the entire ring to be rotated about its central axis. The supporting rollers are mounted on a platform that, besides containing scales for angular measurement, can itself be rotated about a vertical

axis. Adjusting each of the three angles enables orientation of the aircraft in any required attitude. These three rotations can each be set up to an accuracy of  $1^\circ$ . The main, moveable and upper parts of the mounting are illustrated in figure 2.

The scale model can be easily, yet accurately, removed and replaced on the end of the spindle, to enable reliable measurements of background radiation.

#### 2.4 Infrared detector

A radiometer (sensitive to radiation in the range 1.8 to 2.7  $\mu\text{m}$ , and having a spectral response similar to that of an SA-7 missile; see reference 1) is used as the detector. It collects infrared radiation through a reflecting collimator to simulate viewing at infinity. The dc voltage levels received from the radiometer are interpreted by using calibration data, together with detector spectral response and source spectral distribution, as the radiant intensity from all objects in the radiometer's field of view. By repeating the experiment in the absence of the scale model, infrared reflections from only the aircraft may be determined.

### 3. MATHEMATICAL ANALYSIS

#### 3.1 General

This apparatus has the facility to reproduce in the laboratory a view of an aircraft in the observer's frame of reference. Moreover the position of the sun is set in relation to the aircraft attitude and the observer. This is necessary for a study of solar reflections from aircraft. The system is specified in relation to the observer on the ground through six input parameters. They include the x, y and z components of a normalised position vector that defines the position of the aircraft in the observer's frame of reference (see Section 3.2), the azimuth and elevation of the sun again in relation to the observer's frame of reference, and the heading of the aircraft.

From these six pieces of information, for a given situation, the major piece of analysis (see Section 3.3) ultimately results in their transformation to four rotational angles that, when applied to the model mounting apparatus, reproduces the real situation.

A typical aircraft trajectory that could be described is a straight and level flight passing overhead. Here a sequence of position vectors, enabling a sequence of set ups of the model, on the model mounting apparatus, would illustrate, in a realistic way, the form in which an aircraft is observed as it passes overhead.

This mathematical analysis is therefore divided into two parts. Firstly, the method used to produce a set of position vectors corresponding to a certain overhead horizontal pass of an aircraft, and secondly, the use of these position vectors together with three other input parameters to produce the angular settings required for the model mounting apparatus.

#### 3.2 Pass determination

The result of the first calculation is a set of position vectors that describe the position of the aircraft in the observer's frame of reference. The frame of reference of the observer is described by an axis system E. This is an orthogonal axis system with the x-direction pointing North, the y-direction pointing East and the z-direction pointing vertically down.

The symbol E will be used as a subscript on vectors defined relative to the observer's axis system. Parameters for a given flight path are initially entered with reference to this axis system.

In order to specify a horizontal pass, the initial azimuth ( $Aa_E$ ) and elevation angle ( $Ae_E$ ) of the aircraft together with its heading (h) must be considered. The initial position is converted to the normalised position vector:

$$a_E = [\cos(Ae_E).\cos(Aa_E), \cos(Ae_E).\sin(Aa_E), -\sin(Ae_E)]$$

and the heading direction in degrees True North is converted to the direction vector:

$$(\cos(h), \sin(h), 0).$$

By suitable scaling of the direction vector and addition to the initial position vector, a set of position vectors that describes a horizontal pass overhead, can be produced.

A computer program has been developed that generates any number of position vectors for an input overhead pass and stores them in a file together with the heading that describes the pass. See Appendix II for guide to using this program.

### 3.3 Set up data

#### 3.3.1 Axis systems

Besides the E-axis system described in Section 3.2 another axis system is introduced which describes initial parameters relative to the aircraft's frame of reference. The orthogonal aircraft axis system (A) is defined with its x-axis pointing towards the front of the aircraft and the y-axis pointing in the direction of the starboard wing. The z-axis is thus vertically down.

In order to simplify the overall system a restriction is imposed that the aircraft is making a horizontal pass overhead with no roll. This enables the two axis systems to be related to each other by a simple rotation about their respective z-axes followed by a linear translation. The heading (h) of the aircraft in degrees True North gives the angle required for the rotation transformation defined by the rotational transformation matrix R where:

$$R = \begin{pmatrix} \cos (h) & \sin (h) & 0 \\ -\sin (h) & \cos (h) & 0 \\ 0 & 0 & 1 \end{pmatrix}$$

The vector ( $a_E$ ) from the observer to the aircraft defines the translation necessary to coincide the two axis systems.

All parameters required to describe a particular aircraft aspect are entered with reference to the E-axis system and must be transformed to the A-axis system. The vector from the observer to the aircraft ( $a_E$ ) in the observer's frame of reference (the E-axis system) can be transformed into another vector ( $d_A$ ) which describes the location of the detector from the aircraft in the A-axis system.

The vector from the aircraft to the detector ( $d_E$ ) in the E-axis system can be simply determined

$$d_E = -a_E$$

The vector  $d_E$  can now be transformed into the A-axis system using the rotational transformation matrix R.

$$d_A = R \cdot d_E$$

The azimuth and elevation of the sun in the E axis system ( $Sa_E$  and  $Se_E$  respectively) can be used to produce the vector from the detector to the sun in the E-axis system. In its normalised form this is found to be:

$$s_E = [\cos Se_E \cdot \cos Sa_E, \cos Se_E \cdot \sin Sa_E, -\sin Se_E]$$

This vector can be translated to the origin of the A-axis system without change and then transformed into the A-axis system using the matrix R.

$$s_A = R \cdot s_E$$

The heading of the aircraft in the A-axis system can be expressed as the vector  $[1,0,0]$ . The SAD plane is now defined as the plane containing the two vectors  $s_A$  and  $d_A$  and hence the origin of the A-axis system.

### 3.3.2 Angle determination for laboratory simulation

In the laboratory the infrared source is fixed and the detector is forced to rotate in a horizontal plane about the aircraft. A transformation, therefore, must be applied to the real situation and all vectors to make them relative to the plane containing the Source, Aircraft and Detector (hereinafter referred to as the SAD plane).

The four angles required to set up the model mounting apparatus must be extracted. The easiest angle to calculate first is the angle between the detector and the infrared source (see figures 3 and 4). This angle is actually  $\angle$ SAD and is thus:

$$a = \arccos (s_A \cdot d_A)$$

The remaining three angles to be evaluated (b, c and d) correspond to the ordered rotations of the aircraft about its z-axis, y'-axis and

x"-axis respectively. The model mounting apparatus enables these three rotations to occur without lateral translation of the model.

### 3.3.3 Application to the model mounting

The setting of angle a (the angle between the detector and infrared source) is accomplished by moving the detector, on its pedestal, around the model mounting apparatus. The remaining three angles need more careful and ordered setting. To initialise all scales to their starting position the ring of the model mounting apparatus is rotated about its centre until the spindle is horizontal. The model is then attached to the end of the spindle as shown in figure 2 and the spindle twisted to orient the aircraft correct side up and level. Finally the whole apparatus is rotated about its vertical axis until the aircraft is pointing at the infrared source. In this configuration all scales should read zero.

In this position, each of the three degrees of freedom correspond to rotations about each of the aircraft axes, and will remain so provided the correct order of rotation is observed. The first rotation is that of the whole apparatus, which is about the aircraft's z-axis. This rotation will swing the aircraft around to a position in the SAD plane immediately below its final pointing vector (see figure 4). The angle b is set from this rotation. Secondly, by revolving the actual ring, a rotation about the aircraft's y'-axis is performed and enables the angle c to be set. This rotation raises the aircraft out of the SAD plane so that its body coincides with the final pointing vector of the aircraft. Finally the twisting of the spindle rotates the aircraft about its x"-axis and enables the angle d to be set (see figure 4). The correct sense of rotation is determined by the sign of a reference vector for each angle (see Appendix I).

## 4. EXPERIMENTAL METHOD

### 4.1 Sample set up of data

To obtain all required data for 'set up', two computer programs must be run for a given overhead pass. The first program produces the position vectors of the aircraft in the E-axis system. Appendix II describes the program POSVEC.FORT, contains a sample list of position vectors produced by POSVEC.FORT and a copy of the file under which they are stored. The second program uses the position vectors produced by POSVEC.FORT and other input data to produce the four angles required to set up the model-mounting apparatus. Appendix III contains a guide to using this program, PVANG.FORT. Each set of angles produced by PVANG.FORT must be set up individually and all measurements taken before moving on to the next situation in the pass. Appendix III also contains a sample of the output for one situation (one position vector) as produced by PVANG.FORT.

### 4.2 Experimental procedure

The detector, using the procedure contained in reference 1, must first be calibrated and then installed, ensuring correct alignment within the collimator. The infrared source, which is left continually in "stand by" mode in order to keep the Nernst Glower hot and thus extend its life, must be switched into "operate" mode and also be checked for alignment within the collimator. The scale model under examination is then mounted onto the spindle (see figure 2) and the apparatus rotated as described in Section 3.3.3 to reproduce the situation being considered. When set up, the aircraft is removed from its mount and a reading is taken from the

radiometer. The model is then replaced and a new reading is taken. This procedure is repeated a number of times such that the difference between each pair is made, and as mentioned before, interpreted as reflected radiation from the model. The next situation can then be set up.

#### 4.3 Sample set of results

In order to test the complete system, a sample overhead pass was selected. The overhead pass was of an aircraft commencing at azimuth  $60^{\circ}$ T and elevation  $45^{\circ}$  and heading  $270^{\circ}$ . Fifteen position vectors were generated to describe this pass. The position of the sun was then defined as a typical summer noon position with azimuth  $0.0^{\circ}$ T and elevation  $85^{\circ}$ . For each of the fifteen position vectors, the four angles required to set up the model mounting apparatus, were generated. With the radiometer aligned and calibrated, each of the fifteen positions were set as described previously and a solar reflectance plot of the pass was produced (see figure 5).

### 5. CONCLUSIONS

The apparatus and operating procedure have been developed to enable measurement of infrared reflections from scale models. Specific geometric situations involving sun position, aircraft attitude and observer can be reproduced in the laboratory enabling that component of the aircraft's infrared signature due primarily to solar reflections to be independently measured.

An example of a solar reflectance plot is shown in figure 5. It shows the considerable variations at specific aspects that are typical of solar reflections from aircraft.

REFERENCES

No.	Author	Title
1	Johnson, R.P. and Dale, F.R.	"A Radiometer for Measurements in the SA-7 Missile Waveband". ERL-0208-TM, July 1981

THIS IS A BLANK PAGE

APPENDIX I

DERIVATION OF SETTING UP ANGLES FOR MODEL MOUNTING APPARATUS

The situation of an aircraft passing over an observer, with the sun at some fixed position in the sky, is transformed so that the plane containing the sun, aircraft and observer becomes the plane of the laboratory. The sun is represented by an infrared source and the observer is represented by a detector. This plane is termed the SAD plane (such that the aircraft axis system has its origin at the point A) as described in Section 3.3.1. Important vectors in this aircraft axis system are represented by the following:

$\vec{AS} = s_A$  is the vector from the aircraft to the sun

$\vec{AD} = d_A$  is the vector from the aircraft to the observer

$[1,0,0] = x_A$  is the unit vector defining the x axis of the Aircraft coordinate system

$[0,0,1] = z_A$  is the unit vector defining the z axis of the Aircraft coordinate system

As mentioned in the text, the angle between the source (sun) and the detector (observer) is obtained from:

$$a = \cos^{-1}(s_A \cdot d_A)$$

The remaining three angles to be evaluated,  $b$ ,  $c$  and  $d$ , correspond to the ordered rotations of the mount about its  $z$ -axis,  $y'$ -axis and  $x''$ -axis respectively. In order to follow these transformations a Cartesian coordinate system  $V$  is introduced based around the model mounting apparatus when it is set in its initial position (ie the  $V$ -axis system is to be rotated into the  $A$ -axis system). The initial orientation of the  $V$ -axis system is such that its  $x$ -axis  $x_V$  points towards the source and the  $x$ - $y$  plane of  $V$  is coincident with the SAD plane.

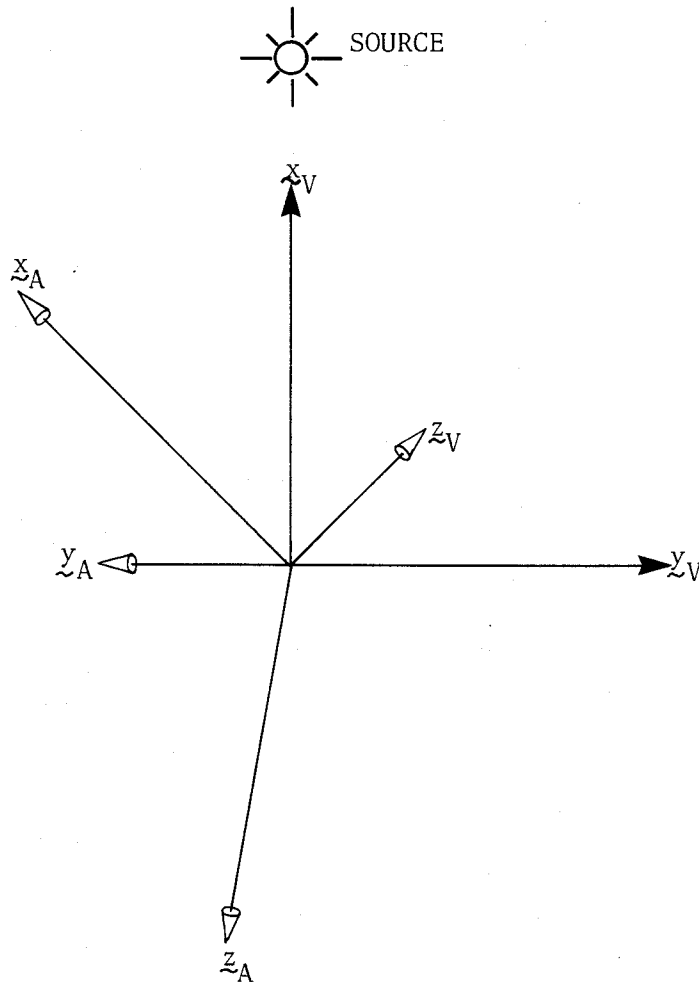

NOTE: SAD plane is plane of page thus contains  $x_V$  and  $y_V$

Sample initial set up

The first rotation,  $b$ , about the  $z$ -axis of  $V$  rotates  $x_V$  until it reaches a position directly below the vector  $x_A$ .

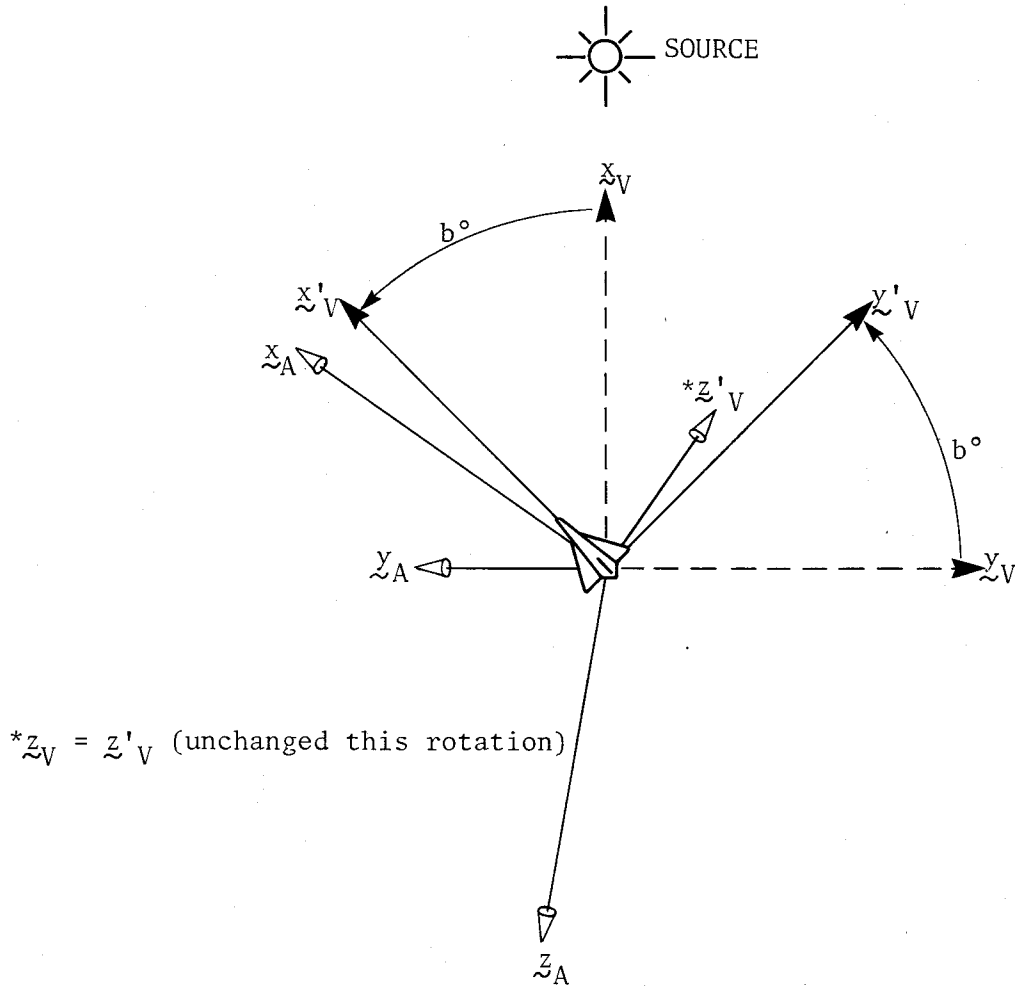

- NOTE: (1) This rotation maps the  $x_V, y_V, z_V$  axis system into the  $x'_V, y'_V, z'_V$  axis system
- (2)  $x_V, x'_V, y'_V, y_V$  are in plane of the page

After first rotation (about  $z$ -axis of  $V$ ) of  $b^\circ$

The required angle,  $b$ , for this rotation is determined by introducing the vector  $\lambda_A$  which lies in the SAD plane and is at right angles to  $x_A$ . After the first rotation it coincides with  $y'_V$ .

Thus  $\lambda_A = x_A \times n_A$  where  $n_A$  is the normal to the SAD plane in the direction OF the negative  $z_V$ -axis.

The  $x'$ -axis of the  $V$  coordinate system (ie  $x'_V$ ) is now defined by:

$$x'_V = n_A \times \lambda_A$$

The  $V$  coordinate system was, therefore, rotated an angle,  $b$ , where:

$$b = \cos^{-1}((n_A \times \lambda_A) \cdot s_A)$$

$$= \cos^{-1}(x'_V \cdot s_A)$$

The sense of this rotation is obtained from the z component of the vector  $x'_V \times s_A$ .

The second rotation, c, about the y-axis of V lifts  $x'_V$  out of the SAD plane, so as to coincide exactly with the vector  $x_A$ . The angle of rotation is simply the angle between  $x'_V$  and  $x_A$ . Thus:

$$c = \cos^{-1}(x'_V \cdot x_A)$$

The sense of this rotation is obtained from the y-component of the vector  $x'_V \times x_A$ .

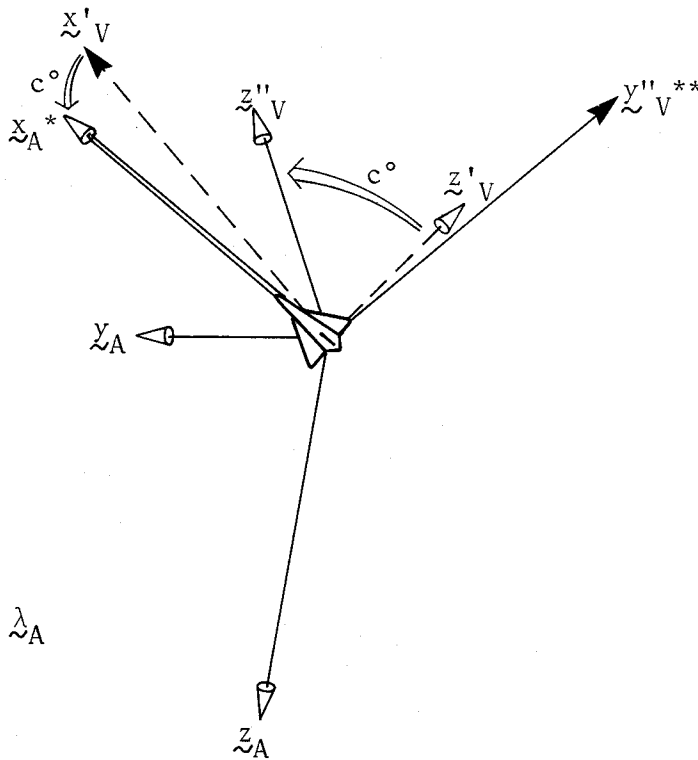
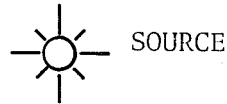

\*  $x_A = x''_V$   
 \*\*  $y''_V = y'_V = \lambda_A$

- NOTE: (1) This rotation maps the  $x'_V, y'_V, z'_V$  axis system into the  $x''_V, y''_V, z''_V$  axis system  
 (2) SAD plane is the plane of the page containing  $y''_V$

After second rotation (about y'-axis of V) of  $c^\circ$

The third rotation, d, is necessary to make the V axis system coincide with the A axis system and is achieved by rotating about the x-axis of V (ie  $x_A$ ). The angle of rotation is the angle between  $z_V$  and  $z_A$ . The vector  $z_V$  can be determined from  $z_V = x_A \times \lambda_A$  and thus the third angle, d, is:

$$d = \cos^{-1}((x_A \times \lambda_A) \cdot z_A) = \cos^{-1}(z_V'' \cdot z_A)$$

The sense of this rotation is obtained from the x-component of the vector  $z_V'' \times z_A$ .

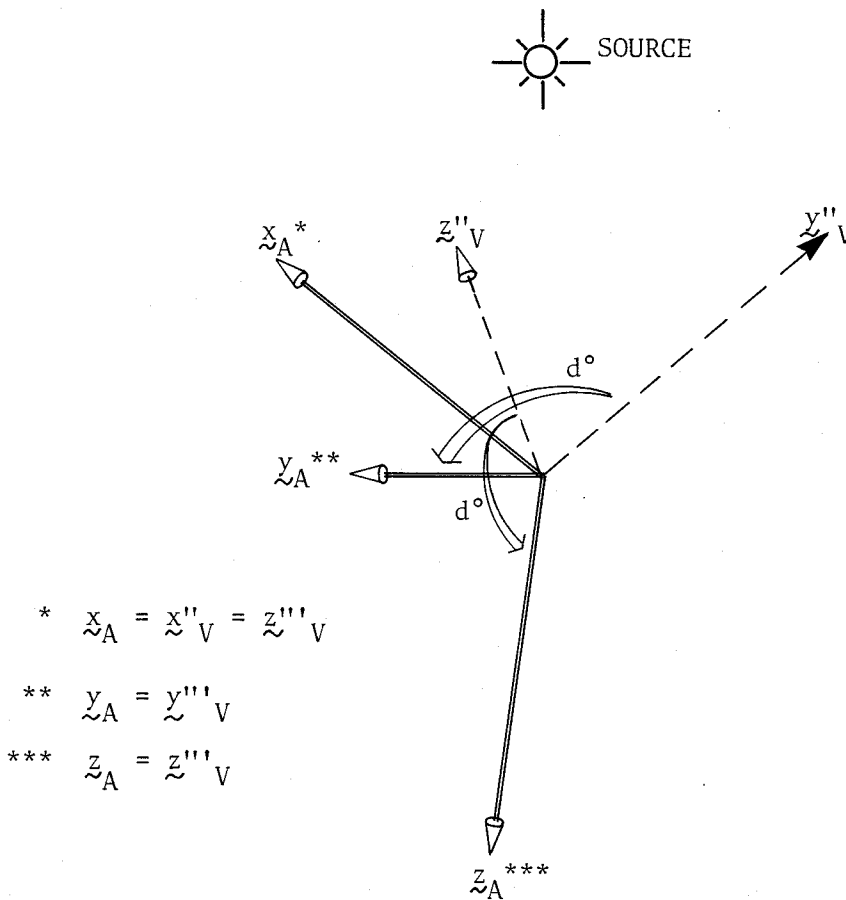

- NOTE: (1) This rotation maps the  $x''_V, y''_V, z''_V$  axis system into the  $x'''_V, y'''_V, z'''_V$  axis system which coincides exactly with the  $x_A, y_A, z_A$  axis system
- (2) SAD plane is the plane of the page

After third rotation (about  $x''$ -axis of V) of  $d^\circ$

Special cases in the derivation of the rotation angles arise where orthogonality is unattainable. One such case occurs if the source, aircraft and observer are colinear. In this case the position of the SAD plane is indeterminate. Checks for coincidence must therefore be made before vector product calculations are attempted.

## APPENDIX II

## DETERMINATION OF OVERHEAD PASS POSITION VECTORS

## II.1 Using POSVEC.FORT

Prior to running this program the dataset POSVEC.DATA must be allocated to logical unit no 9. Following this allocation the program POSVEC.FORT is run, and the user prompted for 4 pieces of information:

- (a) Aircraft's initial elevation (in degrees)
- (b) Aircraft's initial azimuth (in degrees)
- (c) Aircraft's heading (in degrees True North)
- (d) Number of position vectors required

Following the calculation of the required number of position vectors, they can be displayed and the user is given the option to save the position vector or quit the program in order to try some other parameters. If the position vectors are satisfactory the heading and the number of position vectors are appended to the beginning of the list and the list is stored in a previously allocated dataset POSVEC.DATA.

## II.2 Sample output

Following the running of the program the data can be found in the dataset POSVEC.DATA. Given the following input parameters the output is shown below:

Aircraft's initial elevation	5°
Aircraft's initial azimuth	90°
Aircraft's heading	270°T
Number of position vectors	5

## Output

```
4.71239
5.00000
0.281539
0.666066
-0.690728
0.30212
0.599444
-0.741209
0.32297
0.517544
-0.792363
0.34281
0.418494
-0.84103
0.359836
0.301938
-0.882809
```

This output confirms that the heading was  $270^{\circ}$ T (ie 4.71239 rad) and that five position vectors were asked for. These position vectors are actually:

- (1) [0.282, 0.666, -0.691]
- (2) [0.302, 0.599, -0.741]
- (3) [0.323, 0.518, -0.792]
- (4) [0.343, 0.418, -0.841]
- (5) [0.360, 0.302, -0.883]

## II.3 Flow diagram

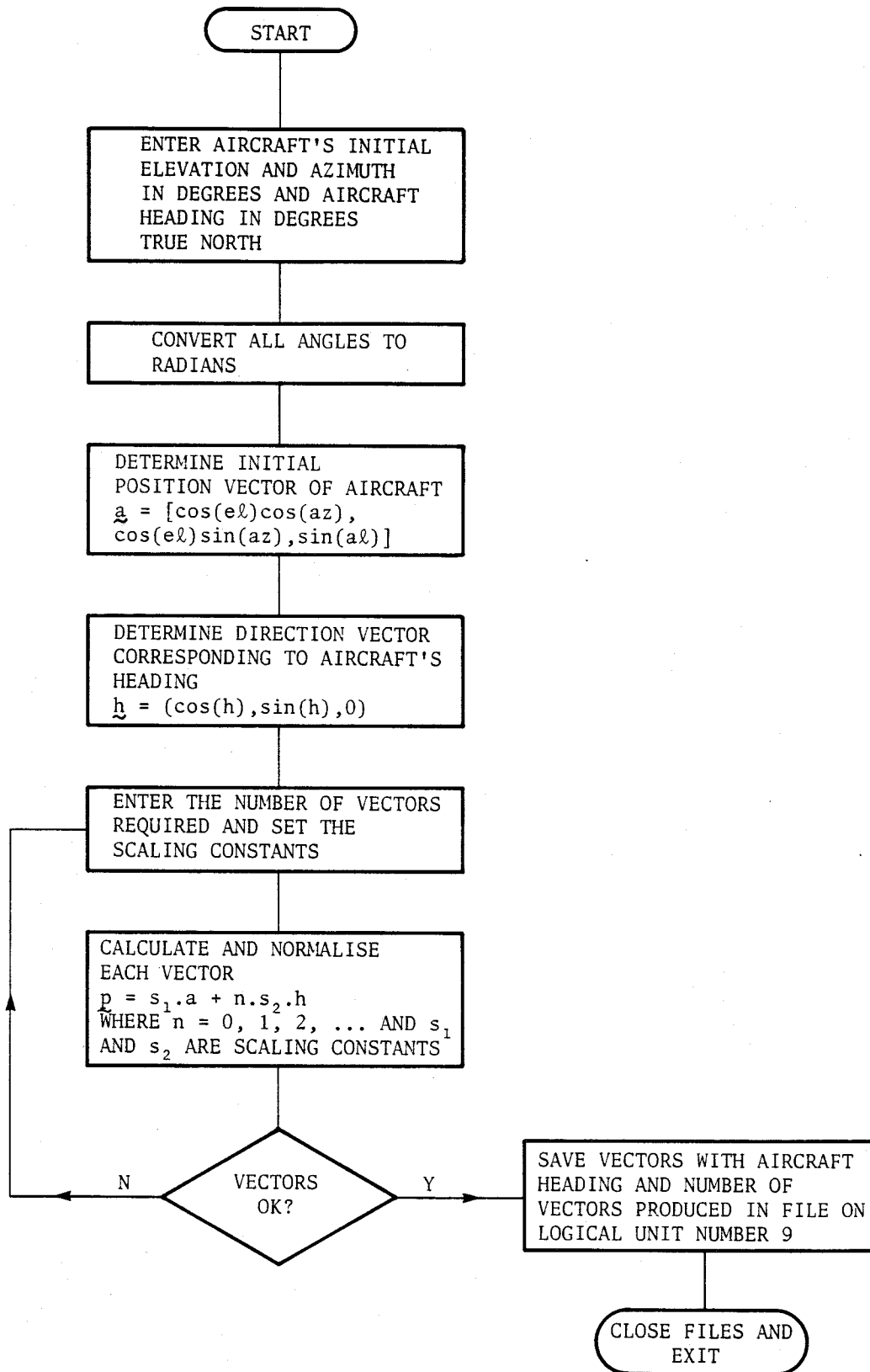

APPENDIX III

DETERMINATION OF SET UP ANGLES FOR THE MODEL MOUNTING APPARATUS

III.1 Guide to using PVANG.FORT

The only allocation required prior to the running of the program PVANG (that determines all set up angles) are those allocating the input dataset POSVEC.DATA to logical unit number 1 and those allocating the output dataset RESULTS.DATA to logical unit number 8.

Upon running the program PVANG, the user is prompted for the azimuth of the sun in degrees true north and the elevation of the sun in degrees above the horizon. All other required input (aircraft heading and position) is found in the allocated input dataset.

III.2 Sample output

As stated above, the output is found in the dataset RESULTS.DATA. Only the required information for setting the model mounting apparatus are given together with the relevant position vector as read from the POSVEC.DATA dataset. A position of a sample output appears below:

THE HEADING IS 270.00°  
SUN POSITION : AZIMUTH 0.0  
                  ELEVATION 85.0

POSITION VECTOR NUMBER 1  
THE POSITION VECTOR OF THE A/C IN "D" AXES  
(0.282, 0.66, -0.691)

THE ANGLE "A" 224.55  
THE ANGLE "B" 270.00  
THE ANGLE "C" 18.30  
THE ANGLE "D" 275.00

III.3 Flow diagram

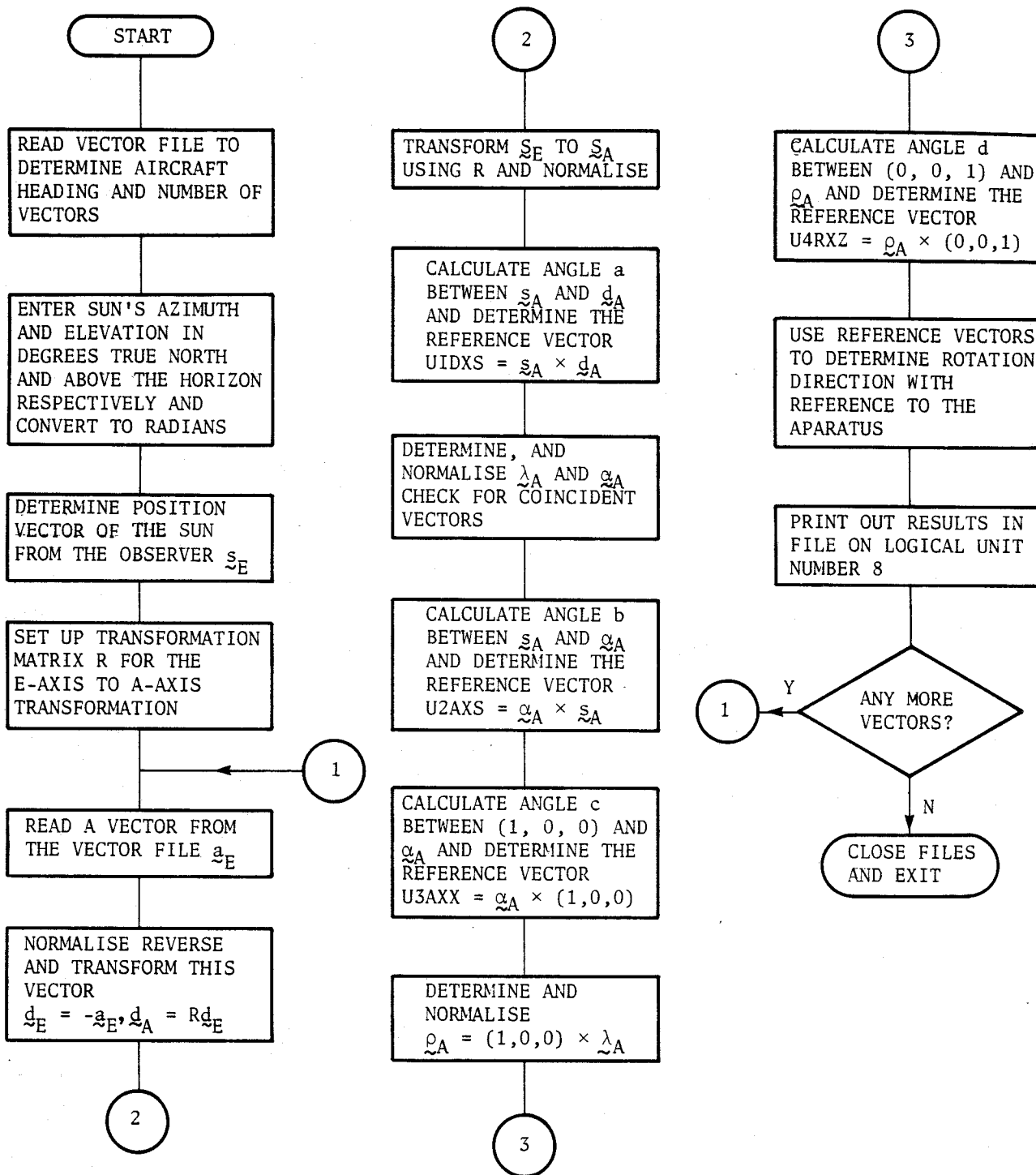

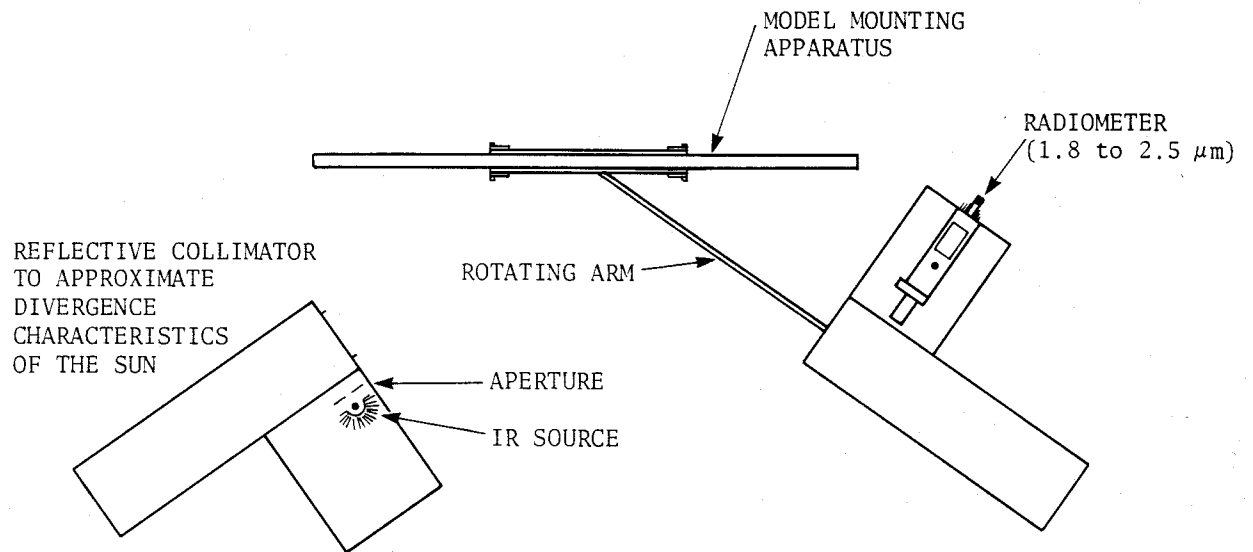

Figure 1. General assembly

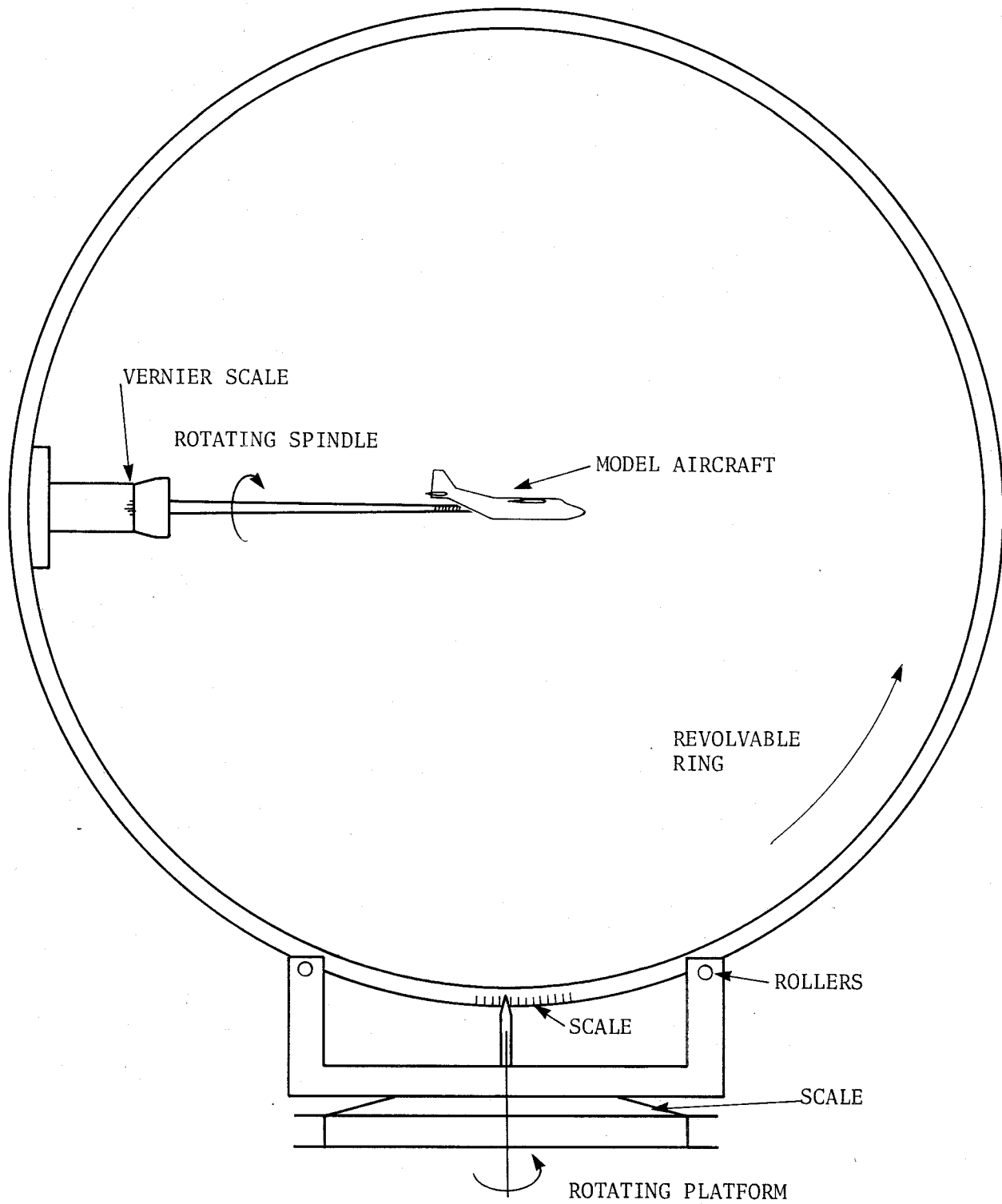

Figure 2. The model mounting apparatus

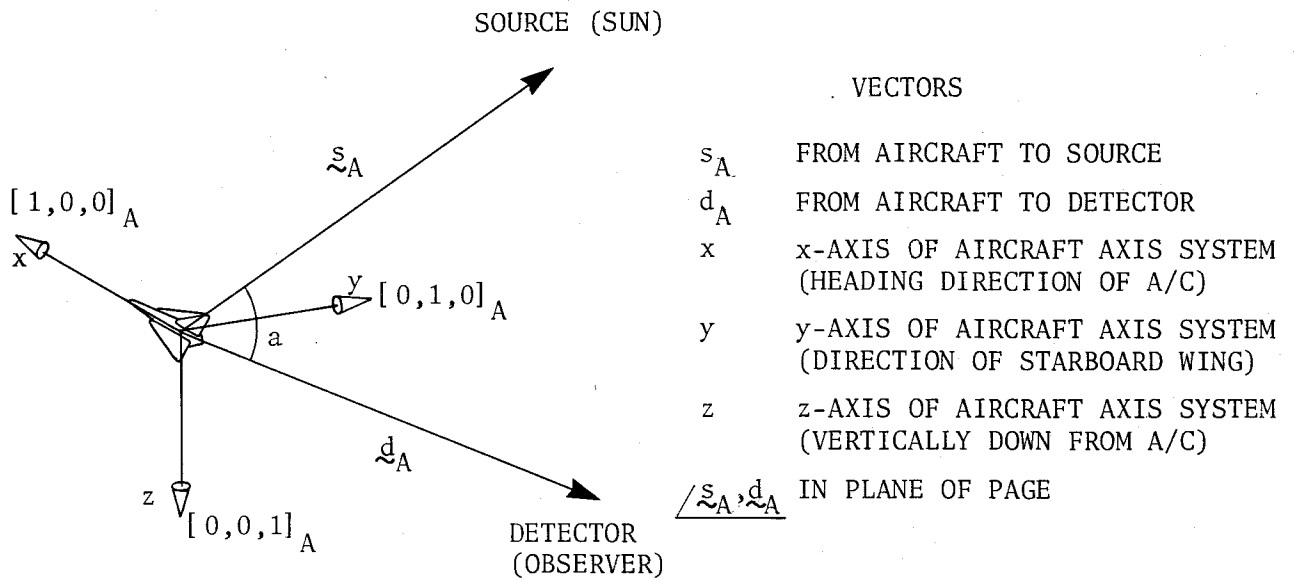

Figure 3. SAD plane and the aircraft axis system in the final orientation

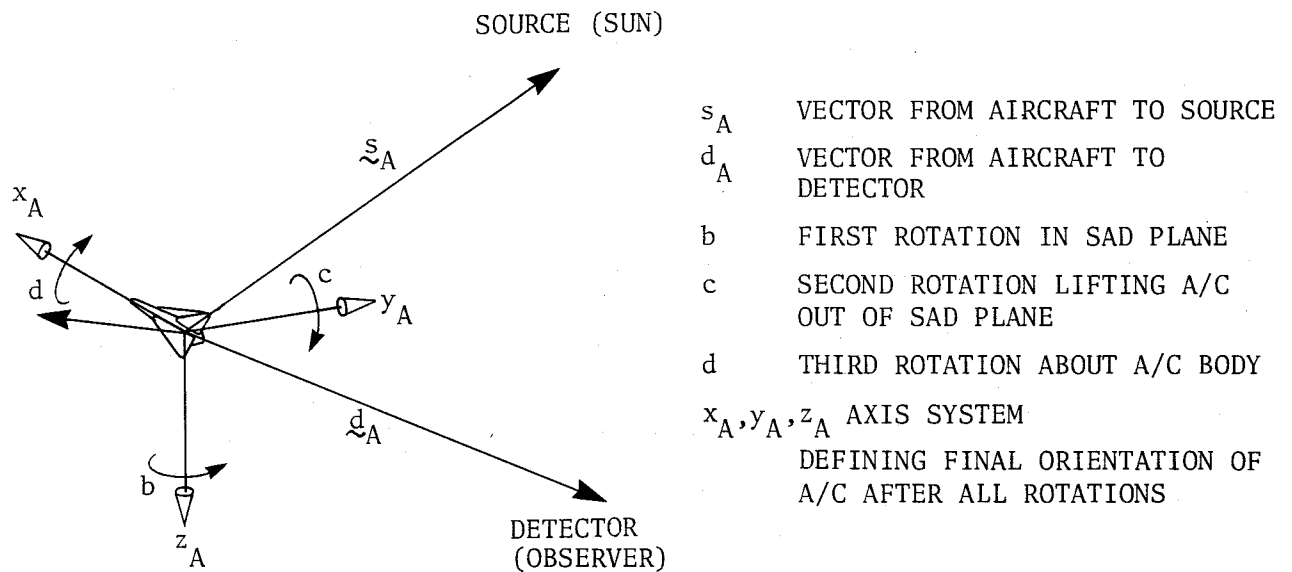

Figure 4. Aircraft rotations on the model mounting apparatus

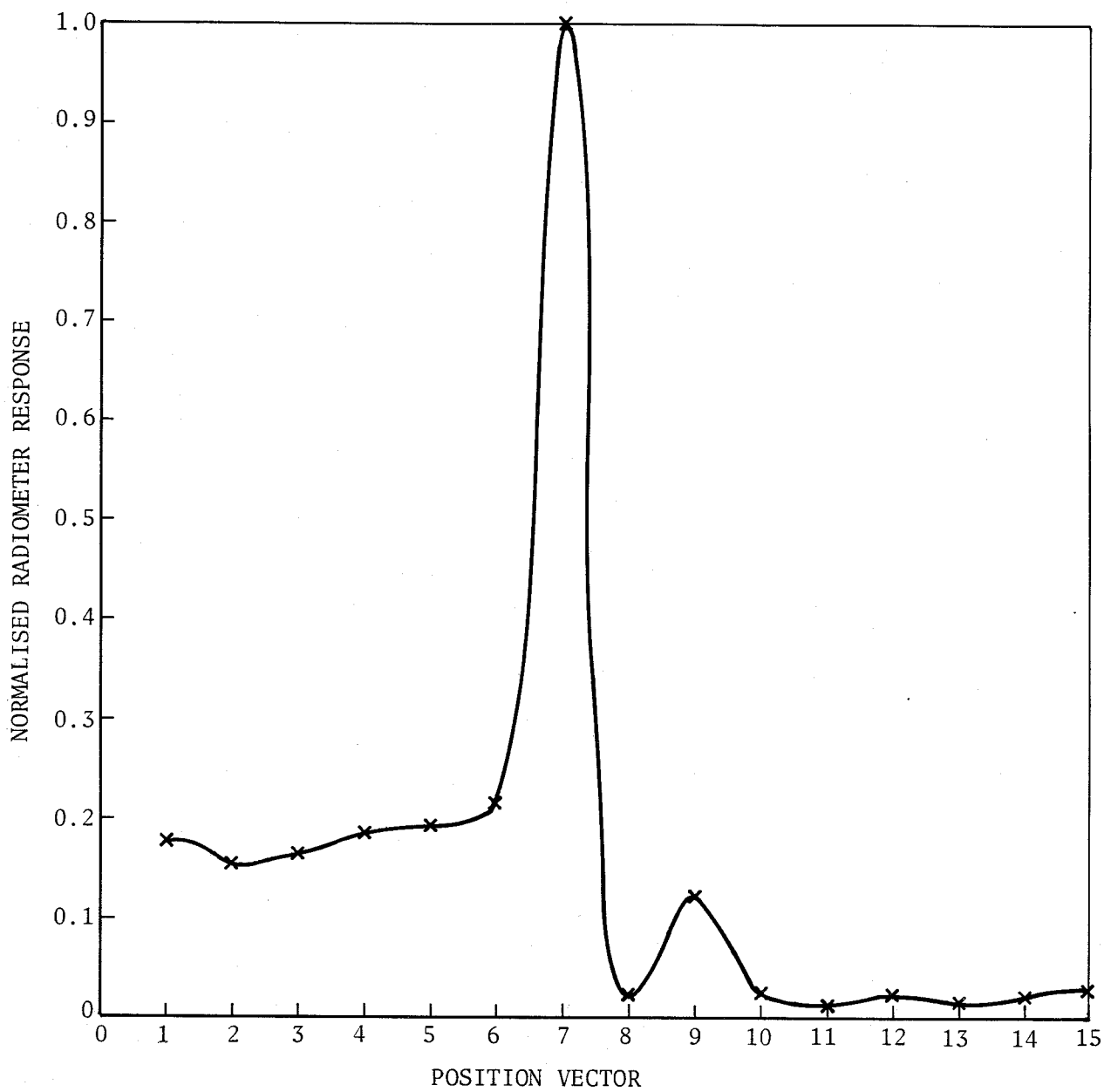

Figure 5. Solar reflectance plot

## DOCUMENT CONTROL DATA SHEET

Security classification of this page

UNCLASSIFIED

<p>1 DOCUMENT NUMBERS</p> <p>AR Number: AR-004-854</p> <p>Series Number: ERL-385-TM</p> <p>Other Numbers:</p>	<p>2 SECURITY CLASSIFICATION</p> <p>a. Complete Document: Unclassified</p> <p>b. Title in Isolation: Unclassified</p> <p>c. Summary in Isolation: Unclassified</p>
<p>3 TITLE</p> <p>A LABORATORY FACILITY FOR MEASURING SOLAR REFLECTIONS FROM MODEL AIRCRAFT</p>	
<p>4 PERSONAL AUTHOR(S):</p> <p>R.J. Oermann</p>	<p>5 DOCUMENT DATE:</p> <p>June 1986</p> <p>6 6.1 TOTAL NUMBER OF PAGES 22</p> <p>6.2 NUMBER OF REFERENCES: 1</p>
<p>7 7.1 CORPORATE AUTHOR(S):</p> <p>Electronics Research Laboratory</p> <p>7.2 DOCUMENT SERIES AND NUMBER</p> <p>Electronics Research Laboratory 0385-TM</p>	<p>8 REFERENCE NUMBERS</p> <p>a. Task: 83/153</p> <p>b. Sponsoring Agency:</p> <p>9 COST CODE:</p> <p>136</p>
<p>10 IMPRINT (Publishing organisation)</p> <p>Defence Research Centre Salisbury</p>	<p>11 COMPUTER PROGRAM(S) (Title(s) and language(s))</p>
<p>12 RELEASE LIMITATIONS (of the document):</p> <p>Approved for Public Release.</p>	

Security classification of this page:

UNCLASSIFIED

## 13 ANNOUNCEMENT LIMITATIONS (of the information on these pages):

No limitation

## 14 DESCRIPTORS:

a. EJC Thesaurus  
TermsSolar radiation  
Simulation  
Reflection  
Aircraft detection  
Infrared signaturesb. Non-Thesaurus  
Terms

## 15 COSATI CODES:

17110

## 16 SUMMARY OR ABSTRACT:

(if this is security classified, the announcement of this report will be similarly classified)

A laboratory facility has been developed to simulate solar reflections from military aircraft. Scale models are placed in a mount which enables orientation in any chosen attitude. A fixed infrared source is collimated to simulate the sun and a mobile detector accepts reflected radiation in the 1.8  $\mu\text{m}$  waveband.

A computer program generates the relevant parameters necessary to describe the aircraft's attitude in the frame of reference which includes both the observer and the sun. A group of such parameters enables an entire overhead pass of an aircraft to be simulated.

The resultant relative reflectance plot gives an indication of the radiance from an aircraft primarily due to solar reflection.