

ATOMIC AND QUARTZ CLOCK HARDWARE FOR COMMUNICATION AND NAVIGATION SATELLITES*

Leo A. Mallette
The Boeing Company
Los Angeles, CA 90009, USA

Abstract

Accurate and stable frequency reference sources are critical for commercial, navigation, military, and scientific space applications. Each piece of flight hardware has requirement-types that are generic such as size, weight, power, and reliability, and requirement-types that are specific to the hardware function. The key requirement-types for frequency reference sources are phase noise and stability. Both are important for satellites, but stability is especially important for navigation satellites. Several levels of frequency references are suitable for space applications. This paper discusses similarities and differences among single distributed oscillators for communications satellites, master oscillator groups for communications systems, and atomic clocks for military and navigation systems.

INTRODUCTION

Lewis [1] introduces frequency standards and provides a review that was intended as a guide for selecting devices for a particular application. He uses stability as his primary discriminating measure. His paper is oriented to ground systems; this paper focuses on clocks for space hardware. White and Beard [2] begin their paper by stating “atomic clocks for use in operational satellites such as GPS and MILSTAR are a breed apart from their terrestrial cousins” (p. 7). Most of us would agree that this sentiment also is true of quartz-based oscillators. Each piece of flight hardware has both requirement-types that are generic, such as SWAP (size, weight, and power) and reliability, and requirement-types that are specific to the hardware function, such as output power, noise figure, axial ratio, gain, throughput, capacity, group delay, pointing accuracy, or depth of discharge. The two key requirement-types for frequency reference sources are phase noise and stability.

PHASE NOISE

Phase noise, coupled with other contributors, decreases signal-to-noise ratios, leads to jitter, degrades Bit-Error-Rate (BER), generates inter-symbol interference (ISI), leads to earlier loss of lock, and negatively affects acquisition thresholds. When discussing phase instability Gagliardi [3] includes “random phase variations (phase noise) and random phase offsets (i.e. constant phase shifts) due to differential phase

*Copyright ©2007 The Boeing Company. All rights reserved.

Report Documentation Page

Form Approved
OMB No. 0704-0188

Public reporting burden for the collection of information is estimated to average 1 hour per response, including the time for reviewing instructions, searching existing data sources, gathering and maintaining the data needed, and completing and reviewing the collection of information. Send comments regarding this burden estimate or any other aspect of this collection of information, including suggestions for reducing this burden, to Washington Headquarters Services, Directorate for Information Operations and Reports, 1215 Jefferson Davis Highway, Suite 1204, Arlington VA 22202-4302. Respondents should be aware that notwithstanding any other provision of law, no person shall be subject to a penalty for failing to comply with a collection of information if it does not display a currently valid OMB control number.

1. REPORT DATE NOV 2007	2. REPORT TYPE	3. DATES COVERED 00-00-2007 to 00-00-2007			
4. TITLE AND SUBTITLE Atomic and Quartz Clock Hardware for Communication and Navigation Satellites		5a. CONTRACT NUMBER			
		5b. GRANT NUMBER			
		5c. PROGRAM ELEMENT NUMBER			
6. AUTHOR(S)		5d. PROJECT NUMBER			
		5e. TASK NUMBER			
		5f. WORK UNIT NUMBER			
7. PERFORMING ORGANIZATION NAME(S) AND ADDRESS(ES) The Boeing Company, Los Angeles, CA, 90009		8. PERFORMING ORGANIZATION REPORT NUMBER			
9. SPONSORING/MONITORING AGENCY NAME(S) AND ADDRESS(ES)		10. SPONSOR/MONITOR'S ACRONYM(S)			
		11. SPONSOR/MONITOR'S REPORT NUMBER(S)			
12. DISTRIBUTION/AVAILABILITY STATEMENT Approved for public release; distribution unlimited					
13. SUPPLEMENTARY NOTES 39th Annual Precise Time and Time Interval (PTTI) Meeting, 26-29 Nov 2007, Long Beach, CA					
14. ABSTRACT Accurate and stable frequency reference sources are critical for commercial, navigation, military, and scientific space applications. Each piece of flight hardware has requirement-types that are generic such as size, weight, power, and reliability, and requirement-types that are specific to the hardware function. The key requirement-types for frequency reference sources are phase noise and stability. Both are important for satellites, but stability is especially important for navigation satellites. Several levels of frequency references are suitable for space applications. This paper discusses similarities and differences among single distributed oscillators for communications satellites, master oscillator groups for communications systems, and atomic clocks for military and navigation systems.					
15. SUBJECT TERMS					
16. SECURITY CLASSIFICATION OF:			17. LIMITATION OF ABSTRACT	18. NUMBER OF PAGES	19a. NAME OF RESPONSIBLE PERSON
a. REPORT unclassified	b. ABSTRACT unclassified	c. THIS PAGE unclassified			

effects, such as medium dispersion and device delay” (p. 321). Gagliardi also points out that “the primary sources of phase noise are the system oscillators, which generate the link carriers and mixing frequencies, and the additive thermal noise, which is directly converted to phase noise by amplitude limiting, power amplification, and carrier extraction” (p. 321).

Three Web sites suggest the following definitions of phase noise:

“a frequency domain measure of stability and is usually expressed as the SSB spectral density in dBc/Hz. This is the single-sideband noise and is denoted by L(f). It is important in many applications and has direct correlation to the short term stability. ...” [4, p. 1]

“In the frequency domain, an ideal carrier would appear as an infinitesimally thin line. The typical carrier however, will have skirts whose amplitudes generally follow 1/f distribution with increasing video frequencies. These skirts are the envelope of side bands due to modulations of the carrier, and are both FM and AM in nature, random in both frequency and amplitude, and are caused by various phenomena relating to the physics of the particular oscillator, and are commonly referred to as ‘NOISE’ ...” [5, p. 1]

“In an oscillator, phase noise is rapid, short-term, random fluctuations in the phase of a wave, caused by time domain instabilities....” [6, p. 1]

With the exceptions of steady-state acceleration, gravity change, shock, and vibration effects [18], the satellite environment does not significantly affect phase noise. The space radiation environment, even in the presence of solar flares, is not a significant contributor to phase noise. For example, Presser and Camparo [7] found “clear evidence of a flare-induced deterministic change in oscillator frequency [but] found no evidence of a concomitant change in the nature of the oscillator’s stochastic behavior” (p. 2605). Phase noise is usually measured “as single sideband power in relation to the fundamental RF output frequency, and measured at various offset frequencies from the carrier, normalized to a one hertz measuring bandwidth (example -120 dBc/Hz/100 KHz, offset)” [5, p. 1].

STABILITY

Accuracy, stability, and precision are well defined by Vig [8]:

“**Accuracy** is the extent to which a given measurement, or the average of a set of measurements for one sample, agrees with the definition of the quantity being measured. It is the degree of ‘correctness’ of a quantity ... **Stability** describes the amount something changes as a function of parameters such as time, temperature, shock, and the like. **Precision** is the extent to which a given set of measurements of one sample agrees with the mean of the set.” (p. 93)

Most frequency standards have frequency stabilities which decrease, down to a limit determined by the technology, as the square-root of the measurement interval. “This behavior occurs because the noise process is dominated by the statistics of counting quantum transitions, which varies as the square-root of the number of transitions” [1, p. 927]. Stability usually is measured statistically using the Allan deviation or the Hadamard deviation. The measurement interval in seconds is plotted on the abscissa and the deviation in Hz/Hz is plotted on the ordinate.

In the introductory section, phase noise and stability are defined and identified as the two most significant parameters for a space clock. The next section describes why they are important and explains why stability is more important for navigation satellites.

SATELLITE CLOCKS

This section describes oscillator needs for communications and navigation satellites and for scientific space missions.

COMMUNICATION SATELLITES

A land-based RF carrier digital communications system is subject to degradation by phase noise [9]. This communications path is further degraded by the addition of a satellite in the path because the bit-error-rate of the phase-shift keyed modulation will increase due to the satellite's phase noise. In a traditional bent-pipe satellite design, "the translation oscillator adds phase modulation noise [and] the sidebands are transferred to all carriers that pass through the mixer stage" [10, p. 239]. The term "Bent-pipe satellite" refers to the single frequency translation associated with many commercial communication satellites. For example, DirecTV signals are transmitted to the geostationary satellite in a band around 17 GHz, translated by 4.5 GHz, and amplified for rebroadcast to the rooftop dishes at 12.5 GHz. Crystal oscillators are commonly used on communication satellites.

Phase noise in low-frequency oscillators is increased when the signal is multiplied to higher frequencies. The oscillator's phase noise sidebands are enhanced by $20 \log(N)$ when a signal passes through a multiplier of factor N . A 10 MHz signal with phase noise of -100 dBc/Hz at 10 Hz would become -60 dBc/Hz at 10 Hz when multiplied to 1 GHz ($N=100$). This is important because most satellites need reference signals in the range of a few GHz to a few tens of GHz. The DirecTV example above required a translation frequency of 4.5 GHz, which, for a 10 MHz oscillator, is a multiplication factor of 450. The resultant phase-noise sideband would be degraded by 53 dB. The "low-frequency phase noise (below about 1-10 Hz) tends to dominate, due to the inverse frequency flicker effect, with a fairly rapid spectral rise occurring at the extremely low frequencies" [3, p. 322]. Higher offset frequencies are less sensitive because of phase-noise roll-off and the availability of narrow bandpass filters to filter the signal. However, far-out noise should not be ignored in many applications. For example, in an application with two adjacent signals where one signal has significantly lower signal strength than the other, the phase noise of the stronger signal may significantly degrade the signal-to-noise ratio of the weaker signal.

Crystal oscillator phase noise is the driver for most communication satellite systems, but some satellites have different driving requirements, such as survivability and autonomy. These requirements "are the key system requirements that drive the need for on-board atomic frequency standards, instead of the traditional quartz frequency standards" [11, p. 3]. Furthermore, "secure communication techniques in general require more stable frequency and time references than conventional communication systems" [12, p. 1057].

NAVIGATION SATELLITES

Atomic Frequency Standards (AFS) have been used on navigation systems since the 1970s. The first satellite navigation was realized in the 1960s with the US Navy's Navigation Satellite System known as TRANSIT. The TRANSIT satellites were launched with quartz-crystal oscillators (XOs). In 1964, the Navy started the TIMATION program, a predecessor to GPS. The TIMATION developmental satellites (TIMATION-1 and -2) used high performance XOs and time-referenced ranging signals. In 1974, TIMATION-3 (later Navigation Technology Satellite – NTS-1) was the first satellite to carry onboard rubidium AFSs. NTS-2, which was launched in 1977, was the first satellite to carry a pair of cesium AFSs. The superior frequency stability of the AFSs made satellite navigation a practical system to operate. The two current navigation systems are the Russian Global Navigation Satellite System (GLONASS) [13] and the Global Positioning System (GPS) [14]. Future navigation systems with AFSs

include the Galileo system, China's Beidou (a.k.a. Compass) satellite positioning system, and Japan's quasi-zenith satellite system (QZSS) [13].

Navigation satellites have satellite-generated communication links to the ground, and the signal levels from the satellites are very low. Therefore, it is essential that the satellites be very stable so the ground receivers know precisely the transmitter frequency and time in order to 1) recover the carrier, 2) recover the clock, and 3) align to the PRN code. For these reasons, both phase noise and stability are critical to being able to track the signal and demodulate the data. All precision navigation satellites use AFSs.

SCIENTIFIC MISSIONS

Most spaceborne scientific missions use crystal oscillators, some use a master oscillator group, but very few have used AFSs. Phase noise is important for the reasons described above, but stability was important for some scientific missions. The ones that have used AFSs include the hydrogen maser on the Gravity Probe-A experiment in 1976; rubidium and cesium clocks on the navigation experiment (NAVEX) aboard Shuttle flight STS-61A in 1985; rubidium clocks on the Cassini-Huygens mission to Saturn's moon Titan from 1997 to 2005 [13]; and cesium clocks on Japan's ETS-VIII satellite in 2006 [15].

In summary, the user must be careful about general conclusions, because exceptions do exist. Phase noise is the important requirement for communication satellites and scientific missions, and both phase noise and stability are very important to navigation systems.

EXAMPLES OF SPACE CLOCKS

This section describes the different levels of complexity for space clocks, from crystal oscillators to master oscillator groups and atomic frequency standards. The subsections discuss characteristics, advantages, and disadvantages of each type and shows pictures of examples from several manufacturers.

CRYSTAL OSCILLATOR (XO)

The basic XO can be obtained in many manifestations, including voltage-controlled (VCXO), microprocessor-controlled (MCXO), temperature-compensated (TCXO), oven-controlled (OCXO), low g-sensitivity – acceleration-compensated (ACXO), and combinations of the above. They are small and inexpensive. They have relatively low mass and low power consumption when compared to the master oscillator groups and atomic frequency standards described below. XOs can be installed inside of a host unit such as a transmitter, a receiver, or a reference frequency generator. Some of the disadvantages of XOs are that they are not redundant; they require a regulated power supply; they have minimal or no telemetry and command capability; and they are not coherent with each other when placed in various locations on the satellite. The Geosynchronous Operational Environmental Satellites (GOES) use distributed crystal oscillators [16], as do many other satellites. Figures 1 to 4 show examples of space-qualified crystal oscillators from several manufacturers.



Figure 1. Model 9920 hybrid space-qualified crystal oscillator (courtesy of Symmetricom).



Figure 2. Crystal oscillator (courtesy of SpectraTime).



Figure 3. Model 9700 series crystal oscillator (courtesy of Symmetricom).



Figure 4. Model FE-103A low-phase-noise crystal oscillator (courtesy of Frequency Electronics).

Because crystal oscillators can be made with a crystal resonator and a handful of components, the advantages of the space crystal oscillators are small size, as small as 2 cubic inches, or less; low cost, as low as a few percent of the cost of a master oscillator group; low mass, as low as a few ounces; and low power consumption, as low as 200 mA for an XO and 2-3 watts for an OCXO.

The preceding subsection describes XOs and their advantages (small, inexpensive, low mass, low power consumption, and insertable into a host unit), disadvantages (are not redundant, require a power supply, have minimal telemetry and command, and are not coherent with each other), and presented examples of space-qualified crystal oscillators from several manufacturers. The next subsection introduces the master oscillator group (MOG)

MASTER OSCILLATOR GROUP (MOG)

A master oscillator (MO) is a crystal oscillator that is used as the source for most or all frequency reference on the satellite. As the name implies, a master oscillator group (MOG) is a group of master oscillators. The MOG also includes the circuitry needed to support multiple oscillators and amplifiers. A MOG centralizes multiple crystal oscillators, higher output power, a distribution network with multiple outputs, a power supply, and switching for redundancy into one box or unit. A MOG may have frequency update capability, may have extensive telemetry and command capability, and may require special isolation for a hot backup. Figure 5 shows a simple block diagram of a master oscillator group.

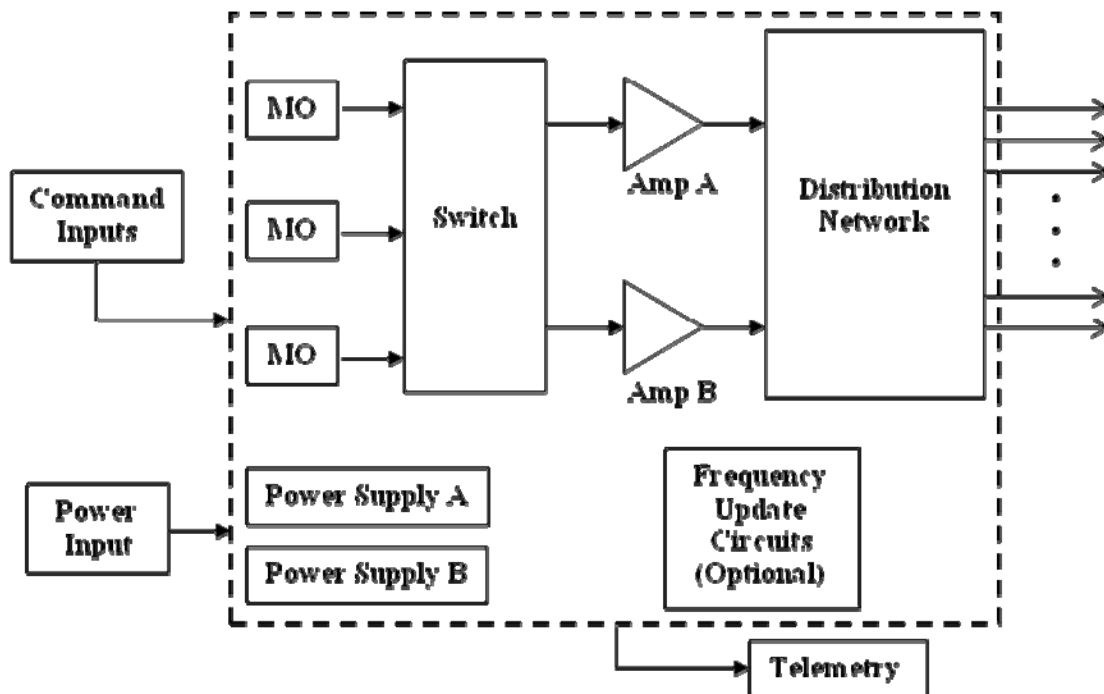

Figure 5. Simplified block diagram of a Master Oscillator Group with triple-redundant oscillators, redundant circuits, multiple RF outputs, and interfaces for power, command, and telemetry.

Each of the various transmitters, receivers, reference generators, and processors on a satellite may require a frequency source input. This drives the MOG to have a distribution network with multiple outputs. A MOG distribution network may have as many as 60 output ports. Amplifiers are required to boost the MO signal so that it can be divided amongst the multiple outputs. Even though oscillators are the primary source of phase noise, “secondary sources of phase noise are excess noise in ... distributed amplifiers ... [and] generally contribute significantly lesser (but not always negligible) amounts of phase noise relative to the oscillators themselves” [3, p. 321].

In order to satisfy reliability requirements, an MOG may contain one or two or three master oscillators and redundant amplifiers. These redundancies require the MOG to have the capabilities to switch from one oscillator to another and from one amplifier to another. This switching can be mechanical or electronic, active or passive. Normally, one oscillator is on and supplying the stable signal to one of the amplifiers and is subsequently distributed to the various satellite units. The other one or two MOs are commanded off.

Occasionally, two (or more) oscillators are required to be powered on at the same time. One is the primary source for the satellite and the second one may be a *hot backup* in case the first one needs to be commanded off. This requires high isolation between the two oscillators so that the signal from the *hot backup* oscillator does not appear as a spurious signal on the primary signal.

During system test, all three MOs in a triple-redundant MOG may need to be powered on at the same time. In order to test all the redundant signals and command paths in the satellite over all test conditions, each path may need to be exercised in each system test phase, including each of the hot, cold, and ambient test phases. It is impractical for the test team to wait repeatedly for an oscillator to warm up from an off condition, as meeting the required stability requirement takes hours or even days each time a unit is powered on. Generally, all the MOs in the MOG are commanded on at the beginning of the test phase and kept powered on throughout the test phase. This allows switching among MOs without the associated warm-up time. Therefore, even if high isolation among the MOs is not needed for the satellite mission operating requirement; it may be required for system test.

A power supply is a necessary component of the MOG. It converts the satellite bus voltage to voltages (i.e., +5 V, -5 V, and +15 V) useful to the circuit components, the oscillators, amplifiers, telemetry and command, and logic circuits that comprise the MOG. One key parameter of an MOG power supply is the ability to filter the noise that is on the satellite bus; the power supply must eliminate modulation of the oscillator's RF signal by narrowband, wideband, or intermittent noise sources.

The MOG has more telemetry and command capability than a crystal oscillator. A typical XO may require no commands; the XO is turned on by voltage applied to the oscillator when the host unit is turned on. Whereas, the MOG may have a variety of commands to turn individual MOs on and off, to switch among them, to switch redundant power supplies, to cross-strap the MO and amplifiers, and to adjust frequency. Telemetry on an MOG can include MO on/off status, power supply on/off status, amplifier on/off status, VCXO voltage, oven status, critical voltages, and temperature(s). Figures 6 to 8 show examples of space-qualified master oscillator groups from several manufacturers.



Figure 6. Model 9500 satellite master oscillator (courtesy of Symmetricom).

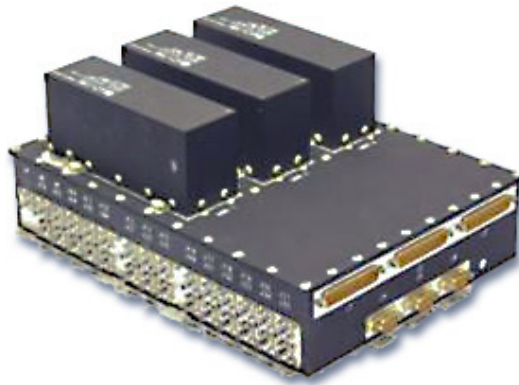

Figure 7. Syracuse triple-redundant Master Oscillator Group with 60 outputs (courtesy of Frequency Electronics).

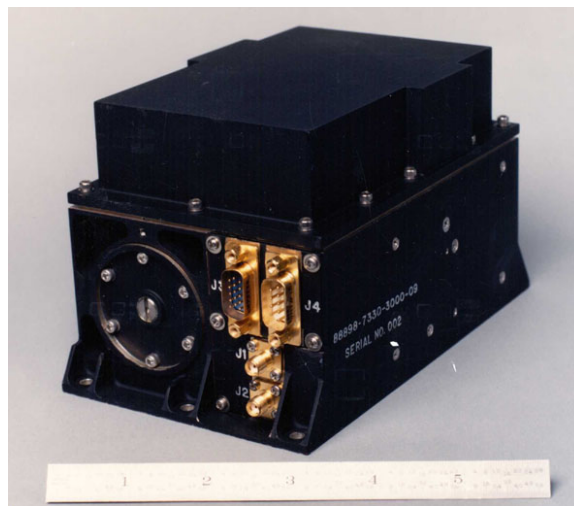

Figure 8. Ultra-stable oscillator launched January 2006 to support the Radio Science Experiment at Pluto (courtesy of JHU/APL).

The preceding subsection describes MOG characteristics such as multiple centralized crystal oscillators, a higher output power, a distribution network with multiple outputs, a power supply, telemetry and command capabilities, and a switching capability for redundancy. It presents examples of space-qualified MOGs from several manufacturers. The following subsection describes the characteristics of Atomic Frequency Standards.

ATOMIC FREQUENCY STANDARDS (AFS)

Space-qualified atomic frequency standards (AFS) are used primarily in navigation satellites, but are also found in specialized communication satellites and scientific missions. A general introduction to AFSs is found in McCoubrey [17]. He describes molecular and atomic beam methods, buffered gas cell resonance devices, and masers. AFSs have lower drift rate and inherent insensitivity to radiation when compared to conventional crystal oscillators. This makes them preferred for specialized space applications, such as navigation, precise timing, and survivability, and for autonomous operation.

AFSs use a voltage-controlled quartz crystal oscillator (VCXO) that is typically frequency locked to either a rubidium or cesium physics package (see *atomic resonator* in Figure 9). An AFS is a single oscillator like a crystal oscillator, but it has many of the attributes of a master oscillator group, i.e., a power supply, telemetry and command, and in some cases, frequency update capability. The requirements of many scientific, military-communication, and navigation missions only can be met with an AFS on the satellite. Figures 10 to 16 show examples of space-qualified AFSs from several manufacturers.

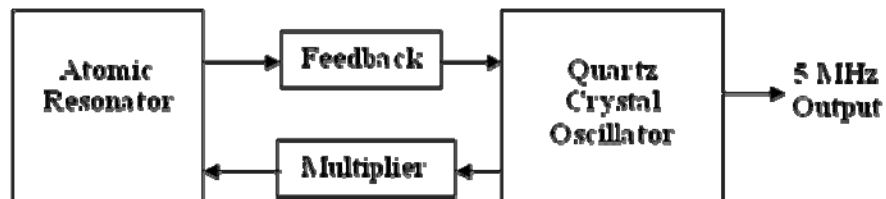

Figure 9. Simple block diagram of a typical atomic frequency standard with a 5 MHz output frequency, per Vig [8]; used with permission.



Figure 10. Rubidium clock for Galileo (courtesy of SpectraTime).

AFSs are stand-alone, nonredundant units that have been or will be flown singly (Cassini-Huygens – one on the Huygens probe and one on the Cassini orbiter) or in groups of two (GP-A, NAVEX, GIOVE-A), three (GLONASS, GPS-IIR, GPS-IIF, AEHF, GALILEO, QZSS, IRNSS), or four (GPS-II/IIA, Milstar) [13]. If required, switching is provided by an external unit and by commanding individual AFSs on/off.

The subsection above describes AFSs that are or will soon be flying on satellites. AFSs have characteristics such as lower drift rate and inherent insensitivity to radiation as compared to conventional crystal oscillators and MOGs. It presents examples of space-qualified AFS from several manufacturers.



Figure 11. Rubidium clock for GPS-IIR (courtesy of PerkinElmer).

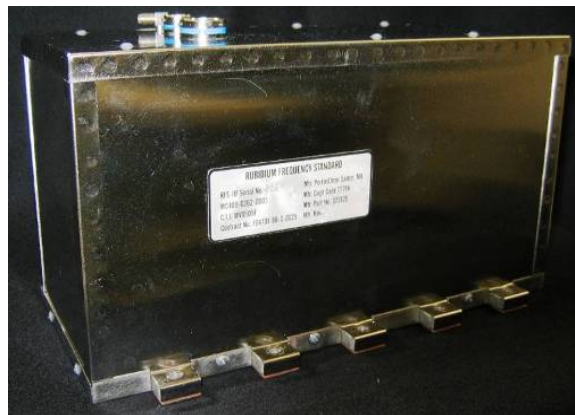

Figure 12. Rubidium clock for GPS-IIF (courtesy of PerkinElmer).

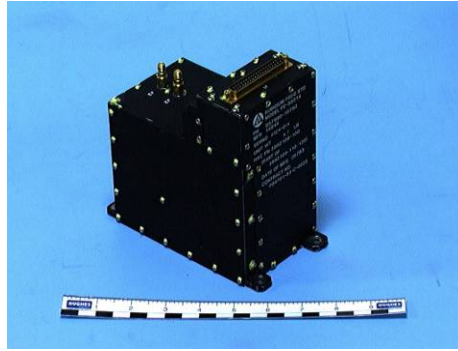

Figure 13. Rubidium clock for Milstar (courtesy of Frequency Electronics).

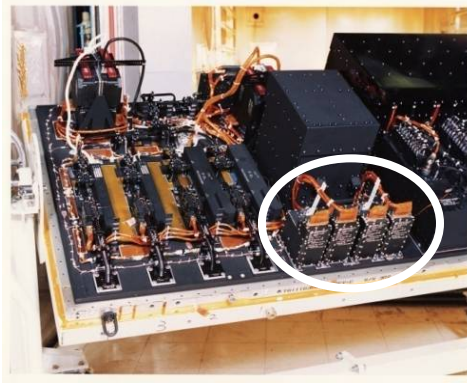

Figure 14. Four installed Milstar rubidium clocks (seen in circle).



Figure 15. Model 4415 digital frequency standard (courtesy of Symmetricom).



Figure 16. Hydrogen maser clock for Galileo GIOVE-B (courtesy of SpectraTime).

CONCLUSIONS

Each piece of flight hardware has many requirement-types that are generic and others that are specific to the hardware function. The two key requirement-types for frequency reference sources are phase noise and stability. Phase noise, coupled with other contributors, decreases signal-to-noise ratios, leads to jitter, degrades BER, generates inter-symbol interference (ISI), leads to earlier loss of lock, and negatively affects acquisition thresholds. Stability is a measure of how much the frequency changes as a function of measurement interval. This paper describes the clock needs for communications and navigation satellites and for scientific space missions. Different satellite needs can be met by crystal oscillators, master oscillator groups, and atomic frequency standards. Crystal oscillators have advantages (small, inexpensive, low mass, low power consumption, fit into a host unit) and disadvantages (are not redundant; require a power supply; have minimal, or no, telemetry and command capability; and are not coherent with each other). A master oscillator is a crystal oscillator that is used as the source for most, or all, frequency references on the satellite. A master oscillator group (MOG) is a group of master oscillators with supporting circuitry. The MOG has characteristics that are significantly different from distributed crystal oscillators. The MOG has centralized multiple crystal oscillators; higher output power; a distribution network with multiple outputs; a power supply; switching for redundancy; extensive telemetry and command capability; and, in some cases, a frequency update capability. MOG may require special isolation for multiple powered oscillators to provide a “hot-backup” capability and for operations during system test. Atomic frequency standards (AFS) are used mostly in navigation satellites, but have found applications in secure communications and scientific missions. AFSs have lower drift rate and inherent insensitivity to radiation when compared to conventional crystal oscillators and MOGs. AFS are preferred for specialized space applications such as navigation, precise timing, and survivability, and for autonomous operations. This paper presents examples of space-qualified crystal oscillators, master oscillator groups, and atomic frequency standards from several manufacturers.

ACKNOWLEDGMENTS

I would like to thank the companies that allowed me to use pictures of their hardware: Frequency Electronics, JHU/APL, PerkinElmer, SpectraTime and Symmetricom. I also wish to give special thanks to Armando Benavides, Richard Greenwald, Charles Mosley, Victor Reinhardt, Thomas Simundich, and Kintak Yue for their helpful discussions on this topic.

REFERENCES

- [1] L. Lewis, 1991, "An introduction to frequency standards," **Proceedings of the IEEE**, **79**, 7.
- [2] J. White and R. Beard, 2002, "*Space clocks—Why they're different*," in Proceedings of the 33rd Annual Precise Time and Time Interval (PTTI) Systems and Applications Meeting, 27-29 November 2001, Long Beach, California, USA (U.S. Naval Observatory, Washington, D.C.), pp. 7-17.
- [3] R. Gagliardi, 1984, **Satellite Communications** (Van Nostrand Reinhold, New York).
- [4] Valpeyfisher, 2007, "*Phase Noise*," www.valpeyfisher.com/glossary.asp, p. 1.
- [5] Modcoinc, 2007, "*Phase Noise*," www.modcoinc.com/glossary.htm, p. 1.
- [6] Wikipedia, 2007, "Phase noise," http://en.wikipedia.org/wiki/Phase_noise, p. 1.
- [7] A. Presser and J. Camparo, 2002, "*Examination of a Crystal Oscillator's Frequency Fluctuations During the Enhanced Space-Radiation Environment of a Solar Flare*," **IEEE Transactions on Nuclear Science**, **49**, 2605-2609.
- [8] J. Vig, 2005, "*Quartz Crystal Resonators and Oscillators - A Tutorial* (U.S. Army Communications-Electronics Research, Development & Engineering Center, Fort Monmouth, New Jersey).
- [9] V. Reinhardt, 2005, "*A Review of Time Jitter and Digital Systems*," in Proceedings of the 2005 Joint IEEE International Frequency Control Symposium and Precise Time and Time Interval (PTTI) Systems and Applications Meeting, 29-31 August 2005, Vancouver, Canada (IEEE Publication 05CH37664C), pp. 38-45.
- [10] B. Elbert, 1999, **Artificial Satellites in Telecommunication** (Artech House, Norwood, Massachusetts).
- [11] W. Hardy, T. McClelland, N. Bhaskar, and L. Mallette, 1995, "*Rubidium Atomic Frequency Standards for the Milstar Satellite Payload*," presented at the AIAA Space Programs and Technologies Conference, 1995, Huntsville, Alabama, USA (American Institute of Aeronautics and Astronautics, Reston, Virginia).
- [12] M. Bloch, J. Ho, T. McClelland, M. Meirs, N. Bhaskar, L. Mallette, and J. Hardy, 1996, "*Performance Data on the Milstar Rubidium and Quartz Frequency Standards: Comparison of Ground Tests in a Simulated Space Environment to Results Obtained on Orbit*," in Proceedings of the 1996 IEEE International Frequency Control Symposium, 5-7 June 1996, Honolulu, Hawaii, USA (IEEE Publication 96CH35935), pp. 1057-1065.
- [13] L. Mallette, P. Rochat, and J. White, 2007, "*Historical Review of Atomic Frequency Standards Used in Satellite Based Navigation Systems*," in Proceedings of the ION 63rd Annual Meeting, 23-25 April 2007, Cambridge, Massachusetts, USA (Institute of Navigation, Alexandria, Virginia), pp. 40-48.
- [14] B. Parkinson and J. Spilker, 1996, **Global Positioning System: Theory and Applications** (AIAA, Washington).

- [15] Y. Takahashi, F. Nakagawa, T. Gotoh, J. Amagai, and S. Hama, 2007, “*Beginning of Precise Time Transfer Experiment using ETS-VIII Satellite,*” in Proceedings of the ION GNSS 2007 Meeting, 25-28 September 2007, Fort Worth, Texas, USA (Institute of Navigation, Alexandria, Virginia), pp. 2039-2042.
- [16] L. A. Mallette, 1982, “*Geostationary Operational Environmental Satellite (GOES): A Multi-functional Satellite.*” Mallette, in Proceedings of the 9th Communications Satellite Systems Conference, March 1982, San Diego, California, USA (American Institute of Aeronautics and Astronautics, Reston, Virginia), pp. 541-547.
- [17] A. McCoubrey, 1996, “*History of atomic frequency standards: A trip through 20th century physics,*” in Proceedings of the 1996 IEEE International Frequency Control Symposium, 5-7 June 1996, Honolulu, Hawaii, USA (IEEE Publication 96CH35935), pp. 1225-1241.
- [18] J. Vig, C. Audoin, L. S. Cutler, M. M. Driscoll, E. P. EerNisse, R. L. Filler, R. M. Garvey, W. J. Riley, R. C. Smythe, and R. D. Weglein, 1992, “*Acceleration, vibration and shock effects – IEEE standards project P1193,*” in Proceedings of the 1992 IEEE Frequency Control Symposium, 27-29 May 1992, Hershey, Pennsylvania, USA (IEEE Publication 92CH3083-3), pp. 763-781.