



**NAVAL
POSTGRADUATE
SCHOOL**

MONTEREY, CALIFORNIA

THESIS

**TRANSFORMING DATA AND METADATA INTO
ACTIONABLE INTELLIGENCE AND INFORMATION
WITHIN THE MARITIME DOMAIN**

by

Joseph J. Sundland
Christopher J. Carroll

June 2008

Thesis Advisor:
Second Reader:

Douglas MacKinnon
Shelley Gallup

Approved for public release; distribution is unlimited

THIS PAGE INTENTIONALLY LEFT BLANK

REPORT DOCUMENTATION PAGE			<i>Form Approved OMB No. 0704-0188</i>	
Public reporting burden for this collection of information is estimated to average 1 hour per response, including the time for reviewing instruction, searching existing data sources, gathering and maintaining the data needed, and completing and reviewing the collection of information. Send comments regarding this burden estimate or any other aspect of this collection of information, including suggestions for reducing this burden, to Washington headquarters Services, Directorate for Information Operations and Reports, 1215 Jefferson Davis Highway, Suite 1204, Arlington, VA 22202-4302, and to the Office of Management and Budget, Paperwork Reduction Project (0704-0188) Washington DC 20503.				
1. AGENCY USE ONLY (Leave blank)		2. REPORT DATE June 2008	3. REPORT TYPE AND DATES COVERED Master's Thesis	
4. TITLE AND SUBTITLE Transforming Data and Metadata into Actionable Intelligence and Information within the Maritime Domain			5. FUNDING NUMBERS	
6. AUTHOR(S) Joseph J. Sundland and Christopher J. Carroll				
7. PERFORMING ORGANIZATION NAME(S) AND ADDRESS(ES) Naval Postgraduate School Monterey, CA 93943-5000			8. PERFORMING ORGANIZATION REPORT NUMBER	
9. SPONSORING /MONITORING AGENCY NAME(S) AND ADDRESS(ES) N/A			10. SPONSORING/MONITORING AGENCY REPORT NUMBER	
11. SUPPLEMENTARY NOTES The views expressed in this thesis are those of the author and do not reflect the official policy or position of the Department of Defense or the U.S. Government.				
12a. DISTRIBUTION / AVAILABILITY STATEMENT Approved for public release; distribution is unlimited			12b. DISTRIBUTION CODE	
13. ABSTRACT (maximum 200 words) At present, the Navy is unable to provide a robust, routable network that provides real-time actionable intelligence between boarding operations and intelligence analysts. Actionable intelligence is the means of obtaining concrete knowledge that permits an individual to take action based on known information. The lack of a robust routable network creates a lag in operational responsiveness to potential threats identified within the Maritime Environment. In response to current shortfalls, improved Extended Maritime Interdiction Operations (EMIO) seeks to support the Secretary of the Navy's vision to streamline and improve operations and exploitation of boarding data. However, there has been no clear indication as to how the implementation of these technologies will affect command and control or current operations. This thesis examines the impact of improved EMIO technology designed to bridge together data with intelligence collected during EMIO and improve maritime domain decision making in terms of speed and quality and thus improve end user's situational awareness. We follow the construct of Business Process Reengineering (BPR) to frame our analysis and to provide focus in our data collection. We also examine the changes to the present EMIO process by developing and implementing an organizational simulation using POWER 2.0. Our results indicate that when improved Spiral-1 EMIO technologies, which significantly decrease the amount of time it takes to fuse collected boarding data into intelligence systems, are combined with a redesign of the EMIO organization, a qualitative improvement toward accomplishing the overall process can be achieved. The current process requires 35 hours. Yet, with the revised technological and proposed organizational changes, the same process can be achieved in 5 hours, thus achieving the Navy Secretary's vision to streamline and improve maritime operations.				
14. SUBJECT TERMS Business Process Reengineering, Leavitt's Diamond, POW-ER, Extended Maritime Interdiction Operations, Maritime Interdiction Operations, Maritime Domain Awareness			15. NUMBER OF PAGES 116	
			16. PRICE CODE	
17. SECURITY CLASSIFICATION OF REPORT Unclassified	18. SECURITY CLASSIFICATION OF THIS PAGE Unclassified	19. SECURITY CLASSIFICATION OF ABSTRACT Unclassified	20. LIMITATION OF ABSTRACT UU	

THIS PAGE INTENTIONALLY LEFT BLANK

Approved for public release; distribution is unlimited

**TRANSFORMING DATA AND METADATA INTO ACTIONABLE
INTELLIGENCE AND INFORMATION WITHIN THE MARITIME DOMAIN**

Joseph J. Sundland
Lieutenant Commander, United States Coast Guard
B.S., United States Coast Guard Academy, 1994

Submitted in partial fulfillment of the
requirements for the degree of

MASTER OF SCIENCE IN INFORMATION TECHNOLOGY MANAGEMENT

Christopher J. Carroll
Lieutenant, United States Navy
B.A., University of New Mexico, 2001

Submitted in partial fulfillment of the
requirements for the degree of

**MASTER OF SCIENCE IN SYSTEMS TECHNOLOGY
(COMMAND, CONTROL, AND COMMUNICATIONS (C3))**

from the

**NAVAL POSTGRADUATE SCHOOL
June 2008**

Authors: Joseph J. Sundland

Christopher J. Carroll

Approved by: Douglas MacKinnon
Thesis Advisor

Shelley Gallup
Second Reader

Dan Boger
Chairman, Department of Information Sciences

THIS PAGE INTENTIONALLY LEFT BLANK

ABSTRACT

At present, the Navy is unable to provide a robust, routable network that provides real-time actionable intelligence between boarding operations and intelligence analysts. Actionable intelligence is the means of obtaining concrete knowledge that permits an individual to take action based on known information. The lack of a robust routable network creates a lag in operational responsiveness to potential threats identified within the Maritime Environment. In response to current shortfalls, improved Extended Maritime Interdiction Operations (EMIO) seeks to support the Secretary of the Navy's vision to streamline and improve operations and exploitation of boarding data. However, there has been no clear indication as to how the implementation of these technologies will affect command and control or current operations. This thesis examines the impact of improved EMIO technology designed to bridge together data with intelligence collected during EMIO and improve maritime domain decision making in terms of speed and quality and thus improve end user's situational awareness. We follow the construct of Business Process Re-Engineering (BPR) to frame our analysis and to provide focus in our data collection. We also examine the changes to the present EMIO process by developing and implementing an organizational simulation using POWER 2.0. Our results indicate that when improved Spiral-1 EMIO technologies, which significantly decrease the amount of time it takes to fuse collected boarding data into intelligence systems, are combined with a redesign of the EMIO organization, a qualitative improvement toward accomplishing the overall process can be achieved. The current process requires 35 hours. Yet, with the revised technological and proposed organizational changes, the same process can be achieved in 5 hours, thus achieving the Navy Secretary's vision to streamline and improve maritime operations.

THIS PAGE INTENTIONALLY LEFT BLANK

TABLE OF CONTENTS

I.	INTRODUCTION.....	1
A.	OVERVIEW	1
B.	MIO/EMIO BACKGROUND.....	3
	1. Authorization.....	3
	2. Mission	4
	3. Command and Control (C2)	5
	a. Command and Control Relationships	7
C.	GEOGRAPHIC BOUNDING.....	8
D.	CURRENT ISSUES AND THESIS INTENT	9
E.	ASSUMPTIONS.....	10
F.	CHAPTER OUTLINE.....	11
II.	ACADEMIC AND TECHNOLOGY REVIEW.....	13
A.	BUSINESS PROCESS REENGINEERING	13
	1. Organizational Norm.....	14
	2. Reengineering.....	15
	3. Organizational Change.....	17
B.	LEAVITT’S DIAMOND	19
	1. Transformation and Application of Leavitt’s Diamond.....	22
C.	POWER MODELING SOFTWARE.....	24
D.	MIO/EMIO SPIRAL-1 TECHNOLOGY.....	25
III.	REENGINEERING EXTENDED MARITIME INTERDICTION OPERATIONS	27
A.	OVERVIEW.....	27
B.	BPR: PHASES I THROUGH III	28
	1. Phase 1: Preparing to Implement.....	28
	2. Phase 2: Map & Analyze ‘As-Is’ Process.....	30
	a. Create Activity Models	32
	b. Create Process Models	33
	c. Simulate and Perform Activity Based Costing.....	34
	d. Identify Disconnects and Value Adding Processes.....	35
	3. Design ‘To-Be’ Processes.....	36
	a. Benchmark the Process	38
	b. Designing the ‘To-Be’ Process	38
	c. Validating the ‘To-Be’ Process.....	40
	d. Performing a Trade-Off Analysis.....	41
IV.	TRANSFORMING DATA INTO ACTIONABLE INTELLIGENCE.....	43
A.	IMPLEMENT REENGINEERED PROCESSES.....	43
B.	APPLYING LEAVITT’S DIAMOND	45
	1. People Solutions	46
	2. Organizational Form Solutions	46

3.	Management Processes	47
C.	NEAR-OPTIMAL EMIO COMMAND AND CONTROL STRUCTURE.....	48
V.	CONCLUSIONS AND RECOMMENDATIONS.....	51
A.	CONCLUSION	51
B.	RECOMMENDED FUTURE RESEARCH.....	53
APPENDIX A.	MDA CONDUCTED INTERVIEWS	55
A.	INTERVIEW WITH THE OFFICE OF NAVAL INTELLIGENCE	55
B.	INTERVIEW WITH NAVAL CENTRAL COMMAND	67
C.	PERCEIVED UTILITY OF MDA SPIRAL 1 TECHNOLOGIES.....	74
D.	LAYOUT OF THE MOC (COPS)	79
APPENDIX B.	WORKFLOW DIAGRAMS	83
A.	WORKFLOW PROCESSES	83
B.	DEPARTMENT OF DEFENSE ARCHITECTURE FRAMEWORK.....	88
	OV-6 Top Level View	88
	ONI Analyst.....	89
APPENDIX C.	MATRIX INSIGHT	91
	LIST OF REFERENCES	93
	INITIAL DISTRIBUTION LIST	97

LIST OF FIGURES

Figure 1.	EMIO/MIO Stages	6
Figure 2.	Modified MIO C2 Structure.....	8
Figure 3.	Phases and Activities of BPR	18
Figure 4.	Task Structure	20
Figure 5.	Leavitt's Diamond	21
Figure 6.	Leavitt's Diamond with Environment	22
Figure 7.	Leavitt's Diamond	24
Figure 8.	TES Overview.....	26
Figure 9.	'Spiral-1' Solutions in Leavitt's Diamond.....	27
Figure 10.	Navy MDA Developmental Flow.....	29
Figure 11.	DoD Architecture Framework MDA Workflow Diagram.....	31
Figure 12.	SAMPLE NAVCENT EMIO C2 Structure	32
Figure 13.	EMIO 'As-Is' POW-ER Model	35
Figure 14.	Operational Capability Alignments with the Fleet CONOPS.....	37
Figure 15.	Spiral-1 Tech Implementation Node Mapping	38
Figure 16.	EMIO 'Spiral-1' Data Paths.....	39
Figure 17.	EMIO 'Spiral-1' POW-ER Model.....	41
Figure 18.	EMIO 'As-Is' Workflow Gantt Chart.....	44
Figure 19.	EMIO 'Spiral-1' Workflow Gantt Chart.....	45
Figure 20.	EMIO 'Near-Optimal' C2 Structure	47
Figure 21.	EMIO 'Near-Optimal' POW-ER Model.....	49

THIS PAGE INTENTIONALLY LEFT BLANK

ACRONYMS AND ABBREVIATIONS

AAR	After Action Report
AO	Area of Operation
AOR	Area of Responsibility
BGAN	Broadband Global Area Network
BO	Boarding Officer
BPR	Business Process Reengineering
BT	Boarding Team
C2	Command and Control
C4I	Command, Control, Communications, Computers, and Intelligence
CENTCOM	Central Command
CFIC	Coalition Forces Intelligence Center
CFT	Cross Functional Team
CGP	Coast Guard Publication
CINCPACFLT	Commander In Chief Pacific Fleet
CIP	Common Intelligence Picture
CJCS	Chairman Joint Chiefs of Staff
CO	Commanding Officer
COCOM	Combatant Commander
COP	Common Operational Picture
COTS	Commercial-Off-The-Self
CPF	Commander Pacific Fleet
DFT	Digital Force Technologies
DHS	Department of Homeland Security
DoD	Department of Defense
DoDAF	Department of Defense Architecture Framework
DOTMLPF	Doctrine, Organization, Training, Material, Leadership and Education, Personnel and Facilities
EMIO	Extended Maritime Interdiction Operations
EXORD	Executive Order
GMCOI	Global Maritime Community of Interest
IO	Intelligence Officer
IT	Information Technology
JIOC	Joint Information Operations Center
MARLO	Maritime Liaison Office
MBET	Maritime BGAN EMIO Terminal
MDA	Maritime Domain Awareness
MHQ	Maritime Headquarters
MIC	Maritime Intelligence Center
MIFCLANT	Maritime Intelligence Fusion Center Atlantic
MIFCPAC	Maritime Intelligence Fusion Center Pacific
MIO	Maritime Interdiction Operations
MOC	Maritime Operational Center

NAG	Northern Arabian Gulf
NAVCENT	Naval Forces Central Command
NCIS	Naval Criminal Investigative Service
NMIC	National Maritime Intelligence Center
NPS	Naval Postgraduate School
NTTP	Naval Tactical Training Publication
ONA	Office Naval Analysis
ONI	Office Naval Intelligence
OPNAV	Office of the Chief of Naval Operations
OPTASK	Operational Tasking
OTC	Officer in Tactical Command
PACOM	Pacific Command
PEO	Program Executive Office
PEW	Process Engineering Workshop
RFI	Request for Information
ROMO	Range of Military Operations
SECDEF	Secretary of Defense
SPAWAR	Space and Naval Warfare
TED	Tactical EMIO Device
TEMP	Tactical EMIO Maritime PC
TES	Tactical EMIO System
UNSC	United Nations Security Council
USCG	United States Coast Guard
USN	United States Navy
VBSS	Visit, Board, Search, Seizure
VHF	Very High Frequency
VOI	Vessel of Interest

LIST OF TABLES

Table 1.	EMIO ‘As-Is’ Workflow Matrix.....	34
Table 2.	EMIO ‘As-Is’ Workflow Results.....	36
Table 3.	EMIO Spiral-1 ‘To-Be’ Matrix.....	39
Table 4.	EMIO Spiral-1 ‘To-Be’ Workflow Results	42
Table 5.	EMIO ‘Near-Optimal’ Matrix.....	48
Table 6.	EMIO ‘Near-Optimal’ Workflow Results	50

THIS PAGE INTENTIONALLY LEFT BLANK

ACKNOWLEDGMENTS

We would like to thank Dr. Douglas MacKinnon and Dr. Shelley Gallup for your continuous dedication and devotion to our academic journey. Your support and guidance made our thesis experience here at Naval Postgraduate worthwhile. We would also like to thank the outstanding group of patriots working on the Secretary of the Navy's MDA prototype. In particular, we would like to thank Christine Barton and Aaron Ross of Space and Naval Warfare System Center, San Diego and Charleston for their professionalism and assistance in support of this thesis.

LCDR Joseph J. Sundland

To my wife Melinda, thank you for all your support and patience during the past six months.

To Chris, my thesis partner, thank you for your wisdom and EMIO experience that we relied upon for guidance throughout this thesis, and thank you for the many discussions about the ins and outs of political science...it is a wonder we finished our thesis before graduation.

LT Christopher J. Carroll

To my wife Arianne, thank you for all your support throughout this process. Your love and devotion have not been unnoticed.

To my children, Brelin and Sydney, thank you for sacrificing your time with Daddy.

To Joe, my thesis partner, thank you for your hard work and steady focus throughout this thesis process. Your positive attitude and great sense of humor made this an enjoyable experience.

THIS PAGE INTENTIONALLY LEFT BLANK

I. INTRODUCTION

A. OVERVIEW

Maritime Domain Awareness (MDA) is a National Security concept that relies on the aggregate capabilities of multiple government agencies such as the Department of Defense (DoD) and Department of Homeland Security (DHS), as well as other federal, state, and local agencies in order to achieve comprehensive situational awareness of any threat associated within the Maritime Domain. The National Plan to Achieve Maritime Domain Awareness (October 2005) defined the Maritime Domain as “all areas and things on, under, relating to, adjacent to, or bordering on a sea, ocean, or other navigable waterway, including all maritime-related activities, infrastructure, people, cargo, and vessels and other conveyances.” Furthermore, the National Plan identifies Nation-state, terrorist, transnational criminal and piracy, and environmental and social threats within the Maritime Domain. In order to address these threats, the National Plan lists the following tasks to meet the requirement:

- Persistently monitor in the global maritime domain:
 - Vessels and craft
 - Cargo
 - Vessel crews and passengers
 - All identified areas of interest
- Access and maintain data on vessels, facilities, and infrastructure.
- Collect, fuse, analyze, and disseminate information to decision makers to facilitate effective understanding.
- Access, develop and maintain data on MDA-related mission performance.

The National Concept of Operations for MDA (August 2007) provides a foundation for developing interagency and agency-specific policies, processes,

procedures, and organizational relationships to align activities that contribute to achieving MDA throughout the Global Maritime Community of Interest (GMCOI).

The Department of Defense, following guidance set forth from the National Concept of Operations for MDA, developed the Fleet Concept of Operations for Maritime Domain Awareness (13 March 2007) and the Navy MDA Concept (29 May 2007), which describe the Fleet role in MDA and how Fleet commanders will develop and maintain MDA to accomplish Navy missions across the full Range of Military Operations (ROMO).

In a memorandum dated 17 May 2007, the Secretary of the Navy directed the fielding of a prototype MDA capability by August 2008, and established a Cross Functional Team (CFT) to oversee the effort. The memorandum directs the following end state:

1. Begin fielding an enduring operational MDA capability.
2. The first Spiral¹ will provide:
 - a. A capability to the U.S. Central Command (CENTCOM) and U.S. Pacific Command (PACOM) Areas of Responsibilities (AORs), interagency partners, and select friendly and allied nations.
 - b. The core effort will create a network that, at multiple levels of security and across multiple domains, will feed many data streams into a common operational picture (COP) accessible throughout the United States Government and foreign or Coalition partners.
 - c. Be able to handle time sensitive maritime threats.
 - d. Will be designed for expansion.

¹ Spiral Development. In this process, a desired capability is identified, but the end-state requirements are not known at program initiation. Those requirements are refined through demonstration and risk management; there is continuous user feedback; and each increment provides the user the best possible capability. The requirements for future increments depend on feedback from users and technology maturation. (<https://acc.dau.mil/CommunityBrowser.aspx?id=24421>).

3. The effort will be used to resolve or develop new policy and procedures for MDA.
4. Subsequent spirals will extend this capability and add functionality.²

The Deputy Chief of Naval Operations (Communication Networks) (N6) and Acting Deputy Under Secretary of the Navy (DUSN) were designated as co-chairs of the MDA CFT. The Assistant Secretary of the Navy (Research, Development, & Acquisition) (ASN (RDA)) designated the Space and Naval Warfare Center's (SPAWAR) Program Executive Office for Command, Control, Communications, Computers and Intelligence (PEO C4I) as the Acquisition Lead for delivery of the SECNAV's MDA Prototype.

It is the goal of this thesis to examine Maritime Interdiction Operations (MIO) and Extended Maritime Interdiction Operations (EMIO) as a subset of MDA and evaluate how MDA Prototype MIO/EMIO technologies impact this mission. Chapter 1 provides background information regarding MIO/EMIO governance and application, current efforts to improve MIO/EMIO capabilities with Spiral 1 technologies, and the academic framework utilized to support thesis analysis.

B. MIO/EMIO BACKGROUND

1. Authorization

According to the Maritime Interception Operations Manual (Navy Tactical Training Publication (NTTP)/Coast Guard Publication (CGP) 3-07.11), Maritime Interdiction Operations are the legitimate actions taken by the United States Navy and Coast Guard, Coalitional Partners, and Allies to interdict "suspect vessels to determine if they are transporting goods or persons prohibited by the sanctioning agency to or from a specific nation, nations, or non-state sponsored organizations." Authorization to conduct Maritime Interdiction Operations is based on international law and is given by the United Nations Security Council (UNSC), national authority, or other regional authority.

² "Scoping Document for Navy Maritime Domain Awareness (MDA) Spiral 1 Prototype," Revised January 2008 – Version 4.3.

Extended Maritime Interdiction Operations target personnel or material that poses an imminent threat to the United States. Extended Maritime Interdiction Operations are authorized by the Secretary of Defense (SECDEF) and may involve multinational forces and may be implemented without sanctions. Chairman, Joint Chiefs of Staff (CJCS) Executive Order (EXORD) and combatant commander and fleet commander's operational tasking (OPTASK) provide EMIO guidance.

Both operations, MIO and EMIO, are the act of interdicting suspect vessels and used to positively inspect, detect, identify, warn, and report the presence of prohibited items in seagoing vessels. As such, for the intended purposes of this thesis, MIO and EMIO will be used interchangeably with the understanding that they share the same execution process; and the term Extended Maritime Interdiction Operations will be used to imply both missions. Furthermore, tasked units, such as U.S., Coalition, and Allied vessels execute EMIO by utilizing their Visit, Board, Search, and Seizure (VBSS) teams.

2. Mission

Extended Maritime Interdiction Operations (EMIO) are part of a larger mission conducted under Visit, Board, Search, and Seizure (VBSS). MIO utilizes VBSS teams, also known as Boarding Teams (BT), to approach, board, secure, and search all types of vessels. There are different types of Maritime Interdiction Operations that vary from a totally compliant environment to a situation that erodes quickly towards noncompliance and threats of, or actual, hostile acts as articulated in Maritime Interception Operations Manual NTTP 3-07.11. Some of the actions taken during EMIO may include:

1. Sending armed boarding teams to visit merchant ships bound to, through, or out of a defined area.
2. Examining each ship's papers and cargo.
3. Searching for evidence of contraband.
4. Diverting vessels failing to comply with the guidelines set forth by the sanctioning body.

5. Seizing suspect vessels and their cargo that refuse to divert.

For the intended purposes of this thesis, standard or routine boarding operations which consist of vessel of interest (VOI) compliance and safe and secure embarkation of boarding team members will be used to bound MIO analysis.

3. Command and Control (C2)

The Joint Chiefs of Staff Publication 1 defines Command and Control (C2) as the act of “effectively using available resources, planning the employment of, organizing, directing, coordinating, and controlling military forces for the accomplishment of assigned missions.” This process, as it applies to Extended Maritime Interdiction Operations (EMIO), can be broken up into two stages. The first stage consists of threat identification, mission planning, and asset allocation. Threat identification is a function normally performed by intelligence centers. Intelligence centers provide MIO support by supplying the MIO commander with vessel descriptions, location data, and other intelligence support. The MIO Commander (MIC) utilizes the information provided from the intelligence centers to conduct planning and asset allocations in support of MIO. Once a vessel of interest is identified, the asset or On-Scene Commander (OSC) interdicting the VOI will begin planning for boarding operations.

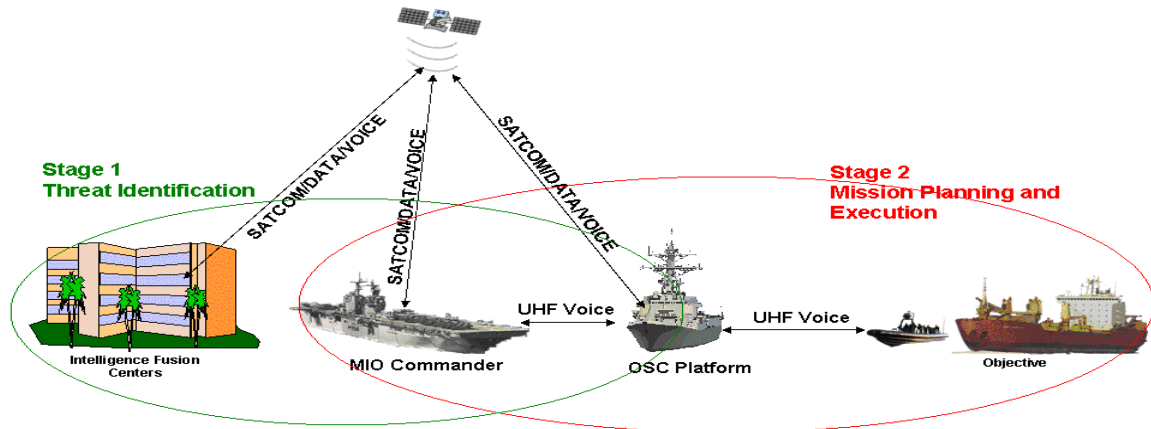

Figure 1. EMIO/MIO Stages

The second stage is the boarding stage. In this stage the OSC intercepts the VOI and coordinates assets in order to conduct a boarding. The OSC deploys his VBSS team which embarks the vessel of interest and collects data in support of the MIO mission. These stages are illustrated in Figure 1.³ NTTP 3-07.11 identifies the essential elements of information to be collected by boarding teams as follows:

1. Cellular phone numbers
2. Ship's registration
3. Crew information
4. Owner's information
5. Managing company information
6. Agent/broker information
7. Communications and navigation information

³ Space and Naval Warfare MDA Prototype Working Group. "White paper on MIO/EMIO Requirements overview and vision as applied to SECNAV MDA Prototype Effort," Draft 2007.

8. Master's safe
9. Personal documents
10. Ship's logs
11. Ship's cargo and cargo manifest
12. Financial data and movement history
13. Bill of sale and legal documents
14. Smuggling activity information
15. Status of the ship's material condition.

More information may be gathered in support of additional intelligence collection requirements, theater guidance, or specific collection goals. Furthermore, the type of data collected consists of a mix of textual and imagery data. In specific cases biometric data collection may be required but is not addressed within this thesis.

a. Command and Control Relationships

MIO Operational Command and Control can vary in size depending on the Area of Operation (AO), size of the MIO force, and the political objectives of the mission. The geography of the AO significantly impacts the size of the MIO force required and the amount of decentralization within the C2 structure. Figure 2 illustrates a basic MIO C2 structure.⁴

⁴ Naval Tactical Training Publication (NTTP) 3-07.11, "Maritime Interception Operations," November 2003.

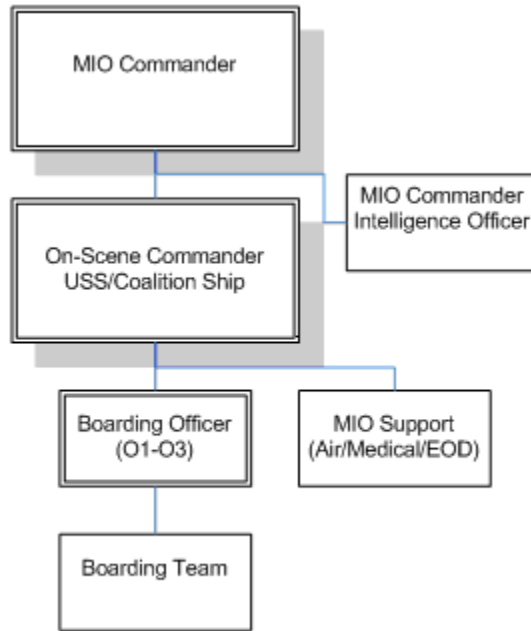

Figure 2. Modified MIO C2 Structure

The MIO Commander (MIC) is the officer in tactical command (OTC) of the forces assigned to conduct MIO. The MIC through the efforts of his Intelligence Officer (IO) ensures that the On-Scene Commander (OSC) is provided with information on the concerned VOI. The OSC is the Commanding Officer (CO) attached to the intercepting vessel and is charged with the coordinating functions necessary to conduct the MIO. The Boarding Officer leads boarding team efforts on the VOI and reports directly to the OSC.⁵

C. GEOGRAPHIC BOUNDING

This analysis of Maritime Interdiction Operations will be geographically bounded within CENTCOM's AOR. Within CENTCOM, Naval Central Command (NAVCENT) is the responsible service component charged with executing Maritime Operations. Within NAVCENT, the Coalition Forces Intelligence Center (CFIC) is the

⁵ Naval Tactical Training Publication (NTTP) 3-07.11, "Maritime Interception Operations," November 2003.

primary user group responsible for EMIO. The Office of Naval Intelligence (ONI) is an inorganic entity and key player in supporting the overall MIO mission.

D. CURRENT ISSUES AND THESIS INTENT

Currently NAVCENT is unable to provide a robust routable network that provides near real-time actionable intelligence between boarding operations and intelligence analysts at CFIC. *Actionable intelligence*, as defined here, is the means of obtaining concrete knowledge that permits an individual to take action based on known information. *Routable* refers to information that can be packetized and transmitted over some sort of communications medium, and near real-time is constrained within the time it takes to complete an average boarding.

According to CFIC operators, the primary issues that they must overcome include: “the inability of interdiction teams to access recent boarding information and historical information about a vessel, the ability for the CFIC analyst to get access to the images and other data captured during a boarding in a timely manner, the ability of CFIC and/or interdiction teams to enter boarding data (including imagery) into intelligence systems, and the need for automated and bandwidth friendly distribution of new boarding data to all users who need it.”⁶

The lack of timely integration of collected boarding data being entered into intelligence systems in order to be analyzed by intelligence officers creates a lag in operational responsiveness to potential threats identified within the Maritime Environment. This delay in information processing significantly hinders boarding team activities in cases where information gathered and analyzed may have resulted in seizing a vessel or detaining a person or persons of interest. This shortfall has provided motivation for MDA Spiral-1 technologies to be identified that improve Maritime Interdiction Operations by streamlining procedures in order to exploit collected boarding data. However, there has been no clear indication as to how the implementation of these technologies will affect EMIO command and control or current operations.

⁶ Space and Naval Warfare MDA Prototype Working Group, “White paper on MIO/EMIO Requirements overview and vision as applied to SECNAV MDA Prototype Effort ,” Draft 2007.

MDA and MIO/EMIO Spiral 1 efforts are being driven by a vision for enhancing the operations and exploitation of boarding data. The desired goal or improved business process for MIO is to reduce the time it takes collected boarding data to be transmitted and made available to users within the appropriate intelligence fusion centers for analysis and redistribution. Current prototype efforts have procured specific IT capabilities designed to improve this process, but the impact that the changes in IT will bear on the people involved in the process and the organizations performing the mission is unknown.

The focus of this thesis is to examine the impact of Spiral-1 EMIO technologies designed to seamlessly fuse automated boarding data into intelligence systems with the intent of improving maritime domain decision making in terms of speed and quality and improve the intelligence analyst's and boarding officer's situational awareness. Examination will be performed by analyzing Spiral-1 EMIO efforts within the construct of Business Process Reengineering wrapped within the framework of Leavitt's Diamond. Furthermore, EMIO organizational simulation in POW-ER 2.0 will produce both qualitative and quantitative data regarding the benefit or lack of benefit gained from MDA MIO/EMIO Spiral-1 technologies. Therefore, we seek to answer the following two thesis questions:

1. How will Spiral-1 technologies impact the command and control process for Extended Maritime Interdiction Operations?
2. What is the near-optimal Extended Maritime Interdiction Operations command and control structure after Spiral-1 technology implementation?

E. ASSUMPTIONS

1. The Navy's MDA Concept, Fleet MDA Concept, Scoping Document for Navy Maritime Domain Awareness Spiral-1 Prototype, and White paper on MIO/EMIO Requirements overview and vision as applied to SECNAV MDA Prototype Effort are guiding documents.
2. Scoping Document for Navy Maritime Domain Awareness Spiral-1 Prototype and White paper on MIO/EMIO Requirements overview and vision as applied

to SECNAV MDA Prototype Effort are currently in draft form but will be approved by August 2008.

3. MDA implementation will be achieved through a spiral development process.
4. Spiral-1 capabilities will concentrate on the management, correlation, and distribution of vessel data, focusing on the capabilities deliverable by August 2008.
5. Spiral-1 capabilities will meet threshold requirements only.
6. Spiral-1 will utilize Intelligence, Surveillance, and Reconnaissance (ISR) collection sensors and means already deployed or programmed.
7. The Office of Naval Intelligence (ONI) will serve as the center of excellence for all-source maritime intelligence fusion within the Global Maritime Community of Interest.
8. Migration to a Services Oriented Architecture (SOA) with applicable multi-level security, user-defined operational picture, and other enabling services will continue.
9. The POW-ER (2.0) model simulations (discussed below) are a working model that use approximate durations for the activities due to their dynamic nature.

F. CHAPTER OUTLINE

Chapter II of this thesis will provide an academic and technology review of Business Process Reengineering (BPR), Leavitt's Diamond, POW-ER 2.0, and Spiral-1 MIO/EMIO technologies. Chapter III will evaluate the impact of MIO/EMIO Spiral-1 technologies on Maritime Interdiction Operations and provide the answer for thesis question 1. Chapter IV will continue analysis of MIO/EMIO Spiral-1 efforts and answer thesis question 2. Chapter V will conclude this thesis and provide recommendations for future research.

THIS PAGE INTENTIONALLY LEFT BLANK

II. ACADEMIC AND TECHNOLOGY REVIEW

A. BUSINESS PROCESS REENGINEERING

The Industrial Age ushered in a tremendous change in the way companies were built and how they developed products. Adam Smith discovered that industrial work should be broken down into its simplest and most basic tasks.⁷ However, the world is currently changing and has changed in many different ways due to the rapid innovation of technology and information systems, which brings us into the Information Age. Many organizations have undertaken myriad initiatives to improve their performances to keep pace with increasing global demand, competition, and changing technologies. Those initiatives include redesign and/or incremental changes to their business processes. This new Information Age is dictating a new and different way of maintaining and achieving that competitive advantage over the competitor. However, many large successful organizations were developed on the premise from the Industrial Age, which can be summed the larger the organization, the more specialized is the worker, and the more separate the steps into which the work is fragmented.⁸

The growing number of people in middle management within the military services and government agencies were one of the costs organizations paid for the benefits of fragmenting their work into simple, repetitive steps and organizing themselves hierarchically. Another cost was the increasing distance that separated senior management from users of their product or service.⁹ These are the roots of today's corporations, military services and government agencies, and the principles, forged by necessity, upon which today's companies have structured themselves. If modern organizations structured their work tasks into small pieces, it is because that is how efficiency was once achieved. If they diffuse power and responsibility through massive

⁷ Michael Hammer and James Champy, *Reengineering the Corporation: A Manifesto for Business Revolution* (London: Nicholas Brealey Publishing, 1995), 35.

⁸ *Ibid.*, 12.

⁹ *Ibid.*, 16.

bureaucracies, it is because that was the way they learned to control sprawling enterprises.¹⁰ Their resistance to change the way they operate was supported by their very own success in how the organization conducted business.

1. Organizational Norm

Where and when do you begin to change the way your organization or agency does business in order to gain or maintain the competitive advantage? At the heart of reengineering is the notion of discontinuous thinking of recognizing and breaking away from the outdated rules and fundamental assumptions that underlie operations.¹¹ Organizations cannot achieve breakthroughs in performance by simply eliminating excess fat or automating current processes; instead, the companies also need to challenge the current rules and assumptions that have led the company to under perform in the first place. Every business is replete with implicit rules that remain from earlier decades.¹² These rules are based on assumptions about processes, technology, people, and organizational goals that no longer hold true. Information and innovative technology is vast and quickly expanding. Quality, innovation, and service are now more important than cost, growth, and control. A large portion of the population is educated and capable of assuming responsibility, and workers cherish their autonomy and expect to have a say in how the business is run.¹³ It should be no surprise that our military processes and structures are outdated, and the work structures and processes have not kept pace with the fast pace of innovative technology, demographic changes, and military objectives. This arrangement can be traced to the Industrial Revolution, when specialization of labor and economies of scale promised to overcome the inefficiencies of cottage industries where businesses disaggregated work into narrowly defined tasks, re-aggregated the people

¹⁰ Michael Hammer and James Champy, *Reengineering the Corporation: A Manifesto for Business Revolution* (London: Nicholas Brealey Publishing, 1995), 17.

¹¹ Michael Hammer, "Reengineering Work: Don't Automate, Obliterate." *Harvard Business Review* (July-August 1990), 107.

¹² *Ibid.*, 107.

¹³ *Ibid.*

performing those tasks into departments, and installed managers to administer them.¹⁴ Many companies over the past few decades have tried to change the way they conduct business or implement drastic changes into their processes; unfortunately most of them have failed to improve their overall performance.

2. Reengineering

“Reengineering is the fundamental rethinking and radical redesign of business processes to achieve dramatic improvements in critical, contemporary measures of performance, such as cost, quality, service, and speed.”¹⁵ The reengineering definition contains four key words that are critical to the success of this concept, which are *fundamental*, *radical*, *dramatic*, and *processes*. *Fundamental* refers to two basic questions about the organization and how they operate: Why do we do what we do and Why do we do it the way we do? When organizations ask these fundamental questions, it forces the management and workers to look at the rules and assumptions that bring about the way they conduct their business. More than often, these rules or assumptions turn out to be erroneous or irrelevant. Reengineering begins with no assumptions and no givens, and companies must guard against the assumptions that most processes already have embedded in them. Reengineering first determines what a company must do, then how to do it, and it takes nothing for granted as it ignores what is and concentrates on what should be.¹⁶

The second key word in the definition is radical, which refers to the radical redesign of getting to the root of things: not making superficial changes or *fiddling* with what is already in place, but throwing away the old. In reengineering, radical redesign means disregarding all existing structures and procedures and inventing completely new

¹⁴ Michael Hammer, “Reengineering Work: Don’t Automate, Obliterate.” *Harvard Business Review* (July-August 1990), 107.

¹⁵ Michael Hammer and James Champy, *Reengineering the Corporation: A Manifesto for Business Revolution* (London: Nicholas Brealey Publishing, 1995), 32.

¹⁶ *Ibid.*, 33.

ways of accomplishing work. Reengineering is about business reinvention-not business improvement, business enhancement, or business modification.¹⁷

The third key word is *dramatic*, which focuses on making quantum leaps in performance, not making incremental or marginal improvements. Companies looking for minor improvements in their bottom line or performance do not need reengineering. However, reengineering should be used when companies need dramatic change. Hammer and Champy have identified three kinds of companies that undertake reengineering. First are companies that need order-of-magnitude improvement with costs, services or quality. Second are companies that are not yet in trouble, but whose management has the foresight to see trouble in the future, so these companies will use reengineering in advance of running into adversity. The third type of company is those that are excelling and have no difficulties on the horizon, but their managements are ambitious and aggressive. These companies will use reengineering as an opportunity to enhance their performance to achieve a greater competitive advantage over their competitor.¹⁸

The fourth key word in the definition is *processes*, and it is the most important, but also gives corporate managers the most difficulty. Most businesspeople are not “process-oriented;” they are focused on tasks, on jobs, on people, on structures, but not on processes.¹⁹ Hammer and Champy define business process as a collection of activities that takes one or more kinds of input and creates an output that is of value to the customer. The individual tasks within a process are important; however, none of them matter if the overall process doesn’t work because it doesn’t deliver the product or service.

¹⁷ Michael Hammer and James Champy, *Reengineering the Corporation: A Manifesto for Business Revolution* (London: Nicholas Brealey Publishing, 1995), 33.

¹⁸ *Ibid.*, 34.

¹⁹ *Ibid.*, 35.

3. Organizational Change

Reengineering requires focuses on processes and not be limited to thinking about organizations, which the organization is only as effective as its processes. ²⁰ Process mapping provides tools and a proven methodology for identifying your current ‘As-Is’ business processes and can be used to provide a ‘To-Be’ roadmap for reengineering your product or service business enterprise functions. It is the critical link that your reengineering team can apply to better understand and significantly improve your business processes and bottom-line performance.²¹ Muthu, Whitman, and Cheraghi provide ‘best of breed’ methodologies from contemporary literature and introduce a consolidated, systematic approach for Business Process Reengineering, which includes five activities shown in Figure 3: Prepare for Reengineering, Map and Analyze As-Is process, Design To-Be process, Implement reengineered process, and Improve continuously. ²²

²⁰ Michael Hammer and James Champy, *Reengineering the Corporation: A Manifesto for Business Revolution* (London: Nicholas Brealey Publishing, 1995), 348.

²¹ Subramanian Muthu, Larry Whitman, and S. Hossein Cheraghi, “Business Process Reengineering: A Consolidated Methodology,” *Proceedings of the 4th Annual International Conference on Industrial Engineering Theory, Applications and Practice* (November 1999), 1-5.

²² *Ibid.*, 3.

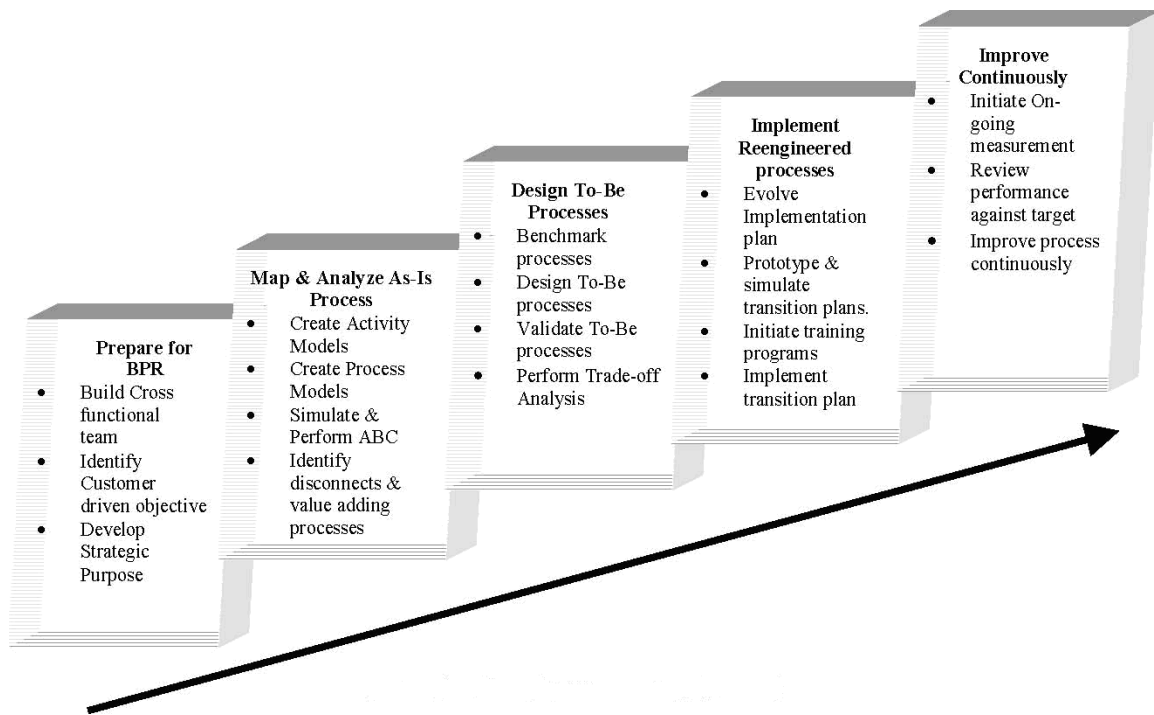

Figure 3. Phases and Activities of BPR

The five activities provided in Figure 3 are not a quick fix for a successful BPR initiative, but provide a framework which involves an intense customer focus, superior process design and a strong motivated leadership each of which are vital ingredients to the recipe for the success of any business corporation.²³

Those aspiring to improve the way work is done must begin to apply the capabilities of information technology to redesign business processes. Business process redesign and information technology are natural partners and create a new type of industrial engineering, changing the way the discipline is practiced and the skills necessary to practice it.²⁴ Information Technology should be viewed as more than an automating or mechanizing force; it can fundamentally reshape the way business is done. Business activities should be viewed as more than a collection of individual or even functional tasks; they should be broken down into processes that can each be redesigned

²³ Thomas H. Davenport and James E. Short, "The New Industrial Engineering: Information Technology and Business Process Resign." *Sloan Management Review* (Summer 1990), 11-13.

²⁴ *Ibid.*, 11.

for maximum effectiveness, in both manufacturing and service environments.²⁵ Business processes were redesigned across enterprise to take advantage of information technology and the Internet, and because of this new concept, there is another concurrent approach to business process improvement taking shape based on more effective knowledge-based business transformation.²⁶ Therefore, the Internet allows organizations or enterprises to communicate instantly with customers, stakeholders, and partners, and it has changed the way information can move across enterprises, the way business transactions are carried out, and the way relationships are nurtured and maintained. Business Process Reengineering (BPR) is carried out, alternatively, in an organizational context that has people, technologies, and organizational form and structure.²⁷

B. LEAVITT'S DIAMOND

The late Stanford Professor, Harold J. Leavitt, was an organizational theorist who claimed that industrial organizations could be viewed “as complex systems in which at least four interacting variables loom especially large; task variables, structural variables, technological variables, and human variables.”²⁸ Leavitt described the four variables as follows:

- *Task* – refers to industrial organizations: the production of goods and services, including the large numbers of different but operationally meaningful subtasks that may exist in complex organizations.
- *Actors* – refers chiefly to people, but with the qualification that acts executed by people at some time or place need not remain exclusively in the human domain.

²⁵ Thomas H. Davenport and James E. Short, “The New Industrial Engineering: Information Technology and Business Process Resign.” *Sloan Management Review* (Summer 1990), 12.

²⁶ Omar A. El Sawy, *Redesigning Enterprise Processes for e-Business* (New York: McGraw Hill Irwin, 2001), 7.

²⁷ *Ibid.*, 7.

²⁸ Harold J. Leavitt, “Applied Organizational Change in industry: Structural, Technological and Humanistic Approaches” *Handbook of Organizations*, (Chicago: Rand McNally, 1965), 1144-1170.

- *Technology (Information and Control)* – refers to direct problem-solving inventions like work-measurement techniques or computers or drill presses.
- *Structure* – means systems of communication, systems of authority, and systems of work.²⁹

Leavitt also observed that any approach to organizational change could differ depending on which variable one chose to apply change throughout an organization. For example, if the task of an organization is to improve efficiency then one could argue to change structural solutions, information and control solutions, or people solutions or change all three in order to achieve that task. Figure 4 illustrates how the different solutions for improving efficiency are related to the variable task.³⁰

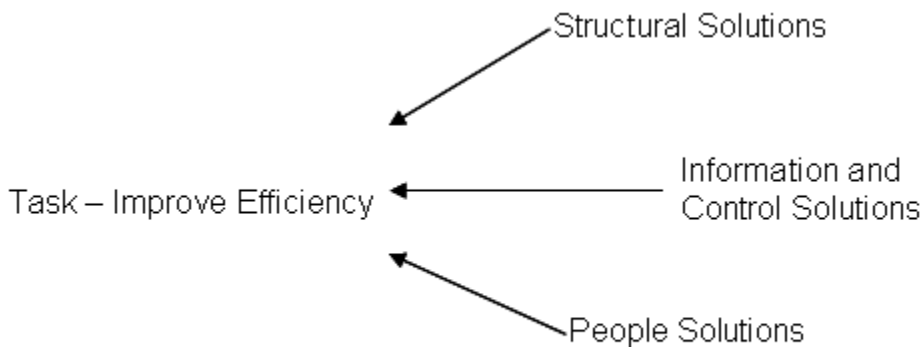

Figure 4. Task Structure

Regardless of the solution chosen, Leavitt recognized that none were mutually exclusive. Therefore, if one solution was chosen to improve the variable task, it could not be implemented without having an affect on the other variable. Thus, Leavitt ducted that all four organizational variables are highly interdependent and that change in any one

²⁹ Harold J. Leavitt, “Applied Organizational Change in industry: Structural, Technological and Humanistic Approaches” *Handbook of Organizations*, (Chicago: Rand McNally, 1965), 1144-1170.

³⁰Harold J. Leavitt, *Managerial Psychology* (Chicago: The University of Chicago Press, 1978), 284.

usually results in compensatory change in others.³¹ This relationship is illustrated in Leavitt's Diamond, shown in Figure 5, in which the arrows indicate the interdependence amongst variables.³²

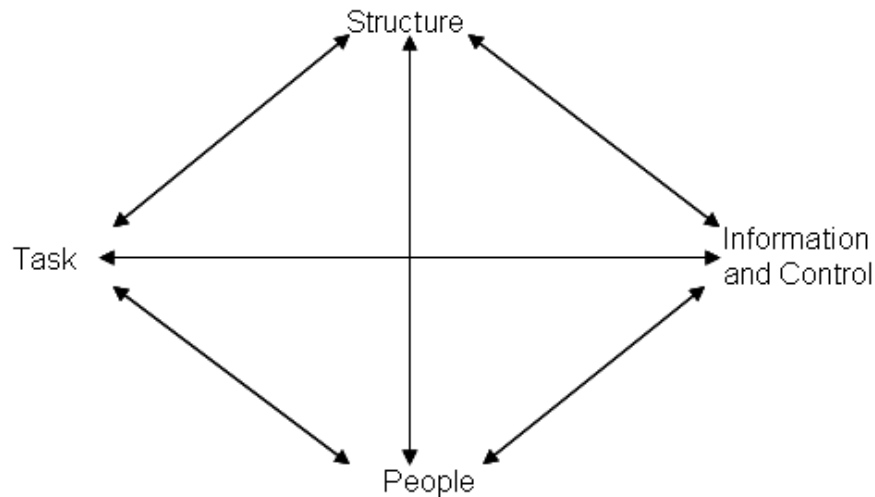

Figure 5. Leavitt's Diamond

Since the inception of Leavitt's Diamond, environmental factors have had a major influence on the way organizations operate. Professor Leavitt recognized this and that organizations do not exist in a vacuum and therefore, the Leavitt Diamond was not complete as shown above. Instead, organizations exist in a dynamic world in which the environment that they operate in is constantly changing and has an overall affect on the organization as a whole. Thus, the application of the environment to Leavitt's Diamond, as shown in Figure 6, completes his organizational model.³³

³¹ Harold J. Leavitt, "Applied Organizational Change in industry: Structural, Technological and Humanistic Approaches" *Handbook of Organizations*, (Chicago: Rand McNally, 1965), 1145.

³² Harold J. Leavitt, *Managerial Psychology* (Chicago: The University of Chicago Press, 1978), 286.

³³ *Ibid.*, 287.

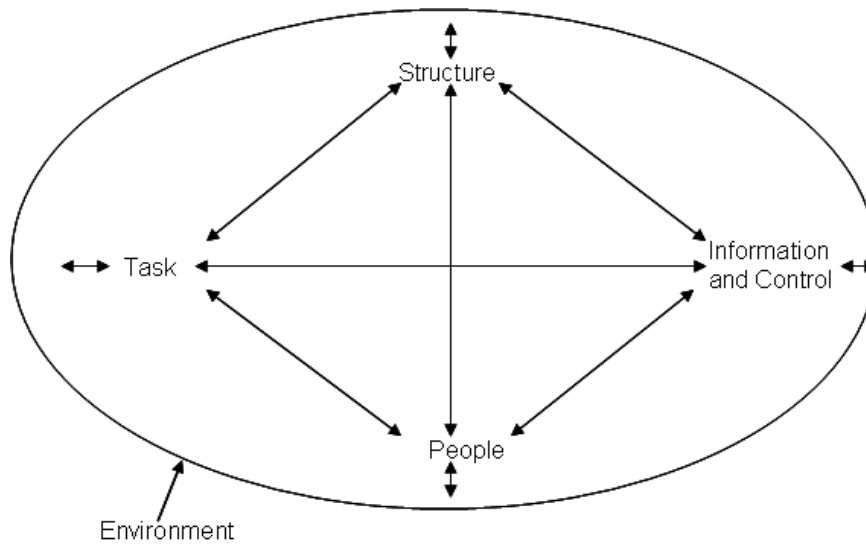

Figure 6. Leavitt's Diamond with Environment

1. Transformation and Application of Leavitt's Diamond

In thinking in broader terms, one could not ignore the contrasts between the Industrial and Information Age in order to see that environmental factors are the driving change. There are many environmental factors that have had major influences on the way organizations operate and have caused slight modifications to the model in order to maintain applicability. For example, race and gender issues affected organizations in the 60s and 70s, whereas now information technology and supply-chain management greatly affect businesses today as well as for the past 10 years. Leavitt's Diamond has evolved since its conception to incorporate these significant environmental changes.

Organizations today must be able to adapt to a rapidly changing environment and global economy and quickly implement change to their organizational structure and/or processes in order to gain and maintain a competitive advantage. During the Industrial Age, the 'task' a business performed usually held management's attention and achieved the desired affect until the environment changed, which slowly occurred over several decades. Whereas in the Information Age, 'business processes' that focused on how tasks were performed now dominate the way businesses are conducted and need to be easily changed due to the rapidly changing environment. Technology continues to be the direct

problem solving invention for accomplishing tasks through automation. Therefore, ‘Information Technology’, which consists of hardware, software, networks, and workstations³⁴, has revolutionized the way Industrial Aged activities were once performed. Industrial Aged ‘structural’ controls are becoming or have become obsolete and are being replaced by new ‘organizational forms’ that take advantage of today’s rapidly changing environment. ‘Actors or People’ during the Industrial Age could perform a wide range of jobs that required low skill; whereas today, people with requisite skills are needed to maintain a competitive ‘workforce’. Lastly, in today’s environment where large corporations are globally distributed, an additional variable needs to be added to Leavitt’s Diamond. This variable ‘management process’ pertains to how top management distributes its vision for change throughout the full breadth of its organization.³⁵ Management process plays a key role in the success or failure of any organization and its ability to adapt and implement change.³⁶ The transformation of Leavitt’s Diamond from the Industrial Age to the Informational Age and how it will be applied throughout this thesis is presented in Figure 7.

³⁴ Michael S. Scott Morton, *The Corporation of the 1990s* (New York and Oxford: Oxford University Press, 1991), 244.

³⁵ *Ibid.*, 244.

³⁶ *Ibid.*, 245.

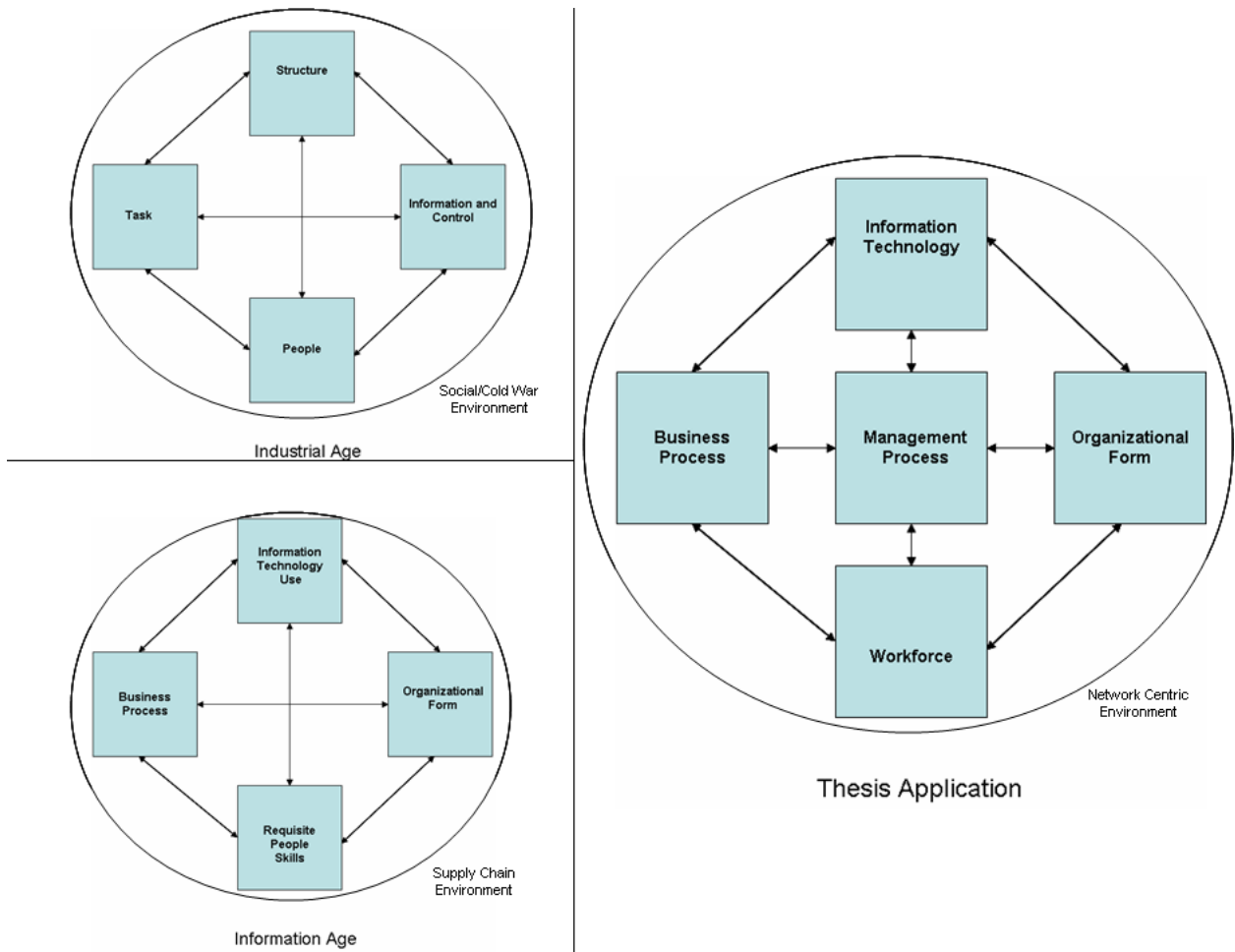

Figure 7. Leavitt's Diamond

C. POW-ER MODELING SOFTWARE

In order to capture and document the ‘As-Is’ and ‘To-Be’ process for the EMIO workflow, we will use POW-ER, which is modeling software developed by the Civil Engineering Department at Stanford University. This model attempts to develop a computational model of project organizations to analyze how activity interdependencies raise coordination needs and how organization design and introduction of communication tools may change the coordination capacity of project teams, with resulting impacts on

project performance. POW-ER was built based on organizational contingency theory³⁷ and Jin and Levitt's observations about collaborative and multidisciplinary work in large, complex project performance. POW-ER explicitly models actors, activities, communication tools and organizations. POW-ER takes into account the actor's experience level and knowledge, and based on the extended information-processing view of organizations, POW-ER simulates the actions of, and interactions among, actors as processes of attention allocation, capacity allocation, and communication. POW-ER evaluates organization performance by measuring emergent project duration, direct cost, and coordination quality.³⁸

D. MIO/EMIO SPIRAL-1 TECHNOLOGY

Under the Maritime Domain Awareness Prototype program, PEO C4I has chartered Digital Force Technologies (DFT) to develop a Tactical EMIO System (TES) in order to enhance Spiral-1 MIO/EMIO capabilities. The TES consists of three components, which are the Tactical EMIO Device (TED), Tactical EMIO Maritime PC (TEMP), and Maritime Broadband Global Area Network (BGAN) EMIO Terminal (MBET). A general description and capability overview for each system component is as follows:

- TED – A handheld touch screen personal computer that contains a camera and user interface specifically designed to assist boarding team members with the collection of data.
- TEMP – A commercial-off-the-shelf (COTS) laptop that contains a user interface specifically designed to support the boarding officer with the aggregate collection of boarding data and review of collected information.
- MBET – Satellite terminal designed to connect the TEMP to the internet in order to transfer information.

³⁷ Yan Jin and Raymond E. Levitt, "The Virtual Design Team: A Computational Model of Project Organizations," Paper submitted to *Computational and Mathematical Organization Theory*, Stanford University, 15 March 1996.

³⁸ *Ibid.*, 3.

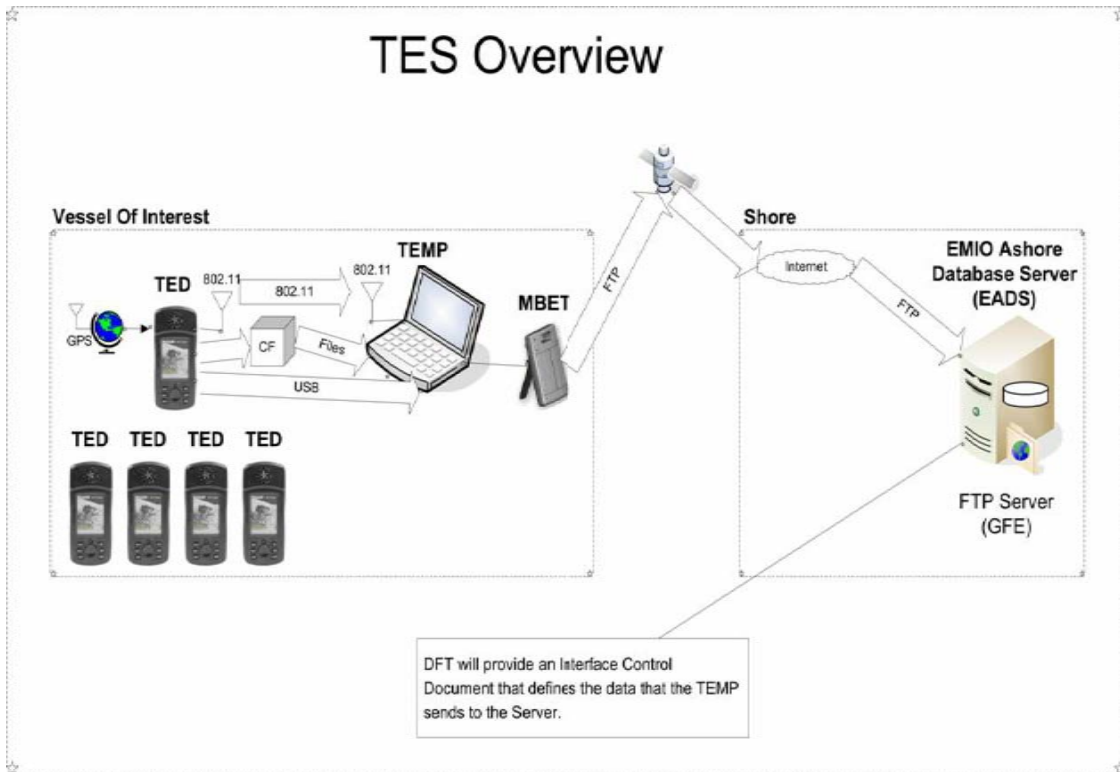

Figure 8. TES Overview

Figure 8 provides a TES overview that illustrates how each component is designed to interface with the other.³⁹ Boarding team members collect data from various areas on a vessel of interest by utilizing the TED and transmits gathered information into the TEMP via USB, 802.11, or flash card. The TEMP will be managed by the Boarding Officer and act as the central collection point for information gathered from TEDs. Once information has been verified and deemed appropriate for transmission, the Boarding Officer transmits boarding information via the MBET into automated intelligence systems located at various shore facilities for data validation and analysis. This process will be evaluated in POW-ER and reflected in the Business Process Reengineering (BPR) Phase III section in Chapter III.

³⁹ Digital Force Technology, Minutes of Meeting of Integration Design Review, Meeting of 15 April 2008.

III. REENGINEERING EXTENDED MARITIME INTERDICTION OPERATIONS

A. OVERVIEW

The Navy is currently reengineering Extended Maritime Interdiction Operations (EMIO) under the guide of a broader MDA Prototype program being developed in subsequent *Spirals*. At present, the MDA Prototype program is in its first Spiral which is not expected to be completed before this thesis is submitted. However, Leavitt Diamond variables, shown in Figure 9, such as management processes, information technologies, and business processes have been established and/or identified within Spiral-1 and can be examined utilizing BPR phases I through III. As such, it is the intent of this chapter to analyze the Navy's to date MIO/EMIO BPR efforts within the framework of Leavitt's Diamond in order to answer thesis question 1. **How will Spiral-1 technologies impact the command and control process for Maritime Interdiction Operations?**

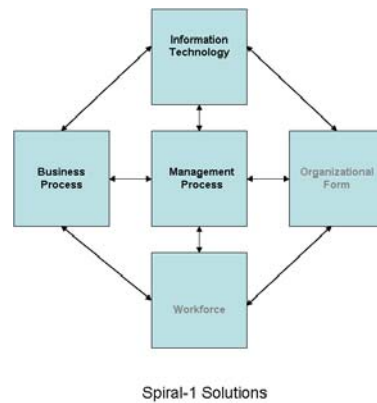

Figure 9. 'Spiral-1' Solutions in Leavitt's Diamond

The format for Chapter III MIO/EMIO Spiral-1 examination will consist of the application of Business Process Reengineering (BPR) within the overall MDA program followed by evaluation of EMIO specific processes determined from various guidance, interviews, and the author's experience.

B. BPR: PHASES I THROUGH III

1. Phase 1: Preparing to Implement

BPR projects involve cross-functional cooperation and changes to the status quo and planning for organizational changes are difficult to conduct without strategic direction from the top. Furthermore, the impact of the environmental changes that serve as the impetus for the reengineering effort must also be considered in establishing guidelines for the BPR project.⁴⁰ As such, the successful implementation of BPR entails five phases, the first phase being 'Preparing for BPR' consists of three activities: 1) building a cross functional team, 2) identify customer driven objectives, and 3) develop a strategic purpose, and the other phases will be discussed in chapter 4. The Secretary of the Navy (SECNAV) has initiated the first phase of the BPR process and all three activities have been achieved.

In a 17 May 2007 memorandum, the SECNAV established a cross functional team to field a prototype MDA capability by August 2008 satisfying activity one. The Deputy Chief of Naval Operations (Communication Networks) (N6) and Acting Deputy Under Secretary of the Navy (DUSN) were designated as co-chairs of a chartered MDA Cross Functional Team (CFT) to oversee this effort. The second and third activities in the first phase were achieved and provided in the following two documents: The Fleet Concept of Operations for Maritime Domain Awareness (MDA) (13 March 2007) and the Navy MDA Concept (29 May 2007), which describes the Fleet's role in MDA by defining how Fleet Commanders will develop and maintain MDA to accomplish Navy missions across the full Range of Military Operations (ROMO)⁴¹. The second activity, identify driven objective, is to provide a capability to improve the Situational Awareness (SA) within Maritime Domain Awareness (MDA) by deploying a full range of assets and capabilities, and the third activity, develop strategic purpose, is to provide boundaries and

⁴⁰ Subramanian Muthu, Larry Whitman, and S. Hossein Cheraghi, "Business Process Reengineering: A Consolidated Methodology," *Proceedings of the 4th Annual International Conference on Industrial Engineering Theory, Applications and Practice* (November 1999), 1-5.

⁴¹ "Scoping Document for Navy Maritime Domain Awareness (MDA) Spiral 1 Prototype," Revised January 2008 – Version 4.3.

expectations to the CFT to meet the objective. An overview of the Navy MDA Developmental Flow outlining the governing documents containing the management processes necessary for implementing Maritime Domain Awareness is shown in Figure 10.⁴² By burrowing down within the enterprise wide MDA program and focusing on the MIO/EMIO requirements as applied within the MDA Prototype effort, phase 1 BPR activities are revealed on a smaller scale.

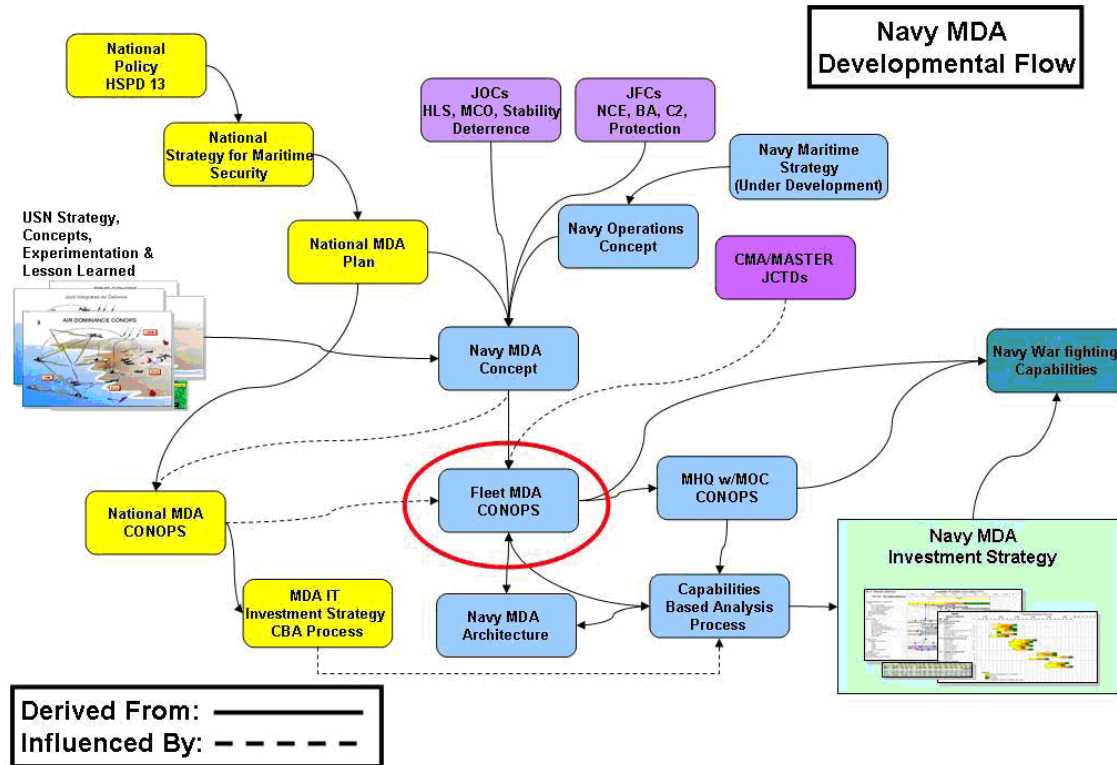

Figure 10. Navy MDA Developmental Flow

Activity 1, building a cross functional team, has been established by PEO C4I through the assignment of a team of individuals with various areas of expertise surrounding Program Management and Extended Maritime Interdiction Operations. The second activity, identify customer driven activities, has been accomplished through a great deal of input from NAVCENT, one of the key nodes and areas of responsibility listed in the SECNAV MDA memo. Activity three, develop a strategic purpose has been

⁴² The Concept of Operations for Fleet Maritime Domain Awareness (Fleet MDA CONOPS), March 2007.

outlined in a White Paper on MIO/EMIO and is being used by PEO C4I to focus EMIO Spiral-1 technology efforts. However, it is important to note, that unlike the greater MDA program that is driven by the SECNAV's vision, EMIO Spiral-1 efforts are bounded by current EMIO procedures and could be a problem if those procedures are not altered due to their implementation. As implied within Leavitt's Diamond, if the vision of achieving MDA is accomplished through a series of management processes designed to span throughout the organization, one could infer that EMIO as a component of MDA also needs to be driven by a new vision consistent with MDA. Further BPR analysis will reveal whether or not current EMIO management processes are an issue.

2. Phase 2: Map & Analyze 'As-Is' Process

The second phase of the BPR involves mapping and analyzing the 'As-Is' processes of the current system. This phase has four activities: 1) create activity models, 2) create process models, 3) simulate and perform activity based costing, and 4) identify disconnects and value adding processes. The Naval Postgraduate School is supporting the CFT during this phase and has developed a diagram that represents the 'As-Is' workflow, which has been reviewed and revised by more than 20 organizations that are involved in the MDA program⁴³. The 'As-Is' MDA workflow shown in Figure 11⁴⁴ was developed using the DoD Architecture Framework and subsequent operational view (OV) diagrams illustrating MDA activity and process models are contained in Appendix A.

⁴³ Jared Freeman, Shelley Gallup, Douglas MacKinnon and Susan Hutchins, "Maritime Domain Awareness (MDA) Workflow Model," Status Report, Naval Postgraduate School, 1 March 2008, 1.

⁴⁴ *Ibid.*, 24.

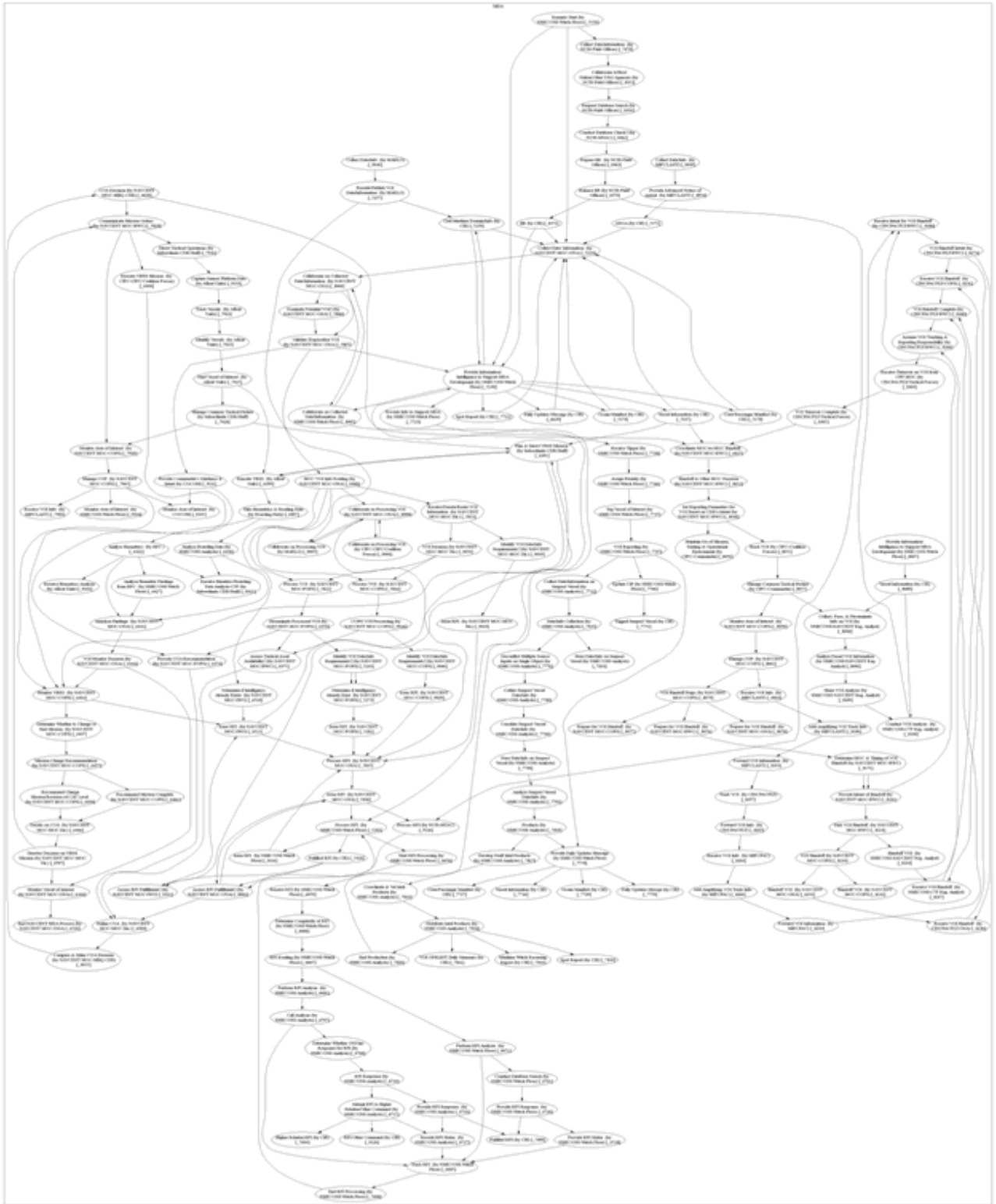

Figure 11. DoD Architecture Framework MDA Workflow Diagram

The EMIO workflow process, which is a small but significant part of the overall MDA process was derived from MDA workflow and operational diagrams, as well as NPS interviews with NAVCENT and ONI, EMIO After Action Reports (AAR), the Maritime Interception Operations Manual (NTTP 3-07.11), and LT Carroll’s experience gained from 91 executed boarding within NAVCENT’s AOR. Based on the complexity and busyness of the MDA workflow diagram, we developed an ‘As-Is’ operational EMIO model in POW-ER in order to model the four activities of BPR phase II.

a. Create Activity Models

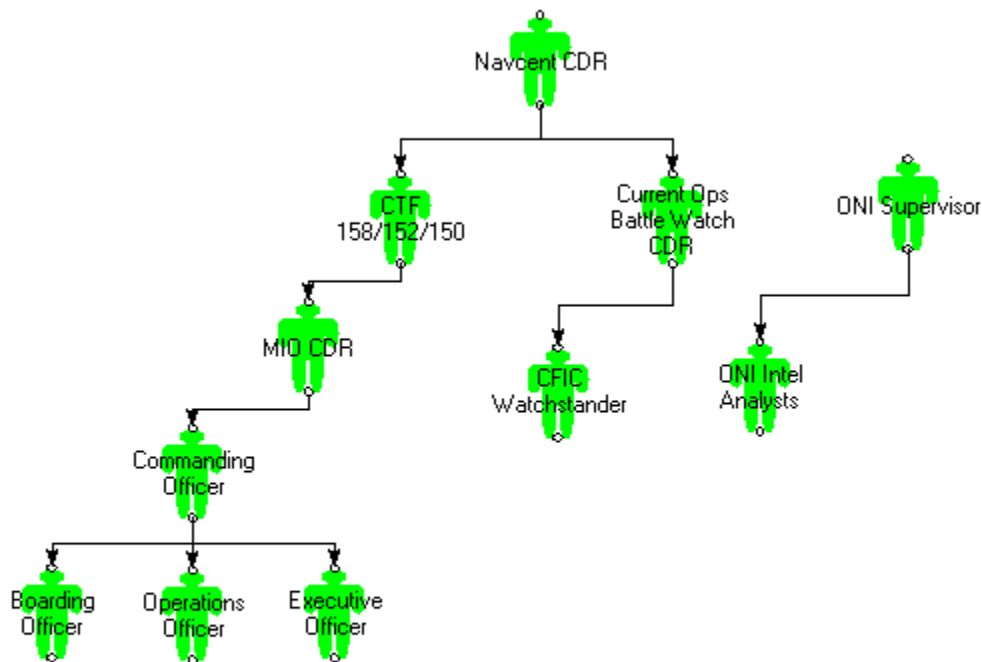

Figure 12. SAMPLE NAVCENT EMIO C2 Structure

The first activity in BPR Phase II calls for the need to create activity models that represent the ‘As Is’ organization or organizations responsible for completing a desired objective. Within NAVCENT’s AOR, the NAVCENT Commander is the overall authority responsible for the conduct of Maritime Interdiction Operations, as

shown in Figure 12. There are two organizations listed directly underneath the NAVCENT Commander. They are Commander Task Forces (CTF) and the Current Operations Department (COPS).

Current Operations, in particularly the Battle Watch Cell (BWC) within the department, is responsible for supporting EMIO activities being conducted within NAVCENT's area of control. The Coalition Forces Intelligence Center (CFIC) which operates in conjunction with the BWC is responsible for monitoring boarding operations. Combined, the CFIC and BWC support COPS by providing situational awareness and intelligence information regarding EMIO within the AOR.

CTF's are assigned regionally within NAVCENT's AOR and control the assets responsible for executing EMIO. Explanation of the EMIO C2 structure underneath the CTFs has been explained in Chapter 1. However, under the Commanding Officer, Figure 12 identifies additional participants in order to add fluidity to our POW-ER model.

Lastly, Figure 12 also recognizes the Office of Naval Intelligence as a supporting activity involved in the EMIO process. Within ONI, an Intelligence Supervisor and Analyst represent a team of individuals supporting NAVCENT EMIO activities.

b. Create Process Models

The second activity of BPR Phase II calls for the creation of process models that reflect the 'As Is' progression of tasks being performed. In order to satisfy this activity, we have derived a series of tasks from the two stages of EMIO listed in Figure 1 and modeled those tasks within the context of a generic scenario in POW-ER. The tasks utilized within the model are outlined in Table 1 and were obtained from the work conducted by the NPS MDA Workflow workshop, training manuals, AARs, interviews, and operational experience.

Table 1 illustrates the two stages of VBSS and lists the process milestones achieved during execution of boarding operations within the context of our scenario.

Under each milestone (highlighted in blue) there are three categories: task (yellow), activity (green), and process (black). Under the Task column, EMIO functions that require actions by an individual or organization are listed. The Activity column lists the individual(s) or organization(s) required to perform the function. The Process column lists the manner in which initiation or completion of the required task is moved to its next phase. Lastly, tasks are completed in a linear or concurrent fashion and can be determined in Table 1 by reading from top to bottom and left to right.

Current 'As-Is' Workflow Matrix		
Task	Activity Participants	Process
Start - VBSS Stage 2		
Collect Required Boarding Information	BO/OSC/MIC/CFIC	VHF (Secure), VHF (BTB), SHF (chat)
VOI clear or no clear	MIC	SHF (chat)
Boarding Information Gathering Complete		
BO Draft AAR	BO/OSC	Manual Input
Ops/XO/CO Review/Approve AAR	BO/OSC	Manual Input
Submit AAR	BO/OSC	SHF (msg traffic)
OSC Completes AAR Requirements		
Navcent/CTF/MIC Receive AAR	MIC/CFIC/ONI	Msg Traffic
Navcent/CTF/MIC File AAR	MIC/CFIC/ONI	Msg Traffic
AAR Reviewed and Filed by MIC for Records		
AAR Data Processed - VBSS Stage 1		
ONI Receive AAR Data (+7 hr time difference)	ONI	Msg Traffic
ONI Input AAR Data into Info Sys	ONI	Manual Input
ONI Analyze AAR Data	ONI	Automation
ONI Generate Tipper from Actionable Intel	ONI	Manual Input
ONI Submit Tipper to Navcent	ONI/BWC	Msg Traffic
Navcent Receive Tipper/Issue VBSS Order (-7 hr Time Difference)	CTF/BWC/CFIC	Standard Operating Procedures
BWC Receive Tipper/Draft FRAGORD	BWC/CFIC	Msg Traffic, Manual Input
BWC Submit FRAGORD	BWC/CFIC/CTF	Msg Traffic
CTF Receive FRAGORD & Forward tasking to MIC	CTF/MIC	Msg Traffic
MIC Receive FRAGORD/Draft OPTASK MIO SUP	MIC	Msg Traffic
Execute MIO - VBSS Stage 2		
MIC Submits OPTASK MIO SUP	MIC/OSC	Msg Traffic
OSC Receive OPTASK MIO SUP & Intercept VOI	MIC/OSC	Msg Traffic, VHF (BTB), SHF (chat)
BO Conduct VBSS/Detain COI	BO/OSC/MIC/CFIC	VHF (Secure), VHF (BTB), SHF (chat)
Finish - Mission Complete		

Table 1. EMIO 'As-Is' Workflow Matrix

c. Simulate and Perform Activity Based Costing

The third activity needed to satisfy BPR Phase II, is to simulate and perform activity based costing on the 'As Is' model. In order to perform this function, we simulated the tasks, activities, and processes outlined in Table 1 utilizing POW-ER in order to identify critical paths and bottlenecks within the EMIO workflow process. The

generic scenario utilized for modeling takes place within the NAVCENT AOR and follows the transformation process of data collected during routine boarding operations leading to the development of actionable intelligence resulting in the detainment of a particular Contact of Interest (COI). Figure 13 provides a screen-capture of this scenario as performed within the POW-ER model and reflects the workflow of tasks as they are performed by activities. Blue arrows drawn from the individual to tasks indicate which individual or organization that will be performing that work. The black arrows between the blue milestones and yellow tasks indicate the direction of workflow. The green arrows connecting various tasks represent direct communication links and the black arrows connecting activities represent the EMIO C2 hierarchy within NAVCENT's AOR.

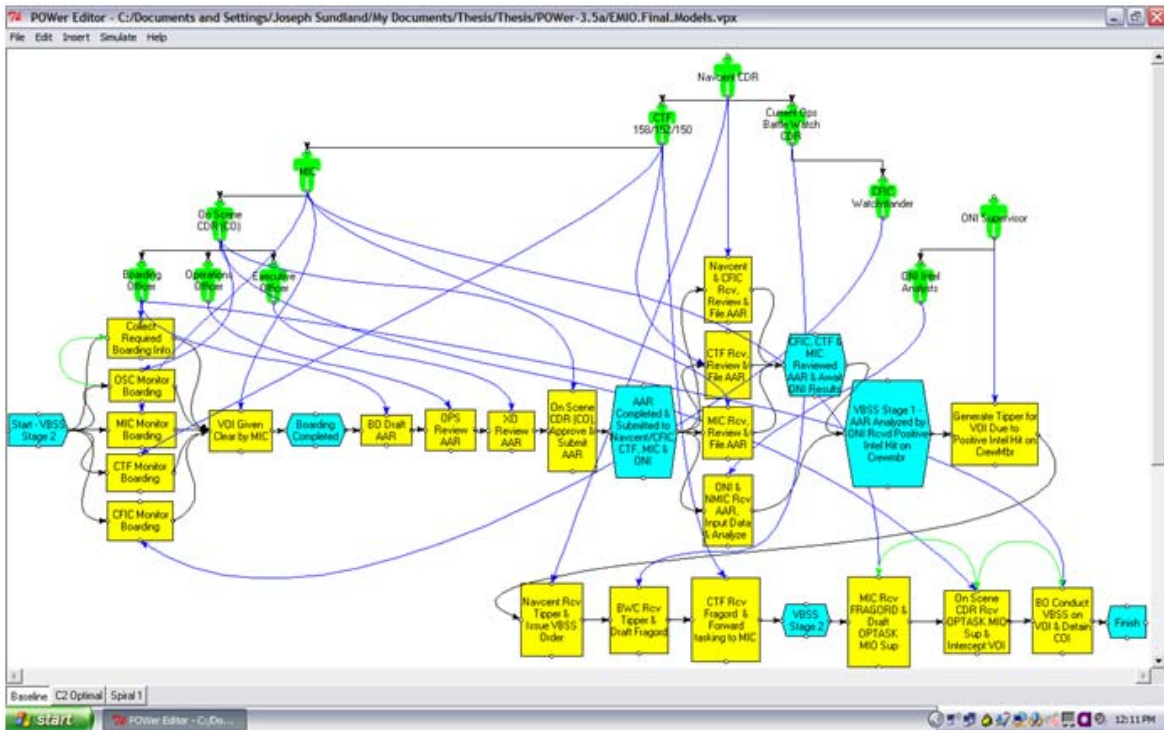

Figure 13. EMIO 'As-Is' POW-ER Model

d. Identify Disconnects and Value Adding Processes

The fourth activity of BPR phase II calls for the need to identify disconnects and value adding processes within the 'As-Is' system. After running the

model, Table 2 reveals a very long tedious 34 hour EMIO workflow process to collect, send, analyze and then disseminate actionable intelligence back to decision-makers. As can be seen in Table 2, the disconnect identified within the model is the time for ONI to receive, input and analyze the boarding data and turn it into actionable intelligence. The total time between collecting boarding data and generating information from completing analysis of that data takes 1130 minutes or approximately 18 hours. In today’s environment where data transfer rates are extremely fast, decreasing the time between collecting and analyzing data can be greatly improved. By implementing Spiral-1 technologies, PEO C4I has chosen this course of action to improve the EMIO workflow process.

Current 'As-Is' Scenario Workflow Matrix							
Task	Activity Participants	Process	Duration		Time	Date	
			Minutes	Days			
Start - VBSS Stage 2					10:00 AM	1-May	
Collect Required Boarding Information	BO/OSC/MIC/CFIC	VHF (Secure), VHF (BTB), SHF (chat)	60	0.042	11:00 AM	1-May	
VOI clear or no clear	MIC	SHF (chat)	15	0.010	11:15 AM	1-May	
Boarding Information Gathering Complete							
BO Draft AAR	BO/OSC	Manual Input	30	0.021	11:45 AM	1-May	
Ops/XO/CO Review/Approve AAR	BO/OSC	Manual Input	45	0.031	12:30 PM	1-May	
Submit AAR	BO/OSC	SHF (msg traffic)	20	0.014	12:50 PM	1-May	
OSC Completes AAR Requirements							
Navcent/CTF/MIC Receive AAR	MIC/CFIC/ONI	Msg Traffic	0	0.000	12:50 PM	1-May	
Navcent/CTF/MIC File AAR	MIC/CFIC/ONI	Msg Traffic	0	0.000	12:50 PM	1-May	
AAR Reviewed and Filed by MIC for Records							
AAR Data Processed - VBSS Stage 1							
ONI Receive AAR Data (+7 hr time difference)	ONI	Msg Traffic	420	0.292	9:50 PM	1-May	
ONI Input AAR Data into Info Sys	ONI	Manual Input	600	0.417	7:50 AM	2-May	
ONI Analyze AAR Data	ONI	Automation	60	0.042	8:50 AM	2-May	
ONI Generate Tipper from Actionable Intel	ONI	Manual Input	60	0.042	9:50 AM	2-May	
ONI Submit Tipper to Navcent	ONI/BWC	Msg Traffic	20	0.014	10:10 AM	2-May	
Navcent Receive Tipper/Issue VBSS Order (-7 hr Time Difference)	CTF/BWC/CFIC	Standard Operating Procedures	60	0.042	4:10 AM	2-May	
BWC Receive Tipper/Draft FRAGORD	BWC/CFIC	Msg Traffic, Manual Input	120	0.083	6:10 AM	2-May	
BWC Submit FRAGORD	BWC/CFIC/CTF	Msg Traffic	20	0.014	6:30 AM	2-May	
CTF Receive FRAGORD & Forward tasking to MIC	CTF/MIC	Msg Traffic	60	0.042	7:30 AM	2-May	
MIC Receive FRAGORD/Draft OPTASK MIO SUP	MIC	Msg Traffic	60	0.042	8:30 AM	2-May	
Execute MIO - VBSS Stage 2							
MIC Submits OPTASK MIO SUP	MIC/OSC	Msg Traffic	20	0.014	8:50 AM	2-May	
OSC Receive OPTASK MIO SUP & Intercept VOI	MIC/OSC	Msg Traffic, VHF (BTB), SHF (chat)	360	0.250	2:50 PM	2-May	
BO Conduct VBSS/Detain COI	BO/OSC/MIC/CFIC	VHF (Secure), VHF (BTB), SHF (chat)	60	0.042	3:50 PM	2-May	
Finish - Mission Complete			2090	1.451	34.82 hours		

Table 2. EMIO ‘As-Is’ Workflow Results

3. Design ‘To-Be’ Processes

The third phase of BPR calls for the need to design the ‘To-Be’ processes of the proposed system. Similar to BPR phase II, this phase has four activities: 1) benchmark processes, 2) design ‘To-Be’ processes, 3) validate ‘To-Be’ processes, and 4) perform a trade-off analysis. The *Scoping Document for Maritime Domain Awareness Spiral-1*

Prototype published 30 November 2007 and revised 01 January 2008 provides guidance regarding the boundaries and expectations of the first Spiral of the SECNAV’s MDA prototype.⁴⁵ Within this document, the CFT has outlined a series of MDA capability and technology implementation requirements designed to meet SECNAV goals and deadlines. Figure 14 provides a matrix outlining Spiral-1 capabilities sought after by the SECNAV, and Figure 15 provides a modified version of the EMIO appropriate section of the MDA technology implementation matrix provided in the *Scoping Document*. Activities 2 through 4 of BPR phase III, as they apply to EMIO and the MDA prototype, are in progress and should be completed by August 2008. However, knowing the capabilities sought and the technologies selected to improve EMIO, POW-ER modeling allows us to continue BPR analysis in order to assess the impact of Spiral-1 technologies on EMIO Command and Control.

MONITOR	<ul style="list-style-type: none"> - Maritime Headquarters w/ Maritime Operations Center Integrated with MDA capability
COLLECT	<ul style="list-style-type: none"> - Maritime Headquarters w/ Maritime Operations Center Integrated with MDA capability - Improved Access to Non-Navy Maritime Information - Improved 2-way Wireless Transmission of EMIO data - Maritime Data Archives for Navy-wide Use
FUSE	<ul style="list-style-type: none"> - Maritime Headquarters w/ Maritime Operations Center Integrated with MDA capability - Improved Access to Non-Navy Maritime Information - Collaborative Toolset for Data Sharing and Analysis
ANALYZE	<ul style="list-style-type: none"> - Maritime Headquarters w/ Maritime Operations Center Integrated with MDA capability - Expanded SME for Regional Info Exploitation and ID of Adversary Patterns and Tactics - Automated Maritime Pattern Recognition and Anomaly Detection - Collaborative Toolset for Data Sharing and Analysis
DISSEMINATE	<ul style="list-style-type: none"> - Maritime Headquarters w/ Maritime Operations Center Integrated with MDA capability - User-Defined Operational Picture w/ Multiple Data Streams (Classified & Unclassified) - Improved Access to Non-Navy Maritime Information - Maritime Data Archives for Navy-wide Use - Collaborative Toolset for Data Sharing and Analysis - Automated Afloat Maritime Data Collection (for EMIO) - Data Provided and used at Multiple Levels of Security

Figure 14. Operational Capability Alignments with the Fleet CONOPS

⁴⁵ “Scoping Document for Navy Maritime Domain Awareness (MDA) Spiral 1 Prototype,” Revised January 2008 – Version 4.3, 3.

Spiral-1 Technology Implementation

Capability	Node	Technology	Improvement
E-MIO (People)	<ol style="list-style-type: none"> 1. Boarding Party 2. Intelligence Center 	<ol style="list-style-type: none"> 1a. Tactical EMIO Device (to wireless/SATCOM) 1b. Portable SATCOM 2. Intelligence Support System upgrades 	<ul style="list-style-type: none"> - Wireless comms from boarding party, reducing latency for data exfiltration - Improved boarding team safety - Capture & disseminate VBSS data - Automated ingest of boarding data into authoritative databases - Disseminate data for E-MIO mission planning

Figure 15. Spiral-1 Tech Implementation Node Mapping

a. Benchmark the Process

The first activity of BPR phase III describes the need to benchmark the processes of the ‘To-Be’ system to be put in place. This activity has been fulfilled with the establishment of requirements outlined in the *Scoping Document for MDA Spiral-1 Prototype* and subsequent documents produced by various CFT workgroups. Figure 14 provides an outlook on Spiral-1 EMIO capabilities sought and Figure 15 lists nodes and technologies with their desired affect.

b. Designing the ‘To-Be’ Process

The second activity of BPR phase III calls for the design of the ‘To-Be’ process. By conceptualizing the capabilities of Spiral-1 technologies and applying the same construct described in section 2b of this Chapter, we were able to create the matrix shown in Table 3 by outlining the transformation of the collected boarding data as it progressed through the generic scenario used earlier. As can be seen in Table 3, the tasks between VBSS Stages 2 and 1 of the VBSS mission are significantly reduced.

This can be explained by the use of the Tactical EMIO System (TES) and verified in the next phase of analysis.

Spiral-1 'To-Be' Matrix		
Start - VBSS Stage 2		
Collect Required Boarding Information	BO/OSC/MIC/CFIC	VHF (Secure), VHF (BTB), SHF (chat), TES
Boarding Data Forwarded via BGAN	CTF/MIC/CFIC/ONI	BGAN Satellite
VOI clear or no clear	MIC	SHF (chat)
Boarding Information Analysis - VBSS Stage 1		
ONI Analyze Boarding Data (+7 hr Time Difference)	ONI	Automation
ONI Generate Tipper from Actionable Intel	ONI	Manual Input
ONI Submit Tipper to Navcent	ONI/BWC	Msg Traffic
Navcent Receive Tipper/Issue VBSS Order (-7 hr Time Difference)	CTF/BWC/CFIC	Standard Operating Procedures
BWC Receive Tipper/Draft FRAGORD	BWC/CFIC	Msg Traffic, Manual Input
BWC Submit FRAGORD	BWC/CFIC/CTF	Msg Traffic
CTF Receive FRAGORD & Forward tasking to MIC	CTF/MIC	Msg Traffic
Execute MIO - VBSS Stage 2		
MIC Receive FRAGORD/Draft OPTASK MIO SUP	MIC	Msg Traffic
MIC Submits OPTASK MIO SUP	MIC/OSC	Msg Traffic
OSC Receive OPTASK MIO SUP & Intercept VOI	MIC/OSC	Msg Traffic, VHF (BTB), SHF (chat)
BO Conduct VBSS/Detain COI	BO/OSC/MIC/CFIC	VHF (Secure), VHF (BTB), SHF (chat), TES
Finish - Mission Complete		

Table 3. EMIO Spiral-1 'To-Be' Matrix

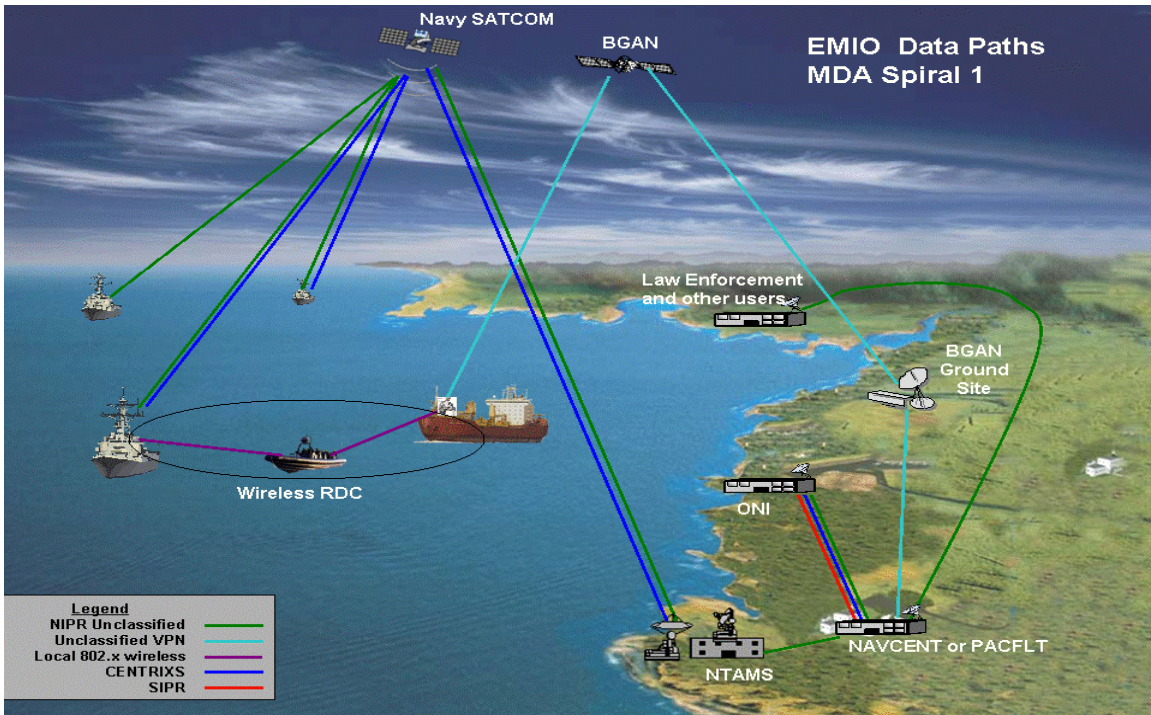

Figure 16. EMIO 'Spiral-1' Data Paths

c. Validating the ‘To-Be’ Process

The third activity of BPR phase III calls for the validation of the ‘To-Be’ process. In order to accomplish this task, Figure 16 taken from the MIO/EMIO White Paper provides an illustration of the EMIO ‘To-Be’ workflow within the context of our scenario. Data collected on a vessel of interest through the use of the Tactical EMIO System (TES) is transmitted to intelligence support via BGAN satellite and shore terminal. Once that data is analyzed, turned into information, and transformed into actionable intelligence, that knowledge is communicated back to MIO Commanders through conventional means. The legend in Figure 16 provides a description of the communications medium used to transmit data. However, it is important to note that the use of wireless communication between the OSC and Boarding Team illustrated in Figure 16 is sparsely utilized and not apart of the MDA Prototype Program. As such, standard VHF communications between the OSC and Boarding Officer as illustrated in Figure 1 will be demonstrated in the ‘To-Be’ model. Furthermore, Figure 16 is just for illustration purposes and designed to show the EMIO data paths for Spiral-1. It should not be implied as illustrating increased processing speed or that the same MIO Commander, On-Scene Commander, and Boarding Team are interdicting the vessel of interest. Considering the use of traditional communication mediums from shore side intelligence support to MIO Commanders, we are assuming that the ‘To-Be’ workflow process between Stages 1 and 2 remain the same as illustrated in the ‘As-Is’ workflow matrix. Therefore, validation of our ‘To-Be’ model, shown in Figure 17, is complete; and the results from the final activity of BPR phase III, ‘performing a trade-off analysis’, are presented in the next section.

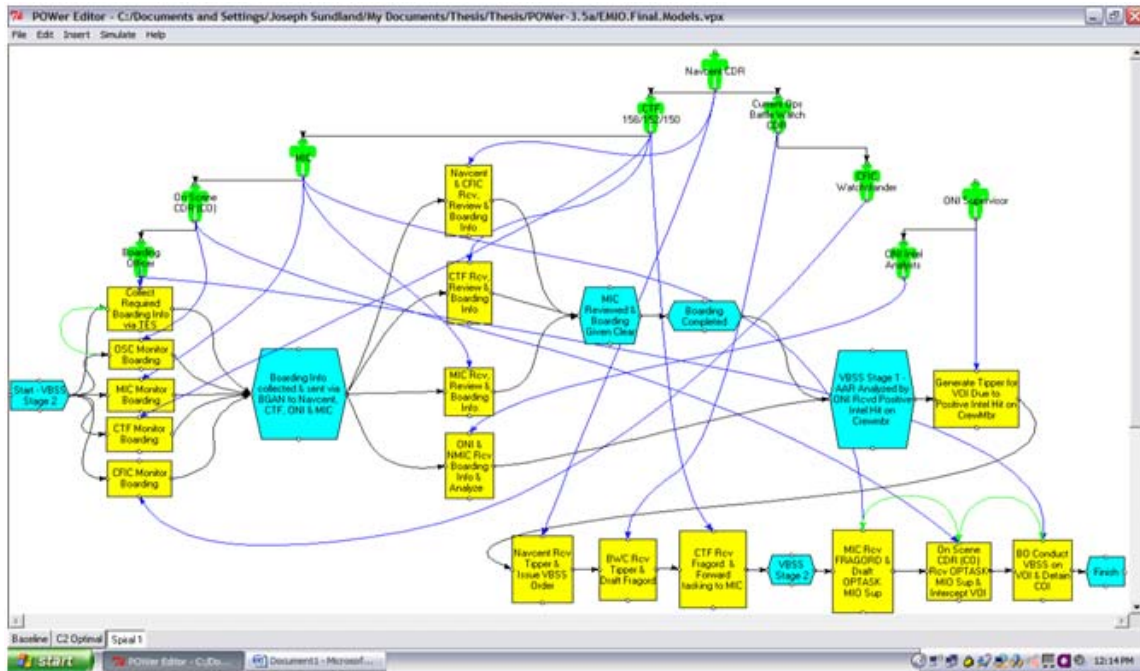

Figure 17. EMIO ‘Spiral-1’ POW-ER Model

d. Performing a Trade-Off Analysis

The final activity of BPR phase III, requires a trade-off analysis to be performed. As shown in Figure 17, the EMIO workflow process has been changed with the addition of Spiral-1 technologies in order to expedite the transfer of data from the Boarding Officer to the intelligence analyst to be analyzed and turned into actionable intelligence. However, once the boarding data is analyzed, the actionable intelligence gets forwarded back to decision-makers via the same time consuming path as in the ‘As-Is’ EMIO workflow model. Once the Spiral-1 technologies are implemented into the EMIO workflow process, there is a noteworthy reduction in the amount of time it takes to transfer the data to the intelligence analyst and it decreases the overall time to complete this process, which is approximately 21 hours as shown in Table 4. The trade-off between the Spiral-1 ‘To-Be’ workflow process and ‘As-Is’ workflow process is a noteworthy reduction of approximately 14 hours of time. Since there has been a significant change in the workflow process, we can now infer how Spiral-1 technologies will impact the EMIO Command and Control process. The implementation of Spiral-1 technologies has

improved the speed of transferring data from the Boarding Officer to the Intelligence Analyst reducing the overall EMIO workflow cycle time.

Spiral-1 'To-Be' Workflow Matrix							
Task	Activity Participants	Process	Duration		Time	Date	
Start - VBSS Stage 2							
Collect Required Boarding Information	BO/OSC/MIC/CFIC	VHF (Secure), VHF (BTB), SHF (chat), TES	30	0.021	10:00 AM	1-May	
Boarding Data Forwarded via BGAN	CTF/MIC/CFIC/ONI	BGAN Satellite	5	0.003	10:35 AM	1-May	
VOI clear or no clear	MIC	SHF (chat)	15	0.010	10:50 AM	1-May	
Boarding Information Analysis - VBSS Stage 1							
ONI Analyze Boarding Data (+7 hr Time Difference)	ONI	Automation	360	0.250	5:50 PM	1-May	
ONI Generate Tipper from Actionable Intel	ONI	Manual Input	60	0.042	6:50 PM	1-May	
ONI Submit Tipper to Navcent	ONI/BWC	Msg Traffic	20	0.014	7:10 PM	1-May	
Navcent Receive Tipper/Issue VBSS Order (-7 hr Time Difference)	CTF/BWC/CFIC	Standard Operating Procedures	60	0.042	1:10 PM	1-May	
BWC Receive Tipper/Draft FRAGORD	BWC/CFIC	Msg Traffic, Manual Input	120	0.083	3:10 PM	1-May	
BWC Submit FRAGORD	BWC/CFIC/CTF	Msg Traffic	20	0.014	3:30 PM	1-May	
CTF Receive FRAGORD & Forward tasking to MIC	CTF/MIC	Msg Traffic	60	0.042	4:30 PM	1-May	
Execute MIO - VBSS Stage 2							
MIC Receive FRAGORD/Draft OPTASK MIO SUP	MIC	Msg Traffic	60	0.042	5:30 PM	1-May	
MIC Submits OPTASK MIO SUP	MIC/OSC	Msg Traffic	20	0.014	5:50 PM	1-May	
OSC Receive OPTASK MIO SUP & Intercept VOI	MIC/OSC	Msg Traffic, VHF (BTB), SHF (chat)	360	0.250	11:50 PM	1-May	
BO Conduct VBSS/Detain COI	BO/OSC/MIC/CFIC	VHF (Secure), VHF (BTB), SHF (chat), TES	60	0.042	12:50 AM	2-May	
Finish - Mission Complete			1250	0.868	20.83 hours		

Table 4. EMIO Spiral-1 'To-Be' Workflow Results

IV. TRANSFORMING DATA INTO ACTIONABLE INTELLIGENCE

As suggested in the previous Chapter, Spiral-1 technologies significantly improve the Command and Control cycle time of Extended Maritime Interdiction Operations by automating the transformation of data into intelligence systems for analysis. However, as implied in Leavitt's Diamond and discussed in Chapter 2, any enterprise wide change solution implemented to address a particular task will inevitably affect other organizational variables. In this case, Spiral-1 technology solutions for streamlining the EMIO process have been chosen for implementation, but their impact on other variables within the EMIO mission is unknown. As such, it is the intent of this chapter to apply adjustments to remaining Leavitt Diamond variables in order to maintain functional harmony due to the change in the technology variable. In doing so, we intend to answer thesis question 2, what is the optimal Extended Maritime Interdiction Operations Command and Control structure after Spiral-1 technology implementation.

A. IMPLEMENT REENGINEERED PROCESSES

The fourth phase of BPR calls for the need to implement the reengineered processes of the proposed system. This phase has four activities: 1) evolve an implementation plan, 2) prototype and simulate the transition plan, 3) initiate training programs, and 4) implement a transition plan. As mentioned in Chapter 3, implementation of MDA prototype Spiral-1 technologies is planned for August 2008, and Spiral-2 completion is planned for August 2009. Theoretically, all the activities for the fourth phase of BPR should be completed by that time. Fortunately, modeling affords us the opportunity of looking ahead at the potential effects of implementing change solutions throughout the entire EMIO process. By recapping the Spiral-1 change variables in place and conceptualizing change solutions we were able to develop and simulate our hypothetical model in POW-ER as the optimal EMIO C2 structure.

As shown in Figure 17, addition of the Spiral-1 technologies to the EMIO workflow process has expedited the transfer of boarding data from the Boarding Officer

to the intelligence analyst to be analyzed and returned to decision-makers as actionable intelligence. Unfortunately, once the boarding data is analyzed, the actionable intelligence gets returned back to decision-makers via the same time-consuming path as indicated by the long red ‘critical path’ bars illustrated in the ‘As-Is’ and ‘To-Be’ EMIO workflow Gantt charts shown respectfully in Figures 18 and 19.

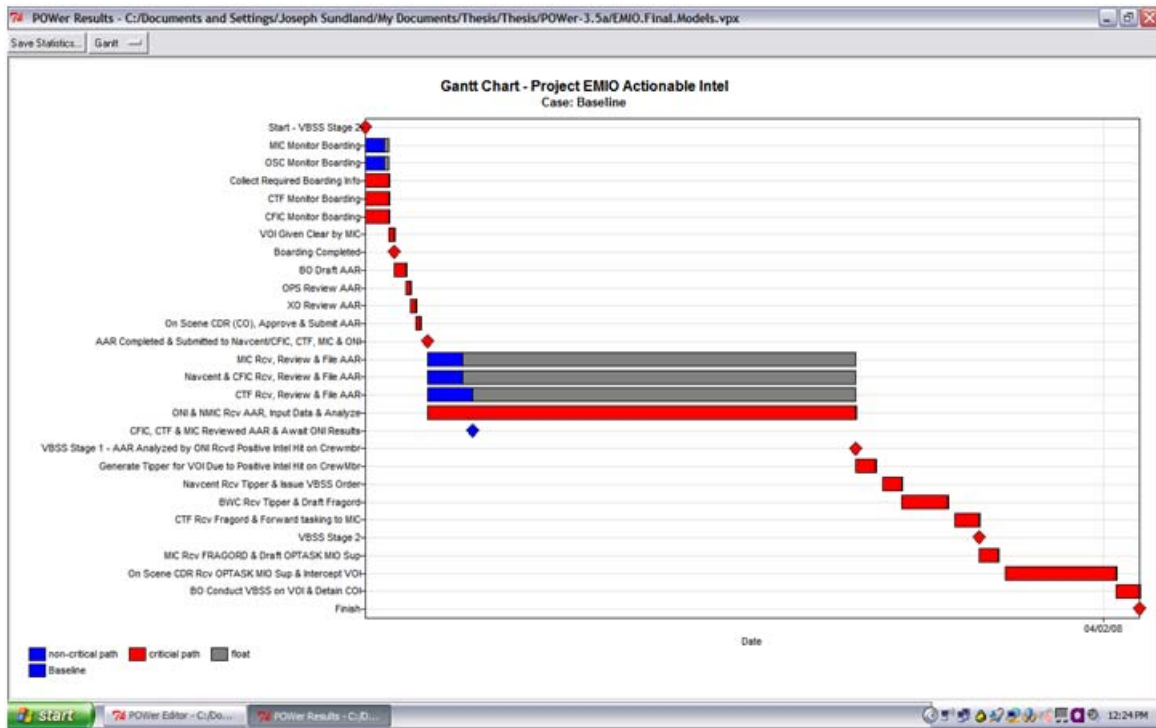

Figure 18. EMIO ‘As-Is’ Workflow Gantt Chart

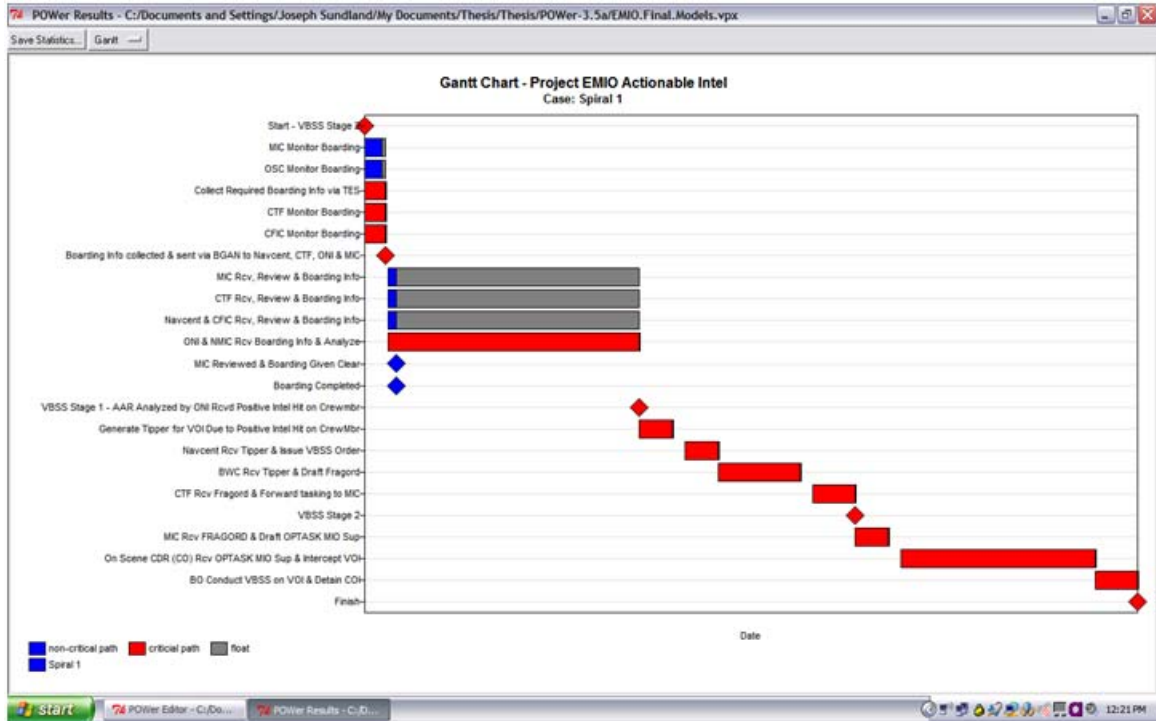

Figure 19. EMIO ‘Spiral-1’ Workflow Gantt Chart

The Gantt charts above coincide with their respective Scenario Matrices discussed in Chapter III and reflect the 14 hour time savings resulting from the implementation of Spiral-1 technologies. The Gantt chart does not reveal the time variable on its x-axis but this information is displayed in their respective scenario matrices in Tables 2 and 4. Spiral-1 technologies have shortened the critical paths between the collection of the boarding data to the fusion of that data into intelligence systems leaving room to reduce the critical paths throughout the rest of the EMIO process. By applying solutions to the remaining change variables in Leavitt’s Diamond we can provide an optimal C2 structure.

B. APPLYING LEAVITT’S DIAMOND

Information Technology solutions have been chosen to improve the Business Processes of Extended Maritime Interdiction Operations. In order to implement our

optimal EMIO workflow process, we will offer and apply solutions to the remaining three variables of Leavitt's Diamond in order to maintain functional harmony throughout our model.

1. People Solutions

According to Harold Leavitt, *people* solutions for organizational change typically involve changing the attitudes of the people involved in the process. Determining people solutions can be conducted through group discussions, face-to-face meetings, and open-ended interviews.⁴⁶ By analyzing the NAVCENT interviews conducted by NPS and Space and Naval Warfare (SPAWAR) and discussed in Chapter I, it can be inferred that NAVCENT operators are arguing to be more actively involved in the EMIO process. In order to accomplish this solution it is necessary to change the roles and responsibilities of the people involved as well as their attitudes.

Currently, NAVCENT does not possess the capability to provide identification and validation of boarding data to be actively involved in the EMIO process. Since ONI possesses the capability to identify and validate boarding data, one can infer that ONI's active participation in the process is needed. Therefore, attitudes of ONI personnel will have to change from a support role to an operational role in order to provide NAVCENT with the service capabilities they need. If this change were to occur, then adjustments to the existing organizational form must happen.

2. Organizational Form Solutions

When seeking to implement changes to an organization's form, solutions normally involve the following: 1) rewriting job descriptions with greater precision to get rid of overlapping responsibilities, 2) changing the functional form of an organization and converting it into a product form, 3) decentralizing the organization and give a lot more authority to product makers, and 4) people may need to be moved out of the process because there is too much fat in the organization.⁴⁷ In application to the EMIO process,

⁴⁶ Harold J. Leavitt, *Managerial Psychology* (Chicago: The University of Chicago Press, 1978), 284.

⁴⁷ *Ibid.*, 283-284.

organizational form solutions that focus on changing the functional form of the organizations involved in this process and converting the command and control structure into a form that produces mission results will be utilized in our ‘optimal’ POW-ER model, and the organizational diagram is illustrated in Figure 20.

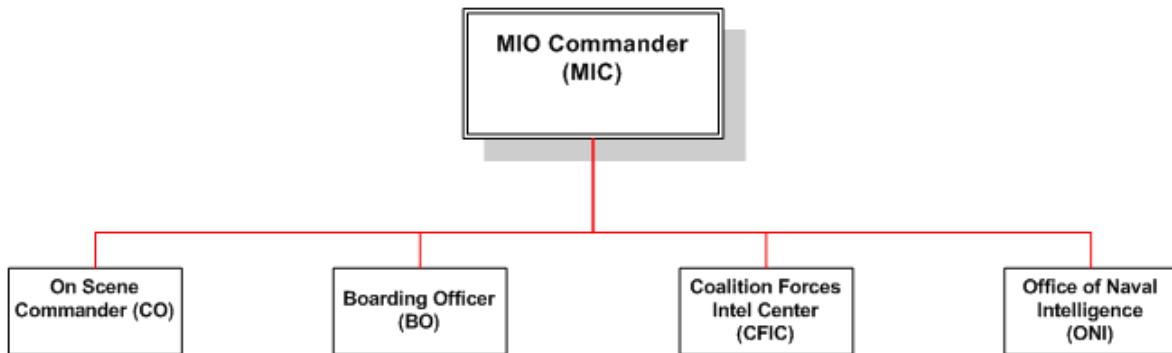

Figure 20. EMIO ‘Near-Optimal’ C2 Structure

3. Management Processes

Management process solutions for change involve a clear vision from top management, buy-in from middle management, and active user participation.⁴⁸ The MDA prototype program has a clear vision for change, but the Spiral-1 EMIO workflow process relies on existing operational procedures rather than updated procedures that reflect changes in the EMIO C2 processes and structure. In order to implement people and organizational form solutions throughout Extended Maritime Interdiction Operations, a clear vision consistent with the greater MDA mission must be articulated by top and middle level management and embraced by the users. Now that we have addressed the three remaining change variables in Leavitt’s Diamond we are now ready to simulate our reengineered and near-optimal EMIO model. Our use of the term near-optimal indicates our acknowledgement of other, perhaps yet unknown, variables that may also be affected to improve the model at present.

⁴⁸ Michael S. Scott Morton, *The Corporation of the 1990s* (New York and Oxford: Oxford University Press 1991), 262-265.

C. NEAR-OPTIMAL EMIO COMMAND AND CONTROL STRUCTURE

In keeping with the Business Process Reengineering philosophy, we have developed an optimal EMIO workflow process that takes in account the remaining change variables in the previous section. By running the same scenario used earlier, Table 5 illustrates the tasks, activities, and process resulting from the changes, and Figure 21 is a screenshot of the simulation in POW-ER.

Optimal C2 Matrix		
Task	Activity Participants	Process
Start - VBSS Stage 2		
Collect Required Boarding Information	BO/OSC/MIC/CFIC/ONI	VHF (Secure), VHF (BTB), SHF (chat), TES
Boarding Data Forwarded via BGAN	CTF/MIC/CFIC/ONI	BGAN Satellite
Boarding Data fwd via BGAN to CTF/MIC/CFIC for filing and ONI for Analysis - VBSS Stage 1		
CTF/MIC/CFIC Receive & Review data	CTF/MIC/CFIC	Automation
ONI Analyze Boarding Data	ONI	Automation
VBSS Stage 1		
ONI Generate Tipper from Actionable Intel	ONI	SHF (CHAT)
Tipper Information submitted via Chat to CTF/MIC/CFIC/OSC		
Actionable Intelligence provided Generate Plan	MIC/CFIC/OSC	SHF (CHAT)
MIC Forwards Generated Plan to OSC	MIC/OSC	SHF (CHAT)
VBSS Stage 2		
OSC Coordinates Action	MIC/OSC/BO	VHF (Secure), VHF (BTB), SHF (chat), TES
OSC Passes Plan to BO	OSC/BO	VHF (Secure)
BO Executes Action and Detains COI	BO	
Finish - Mission Complete		

Table 5. EMIO 'Near-Optimal' Matrix

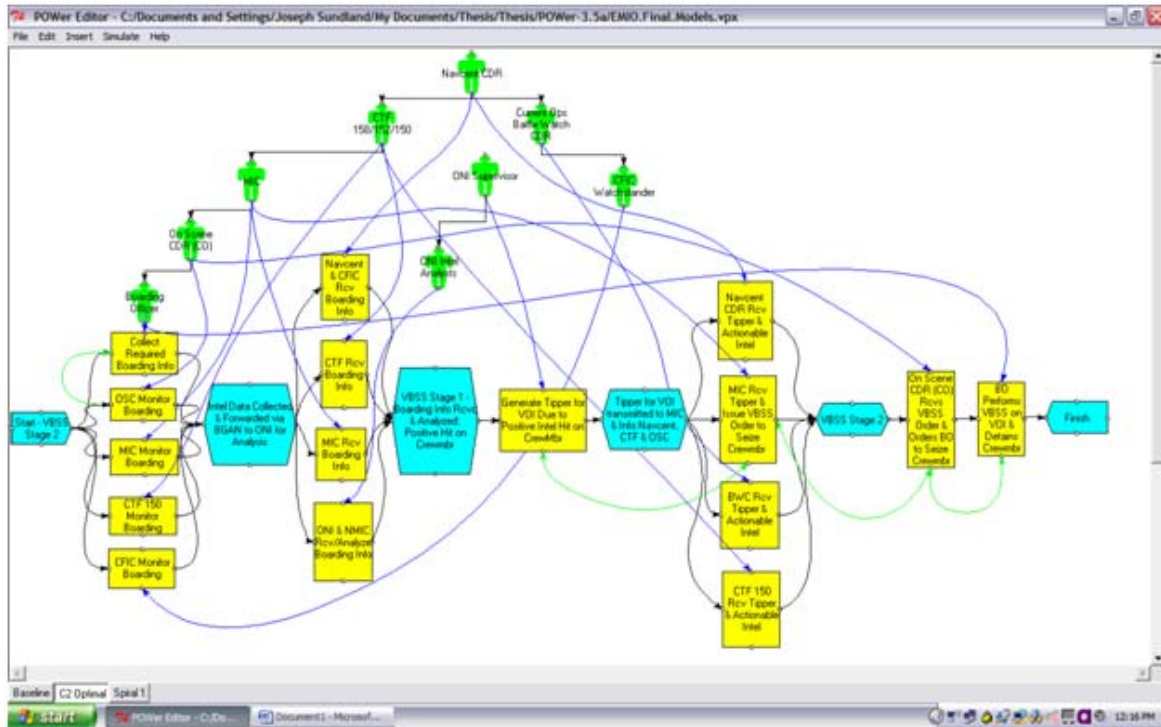

Figure 21. EMIO ‘Near-Optimal’ POW-ER Model

The optimal EMIO C2 structure, implemented from all the solutions suggested above, involve a more active relationship between the boarding officer collecting the data and the intelligence analyst processing the collected information. These individuals have been determined as the product creators within the EMIO workflow process and are reflected in our model shown in Figure 21. Transformation of the knowledge gained from the information processed by the intelligence analyst is then transmitted through existing collaborative technologies that will allow decision-makers to perform concurrent actions necessary based on the actionable intelligence gained. The results of our near-optimal ‘EMIO’ workflow model are presented in Table 6.

Optimal C2 Matrix							
Task	Activity Participants	Process	Duration		Time	Date	
Start - VBSS Stage 2							
Collect Required Boarding Information	BO/OSC/MIC/CFIC/ONI	VHF (Secure), VHF (BTB), SHF (chat), TES	30	0.021	10:00 AM	1-May	
Boarding Data Forwarded via BGAN	CTF/MIC/CFIC/ONI	BGAN Satellite	5	0.003	10:35 AM	1-May	
Boarding Data fwd via BGAN to CTF/MIC/CFIC for filing and ONI for Analysis - VBSS Stage 1							
CTF/MIC/CFIC Receive & Review data	CTF/MIC/CFIC	Automation	15	0.010	10:50 AM	1-May	
ONI Analyze Boarding Data	ONI	Automation	45	0.031	11:35 AM	1-May	
VBSS Stage 1							
ONI Generate Tipper from Actionable Intel	ONI	SHF (CHAT)	60	0.042	12:35 PM	1-May	
Tipper information submitted via Chat to CTF/MIC/CFIC/OSC							
Actionable Intelligence provided Generate Plan	MIC/CFIC/OSC	SHF (CHAT)	20	0.014	12:55 PM	1-May	
MIC Forwards Generated Plan to OSC	MIC/OSC	SHF (CHAT)	5	0.003	1:00 PM	1-May	
VBSS Stage 2							
OSC Coordinates Action	MIC/OSC/BO	VHF (Secure), VHF (BTB), SHF (chat), TES	5	0.003	1:05 PM	1-May	
OSC Passes Plan to BO	OSC/BO	VHF (Secure)	5	0.003	1:10 PM	1-May	
BO Executes Action and Detains COI	BO		10	0.006	1:20 PM	1-May	
Finish - Mission Complete			200	0.128	3.33 hours		

Table 6. EMIO ‘Near-Optimal’ Workflow Results

By applying Leavitt’s Diamond, our optimal model reflects a significant improvement in the efficiency of the EMIO workflow process by reducing the C2 cycle time to approximately 3 hours as compared to the Spiral-1 C2 cycle time of just under 21 hours. This overwhelming reduction in cycle time produced by the optimal model allows for a singular engagement in which all actors involved in the EMIO process, at initial VOI contact, can take appropriate action if needed. As such, our near-optimal POW-ER model provides the tractable and applicable solution to our second thesis question: **What is the optimal Extended Maritime Interdiction Operations command and control structure after Spiral-1 technology implementation?**

V. CONCLUSIONS AND RECOMMENDATIONS

A. CONCLUSION

The art of monitoring vessel traffic throughout the maritime domain is not a new skill practiced throughout the United States. Rather, the act of maritime domain information sharing between multiple governmental agencies in order to achieve comprehensive situational awareness of threats throughout the maritime domain is a new art accomplished under the guise of Maritime Domain Awareness. As such, it is under this perspective in which the Secretary of the Navy has initiated and directed the fielding of a prototype MDA capability which through its first Spiral would provide:

1. A capability to the U.S. Central Command (CENTCOM) and U.S. Pacific Command (PACOM) Areas of Responsibilities (AORs), interagency partners, and select friendly and allied nations.
2. The core effort will create a network that, at multiple levels of security and across multiple domains, will feed many data streams into a common operational picture (COP) accessible throughout the United States Government and foreign or Coalition partners.
3. Be able to handle time sensitive maritime threats.
4. Will be designed for expansion.⁴⁹

Under the new realm of Maritime Domain Awareness exists the mission of Extended Maritime Interdiction Operations which is a small but significant element of MDA. As mentioned in Chapter I, Extended Maritime Interdiction Operations target personnel or material that poses an imminent threat to the United States. Therefore, in order to enhance accessibility to information gathered from EMIO, Spiral-1 technologies designed to streamline information processing capabilities have been procured and are

⁴⁹ “Scoping Document for Navy Maritime Domain Awareness (MDA) Spiral 1 Prototype,” Revised January 2008 – Version 4.3.

expected to be operationally tested by August 2008. However, modeling provided in Chapters III and IV provided the ability to predict operational outcomes.

The current EMIO workflow process to collect boarding data, analyze and transform the data into actionable intelligence, and then disseminate it back to decision makers takes approximately 35 hours as revealed through our modeling simulation. This process is lengthy and fails to improve situational awareness within the Maritime Domain. However, the implementation of Spiral-1 technologies within the EMIO workflow process does add value by reducing the time gap between collection and analysis of data by 14 hours. This significantly improves the efficiency of the EMIO workflow process, yet it does not provide real-time actionable intelligence to decision makers in order to allow for a timely engagement. This leads to the question of what is the optimal EMIO command and control structure.

The ‘near-optimal’ EMIO command and control structure was developed from proven academic philosophies and techniques of Business Process Reengineering and Leavitt’s Diamond. Michael Hammer claimed that reengineering could not be accomplished just by cutting fat or automating existing processes; rather it is accomplished by challenging old assumptions and shedding the old rules that made the business underperform in the first place.⁵⁰ Spiral-1 EMIO technologies address one portion of the inefficiency that exists within the ‘As-Is’ EMIO workflow process, but changes to the current organizational form and people involved in the process completes the reengineering effort. These applications provided guidance in developing a model that takes into account significant changes in processes and organizational structure. We used modeling software to simulate our ‘near-optimal’ EMIO workflow, as well as the other EMIO workflows, to illustrate the drastic improvements that resulted in a reduction of over 30 hours. This new ‘near-optimal’ command and control structure allows for boarding data to be transformed into actionable intelligence that can be acted upon in a timely manner, which increases the situational awareness within the Maritime Domain and supports SECNAV’s initiative.

⁵⁰ Michael Hammer, “Reengineering Work: Don’t Automate, Obliterate.” *Harvard Business Review* (July-August 1990), 4.

B. RECOMMENDED FUTURE RESEARCH

While researching and writing this thesis, we identified several items of future research for students who wish to develop them further. We list the items below.

1. Conduct a performance analysis of the EMIO Spiral-1 technologies in accordance with Spiral-1 MOEs and MOPs.
2. Validate Spiral-1 and Optimal workflow models through future MDA Spiral exercises.
3. Examine EMIO policies and procedures in place to verify uniform guidance and direction in accordance with MDA procedures.
4. Examine alternative MDA and EMIO command and control structures that enhance collaboration efforts.
5. Develop a model to simulate the current MDA 'As-Is' workflow process to identify disconnects and value added process.

THIS PAGE LEFT INTENTIONALLY BLANK

APPENDIX A. MDA CONDUCTED INTERVIEWS

A. INTERVIEW WITH THE OFFICE OF NAVAL INTELLIGENCE

Representatives of the NPS team interviewed several staff of NMIC/ONI 23 October 2007 (Freeman, J., Hutchins, S., 2007). The interviews were structured to elicit comments about (1) a draft workflow for MDA activities surrounding a tracking and E-MIO scenario, and (2) the utility of MDA Spiral 1 technologies for their activities. NPS interviewed: an information systems manager, a Watch Floor COP manager, and a specialist in boarding operations and data. An informal interview was conducted with the head of the Advanced Maritime Analysis Cell, and with the lead for a DoDAF architecture effort focused on the intelligence day shops. All interviews were held at the unclassified level.

Process critique

Informants

- Jim Stallings (jstallings@nmic.navy.mil; 301-669-4407) -- Watch COP/CIF Manager
- Lt Henry Lange (hlange@nmic.navy.mil: 301-669-4324) – MIO Intel Collections
- Paul Carroll

10 VOI Tipper

Notes

- Once determine it is a POI then it becomes a VOI: Deal more w/ people than vessels (Ctr-terrorism)
- Watch floor gathers info in coordination w/ CG on ships coming to CONUS
- A VOI tipper comes in from a vessel or NAVCENT OR we may originate a VOI based on intel, Coast Guard, Ships coming to CONUS with their crew lists. Will increase/decrease accordingly: ONI assigns priority level.
- We tag it (“suspect” merchant) & specify level of priority
- ONI Watch – front line, ones actively working w/ Flts, or in future

- MOQs; Process should also be bottom-up, i.e., outside originators should be pushing info up the chain
- Alert goes out ship ID'd as VOI by watch analyst: Do Daily Updates msg – Intel blurbs concerning that ship/ info on it
- Transmit via GCCS to appropriate AOR to global COP
 - Merchant suspect -- Send to all/ everybody and geo-synch to appropriate AOR. Anything that is suspect is a concern to all.

Workflow diagram

Some of things listed next level down are actually done @ ONI because these org's are very young organizations

- Right now: completely manual process
- To ensure coordination occurs – on watch floor they use a number of chat windows, phone calls, email. Not sufficient to just put in COP
- MOC may reach back to you for additional info; Watch floor analyst will do analysis & handle, or if more in-depth analysis is needed get specific expertise type of analyst (e.g., ctr-narcotic specialist, ctr-terrorist, etc.
- ONI cells - the "day shops" that respond to tough RFIs. ONI develops and disseminates intelligence to operational forces. It consists of several analysis cells (day shops) and a watch floor that interacts directly with the Navy commands to elicit and provide intelligence, typically concerning vessels of interest.

Structure

- ONI 111 – counter-terrorism analysis cell (more people than vessels)
- ONI 112 – counter-narcotics analysis cell
- ONI 113 - SEAWATCH technology owner; data quality control; own SW db
- ONI 114 – counter-proliferation analysis cell
- ONI 115 -- homeland defense cell – diff from Ctr-terror – looking at everything & more domestically focused
- ONI 116 -- intelligence strategy, define the problem sets to look at
- ONI 11? -- watch floor; front line actively tracking; working w/FLT's or, in future MOCs

RFI

Comes in via phone call, chat, email - tracked by watch, sent to whatever "day" shop.

- Easy RFIs – database search, e.g., just looking for picture of vessel, history-route, planned destination
- Hard RFIs – network RFIs, want to know owner of vessel, who vessel is tied to
- ONI RFIs – on whichever is appropriate because of what vessel might be Carrying
- Regional type Q's can give specific info on that country
- Ships may come directly from FLT; are obligated to inform NAVCENT
- NAVCENT Does tasking – will implement anything tactical, but lot of tasking comes from ONI
- Some RFIs get pushed up; RFI directly from sea, i.e., merchant on their COP is red. Will continue tracking once something is tagged, we continue to collect. Primary info is track, but movement on COP.
- Dissemination is from ONI, combining all source data.
- Continue process of tracking vessel; ELINT and other nat'l imagery.

DAILY UPDATE

Includes precursor info and any change info. Publish everything learned in real time & rpt in Daily Update. Depends on priority how fast info gets sent out. Lower priority trks – just publish in Daily Update.

- 20K tracks in db (18K neutrals)
- Classes
- OCONUS bound vessel
- NKorean high interest
- Others
- Communications for 10 via GCCS
- Watch analyst does daily update message re: "merchant suspect" as VOI to NAVCENT MOC
- We also make email, chat

- (For 18K tracks that are legitimate neutrals, we geolocate
- Rate: 220VOImin - 300VOI - 350VOImax
- HR: 13 (crypto (CSG), Elint, coast guard, COP sit managers, AOR desks
- (CENTCOM, PACOM, Americas, EUCOM) but they are under-tasked right now.
- Docs in: standardize record messages, chat, phone, RFI, email from CG
- Docs out: same as in
- Technologies: (see below)
- 20 RFI received via email, chat, phone from NAVCENT or directly from a vessel

Note

- An analyst on the watch floor may answer the easy RFIs. E.g., a db search for a vessel photo, track history, planned destination
- The floor analyst may push hard RFIs to a day shop here, and they track these. E.g., passenger info, ship's owner via counter-terrorism.
- ONI1 (111, 112, 114, 115).
- ONI2 answers questions re: regions. Such as impact of recent events, red forces
- Rate for dayshop RFIs: 2x-3x-4x per week for a day shop
- HR for dayshop RFIs: 1 analyst per RFI
- Rate for floor: 0-6 formal per 24 hours (about 1 hr each) + 15-20 informal, fast RFIs per 24 hours + some internal service for RFIs
- HR for floor: 1 person
- Docs in: see 10
- Docs out: see 10
- 30 RFI response sent directly (cc: watch floor) or via watch floor to both the ship and to NAVCENT

no notes

- 50 ONI continues intel on VOI until the vessel is no longer VOI

Notes

- Principle focus is movement history in daily from ELINT, national imagery
- ONI actively manages intel assets, e.g., sensors to capture data on location, etc.

- Local vessels may add the vessel to the COP. They may or may not push it up to everyone else.
- Rate: often under-tasked
- HR: 1 person
- Docs In: everything (see ONI1) including intellink
- Docs out: ONI web portal "silver tab" at different levels, email
- _?_ ONI publishes daily update on VOIs

Notes

- The update reports what's happened in the prior 24 hours. It will have been reported already for high priority vessels. For lower priority tracks, we hold for the 24 hour update.

60 SEAPORT

Notes

Response from BMFC (pos/neg match) should go to 3 places: Sr. Watch Officer, NAVCENT MOC, and originator.

- If positive, comes to ONI – biometric analysis cell (BAC) (this person acts as a collateral duty)
- If positive, BAC has 3 hrs to send why back to NAVCENT MOC and ___on why it is: Biometric Intel Analysis Report (BIAC). Analysis cell is mobilized to produce report to send back to JIOC.
- CENTCOM and PACOM analysis, 7F are at ONI if there is going to be a hand off, PACOM analysis would take over.
- NAVCENT is required to put all boarding data (results of biometric data analysis done at BMFC, WV) onto SEAPORT, but resource constraints mean that doesn't always happen.
- Should be an automatic flow of all info into SEAPORT – but does not always happen due to operational constraints
- These data come up CNFC Coalition Naval Forces Central or on CMFC = Cooperative Maritime Forces Central

- Seaport is for historical analysis, an archive. The watch floor does not care about these data for real time action except to provide a profile of the vessel.
- Human Resources to conduct: ~300 VOI Tippers handled; about 3/ week
- 13 people on watch floor; everything comes in thru' watch floor from CENTCOM, PACOM, 4 Regional areas: Americas, EUCOM, CG Watch and many info groups (crpto supt grp, elint, CIT mgr, functional desks)
- Currently under-tasked (EUCOM, sometimes CENTCOM) PACOCM over-tasked
- RFI can be formal/ informal; have to take time to dedicate
- 15-20 RFI pass through in given day. Are also answering questions for people in bldg
- Archive: Can be used tactically to see if vsl has been boarded before.
- Can share SEAPORT info across multiple networks and get French ship in vicinity of VOI to board it as it comes up on 96-hr window before U.S.
 - EX: Coalition ship notices tripwires – passed to NAVCENT “Last box on flowchart” NAVCENT Regional Analysts handoff to C7F Regional analysts – happens 2-3 times/ week

Reasons for Process failures (outside ONI)

- So reliant on different networks, track data being shared throughout different components. COP architecture – where does it go? “Crap shoot” as to whether right info gets to right person.
- Segments – because has to go thru COP architecture: hierarchical architecture- at each level it can be filtered out. If CENTCOM sends data down to their component CDRs.
- ONI Has no control over what gets sent back up to ONI.
- Reasons for Process failures (outside ONI):
- Urgent RFI on weekend – if SME is not in bldg, it goes to next best person. From MIO perspective, guy going to send biometric to BMFC did not have rights to send it...

- Watch floor – high turnover, many junior people, not trained in procedures, who's who, who to contact
- MIO – need training on equipment tactical units often do not receive training
- NAVCENT changes policy – going to collect biometrics on every ship boarded: ONI doesn't have manpower to do this
- Training biggest issue re manpower; turn off automated systems, need to train the trainer, fluctuations in people coming in
- Docs in: Contextual data via SEAPORT in jpg, bmp, excel, scanned docs at attachment to Seaport db
- Process: above
- Docs out: Chat, phone, email

63 Biometric data to BFC (Biometric Fusion Center) in West Va.

Notes

- This group identifies known suspects from boarding data
- This is done unclass
- This is a new process
- The data that are transmitted from the boarding party is a digital fingerprint.
- Note that Coalition does not collect biometrics, though they may (source is uncertain) provide images of eqt & radiological.
- The biometrics are returned to ONI watch floor
- NAVCENT MOC
- Tactical force (the boarding party's command)
- Docs In: Digital fingerprint email
- Process: Auto correlation against databases
- Docs Out: Email stating positive match or no match

Biometrics response

Notes

- If there's a positive ID, then ONI responds with an explanation (who they are, why they are suspect) to NAVCENT MOC or Tactical force
- Rate: 1x in 2007 for 25 individuals in one event

- HR: 3-7 part time
- Docs In: see 63

Docs Out: Biometrics Intelligence Analysis Report via email attachment

67 NCIS role --

Notes

- This informant had no info on the NCIS & law enforcement role
- CAPT Boyd runs the identify management office that is trying to integrate law enforcement databases.

80-110

Notes

- ONI does have regional analysts
- If a vessel is headed between AORs, then there'll be a handoff between our analysts here.
- Rate: 2-3x per week
- HR: 2 regional specialists involved
- Docs in: Sealink, SEAPORT, GlobalTrader,
- Technologies: Anticipated technologies at ONI
 - Note: None of these technologies have been run through the official ONI process for fully accrediting a system. A previously accredited system can enter ONI through its process in 90 days. For a non-accredited system like these it could take 6 months.
 - Note: Almost all ONI data move at SCI level. We downshift the data to a lower classified domain (which strips off the sources).
 - Note: None of the technologies
 - Note: Where is GCCS? Where are other programs of record?
- EMIO CENTRIX CFMC is running at ONI. Another CENTRIX -- CMFP -- network is 2 months into its 6 month process. This is a useful technology. The procedure for routing EMIO data is not yet settled (e.g., does it go directly from ship to ONI or via NAVCENT or others).
- Use in: Input to 60, 63 (but it's not in those nodes)

- COP – graphical representation of record message traffic; architecture issue because built for geography. When ships transit from CENTCOM -> EUCOM, or GULF to MED, COP not built to include data when track transits. Limited to 19-20 tracks: impacts ONI every 48 hrs. Don't send all these tracks to everyone: CENTCOM –just send trks that pertain, same for EUCOM.
 - System is not built to “gracefully” announce “here comes a VOI.” There's a gap between one geo area and the next.
- Advanced Maritime Analysis Cell (AMAC)- people on watch floor use wide variety of tools: websites, phone calls, automatic merchants reporting system, SELINK, SEAPORT, Global Trader, etc.
- TRIPWIRE is working at ONI. It originated here in their analytic cell. This is a useful technology.
- Use in: 20
- MAGNET is nominally operating for the CG now
- Use in:10
- LINX will not be in this building. NCIS only will own it.
- Use in: 63 and/or 67
- CMA is available in NMIC via Coast Guard. ONI will take advantage of it.
- This is a JCTD. Not clear how this relates to GCCS. Another source for vessel tracking.
- Use in: unknown
- TRIPWIRE (aka TAC)
- Use in: 10, 25 (do the analysis), 40 (continuous analysis)
- TAANDEM is an early PANDA. Not clear if ONI will have it.
- FASTC2AP is not in ONI, though some want to move it in here.
- GoogleApps / Fusion Server is not in ONI and not on our horizon.
- GCCS -- GCCS processes vessel tracks in the form of a COP.
- COP is used in briefs and throughout the day.
- Upcoming version will support unlimited number of tracks.
- GCCS successes

- Keeps the COP up
- Users can see the vessels anywhere in the world, threat and friendly
- GCCS weaknesses
- Installing version updates is problematic
- Minor latencies, on the order of seconds
- Interference (distance between vessels) and travel times is underused
- Failure points
- Track data in GCCS is not always shared between nodes because data needs to pass through the hierarchy of COPS and it can be filtered out at each level. E.g., If PACOM doesn't send data down to its component commanders, then it doesn't get there. A tactical unit may not pass this up.
- An urgent RFI on the weekend may not be quickly answered if the SME is not in the building. From the EMIO perspective, a guy
- A unit may not have permissions to send a large file to the biometric center. So now he needs to get new permissions.
- Training: Watch floor has high turnover of personnel means procedures, contacts may not get used right. In EMIO work, the tactical units are using eqt they have no training on and rarely use.
- Manpower to analyze biometrics, here at ONI, is limited.
- Non-cooperative targets may turn off data sources. So we may lose them. We need to anticipate where they'll be.
- Training in general: There's one guy (our informant) who does this training of trainers who return to their ships with new knowledge. Little Creek has begun to help with this.
- Turnover: Watch personnel turn over frequently.
- Re: 100 -- The system doesn't support early notification of handoffs between AORs. During a recent handoff, EUCOM and CENTCOM were handing off vessels during the Lebanese/Israeli war. But the COP didn't enable them to represent that their AORs overlapped. We needed to change our system to represent the overlap between fleet AORs Current COP architecture has a limit of

20K tracks. To stay in that limit, we draw a line. They have no foresight into incoming tracks. At any rate, we need to phone the command to alert them that there's an incoming VOI.

Misc

- ONI also executes some NAVCENT tasks
- Ships may come directly to ONI, but we need to notify the NAVCENT in order recommend a tasking of the vessels
- Vessels on 96 hours of arrival appear on a list
- A story: A French Boarding party notices some suspicious characters. A US ship arrives to take biometrics. The biometric analysis cell of 7 staff
- Advanced Maritime Analytic Cell develops advanced techniques & integrates new technologies. They are skunkworks

Futures: Advanced Maritime Analysis Cell

Informants

- CDR Jim Ford -- AMACs TRIPWIRE, develop analytic techniques. They'll test new concepts with new procedures, new tools.
- (Tom Darby)

Objective:

- Develop new methods and technologies to help the Navy track people and predict intent. Integrate these into ONI and Navy intel.
- Current ONI MDA methods
- Methods vary between ONI11x's. All their methods boil down to reading and reporting
- In contrast ELINT, SIGINT have a formal process. However, they're applying it to an easy problem: tracking 180,000 vessels

Issues

- Threat tip triage -- The challenge is to identify bad needle in the stack of suspect needles. We get huge amounts of threat data. But we have to figure out which to pursue.

- Identifying suspect individuals -- Bad vessels don't kill people. Bad people kill people. So, we need to figure out who are suspects. We cannot just infer that a vessel with opium on it is owned by an evil man. He may not know.
- Data are sparse -- Entity, relationships, attributes are the keys of our work. These data are sparse.
- Data aggregation over sources & over time & knowledge aggregation from it
- Technology goals
- Exploitation of structured and unstructured data in a single analytic environment through geospatial, temporal, semantic -- Difficult to get analysts to think n-dimensionally so that the CDR can place assets proactively. You need to understand the confluence of poppy harvest, Ramadan, ship schedules, politics of bribery at the docks. Analysts have been hampered by their tools that prevent them from thinking in this way.
- Integration of tools -- We have 7 date formats, 15 logons, etc.
- Universal access (civilian, misc) OR Seamless data exchange (even if we're not using the same tools) -- This would give me in ONI what I get from iGoogle.
- Technology products thus far
- TRIPWIRE
- Paelomon
- Intellipedia -- an intel wikipedia is our best tool. It is our best Cumulative Knowledge Base. Wants this to be ubiquitous

Critiques

- Google Apps -- Supports collaboration. But people mainly use it to get to their current file structure. It does not improve it.
- Google Fusion -- Not surprising. I can already get ship tracks on Google Earth. It's not remarkably better data. It provides only visualization, but no analysis (e.g., prediction)
- PEO C4I keeps giving me more information feeds. It was overwhelming to analysts. They never gave me tools to manage it. What to do w/ 17 predator feeds

when I cannot handle one. Chat just injects more people into my busy day. We set up shadow chat services to avoid voyeurs. What if we give this to foreign nations.

Misc

- Develop the intel that eventually produces a VOI tipper. Focused on the difficult problem of identifying which vessels to find, fix, and finish.
- You may care about a vessel moving between two points because you got HUMINT indicating that an opium shipment between those points is pending. You get this intel by chance. You may or may not have a name of a person of interest.
- The biometrics guys assume you can get fingerprints to identify suspects. This assumes that all suspects are printed and that they're in the db you are examining.
- An improved certification, accreditation, T&E process is greatly needed.

B. INTERVIEW WITH NAVAL CENTRAL COMMAND

Representatives of the NPS team interviewed several staff of NAVCENT 11-15 November 2007 (Freeman, J. and MacKinnon, D., 2007). The interviews were structured to elicit comments about (1) a draft workflow for MDA activities surrounding a tracking and E-MIO scenario, and (2) the utility of MDA Spiral 1 technologies for their activities. NPS interviewed: the ONA Director (N2), the Deputy ONA Director (N2), a Communications Information Systems officer (N6), an Information Management Officer (N6IM), the Deputy Director of Future Plans, ONI's embedded analyst in the ONA, an ONA MIO specialist, and several representatives of the COPS. All interviews were unclassified.

Executive Summary

1. Workflow modeling of the NAVCENT MOC is complete. It contains tasks, actors, decision points, and communication flows. It also contains recommended SP-1 uses among tasks.
2. MDA is being accomplished by NAVCENT today using GCCS-M, CENTRIX, SIPR, JWICS, NIPR, SEAPORT, and EHF command nets. "As-Is" workflow

analysis indicates that the remainder of SP-1 is not fielded and therefore few personnel know each technology's features or can understand how to implement them.

3. Watchfloor personnel would more prefer any technology that triggers or alerts them to specific tracks. They are less likely to use a technology that requires data mining or lengthy fusing of multiple sources.
4. As SP-1 technologies are fielded, they need to be accompanied by either: more personnel, training, or at least, easy-to-understand user's manuals, billet-specific tutorials, and some guidance concerning required maintenance.
5. Other areas of concern are: reliability, sharability (releaseability), and bandwidth. Reliability concerns can be addressed via improved maintenance and improved technology quality. Sharability concerns seem less easily solved. NAVCENT operates in a Coalition environment with a large number of bilateral agreements. Yet many systems provide fused intelligence that can only be "seen" by U.S. forces. Making any subset of these data available to Coalition partners requires that a special process ("bustering") be invoked. Bandwidth at NAVCENT is not unlimited. If SP-1 technologies require more bandwidth, they will likely remain offline unless they offer greater performance benefits than existing technologies
6. SP-1 technologies may be better deployed for use at a JIOCC or ONI given the extraordinarily high turnover rate at NAVCENT (10% per month on average), the relative shortage of personnel, and the burden of other MOC missions (below). There is ongoing discussion about this option and that it would provide the same tipper information and also provide command agility in the event of flag embarkation away from NAVCENT. NAVCENT would therefore need to work closely with ONI to ensure mission focus is shared and regularly updated. ONI would also need to remain reachable at all times.
7. NAVCENT has three primary missions of maritime security, anti-terror, and IRAN. MDA supports these missions, but it is subordinate to them.
8. SP-2 inputs include a method to combine shore-based radar output among many nations, combined with AIS tracks- and enable this data to be used by the entire

Coalition. This capability aligns with the MOC N2's vision for enhancing both the capability of the MOC and the strength of partnerships in the region.

Participants

Dr. MacKinnon and Dr. Freeman interviewed the following individuals at NAVCENT:

- LCDR Dan Bethel, N6IM, Information Management Officer, (o) 318-439-9538, (c) 973-1785-9538, (cell) 973-394-8382, (recently transferred)
- CDR Danny Sadoski, N6, Communications Information Systems (provides hardware and Information Assurance to the fleet), danny.Sadoski@me.navy.mil, (o) 318-439-4590, (c) 973-1785-4590
- CAPT Wayne Porter, N2, ONA Director, (o) 318-439-9469
- LCDR Phil Ohlenmeir, COPS Officer, philip.ohlemeier@me.navy.mil, (o) 318-439-3814
- LCDR Chris Roby, Christopher.robby@me.navy.mil, (o) 318-439-3879
- CDR Curtis Dunn, Deputy N2, curtis.dunn@me.navy.mil, (o) 318-439-4132
- Mrs. Rebecca Norfolk, ONA, ONI embedded analyst, rebecca.norfolk@me.navy.mil, (o) 318-439-6024 (soon to transfer to ONI)
- Chief Angela Ahsue, angela.ahsue@me.navy.mil, (o) 318-439-3068
- CDR Chuck Vickers, EOD Officer, Deputy Director Future Plans Center, (o) 973-1785-4089, (c) 318-439-4089, (cell) 973-3930-1684
- LCDR Alexander Gonzalez, ONA MIO (intel and former Coast Guard MDA), Alexander Gonzalez@me.navy.mil, (o) 318-439-6022.

Note: (1) Most email addresses above can be rewritten as SIPRNet addresses by replacing me.navy.mil with me.navy.smil.mil. (o)=office phone, which should be dialed 1-011-973... (c) = commercial or DSN phone.

NAVCENT MDA Process

The participants substantially refined the NPS MDA workflow model⁵¹. The diagram below presents the MDA process in three stages corresponding to Observe and Orient (top box), Decide, and Act. Most nodes in this diagram contain (1) a numeric tag for the task, (2) a short title for the task, (3) a brief description of the task, (4) notes concerning current technology or other issues, (5) the Spiral 1 technologies deemed useful for the task by the participants. Each arc indicates the principal media for communicating information between tasks. Rectangular nodes indicate tasks conducted in the MOC. Elliptical nodes indicate tasks conducted by entities outside the MOC.

⁵¹ The workflow diagram presented here was generated using AT&T's public domain graphics package, Graphvix. The data are drawn from an Excel table. Dr. Freeman can edit the data and regenerate this graph, or it can be transferred to another application as needed.

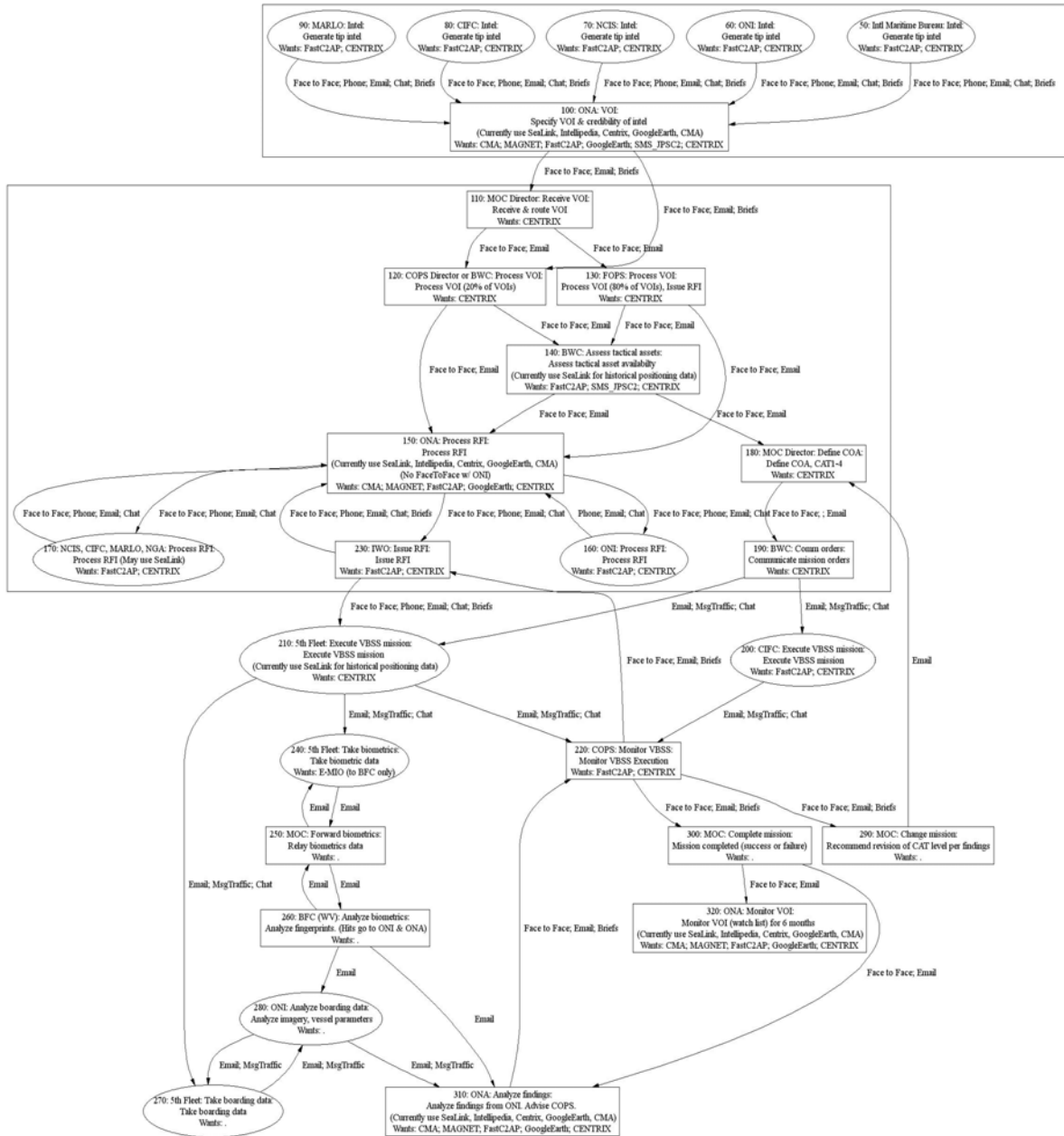

The MDA process is rarely invoked in the MOC. In the months preceding the team’s visit, only one VOI was received and processed to a tactical action. This is typical of the monsoon season. In the immediate future (following monsoon season), the MOC anticipates processing as many as 4-10 VOIs per month. These are handled amidst the main, mission duties of the MOC, which are to support efforts regarding Iran, Maritime security (piracy, drugs), and the anti-terror.

Despite the current paucity of MDA tasks, the potential MDA workload is quite high. CAPT Porter reported that there are 9,000 tracks in the system at a given time, and another 30,000 that are not because they don't have AIS. Integrating coastal radar into the MDA data would make many of the 30,000 unmonitored tracks available, but would demand either that they be tracked outside the MOC (e.g., at ONI) or that sophisticated anomaly detection, tracking, and alarm technology be available in the MOC.

Note that VOIs delivered to the MOC can be processed on a fast route (through COPS) or a slower route (through FOPS). VOIs on the fast route can be processed in as little as two hours. (The time course for the slow course runs days to months. We did not develop a time course for these or other tasks). Specifically, the time course for rapid processing is:

Task ID	Task	Duration
110	Receive VOI	10min
120	Process VOI	10min
140	Assess tactical assets	20min
180	Define COA	30-60min
190	Comm orders	30min

Issues and Potential Points of Failure in NAVCENT MDA Process

The participants identified several potential points of failure in the current MDA process:

- Who knows what – Individuals with important information may not realize the value of their information and pass it to the team in a timely manner.
- Classification – The CIFC can receive only receive information at or below the level of Releasable to REL/CMFC or below. Systems that operate above this level (e.g., on SIPRNet, off CENTRIX) complicate coordination.
- Firewall – Moving documents from a classified system to another system (“busting”) is a time-consuming step in moving data to partners.
- Translation – Translating data and translating in conversation hinders coordination.
- Chop Chain – The transition to the MOC architecture doubled the number of O6. Thus, it can take days to approve documents where it used to take hours.

- Portability – Systems must be portable to in the event of warfighting.
- Insufficient intelligence – When intel is not sufficient, decisions are more difficult to make well
- Insufficient assets – There is a limited number of ships, aircraft, on-board linguists, biometrics gear, transmission equipment, and other assets.
- Partner policies – Partner policies concerning the use of assets sometimes limits ability to act when and where needed.
- Turnover – Personnel new to the watch may not request or deliver sufficient information for decisions.
- Tracking – Tracking is difficult because smugglers turn off emitters, and so we're forced to task limited assets to find suspect vessels, or to forego pursuing certain VOIs.
- ONA/N2 (Capt Porter's) vision is compiled below.
 - GCCS nations don't trust each other, but they have common fear of Iran right now.
 - So, we want to get the big Sunni on the block to play a major role. This would force a multinational agreement.
 - We have 150 instead of NATO here. We have the CIFIC
 - We need to develop an unclas baseline we can share.
 - We would build a Global Counter Terrorism classification (Secret Lite) version that we can release to our partners here on bilateral or multinational.
 - The Volpe Center (in Mass) feeds AIS data to Italy. 36 countries contribute data to this, such as coastal radars and transmitters. This all runs through a secure socket layer Web access. It is inexpensive. Correlation of these data is done in Verona. In Naples, it goes into GCCS where anomaly detection gets done.

- I want the Saudis to host a similar system. It would feed the CIFC we layer on stuff that goes tot he coalition. It would feed our MOC, where we layer on bilateral or data for our own vessels.
- East Africa is enthusiastic about this because it lets them leverage the coastal radar data they have.
- Yemen is interested because they are acquiring Italian Coastal radar.
- They're compatible w/ Italian systems, so we seal the seam in that area

C. PERCEIVED UTILITY OF MDA SPIRAL 1 TECHNOLOGIES

Three sets of data provide some insight into the perceived utility of Spiral 1 MDA Technologies as voiced by the participants in these interviews: a tally of preferred technologies, a tabular mapping of those technologies to specific tasks and performers, and the participants’ rationale for these technology preferences. We present these data in the tables below.

The following table presents the number of tasks for which each Spiral 1 technology may have utility in the opinion of at least one participant in the NAVCENT interviews. The large number of tasks to which CENTRIX can be applied may be due to its utility for coalition communications. Respondents are also highly familiar with CENTRIX; it is currently in use at the NAVCENT MOC.

Spiral 1 MDA Technology	Count of tasks
Tripwire	0
GoogleApps	0
GoogleEarth	4
LINX	0
SMS_JPSC2	2
SEAPORT_CAS	0
E-MIO	1
CENTRIX	21

The mapping of Spiral 1 MDA technologies to specific tasks, and of current communications media to tasks is presented in the workflow diagram, above. However, the reader may find it easier to digest these data in tabular format:

Task ID	Task_Name	Performer	CommMedia	Technology
50	Intel	Intl Maritime Bureau	Face to Face; Phone; Email; Chat; Briefs	FastC2AP; CENTRIX
60	Intel	ONI	Face to Face; Phone; Email; Chat; Briefs	FastC2AP; CENTRIX
70	Intel	NCIS	Face to Face; Phone; Email; Chat; Briefs	FastC2AP; CENTRIX
80	Intel	CIFC	Face to Face; Phone; Email; Chat; Briefs	FastC2AP; CENTRIX
90	Intel	MARLO	Face to Face; Phone; Email; Chat; Briefs	FastC2AP; CENTRIX
100	VOI	ONA	Face to Face; Email; Briefs	CMA; MAGNET; FastC2AP; GoogleEarth; SMS_JPSC2; CENTRIX
110	Receive VOI	MOC Director	Face to Face; Email;	CENTRIX
120	Process VOI	COPS Director or BWC	Face to Face; Email;	CENTRIX
130	Process VOI	FOPS	Face to Face; Email;	CENTRIX
140	Assess tactical assets	BWC	Face to Face; Email;	FastC2AP; SMS_JPSC2; CENTRIX
150	Process RFI	ONA	Face to Face; Phone; Email; Chat;	CMA; MAGNET; FastC2AP; GoogleEarth; CENTRIX
160	Process RFI	ONI	Phone; Email; Chat;	FastC2AP; CENTRIX
170	Process RFI	NCIS, CIFC, MARLO, NGA	Face to Face; Phone; Email; Chat;	FastC2AP; CENTRIX
180	Define COA	MOC Director	Face to Face; ; Email;	CENTRIX
190	Comm orders	BWC	Email; MsgTraffic; Chat;	CENTRIX
200	Execute VBSS mission	CIFC	Email; MsgTraffic; Chat;	FastC2AP; CENTRIX
210	Execute VBSS mission	5 th Fleet	Email; MsgTraffic; Chat;	CENTRIX
220	Monitor VBSS	COPS	Face to Face; Email; Briefs	FastC2AP; CENTRIX
230	Issue RFI	IWO	Face to Face; Phone; Email; Chat; Briefs	FastC2AP; CENTRIX
240	Take biometrics	5 th Fleet	Email;	E-MIO (to BFC only);
250	Forward biometrics	MOC	Email;	
260	Analyze biometrics	BFC (WV)	Email;	
270	Take boarding data	5 th Fleet	Email; MsgTraffic;	
280	Analyze boarding data	ONI	Email; MsgTraffic;	

290	Change mission	MOC	Email;	
300	Complete mission	MOC	Face to Face; Email;	
310	Analyze findings	ONA	Face to Face; Email; Briefs	CMA; MAGNET; FastC2AP; GoogleEarth; CENTRIX
320	Monitor VOI	ONA	Email;	CMA; MAGNET; FastC2AP; GoogleEarth; CENTRIX

Participants varied in their assessments of the potential utility of MDA Spiral 1 Technologies. We provide their detailed comments here.

Participant	Billet	Technology	Assessment	Benefits
Ohlemeir	COPS	CENTRIX	Useful	Chat and email are useful. However, it crashes often.
Sadoski	IS	CENTRIX	Useful	Server replication, low bandwidth, and chat are the main benefits. "We wouldn't operate tactically without it."
Norfolk	ONA	CENTRIX	Useful	Chat and product posting between coalition partners.
Bethel	IS	CENTRIX	Useful	Browse, email, chat. All of this this via dial in and direct feed.
Ohlemeir	COPS	CMA	not useful	Historical data is too detailed for use in the MOC.
Sadoski	IS	CMA	Useful	Interoperability and commercial availability to other countries are the main benefirst.
Norfolk	ONA	CMA	Useful	Tactical level data, including pictures, accessible to coalition. However: It needs ability for users to input pictures so that we don't have to ask that AARs be submitted both to Seaport and via other media. Needs Adobe so that you could generate reports in record message format.
Bethel	IS	CMA	not useful	Can't share it.
Ohlemeir	COPS	E-MIO Wireless	(useful but not in MOC)	Relieves MOC of role of forwarding biometrics. Not useful in the MOC however.
Sadoski	IS	E-MIO Wireless	useful	
Norfolk	ONA	E-MIO Wireless	useful	
Bethel	IS	E-MIO Wireless	(useful but not in	Biometrics wireless to satellite to WV will be much faster than the

			MOC)	current method of going through the COPS. Safety to the boarding crew is key, as is updating the dbs.
Ohlemeir	COPS	FastC2AP	useful	
Sadoski	IS	FastC2AP	useful	(see MAGNET)
Norfolk	ONA	FastC2AP	useful	(see TAANDEM)
Bethel	IS	FastC2AP	useful	Easy to use and to put on GCCS. Loads fast.
Ohlemeir	COPS	Google Apps	not useful	No need for real time collaboration
Sadoski	IS	Google Apps	useful	Support for simultaneous collaboration may be useful
Norfolk	ONA	Google Apps	not useful	Simultaneous editing is not done here. There's a serial business process for document review.
Bethel	IS	Google Apps	not useful	Why use it if we have NCES
Ohlemeir	COPS	Google Earth	tbd	
Sadoski	IS	Google Earth	useful	Provides a common operational picture for all partners
Norfolk	ONA	Google Earth	useful	Imports any data, notably SIGINT. Offers better manipulation capability.
Bethel	IS	Google Earth	useful	Used here class & unclass for fresh data for BDA (4-5 hours). Not for putting tracks on.
Ohlemeir	COPS	LINX	not useful	
Sadoski	IS	LINX	useful	Historical data is useful
Norfolk	ONA	LINX	(useful but not in MOC)	Historical data on suspects is useful, but primarily a tool for ONI.
Bethel	IS	LINX	useful	Highly valued.
Ohlemeir	COPS	MAGNET	useful	Potentially useful for Indicators and Warnings, and in ONA.
Sadoski	IS	MAGNET	useful	User definable alarms are a valuable feature, if policy allow us to set them.
Norfolk	ONA	MAGNET	useful	Potentially a useful substitute for SEALINK (used at ONI)
Bethel	IS	MAGNET	tbd	tbd
Ohlemeir	COPS	SEAPORT_CAS	not useful	Not much collaboration takes place on watch
Sadoski	IS	SEAPORT_CAS	useful	Automatic updates of data are the most valuable feature.
Norfolk	ONA	SEAPORT_CAS	not useful	Can't add our own data (had to

				create a website for that), and the bandwidth savings it brings is not useful.
Bethel	IS	SEAPORT_CAS	tbd	Classified, so I can't share with collaborators
Ohlemeir	COPS	SMS_JPSC2	useful	Port & coastal surveillance
Sadoski	IS	SMS_JPSC2	tbd	If this can share coastal radar between countries, it may be useful
Norfolk	ONA	SMS_JPSC2	tbd	tbd
Bethel	IS	SMS_JPSC2	tbd	tbd
Ohlemeir	COPS	TANDEM	not useful	Perhaps useful at ONI or ONA.
Sadoski	IS	TANDEM	tbd	Not clear if this is useful as they have no technology like this now.
Norfolk	ONA	TANDEM	useful	Anomaly detection in merchant shipping. Probably better done at ONI where they have full time, experienced personnel and relevant databases.
Bethel	IS	TANDEM	tbd	Not a user friendly
Ohlemeir	COPS	Tripwire	tbd	May be useful at ONA, but not on the watch floor.
Sadoski	IS	Tripwire	useful	Useful for US forces. However, policy by European forces prohibits use of biometrics.
Norfolk	ONA	Tripwire	tbd	tbd
Bethel	IS	Tripwire	useful	tbd

Participants provided several general requirements of Spiral 1 technology:

- Personnel – Staff must be provided to operate the technology, to the extent that it supplements existing technology
- System installation process – CENTCOM must give approval to the installation of new technology. This is a sound policy for ensuring interoperability, among other things.
- Robust user interfaces & processing – Systems should return results even given incomplete or slightly incorrect data, and user interfaces should support incomplete entry of data.
- User manuals

- Tutorials – Instructional tutorials targeted at MOC tasks are needed to bring operators up to speed
- Bandwidth – Bandwidth must be sufficient to compensate for any additional load imposed by the technology
- GCCS compatibility
- CENTRIX compatibility
- Maintenance – New technology should come with Planned Maintenance System cards. These are required to ensure that new technology keeps working.

D. LAYOUT OF THE MOC (COPS)

Members of the MOC (COPS) provided information concerning the layout of the MOC watchfloor. It is represented graphically below.



On Wall – four large displays (GCCS-M, CNN, and two others blank, but available)

Front Row

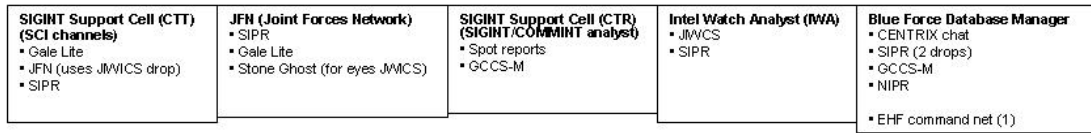

Second Row

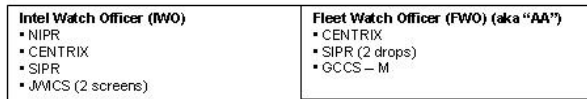

Back Row

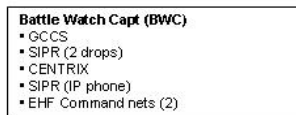

Each of these are displayed by location and each of the technologies are shown in the order they appear (left to right).

Data were gathered that extended the MDA workflow model. In addition, the interviewees raised several issues related to MDA Spiral 1 technologies:

- MDA supports, but is subordinate to the primary missions of NAVCENT: maritime security, anti-terror, and Iran. The prospect of receiving Spiral 1 technologies sparked several concerns: the relevance of the technology effort to primary missions, the shortage of personnel and high rate of turnover (10% monthly), concerns about training staff to use technologies effectively for NAVCENT billets and processes, concerns about system reliability and maintenance, the possibility of reduced manning as a result of MDA automation, and the prospect that the Flag might embark from NAVCENT. These concerns have led NAVCENT leadership to consider whether many MDA activities and Spiral 1 technologies should be housed at a JIOC or at ONI, provided that those institutions can reliably maintain

awareness of NAVCENT's mission focus. That said, NAVCENT leadership views positively the Spiral 2 initiative to combine the shore-based radars of many nations with AIS data. This capability would benefit operations in the MOC, and also strengthen partnerships in the region.

- The knowledge of the Spiral 1 technologies among NAVCENT staff (at the time of the interviews) was scant, and so they had limited ability to assess the utility of these technologies. Watchfloor personnel see value in technologies that triggers or alerts concerning specific tracks. They state that they are unlikely to use technologies that require data mining or fusion across multiple sources.

THIS PAGE LEFT INTENTIONALLY BLANK

APPENDIX B. WORKFLOW DIAGRAMS

A. WORKFLOW PROCESSES

On Scene Commander

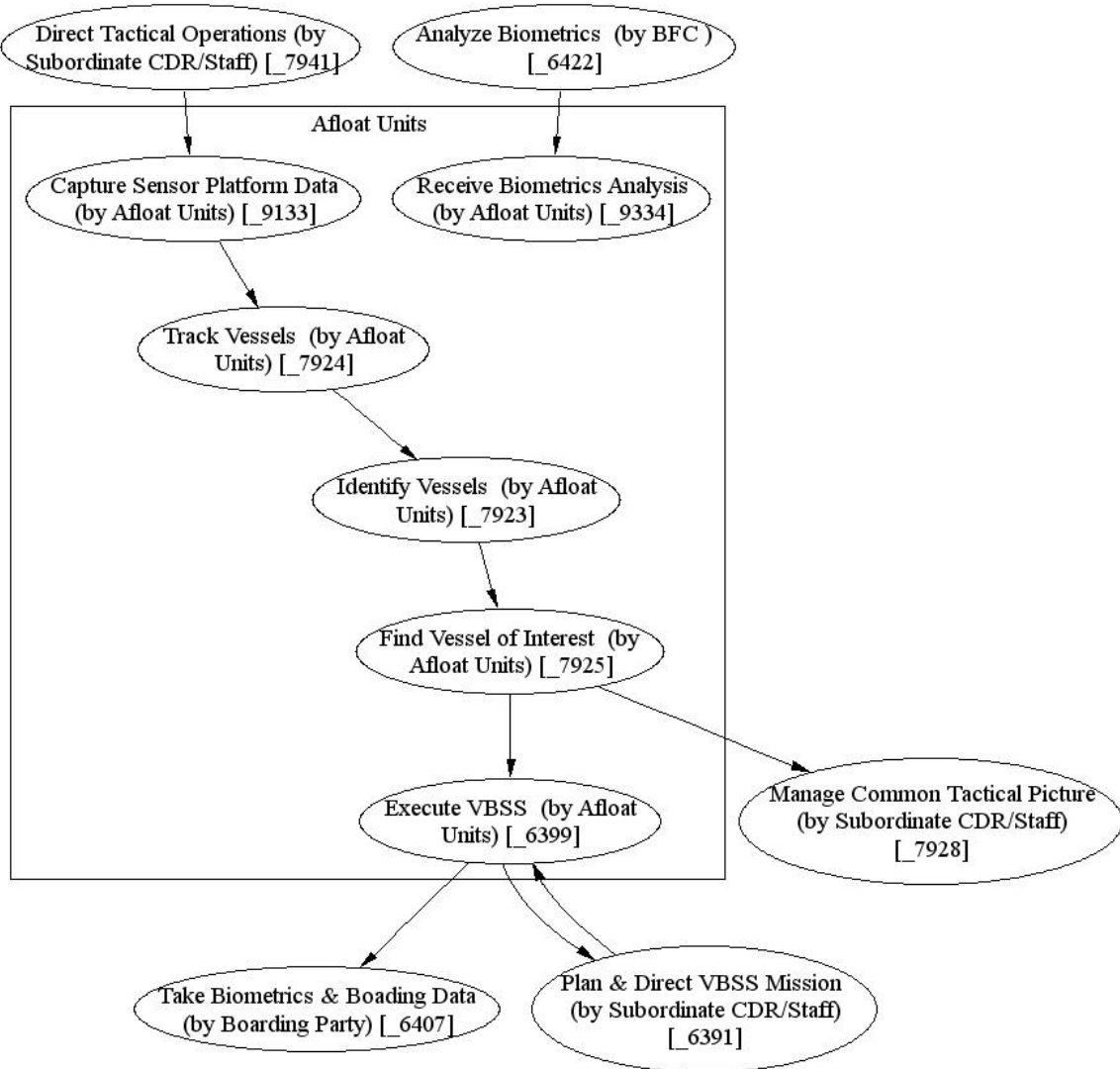

Boarding Party

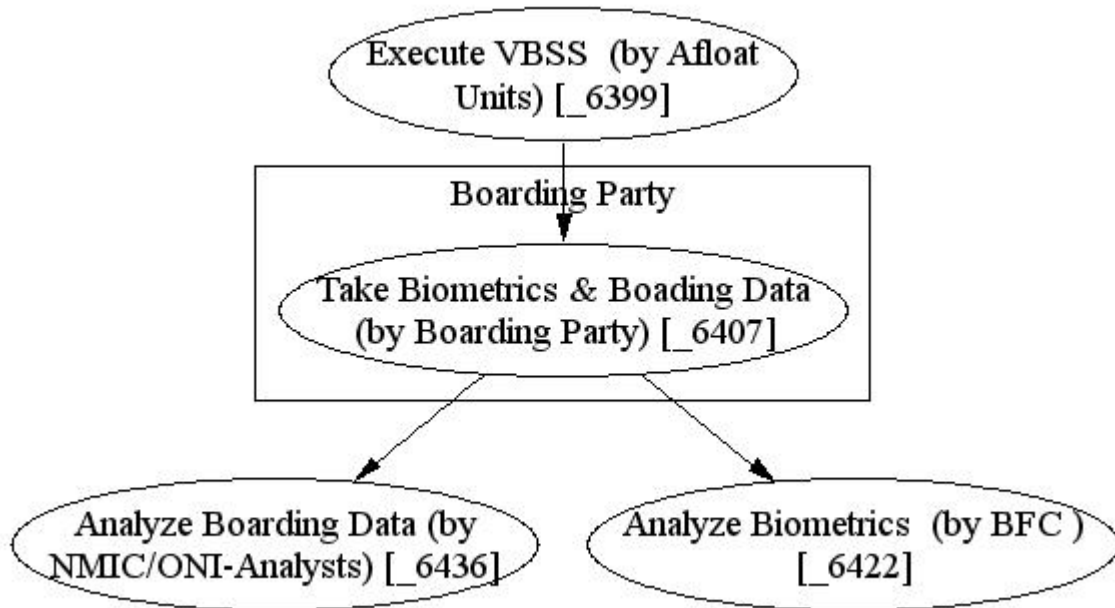

Coalition Forces Intelligence Center

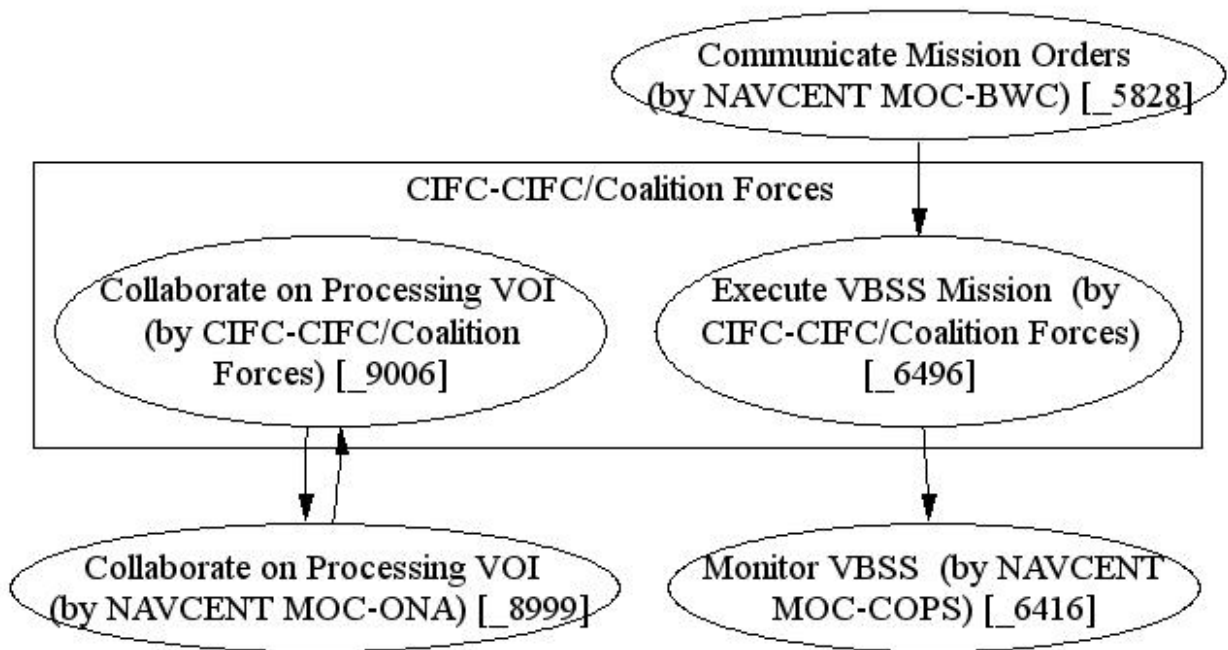

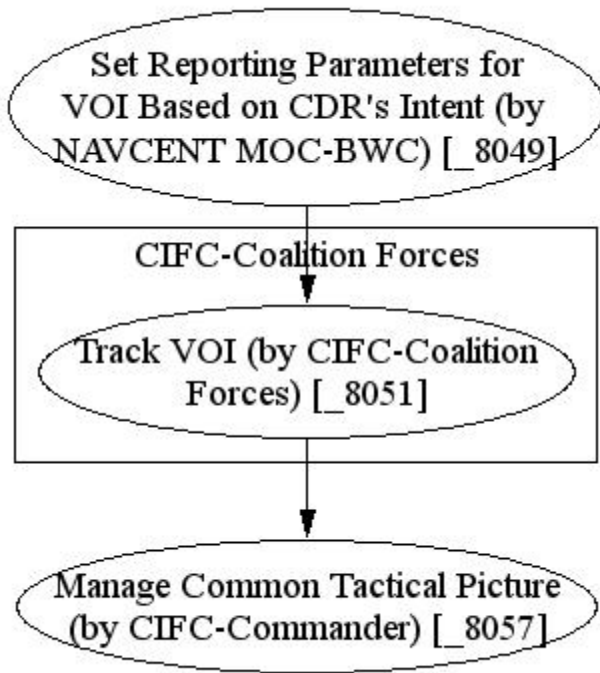

CFIC Commander

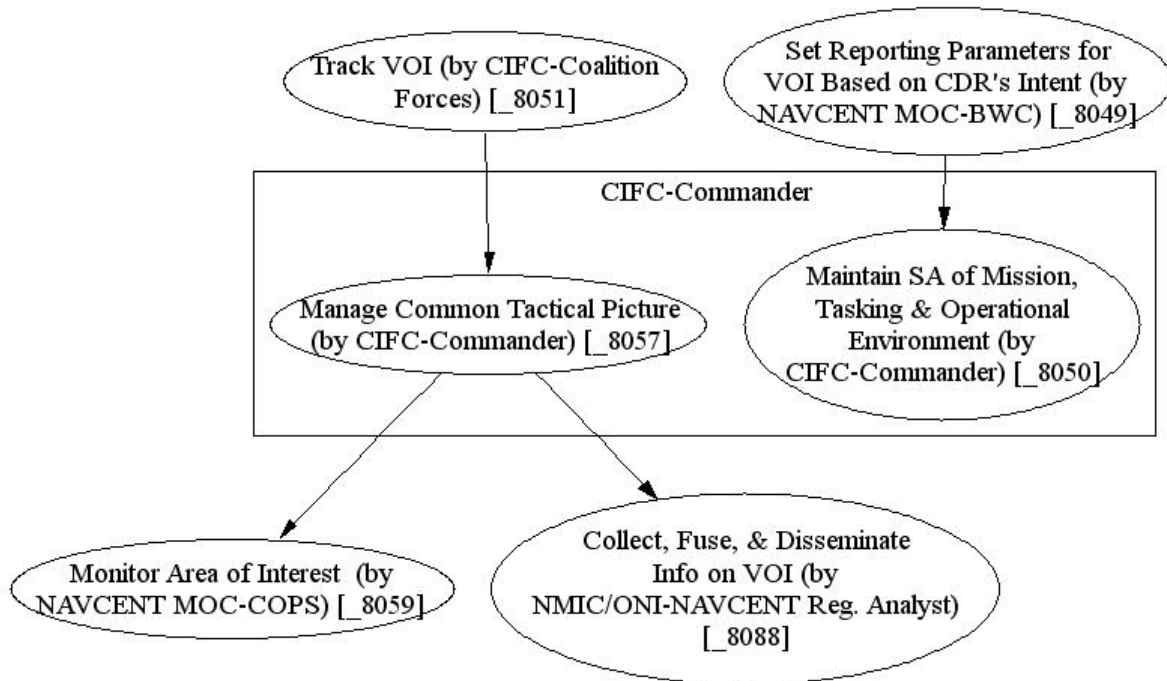

BWC

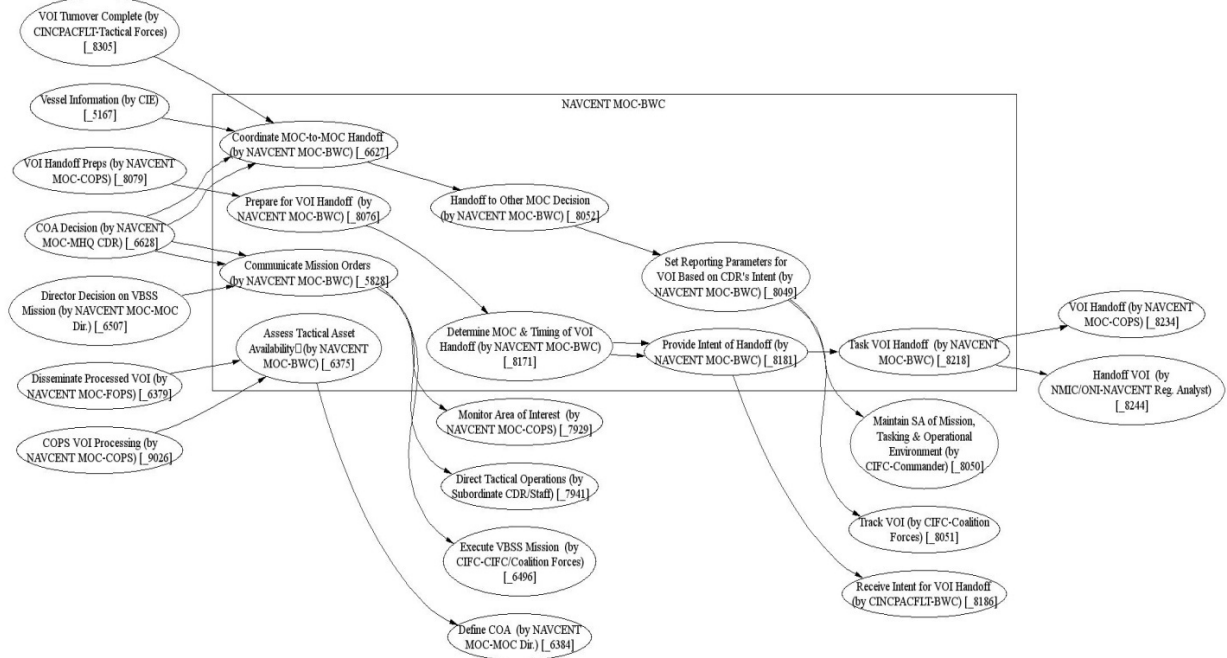

COPS



ONI

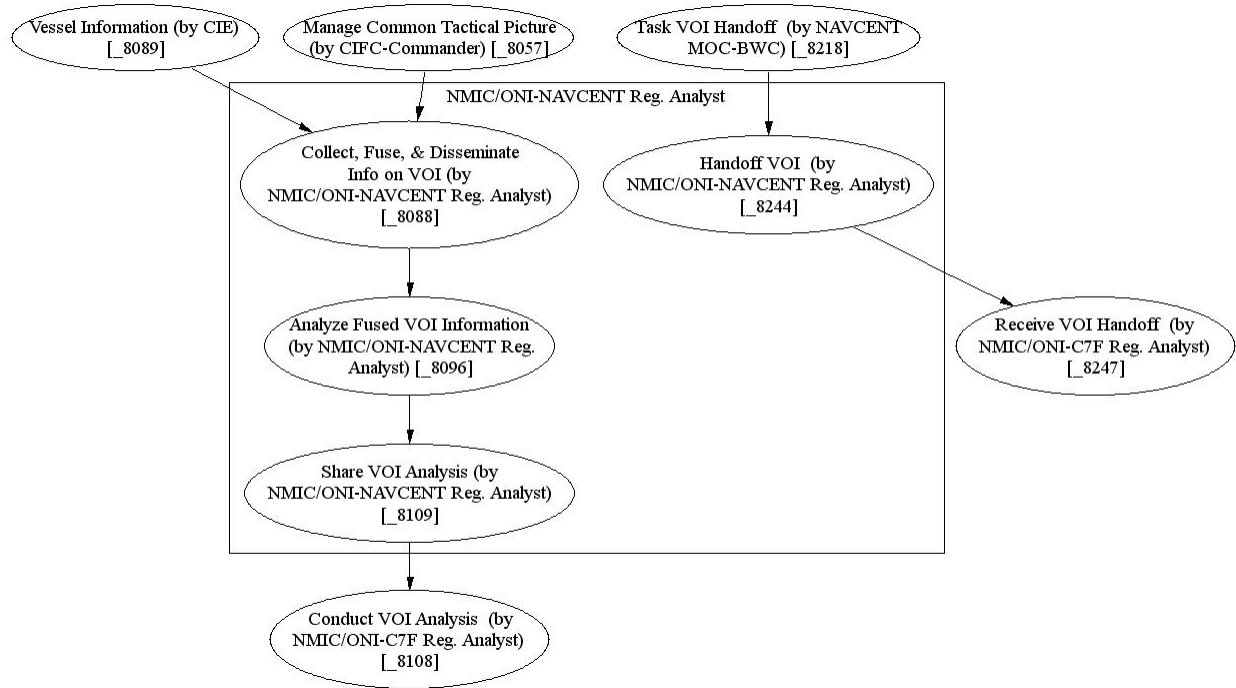

B. DEPARTMENT OF DEFENSE ARCHITECTURE FRAMEWORK

OV-6 Top Level View

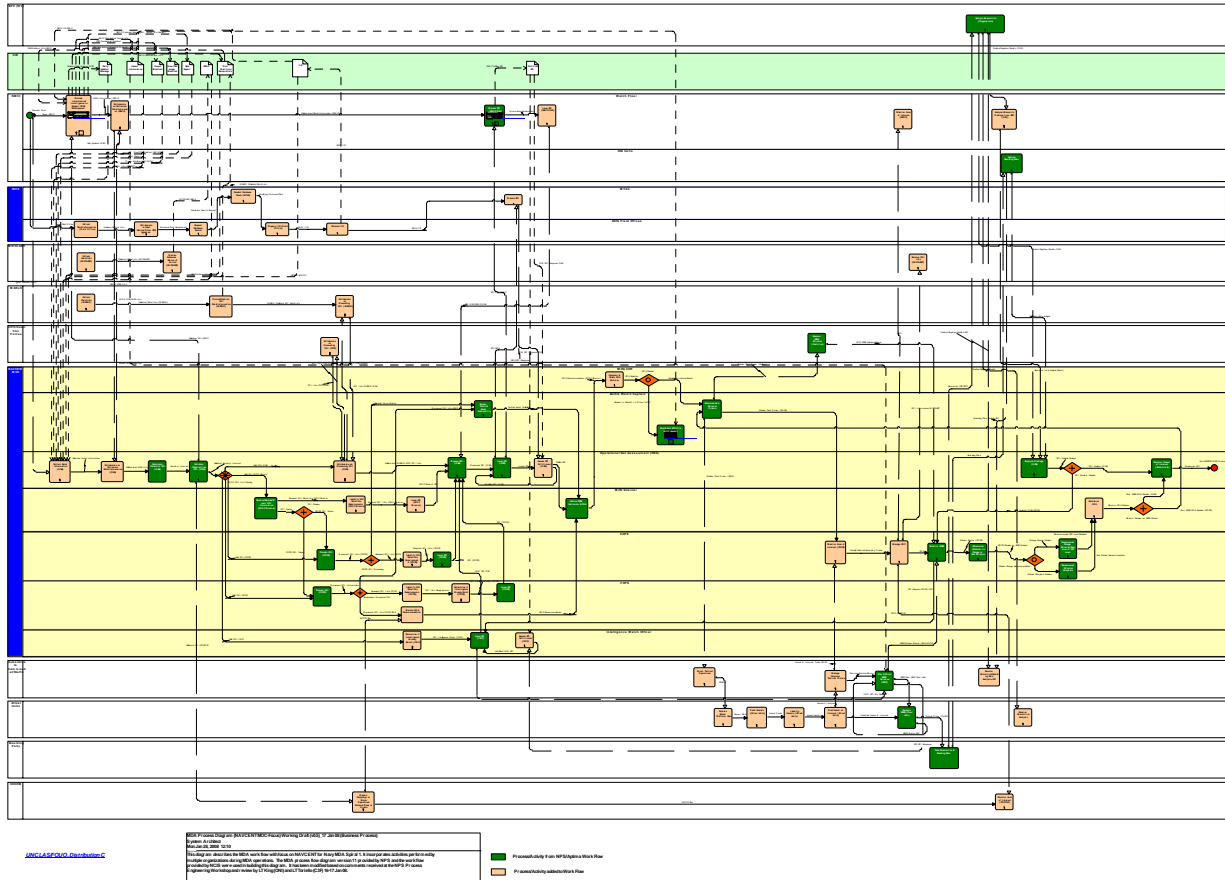

ONI Analyst

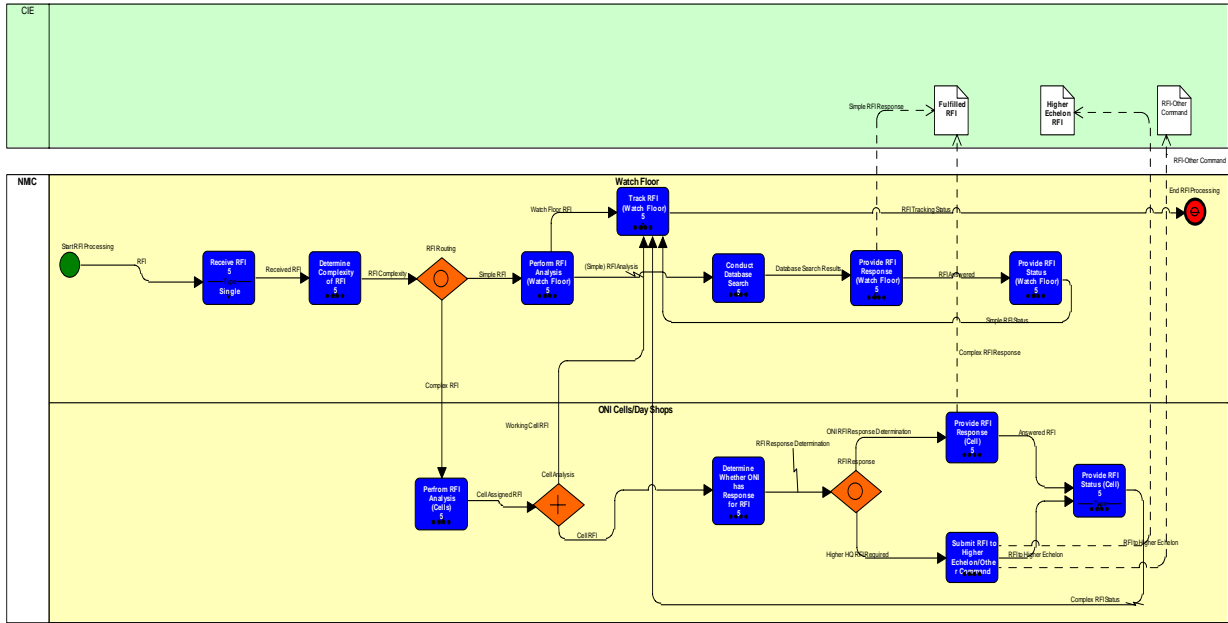

10. Process RFI (NMC/ONI), v0.2_17 Jan 08 (Business Process)
 System Architect
 Wed Jan 23, 2008 12:43
 Comments
 This diagram describes the draft ONI process for handling RFI as provided in notes form APTIMA based on discussions between Jared Freeman and ONI representatives Jim Stallings, LT Lange and Paul Carrall. It was also reviewed by ONI rep LT King at the Process Engineering Workshop on 17 JAN at NPS Monterey. No required changes were identified.

UNCLAS//FOUO Distribution C

THIS PAGE INTENTIONALLY LEFT BLANK

APPENDIX C. MATRIX INSIGHT

The workflow matrices were developed to illustrate the players and times used within the models and simulations. The ‘As-Is’ EMIO workflow matrix was developed from the current EMIO workflow, and the times and durations used were gathered from interviews and from LT Carroll’s 13 years in the Navy. The ‘Spiral-1’ EMIO workflow was developed from the current Spiral-1 efforts, and the times and durations were derived from interviews with Digital Force Technologies as the other times and durations remained the same as those processes were not changed. The ‘Optimal’ EMIO workflow was developed from academic theory and Spiral-1 efforts, and the times and durations were derived from interviews and experience. The times and durations used in the workflows are all approximate times and are not intended to be concrete, but instead to be as realistic as possible and to demonstrate how Spiral-1 technologies and changes in the workflow improve efficiency and effectiveness.

THIS PAGE INTENTIONALLY LEFT BLANK

LIST OF REFERENCES

- Bhatt, Ganesh D. 2000. *Exploring the relationship between information technology, infrastructure and business process re-engineering*. Business Process Management 6: 139-163.
- Davenport, Thomas. 1993. *Process innovation: Reengineering work through information technology*. Boston, Massachusetts: Harvard Business School Press.
- Davenport, Thomas, and James Short. 1990. *The new industrial engineering: Information technology and business process redesign*. MIT Sloan Management Review 31, (4).
- Donovan, John J. 1993. *Business re-engineering with technology*. An implementation guide. Cambridge, Mass: Cambridge Technology Group, Inc.
- El Sawy, Omar A. 2001. *Redesigning enterprise processes for e-business*. New York, NY: Irwin/McGraw-Hill.
- Freeman, Jared, Shelly Gallup, Douglas MacKinnon, and Susan Hutchins. 2008. Maritime domain awareness (MDA) workflow model status report.
- Freeman, Jared, and Susan Hutchins. October 2007. Memo to: MDA spiral 1 assessment group.
- Freeman, Jared, and Douglas MacKinnon. November 2007. Memo to: MDA spiral 1 assessment group.
- Galbraith, Jay R. 1974. Organization design: An information processing view. Interfaces 4.
- Grover, Varun, and Fiedler, Kirk D., Teng, James T.C. 1994. *Exploring the success of information technology "enabled business process reengineering"*. IEEE Transactions on Engineering Management 41.
- Hammer, Michael. 1996. *Beyond reengineering: How the process-centered organization is changing our work and our lives*. 1st ed. ed. New York, NY: HarperCollins.

- Hammer, Michael. 1990. *Reengineering work: Don't automate, obliterate*. Harvard Business Review 68, (4).
- Hammer, Michael, and James Champy. 1995. *Reengineering the corporation: A manifesto for business revolution*. Rev. paperback ed. London: Nicholas Brealey Publishing Limited.
- Incremental or Spiral Development of Evolutionary Acquisition. May 2008.
- Jin, Yan, and Raymond E. Levitt. 1996. *The virtual design team: A computational model of project organizations*. Department of Civil Engineering, Stanford University.
- Joint publication 1: Doctrine for the Armed Forces of the United States. May 2007.
- Leavitt, Harold J., ed. 1978. *Managerial psychology*. 4th ed. Chicago and London: The University of Chicago Press.
- Leavitt, Harold. 1965. *Applied organizational change in industry: Structural, technological and humanistic approaches*. In *Handbook of organizations*, ed. James G. March, 1144. Chicago: Rand McNally and Company.
- Leavitt, Harold. 1963. *The social science of organizations - four perspectives*. Prentice-Hall, Inc.
- Levitt, Raymond E., and John C. Kunz. 2002. *Design your project organization as engineers design bridges*.
- Maier, Mark. 2000. *The art of systems architecting*. 2nd ed. Boca Raton, Florida: CRC Press.
- Maritime Interdiction/Interception Operation Initial Capabilities Document (MIO ICD). Draft 1.0 ed. May 2007.
- Muthu, Subramanian, Larry Whitman, and S. Hossein Cheraghi. *Business process reengineering: A consolidated methodology*. Paper presented at Proceedings of The 4th Annual International Conference on Industrial Engineering Theory, Applications and Practice, San Antonio, Texas.
- National Concept of Operations for Maritime Domain Awareness. August 2007.

National Plan to Achieve Maritime Domain Awareness. October 2005.

National Security Presidential Directive NSPD-41. December 2004.

National Strategy for Maritime Security. September 2005.

Naval Coastal Warfare Initial Capability Document (NWC ICD). 10 August 2006. Draft 1.0 ed.

Naval Tactical Training Publication (NTTP) 3-07.11, ed. August 2003. *Maritime interception operations*. Change 1 Draft ed.

Naval Warfare Publication (NWP) 1-14M, ed. *The commander's handbook on the law of naval operations*.

Navy Maritime Domain Awareness Concept. May 2007.

O'Neill, Peter, and Amrik S. Sohal. 1999. *Business process reengineering "A review of recent literature"*. Technovation 19.

POW-ER Documentation for POW-ER 2.0. The Collaboratory for Research on Global Projects. <http://crgp.stanford.edu>, Accessed March 1996.

Ross, Jeanne W., Peter Weill, and David C. Robertson. 2006. *Enterprise architecture as strategy: Creating a foundation for business execution*. Boston, Massachusetts: Harvard Business School Press.

Scheer, August-Wilhelm. 1994. *Business process engineering: Reference models for industrial enterprises*. 2nd ed. ed. Heidelberg, Germany: Springer-Verlag.

Scoping Document for Navy Maritime Domain Awareness (MDA) Spiral 1 Prototype. Space and Naval Warfare Center. November 2007.

Scott Morton, Michael S., ed. 1991. *The corporation of the 1990s: Information technology and organizational transformation*. New York, NY: Oxford University Press.

Space and Naval Warfare MDA Prototype Working Group. 2007. White paper on MIO/EMIO requirements overview and vision as applied to SECNAV MDA prototype effort.

Tactical EMIO System. Digital Force Technologies Minutes of Meeting of Integration Design Review. 15 April 2008.

The New Industrial Engineering: *Information technology and business process redesign*. MIT Sloan Management Review 31, (4).

United States Fleet Forces Command. 2007. *The concept of operations for fleet maritime domain awareness*.

INITIAL DISTRIBUTION LIST

Defense Technical Information Center
Ft. Belvoir, Virginia

Dudley Knox Library
Naval Postgraduate School
Monterey, California

Secretary of the Navy
Department of the United States Navy
Washington, District of Columbia

OPNAV N3/N5
Office of the Chief of Naval Operations
Washington, District of Columbia

Naval Forces Central Command
Manama, Bahrain

Office Naval Intelligence
Washington, District of Columbia

SPAWAR O5
Space and Naval Warfare Systems Center
Charleston, North Carolina

Joint and National Systems Division Surveillance Systems
Space and Naval Warfare Systems Center
San Diego, California

Program Executive Officer Command, Control, Communications, Computers, and
Intelligence
Space and Naval Warfare Systems Center
Charleston, North Carolina

Dr. Dan C. Boger
Naval Postgraduate School
Monterey, California

Dr. Shelley. P. Gallup
Naval Postgraduate School
Monterey, California

Dr. Douglas MacKinnon
Naval Postgraduate School
Monterey, California