

LIMITATION OF GPS RECEIVER CALIBRATIONS

G. Paul Landis

**SFA, Inc./Naval Research Laboratory
4555 Overlook Ave., S.W.
Washington, D.C. 20375, USA
Tel: (202) 404-7061; Fax: (202) 767-2845
E-Mail: *landis@juno.nrl.navy.mil***

Joe White

**U.S. Naval Research Laboratory
Washington, D.C. 20375, USA
Tel: (202) 767-5111; Fax: (202) 767-4050
E-mail: *joe.white@nrl.navy.mil***

Abstract

The Naval Research Laboratory (NRL), as part of the Global Positioning System (GPS) Center of Expertise (COE) test program, performs absolute calibration of GPS receivers for time transfer. NRL did a simulation of this calibration method to verify the procedure. The simulation focused on the effects of filters, external to receiver, on receiver calibration. Two areas were investigated in this simulation. Will changes in the data from two different types of receivers track if the bandwidth of the signal source to both receivers change? If a filter is added between the antenna and a receiver, can this combination be calibrated in parts or must this combination be calibrated together?

CALIBRATION METHOD

The calibration of a GPS receiver is accomplished with a GPS signal simulator. The simulator generates two signals: a simulated GPS antenna signal and a one pulse per second reference [1]. The receiver is connected to the simulated antenna signal and the time determined by the receiver is compared with the time of the simulator reference (Figure 1). An additional step of calibrating the simulator is also necessary, which is done by connecting a high-speed digital scope to both outputs of the signal simulator. The pattern on the scope is shown in Figure 2. The calibration of the simulator is defined as the delay of the null in the envelope of the GPS signal for the one pulse per second reference. In some cases, an antenna system is placed between the simulator and receiver. The combination can be calibrated as a whole or in parts. If in parts, the delay of the antenna system is measured with a network analyzer. The absolute calibration of the receiver is defined as the delay of the receiver tick from the simulator tick less the simulator calibration and less the antenna system delay if the calibration is done in parts.

Report Documentation Page

Form Approved
OMB No. 0704-0188

Public reporting burden for the collection of information is estimated to average 1 hour per response, including the time for reviewing instructions, searching existing data sources, gathering and maintaining the data needed, and completing and reviewing the collection of information. Send comments regarding this burden estimate or any other aspect of this collection of information, including suggestions for reducing this burden, to Washington Headquarters Services, Directorate for Information Operations and Reports, 1215 Jefferson Davis Highway, Suite 1204, Arlington VA 22202-4302. Respondents should be aware that notwithstanding any other provision of law, no person shall be subject to a penalty for failing to comply with a collection of information if it does not display a currently valid OMB control number.

1. REPORT DATE DEC 2002		2. REPORT TYPE		3. DATES COVERED 00-00-2002 to 00-00-2002	
4. TITLE AND SUBTITLE Limitation of GPS Receiver Calibrations				5a. CONTRACT NUMBER	
				5b. GRANT NUMBER	
				5c. PROGRAM ELEMENT NUMBER	
6. AUTHOR(S)				5d. PROJECT NUMBER	
				5e. TASK NUMBER	
				5f. WORK UNIT NUMBER	
7. PERFORMING ORGANIZATION NAME(S) AND ADDRESS(ES) U.S. Naval Research Laboratory, 4555 Overlook Ave., S.W., Washington, DC, 20375				8. PERFORMING ORGANIZATION REPORT NUMBER	
9. SPONSORING/MONITORING AGENCY NAME(S) AND ADDRESS(ES)				10. SPONSOR/MONITOR'S ACRONYM(S)	
				11. SPONSOR/MONITOR'S REPORT NUMBER(S)	
12. DISTRIBUTION/AVAILABILITY STATEMENT Approved for public release; distribution unlimited					
13. SUPPLEMENTARY NOTES See also ADM001507. 34th Annual Precise Time and Time Interval (PTTI) Planning Meeting, 3-5 December 2002, Reston, VA					
14. ABSTRACT The Naval Research Laboratory (NRL), as part of the Global Positioning System (GPS) Center of Expertise (COE) test program, performs absolute calibration of GPS receivers for time transfer. NRL did a simulation of this calibration method to verify the procedure. The simulation focused on the effects of filters, external to receiver, on receiver calibration. Two areas were investigated in this simulation. Will changes in the data from two different types of receivers track if the bandwidth of the signal source to both receivers change? If a filter is added between the antenna and a receiver, can this combination be calibrated in parts or must this combination be calibrated together?					
15. SUBJECT TERMS					
16. SECURITY CLASSIFICATION OF:			17. LIMITATION OF ABSTRACT	18. NUMBER OF PAGES	19a. NAME OF RESPONSIBLE PERSON
a. REPORT unclassified	b. ABSTRACT unclassified	c. THIS PAGE unclassified			

BACKGROUND

A simple example will illustrate the concern NRL has about the calibration method. The example contains a single pole filter placed between a bi-phase modulator and a Delayed Locked Loop (DLL) receiver. The output of the single pole filter will have an exponential envelope after a bi-phase transition. The envelope will be of the form

$$\begin{aligned} \text{Envelope} &= 1, \text{ if } t < 0 \\ \text{Envelope} &= (2e^{-t/T_c} - 1), \text{ if } t > 0 \end{aligned}$$

where $t = 0$ at the time of the transition. The time constant, T_c , is equal to twice the reciprocal of the bandwidth of the filter in radians per second. The delay of the filter, as measured by the network analyzer, will be equal to the time constant. This transition, when viewed with the digital scope, will have an envelope null at $t = .6931T_c$.

The DLL will try to track this transition. A DLL has an early and a late correlator. The code reference to late correlator is delayed from the reference to the early correlator by a time called the correlator spacing. This is less than or equal to a code chip. The loop error signal is the difference in the output of the two correlators [2]. If the code reference to the correlators is not changing, the difference in the correlator outputs will be zero. The only time the loop error signal is nonzero is after a reference change for a period of time equal to the correlator spacing. The point where the DLL will track this transition can be found by finding where the cross-correlation of the envelope and the correlator spacing is zero. If this spacing is very small, the DLL will track the envelope null. Since the slope of the envelope is greater before the null than after the null, larger correlator spacing will cause the DLL to track after the null. The difference between the envelope null and the DLL tracking point is a function of the filter and the correlator spacing. With a single pole filter of bandwidth equal to twice the C/A code rate, the difference between the zero-crossing point and the one time constant point can be 47.7 ns.

The three measurements: the digital scope, the network analyzer and the DLL all give different results. Figure 3 shows a decay envelope, the one time constant point, and where the DLL would track if its correlator had a spacing of two time constants.

SIMULATION

The methods used in the above example will not support complex filters. A Fast Fourier Transform (FFT) method was selected for a simulation because it supports complex filters, transforms between time and frequency, and correlation. Figure 4 is a block diagram of the processing in the simulation. FFT end effects are avoided by requiring the number of points in a chip and the number of chips both to be a power of two [3]. With GPS, the carrier frequency is an integer multiple of the code frequency, which guarantees an integer number of carrier cycles in the FFT data.

RESULTS

The simulation had different filters in three areas: the receiver, the antenna, and the RF source. Each area has three identical filters. Three different bandwidths were used for each area. Five different values of correlator spacing were used as a fourth variable to cover both C/A and P/Y. All combinations of the four variables produced a total of 135 simulations.

Table 1 shows the selection of variables used and receiver calibrations of the simulation runs. Figure 5 shows how well different receivers track with changes in simulator filters. Figure 6 shows how dependent receiver calibration is on antenna filters.

CONCLUSIONS

The conclusions are based on the results of the 135 simulations. Changes in the bandwidth of the RF source will track to within less than 2 ns. Calibration of the receiver in parts can lead to errors of 6 ns. These are extreme condition and in most cases they would not be encountered.

Since the bandwidth of the RF source is typically greater than the antenna system, which is typically greater than the receiver bandwidth, information on the receiver filters is the most critical in this analysis. Bandwidths external to the receiver become more significant as they approach the receiver bandwidth. Accurate calibration of receivers with wide bandwidths and narrow correlators is more dependent on knowledge of the hardware than receivers with wide correlators and narrow bandwidths.

To accurately calibrate a receiver for time transfer, the hardware filters could be measured on the network analyzer and this information along with correlator spacing could be used in the simulation. The results of the simulation then could be used to modify the receiver calibration. An estimate of the filters could be used to reduce the calibration errors if it is not practical to measure the filters. With knowledge of the hardware, the limiting factor of the receiver calibration method is the calibration of the GPS signal simulator at the nanosecond level [1].

REFERENCES

- [1] J. White, et al., 2001, “*Dual Frequency Absolute Calibration of a GPS Receiver for Time Transfer,*” in Proceedings of the 15th European Frequency and Time Forum (EFTF), 6-8 March 2001, Neuchâtel, Switzerland (Swiss Foundation for Research in Microtechnology, Neuchâtel), pp. 167-170.
- [2] R. C. Dixon, 1976, **Spread Spectrum Systems** (John Wiley & Sons, New York), pp. 210-212.
- [3] E. O. Brigham, 1974, **The Fast Fourier Transform** (Prentice-Hall, Inc., Englewood Cliffs, New Jersey), 115 pp.

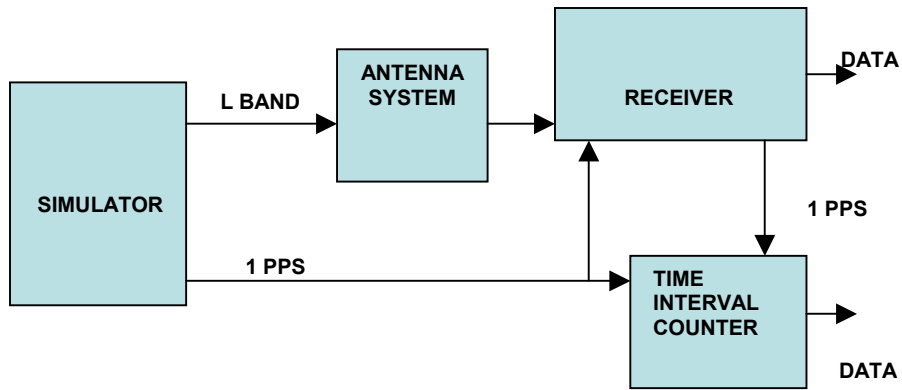

Figure 1. Block diagram of receiver calibration method.

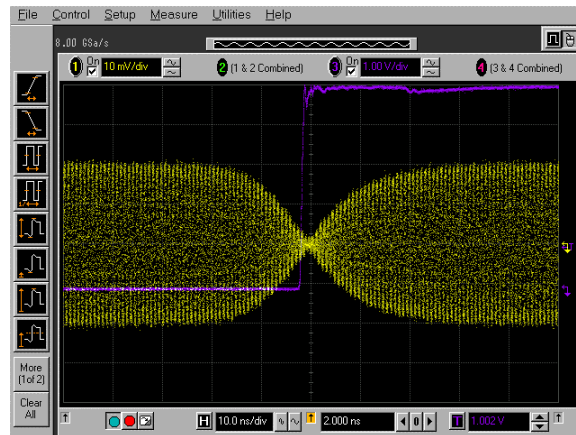

Figure 2. Zero crossing of single PRN L band simulator signal seen on a digital scope.

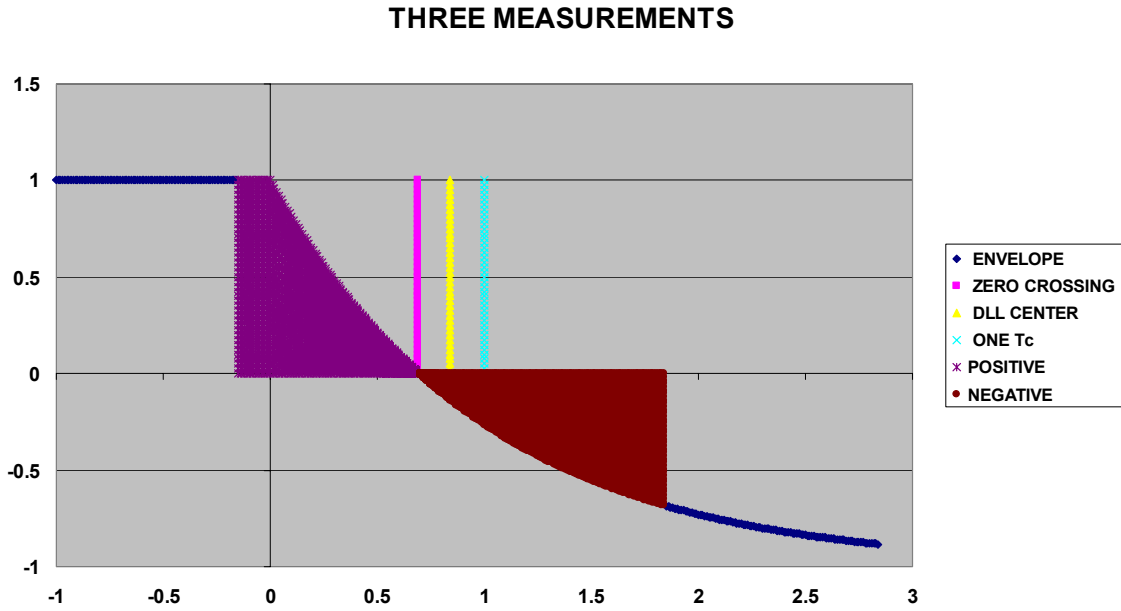

Figure 3. Single pole filter envelope and relative position of three measurements.

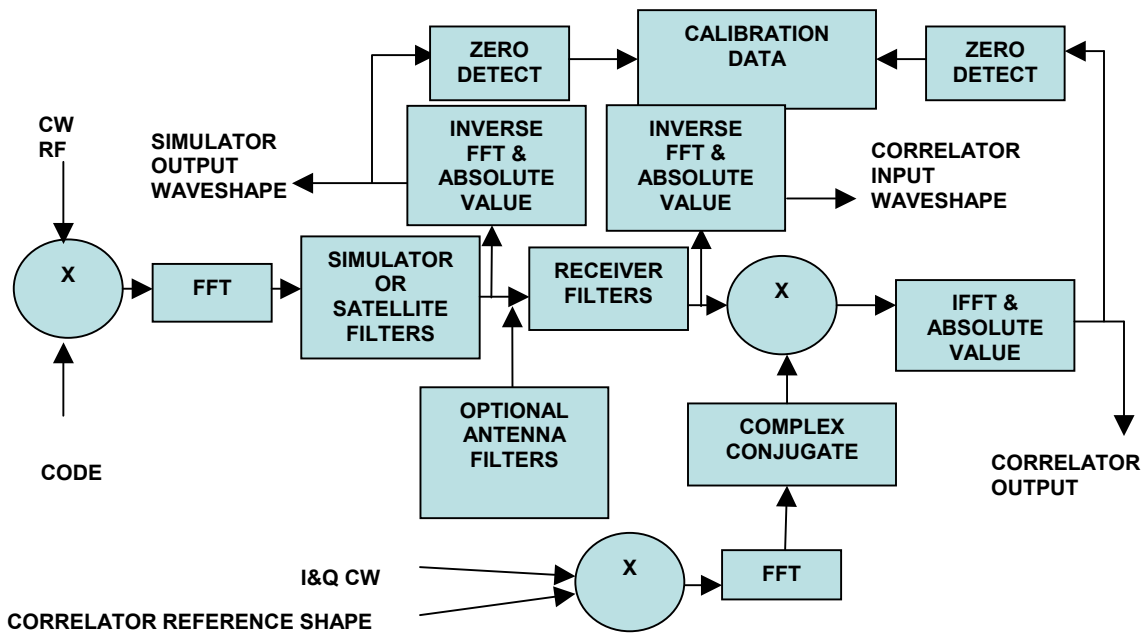

Figure 4. Block diagram of simulation processing.

TIMING CHANGES WITH RF SOURCE BANDWIDTH CHANGE

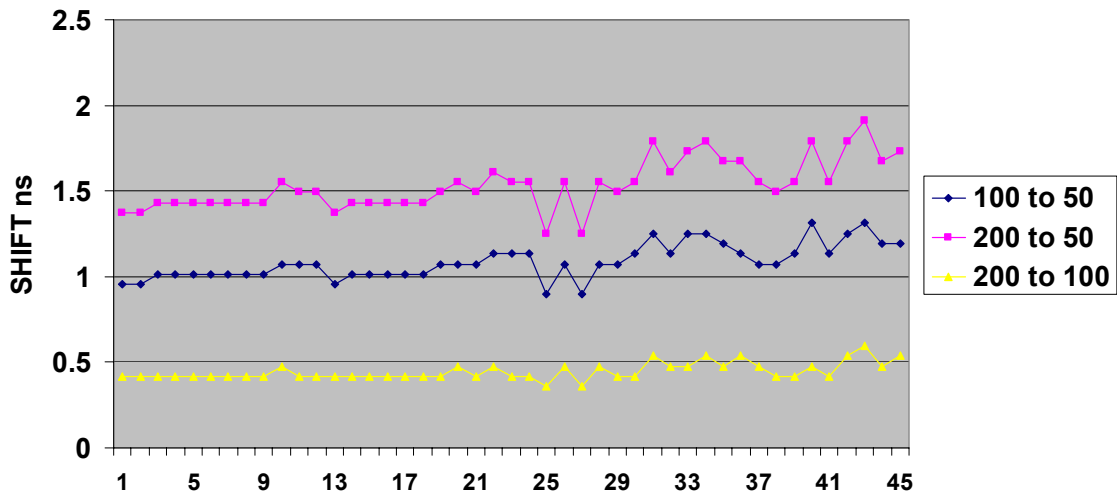

Figure 5. Changes in receiver calibration with changes in source bandwidth.

TIMING CHANGES WITH ANTENNA BANDWIDTH CHANGE

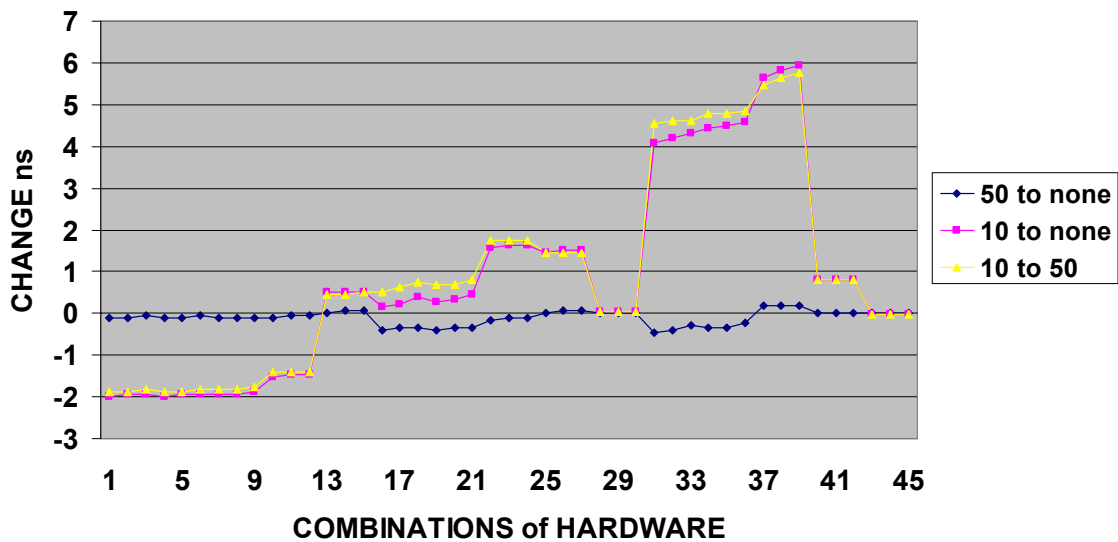

Figure 6. Changes in receiver calibration with changes in antenna bandwidth.

Table 1. Simulation bandwidths and results.

Receiver Calibration ns										
Antenna		10	10	10	50	50	50	∞	∞	∞
BW MHz		50	100	200	50	100	200	50	100	200
Receiver	Receiver									
BW MHz	Spacing ns									
2	977	465.76	464.80	464.38	466.26	465.24	464.83	466.27	465.31	464.89
2	313	435.33	434.25	433.84	433.92	432.85	432.43	433.87	432.79	432.32
2	97.7	430.20	429.12	428.65	428.37	427.30	426.88	428.26	427.19	426.77
2	31.3	429.66	428.59	428.17	427.84	426.70	426.28	427.72	426.65	426.17
2	9.7	429.60	428.53	428.11	427.78	426.64	426.23	427.66	426.59	426.1
10	977	97.46	96.44	96.02	97.48	96.47	96.05	97.49	96.47	96.06
10	313	95.37	94.35	93.94	96.83	95.81	95.39	96.83	95.88	95.46
10	97.7	88.51	87.37	86.96	90.26	89.13	88.71	90.15	89.02	88.54
10	31.3	87.31	86.18	85.70	88.12	86.86	86.39	87.76	86.51	85.97
10	9.7	87.14	86.00	85.58	87.88	86.62	86.09	87.53	86.21	85.74
20	977	49.73	48.71	48.29	49.69	48.68	48.26	49.70	48.68	48.27
20	313	48.89	47.88	47.46	49.69	48.68	48.26	49.70	48.68	48.27
20	97.7	42.57	41.49	41.02	48.02	47.13	46.77	48.21	47.31	46.95
20	31.3	40.96	39.76	39.29	45.75	44.62	44.08	45.52	44.27	43.73
20	9.7	40.78	39.58	39.11	45.40	44.20	43.67	45.11	43.79	43.12

QUESTIONS AND ANSWERS

DEMETRIOS MATSAKIS (U.S. Naval Observatory): Those are pretty large changes in the receivers and transmitter systems. If you had milder changes such as you might get with a temperature variation, calibrating at one temperature, and then installing at another, would you expect it to be a lot less numerically?

PAUL LANDIS: Yes.

DAVE HOWE (National Institute of Standards and Technology): Can you comment about what kind of temperature stability you might need for the filter, for example? Because this also has relevance to two-way.

LANDIS: I do not have a good feel for how filters change with temperature.