

HT2007-321962

ELECTRONICS THERMAL MANAGEMENT USING ADVANCED HYBRID TWO-PHASE LOOP TECHNOLOGY

Chanwoo Park¹, Aparna Vallury², Jon Zuo³, Jeffrey Perez⁴ and Paul Rogers⁵

^{1,2,3}*Advanced Cooling Technologies, Inc. Lancaster, PA 17601, USA*

^{4,5}*U.S. Army TACOM, Warren, MI 48397, USA*

¹*Tel: 717-295-6073, e-mail: chanwoo.park@1-act.com*

ABSTRACT

The paper discusses an advanced Hybrid Two-Phase Loop (HTPL) technology for electronics thermal management. The HTPL combined active mechanical pumping with passive capillary pumping realizing a reliable yet high performance cooling system. The evaporator developed for the HTPL used 3-dimensional metallic wick structures to enhance boiling heat transfer by passive capillary separation of liquid and vapor phases. Through the testing using various prototype hybrid loops, it was demonstrated that the hybrid loops were capable of removing high heat fluxes from multiple heat sources with large surface areas up to 135cm² and 10kW heat load. Because of the passive capillary phase separation, the hybrid loop operation didn't require any active flow control of the liquid in the evaporator, even at highly transient and asymmetrical heat inputs between the evaporators. These results represent the significant advance over state-of-the-art heat pipes, loop heat pipes and evaporative spray cooling devices in terms of performance, robustness and simplicity.

INTRODUCTION

The two-phase cooling technologies used for aerospace applications include heat pipes, loop heat pipes (LHP) and capillary pumped loops (CPL) which are all passive thus very reliable devices relying on only capillary pumping. However, the passive devices could not meet future challenging cooling demand because of the inherent limitation of the capillary pumping in terms of heat flux, transport distance and multiple heat source capabilities [Kuszewski and Zerby, 2002; Ponnappan, et al., 2002].

Recently, the pump-assisted, two-phase cooling designs using micro-channel and spray have been developed for high

heat flux cooling systems [Kawaji and Chung, 2003; Estes and Mudawar, 1995]. The successful integration of mechanical pumps into the heat rejection system of the NASA's Mars Exploration Rover also helped set the current technical trend of the increasing use of the active cooling design for space applications [Birur, 2006; Swanson, 2006]. However, the potential reliability issues due to large pumping pressure, flow instability (for micro-channel design), complex fluid reconditioning and nozzle clogging/erosion (for spray design) significantly reduce the merit of the active designs. In the past years, the pump-assisted and capillary (or hybrid) two-phase loop technologies have been developed to overcome such shortcomings of the aforementioned active two-phase designs [Ambrose et al., 1992; Masao, 2003; U.S. NRL 2005; Park et al., 2007a, 2007b, 2006, 2005a, 2005b, 2005c, 2004, Zuo et al., 2004].

HYBRID TWO-PHASE LOOP TECHNOLOGY

This paper presents an advanced Hybrid Two-Phase Loop (HTPL) technology which integrated active mechanical pumping with passive capillary pumping for electronics thermal management. The simplest HTPL configuration consists of an evaporator, a liquid-cooled condenser, a liquid reservoir and a mechanical gear pump as illustrated in Figure 1. The evaporator used for the HTPL has three fluid connections for a liquid inlet, an excess liquid outlet and a vapor outlet. The internal capillary structure of the evaporator was made of a sintered copper and screen composite structure. The 3-dimensional capillary structure can effectively distribute the liquid over the large area of the evaporator while separating vapor from liquid thus promoting optimum thin film boiling regardless of varying heat inputs. The evaporator

Report Documentation Page

Form Approved
OMB No. 0704-0188

Public reporting burden for the collection of information is estimated to average 1 hour per response, including the time for reviewing instructions, searching existing data sources, gathering and maintaining the data needed, and completing and reviewing the collection of information. Send comments regarding this burden estimate or any other aspect of this collection of information, including suggestions for reducing this burden, to Washington Headquarters Services, Directorate for Information Operations and Reports, 1215 Jefferson Davis Highway, Suite 1204, Arlington VA 22202-4302. Respondents should be aware that notwithstanding any other provision of law, no person shall be subject to a penalty for failing to comply with a collection of information if it does not display a currently valid OMB control number.

1. REPORT DATE 8 JUL 2007		2. REPORT TYPE N/A		3. DATES COVERED	
4. TITLE AND SUBTITLE Electronics Thermal Management Using Advanced Hybrid Two-Phase Loop Technology				5a. CONTRACT NUMBER	
				5b. GRANT NUMBER	
				5c. PROGRAM ELEMENT NUMBER	
6. AUTHOR(S) ;; ; Park /ChanwooVallury /AparnaZuo /JonPerez /JeffreyRogers /Paul				5d. PROJECT NUMBER	
				5e. TASK NUMBER	
				5f. WORK UNIT NUMBER	
7. PERFORMING ORGANIZATION NAME(S) AND ADDRESS(ES) US Army RDECOM-TARDEC 6501 E 11 Mile Rd Warren, MI 48397-5000				8. PERFORMING ORGANIZATION REPORT NUMBER 17112	
9. SPONSORING/MONITORING AGENCY NAME(S) AND ADDRESS(ES) TARDEC				10. SPONSOR/MONITOR'S ACRONYM(S)	
				11. SPONSOR/MONITOR'S REPORT NUMBER(S)	
12. DISTRIBUTION/AVAILABILITY STATEMENT Approved for public release, distribution unlimited.					
13. SUPPLEMENTARY NOTES					
14. ABSTRACT					
15. SUBJECT TERMS					
16. SECURITY CLASSIFICATION OF:			17. LIMITATION OF ABSTRACT SAR	18. NUMBER OF PAGES 6	19a. NAME OF RESPONSIBLE PERSON
a. REPORT unclassified	b. ABSTRACT unclassified	c. THIS PAGE unclassified			

has a planar form factor which is the most desirable for typical electronics cooling.

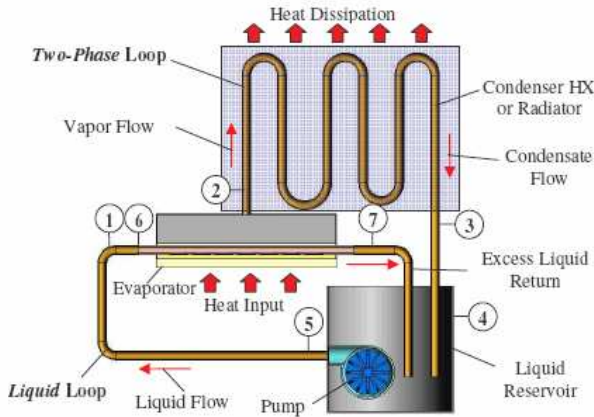

Figure 1 Schematic of hybrid two-phase loop.

Because of the use of active pumping, the hybrid loop can manage multiple evaporators in various configurations (either parallel or series) over long transport lines. The typical pressure profile of the HTPL is shown in Figure 2 for explanation purpose. The fluid nodes used of the HTPL is also shown in both Figures 1 and 2. The mechanical pump feeds liquid from the liquid reservoir to the evaporator, then, the passive capillary action inside the evaporator wick draws the liquid to the vapor volume of the evaporator. The liquid inlet (nodes 1 or 6) has a lower pressure than the vapor volume (node 2) of the evaporator because of the capillary pumping in the evaporator wick. The passive capillarity always assures the thin film boiling in the wick of the evaporator and the pressure balance between the vapor and liquid zones.

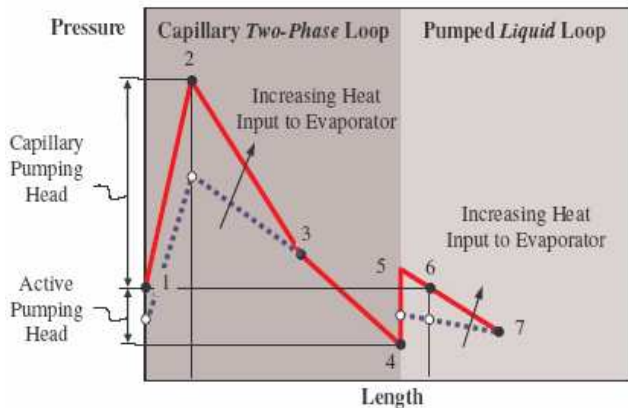

Figure 2 Pressure profile of hybrid two-phase loop.

As the heat input increases, the system temperature and pressure increase. In addition, the liquid temperature of the reservoir which is determined by the energy balance by both the heated excess liquid return and the subcooled condensate return, governs the operating temperature of the HTPL. The

vapor generated from the evaporator is fed into the condenser and then to the reservoir through the two-phase loop. The excess liquid returns to the liquid reservoir through the separated liquid loop. Even though the overall system pressure drop is extended by the active pumping beyond the capillary pumping limit, the maximum heat flux capability of the evaporator will still be limited by the wicking capability of the capillary structure of the evaporator.

SINGLE EVAPORATOR HYBRID TWO-PHASE LOOP

The schematic of the hybrid cooling loop with single evaporator is shown in Figure 3. For better understanding on the hybrid loop operation, a single evaporator system was built and tested before building multiple-evaporator systems. The evaporator was made of copper and has the effective planar heat source area of 135cm². The evaporator had three fluid lines for liquid supply, excess liquid return and vapor exit. De-ionized water was used as a working fluid for the hybrid loop.

The instrumentation used to monitor the hybrid loop operation included pressure transducers, turbine flow meters and thermocouples. The heat input into the evaporator was measured by a wattmeter. As further verification, the calorimetry was performed for both the condenser and the reservoir. Prior to charging fluid, the entire system was checked for any leaks using a helium mass-spectrometer leak checker.

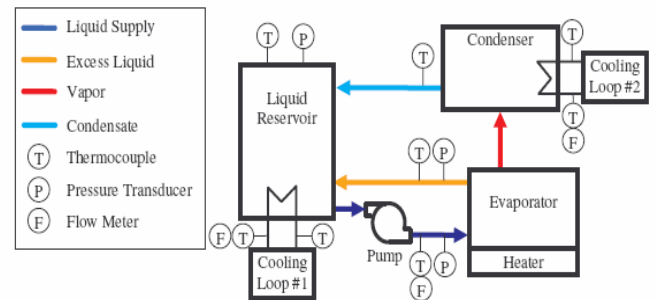

Figure 3 Schematic of hybrid two-phase loop with single evaporator.

The test started by turning on the liquid pump to circulate the liquid throughout the loop. Once the pump speed was adjusted to feed a certain liquid flow, the pump speed was kept the same during the testing. The flow rate used for the testing was about 0.3 liter/min. Three joule-heating cartridge heaters in the integrated heater block with the evaporator were used to provide the heat input, according to the pre-set power cycles in which the heat input was incrementally increased from zero to a maximum and then decreased to zero. The maximum heat load of 4.0kW or the heat fluxes of 30W/cm² used for the testing. At each power step, the system was allowed to reach steady-state conditions.

Figure 4 shows the temperature and thermal resistance profiles of the hybrid loop under a power cycle. At the maximum heat load of 4.0kW, the evaporator body temperature reached to approximately 60°C. The liquid supplied to the evaporator was slightly higher than the temperature of the condensate return at 18°C. The subcooling at the condenser compensated the parasitic heat leak by the excess liquid return.

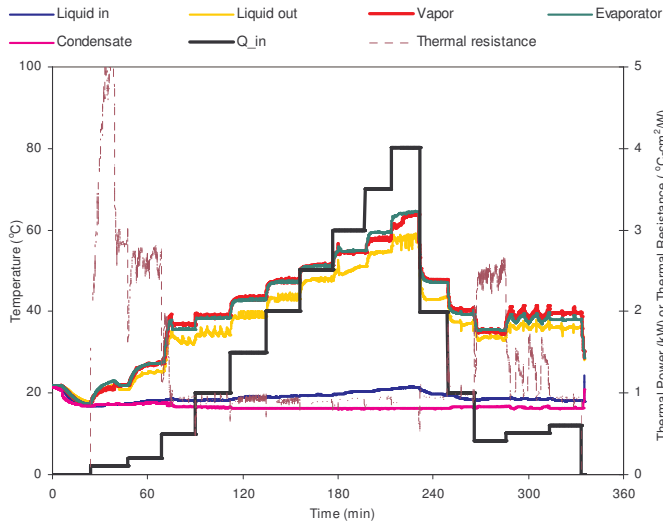

Figure 4 Temperature and evaporator thermal resistance variations of hybrid two-phase loop.

Figure 4 also shows the evaporator thermal resistance. The thermal resistance was defined between the vapor and evaporator wick surface temperatures. The evaporator thermal resistance varied between 0.83 and 0.92°C-cm²/W. Such low thermal resistance was attributed to the thin film boiling of the subcooled liquid.

Note that at the heat input range of 100W ~ 500W, the thermal resistance highly fluctuates. This fluctuation resulted from unstable pool boiling of the pre-occupying liquid in the vapor volume at low heat inputs. The phenomenon is called “cold start”. The fact can be reconfirmed by the reduction of such fluctuation during the power ramp-down when the vapor already displaced the liquid. When the heat load was increased again from 400W to 600W, the unstable fluctuating thermal resistance was observed again but in lessened magnitude. The smooth cold start could be attributed to the residual heat stored in the HTPL which helped initiate boiling easily. The minimum heat input for the two-phase cooling (or boiling) onset in the HTPL was measured to be around 500W (or 3.7W/cm²) as shown in Figure 4.

The heat input was gradually increased up to 4.0kW (or 30W/cm²) while keeping the pumping speed the same. The maximum heat input was limited by the capacity of the heaters used for the test setup. Considering the evaporator temperature around 60°C even at the maximum heat

condition, much higher heat flux over 50W/cm² could be possible for electronics cooling applications.

The pressure measurement result is shown in Figure 5. The liquid pressure was averaged between the inlet (at liquid supply) and outlet (at excess liquid) of the liquid line for the evaporator. The vapor pressure was always higher than the liquid pressure in the evaporator by about 1”Hg, which is a preferred condition for the system to operate using the capillary pumping.

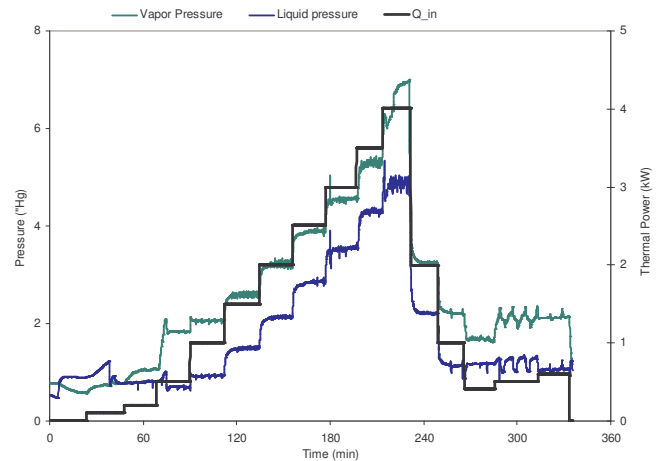

Figure 5 Pressure variations of HTPL.

The calorimetry measurement as shown in Figure 6 indicates some discrepancy in the system energy balance which could be attributed to the measurement error and heat gain from ambient. The heat leak through the excess liquid return was measured to be about 11% at the maximum heat input of 4.0kW. The heat leak remained rather relatively steady over various heat input conditions.

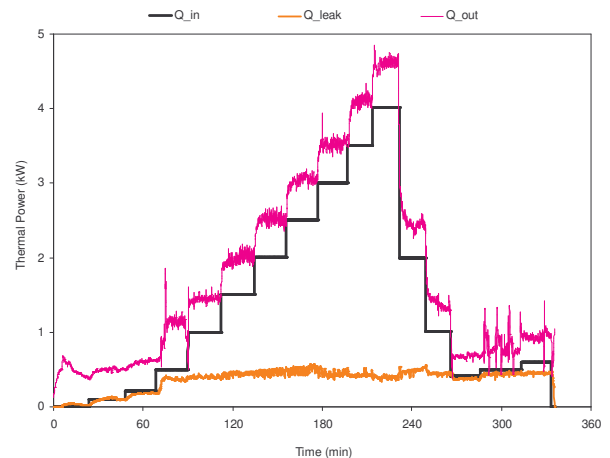

Figure 6 Calorimetry of hybrid two-phase loop.

MULTIPLE EVAPORATOR HYBRID TWO-PHASE LOOP

The HTPL as shown in Figure 7 consists of four evaporators in parallel, a gear pump, a liquid-cooled condenser. The HTPL was constructed of mostly copper except for the liquid reservoir and condenser made of stainless steel. The electric cartridge heaters were used as the heat source for the evaporators. The HTPL used various structural brackets which were necessary for Mil-Spec vibration/shock testing planned as future task. Meanwhile, the non-operational survivability test using the same evaporator used in the HTPL was performed using the Mil-Spec vibration/shock conditions for Army vehicles. After the vibration and shock testing, the evaporator was successfully tested without any degradation in performance.

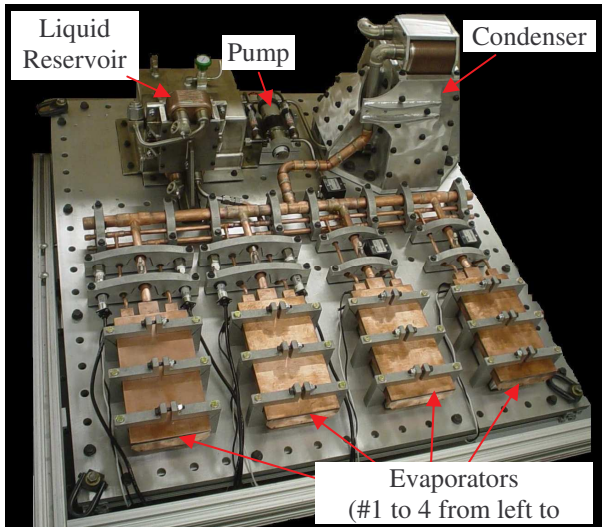

Figure 7 Four-evaporator hybrid two-phase loop.

The operation of the multiple evaporator HTPL started first by turning on the liquid pump and then the evaporator heaters while the condenser and auxiliary heat exchanger are running. During the test, the pump speed was kept the same regardless of the heat inputs.

Figures 8 through 11 show the test results for a symmetric heat load case with the maximum heat input of 2,500 watts per each evaporator. The temperature and thermal resistance profiles of the evaporators #1 and #3 are shown in Figures 8 and 9 respectively. All four evaporator temperatures responded similarly in trend. The difference between the temperatures was caused mainly by the uneven flow and pressure distribution between the evaporators, not to mention the different performance of each evaporator due to manufacturing inconsistency. The cold start of the high thermal resistance due to the liquid flooding in the evaporators was observed for all four evaporators.

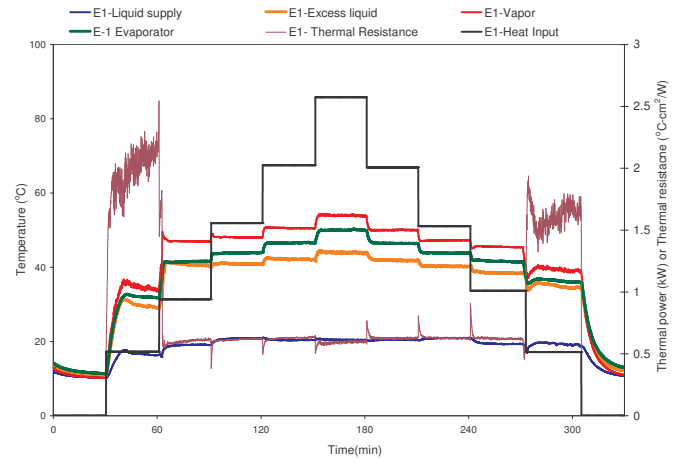

Figure 8 Temperature and thermal resistance variations of Evaporator #1.

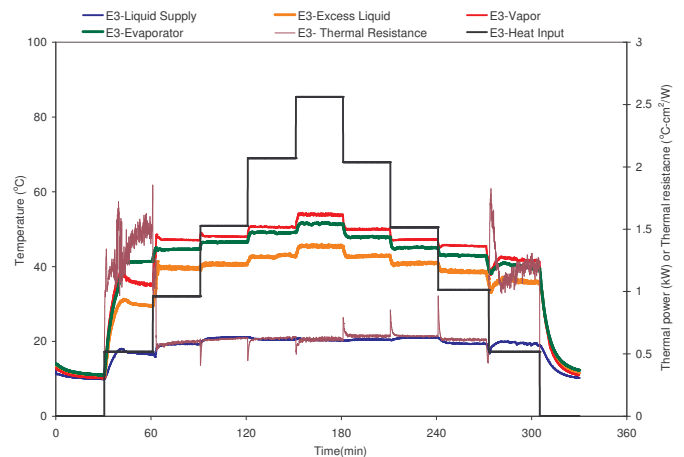

Figure 9 Temperature and thermal resistance variations of Evaporator #3.

Figure 10 shows the vapor pressure of the evaporator #1 which was higher than the liquid pressure by about 1” Hg. It indicates the capillary pumping of the evaporator wick in action to feed the liquid in perfect balance to the heat input. The total water flow rate from the pump was measured to be about 1.2 liter/min over the power cycle. The pump power consumption was measured to be less than 4 Watts. The cooling efficiency of the HTPL which was defined to the ratio of the heat rejection to the pump power is about 2,500.

The system calorimetry was well balanced as shown in Figure 11. The heat leak by the excess liquid return was measured to be about 5% (or 500W) at the maximum heat load and slightly varied according to the heat input. The excess liquid was cooled by an auxiliary heat exchanger before returning to the reservoir. Finally, the subcooled condensate will compensate the heat leak by the excess liquid return in the reservoir.

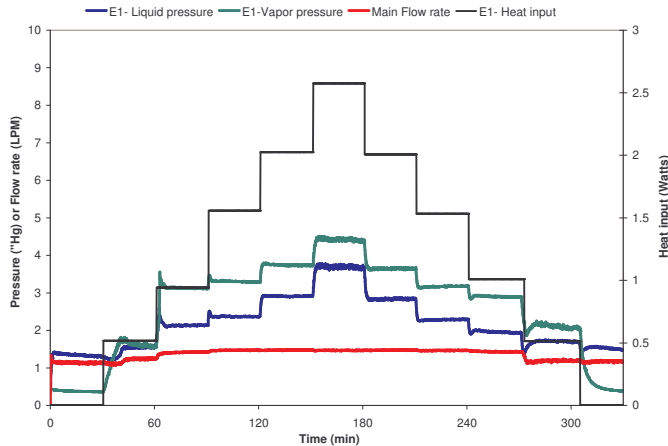

Figure 10 Pressure and flow rate variations in Evaporator #1.

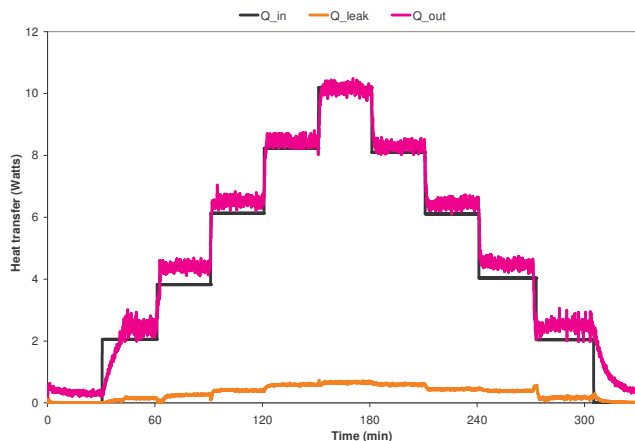

Figure 11 Calorimetry of four-evaporator hybrid two-phase loop.

CONCLUSIONS

Advanced Hybrid Two-Phase Loop (HTPL) technology was demonstrated using prototype hybrid loops with up to four evaporators. The power cycle testing revealed that the HTPL was capable of managing multiple heat sources with the effective heat source area of 135cm^2 ($=7.6\text{cm}\times 17.8\text{cm}$) and the total heat inputs up to 10kW . The heat load capability was solely limited by the capacity of the heaters used for the testing. The measured evaporator thermal resistance was as low as $0.6^\circ\text{C}\text{-cm}^2/\text{W}$ and remained relatively constant regardless of varying heat loads after the cold start condition at the heat load around 500W (or $3.7\text{W}/\text{cm}^2$).

The major achievements from this work are summarized as follows.

- **High Heat Flux and Large Heat Load Capability:** The hybrid two-phase loop managed the large heat load up to 10kW and high heat flux up to $30\text{W}/\text{cm}^2$. The much higher heat flux ($>50\text{W}/\text{cm}^2$) could be achieved considering the low evaporator temperature of 60°C .

- **Large Heat Source Cooling Capability:** The evaporator with a large planar surface area of 135cm^2 effectively performed passive capillary liquid distribution and vapor/liquid phase separation. The planar evaporator design is easily scalable to the high performance cooling applications requiring large area, high heat flux and various form factor heat sources.
- **Multiple-Evaporator Operation:** The hybrid two-phase loop demonstrated multiple evaporator capability using four evaporators at symmetric/asymmetric power cycles.
- **Robust Operation and Simple Design:** The hybrid two-phase loop demonstrated the superior two-phase cooling performance with low thermal resistances requiring no active flow control. The robust operation using simple design of the hybrid two-phase loop promises very reliable and compact cooling systems providing great design flexibility and excellent performance for various electronics cooling applications.

ACKNOWLEDGMENTS

This work was performed under Army SBIR Phase II Contract No. W56HZV-04-C-0704. The authors wish to acknowledge the contributions of Mr. Jeff Reichl at ACT for his efforts in fabrication of the hybrid loop hardware.

REFERENCES

- Kuszewski, M. and Zerby, M., "Next generation Navy thermal management program", CARDIVNSWC-TR-82-2002/12, 2002.
- Ponnappan, R., Donovan, B. and Chow, L., "High power thermal management issues in space-based systems", Space Technology and Applications International Forum-STAIF 2002, Albuquerque, New Mexico, February 3~6, 2002.
- Kawaji, M. and Chung, P.M.-Y., "Unique characteristics of adiabatic gas-liquid flows in microchannels: Diameter and shape effects on flow patterns, void fraction and pressure drop", Proceedings of 1st International Conference on Microchannels and Minichannels, Rochester, New York, April 24~25, 2003.
- Estes, K. and Mudawar, I., "Comparison of Two-Phase Electronic Cooling Using Free Jets and Sprays", Journal of Electronic Packaging, 1995, Vol.117, pp.323-332.
- Gaj Birur, "JPL Advanced Thermal Control Technology Roadmap-2006", 17th Aerospace Spacecraft Thermal Control Workshop, El Segundo, California, March 14~16, 2006.
- Ted Swanson and Dan Butler, "NASA/Goddard Thermal Control Technology Roadmap-2006", 17th Aerospace Spacecraft Thermal Control Workshop, El Segundo, California, March 14~16, 2006.
- Ambrose, J. H., Tung, J. H., Field, A. R. and Holmes, H. R., "Two-Phase Survivable Thermal Management – Heat Acquisition and transport Components", 1992 SAE Aerospace Atlantic Conference, Dayton, Ohio, April 7~10, 1992.

Masao Furukawa, “Multi-Purpose Mechanical/Capillary Hybrid Pump Loop”, 33rd International Conference on Environmental Systems (ICES), Vancouver, British Columbia, Canada, SAE 2003-01-2388, 2003.

U.S. Naval Research Laboratory, “Evaluation of a Magnetically-Driven Bearingless Pump for Space Applications”, 2005 International Two-Phase Thermal Control Technology Workshop, Los Angeles, California, March 7~8, 2005.

Chanwoo Park, Aparna Vallury, Jon Zuo, Jeffrey Perez and Paul Rogers, “Spacecraft Thermal Management using Advanced Hybrid Two-Phase Loop Technology”, 2007 in the proceedings of *Space Technology and Applications International Forum* (STAIF 2007), edited by M.S. El-Genk, AIP Conf. proceedings 608, Melville, NY, 2007a, pp. 65-72.

Chanwoo Park, “Spacecraft Thermal Management using Advanced Hybrid Two-Phase Loop Technology”, 2007 Spacecraft Thermal Control Workshop, Los Angeles, California, February 27~ March 1, 2007b.

Chanwoo Park, Aparna Vallury and Jeffrey Perez, “Advanced hybrid cooling loop technology for high performance thermal management”, 4th International Energy Conversion Engineering Conference, San Diego, California, AIAA 2006-4059, 2006.

Chanwoo Park, Jon Zuo and Jeffrey Perez, “Advanced Hybrid Loop Technology for High Heat Flux Laser Cooling”, 3rd International Energy Conversion Engineering Conference, San Francisco, California, AIAA 2005-5696, 2005a.

Chanwoo Park, David Sarraf and Jon Zuo, “Hybrid Loop Cooling of High Heat Flux Components”, 2005 International Two-Phase Thermal Control Technology Workshop, Los Angeles, California, March 7~8, 2005b.

Park C., Zuo, Z. J., Rogers P. and Perez J., “Two-Phase Flow Cooling for Vehicle Thermal Management”, SAE-2005-01-1769, 2005c.

Jon Zuo, Chanwoo Park and Dave Sarraf, “Hybrid Loop Cooling of High Heat Flux Components”, 2nd International Energy Conversion Engineering Conference, Providence, Rhode Island, AIAA 2004-5612, 2004.

Park C., Zuo, Z. J., Rogers P. and Perez J., “Hybrid Loop Thermal Bus Technology for Vehicle Thermal Management”, 24th Army Science Conference, Orlando, Florida, November, 2004.