

# ANALYSIS OF ONE YEAR OF ZERO-BASELINE GPS COMMON-VIEW TIME TRANSFER AND DIRECT MEASUREMENT USING TWO CO-LOCATED CLOCKS

Gerrit de Jong and Erik Kroon  
NMI Van Swinden Laboratorium  
P.O. Box 654, 2600 AR Delft, the Netherlands

## Abstract

*As part of the Galileo project of Early Trials on Time Synchronization Techniques and Calibration Issues, the (near) zero-baseline GPS Common-View Time Transfer and Direct Measurement (using a Time Interval Counter) results between the time scales of two co-located clocks during 2001 were analyzed. This was done to identify the obtainable uncertainty levels with these techniques. The result of the analysis is presented. The baseline of the antennas of the two single-channel NBS-type GPS C-V receivers was 2 m, so multi-path influence is not excluded. The uncertainties from statistical origin (Type A evaluation) were determined by means of MDEV and TDEV. The uncertainties from other sources (Type B evaluation) were determined from calibrations. The TDEV of the GPS C-V result was less than 0.4 ns at averaging times > 1 day, and at shorter averaging times TDEV was about 1 ns.*

## 1 INTRODUCTION

The work described in this paper was done in the framework of the Galileo project as part of an ESA Early Trials study on Time Synchronization Techniques and Calibration Issues. The goal was to verify the 1 ns GPS Common-View (C-V) clock synchronization accuracy assumption in a laboratory (“best case”) co-located clock comparison experiment.

For this purpose during 2001 a laboratory test has been performed at VSL to compare the time scales from two co-located cesium clocks by direct measurement using a time interval counter (TIC) and by means of two co-located (near zero baseline) GPS C-V receivers. The latter is the “best case” situation of GPS C-V, because the high correlation, and hence first-order cancellation, for environmental effects such as temperature, humidity, troposphere, ionosphere, rainfall, etc. The difference of the results of the two methods is given and discussed.

## 2 GENERAL

### 2.1 CLOCKS AND TIME SCALES USED

NMI-VSL uses a commercial high-performance cesium clock (HP5171A) followed by a phase micro-stepper for UTC (VSL), which serves as the direct reference for the first GPS receiver (VSL01). A

# Report Documentation Page

*Form Approved*  
*OMB No. 0704-0188*

Public reporting burden for the collection of information is estimated to average 1 hour per response, including the time for reviewing instructions, searching existing data sources, gathering and maintaining the data needed, and completing and reviewing the collection of information. Send comments regarding this burden estimate or any other aspect of this collection of information, including suggestions for reducing this burden, to Washington Headquarters Services, Directorate for Information Operations and Reports, 1215 Jefferson Davis Highway, Suite 1204, Arlington VA 22202-4302. Respondents should be aware that notwithstanding any other provision of law, no person shall be subject to a penalty for failing to comply with a collection of information if it does not display a currently valid OMB control number.

1. REPORT DATE <b>DEC 2002</b>	2. REPORT TYPE	3. DATES COVERED <b>00-00-2002 to 00-00-2002</b>			
4. TITLE AND SUBTITLE <b>Analysis of One Year of Zero-Baseline GPS Common-View Time Transfer and Direct Measurement Using Two Co-Located Clocks</b>		5a. CONTRACT NUMBER			
		5b. GRANT NUMBER			
		5c. PROGRAM ELEMENT NUMBER			
6. AUTHOR(S)		5d. PROJECT NUMBER			
		5e. TASK NUMBER			
		5f. WORK UNIT NUMBER			
7. PERFORMING ORGANIZATION NAME(S) AND ADDRESS(ES) <b>NMi Van Swinden Laboratorium,P.O. Box 654,2600 AR Delft, the Netherlands,</b>		8. PERFORMING ORGANIZATION REPORT NUMBER			
9. SPONSORING/MONITORING AGENCY NAME(S) AND ADDRESS(ES)		10. SPONSOR/MONITOR'S ACRONYM(S)			
		11. SPONSOR/MONITOR'S REPORT NUMBER(S)			
12. DISTRIBUTION/AVAILABILITY STATEMENT <b>Approved for public release; distribution unlimited</b>					
13. SUPPLEMENTARY NOTES <b>See also ADM001507. 34th Annual Precise Time and Time Interval (PTTI) Planning Meeting, 3-5 December 2002, Reston, VA</b>					
14. ABSTRACT <b>As part of the Galileo project of Early Trials on Time Synchronization Techniques and Calibration Issues, the (near) zero-baseline GPS Common-View Time Transfer and Direct Measurement (using a Time Interval Counter) results between the time scales of two co-located clocks during 2001 were analyzed. This was done to identify the obtainable uncertainty levels with these techniques. The result of the analysis is presented. The baseline of the antennas of the two single-channel NBS-type GPS C-V receivers was 2 m, so multi-path influence is not excluded. The uncertainties from statistical origin (Type A evaluation) were determined by means of MDEV and TDEV. The uncertainties from other sources (Type B evaluation) were determined from calibrations. The TDEV of the GPS C-V result was less than 0.4 ns at averaging times &gt; 1 day, and at shorter averaging times TDEV was about 1 ns.</b>					
15. SUBJECT TERMS					
16. SECURITY CLASSIFICATION OF:			17. LIMITATION OF ABSTRACT <b>Same as Report (SAR)</b>	18. NUMBER OF PAGES <b>10</b>	19a. NAME OF RESPONSIBLE PERSON
a. REPORT <b>unclassified</b>	b. ABSTRACT <b>unclassified</b>	c. THIS PAGE <b>unclassified</b>			

second high-performance cesium clock (HP5171A) followed by a microstepper generates a backup time scale called UTC (VSB) and serves as reference for the second GPS receiver (VSL18).

## 2.2 ACCURACY AND UNCERTAINTY EXPRESSION

The ISO Guide to the Expression of Uncertainty in Measurement (GUM) [4] and the EAL document EAL-R2 [5] discern two types of uncertainties related to measurements: the uncertainty evaluated from the statistical analysis of the data, denoted Type A evaluation, and indicated by  $u_A$ ; and the uncertainty evaluated from other causes, also denoted Type B evaluation, indicated by  $u_B$ . Type A evaluation includes contributions from random nature. Type A in the field of Time and Frequency is mostly expressed as Allan deviation (ADEV), Modified Allan deviation (MDEV), and Time deviation (TDEV) [1, 2]. Type B evaluation includes estimates of contributions from systematic nature, derived from calibrations, closing errors, etc.

The total combined uncertainty indicated by  $u_C$  is calculated as the root of the sum of the quadratics of  $u_A$  and  $u_B$ . To obtain a confidence level of 95%, a coverage factor  $k = 2$  is generally used. In the form of a formula:  $u_C = 2 \times (\sqrt{(\sqrt{u_A}) + (\sqrt{u_B})})$ . The term “accuracy” should be avoided for measurement results.

## 3 DIRECT CLOCK MEASUREMENT (SHORT CABLE TIC)

### 3.1 DESCRIPTION OF THE DIRECT CLOCK MEASUREMENT SETUP

The differences between the two time scales VSL and VSB are measured once each hour directly with a time interval counter (TIC). A TIC is a device which measures the time interval between the signal applied to its start input compared to the signal applied to its stop input (see Figure 1). The resolution of the measured and displayed time interval in the best TIC can be 10 picoseconds (see Figure 2), while the Type B uncertainty (accuracy) can be 50 ps to 100 ps. The time scale signals and the time outputs from the used GPS receivers are steep pulses occurring once per second (1 pulse per second, 1 PPS). The TIC and the associated coaxial switching system with cables were calibrated. The TIC was calibrated for internal start-stop delay by connecting the start signal to both inputs. The delay in the remaining system was determined by connecting the start signal to the input of the system, where the UTC (VSB) signal was connected. The total correction on the direct measurement data (for the VSB signal) to be applied is -34.6 ns. Outliers in the direct measurement  $\geq 200$  ns have been removed, except for known steps of a multiple of 100 ns. These steps have been corrected.

### 3.2 CORRECTED DIRECT DATA

The direct VSL-VSB data are corrected for known time steps, and the result is shown in Figure 3. The last part of the Figure 3 shows a straight line. This is not an error, but during this period the second clock B was been replaced by Clock A, so during this period a common clock was used for the direct clock measurements.

### 3.3 CHARACTERIZATION AND ANALYSIS

The MDEV and TDEV of the direct clock difference results are shown in Figure 4. The MDEV shows a straight line with a slope of  $^{-1/2}$  dependence on  $\tau$  from 3600 s (1 h) to about  $4 \cdot 10^{+5}$  s (4 days). Then some flattening occurs.

For TDEV it is also a straight line, but with a slope of  $+1/2$  dependency on  $\tau$  from 200 ps at 1 h to 2.3 ns at 4 days. Please realize here that these results are not giving only the time transfer properties; they include also the properties of the two clocks.

## 4 THE CO-LOCATED GPS C-V METHOD

### 4.1 INDIRECT MEASUREMENT SETUP USING GPS RECEIVERS IN COMMON-VIEW

Using the GPS Common-View technique, two UTC time scales have been compared using two GPS time transfer receivers. This co-located GPS (Galileo) Common-View time transfer method (Figure 1) is identical to the general GPS C-V method. The difference is that the receivers and their antennas are now co-located within 2 m, thus near zero-baseline. In such case the ionosphere and troposphere delays are identical and cancel completely in the GPS C-V result. The only differences are related to the multi-path, antenna, cables, and receiver delay differences. So this method can be used to measure the optimum, but realistic time comparison properties (realistic upper performance limit) for GPS C-V using these two co-located, mutually independent receivers.

The two GPS receivers VSL01 and VSL18 used for this experiment at VSL are Time Transfer receivers of the NBS-type, single-channel C/A code tracking.

### 4.2 CO-LOCATED GPS C-V DATA RESULTS

The 1-year raw data from VSL01 and from VSL18 have been corrected for known jumps. Each individual data point of the 13-minute sessions according to the BIPM schedule for both receivers is shown in Figure 5.

The clock difference data of the VSL-GPS and VSB-GPS data, named  $(\text{VSL-VSB})_{\text{gps}}$  data, are also shown in Figure 5 (green, upper trace). The last part of this trace shows a straight line. This is not an error, but during this period after MJD 52225 the second clock B generating time scale VSB was been replaced by the Clock A that generated also the first time scale UTC (VSL), so a common clock was used for both GPS receivers during this period. The cesium-beam tube of Clock B was at its end-of-life.

### 4.3 CHARACTERIZATION AND ANALYSIS

The MDEV and TDEV of the clock difference data are shown in Figure 6. The TDEV of this near zero-baseline GPS C-V time transfer result slowly increases with averaging time  $\tau$  from 1 ns at 1 h to 2 ns at 2 days and reaches 10 ns at  $\tau$  of 40 d.

The frequency transfer result between the clocks shows a modified Allan deviation of  $2 \cdot 10^{-14}$  at 1 day and has a floor of  $5 \cdot 10^{-15}$  at  $> 20$  d. Please realize that these results are not giving only the time transfer properties; they include also the properties of the two clocks.

## 5 DIFFERENCE GPS C-V AND DIRECT

### 5.1 INTERPOLATED AND CORRECTED DIFFERENTIAL DATA

The difference between the direct method and GPS C-V is shown in Figure 7. This difference is ((VSL-VSB) direct - (VSL-VSB) GPS). After MJD 52225, the VSL clock was replaced the VSB clock, so from that time on it is common clock as can be seen from the straight noiseless (VSL-VSB) direct difference. The yellow, lower trace is the “double” difference. There is no difference visible during the period of common clock, so both clocks have similar stabilities.

### 5.2 CHARACTERIZATION AND ANALYSES

The result for the difference of the direct minus the GPS C-V results are shown in Figure 8. It can be seen that the TDEV is at 1 ns level for  $\tau < 40\,000$  (0.5 d), then becomes for  $\tau \geq 1$  day rather constant at the 400 ps level ( $u_A$ ) for  $\tau$  up to 20 d. The latter reflects mainly the differential stability, the sum of all other long-time uncorrelated factors, of the two GPS receiver results, while the first shows multi-path, diurnal differential temperature dependency, and other short-time uncorrelated sources such as basic receiver phase noise.

## 6 CONCLUSIONS

### 6.1 TYPE A UNCERTAINTY EVALUATION

For near zero-baseline GPS C-V, the uncertainty from statistical origin Type A ( $u_A$ ) is for  $k = 1$  equal to the TDEV, and so is 1 ns for  $\tau < 40\,000$  s ( $= 0.5$  d), and 400 ps for  $\tau \geq 1$  to 20 days.

### 6.2 TYPE B UNCERTAINTY EVALUATION

The average difference between the direct method and the GPS C-V method for time transfer without any correction was + 46 ns. Application of the necessary correction of -34.6 ns for the VSB direct data brings the difference (direct - GPS C-V) to the value  $46 - 34.6 = +11.4$  ns.

Application of a correction of +11.7 ns on the BIPM calibration of VSL01 in 1998 [3] to the VSL01 data and a correction of +1.8 ns to the VSL18 data give a correction for the GPS C-V results of  $+11.7 - 1.8 = +9.9$  ns. This reduces the difference (direct - GPS C-V), the closing error, to  $+11.4 - 9.9 = +1.5$  ns ( $= u_B$ ). This is an excellent result for Type B evaluation  $u_B$ .

### 6.3 COMBINED UNCERTAINTY EVALUATION

Taking the direct measurement as reference, then the total combined uncertainty  $u_C$  for the co-located, near-zero-baseline GPS C-V can be estimated to be for  $k = 2$ , at a 95% confidence interval (see Section 2.2), up to 0.5 d averaging time: 3.6 ns, and for 1 to 20 day averaging time: 3.1 ns.

## 6.4 REMARKS

Improvements in the GPS C-V results could result from application of postprocessed data: satellite orbits, measured ionosphere data, measured troposphere data, and also from improvement of temperature sensitivity and multi-path in receiver equipment and cables.

## 7 ACKNOWLEDGMENTS

This work was done as part of a European Space Agency Study Contract (ESTEC no 15551/01/NL/DS) and the authors want to acknowledge especially the support of Dr. J. Hahn (ESTEC) to this study.

## 8 REFERENCES

- [1] Rec. ITU-R TF.538-3, *"Measures for random instabilities in frequency and time (phase),"* ITU-R Recommendations, **Time Signals And Frequency Standards Emissions**, Volume **2000**, TF Series, ISBN 92-61-08851-1, 2 001 (ITU Radio Communication Bureau, Geneva), pp. 111-119.
- [2] **Handbook Selection and Use of Precise Frequency and Time Systems**, 1997, ISBN 92-61-06511-2 (ITU Radio Communication Bureau, Geneva).
- [3] W. Lewandowski and P. Moussay, 1998, *"Differential time corrections for GPS time equipment located at the OP, VSL, NPL, DTAG, PTB, TUG, IEN, ROA, IPQ and OCA: 3rd Evaluation"* (Bureau International des Poids et Mesures, Pavillon de Breteuil, F-92312 Sèvres Cedex, France).
- [4] *"Guide to the Expression of Uncertainty in Measurement"* (International Organization for Standardization, Geneva), ISBN 92-67-10188-9, first edition, 1993, corrected and reprinted 1995.
- [5] *"Expression of the uncertainty of Measurement in Calibration,"* European cooperation for Accreditation of Laboratories, publication reference: EAL-R2, edition 1, April 1997.
- [6] G. de Jong and W. Lewandowski, 1997, *"Glonass/GPS Time Transfer and the problem of the Determination of Receiver delays,"* in Proceedings of the 29<sup>th</sup> Precise Time and Time Interval (PTTI) Systems and Applications Meeting, 2-4 December, Long Beach, California, USA (U.S. Naval Observatory, Washington, D.C.), pp. 229-240.
- [7] G. de Jong and W. Lewandowski, 1998, *"Glonass/GPS Time Transfer and the problem of the Determination of Receiver delays,"* in Proceedings of the 12<sup>th</sup> European Frequency and Time Forum (EFTF), 10-12 March 1998, Warsaw, Poland (Tele & Radio Research Institute, Warsaw), pp. 79-86.



**Co-located Clocks through 1:GPS Common-View and 2: Direct Time Interval Counter measurement**

Time difference 1 (A-B) = (A-C) - (B-C) + delay diff.  
 Time difference 2 (A-B) = TIC reading

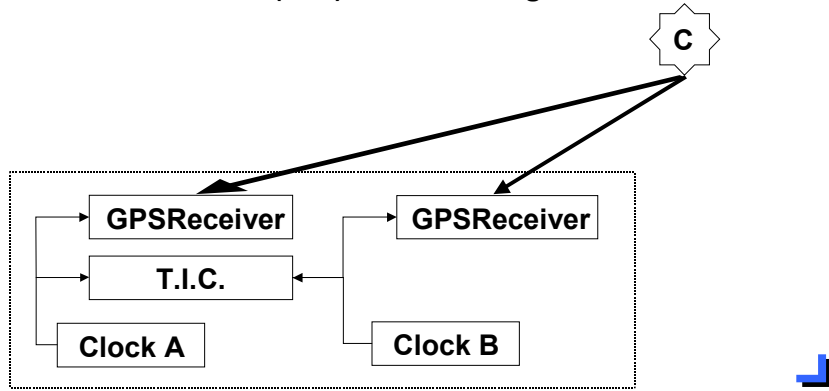

Figure 1. Co-located measurement setup.

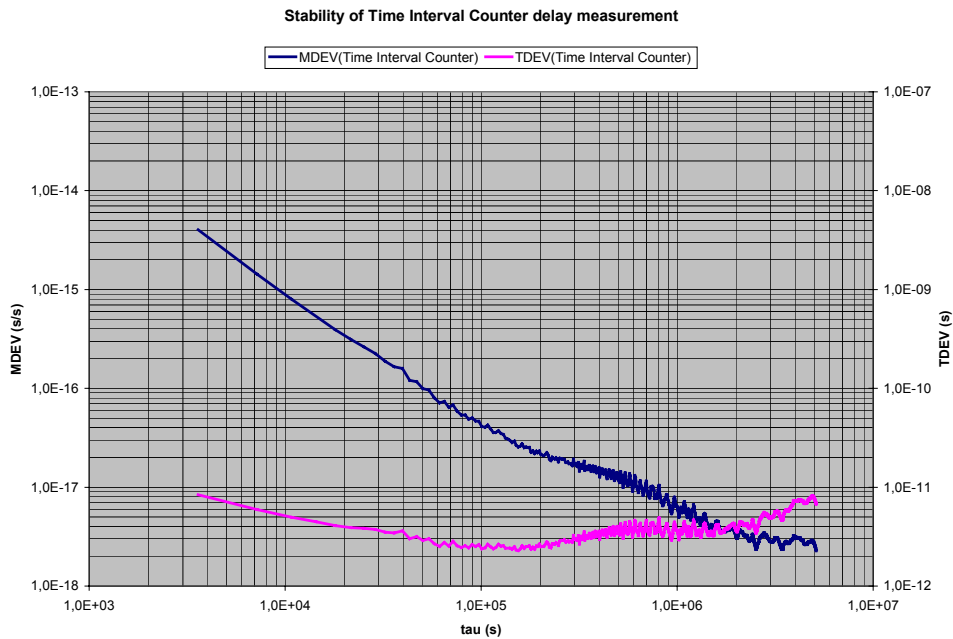

Figure 2. Time interval counter MDEV and TDEV.

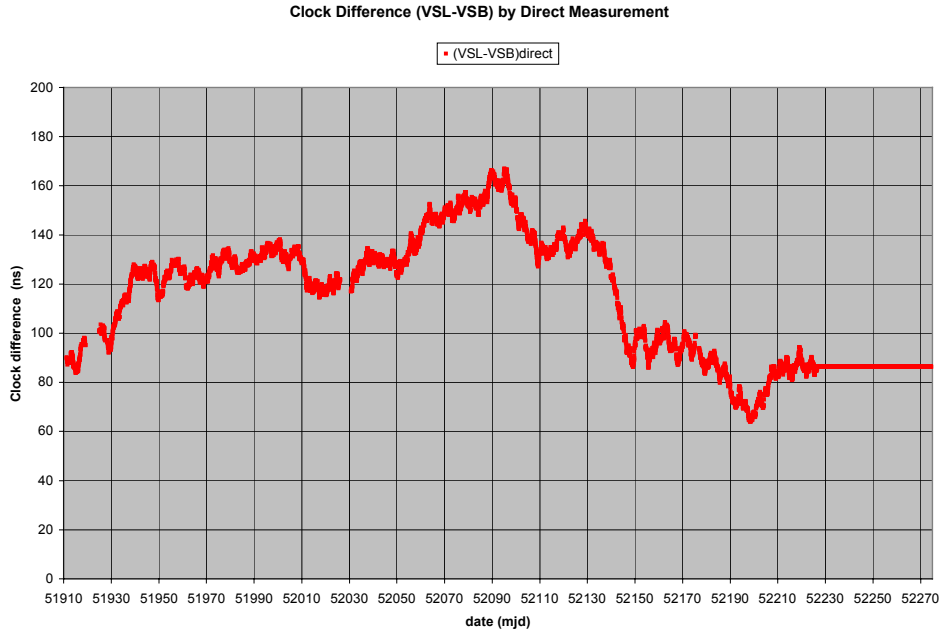

Figure 3. Difference of VSL - VSB clocks by direct measurement.

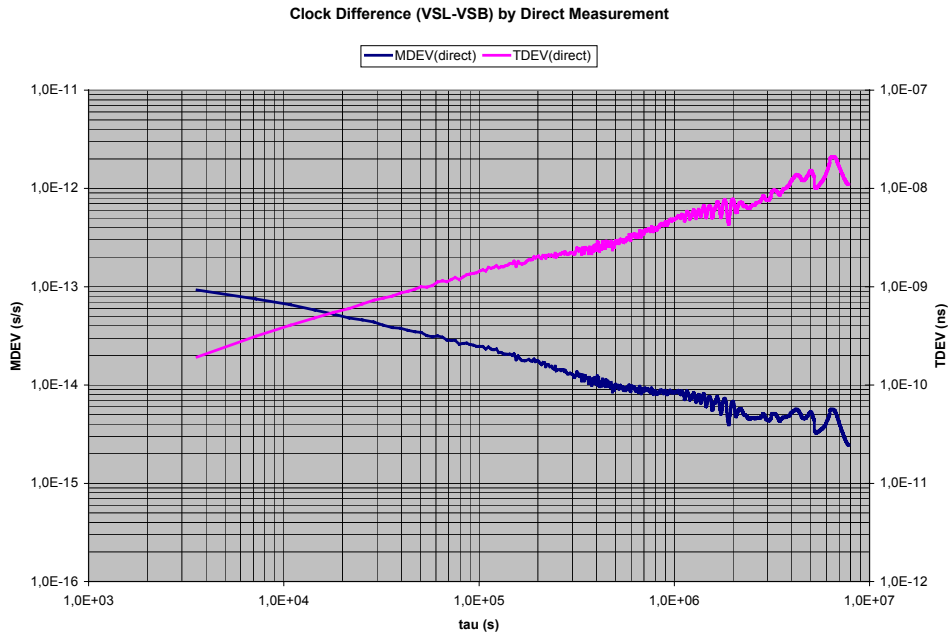

Figure 4. Characterization of VSL - VSB clocks by direct measurement.

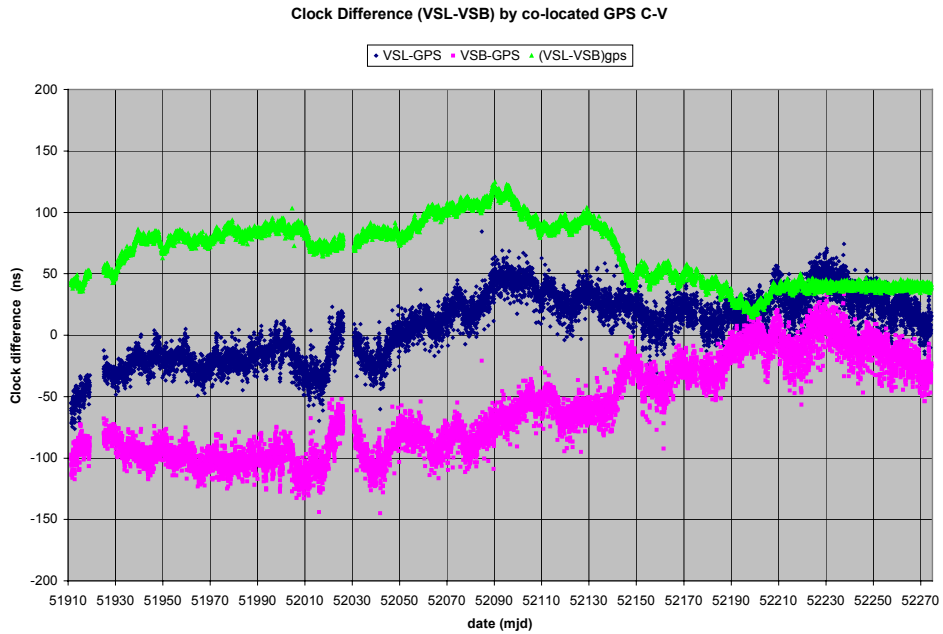

Figure 5. GPS C-V data and the clock difference (VSL – VSB) by GPS C-V.

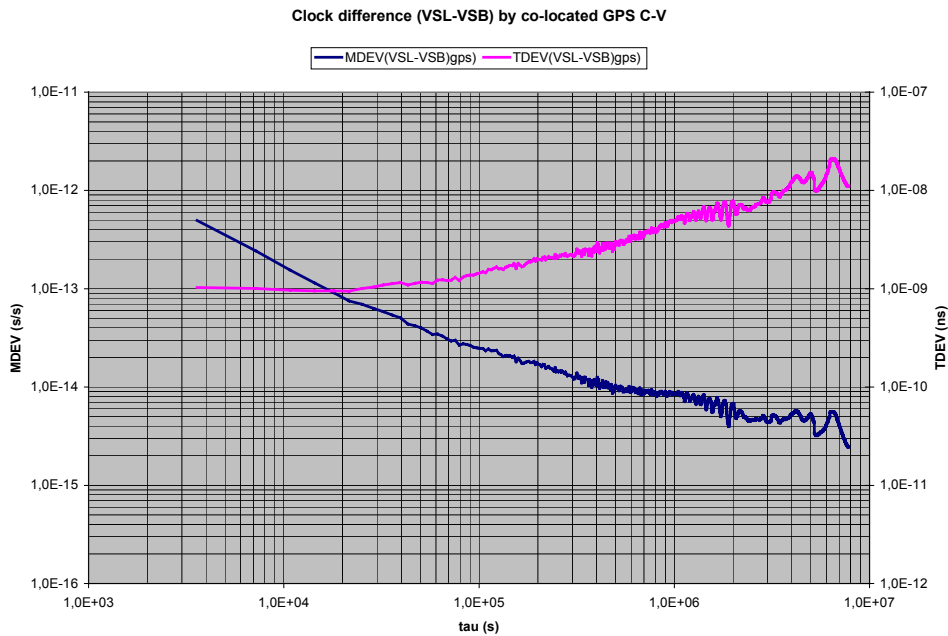

Figure 6. Characterization of clock difference (VSL - VSB) using co-located GPS C-V.

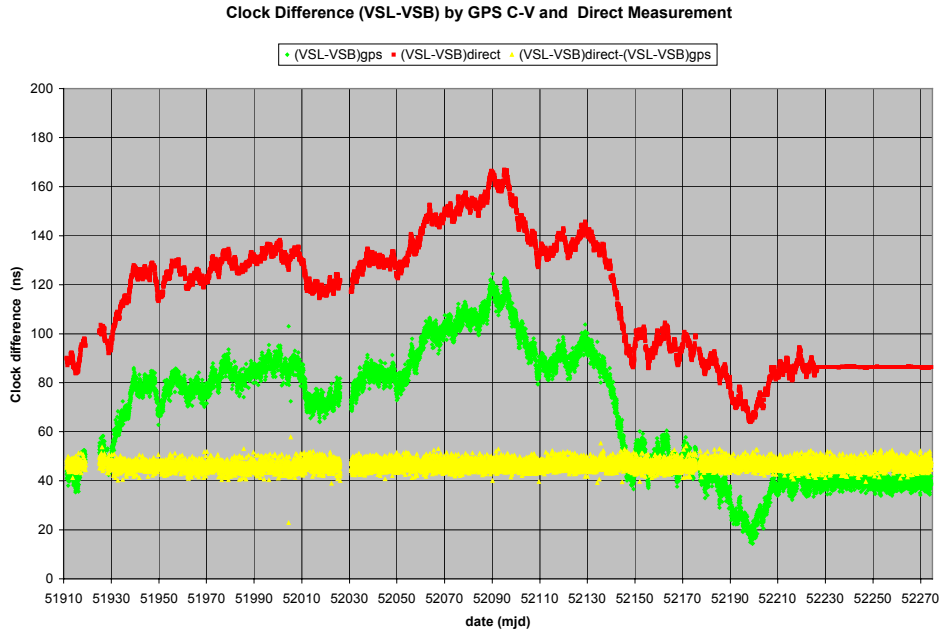

Figure 7. Difference between co-located GPS C-V and direct clock measurements.

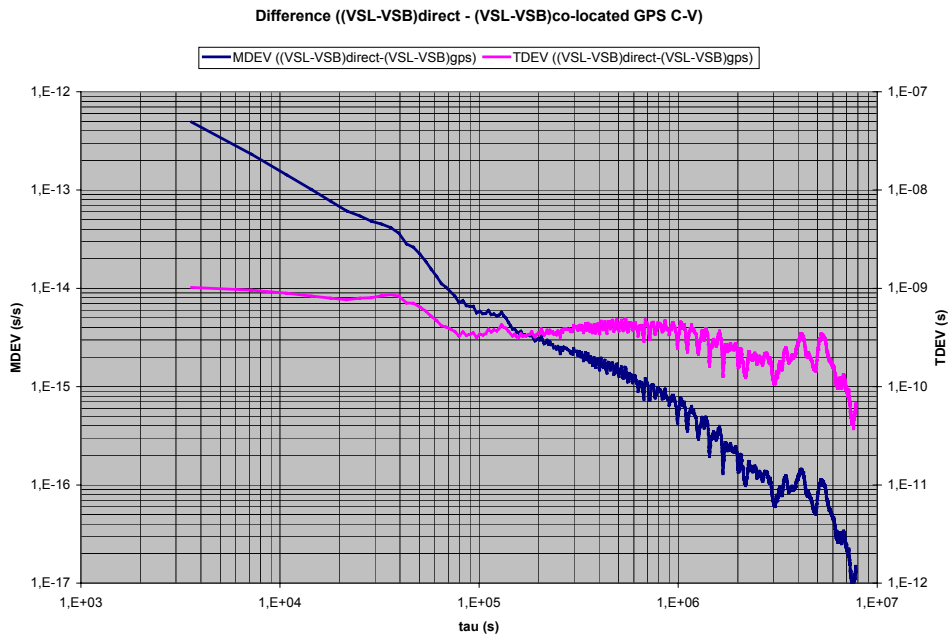

Figure 8. Characterization of the difference between co-located GPS C-V and direct measurements.

## **QUESTIONS AND ANSWERS**

**CHRISTINE HACKMAN (University of Colorado):** My question is on your time deviation plot, after about a day, it looks like you have flicker PM at about 400 ps. I was wondering if you know what the source of that is.

**GERRIT de JONG:** I think these are the remaining differences for the long term. So that could be the temperature coefficients of both systems. It could be in first order the same, but not exactly the same. So then you could have that remaining fluctuation, depending on temperature or any other thing, which does not compensate fully in the two receivers. They are of the same kind, the same design, but, of course, there are individual differences in the antennas, mainly, because there you have the biggest environmental influence that could still be present. One antenna is directly coming from NIST at that time. The other is an Allen Osborne antenna. So they are not from the same unit, and there could be some remaining difference.