

DESIGN CONCEPT FOR THE MICROWAVE INTERROGATION STRUCTURE IN PARCS

G. J. Dick and W. M. Klipstein
Jet Propulsion Laboratory, California Institute of Technology
Pasadena, CA 91007, USA
E-mail: Klipstein@jpl.nasa.gov

T. P. Heavner and S. R. Jefferts
National Institute of Standards and Technology
Boulder, CO 80305, USA

Abstract

In this paper we will describe key aspects of the conceptual design of the microwave interrogation structure in the laser-cooled cesium frequency standard that is part of the Primary Atomic Reference Clock in Space (PARCS) experiment. The PARCS standard uses balls of cold atoms launched in a pulsed beam configuration. The microwave interrogation will take place in two independent high- Q ($\sim 20,000$) cavities operated in the TE_{011} mode. The cavities will be operated off resonance by several line widths, with a resonant structure delivering the microwaves to the two cavities. One persistent problem related to the end-to-end phase shift has been the extreme temperature sensitivity of the phase inside the cavities to that just outside the cavities. The end-to-end phase difference must ultimately be known to around 3 microradians, and stable long enough to allow measurement of the shift as well as to allow normal clock operation. Operating the cavities off-resonance reduces this sensitivity more strongly than reducing the cavity Q .

INTRODUCTION

This paper will address the conceptual implementation of the microwave interrogation structure in the Primary Atomic Reference Clock in Space (PARCS) experiment [1], focusing on the end-to-end phase shift, which has been a dominant systematic frequency offset in atomic-beam frequency standards [2]. The advent of laser-cooled atomic fountains eliminated the end-to-end shift as the atoms were interrogated by the same microwave cavity, once on the way up and once on the way back down. PARCS contains a laser-cooled cesium frequency standard designed to operate in the microgravity environment aboard the International Space Station (ISS). This standard shares many of the benefits of a laser-cooled standard on Earth, but in the absence of gravity must be operated in a modified beam geometry rather than as a fountain, thus reintroducing the end-to-end phase shift. PARCS has a design goal of measuring the end-to-end shift with an uncertainty of $2 \cdot 10^{-17}$, requiring the phase offset between the cavities to be known with an uncertainty of 3 microradians. The main difficulty comes from small changes in temperature, as discussed below. We will show that by operating the cavities off-resonance, we expect we can meet our operational requirements.

Report Documentation Page

Form Approved
OMB No. 0704-0188

Public reporting burden for the collection of information is estimated to average 1 hour per response, including the time for reviewing instructions, searching existing data sources, gathering and maintaining the data needed, and completing and reviewing the collection of information. Send comments regarding this burden estimate or any other aspect of this collection of information, including suggestions for reducing this burden, to Washington Headquarters Services, Directorate for Information Operations and Reports, 1215 Jefferson Davis Highway, Suite 1204, Arlington VA 22202-4302. Respondents should be aware that notwithstanding any other provision of law, no person shall be subject to a penalty for failing to comply with a collection of information if it does not display a currently valid OMB control number.

1. REPORT DATE DEC 2002	2. REPORT TYPE	3. DATES COVERED 00-00-2002 to 00-00-2002	
4. TITLE AND SUBTITLE Design Concept for the Microwave Interrogation Structure in PARCS		5a. CONTRACT NUMBER	
		5b. GRANT NUMBER	
		5c. PROGRAM ELEMENT NUMBER	
6. AUTHOR(S)		5d. PROJECT NUMBER	
		5e. TASK NUMBER	
		5f. WORK UNIT NUMBER	
7. PERFORMING ORGANIZATION NAME(S) AND ADDRESS(ES) California Institute of Technology, Jet Propulsion Laboratory, Pasadena, CA, 91007		8. PERFORMING ORGANIZATION REPORT NUMBER	
9. SPONSORING/MONITORING AGENCY NAME(S) AND ADDRESS(ES)		10. SPONSOR/MONITOR'S ACRONYM(S)	
		11. SPONSOR/MONITOR'S REPORT NUMBER(S)	
12. DISTRIBUTION/AVAILABILITY STATEMENT Approved for public release; distribution unlimited			
13. SUPPLEMENTARY NOTES See also ADM001507. 34th Annual Precise Time and Time Interval (PTTI) Planning Meeting, 3-5 December 2002, Reston, VA			
14. ABSTRACT In this paper we will describe key aspects of the conceptual design of the microwave interrogation structure in the laser-cooled cesium frequency standard that is part of the Primary Atomic Reference Clock in Space (PARCS) experiment. The PARCS standard uses balls of cold atoms launched in a pulsed beam configuration. The microwave interrogation will take place in two independent high-Q (~20,000) cavities operated in the TE011 mode. The cavities will be operated off resonance by several line widths, with a resonant structure delivering the microwaves to the two cavities. One persistent problem related to the end-to-end phase shift has been the extreme temperature sensitivity of the phase inside the cavities to that just outside the cavities. The end-to-end phase difference must ultimately be known to around 3 microradians, and stable long enough to allow measurement of the shift as well as to allow normal clock operation. Operating the cavities off-resonance reduces this sensitivity more strongly than reducing the cavity Q.			
15. SUBJECT TERMS			
16. SECURITY CLASSIFICATION OF:			17. LIMITATION OF ABSTRACT
a. REPORT unclassified	b. ABSTRACT unclassified	c. THIS PAGE unclassified	Same as Report (SAR)
			18. NUMBER OF PAGES 8
			19a. NAME OF RESPONSIBLE PERSON

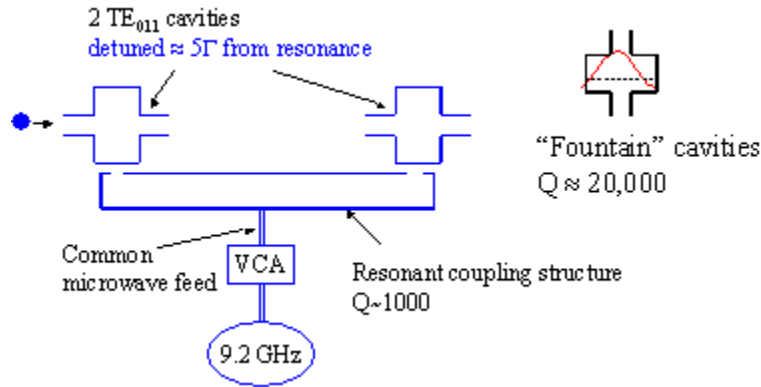

Figure 1. Cartoon of the microwave interrogation structure in PARCS. Atoms are interrogated in two TE₀₁₁ cavities fed by a common resonant coupling structure and common microwave feed. Operation of the cavities off-resonance is critical to reducing the temperature coefficient of the end-to-end phase shift. The two cavities will be operated in phase with each other, and the atoms will be interrogated using phase modulation. The curved line inside the fountain cavity represents the field in the cavity.

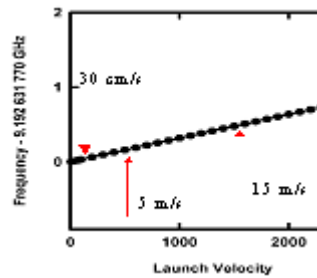

Figure 2. The end-to-end phase difference between the two cavities can be measured by comparing the center frequency at different launch velocities. A correction can then be applied to the measured frequency at the normal launch velocity of 0.3 m/s.

MICROWAVE INTERROGATION STRUCTURE

Microwave interrogation of the balls of cold atoms will take place in two TE₀₁₁ cylindrical cavities similar to those favored in fountain applications. These cavities have large holes through the center, allowing significant numbers of atoms to get through the cavities, while having desirable phase and intensity flatness and symmetry across the aperture. The cavities are expected to have a quality factor, Q , of approximately 20,000. The cavities will be detuned from the cesium resonance by approximately 5Γ , where Γ is the full-width at half-maximum (FWHM) of the cavities. The cavities will be connected by a resonant coupling structure as shown in Figure 1. The coupling structure itself will have a Q of around 1000 and be driven by a single microwave source located outside the physics package. The two cavities will be in phase with each other, and phase modulation interrogation will be implemented by switching the phase of the entire structure in between balls of atoms.

In a previous paper [3], we discussed using independent cavity phase control, with phase modulation implemented by reversing the phase in the second cavity between balls. Various implementations of this strategy all had difficulty with the temperature coefficient of the phase inside each cavity. The implementation of off-resonant cavities appears to solve this problem, and we have chosen the current design as our baseline as the most straightforward implementation meeting our requirements on end-to-end phase shift.

MEASURING THE END-TO-END PHASE SHIFT

As discussed in [3], in a laser-cooled standard in microgravity, it is possible to measure the end-to-end phase shift by varying the atomic velocity and extrapolating to zero velocity. In short, the laser-cooled source has a very narrow velocity distribution with a selectable mean velocity. The end-to-end phase offset is measured by comparing the observed center frequency at two “fast” launch velocities, such as 5 and 15 m/s. The frequency difference can be attributed to the end-to-end phase offset, as for these two velocities all other frequency offsets (other than the calculable second-order Doppler shift) are common. With the measured phase offset between the cavities, a correction can be made to the frequency measured with the standard launch velocity of 0.30 m/s. This is shown graphically in Figure 2.

TEMPERATURE COEFFICIENT OF THE END-TO-END PHASE

If the end-to-end phase were stable, then the offset could be measured only once. With the use of the resonant, relatively high- Q TE₀₁₁ cavities, however, there is a strong dependence on the phase inside the cavity, $\phi_{1,2}$, with the phase delivered to the cavity, $\phi'_{1,2}$, for cavities 1,2 respectively. This phase difference depends on the detuning of the cavity, and hence its temperature, as shown in Figure 3. With the cavities operated nominally on resonance, the slope of the phase difference, $\Delta\phi = \phi - \phi'$ is a maximum, with a value for our cavities of approximately 1 radian/K. Such sensitivity would require a temperature stability of 3 microKelvin to maintain a stable phase difference at the required level. Such temperature stability is well beyond our capabilities, requiring a nearly continuous monitoring of the end-to-end shift. This would have significant impact on our ability to run in our nominal configuration, especially in light of the need for significant changes in microwave power to match the fast launch velocities and the time-varying phase delays coming from such changes in power

As can be seen from Figure 3, the phase slope with detuning (and hence temperature) is dramatically reduced off resonance, reduced essentially as the square of the detuning measured in half line widths. Operating the cavities detuned by 5Γ , therefore, reduces the temperature coefficient by 100, at the same time requiring 100 times more microwave power.

COMPARISON OF DETUNED CAVITIES TO REDUCED CAVITY Q

Rather than detuning the cavities, reduction of the phase slope to temperature could also be accomplished by spoiling the Q of the cavities, through increased coupling strength, for example. Such a scenario is indicated in Figure 4, which shows a comparison between the loaded Q case operated on resonance and the use of detuned cavities. For the reduced Q , the reduction in phase slope is linear in the broadening, while still requiring an increase of microwave power by the square of the broadening. Figure 4 exhibits the great benefit of operating the cavities off resonance.

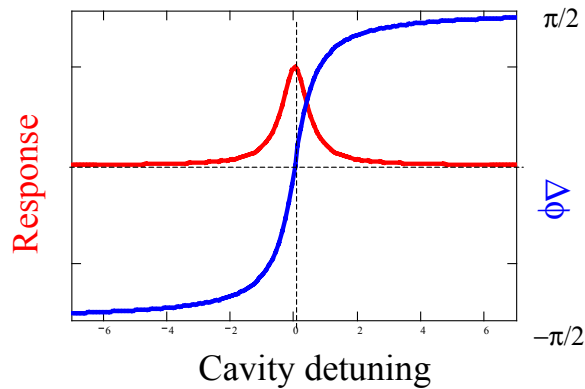

Figure 3 Plot of the cavity response and phase difference, $\Delta\phi = \phi - \phi'$, between the inside and outside of the cavity as a function of detuning from the operating frequency.

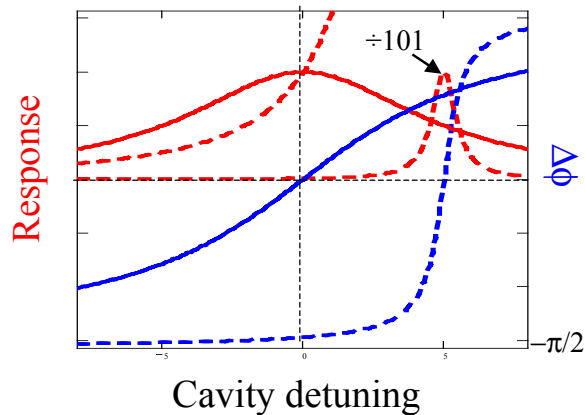

Figure 4 Plot of cavity response (red) and inside-outside cavity phase difference (blue) for the case of reduced Q (solid lines) and for detuned cavities (dashed lines). The cavity response, divided by 101, is also shown since the detuned cavity response is off scale. The reduction in phase slope for detuned cavities is as the square of the detuning in half line widths, while scaling linearly in the broadening of the cavity Q at constant microwave power requirements. This plot illustrates the benefits of operating with the cavities detuned.

RESONATING THE COUPLING STRUCTURE

Resonating the coupling structure reduces sensitivity to changes in the lengths of the two arms of the cavity, essentially by the Q. It also greatly relaxes the requirements on the location of the holes in the structure used to feed the cavities, as the phase becomes relatively flat as a function of location, as shown in Figure 5 below. This reduces the difficulty caused by varying temperature gradients across the structure, which is expected to be approximately 0.75 m long and has a design requirement allowing the temperature to vary by 50 mK from end to end.

Resonating the coupling structure creates a phase variation, $\phi'' - \phi'$, between the inside of the coupling structure and the common feed, as shown in Figure 5. This change in phase will be common mode to the two cavities, so to first order such variations do not cause an error. While the phase change is common mode to the two cavities, it is not common mode to a single atom to the extent that the phase changes in the time it takes for it to travel from the first cavity to the second. For a linear slope of temperature, this corresponds to a fixed (but bounded) frequency error. Such a shift would also be present in a fountain, for which a temperature slope of 30 microK/s would correspond to a shift of 1×10^{-15} . Since the temperature is bounded, the average shift would be expected to be zero, but can be finite and potentially large over shorter times.

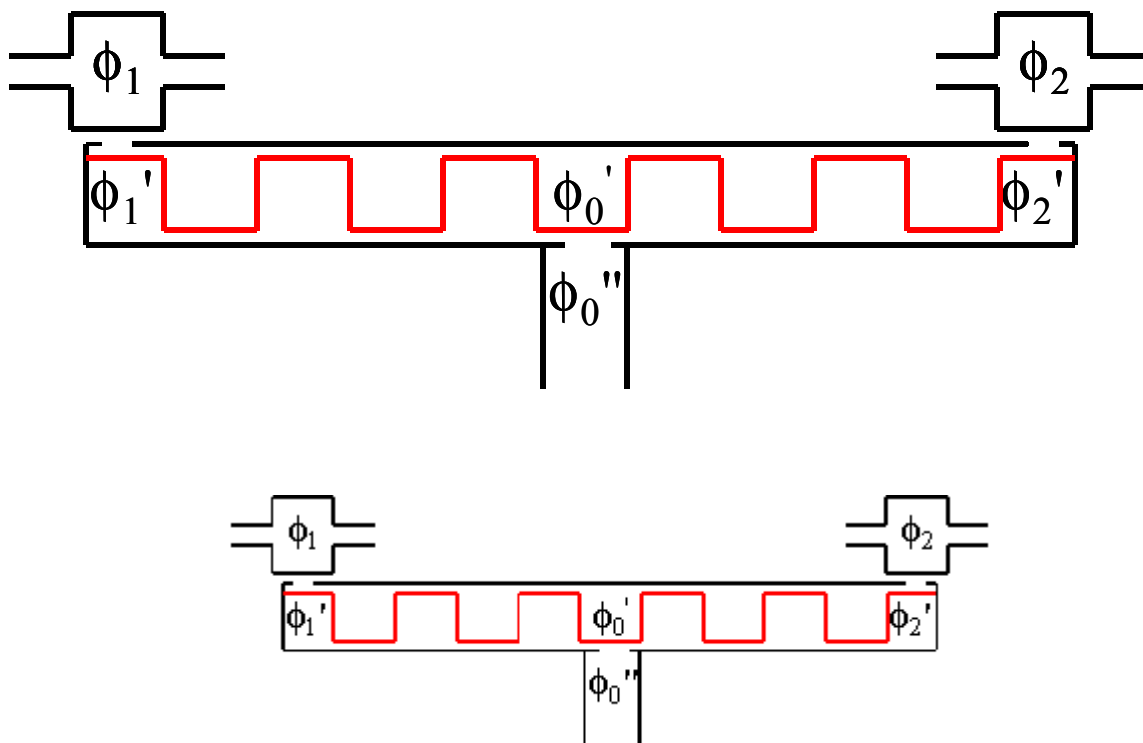

Figure 5. Phase variation in the resonant microwave coupling structure. Resonating this structure creates a phase difference between the inside and outside of the structure that is common to the two cavities. Individual atoms will experience a phase offset if this phase varies during the time of flight between the two cavities.

MODELED THERMAL STABILITY OF PARCS

Operating the cavities off resonance reduces the temperature coefficient of the end-to-end phase shift, but tight temperature regulation is still required to meet our requirements. Preliminary thermal models of the PARCS microwave interrogation region show a thermal time constant of approximately 30,000 seconds, which is to be compared to the 5000-second ISS orbital period. In the model, sudden changes in the thermal base-plate temperature of 5 K resulted in changes in temperature of approximately 20 mK using a thermostatic temperature controller. The use of a proportional temperature controller and estimates of the time rate of change of the base plate suggest that temperature variations over 1 day will be only a few mK. Such stability is aided by the absence of convection and the weak coupling of the physics package to the external environment. Taking 3 mK to be the variation of temperature between cavity 1 and cavity 2,

and assuming the cavities are detuned 10 half line widths, variations in the end-to-end phase over a single day would be expected to be 30 microradians, corresponding to a shift of 2×10^{-16} . This is comparable to our 1-day stability, from which we conclude that measuring the end-to-end phase shift once per day will be sufficient under the assumptions outlined here.

CONCLUSION

We have described a conceptual design of the microwave interrogation structure for the PARCS cesium frequency standard and shown that it meets our requirements on end-to-end phase shift, subject to daily evaluation of this offset. Critical to the design is the operation of the TE₀₁₁ cavities off of resonance. Detailed design of the microwave coupling structure is underway at the Jet Propulsion Laboratory, California Institute of Technology.

ACKNOWLEDGMENTS

Thermal modeling of the PARCS cesium physics package was done by James Stultz of JPL/CalTech.

Part of the research described in this paper was carried out at the Jet Propulsion Laboratory, California Institute of Technology, under a contract with the National Aeronautics and Space Administration. Part of the research described in this paper is work of the United States government, not subject to US copyright.

REFERENCES

- [1] S. R. Jefferts, et al., 1999, "PARCS: a Primary Atomic Reference Clock in Space," in Proceedings of the 1999 Joint Meeting of the European Frequency and Time Forum (EFTF) and the IEEE International Frequency Control Symposium, 13-16 April 1999, Besançon, France (IEEE Publication 99CH36313), pp. 141-144.
- [2] e.g. A. Bauch, B. Fischer, T. Heindorff, and R. Schroder, 2000, "*Recent Results of Physikalisch-Technische Bundesanstalt's Primary Clock CS1*," **IEEE Transactions on Ultrasonics, Ferroelectrics, and Frequency Control**, **UF47**, 443-448; W. D. Lee, J. H. Shirley, and R. E. Drullinger, 1994, "*The Accuracy Evaluation of NIST-7*," **IEEE Transactions on Instrumentation and Measurement**, **IM-44**, 120-123.
- [3] W. M. Klipstein, et al., 2001, "Phase Modulation with Independent Cavity-Phase Control in Laser Cooled Clocks in Space," in Proceedings of the 2001 IEEE International Frequency Control Symposium and PDA Exhibition, 6-8 June 2001, Seattle, Washington, USA (IEEE Publication 01CH37218), pp. 25-32.

QUESTIONS AND ANSWERS

MICHAEL GARVEY (Symmetricom): I assume you are going to run the cavities at the same phase?

BILL KILPSTEIN: Yes, I put up a requirement that they be within $\pi/20$.

GARVEY: Did you look at if there is any advantage to running them out of phase?

KILPSTEIN: We talked about it. Of course, I didn't really talk about how we are running the cesium instrument. But the idea is that we spatially separated balls of laser-cooled atoms, and we just clock the phase 90 degrees with the DDS, basically halfway between balls. If you run the cavities out of phase, then you actually need to switch twice per ball. And we could do that. In the integrated solution, which I didn't talk about, it is better to have them in phase. But, in principle, there would be no problem with that.

DAVE HOWE (National Institute of Standards and Technology): What is the line width of the cavity that you are using? You say that you are operating five line widths.

KILPSTEIN: Five-hundred kilohertz.

HOWE: So you are operating 1.5 megahertz away from the normal resonance of the cavity, is that what I understand?

KILPSTEIN: Two and a half megahertz. That is a parameter that we can tune a little bit when we do the total system design. But we are in a parameter space where we feel like we have –

HOWE: The question is, if you have this huge response, 100 times more power in the cavity, what is the atom actually seeing? Have you looked at the issue of transition probability on that large spur, away from the centerline?

KILPSTEIN: I think the real penalty that we might pay is that you run off-resonance, you have to crank the power up to have a higher traveling wave component in the cavity. So the standing wave component stays the same. But I think there is a chance of having a much higher distributed cavity phase shift, for example.

HOWE: Well, the real central point is that there is some noise out there from your RF source. And that will be enhanced.

KILPSTEIN: Yes. Our look at that – I think we are okay with it.

