

# DEVELOPMENT OF TIMING ARCHITECTURE FOR A SECURE GLOBAL COMMUNICATIONS NETWORK

**G. Shaton**  
**Eagle Alliance**  
**132 National Business Parkway**  
**Annapolis Junction, MD 20701, USA**

## Abstract

*This paper explores the historical development of the need for synchronization and syntonization in secure communications networks. After laying the historical background, the author looks at the current state of Master Station clocks in these networks and the issues that need to be addressed in formulating a timing architecture to support a large global communications network. Some of the issues discussed are stability, accuracy, reference sources, and injection of timing into several communication technologies. The paper also looks at the parts of a master station clock and their relationship to various entities in a telecommunication circuit.*

## DEVELOPMENT OF TIMING FOR SECURE NETWORKS

Before the advent of modern communication networks, the majority of the Department of Defense (DoD) communication links were simple point-to-point circuits consisting of a pair of encryption devices and possibly a *time division multiplexer* (TDM). The circuit paths were terrestrial, and the speed of the circuits was typically 9600 baud or less. Timing was not a major concern. Figure 1 shows how a typical multiplex circuit of this era (1970's) was timed.

The next major step in the communication evolution was the addition of satellites in the circuit path (1980's). Since early communication satellite orbits were not geosynchronous, a new problem was introduced into the timing of these communication links, namely variable path delay. This resulted in a Doppler effect on the received data signal. This problem was solved by adding a buffer to the receive side. Now the need for timing arose, since a fixed local clock was required to take the data from the buffer and input it at a fixed rate into the local encryption device (and possibly a multiplexer). Since the circuit rates were still slow (maximum of 64 KBPS), the use of a temperature-controlled quartz oscillator with a stability of parts in  $10^{-8}$  was adequate. See Figure 2.

## Report Documentation Page

*Form Approved*  
*OMB No. 0704-0188*

Public reporting burden for the collection of information is estimated to average 1 hour per response, including the time for reviewing instructions, searching existing data sources, gathering and maintaining the data needed, and completing and reviewing the collection of information. Send comments regarding this burden estimate or any other aspect of this collection of information, including suggestions for reducing this burden, to Washington Headquarters Services, Directorate for Information Operations and Reports, 1215 Jefferson Davis Highway, Suite 1204, Arlington VA 22202-4302. Respondents should be aware that notwithstanding any other provision of law, no person shall be subject to a penalty for failing to comply with a collection of information if it does not display a currently valid OMB control number.

1. REPORT DATE <b>NOV 2001</b>	2. REPORT TYPE	3. DATES COVERED <b>00-00-2001 to 00-00-2001</b>	
4. TITLE AND SUBTITLE <b>Development of Timing Architecture for a Secure Global Communications Network</b>		5a. CONTRACT NUMBER	
		5b. GRANT NUMBER	
		5c. PROGRAM ELEMENT NUMBER	
6. AUTHOR(S)		5d. PROJECT NUMBER	
		5e. TASK NUMBER	
		5f. WORK UNIT NUMBER	
7. PERFORMING ORGANIZATION NAME(S) AND ADDRESS(ES) <b>Eagle Alliance, 132 National Business Parkway, Annapolis Junction, MD, 20701</b>		8. PERFORMING ORGANIZATION REPORT NUMBER	
9. SPONSORING/MONITORING AGENCY NAME(S) AND ADDRESS(ES)		10. SPONSOR/MONITOR'S ACRONYM(S)	
		11. SPONSOR/MONITOR'S REPORT NUMBER(S)	
12. DISTRIBUTION/AVAILABILITY STATEMENT <b>Approved for public release; distribution unlimited</b>			
13. SUPPLEMENTARY NOTES <b>See also ADM001482. 33rd Annual Precise Time and Time Interval (PTTI) Systems and Applications Meeting, 27-29 Nov 2001, Long Beach, CA</b>			
14. ABSTRACT <b>This paper explores the historical development of the need for synchronization and syntonization in secure communications networks. After laying the historical background, the author looks at the current state of Master Station clocks in these networks and the issues that need to be addressed in formulating a timing architecture to support a large global communications network. Some of the issues discussed are stability, accuracy, reference sources, and injection of timing into several communication technologies. The paper also looks at the parts of a master station clock and their relationship to various entities in a telecommunication circuit.</b>			
15. SUBJECT TERMS			
16. SECURITY CLASSIFICATION OF:			17. LIMITATION OF ABSTRACT <b>Same as Report (SAR)</b>
a. REPORT <b>unclassified</b>	b. ABSTRACT <b>unclassified</b>	c. THIS PAGE <b>unclassified</b>	
			18. NUMBER OF PAGES <b>14</b>
			19a. NAME OF RESPONSIBLE PERSON

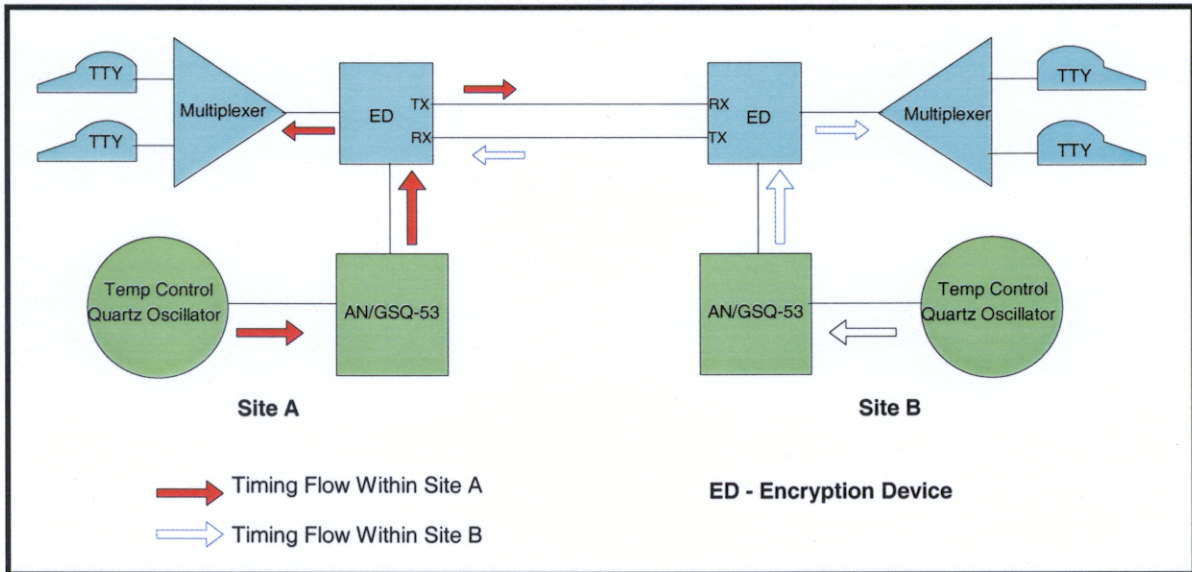

Figure 1: Typical Timing for Simple Multiplexer Link (1970).

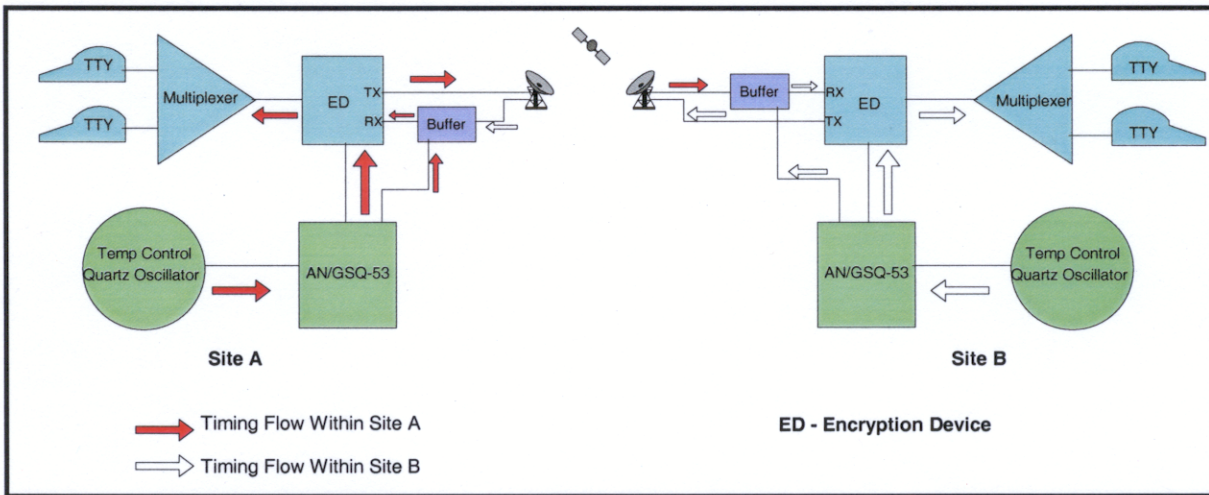

Figure 2: Typical Timing for Early Satellite Link (1980's).

The next development was the use of T-1 and E-1 circuits. These were considered wideband, and the need for a stable clock (with a stability of parts in  $10^{-10}$ ) was obvious. At this juncture, the design of Master Station Clocks was based upon using Loran-C receivers to discipline quartz oscillators. At this point in the evolution of communications systems, many of the point-to-point circuits were placed on multiplexed links. This introduced an increasing number of tandem or pass-through circuits. Another technological change in this time frame was that more outside continental U.S. (OCONUS) circuits were being delivered via satellite, and the use of TDM multiplexers had become widespread. See Figure 3.

The next major improvement in our communication plant involved using circuits that were still point-to-point, but now the rates on these circuits rose much higher, up to 13 MBPS on some circuits. These new multiplexers permitted the use of asymmetrical bandwidth (the transmit and receive rates are different).

In addition, isochronous channels were now available, as well as the normal asynchronous and synchronous channels. These rates demanded better station timing, which led to the migration to atomic clocks (cesium and rubidium oscillators) at almost all sites. See Figure 4.

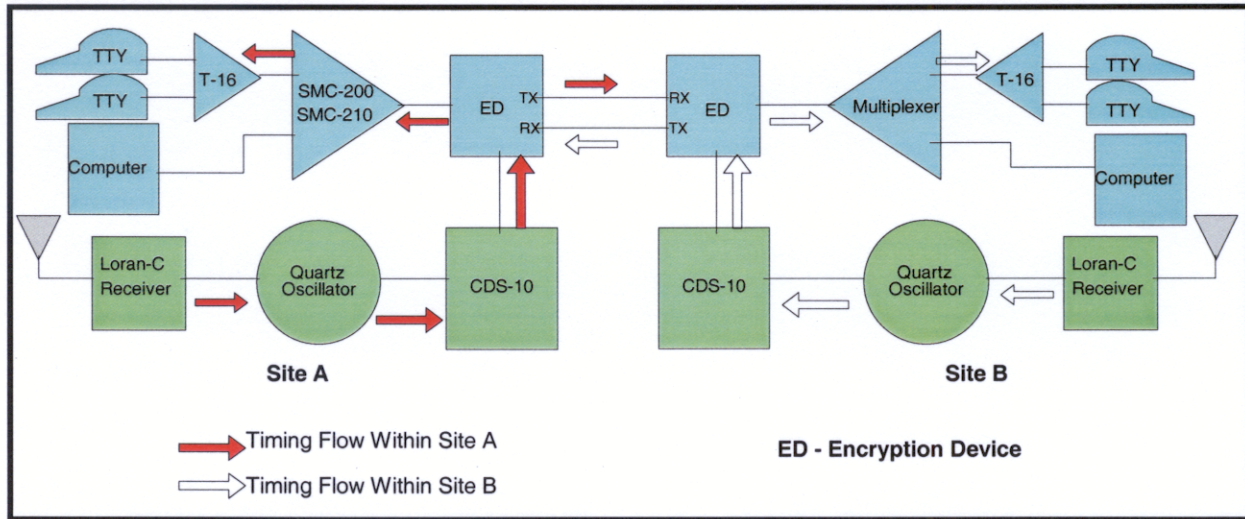

Figure 3: Typical Timing for Early Wideband Link (1980).

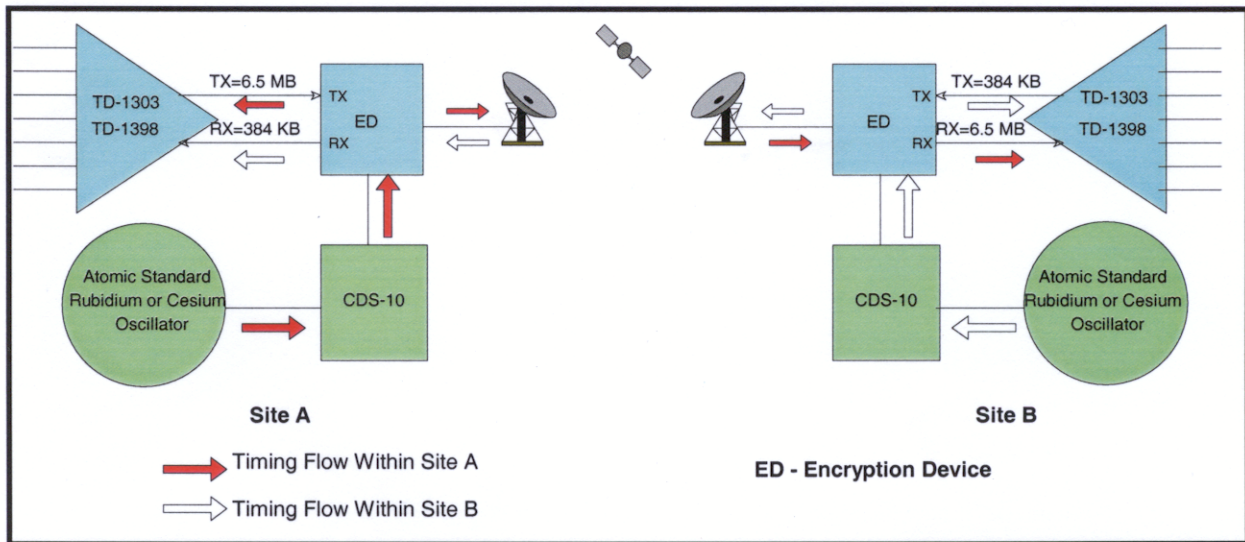

Figure 4: Typical Timing for Wideband Link (1988).

Next, *intelligent multiplexers* were introduced into the communication picture. This is where our communication facilities truly entered the networked stage of communications. The deployment of the intelligent multiplexers (produced by Timplex, N.E.T., *et al.*) required communication designers to become aware of timing in a network for the first time. This meant that the designers needed to ensure that the timing standards at all the nodes in their networks were consistent. This was not an easy task.

The solution was to deploy only atomic standards to our communication centers or to use recovered timing (from a site with an atomic standard) at stub sites. Figure 5 shows an example of this using a scaleable family of intelligent multiplexers.

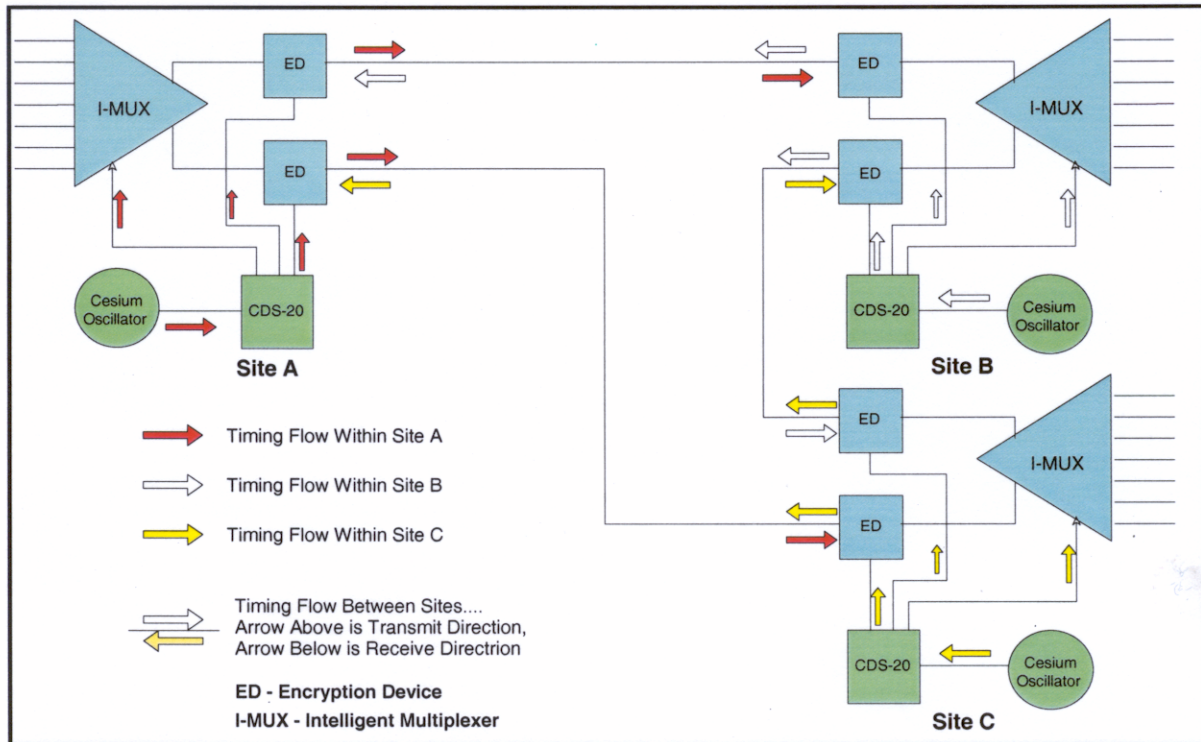

Figure 5: Typical Timing for Intelligent Multiplexers.

The Master Station Clock which fielded in the early 1990's consists of two major parts: (1) the reference oscillator, usually either a cesium-beam oscillator or a rubidium-cell oscillator; and (2) the rate generation and distribution equipment, typically comprised of equipment such as the Versitron's CDS-10 and CDS-20, the Fiberplex FDX-1401, SI-102, ACS-9100, and HP distribution amplifier devices.

The reference oscillator's function is to provide a stable and accurate base frequency for the Master Station Clock. For wideband sites, a cesium oscillator (HP-5061B or HP-5071A) is most commonly used. At most other sites, rubidium oscillators, which provide a Stratum II reference, are used.

The distribution portion of these Master Station Clocks usually consists of several distribution amplifiers to provide multiple copies of the primary reference output, which is fed to the clock rate generators, namely the Versitron CDS-10s and CDS-20s and the Fiberplex FDX-1401. Also, the primary reference is fed to the SI-102s and ACS-9100s, which are single rate synthesizers for rates above 2.048 MBps. The outputs of the rate generators provide the Station Clock for the encryption devices and external timing signals to the multiplexers. The rate generators also provide a clock signal to other devices in the communications center like *digital access cross-connects* (DAC), telephone switches, timing adapters, and CSU/DSUs. Figure 6 is an example of the pre-1997 Master Station Clock design.

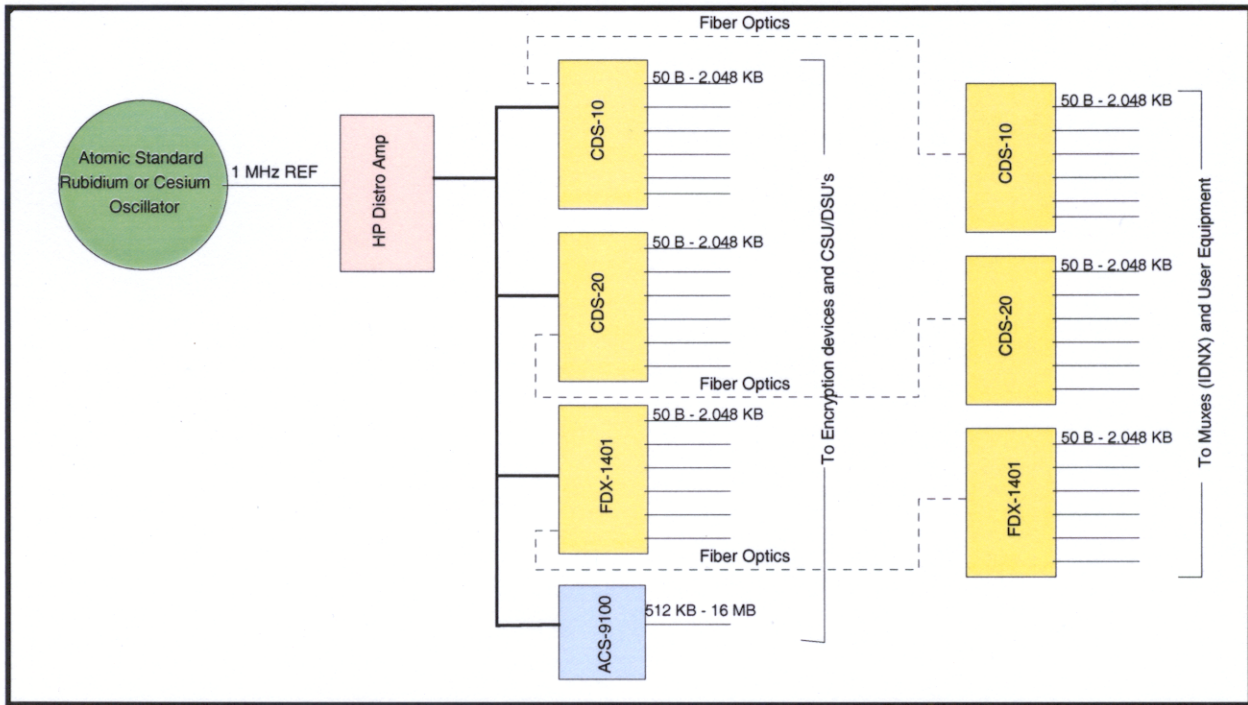

Figure 6: Master Station Clock (pre-1997).

## REQUIREMENTS FOR STABLE CLOCKS IN SECURE COMMUNICATIONS NETWORKS

To meet the goal for network syntonization, the designers of the network are required to provide a primary reference source with a frequency stability of better than  $1.0 \times 10^{-12}$  and a frequency accuracy of not less than  $1.0 \times 10^{-12}$ . This is consistent with the current best practices used by the telecommunication industry leaders in the timing of their *synchronous optical networks* (SONET). Also, to meet this requirement, the distribution of primary reference sources in the network shall be such that all nodal points can achieve syntonization to a primary reference source without creating a timing loop.

To meet the goal for network synchronization and time-of-day (TOD) signals, the use of Global Positioning System (GPS)-based primary sources is necessary. The current network requirement for TOD is 1 millisecond resolution with accuracy to Universal Coordinated Time (UTC) of 1 microsecond. At certain major locations in this network, which consists of both *local area networks* (LAN) and a *wide area network* (WAN), cesium will be used to provide extended holdover protection in the event of extended GPS outages (both localized and GPS system-wide).

When the telecommunication industry moved to a digital transmission network, the failure to maintain proper synchronization of the entire network caused loss of throughput capacity and reliability of service. If the clocks, which control the near and far ends of the communication paths, are not the same, a data slip occurs. This causes data (revenue) to be lost. Table 1 lists some of the major impacts caused by data slips.

Table 1: Detrimental Effects Caused by Clock Misalignment

Service Type	Detrimental Effect
Voice	Noise
FAX	Loss of picture content
Data	Re-transmission leading to reduced throughput
Video	Occurrence(s) of freeze frame(s)
Encryption	Re-transmission of encryption key and error extension

With the explosive growth in the worldwide telecommunication industry, standards are required to ensure that proper network synchronization could occur at the interface points between the networks of two or more carriers. The organizations, which serve this purpose, are the ITU-T and ANSI (technical subcommittee T1X1). These two organizations have defined requirements necessary for successful synchronization between digital networks. These standards include technical parameters required for the clocks used in telecommunication networks and several measures to test for compliance. This information is given in Table 2 for ITU-T and Table 3 for ANSI.

Table 2: ITU-T Clock Specifications

Stratum	Accuracy	Holdover Stability	MTIE (@ DS-1 rate)
G.811	$1.0 \times 10^{-11}$	N/A	72 days
G.812T	Unspecified	$1.5 \times 10^{-9}$	23 hours
G.812L	Unspecified	$3.0 \times 10^{-8}$	69 minutes
G.813 opt. 1	$2.0 \times 10^{-7}$	$6.0 \times 10^{-8}$	35 minutes
G.813 opt. 2	$2.0 \times 10^{-7}$	$5.5 \times 10^{-7}$	4 minutes

To provide the best of class in timing services, it is necessary to monitor the status and health of all the Master Clocks in the network. Another task is the real-time management of the clocks in the network. This will enable the operators of the enterprise to be proactive in responding to network timing problems and assist in providing the best possible level of service to the users of the enterprise network.

Table 3: ANSI T1 Standard Hierarchy of Clocks

Stratum	Accuracy	Holdover Stability	Technology	MTIE (@ DS-1 rate)
1	$1.0 \times 10^{-11}$	N/A	GPS, Cesium LORAN-C	72 days
2	$1.6 \times 10^{-8}$	$1.0 \times 10^{-10}$ per day	Rubidium	14 days
3E	$4.6 \times 10^{-6}$	$1.0 \times 10^{-8}$ per day	Quartz	17 hours
3	$4.6 \times 10^{-6}$	$3.7 \times 10^{-7}$ per day	Quartz	23 minutes
4E	$3.2 \times 10^{-5}$	Not required	Quartz	Undefined
4	$3.2 \times 10^{-5}$	Not required	Quartz	Undefined

## PROPOSED ARCHITECTURE

The current requirements for a Master Station Clock fall into two groups, namely: 1) frequency-based services to support the telecommunications type of equipment and circuits, and 2) time-of-day-based services to deliver UTC in various forms to TOD displays and to user automatic data processing (ADP) equipment for TOD synchronization within the entire enterprise.

The requirements for the Primary Reference Standard (PRS) are: (1) A minimum stability of Stratum I, preferably  $1.0 \times 10^{-12}$ . A minimum accuracy of Stratum I, but preferred is  $1.0 \times 10^{-12}$  or better. With the current commercially available technology, this level of stability can be achieved from either a good cesium standard (typical stability is  $1.0 \times 10^{-12}$  or better over period of 1 day) or through the use of P (Y) GPS receivers locked to the NAVSTAR GPS System ( $1.0 \times 10^{-13}$  typical using P (Y) receivers disciplining rubidium atomic standards).

Using either cesium or P (Y) GPS receivers as the PRS has its advantages and disadvantages. The main advantage in using cesium is that it is a primary atomic standard. Its main disadvantage is that the cesium tubes must be replaced on average every 5 to 7.5 years to maintain the proper operation of the standard. Also, since each cesium device has a unique ageing rate, the accuracy of each of the standards will slowly change with respect to each other. At some point in time this can cause data slips on wideband circuits. On the other hand, the main disadvantage of using a GPS-based PRS is the dependence on an outside reference system to lock the globally distributed communication system together. The risk of an extended outage on the GPS System is very small, but localized outages may occur. Typical would be lightning strikes on the antennas or inadvertent jamming caused by local RF transmitters. For these reasons rubidium oscillators are incorporated into the system to provide holdover for these types of outages. The main advantages of using the GPS-based system are longer life of the rubidium oscillators (estimated life 15 years) and the ability to lock the entire communication network to the same reference plane. This reference plane is directly traceable to the national reference located at the United States Naval Observatory (USNO).

The TOD requirements cannot be directly satisfied by atomic standards. Currently available cesium standards can provide a TOD output, but the information must be manually entered into the device. This process can introduce a variable TOD error between different geographic locations. The use of P (Y) GPS receivers to provide TOD signals eliminates this problem, since TOD data are provided by the NAVSTAR GPS constellation and is directly traceable to USNO's UTC (UTC-USNO).

The Master Station Clocks (Figure 7) will consist of the following components:

- 1) Primary reference source or derived reference
- 2) Distribution of the reference
- 3) Generation of the individual user rate clock signals
- 4) Distribution of the user rate clock signals.

The PRS selected for the Master Clocks shall be based on using a P (Y) Code GPS Receiver to discipline rubidium oscillators at each location where a Master Station Clock is installed. These systems shall consist of dual receivers and dual rubidium oscillators to provide for protection from a single point of failure. The rubidium oscillators are required to provide sufficient holdover in the event of a localized failure of both GPS receivers. This can occur if both GPS antennas are removed from operation by acts of nature or the site experiences some form of localized interference in the GPS bands.

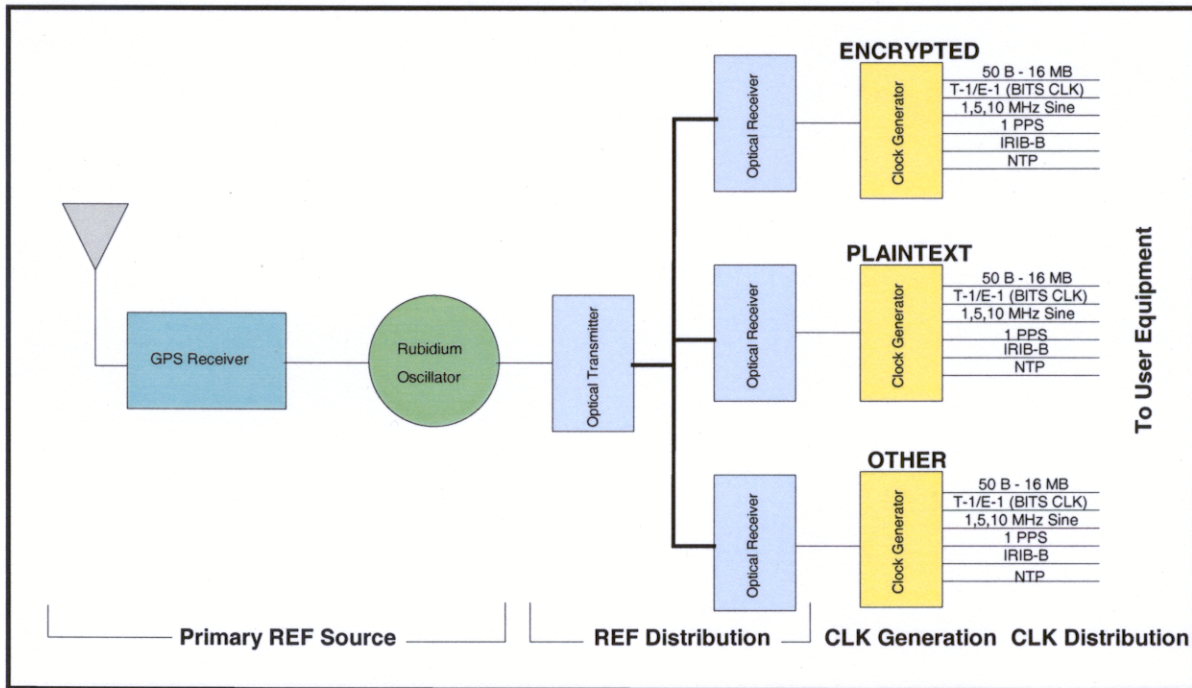

Figure 7: GPS-Based Master Station Clock.

To prevent network-wide timing failures during either a loss of the NAVSTAR GPS system or in the event of localized interference at major nodal sites in the global network, cesium oscillators will be added to select master clocks. The initial locations selected for cesium will be major switching nodes of the network. Additional locations that are part of the global enterprise will be added, if necessary, at a future date.

The distribution of the primary reference to the clock generation equipment shall be through the use of fiber optics to ensure that minimal noise is introduced into the system and that minimal signal loss is provided to the receiving devices.

The frequency generation section shall provide, as a minimum, the following types of user clock signals (*note*: not all signal types are required to be present at a given Master Clock installation):

- 5) Balanced NRZ/RS-442 signals at modem rates (50 BPs to 38.4 KBPs) and from 8 KBPs to 4.096 MBps in 8 KBps steps
- 2) Balanced AMI bi-polar "all-ones" signals at T-1 and/or E-1 rates, B8ZS, ESF
- 3) 1, 5, and 10 MHz at 1 volt rms into 50 ohms
- 4) 1 PPS (not used by communications equipment, but required by certain ADP users)
- 5) IRIG-B as a 1 KHz amplitude modulated carrier at 3 VPP into 600 ohms or via multimode fiber optics
- 6) NTP IAW RFC 1305.

All user clock signals shall be distributed to users by one or more of the following methods:

- 1) Twinax cable (124 ohms) or equivalent (balanced signals)

- 2) Low-loss 50-ohm coax cable (unbalanced signals)
- 3) Multimode fiber optics (IRIG-B and balanced signals)
- 4) Multi-pair O/A Shielded cable to media converter (NTP).

To ensure signal fidelity and maintain a high signal-to-noise (S/N), the copper cable should be kept to the shortest possible length, but should not exceed 500 feet.

## **TIMING OF TYPICAL TELECOMMUNICATIONS CIRCUITS**

### **POINT-TO-POINT SYNCHRONOUS CIRCUITS**

In general, low speed point-to-point circuits without multiplexers can take their timing reference from the DTE at one end of the circuit and recover the clock at the distant end. Although this is acceptable, if a Master Station Clock is available at either or both ends of the circuit path, the Master Station Clocks should be used.

Whenever a multiplexer is introduced into a point-to-point synchronous circuit, correct timing of the link is important to prevent timing slips. The stability of the clock source required for error-free operation of the circuit is dependent on the rate of the link. Hence, the use of the Master Station Clock is the preferred source of timing for these circuits.

The next level of complexity in point-to-point circuits is where a channel of one point-to-point multiplexed system is connected to another point-to-point multiplexed system. This is known as a pass-through or tandem circuit. In this example, all of the communication equipment must be timed from the Master Station Clocks at each site to prevent timing slips on the pass-through circuit.

### **INTELLIGENT MULTIPLEXER NETWORKS**

In this type of network, multiplexers can be connected to one or more other multiplexers at the same time. This creates the need for all of the intelligent multiplexers that comprise the network to be referenced to the same timing source. This can be accomplished by providing a timing reference to each node (multiplexer) in the network, which is in synchronization with all the other references. This will ensure that timing slips can be avoided in the network. It is crucial that timing loops must be avoided. Timing loops occur when a node is referenced through other nodes back to itself. This is clearly shown in Figure 8 when Node 2 is using the timing reference from Node 5. This is a timing (or clock) loop since Node 2 provides the reference to Node 3; Node 3 to Node 4; Node 4 to Node 5; but now Node 2 is getting its reference from Node 5 instead of Node 1 as it would under normal conditions.

This can be avoided by only using external-to-the-node timing sources (do not use recovered timing from an internodal trunk). In some cases it may not be possible to avoid using internodal trunk timing. When this occurs always select the clock references so that they are pointing from a higher-level node to a lower level node (see Figure 9).

In this network it is required that all node timing be traceable to, at a minimum, a Stratum I PRS. This can be accomplished by providing timing signals at each site to the external timing input or reference of each intelligent multiplexer and each encryption device and each CSU/DSU that is capable of accepting this timing reference. The reference to the master station-timing source can be a PRS or a derived

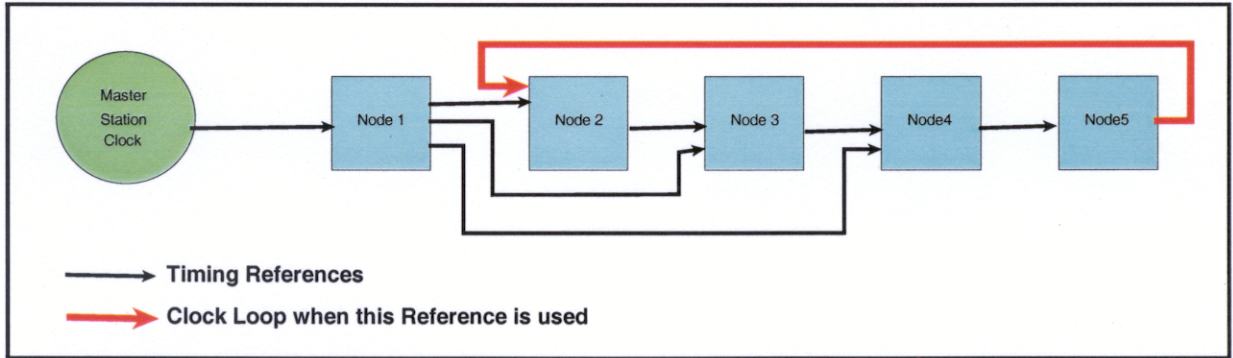

Figure 8: How Using Internodal Trunks Can Create a Timing Loop for Clock References.

reference source, as long as the derived reference source is phase locked to a Stratum I PRS without a clock loop.

For a given family of intelligent multiplexers, the rate of the external clock shall be uniform throughout the entire network. The rate for a specific network shall be a standard rate obtainable from the Master Clock Systems and in the range specified by the equipment manufacturer.

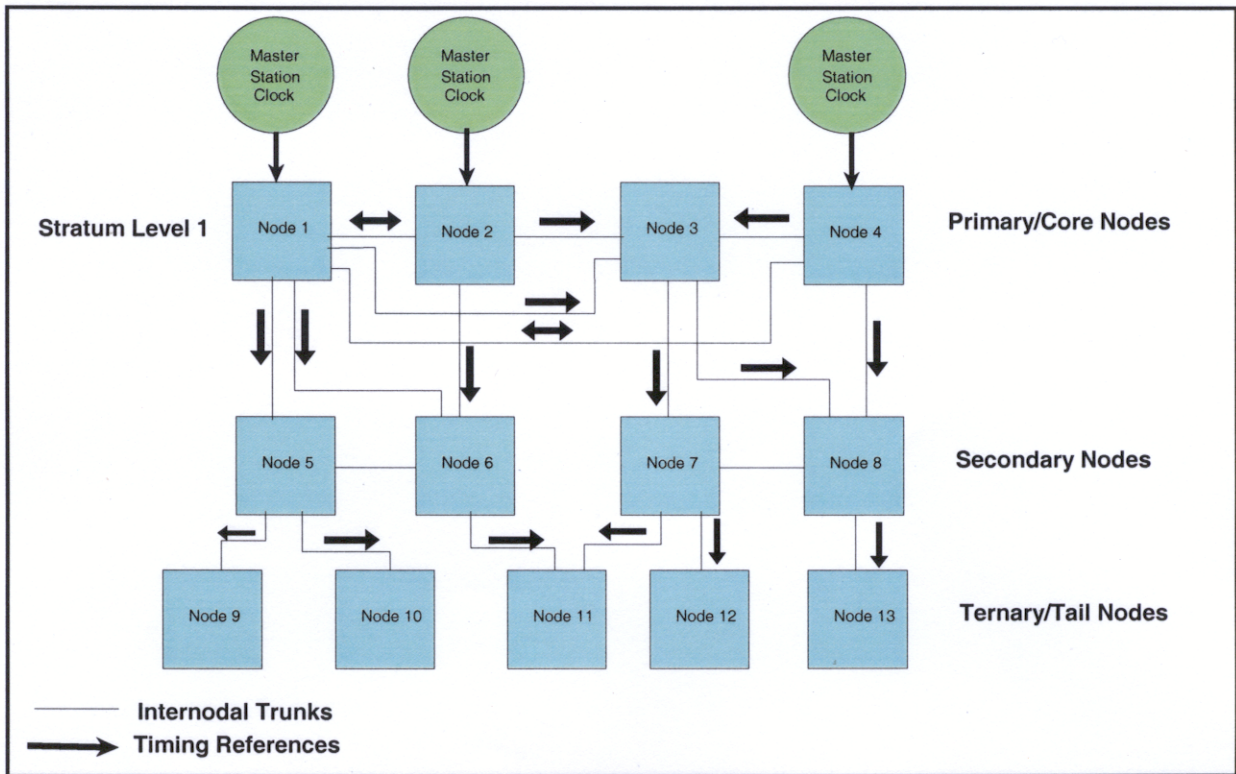

Figure 9: Using Internodal Trunks to Prevent Clock Loops.

## SONET NETWORKS

Clock stability and accuracy is extremely important in the proper design of all SONET networks because of the high data rates (an OC-3 is 155 MBps, while an OC-48 is 2.4 Gbps). It is also imperative that timing loops are avoided. The current industry practice is to use *building integrated timing systems* (BITS) to provide the timing signals to the SONET multiplexers. A BITS device is similar to a Master Station Clock, except that it usually only provides T-1 or E-1 timing references. At exchange offices (where switching gear is usually located), the BITS may also provide a 64 KHz *composite* clock used to synchronize all of the DS0 channels in the DS-1 links. Industry leaders also tightly control where and how PRSs are deployed throughout their networks. References provided to the local BITS from a neighboring nodal timing source are also controlled. The best networks do active timing management on a 24/7 basis. The PRSs used in these networks are a mixture of GPS-based systems and cesium oscillators.

A Linear SONET link is shown in Figure 10. It can be thought of as multiple single-span links connected back-to-back. The timing in this link becomes more complicated and requires, at a minimum, a Stratum I-based BITS or Master Station Clock at each end of the overall link. However, depending upon the number of spans in the link, it may be necessary to insert additional Stratum I PRSs at mid-link nodes. Care must also be taken to ensure that each node, which uses derived references, will be able to obtain a derived reference in the case of nodal failures. Again the most conservative posture would be to use a Stratum I-based BITS at each nodal site.

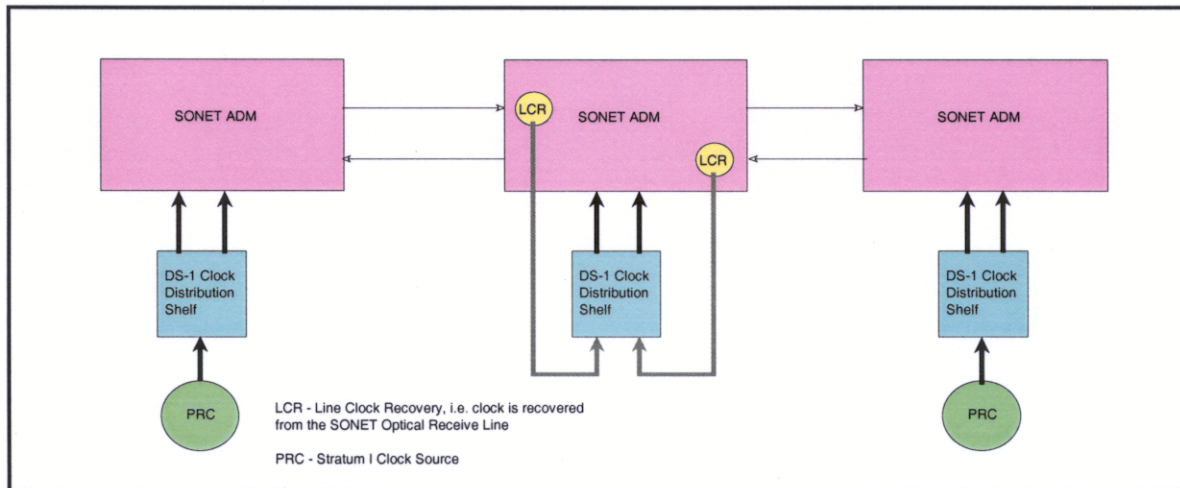

Figure 10: Timing in Multiple Linear SONET Links

The *counter-rotating ring* is the architecture of choice used by service providers today. It is shown in Figures 4-6. The major design issue for timing in this type of network is avoiding timing loops when the ring is switched into the protect mode of operation. This will happen when a fault occurs in the ring or preventative maintenance is being performed on a segment of the ring. Protection switching is not an issue when a Stratum I BITS or Master Station Clock is installed at each nodal point in the ring. In this case, all SONET multiplexers will receive an external timing signal from the BITS/Master Station Clock. When derived references are used, timing loops become a possible problem. The use of active timing

management also becomes mandatory in this type of network. Without active management, timing loops and other forms of timing instability are a real problem during equipment failures and/or outages.

The current trend for SONET providers is to use a flat timing architecture based on GPS in their networks. This eliminates many of the management problems when using a timing scheme as shown in Figure 11.

## ATM NETWORKS

In *asynchronous transfer mode* (ATM) networks, data traffic is usually contracted as non-real time *variable bit rate* (VBR) service, *available bit rate* (ABR) service, or *unspecified bit rate* (UBR) service. External timing of the ATM network is not required for these applications, since retransmission of missing or erred data cells can occur without impacting the users' applications. An assumption is that the users' application layer programs can detect data problems and request retransmission of the faulty ATM cells. In contrast, voice and video applications have *constant bit rate* (CBR) or real-time (VBR) service contracts. These types of ATM services require limited cell delay and cell delay variation. In effect, these types of services are transmitting synchronous bit streams across the ATM fabric. However, in the cases of CBR and real-time VBR contracts, proper timing of the ATM network is mandatory to ensure that the receiving ATM switch can reconstruct the data cells into a synchronous bit stream to forward to the external user.

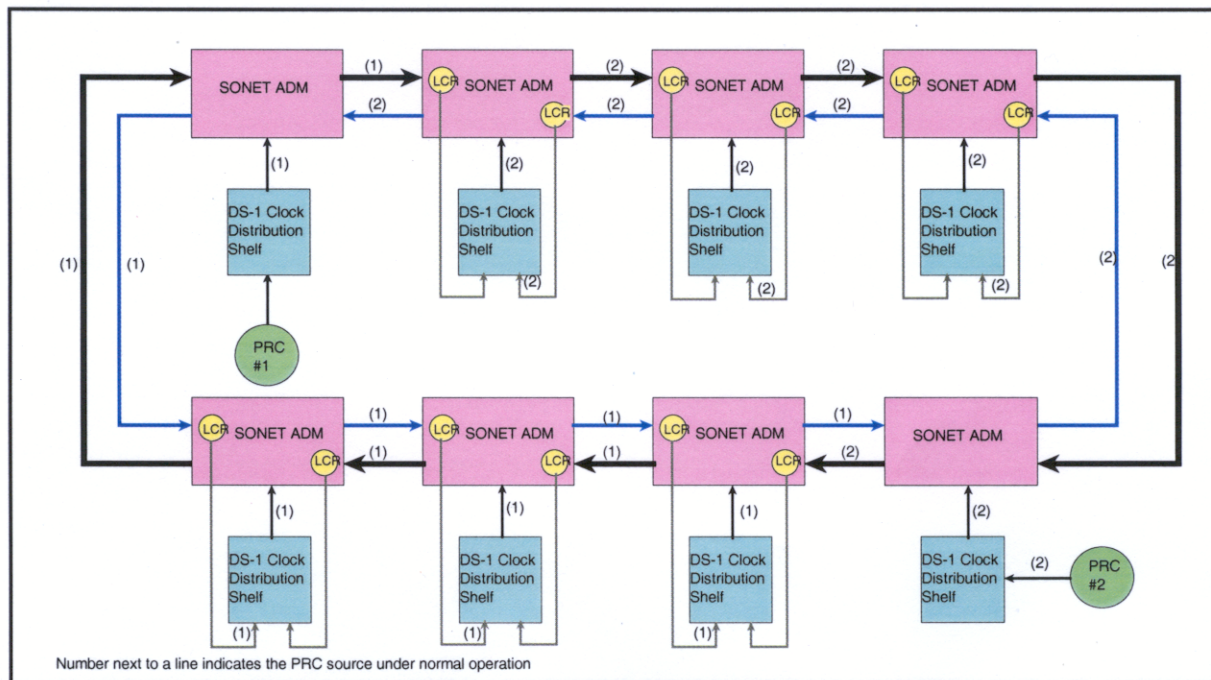

Figure 11: Timing in SONET Ring Using Recovered Optical Line Timing.

that the receiving ATM switch can reconstruct the data cells into a synchronous bit stream to forward to the external user.

At the CORE Node, at least two ATM switches shall receive a BITS timing reference signal (DSX-1, AMI Bi-Polar, B8ZS, ESF) directly from the Master Station Clock. The remaining CORE Node ATM switches will receive their timing reference from the timing module receive ports (see Figure 12). The timing reference(s) will then be distributed to the AREA and USER Node switches through *port recovered timing*. With port recovered timing, the incoming timing signal is sent through a phase-lock loop (PLL) to remove timing jitter.

## IP-BASED NETWORKS

IP-based networks (Ethernet, Token Ring, FDDI, etc.) normally operate in an asynchronous manner and do not require external timing. The exception to this general rule is when the serial side of a router is connected to a telecommunication system. If the system is a multiplexer, then the router is connected to a port on the multiplexer, and the port will provide the timing for the serial port on the router. Since the multiplexer is receiving its timing from the local Master Station Clock, this is adequate for this interface. When the serial port of the router is connected directly to an encryption device, the encryption device will provide the timing for the serial port. Again, in a properly designed communications link, the Master Station Clock will be providing timing to the encryption device.

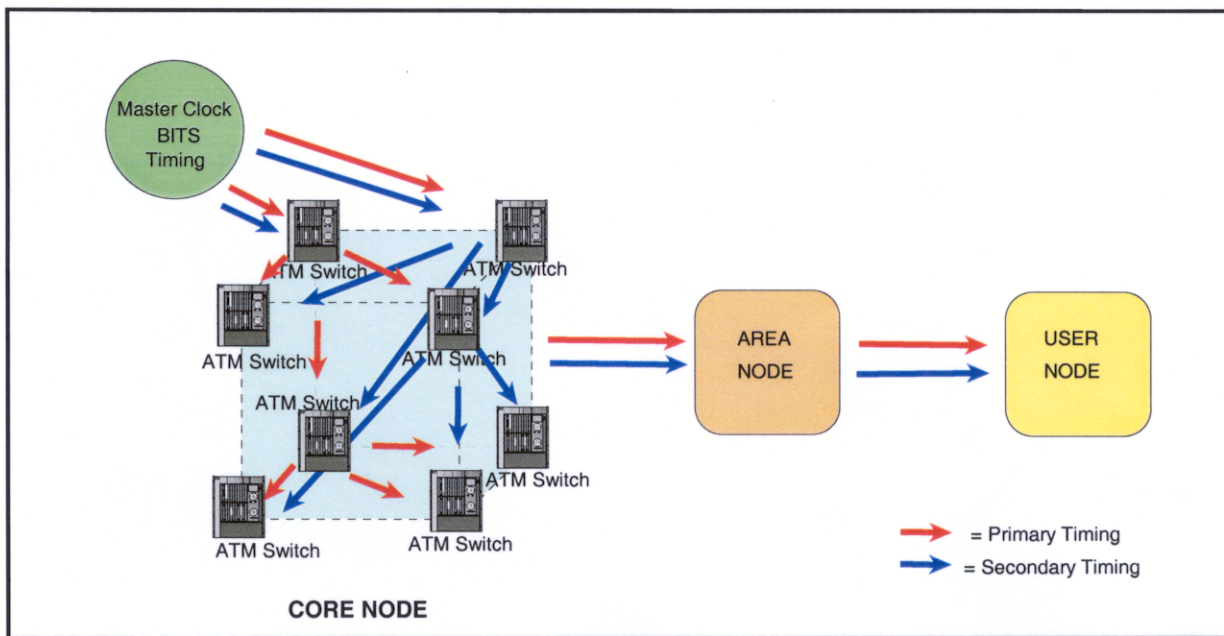

Figure 12: Typical Timing for an ATM Network.

With the advent of VoIP, the timing issues for IP services are expected to change. When the VoIP is computer to computer totally within the IP world, there should not be any requirement to inject external timing into the mix. However, when VoIP is used to place a call from a computer to a *public switched*

*telephone network* (PSTN) telephone, then the IP portion of the call must be timed by the PSTN to prevent timing induced errors, such as dropped calls, excessive noise, etc. This is very similar to the problems encountered with ATM CBR calls.

## **REFERENCES**

G. Shaton, 2001, "*Timing Architecture for a DoD Network*," Internal DoD Agency Document, Fort George G. Meade, Maryland, USA, April 2001.