

ETR
TR
71-5
c.2

THIS REPORT SUPERSEDES ETR-TR-68-5
DATED SEPTEMBER 1968
AS REVISED JANUARY 1971

LOAN COPY: RETURN TO
AFWL TECHNICAL LIBRARY
KIRTLAND AFB, N, M,

ETR-TR-71-5

AFETR INSTRUMENTATION HANDBOOK

DIRECTORATE OF RANGE ENGINEERING

MAINTENANCE MANAGEMENT
AND
CONTROL BRANCH

SEPTEMBER 1971



APPROVED FOR PUBLIC RELEASE
DISTRIBUTION UNLIMITED

DIRECTORATE OF RANGE ENGINEERING
INSTRUMENTATION DIVISION
AIR FORCE EASTERN TEST RANGE
AIR FORCE SYSTEMS COMMAND
PATRICK AIR FORCE BASE, FLORIDA



20080711 122

NOTICES

Copies of this report may be obtained from the Defense Documentation Center, Cameron Station, Alexandria, Virginia, 22314.

Approved for public release; Distribution Unlimited

Variation in format is permitted in the interest of economy in printing, and for rapid and easy reference.

When US Government drawings, specifications, or other data are used for any purpose other than a definitely related government procurement operation, the government thereby incurs no responsibility nor any obligation whatsoever, and the fact that the government may have formulated, furnished, or in any way supplied the said drawings, specifications, or other data is not to be regarded by implication or otherwise, as in any manner licensing the holder or any other person or corporation, or conveying any rights or permission to manufacture, use, or sell any patented invention that may in any way be related thereto.

AFETR
INSTRUMENTATION
HANDBOOK

DIRECTORATE OF RANGE ENGINEERING
INSTRUMENTATION DIVISION

MAINTENANCE MANAGEMENT
AND
CONTROL BRANCH

APPROVED FOR PUBLIC RELEASE

Distribution Unlimited

FOREWORD

THE BOOK IS INTENDED FOR GENERAL USE AND GUIDANCE. IT WILL BE USEFUL AS AN AID IN INDOCTRINATION AND FOR GENERAL REFERENCE AND WILL BE UPDATED PERIODICALLY TO RECORD CHANGES IN INSTRUMENTATION; HOWEVER, BECAUSE OF THE EXTENSIVE TIME REQUIRED FOR COMPILATION AND COORDINATION (SEVERAL MONTHS), IT CANNOT REFLECT DAY-TO-DAY CHANGES AND SHOULD NOT BE USED FOR IMMEDIATE "WORKING" INFORMATION.

ANY QUESTION REGARDING THIS DOCUMENT SHOULD BE DIRECTED TO THE CHIEF, MAINTENANCE MANAGEMENT AND CONTROL BRANCH (ENIM), PATRICK AIR FORCE BASE, FLORIDA, 32925. PROJECT OFFICER IS JOHN SAMILA.

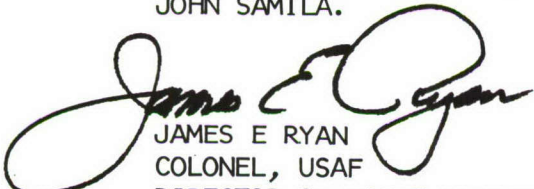

JAMES E RYAN
COLONEL, USAF
DIRECTOR OF RANGE ENGINEERING

ABSTRACT

This handbook describes ETR instrumentation resources used to obtain performance data and related information from missile and space flight tests.

The Data Acquisition Section covers instrumentation for observing flight performance, receiving internal data telemetered to the ground during flight, and measuring flight paths electronically. Various forms of fixed and tracking motion picture cameras, stationary and mobile tracking telescopes and infrared measurement systems provide optical and related coverage. Telemetry receiving stations collect and separate the internal data. Pulse radar trajectory measurement systems determine position and velocity during powered flight, orbital passes and re-entry. Underwater sound systems locate missile impacts.

The Support Systems Section includes descriptions of equipment used to sequence prelaunch operations, control Range instrumentation, and identify the times of events and data points. Information about equipment which formats data for use during flight, and equipment for sending voice and data messages between Range stations also appears in this section. Instrumentation for collecting weather data and for detecting and locating radio interference is described. Information about computers, data converters, photo readers and recorders used in postflight data processing is also included.

The Range Safety Section explains equipment used to monitor the Range area before launch, to observe deviations from the planned path during flight, and to terminate a flight before such deviations can endanger life or property. Applicable data acquisition instrumentation and support equipment are used with Range Safety equipment as a combined system during powered flight. Viewing devices at Cape Kennedy show flight performance and instantaneous predictions of impact point.

The Ships and Aircraft Section identifies the data acquisition and support instrumentation installed on various types of Range ships and aircraft.

The ETR Stations Section summarizes the on-site instrumentation resources and chief features of mainland and downrange bases.

CONTENTS

	<u>Page No</u>
FOREWORD	ii
ABSTRACT	iii
CONTENTS	v
ABBREVIATIONS AND SYMBOLS	xii
I. GENERAL RANGE INFORMATION	
Introduction	1
II. DATA ACQUISITION	
A. Pulse Radar	
Mod II Radar	8
AN/FPS-16 Radar	12
AN/FPQ-13 Radar	17
AN/FPQ-6 and AN/TPQ-18 Radars	20
Target Tracking Radar (TTR)	26
B. CW Systems	
Lorac	28
C. Optics	
Ballistic Cameras	31
Cinetheodolites	32
Fixed Metric Cameras	36
Medium and High Speed Cameras	38
70 mm Cameras	38
Intermediate Focal Length Trackers	39
MOTS	40
Igor	41
Roti	43
D. Impact Location - MILS	45
Target Array	46
BOA	47
SMILS	48

	<u>Page No</u>
E. Telemetry	51
Antennas	62
Receive/Record	66
Data Separation	71
Data Conversion	77
Data Processing	79
Data Correction (Data Correction System)	84
Data Display	85
Data Transmission - Real-Time Telemetry Data System (RTTDS)	90
III. SUPPORT SYSTEMS	
Communications	94
Undersea Cable	94
High Frequency Radio	96
Teletype	101
Communication Security (Com Sec) Equipment	103
VHF and UHF	103
Microwave	103
Interstation Communications	104
Audio Countdown and Aural Warning Systems	106
Audio Recorders	106
Closed Circuit Television	106
Range Communications Control Centers	107
Data Transmission	108
Timing	
Central Timing System (Downrange)	111
Timing Terminal Systems	114
Subcentral Timing Systems	114
Ship and Aircraft Timing Systems	114
VHF Timing Distribution System	114
KSC Timing System	117
Time Calibration	118
Time Terminal Unit	118
Ultra High Frequency (UHF)	119
Countdown Timing Systems	120
Range Count Control	122
Frequency Control and Analysis (Radio Frequency Management)	127
Range Control Center (RCC)	133

	<u>Page No.</u>
Real Time Data Handling	137
Cape Kennedy and Mainland Sites	137
RADDAC	148
Real Time Computer System (RTCS)	150
Post Flight Data Handling	160
Quick Look	160
Final Data Reduction	160
Procedures	161
Data Format	163
Data Reduction Equipment	163
Data Digitizing	163
Data Processing Computer	168
Data Display	170
Command/Control	179
Meteorological Instrumentation	187
AN/GMD-2 Rawin Set	187
AN/TMQ-5 Radiosonde Recorder	189
Meteorological Data Processor Model 3703	190
Windsonde	191
AN/AMT-12 Radiosonde	191
AN/FPS-77 Radar Meteorological Set	191
AN/GMQ-13A Cloud Height Set	192
ML-121 Ceiling Light Projector	192
AN/GMQ-11 and AN/GMQ-20 Wind Measuring Sets	192
ML-47/247 and 473 Theodolite	193
Double/Triple Theodolite System	193
ML-512 Mercurial Barometer	193
Aneroid Barometers ML-120, 331, and 332	193
ML-3D Barograph	193
ML-224/24 Psychrometer	193
Hygrothermograph	193
Aero-1927 Mercurial Barometer	194
Jimsphere Observations	194
Arcas Meteorological Rocket System	194
Arcasonde 1A	194
AN/DMQ-9	194
Loki Meteorological Rocket System	195
Data Processing	195
Weather Information Network and Display (WIND) System	195
Super Loki Dartsonde	196
Sferics, Position, Azimuth, Rate, Spectrum Analyzer (SPARSA)	196
Viper Dart Rocket System	196

	<u>Page No</u>
Range Photography	199
Metric	199
Engineering Sequential	199
Documentary	199
Pad Coverage	199
Motion Picture Processing	200
Processing Equipment	200
Printing Equipment	201
Still Photography Processing	203
IV. RANGE SAFETY	204
Range Safety	
V. SHIPS AND AIRCRAFT	211
Ships	211
USNS Redstone T-AGM-20	211
C4-S-A1 Ships: USNS Gen H H Arnold	
T-AGM-9, and USNS Gen Hoyt S Vandenberg	
T-AGM-10	211
Aircraft	240
ARIA	241
AACS	252
TRAP	262
VI. ETR STATIONS	
ETR Stations	263
Florida Annexes	264
Cape Kennedy Air Force Station (CKAFS)	266
Grand Bahama Island	268
Eleuthera	271
Grand Turk	272
Antigua	273
Ascension	275
Pretoria, Republic of South Africa	277
Bermuda	277A

LIST OF ILLUSTRATIONS

<u>Figure</u>		<u>Page No</u>
1	Typical Cinetheodolite Coverage	2
2	Igor-Roti Coverage	3
3	Uprange Electronic Instrumentation Coverage	4
4	Typical Telemetry Coverage	5
5	Terminal Phase Instrumentation	6
6	Radio Frequency Band Allocation	7
7	Mod II Data Equipment	11
8	Ascension AN/FPS-16 Data Handling	16
9	Mipir On-Cable Site Data Flow	24
10	Error Contours for ETR Lorac Network A	29
11	Error Contours for ETR Lorac Network B	29
12	CZR Camera System	37
13	ETR MILS Locations	45
14	MILS Data Handling	47
15	AFETR Telemetry System	52
16	Typical TDM Waveforms	53
17	AFETR Telemetry System Communications	55
18	Typical Downrange Station System Block Diagram	58
19	Tel 4 Systems Block Diagram	59
20	RTTDS Block Diagram	91
21	Undersea Cable System	95
22	Underwater Cable System Bandwidth	97
23	Bandwidth Allocation - Cape to Eleuthera (W.E. Cable)	98
24	AFETR HF Radio System	100
25	ETR Teletype Data Network	102
26	ETR Timing System - Cape Kennedy Timing System	109
27	ETR Timing System-Downrange Timing (Typical)	110
28	Timing Codes, IRIG Formats A, B, and C	112
29	Timing Codes, IRIG Formats D and E	113
30	ETR Firing System	125
31	FCA Facility Sites	130
31A	Range Instrumentation Control System (RICS)	135
32	ETR Simplified Primary Tracking Data System	137A
33	Cape Kennedy and Mainland Target Acquisition Bus (Simplified)	137B
34	GBI Acquisition System	141
35	Grand Turk Acquisition System	142
36	Antigua Acquisition Systems	143
37	Pretoria Acquisition System	144
38	Real Time Computer System	152
39	Input Interface Logic Block Diagram	154
40	Output Subsystem Block Diagram	156

<u>Figure</u>		<u>Page No</u>
41	Control Group Block Diagram	158
42	Expanded Data Reduction Conversion Equipment	164
43	Telemetry and Doppler Automatic Reduction Equipment (TARE)	166
44	MILS Signal Analyzer System	169
45	Typical Command/Control Station	181
46	Data Conversion Subsystem	183
47	AN/GMD-2 Rawinsonde System	188
48	Standard Motion Picture Products	202
49	Cape Kennedy Television System	208
50	AACS System	253
51	Timing Subsystem Block Diagram	255
52	DME Subsystem	260
53	AACS Mission Support Geometry	261
54	Florida Annexes	265
55	Cape Kennedy Air Force Station	267
56	Grand Bahama Island	270
57	Antigua	274
58	Ascension	276

LIST OF TABLES

<u>Table</u>		<u>Page No</u>
I	Telemetry Equipment Distribution	60
II	Uprange Telemetry Channels (W.E. Cable)	98
III	Command/Control Station Locations and Capabilities	186
IV	ETR Observing Equipment	198
IVA	Navigation Equipment - ARIA	245
V	Telemetry Systems - ARIA	246
VI	Range Instrumentation Checkout- ARIA	248
VII	Data Pickup - ARIA	249
VIII	Timing Systems - ARIA	250
IX	Communications Systems	251
X	AACS Timing Equipment/Functions	254
XI	Bahama Cays Planning Information	269
XII	Summary of Range Instrumentation	278

ABBREVIATIONS AND SYMBOLS

<u>Symbol</u>	<u>Definition</u>	<u>Symbol</u>	<u>Definition</u>
A	Angstroms	ATSS	acquisition and tracking subsystem (Mistram)
ABTSS	airborne transponder sub-system	Atrax	Air Transportable Communications Complex
ac	alternating current	avg	average
ACSS	analog computer sub-system	avgas	aviation gasoline
A/D	analog to digital	az	azimuth
AEC	automatic exposure control	BCD	binary coded decimal
AFCS	Air Force Communications Service	BET	best estimate of trajectory
AFETR	Air Force Eastern Test Range	BOA	broad ocean area
AFSC	Air Force Systems Command	bps	bits per second
A/G	air-to-ground	C/C	command/control
AGC	automatic gain control	CDCE	central data conversion equipment
		CKAFS	Cape Kennedy Air Force Station (Sta 1)
		CLSS	communication link sub-system
AM	amplitude modulation	cm	centimeters
Arcas	all purpose rocket carrier for atmospheric soundings	CRT	cathode ray tube
ARIA	Apollo/Range instrumentation aircraft	CS & TC	channel switching and technical control
ARIS	Advanced Range instrumentation ship	cu	cubic
ASA	American Standards Association	CW	continuous wave
Asco	automatic sustainer cut-off	DAC	digital to analog converter
ASPS	Acoustic Ship Positioning System	Dare	Doppler automatic reduction equipment
AT	acquisition tracking	db	decibels (dbm when referenced to 1 milliwatt)
		DCS	Digital Command System

<u>Symbol</u>	<u>Definition</u>	<u>Symbol</u>	<u>Definition</u>
DDPSS	digital data processor subsystem	FRT	fine resolution tracking
deg	degrees	FSK	frequency shift keying
DMSS	data multiplex subsystem	ft	feet
DOD	Department of Defense	gal	gallons
DPDE	data playback and digitizing equipment	GBI	Grand Bahama Island
DPE	data processing equipment	GHz	gigahertz (10^9 hertz)
DR	data receiver	Gdop(s)	geometric dilution of precision
D/R	down range	GMT	Greenwich Mean Time (Zulu)
DRS	Digital Range Safety System	gph	gallons per hour
DSSB	data selector and storage buffer	HDDR	high density data receivers
DTRSS	data transmission/recording subsystem	HDDT	high density data transmitters
ECM	electronic countermeasures	HF	high frequency
el	elevation	hp	horsepower
Elsse	electronic sky screen equipment	hr	hour
ETR	(AF) Eastern Test Range	HRT	high resolution tracker
FCA	frequency control and analysis	Hz	hertz (one cycle per second)
FIM	field intensity measurements sites	IF	intermediate frequency
F. L.	focal length	Iflot	intermediate focal length tracker
FM	frequency modulation	Igor	intercept ground optical recorder
FME	flexure monitor equipment	IIP	instantaneous impact point
fph	frames per hour	in.	inches
fps	frames per second or feet per second	I/O	input/output
		ipm	inches per minute
		ips	inches per second
		IR	infrared

<u>Symbol</u>	<u>Definition</u>	<u>Symbol</u>	<u>Definition</u>
IRIG	Inter-Range Instrumentation Group	MHz	megahertz (10^6 hertz) (used instead of megacycle per second)
kb	kilobit(s)	mi	miles
kHz	kilohertz (10^3 hertz) (used instead of kilocycle per second)	Mils	Missile Impact Location System
kt	knots	MIMS	Mobile Infrared Measurement System
kilovolts	min.	minutes or minimum	
kva	kilovolt-amperes	Mipir	Missile Precision Instrumentation Radar System
kw	kilowatts	Mitoc	missile instrumentation technical operations communications system
Lams	Launch Acoustic Measuring System	mm	millimeters
lb	pounds	MOIS	Missile Operations Intercommunications System
LARS	Launch Area Recovery System	Mots	Mobile Optical Tracker System
LCP	left hand circular polarization	mph	miles per hour
LDDR	low density data receiver	msec	milliseconds
LDDT	low density data transmitter	MUX	multiplex
LHC	left hand circular (polarization)	μ f	microfarads
LO	local oscillator	μ sec	microseconds
LOA	length overall	μ v	microvolts
ma	milliamperes	mw	milliwatts
MAC	Military Airlift Command	NBA	VLF transmitting station
max	maximum	NEPD	net equivalent power density
mb	millibars	nm	nautical miles
MCC	Master Control Console	NRZ	nonreturn to zero
MCP	Military Construction Program	NRZL	nonreturn to zero level
megw	megawatt		
MG	motor-generator		

<u>Symbol</u>	<u>Definition</u>	<u>Symbol</u>	<u>Definition</u>
NRZM	nonreturn to zero mark	rcdr	recorder
PACM	pulse-amplitude code modulation	RCO	Range Control Officer
PAM	pulse-amplitude modulation	rcv	receive
Pams	Pad Abort Measuring System	rcvr	receiver
P/C	polar to Cartesian	RF	radio frequency
PCM	pulse-code modulation	RFA	radio frequency authorization
PDM	pulse-duration modulation	RH	relative humidity
PLICK	prelaunch instrumentation check computer program	RICS	Range Instrumentation Control System
PMSS	precision measuring subsystem (Mistram)	RIS	range instrumentation ship
PPC	present position display controller	rms	root mean square
pph	pulses per hour	Roti	recording optical tracking instrument
ppm	pulses per minute	rpm	revolutions per minute
pps	pulses per second	RS	Range Safety
PRF	pulse repetition frequency	RSO	Range Safety Officer
psi	pounds per square inch	rss	root sum square
PSK	phase shift keying	RTCS	Real Time Computer System
Racon	radio navigation beacon	RTTDS	Real Time Telemetry Data System
Raddac	radar acquisition data distribution and control subsystem	RVRPE	radar video recorder and playback equipment
RAE	range, azimuth, elevation	RZ	return to zero
RAET	range, azimuth, elevation, and time (data)	Sarah	sea air rescue and homing
RATAC	radar target acquisition	sec	seconds
RCC	Range Control Center	S/N	signal-to-noise ratio

<u>Symbol</u>	<u>Definition</u>	<u>Symbol</u>	<u>Definition</u>
SPAC	signal programmer and conditioner	WWV	National Bureau of Standards Time Station
sps	samples per second		
sq in.	square inch(es)	X, Y, Z	position coordinates in the Cartesian system
SR	stabilization receiver	xmtr	transmitter
SSB	single sideband	yd	yards
STARS	Surface-To-Air Recovery System	yr	years
Tare	telemetry automatic reduction equipment	ZI	Zone of Interior
TD	transducer		
TDM	time division multiplex		
Telcar	telemetry carrier		
temp	temperature		
Tops	Transistorized Operations Phone System		
TTP	target trajectory plotter		
TTR	target tracking radar		
TTY	teletype		
UHF	ultra high frequency		
v	volts		
vac	volts, alternating current		
vc	voice channel		
vco	voltage controlled oscillator		
vdc	volts, direct current		
vel	velocity		
VHF	very high frequency		
VLFF	very low frequency		
w	watts		
WL	wireline		
wpm	words per minute		

I

GENERAL RANGE INFORMATION

I N T R O D U C T I O N

The Air Force Eastern Test Range (AFETR) extends from the eastern United States mainland through the south Atlantic Ocean area eastward into the Indian Ocean. It includes all stations, sites, ocean areas, and air space necessary to conduct missile and space vehicle test and development. Administrative and management activities are largely concentrated at Patrick AFB, while actual missile launches and flight tests are conducted at Cape Kennedy Air Force Station (CKAFS) and over the downrange areas.

This book describes the major instrumentation systems now operating, or being installed, on the ETR. The equipment and operation of each system is discussed briefly, and its location and accuracies given. More detailed information is available from system handbooks and manufacturers' literature.

Requests for specific information about equipment or systems should be made to the Director of Range Engineering, Air Force Eastern Test Range, Patrick AFB, Florida.

When determining the ETR capability to support planned programs, two additional documents complement this handbook: the Yearly Accuracy Report, with quarterly revisions, and the Geodetic Coordinates Report with quarterly revisions. Requests for these reports should be directed to the Data Analysis Branch (DOHA), Director of Range Operations.

GENERAL RANGE INFORMATION

FIGURE 1. TYPICAL CINETHEODOLITE COVERAGE

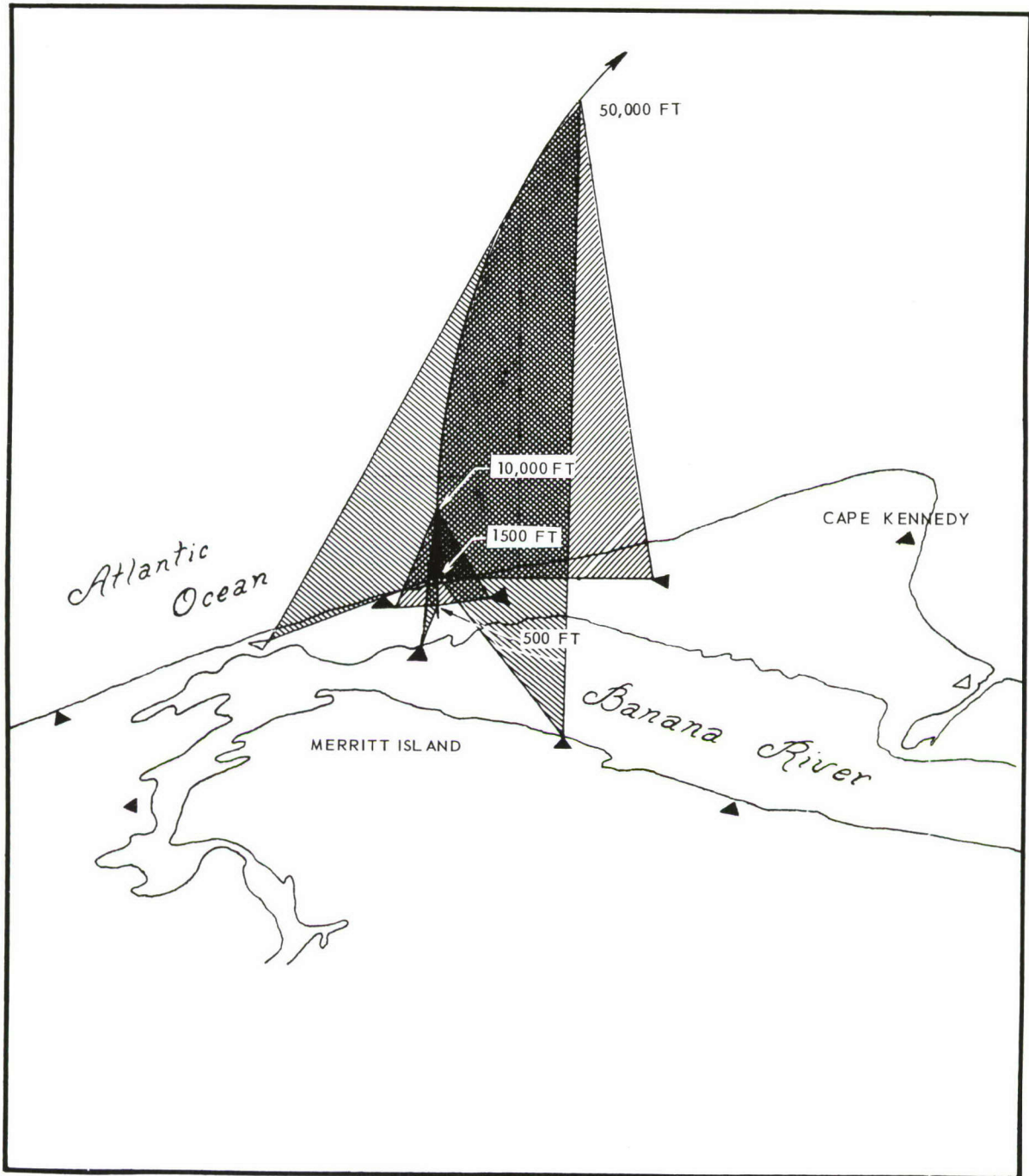

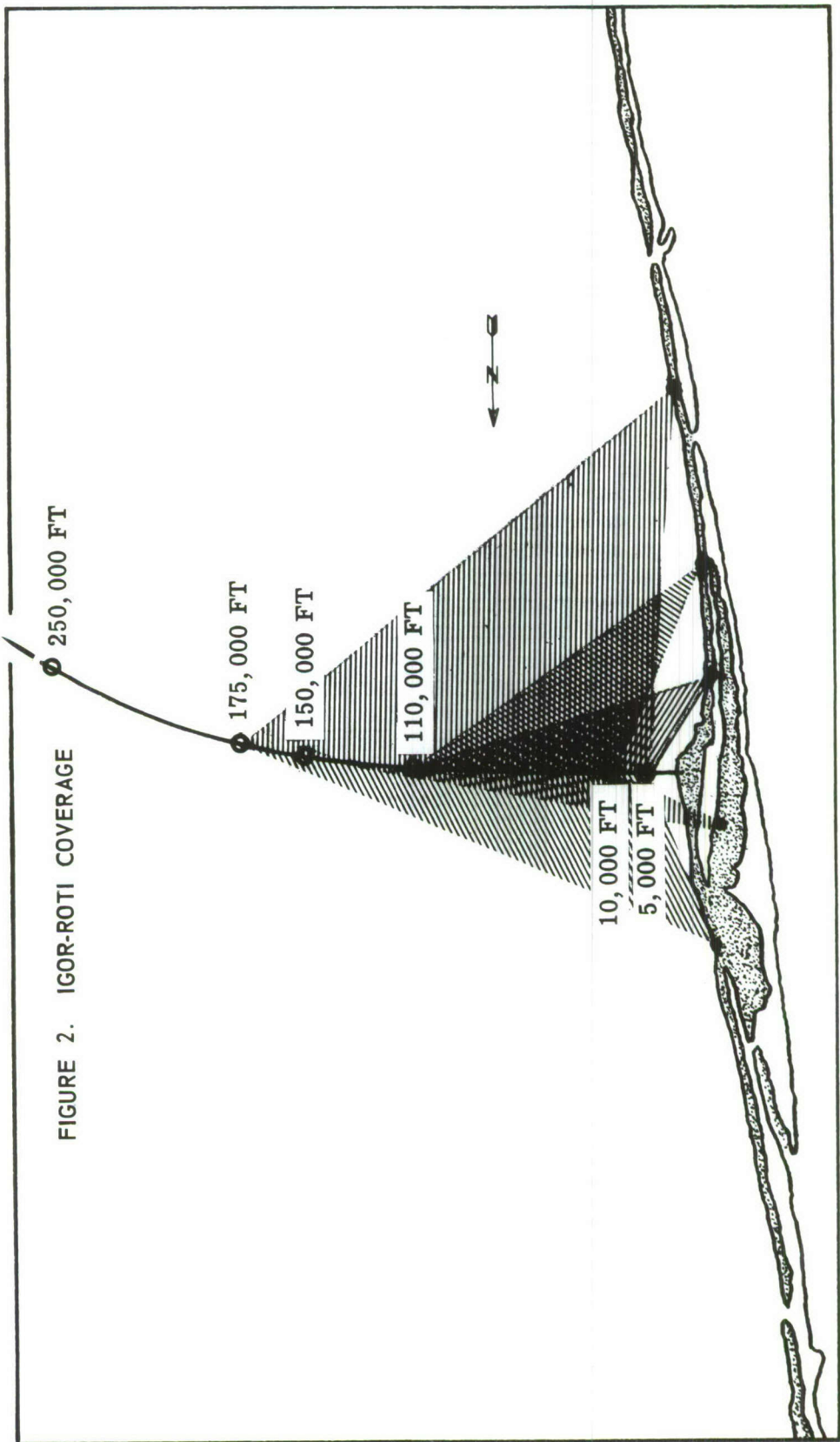
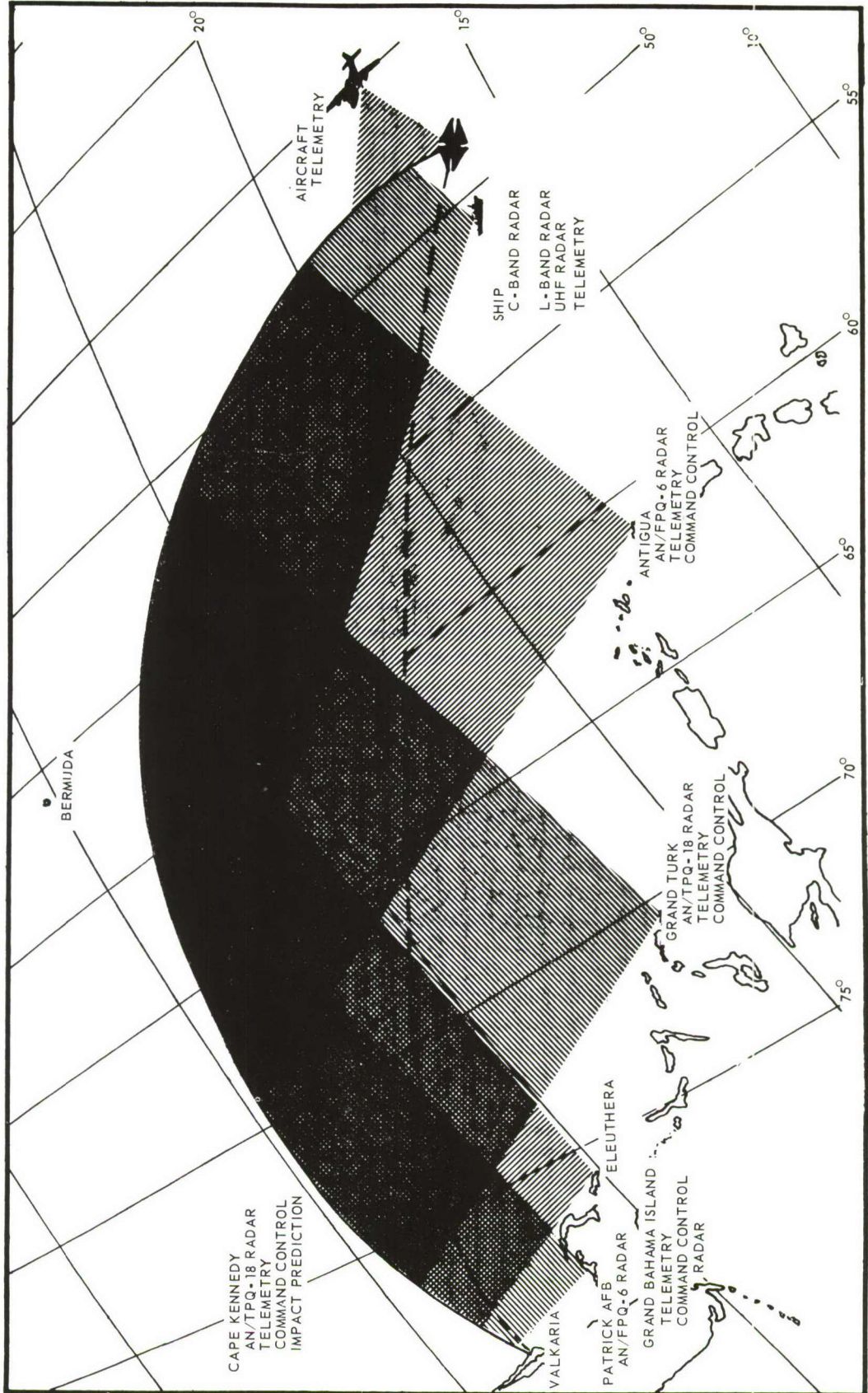

FIGURE 2. IGOR-ROTI COVERAGE

GENERAL RANGE INFORMATION

FIGURE 3. UPRANGE ELECTRONIC INSTRUMENTATION COVERAGE



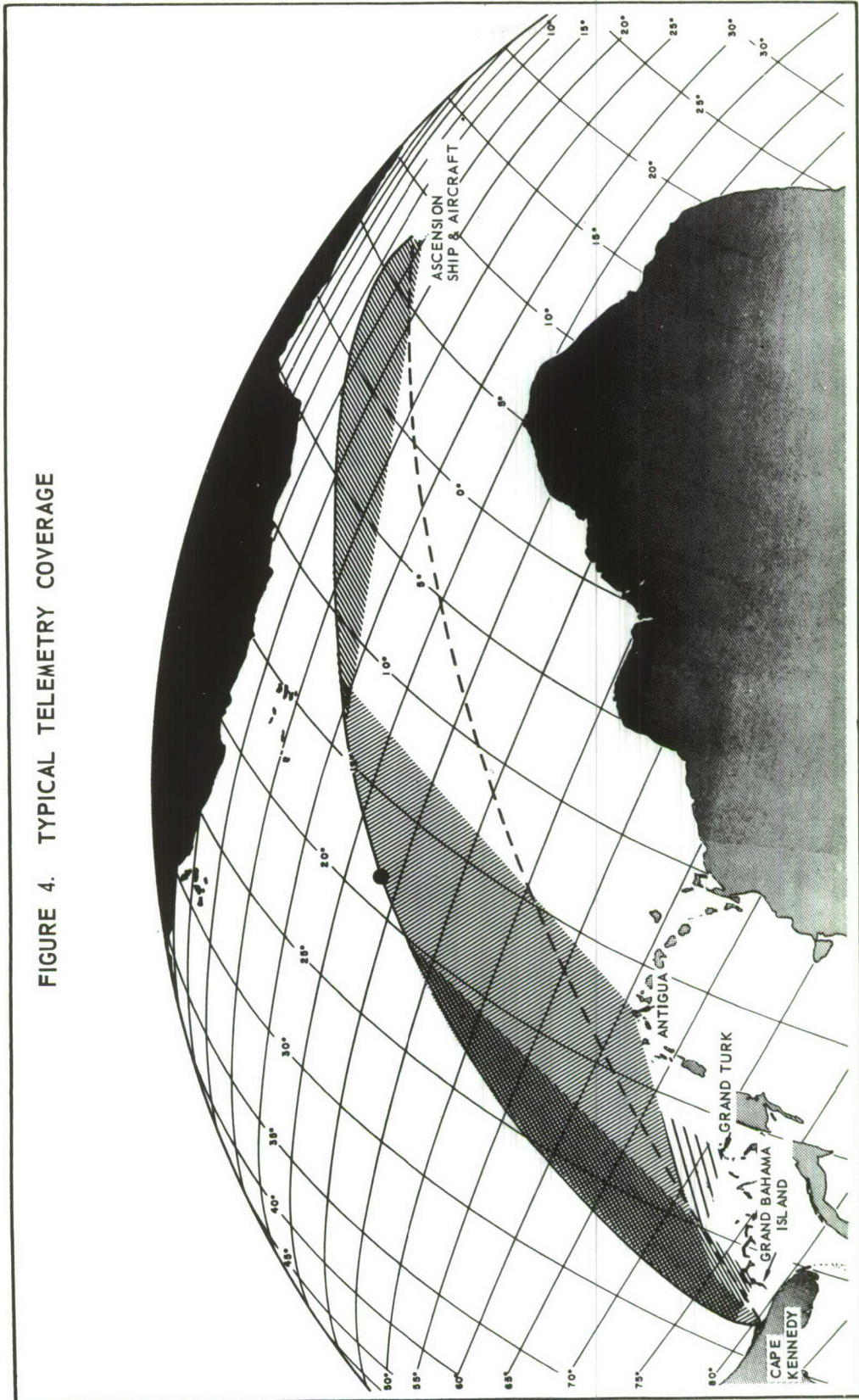
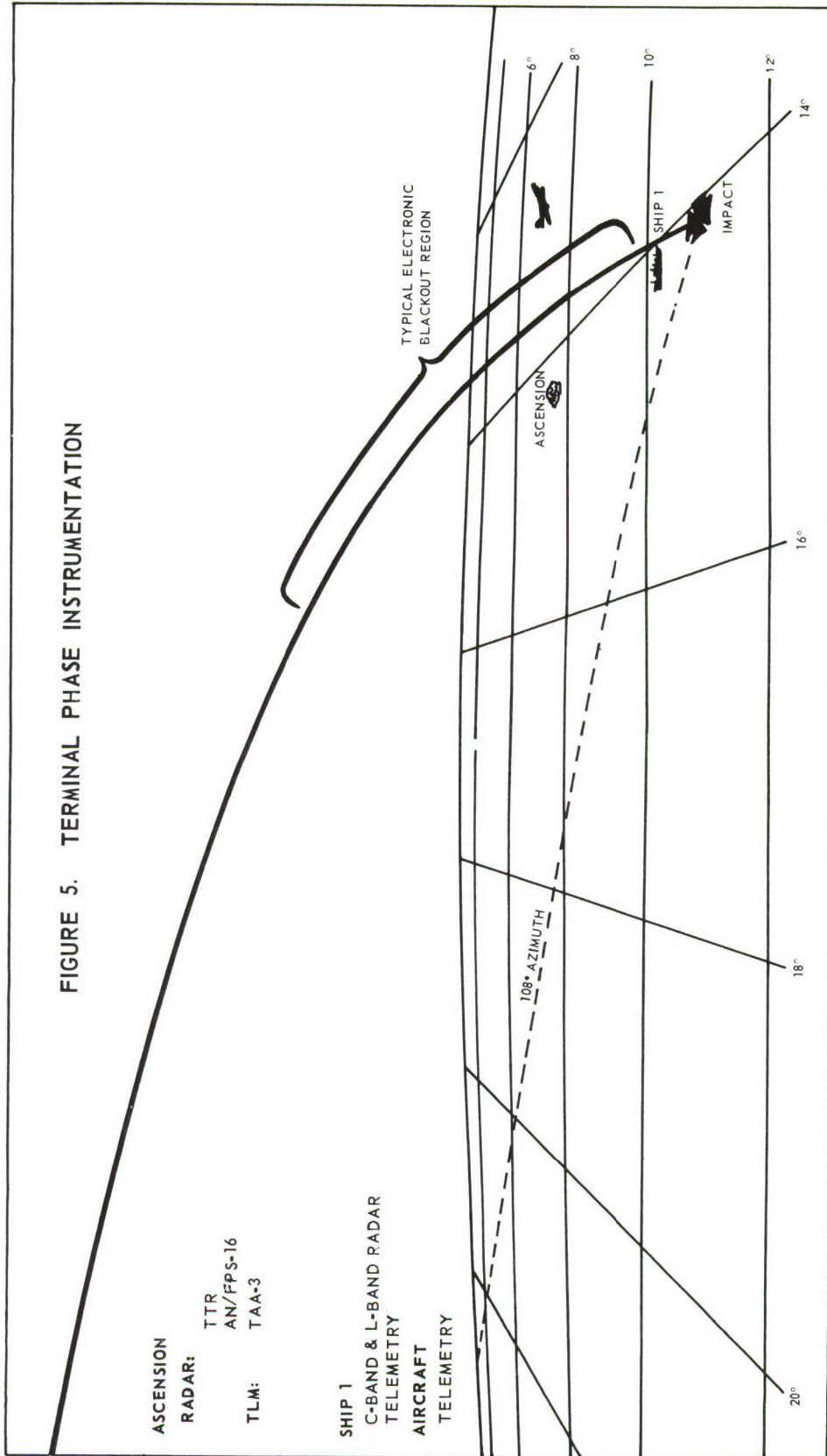

FIGURE 4. TYPICAL TELEMETRY COVERAGE

GENERAL RANGE INFORMATION



GENERAL RANGE INFORMATION

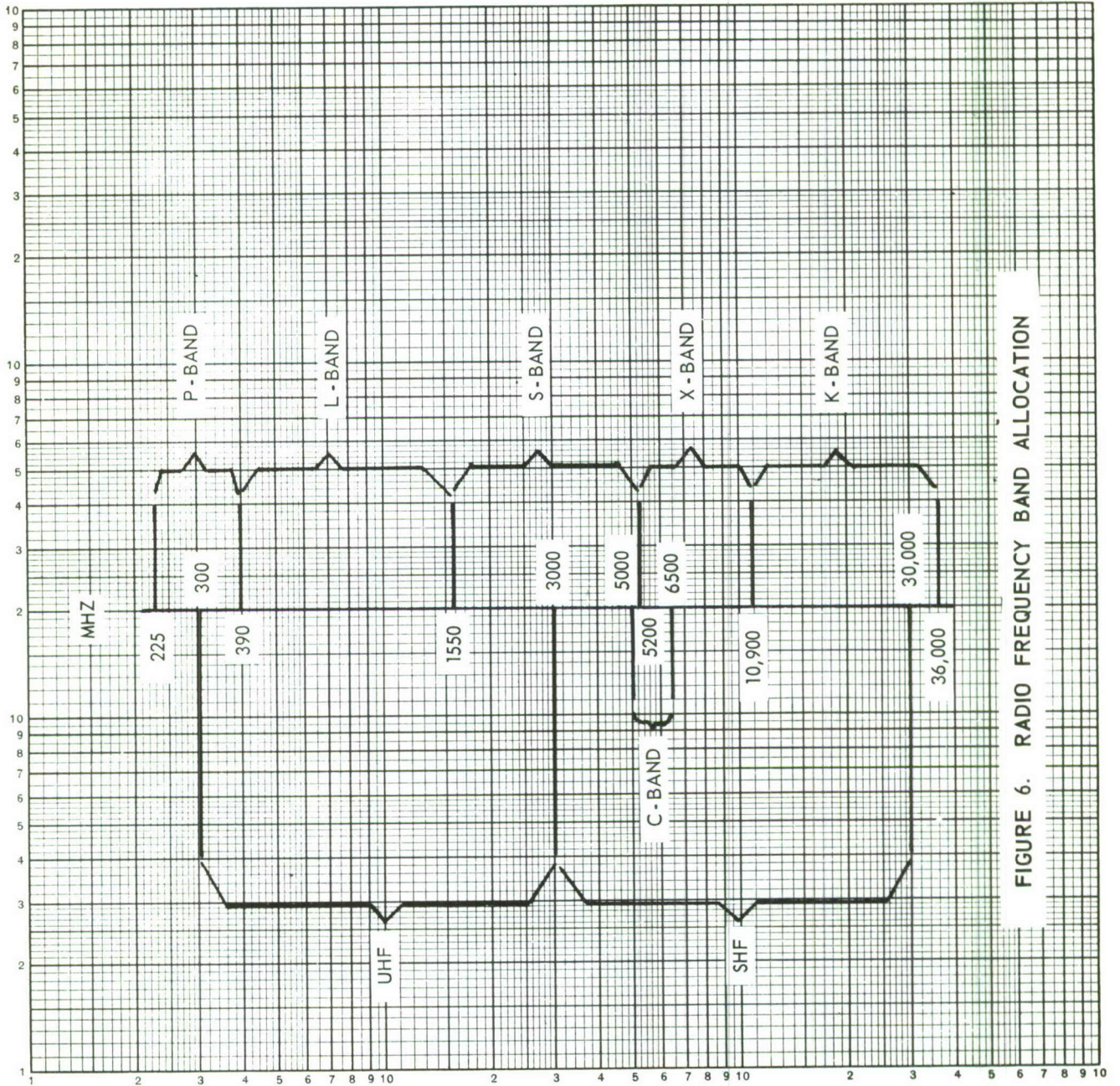

FIGURE 6. RADIO FREQUENCY BAND ALLOCATION

II

DATA ACQUISITION

MOD II RADAR

DESCRIPTION

The Mod II radar at ETR is a modified and rehabilitated World War II SCR-584 radar. The Mod II radar is an automatic angle and range tracking radar designed to provide (1) azimuth and elevation angle and range selsyn data, (2) slant range, altitude, ground range, and XY ground position potentiometer data, and (3) boresight cameras photographs and digital encoder data. All data is referenced to two calibration target poles, and a target of known range at every station. Mod II provides chiefly a network system to give tracking information for Range Safety and aircraft vectoring.

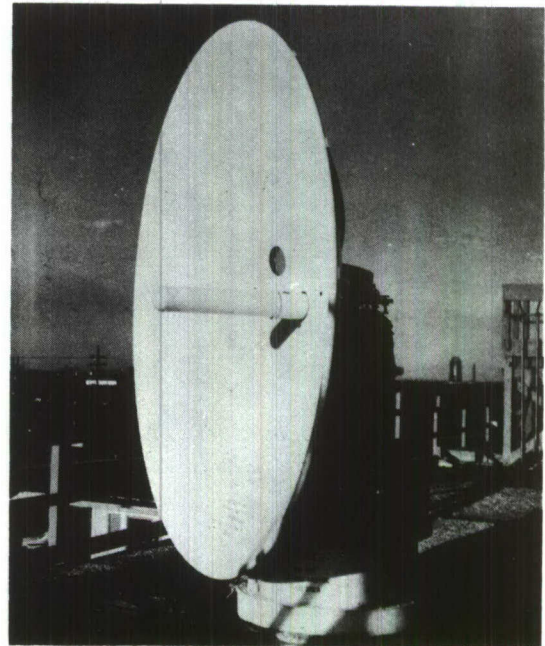

MOD II RADAR

Tracking with the aid of an airborne S-band beacon, Mod II can provide unambiguous radar line-of-sight coverage to a 400-nm slant range. The phasing system used for beacon operations permits reliable beacon tracking from two sites simultaneously. This radar can be used to skin track as well as beacon track.

LOCATION

<u>Station (Cape Kennedy)</u>	<u>Latitude</u>	<u>Longitude</u>	<u>Elevation (ft)</u>
Radar 1.5	28°30'	80°35'	51.48

PULSE RADAR
MOD II

TECHNICAL CHARACTERISTICS

Transmitter

Frequency: 2700 - 2900 MHz
Pulse width: 0.8 μ sec
PRF: 205 - 1707 pps
Peak power: 250 kw
Average power: 341.4 watts

Receiver

Frequency: 2650 - 2950 MHz
Bandwidth: 3 MHz
Noise figure: 13 db
Sensitivity: -96 dbm

Antenna

Size: 10-ft parabolic reflector
Type: Nutating scan with choice of 50% or 80% crossover
Nutates at approximately 1800 rpm (30 Hz)
Polarization: Vertical or horizontal
Gain: 37 db
Beamwidth: 2.5° unlobed measured at 1/2 power points. 3.8° with 80% crossover; 4.8° with 50% crossover.

Pedestal Angle Servos

	<u>Azimuth</u>	<u>Elevation</u>
Slew rate:	120°/sec	60°/sec
Limits:	360°	-1.5° to 90°
Tracking rate:	20°/sec	20°/sec

Range Tracking

Range: Unambiguous - 400 nm
Skin track: 40 nm on 1 m² target
at 0 db S/N

Tracking rate: 8,000 yd/sec
Minimum track-
able signal: 12 db

PULSE RADAR
MOD II

Accuracy

<u>Skin Track</u>	<u>Random Error</u>	<u>Systematic Error</u>
Azimuth	1.8-2 mil rms	1 mil rms
Elevation	1.8-2 mil rms	1 mil rms
Range	45 ft (60-90 nm)	100 ft
 <u>Beacon Track</u>		
Azimuth	1.2-2 mil rms	1 mil rms
Elevation	1.2-2 mil rms	1 mil rms
Range	45 ft (400 nm)	100 ft

Power Requirements

115 v $\pm 10\%$, 3 phase ungrounded delta, 12 kva

Acquisition Features

Target acquisition: Manual, acquisition bus, optical director, or bore-sight telescope

Target designation: Manual or automatic tracking mode

Range tracking: Manual, rate aided, and automatic

DATA

Two types of data are produced by the radar. Analog data is derived from potentiometers connected to the gear trains and is fed to a 484A computer which smooths the data and converts it to XYZ for plotting and to provide a target acquisition signal for other instruments. In addition, each radar has a 484B analog computer which accepts analog XYZ information and converts it to local range, azimuth, and elevation synchro data.

The digital data is derived from commutators and fed to a Giannini data recorder which punches it on a 6-channel paper tape. The data is punched in binary-coded decimal with five digits for azimuth and elevation and six digits for range at two-per-second rate with 17-digit range time and a station identifier.

PULSE RADAR

MOD II

DATA CHARACTERISTICS

Input: SE/SYN Data - Azimuth 1:1 and 36:1
Elevation 1:1 and 36:1

Output: Potentiometer data: Analog azimuth, elevation, and range
Commutator speeds: Azimuth and elevation 1:1 and 36:1
Range - 2,000:1, 50,000:1 and 1,000,000:1
Resolution - 1 yd/count and $0.005^\circ/\text{count}$

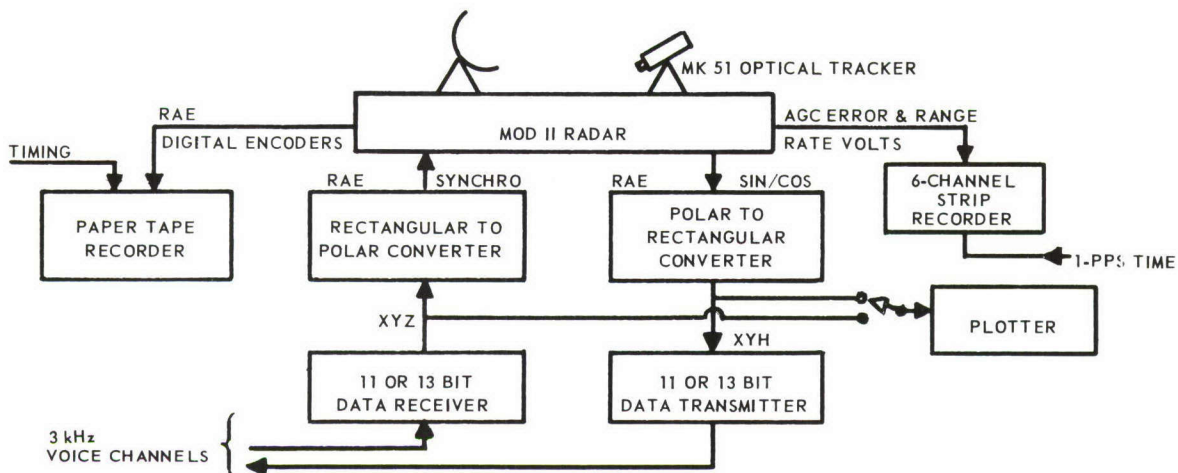

FIGURE 7. MOD II DATA EQUIPMENT

AN/FPS-16 RADAR

DESCRIPTION

The AN/FPS-16 is a high-precision, C-band, monopulse tracking radar designed specifically for missile tracking.

Transmitted power is relayed through microwave components to a four-horn feed which, with the reflector, produces a narrow beam. The transmitted signal may be either single-pulse, for skin track, or coded pulse, for beacon track. The return RF signal is received by the four-horn group and fed to an RF comparator which, by vectorial addition of energy received at selected pairs (horizontal and vertical), develops azimuth and elevation error signals representing the target's displacement from the beam centerline. The vectorial sum of the energy from all four horns furnishes a reference signal. The error signals are channeled to separate tracking sections, converted there to a 30 MHz IF signal, amplified and compared with the reference signal. The phase relationships determine the error direction and the amplitude indicates the error magnitude. These are detected, commutated, and used to control the antenna positioning servos.

An output of the reference channel is applied to the range tracking section to generate the voltage that positions the range data take-off equipment. Receiver channels are gated in range so that only signals for the target being tracked are supplied to the rest of the equipment. The range tracking section delivers slant range data to the digital section and to the console for presentation.

Data take-off in all three polar coordinates is in digital, synchro and potentiometer form. A Gray-to-binary conversion is made before data are transmitted and recorded. Range and angle digital data output is in straight binary form, with least significant digit first (20 bits, range and 17 bits, angle).

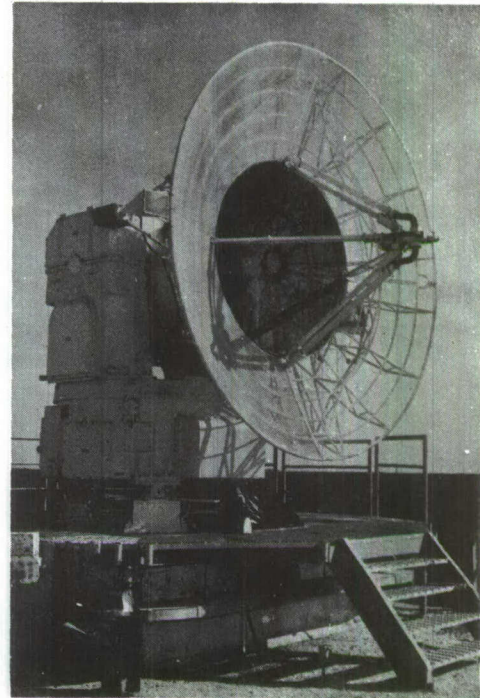

AN/FPS - 16 RADAR

PULSE RADAR

AN/FPS-16

LOCATION

<u>Radar No.</u>	<u>Station</u>	<u>Latitude</u>	<u>Longitude</u>	<u>Elevation (ft)</u>
1. 16	Cape Kennedy	28° 29'	80° 35'	44. 8
12. 16	Ascension	7° 57' (S)	14° 25'	302. 9

TECHNICAL CHARACTERISTICS

Transmitter:

Frequency: 5450 - 5825 MHz
Pulse widths: 0. 25, 0. 50, 1. 0 μ sec
PRF: 71, 80, 142, 160, 285, 320, 341, 366, 640 pps
Duty cycle: 0. 001
Peak power: 1 megawatt tunable-frequency
Pulse coding: Capable of 3 pulse codes
Power programming range: 30 db

Receiver

Frequency: 5450 - 5825 MHz
Bandwidths: 1. 8 MHz for 1 μ sec pulse width; 8 MHz for 0. 25 μ sec or 0. 50 μ sec pulse widths
Noise figure: 4 db
Sensitivity: -107 dbm for 2 MHz bandwidth, -101 dbm for 8 MHz bandwidth (-100 and -94 dbm)
Dynamic range with AGC: 80 db

Antenna

Size: 12 ft
Type: Parabolic reflector, newtonian focus with 4-horn monopulse feed
Polarization: Vertical, two-axis mount
Gain: 44 db
Beamwidth: 1. 2°

Pedestal Angle Servos

	<u>Azimuth</u>	<u>Elevation</u>
Slew rate	45°/sec	24°/sec
Limits	360°	-10° to 190°
Tracking rate	42°/sec	22.5°/sec
Tracking acceleration	31°/sec ²	31°/sec ²

Range Tracking

Range: Non-ambiguous -1,000 nm

Tracking rate: 12,000 yd/sec

Tracking acceleration: 2,000 yd/sec

Accuracy

Current radar accuracies are available in the AFETR Quarterly Accuracy Bulletin.

Power

120/208 v, 60 Hz, 4-wire grounded neutral

Radar load, 75 kva; air conditioning load, 75 kva

Acquisition Features

Range sweep: ±3000 yd

Angle sector scan: 10°, 20°, or 30° in azimuth or elevation at rates of 15, 30, or 60 sec/cycle, respectively

Angle circle scan: 0.9°, 2.3°, or 3.1° diameter at rates of 1, 2, or 4 sec/cycle, respectively

DATA

The flow of data through the AN/FPS-16 at Ascension is shown on page 25. The RAE data flows through line drivers into a raw data buffer. This buffer must be time shared between the AN/FPS-16 and the Ascension AN/TPQ-18 high density data (HDD) output. Thus, high density data can be transmitted from one or the other of these radars, but not both.

Three outputs are available from the raw data buffer. One goes to a magnetic tape recorder; a second goes to the Kineplex transmitter for RF transmission to the RTCS. The third data buffer output feeds the 1206 computer which can convert the data to 38-character TTY format (1 data point per 6 sec) or drive the Kineplex transmitter.

PULSE RADAR

AN/FPS-16

A second teletype output is available from the AN/FPS-16. The 10 pps AER data can feed a digital-to-TTY converter. This provides a 34-character message (1/6 sec) with time in octal code.

DATA CHARACTERISTICS

Input Data: Will slave to 60 Hz synchro data on azimuth, elevation, and range; or azimuth and range; or azimuth and elevation.

Outputs: Digital Data Output: Readout rate up to 100 samples/sec.

	<u>Azimuth</u>	<u>Elevation</u>	<u>Range</u>
Granularity	0.0488 mils	0.0488 mils	1 yd
Binary code	17 bits	17 bits	20 bits
Synchro data output:			
	<u>Azimuth</u>	<u>Elevation</u>	<u>Range</u>
Control transmitter	2 speed	2 speed	3 speed
Repeater	2 speed	2 speed	2 speed
Potentiometer data output			
	<u>Azimuth</u>	<u>Elevation</u>	<u>Range</u>
Voltage	Sine & cosine	Sine & cosine	Linear

PULSE RADAR
AN/FPS-16

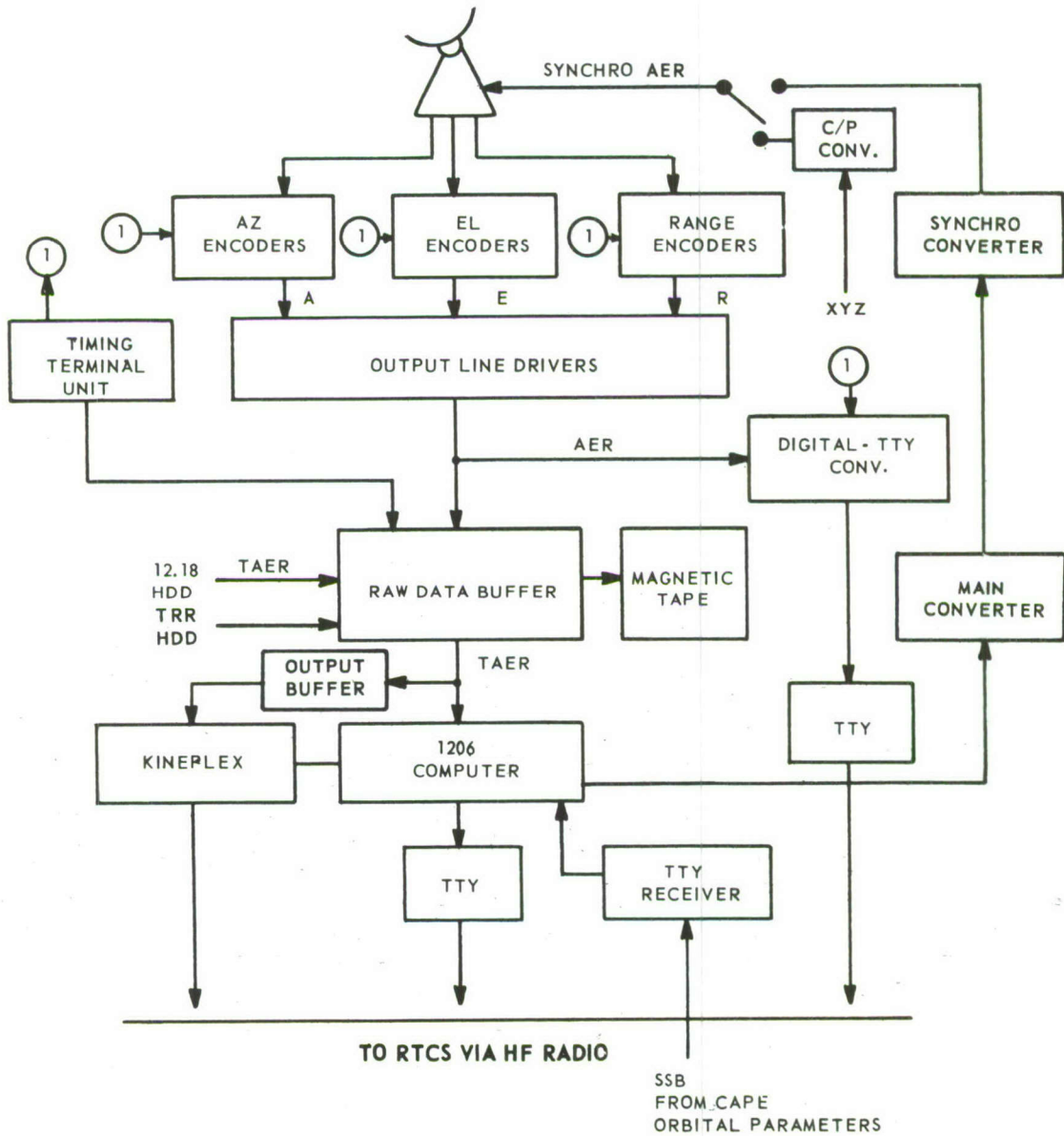

FIGURE 8 ASCENSION AN/FPS-16 DATA HANDLING

PULSE RADAR AN/FPQ-13

DESCRIPTION

The AN/FPQ-13 is a highly modified version of the AN/FPQ-16 radar for use as a satellite skin tracking radar in addition to launch support. It is located at Grand Bahama Island at latitude $26^{\circ}21'$, and an elevation of 45.5 ft.

Transmitted power is relayed through microwave components to a modified FPS-16 four-horn feed system to produce an RF beamwidth of 0.6 degrees. The transmitted signal may be either single-pulse, for skin track, or coded pulse, for beacon track. The return RF signal is received by the four-horn group and fed to an RF comparator which, by vectorial addition of energy received at selected pairs (horizontal and vertical), develops azimuth and elevation error signals representing the target's displacement from the beam centerline. The vectorial sum of the energy from all four horns furnishes a reference signal. The error signals are channeled to separate tracking sections, converted there to a 30-MHz IF signal, amplified, and compared with the reference signal. The phase relationships determine the error direction and the amplitude indicates the error magnitude. These are detected, commutated, and used to control the antenna positioning servos in the auto track mode.

An output of the reference channel is applied to the range tracking section to the AGC section to derive the AGC voltage for the receivers; to the range servo section to derive positioning voltages; and to the CFAR circuit for acquisition. Receiver channels are gated in range so that only signals for the target being tracked are supplied to the rest of the equipment. The range tracking section delivers slant range data to the digital section and to the console for presentation.

In the on-axis mode of track, all error and drive signals are computer processed to provide a smooth and highly accurate mode of track.

Raw data take-offs are digital only in range and both digital and synchro in angles. All output digital data is computer corrected.

TECHNICAL CHARACTERISTICS

Transmitter

Frequency: 5.4 to 5.9 GHz

Pulse widths: 1 μ sec, 5.0 μ sec

PRF: 160

Duty cycle: 0.0018

Peak power: 5 megawatt, tunable frequency (power add mode)
2.5 megawatt, single chain or when pulse coding

Pulse coding: Capable of two pulse codes. Two pre-set codes are selectable from the console. Code spacing can be varied from 3 μ sec to 9 μ sec.

**PULSE RADAR
AN/FPQ-13**

Power

120/208 vac, 60 Hz 4-wire grounded neutral

Radar and computer load: 75 kva

Air conditioning: 75 kva

Transmitter: 155 kva

Acquisition Features

Range and angle search patterns are computer controlled. Hit processor and CFAR circuits are provided for target identification.

Computer: Sigma 5, 24 K memory, 32-bit words 2.9-million byte disc memory, 9-channel tape, line printer, teletype I/O, typewriter I/O, paper tape I/O.

Data: Raw range and angle data is read from the encoders and range buffer at 100 pps. The data is computer corrected and outputted to the console displays and data user. The console displays are updated at either 1 or 10 pps. The output data information rate is 10 pps formatted in eight 30-bit words. The data output is compatible with a standard transmission rate of 2400 bits per sec. The output data is synchronized to ETR timing. Data synchronization and internal rates are derived from an IRIG A timing signal.

DATA CHARACTERISTICS

Input Data: 1-speed synchro data for azimuth and elevation, IRV, NORAD Message, XYZ low density data, look angles

Output Data: 2-speed synchro data for azimuth and elevation
EFGT 10 pps data or AERT 10 pps data
XYZ low density data
TTY 100 wpm B3 format
38 character format
IRV (Inter-range Vector)

The systems also has a 2400 bps HDD transmitter and receiver system for radar designation.

AN/FPQ-6 AND AN/TPQ-18 RADARS

DESCRIPTION

The AN/FPQ-6 fixed radar and its transportable version, the AN/TPQ-18, are C-band monopulse tracking radars designed and sited primarily to provide missile position and velocity in real time. They are able to beacon and skin track with high accuracy. Display of both skin and beacon information permits rapid switching to skin track if the transponder fails. Two AN/FPQ-6 and two AN/TPQ-18 radars are installed on the ETR. This family of radars is frequently referred to as Missile Precision Instrumentation Radar System (Mipir).

The radar features an ultrastable crystal oscillator that produces a signal which is multiplied to provide the RF signal. A power programmer allows adjustment of the transmitter output as a function of range (automatically or by operator control). A dummy load permits a radar silence mode. The output of the transmitter is connected to the feed horn through a polarizer which distributes the energy according to the desired polarization.

The antenna mount has hydrostatic azimuth bearings and precise ball bearings for elevation to reduce stiction and provide tracking smoothness. Skin and beacon returns may be displayed at the same time and either can be tracked.

Because of its extremely narrow beam width (0.4 deg), the AN/FPQ-6 must be assisted in acquiring a target. The acquisition system is made up of five parts: Multiple Range Gates, Auxtrack (or Auxiliary Angle Tracking) Unit, A Scope Displays, selectable antenna angle scans, and Tri-Pulse Coincident Gating.

The two AN/FPQ-6 radars and one of the two AN/TPQ-18 radars have been modified to increase the tracking range of the radar by 100% (12 dB). This modification includes a Dielguide/subreflector assembly, a single multimode feed horn, a comparator, a polarizer, a duplexer, two stages of parametric amplifiers cooled to 20 K, a refrigerator unit, 50 dB selectable attenuators, limiters, tunnel diode amplifiers, and mixer/preamplifiers, all located in the antenna feed cone assembly. A compressor for the cryogenic system is mounted on the pedestal azimuth turntable. Control panels, an IF phase shift chassis, a gain compensation chassis, and an automatic noise temperature meter are mounted in the electronics area. The Dielguide assembly increases antenna efficiency by reflecting RF energy that would be lost due to spillover past the edge of the subreflector.

PULSE RADAR
AN/FPQ-6 AND AN/TPQ-18

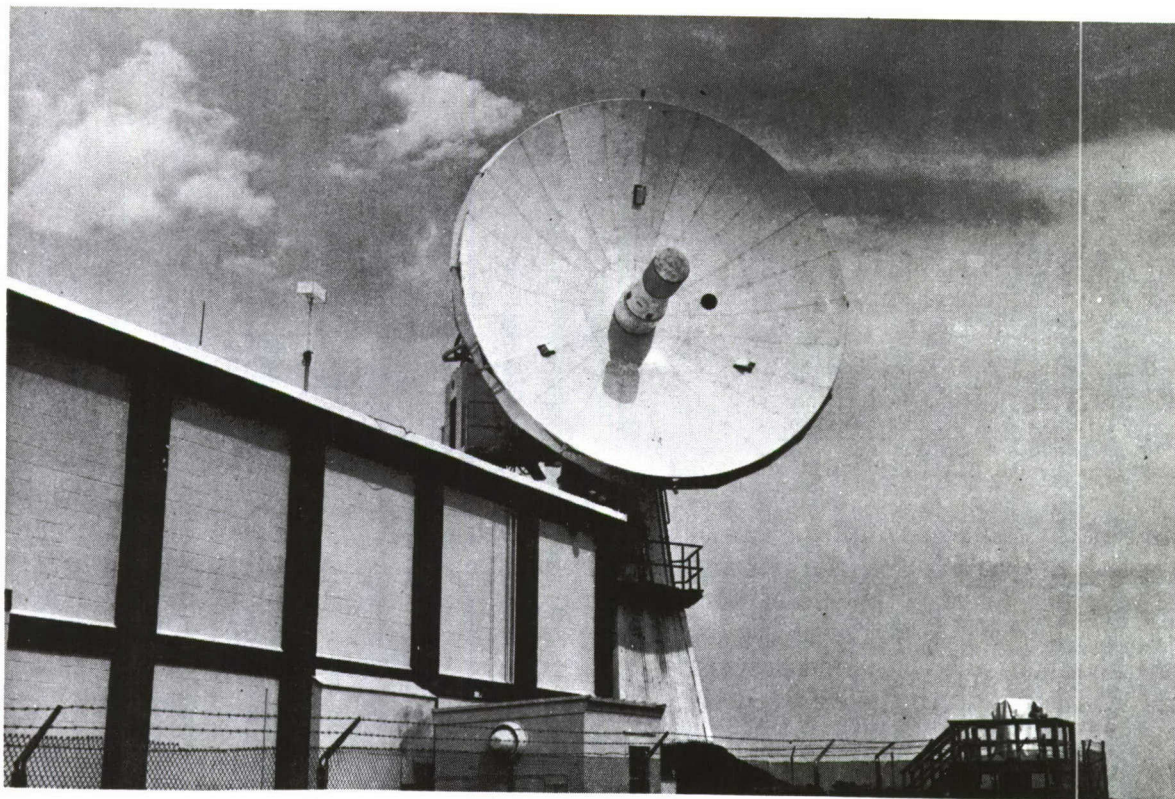

AN/FPQ-6 RADAR WITH 12 dB MOD ANTENNA

LOCATION	Latitude	Longitude	Elevation (ft) above MSL
<u>AN/FPQ-6</u>			
(91. 18) Antigua	17°09'	61°48'	138. 8
(0. 18) Patrick AFB	28°14'	80°36'	48. 9
<u>AN/TPQ-18</u>			
(19. 18) Merritt Island	28°25'	80°40'	36. 9
(7. 18) Grand Turk Island	21°28'	71°08'	118. 87

TECHNICAL CHARACTERISTICS

Transmitter

Frequency: 5400-5900 MHz - Tunable
 Frequency stability (synthesizer): 1 part in 10^8 per hour
 Fine tuning: ± 5 MHz about center frequency
 Pulse widths: 0. 25, 1. 0, 2. 4, 5. 0 μ sec
 PRF: Prime: 160, 640 pps
 Auxiliary: 142, 233, 285, 341, 366, 1280, 1707 pps
 Duty cycle: 0. 0018
 Peak power: 2. 8 megawatts
 Average power: 4. 8 kw
 Pulse coding: IRIG 106-59 capability
 Power programming range: 25 dB

Receiver:

Frequency: 5400-5900 MHz
Stability: ± 2 MHz
Bandwidths: 0.2 to 4.8 MHz
Noise figure: 3.5 dB (1.173 dB with a 12 dB Mod)
Sensitivity: -102 dBm at 4.8 MHz bandwidth (-112 dBm at 4.8 MHz BW with a 12 dB Mod)
 -111 dBm at 0.5 MHz bandwidth (-121 dBm at 0.5 MHz BW with a 12 dB Mod)
Dynamic range: 120 dB including 50 dB of programmed attenuation
 (155 dB including 50 dB of selectable attenuation with the 12 dB Mod)

Antenna

Size: 29 ft
Type: Paraboloid of revolution, 5-horn monopulse Cassegrainian feed
 (Single multimode monopulse horn and Dielguide Cassegrainian feed with a 12 dB Mod)
Polarization: Left hand circular and vertical linear.
Gain: 51 dB (53 dB with the 12 dB Mod)
Beamwidth: 0.4°

Pedestal Angle Servos

Slew rate
Limits
Tracking rate
Tracking acceleration

Azimuth

$28^\circ/\text{sec}$
 360°
 $28^\circ/\text{sec}$
 $20^\circ/\text{sec}^2$

Elevation

$28^\circ/\text{sec}$
 -2 to 182°
 $28^\circ/\text{sec}$
 $20^\circ/\text{sec}^2$

Range Tracking

Range: Unambiguous - 32,000 nmi
Slew rate: 240,000 yd/sec
Tracking rate: 20,000 yd/sec
Tracking acceleration: $20,000 \text{ yd}/\text{sec}^2$

Accuracy

Current radar accuracies are available in the AFETR Quarterly Accuracy Bulletin.

Power: 208v at 27 kva and 480 v at 98 kva

Acquisition Features

(a) Digital Detection and Acquisition System

Multiple Gate Array

Type: All electronic type II servo
Number of gates: 20
Length of each gate: $6.1 \mu\text{sec}$
Required designation accuracy: $\pm 10,000$ yd

PULSE RADAR
AN/FPQ-6 AND AN/TPQ-18

(b) Auxiliary Tracking System

Type: All electronic, type I servo
Acquisition S/N ratio: 10 dB or greater
Probability of detection: 99.5% with S/N of 10 dB and
 10^{-3} false alarm probability

(c) Video Integrator (Display Video Only)

Type: Recirculating delay line
S/N improvement: Up to 12 dB for targets with signal-to-noise ratios as low as 0 dB
Number of pulses integrated: Adjustable in 9 steps up to 100

(d) Antenna Scans: Spiral, raster, rectangular, and circular

(e) Tri-Pulse:

Type: Coincident Gating
Capability: Unambiguous range detection to PRE maximum
Transmit: Two 3-pulse groups at PRF of 20, 40 or 80
Receive: Pulses and groups are delayed, then AND gated

DATA

The data handling methods for these radars are essentially the same as those described for the AN/FPS-16 radars. The data handling equipment at Merritt Island, Patrick AFB, Grand Turk Island, and Antigua is for sites with hard wire communications to Cape Kennedy while that at Ascension Island is for off-cable sites.

The flow of data through the Mipir is shown in Figure 3. Range, azimuth, and elevation data is read into the 4101 computer (which is part of the Mipir) at 20 pps. The 4101 computer makes corrections for some known errors in the azimuth and elevation data and also performs any necessary formatting. Corrections are made for droop, non-orthogonality, pedestal mislevel, and encoder bias. Dynamic lag, transit time, and retraction are optional corrections which may be made in the 4101 computer. Adjustments are made to Range data depending on the optional corrections selected by the 4101 computer.

Outputs are available through line drivers at 20 pps or through the Flexowriter at 1 per 6 sec or 1 per 10 sec.

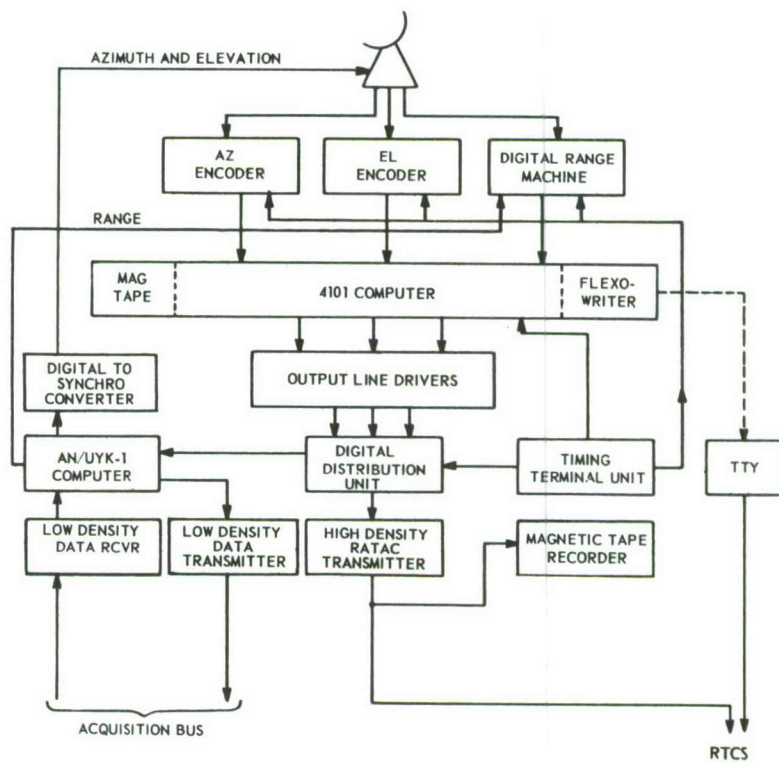

FIGURE 9 MIPIR ON-CABLE SITE DATA FLOW

PULSE RADAR

AN/FPQ-6 & AN/FPQ-18

DATA CHARACTERISTICS

Input: Synchro: Single speed 60 cycles for azimuth and elevation designate data

 Digital: Range designated by straight binary, 16 bits

Output:

Read out rate: 10/20 times/sec

Angle Encoders

Output word length: 20 bits

Azimuth and elevation word length: 19 bits

Resolution: 0.0122 mil/bit

Range:

Word length: 25 bits

Resolution: 1.953 yd/bit

CENTRAL DATA PROCESSOR (4101 COMPUTER)

Data: 30 bits, binary fractional, parallel transfer

Repertoire: Scientific, 40 basic instructions with 1675 variations

Memory: Random-access coincident-current magnetic core, 8192
30-bit words

Memory back-up: Magnetic tape storage

Error check: Overflow detection, parity check on memory transfer,
error check on input-output

Program priorities: 16

Logic type: NAND

Clock rate: 1 MHz

Performance: Memory cycle - 5.5 μ sec
Add time - 16.5 μ sec
Subtract time - 16.5 μ sec
Multiply - 75.5 μ sec
Divide - 73.5 μ sec

TARGET TRACKING RADAR (TTR)

The TTR is an on-axis, C-band, monopulse, computer-controlled, skin and beacon tracking radar. Originally installed and tested at Ascension Island as a prototype target tracking radar in the Nike-Zeus complex, the TTR was operationally accepted at AFETR on 15 March 65. A modification and testing program to provide on-axis capability for the TTR radar is in progress at the time of this submission for the AFETR Instrumentation Handbook.

LOCATION

<u>Station</u>	<u>Latitude</u>	<u>Longitude</u>	<u>Elevation</u>
Ascension Island	7°54'25.39"	345° 35' 49.28"	39.51 meters

PERFORMANCE CHARACTERISTICS

Transmitter

Frequency: 5250 to 5750 MHz
Pulse duration: 5 usec
Freq modulation: 10MHz linear chirp
PRF: 100 pps
Power Peak: 10 megawatts
Avg: 20 kw with 5us pulse

Receiver

Frequency: 5250 to 5750 MHz
Noise Temperature: 190 deg K
Collapsed pulse: 0.25 msec

Antenna

Mount: 3 axis (2 in use)
Dish shape: parabolic
Dish diameter: 28 ft
Feed: Cassegrainian
Gain: 53 db
Beamwidth: 0.6 deg
Polarization: vertical

PULSE RADAR

Coverage

Azimuth: 360 deg
Elevation: 0 to 90 deg
Range: 7623 NM on 100 M² target.

DATA HANDLING

The TTR on-axis configuration marries the Radar to a Sigma-5 computer. The Sigma-5 is replacing the NZAP computer, the Univac 1230, and SDS-92

Data: Raw range and angle data is read from the encoders and range buffer at 100 pps. The data is computer corrected and outputted on the console displays and data user. The console displays are updated at either 1 or 10 pps. The output data information rate is 10 pps formatted in eight 30-bit words. The data output is compatible with a standard transmission rate of 2400 bits per sec. The output data is synchronizaed to ETR timing. Data synchronization and internal rates are derived from an IRIG A timing signal.

DATA CHARACTERISTICS

Input Data: 1-speed synchro data for azimuth and elevation, IRV, NORAD Message, XYZ low density data, look angles

Output Data: 2-speed synchro data for azimuth and elevation
EFGT 10 pps data or AERT 10 pps data
XYZ low density data
TTY 100 wpm B3 format
38 character format
IRV (Inter-range Vector)

The systems also has a 2400 bps HDD transmitter and receiver system for radar designation.

LORAC

DESCRIPTION

Lorac (Long Range Accuracy) is a radio-positioning system operating in the medium frequency portion of the radio spectrum. Lorac provides position information for ships engaged in launch, tracking, and recovery operations. It also provides a standard of comparison for calibration of a ship's inertial navigation systems and associated equipment. The two networks installed at the ETR provide coverage from Cape Kennedy to Eleuthera.

A Lorac network consists of three base stations and one reference station. The three base stations are arranged in a triad (one center and two end stations) to provide coverage in the area of interest. The reference station is usually located in the vicinity of the center base station.

The three base stations operate in the continuous wave mode and generate a family of hyperbolas used to provide position information. The reference station operates in the amplitude modulated mode and provides the reference signal against which the phase measurements are made.

Each Lorac Network requires two carrier frequencies: one for the reference station and one for the base stations. While each base station operates on a different frequency from the other two, the difference is so slight the frequencies can be considered the same. The center base station operates at frequency f' while the end base stations operate at $f' + 135$ Hz and $f' - 315$ Hz respectively. The end base station, operating at $f' + 135$ Hz, is identified as the Green Station while the other is called the Red Station.

The reference station receiver receives the three base station signals and produces two heterodyne beat notes, 135 and 315 Hz, in its output. These signals are applied as modulation to the reference transmitter and transmitted at the frequency f'' .

The Lorac mobile receiver operating aboard ship contains two receivers which pick up the signals radiated from the base and reference stations. The outputs of these two receivers are filtered to provide four separate audio tones. Phase measurements are made on the 135 Hz pair and the 315 Hz pair continuously. The phase meters then display the position of the ship in hyperbolic coordinates. These readings are transferred to a navigation chart containing a hyperbolic overlay to determine the ship's position. Alternately, the position can be recorded for later reduction and conversion to any other desired coordinate system. Any number of mobile receivers can use the Lorac network simultaneously since the receivers operate in a completely passive mode.

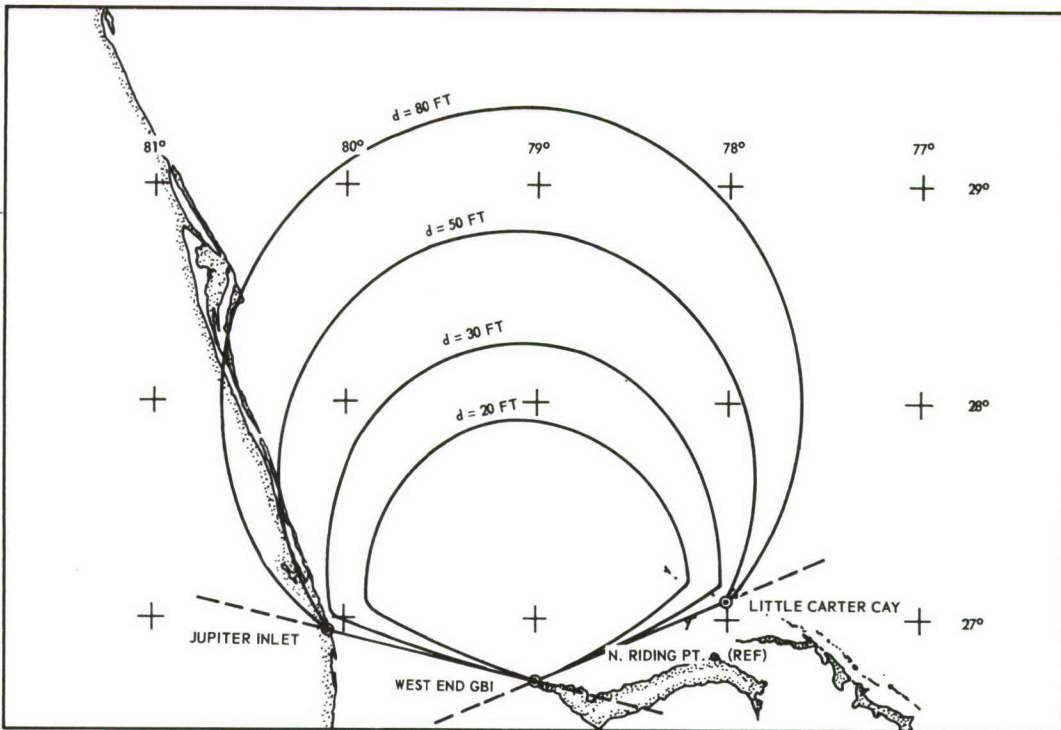

FIGURE 10 ERROR CONTOURS FOR ETR LORAC NETWORK A

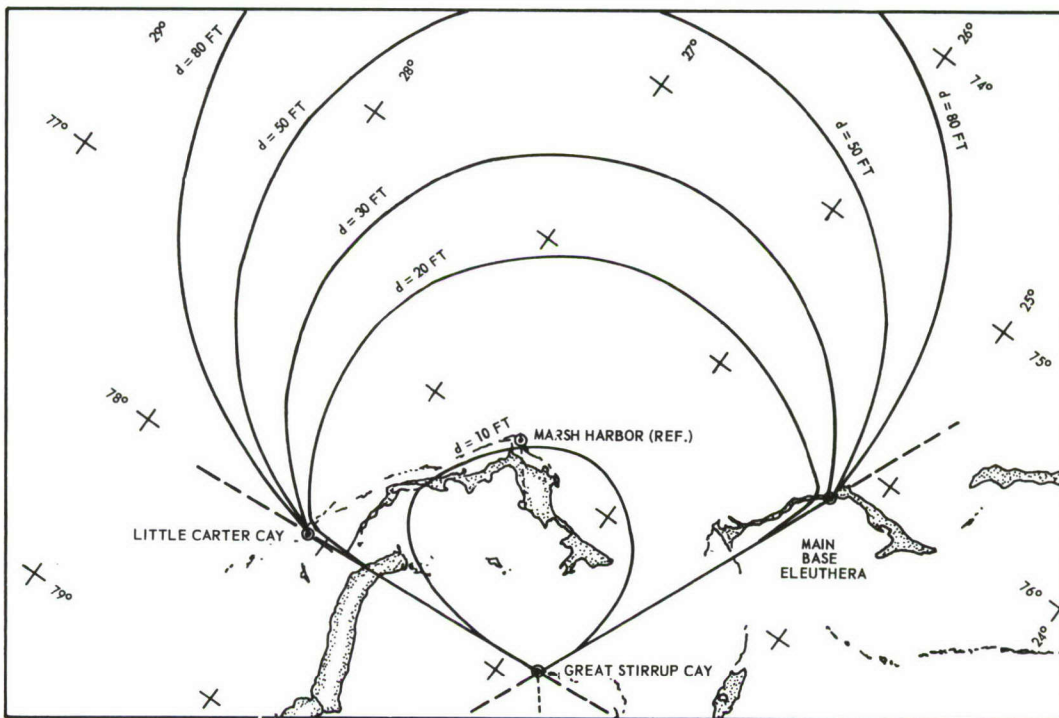

FIGURE 11 ERROR CONTOURS FOR ETR LORAC NETWORK B

LORAC

Each Lorac network has the following equipment:

<u>Quantity</u>	<u>Description</u>
3	Transmitters, 500 watts, CW
1	Transmitter, 500 watts, AM
4	Antennas, 260' - 280', insulated
1	Receiver, Pattern Monitor

LOCATION

Lorac A Network

<u>Location</u>	<u>Frequency</u>	<u>Type</u>
Jupiter, Fla.	1732.135 kHz	Green Base Station
West End, GBI	1732.000 kHz	Center Base Station
Big Carter Cay	1731.685 kHz	Red Base Station
North Riding Point	1773.000 kHz	Reference Station
Allans Cay		Pattern Monitor

Lorac B Network

Big Carter Cay	2099.685 kHz	Red Base Station
Great Stirrup Cay	2100.000 kHz	Center Base Station
Eleuthera	2100.135 kHz	Green Base Station
Marsh Harbor, Abaco Island	2415.842 kHz	Reference Station
Allans Cay		Pattern Monitor

ACCURACY

Error contours for the two ETR Lorac networks are shown in the following drawings. While the contours are based on the Geometric Dilution of Precision (GDOP), measurements taken against other systems, such as optics and radar, have shown that these errors are conservative.

BALLISTIC CAMERA

Ballistic cameras are used at AFETR to provide a time history and single station trajectory of missile reentry trajectories. The wild BC-4 camera with a 300MM lens is used. These cameras are operated on board a support ship located in the reentry impact area. A spectral grating is used on one camera operating with an open shutter while the other camera is used without a grating and with the shutter operating at a synchronous speed of 10 or 20 PPS. The shutter pulses are recorded on an oscillograph timing recorder.

TECHNICAL CHARACTERISTICS

Film Plates

Type	Eastman Kodak 103F
Thickness	6MM, flat to 6 wave lengths of sodium light
Size	190 x 210MM with 180x180MM usable image area
Speed	ASA 100
Resolution	60 to 70 lines per millimeter

Lens

Focal length	300MM
Angular	33 degrees square
Aperture	117MM
F-Stop	F/2.6

CINETHEODOLITES

The cinetheodolite system covers missile flights from approximately 500 to 100,000 ft altitude, and is a main source of trajectory measurement data from 1,000 to 50,000 ft altitude.

ASKANIA KTH-53 CINETHEODOLITES

DESCRIPTION

The Askania KTH-53 cinetheodolite is a metric tracking instrument with a 35-mm double frame camera movement for data recording. One operator manually tracks the target in azimuth and elevation with the aid of a 20-power sighting scope. The film records images of the target, azimuth and elevation dials, binary time code, and frame count.

Pulses from central timing operate all the cameras at the selected frame rate to ensure that all instruments record data at the same time. The electronic controls at each site also synchronize the strobe lamps which provide light for photographing the azimuth and elevation dials. Data recorded by two or more cinetheodolites are used to derive (by triangulation) vehicle position as a function of time. From this, vehicle velocity and acceleration can be computed.

LOCATION

Three Askanias are mobile and may be located at selected universal camera sites. A fourth unit can be mounted in an astrodome-tower configuration. Surveyed target poles and fixed illuminated orientation target arrays (out-of-focus targets and collimator lens) provide zero references for the cinetheodolites.

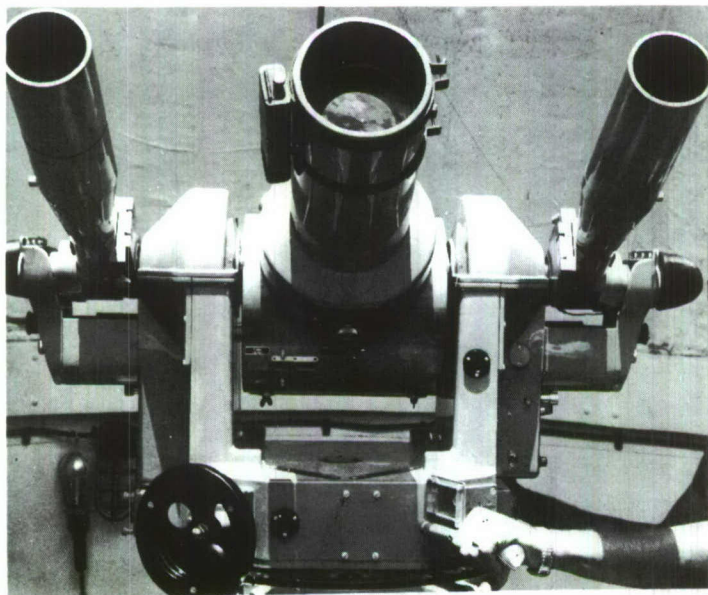

ASKANIA KTH-53
CINETHEODOLITE

METRIC OPTICS

CINETHEODOLITES

TECHNICAL CHARACTERISTICS

Exposure time: Fixed at 1/150 sec using a venetian-blind shutter

Camera drive: Pulse-operated mechanism

Frame rate: 1, 2, or 5 frames per sec (selected by a master station)

Film format: Double 35-mm format (1-1/2 x 1 in.)

Film load and running time: 125-ft magazine load with 140 sec running time at 5 fps

Lenses available: 12, 24, and 40-in. focal length

Timing: Binary code and frame count are recorded on the 35 mm film.

Maximum angular tracking rate: About 10 deg/sec

Sighting telescope: 20x elbow-sighting scope permits scope to rotate about eyepiece.

ACCURACY

Typical random errors in angles of a single cinetheodolite are 9 sec of arc. Systematic errors are about 21 sec of arc.

DATA HANDLING

Film is sent to Patrick AFB for processing and is read on a theodolite film reader. The reader produces digitized azimuth and elevation plotting angles of the cinetheodolite and tracking error XY coordinates of missile image position (with respect to the center of the film frame). Film reader output is recorded on paper tape and later converted to magnetic tape for postflight reduction of position, velocity, and acceleration data. The reading time for each frame with two film reader operators is approximately 20 seconds.

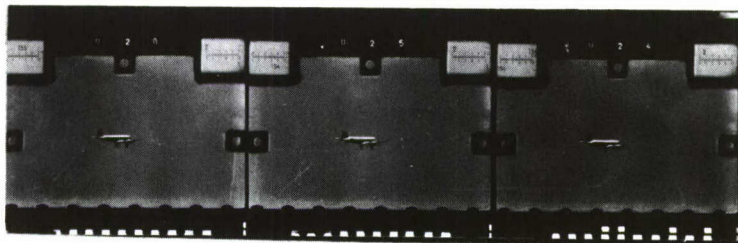
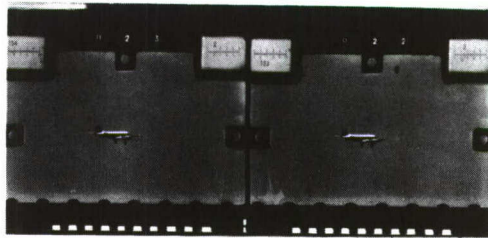

CINETHEODOLITE FILM

METRIC OPTICS
CINETHEODOLITES

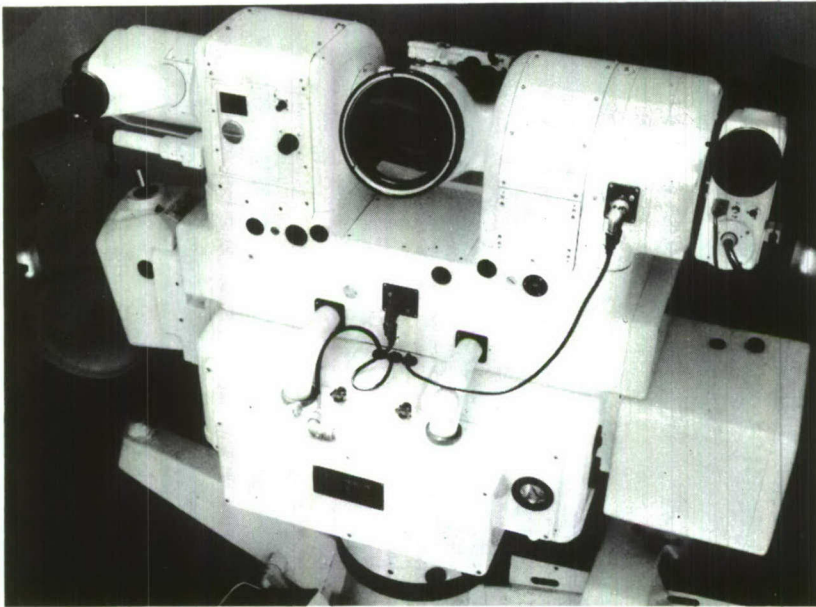

MOBILE
CONTRAVES
CINETHEODOLITE

MOBILE CONTRAVES CINETHEODOLITE SYSTEM

DESCRIPTION

The Mobile Contraves cinetheodolite is a metric tracking instrument with a 35-mm single frame camera movement for data recording.

One operator tracks the target in azimuth and elevation with a joystick controlling an angle-speed-acceleration type power driven tracking system. This system allows very smooth and precise tracking, free from the high momentary accelerations and corresponding flexure of the optical system and disturbance of the level of the instrument, characteristic of manual tracking.

A closed circuit television system, with the pickup camera mounted on the cinetheodolite and collimated with the objective, allows the Contraves cinetheodolite to be remotely controlled, permitting its operation in the danger area.

A trailer transports the cinetheodolite, the shelter, and all the necessary support and accessory equipment. Being mobile, these cinetheodolites may be placed for optimum launch coverage.

Preprogrammed focusing is provided for automatic focus from 2000 and 8000 ft to infinity for the 60 and 120 in. focal length target recording lenses, respectively.

If needed, accessory equipment can be procured in the future to provide a real-time output of the digital angles (excluding tracking errors). In this way angular values (of at least two cinetheodolites) can be processed in a central computer to give a real-time calculation of the trajectory (neglecting tracking errors).

METRIC OPTICS

CINETHEODOLITES

Seven mobile Contraves cinetheodolites are on hand.

LOCATION

Universal Camera Sites for cinetheodolites and other optical instrumentation are located at 23 sites throughout Merritt Island and Cape Kennedy. Fixed illuminated target arrays (out-of-focus and collimator lenses) provide zero references for the Contraves cinetheodolites.

TECHNICAL CHARACTERISTICS

Film: 35-mm single frame format (3/4 x 1 inch)

Magazine: 400-ft capacity

Frame rates: 5, 10, 20, and 30 frames per sec

Focal lengths: 60 in at f/8
120 in at f/16

Focusing: Infinity to 2000 ft for 60 in lens
Infinity to 8000 ft for 120 in lens

Sighting telescope: 12 power with 5.5° field of view and
20 power with 3.0° field of view

Leveling: To 2 sec of arc

Synchronization: All instruments to 100 usec

Velocity: Less than 0.015° per sec to 30° per sec

Acceleration: 0°/sec/sec to 45°/sec/sec

Digital encoding (Az/EI): Biquinary code recorded on the 35mm film

Static accuracy: 5 sec of arc, including compensation for systematic errors

Dynamic accuracy: 14 sec of arc

DATA HANDLING

The azimuth and elevation angle information are recorded directly on the Contraves cinetheodolite film in biquinary digital form, along with coded digital timing. The azimuth and elevation encoders use the "double circle projection" principle to record the angles with a least count of less than 8 seconds of arc. The azimuth, elevation, and timing digital information is read automatically by the film reader. In addition, the tracking error is read semiautomatically by an operator. The most accurate reading time is approximately 3 seconds per frame. Good quick-look data can be obtained with a reading time of 0.6 second for each frame. The data is punched out on IBM cards.

FIXED METRIC CAMERA SYSTEMS

DESCRIPTION

The standard fixed metric (ribbon frame) camera systems at the ETR are the CZR, RC-5, and RC-5A which are functionally identical, but have minor design differences. They record azimuth, elevation, and roll angles for the first several thousand feet of missile flight from which position, velocity, and acceleration data may be derived. Roll, pitch, and yaw data can also be obtained. The cameras are mounted on trailers. Domed shelters enclose the mounts and cameras.

A large, cylindrical, focal plane shutter drum encloses a continuous-motion film transport drum and a film magazine. The shutter and film move at a constant rate; therefore, the number of frames per second depends upon shutter drum openings. The shutter drum has six slots, spaced 60 deg apart, which may be closed off by shutter slides. One open slot will give 30 fps, two open slots opposite one another give 60 fps, three alternate open slots will give 90 fps, and all slots open will give 180 fps. Whenever the frame speed is changed, an aperture slide or framer must be inserted in the camera aperture to change the narrow dimension of the individual picture. The focal plane shutter drum is directly coupled to its synchronous motor which operates at 1800 rpm. Exposure time can be varied only by changing the size of the shutter slits that slide into the shutter drum slots. These slides have appropriate slits to give a 1/20,000 or a 1/40,000 second exposure.

A timing projector, in the stationary camera box, consists of a neon bulb and its wiring and is used to record a serial, elapsed-time code along the edge of the film. In this way, recorded data may be correlated to reference time.

The camera is mounted on a 3-axis precision gimbal mount. Azimuth, elevation and roll dials, leveling bubbles, and surveyed target poles are used for accurate prelaunch and postlaunch orientation. An electronic driver unit performs sequencing and start functions and supplies timing pulses in response to information from central timing.

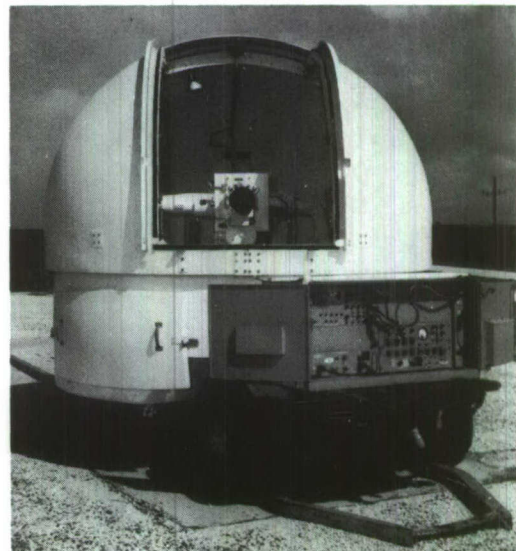

CZR-1 CAMERA

METRIC OPTICS

CZR-1

LOCATION

Precisely surveyed sites are located in the launch complex areas only. For each launch the CZR cameras are positioned at sites selected to give the required coverage and optimum geometric solution.

TECHNICAL CHARACTERISTICS

Exposure time: 1/20,000 second is standard

Frame rate: 30, 60, 90, or 180/sec

Frame format: 1.0 x 5-1/4 in. maximum

Narrow side varies with frame rate as follows:

30, 60, 90, and 180 fps; 1, 15/32, 5/16, and 5/32 in.

Film load and running time: 100-ft magazines allow 40 sec running time. Film width is 5.481 in.

Lenses available: 10-in. Elgeet is standard. Some cameras are also equipped to use 8-1/4 in. Schneider, or 6-in Metrogon.

Timing: Timing projectors with neon lamps imprint timing pips on edge of film. Correlation of timing to exposure is accurate to 1msec or better.

Mount dials: Reading capability to 0.005 deg (18 sec)

DATA HANDLING

Position can be found by triangulation using data from two cameras; however, more cameras are normally used to improve the accuracy. The processed film is previewed so that the best may be used (the computer routine for target position will accept up to 12 camera inputs). The initial orientation data is read on the more accurate Gaertner comparator and the remaining data on the faster Coleman reader (unless more accurate data is needed). Roll data can be obtained from the Gaertner comparator, and pitch and yaw data from the Aeronca improved attitude reader. Film reading data is recorded on paper tape and then converted to magnetic tape for computer processing.

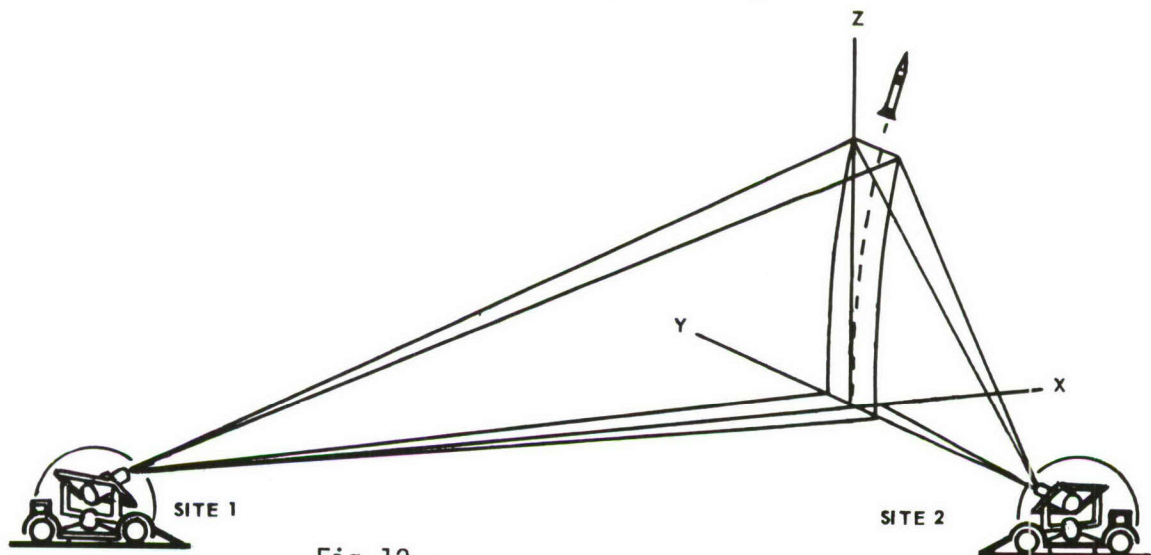

Fig 12 CZR CAMERA COVERAGE

ENGINEERING SEQUENTIAL AND DOCUMENTARY PHOTOGRAPHY HIGH-SPEED CAMERAS

MOTION PICTURE CAMERAS

There are over two hundred 16mm, 35mm, and 70mm motion picture cameras in the photo contractor's inventory. They are used to support DOD and NASA launch and non-launch engineering and documentary photo requirements. They are capable operation over a wide range of frame and shutter rates using internal and external magazine loads from 100 to 2000 feet and varied combinations of lenses and accessories to meet a broad range of requirements.

16mm Cameras

The 16mm inventory is composed of over 200 Mitchell, Milliken, Fastax, Arriflex, Auricon, Cine Special, Filmo and Hycam cameras capable of operation at frame rates from 12 FPS to approximately 4000 FPS using lenses of 5mm to 180 inches in support of launch and non-launch engineering and documentary photography.

35mm Cameras

There are over eighty Flight Research, PhotoSonics, Mitchell, Fastax, and Arriflex cameras in the 35mm inventory. These cameras are capable of operation at frame rates from below 10 FPS to over 1800 FPS using lenses of 50mm to 240 inches. They are used primarily in support of launch engineering and documentary photography.

70mm Cameras

The combined inventory consists of 44 Hulcher, Mitchell and Photo Sonics cameras operable at frame rates of 10 to 60 FPS with lenses of nominal length/aperture to the 500 inches of the ROTI and IGOR tracking telescopes. These cameras are used where a format larger than 35mm is required and most frequently are used on tracking mounts such as IFLOT, MOTS, ROTI, and IGOR to record missile flight performance and intermediate staging events.

Still Cameras

There are over 160 still cameras and ten aerial cameras in the photo contractor's inventory. These cameras range in format size from 35mm to 8x10 inches. With a wide range of lenses and accessories they are used in fixed positions or hand-held to support launch, non-launch, and aerial photo requirements.

INTERMEDIATE FOCAL LENGTH TRACKERS

IFLOT

DESCRIPTION

The intermediate focal length optical tracker (IFLOT) furnishes documentary, engineering, sequential, and attitude data at short and medium slant ranges. It was built at the ETR to provide better photographic coverage than previous trackers. Ten IFLOT Systems are available. These improved trackers operate in the KSC/ Cape Kennedy areas. The drive system has two enclosed oil-bath transmissions, preloaded tapered roller bearings, and is mounted on two-wheel trailers with precision jacks. The IFLOTs may be operated on support ships to cover sea launches. Each IFLOT accommodates up to four camera-lens combinations.

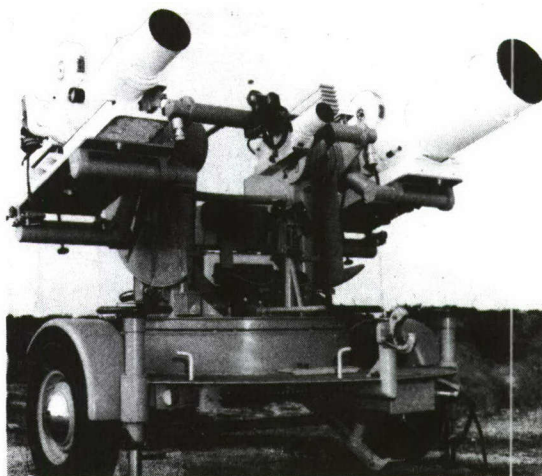

IFLOT

TECHNICAL CHARACTERISTICS

Camera: 16-, 35-mm Mitchell and 70-mm Photosonic or Hulcher
Focal length lenses accommodated: 20- to 240-in
Tracking rates: (elevation and azimuth): 22 deg/sec
Angular tracking limits: 350 deg azimuth and -10 to +90 deg elevation.

MOTS

DESCRIPTION

The mobile optical tracking system (MOTS) is a remote controlled system for use within the launch danger zones. The system has an infrared tracker for automatic track and a closed circuit television system for remote track. Each system consists of a pedestal trailer and a remote tracking console. Two camera-lens combinations may be used. The MOTS may be used outside of launch danger zones and can be operated at all KSC and most Cape Kennedy optical sites.

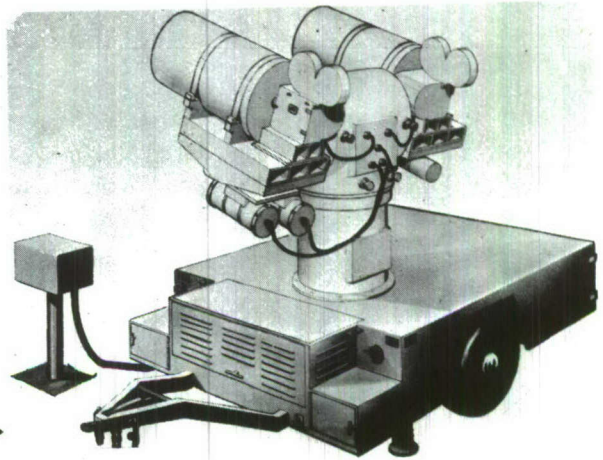

MOTS

Two systems are in operation.

TECHNICAL CHARACTERISTICS

Tracking rate - maximum: 30 deg/sec velocity; 60 deg/sec/sec acceleration

Focal length lenses accommodated: 20 to 180 in

Camera: 16-, 35-, and 70-mm

TV: Vidicon tube with television monitor and joystick control for remote track by operator in tracking console trailer. IR (lead sulfide sensor) Automatic Tracking System with 1 to 20 miles range.

Elevation range: -10 deg to +90 deg

Azimuth range: 350 deg

IGOR

The IGOR employs range DTS data to maintain correct focus at ranges of 3000 yards to infinity. The DTS angular data also serves as acquisition aid to operators in acquiring track and in maintaining track through weather obscurations. Automatic or manually selected exposure may be used. The IGOR requires two operators; one to track in azimuth and one in elevation with each using 20X or 35X sighting telescopes.

DESCRIPTION

The IGOR (intercept ground optical recorder) is a large tracking telescope system which takes time-correlated, high resolution, long range photographs of objects in space. It uses a modified Newtonian optical system, with an 18-in aperture and 90 in focal length. Amplifiers (Barlow type lenses) give added focal lengths of 180, 360, and 500 inches. The telescope is mounted on a modified Navy Mk27, 5-in gun mount. The 70-mm Photosonics or the 35-mm Mitchell camera may be used.

The 35-mm and 70-mm motion picture cameras are adjustable for frame rate, shutter opening, and "off-on" operation. They use either 400 or 1,000-ft capacity dark-room-loading, daylight-threading magazines. They are equipped with variable shutters, timing lights, fiducial markers, film footage counters, and film run-out switches.

An autofocus unit varies the focusing lens by a servo system. Servo input signals are derived from tracking radar information, corrected for parallax, and converted to slant range by coordinate converters. The coordinate converter takes X, Y, and Z data from a data receiver and converts it to azimuth and elevation voltages. Each azimuth and elevation tracking operator has a cathode ray tube display which shows the error between the telescope aiming and radar target position data. The Igor at Patrick AFB has an image orthicon TV system used for long range real time and photo/optical coverage.

LOCATION

A fixed Igor in an astrodome is located on a tower at Patrick AFB. Mobile units (so called Mobile Igor Tracking Telescope System, MITTS) may be towed to operating sites or transported by C-124 aircraft.

ENGINEERING SEQUENTIAL AND
DOCUMENTARY PHOTOGRAPHY
IGOR

TECHNICAL CHARACTERISTICS

Camera: BX-7 TU, 70-mm
Photosonics or
35-mm Mitchell

Frame rates: 10, 15, 30, 45 or 60
fps (70-mm); 8 to 96
fps (35-mm)

Aperture: 18 in.

Magazine capacity: 400 or 1,000 ft

Tracking rate: 10 deg/sec maximum

Angle limits: Continuous azimuth,
-3-1/2 to +92 deg
elevation (tower)
190° azimuth, -3-1/2
to +92° elevation
(mobile)

Sighting telescope magnification: 20 or
35

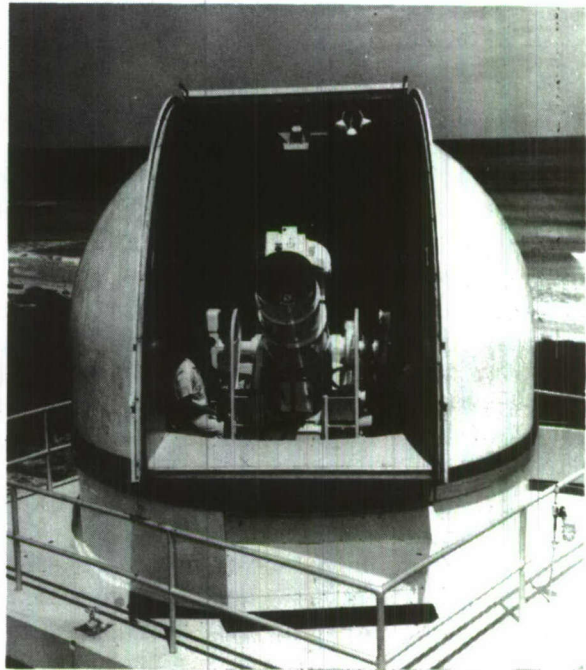

IGOR



MOBILE IGOR (MITTS)

ENGINEERING SEQUENTIAL AND
DOCUMENTARY PHOTOGRAPHY
ROTI

ROTI

The ROTI (recording optical tracking instrument) is a large tracking telescope system which takes time-correlated, high-resolution, long range photographs of objects in space. It uses a 24-in. aperture 100-in. focal length Newtonian optical system. Focal length increases are provided by Biotar relay lenses in increments of 100 in. to a maximum of 500 in. The ROTI has provided usable engineering photographs at distances exceeding 300 miles.

The telescope is supported by a modified Navy Mk 30, 5-in. gun mount driven by a hydraulic servo system for azimuth and elevation changes.

Controls are available for automatic focusing and exposure. The autofocus unit uses two glass wedges controlled by a range data from the target acquisition bus. The exposure device which automatically maintains constant illumination at the film plane uses counter-rotating variable density discs and a photomultiplier that compares the light entering the telescope with that from a standard light source.

The ROTI is protected by a 16-ft weather-proofed, dehumidified dome, automatically positioned in azimuth by a drive assembly synchronized to the telescope rotation. A curved door slides overhead to expose the telescope. Three tracking modes are possible:

- (1) Slaved to the target acquisition bus through data receiver and coordinate converter.
- (2) Slaved operation with operator override (servo error voltages are presented to the operator for correction)
- (3) Operator tracking by stiff stick which permits control of position, velocity, and acceleration motions of the instrument in both axes. The instrument can also be oriented by cranking the handwheels (but not for missile tracking).

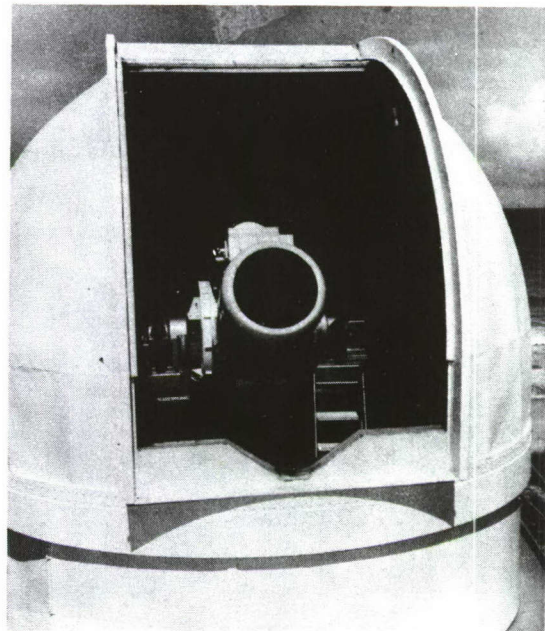

ENGINEERING SEQUENTIAL AND
DOCUMENTARY PHOTOGRAPHY
ROTI

LOCATIONS

Melbourne Beach

Cocoa Beach (Deactivated Status)

TECHNICAL CHARACTERISTICS

Film size: 35- and 70-mm

Focal length: 100, 200, 300, 400, and 500 in.

Aperture: 24 in.

Magazine capacity: 400 or 1,000 ft

Frame rates: 10, 20, 30, 40, or 60 fps (70-mm); 8 to 96 fps (35-mm)

Tracking rate: 10 deg/sec maximum (increased by override function)

Angle limits: 720-deg rotation in azimuth

-10 to 190 deg elevation

Sighting telescope magnification: 10, 20, and 40

Visual null unit: CRT display with crosshairs and a dot which moves according to the radar angular position data. This maintains track even though the target may not be visible.

MISSILE IMPACT LOCATION SYSTEM MILS

DESCRIPTION

Mils is an underwater sound detection and location system used to obtain the geographic position of a nosecone or a data capsule dropped anywhere along a flight azimuth on the ETR. The system is based on (1) the production of sound generated by impact of a nosecone or other missileborne objects on the surface of the water, or by the underwater explosion of a bomb carried by a missile component and on (2) the detection of the sound and recording of its arrival time at a number of known hydrophone locations in the ocean. The location of the impact or drop point can be computed from a knowledge of the hydrophone positions, the velocity of propagation of sound in the ocean, and the arrival times of the sound at the hydrophones.

The Mils used on the ETR consist of two types: the target array (also called pentagon or splash array) and the sofar system (also called the broad ocean area, or BOA). The target array provides high accuracy information in a limited target area, usually within a 10-nm radius. The hydrophones are placed on the bottom in essentially a regular pentagon formation with a sixth hydrophone at the center, the target area being the water surface above the pentagon. The sound transient produced at the surface by an impacting nosecone travels through the water to the hydrophones. The computation for impact location is the conventional space hyperbolic solution in which the z term (altitude) is a constant equivalent to the depth of the water. The pentagon configuration ensures that for any point of impact within the target area there will be at least four hydrophones

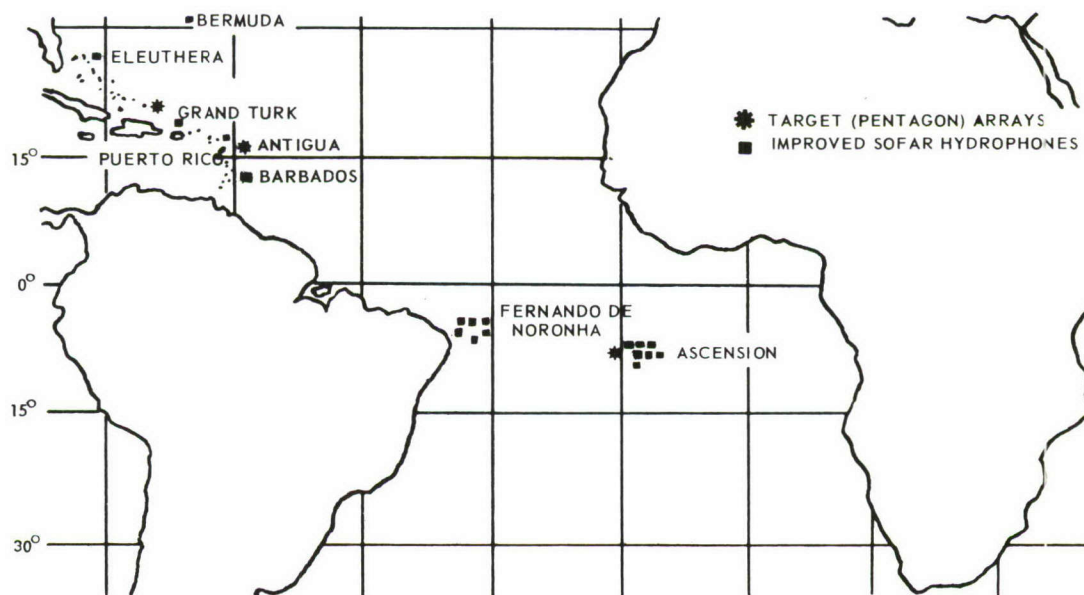

FIGURE 13 ETR MILS LOCATIONS

IMPACT LOCATION SYSTEMS MILS

with ranges less than the refraction limit so they will receive signals by a direct transmission path.

The BOA configuration is essentially a plane hyperbolic system taking advantage of the long range sound transmission (about 2,000 nm) and the superior identification characteristics of the sofar channel. An inversion point, or minimum velocity of sound, is formed at a depth of 3,000 to 4,000 ft by decreasing temperature and increasing pressure. At the depth of minimum velocity, attenuation of sound energy with distance is nearly linear rather than proportional to the square of the distance, and even comparatively low level sounds can be detected at great distances. The BOA hydrophones are placed as close as possible to the sofar axis. A sofar bomb with pressure-activated control is mounted in the reentry body and allowed to sink with it until the bomb detonates near the sofar channel. The accuracy of the system depends on the geometrical relationship of the impact position to the hydrophone positions, signal timing and on the velocity of sound propagation. There are many sound paths between the explosion point and the hydrophone positions, resulting in many sound arrivals at any one hydrophone from a single explosion. However, the sound path along the sofar axis, traveling in the plane of the system and at the lowest velocity, is the last arrival to a hydrophone and can be identified. Its time of arrival together with hydrophone position and values of "horizontal velocity" (measured by calibration) are the inputs for computing the impact location. Data from at least three hydrophones is needed for a solution.

The geodetic accuracy of the BOA has been improved at specific midrange impact areas by calibration (measurement of acoustic propagation velocity) near the time of the missile test. The calibration consists of a ship releasing a few sofar bombs while the ship's location is being determined by Acoustic Ship Positioning System (ASPS) bottom transponders. Three transponders, placed in each impact area, are interrogated by a pulse from the ship, and reply at individual frequencies. The geodetic position of the transponders is surveyed by the most accurate method available, i. e., BRN-3 or star tracker.

Impact location (geodetic and relative) of multiple reentry vehicles is provided in the BOA by varying the amount of explosive carried in the sofar bomb. An approximate 5 db difference in the peak signal level is observed when the charge weight is doubled. The charge weights recommended for midrange areas are 1, 2, and 4 pounds for three reentry vehicles.

LOCATION

Target Array (hydrophones positioned on bottom)

- Grand Turk (75 miles north of, at a depth of 3 miles)
- Antigua (150 miles northeast of, at a depth of 3 miles)
- Ascension (35 miles west-south-west of, at a depth of 2 miles)

IMPACT LOCATION SYSTEMS
MILS

BOA Array (BOA hydrophones positioned at or near the sofar axis)

- Barbados
- Bermuda
- Eleuthera
- Antigua
- Grand Turk
- Puerto Rico
- Ascension
- Cape Hatteras
- Eastern Atlantic

ACCURACY

Accuracies of the Mils systems are classified Confidential. They may be obtained from Missile Impact Locating Systems Supplement to RCA Systems Analysis Quarterly Accuracy Bulletin No. 25 (U), 30 Mar. 68, Secret.

DATA HANDLING

The hydrophone outputs of the arrays are recorded simultaneously on strip-charts with timing annotation and on magnetic tape with timing and operator voice annotation. Arrival times are obtained manually at each site from the strip-chart recordings and transmitted by teletype to the computer center at Patrick AFB, where a quick-look impact point is calculated. The strip-chart and magnetic tape recordings are then forwarded to Patrick AFB for postlaunch data processing and correlation with other tracking sources. Data is also transmitted in real time from Antigua and Ascension to PAFB for quick-look analysis.

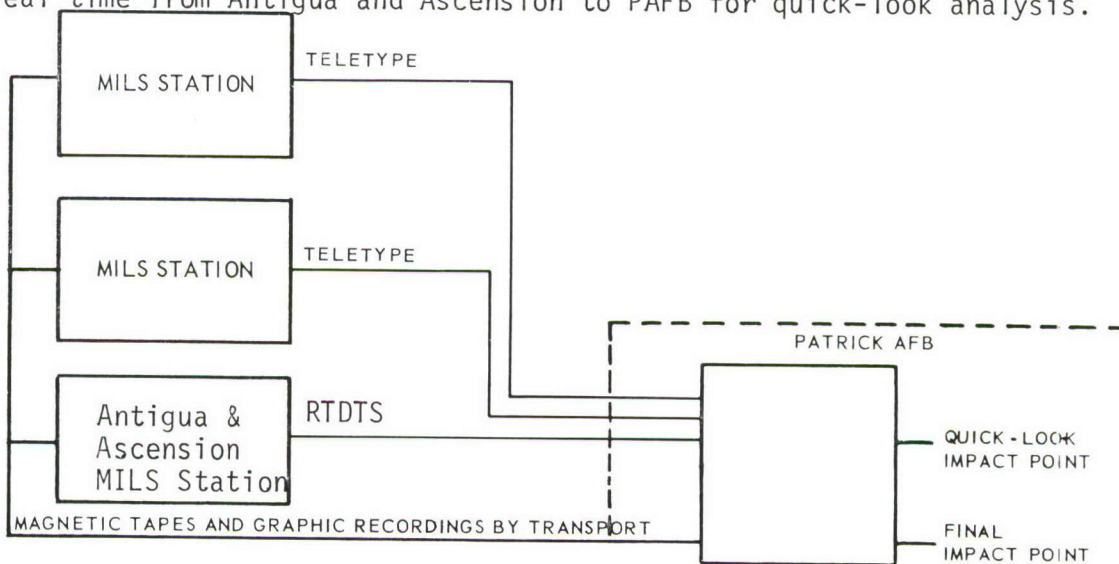

FIGURE 14 MILS DATA HANDLING

IMPACT LOCATION SYSTEMS

SMILS

SONOBUOY MISSILE IMPACT LOCATION SYSTEM

DESCRIPTION

The SMILS (Sonobuoy Missile Impact Location System), used to determine the impact location of missile re-entry bodies, consists of four basic elements; (1) an ocean bottom acoustic transponder array; (2) specially equipped P-3 ORION aircraft; (3) modified Navy ASW sonobuoys; and, (4) ocean surface duct.

The transponder arrays in the impact area consist of three to nine ASPS (Acoustic Ship Positioning System) transponders which serve as a geodetic reference point for the sonobuoys. These transponders are energized by a 16KHz interrogator signal and respond each on a different frequency at 1/2 KHz intervals from 9.5 to 12 KHz. Each transponder array is located geodetically by the Navy Satellite System.

Two Navy P-3 ORION Lockheed Electra ASW aircraft assigned to the Air Test and Evaluation Squadron One (VX-1), Key West, Florida, have been modified to accommodate the SMILS. These modifications provide: (1) the capability to receive and record additional sonobuoys (24 and 32 respectively); (2) a timing system; and (3) a monitoring and quick look recording capability.

The standard ASW sonobuoy AN/SSQ-41 is an expendable item designed to be dropped into the sea from an aircraft. When so placed in the sea it detects underwater sounds, and by means of a self-contained transmitter relays this information to the aircraft. There are 31 transmitter frequency channels between 162.25 KHz to 173.50 KHz. The sonobuoys are modified to increase the active life by installing additional batteries, and the circuitry is changed to increase the frequency response in order to receive the ASPS transponder interrogator and reply signals. In addition, some of the sonobuoys are modified to incorporate a low frequency (2.5 KHz) pinger. An interrogator sonobuoy is deployed by a ship in the center of the ASPS transponder array. This device is essentially an AN/SSQ-41 sonobuoy modified to transmit a 16 KHz signal, and to receive the 9.5-12 KHz transponder response signals. An air droppable interrogator sonobuoy is under development.

The wind mixed surface layer of the ocean creates an isothermal duct or wave guide through which sound reliably propagates for many miles. Splash signals have been received through this surface duct at ranges up to 20 miles. The depth of the ocean duct is determined by means of a bathythermograph sonobuoy dropped from the SMILS aircraft. The depth

together with the planned re-entry body impact footprint are used to determine the sonobuoy pattern to be employed.

A typical sonobuoy pattern for a single aim point footprint consists of four rings about three nautical miles apart with a total outside diameter of about twenty nautical miles. Some thirty modified AN/SSQ-41 sonobuoys and an interrogator sonobuoy are deployed during each mission.

The ASPS transponders which are energized by the 16KHz interrogator signals serve to locate the 2.5 KHz pinger sonobuoys relative to the transponders. The signals from these pinger sonobuoys which propagate through the surface duct are then used to locate the other sonobuoys. When an re-entry body impact occurs the splash signal propagates through the surface duct and is received by the sonobuoys. The splash position relative to the sonobuoys as well as the time at which splash occurred can then be determined.

LOCATION

The POSEIDON impact areas to be supported by SMILS are C11A, C9C, C15A, and C15N. PRD-700 contains descriptions and the locations of these impact areas.

ACCURACY

Accuracies of the SMILS system are classified SECRET. They may be obtained from the Navy Strategic Systems Project Office (SSPO), Washington, D.C.

OPERATIONS

The AFETR is responsible for the overall operation and funding of SMILS. A Joint Memorandum of Agreement has been effected between the Strategic Systems Project Office (SSPO) and the Air Force Eastern Test Range for Navy support and services associated with SMILS.

Briefly, the Navy will provide the P-3 aircraft support and various other services on a reimbursable basis (through the Palisades Geophysical Institute, Bermuda) such as sonobuoy acquisition/modification, mission planning/support, and data analysis/reduction.

The AFETR will provide the transponder arrays (by acquisition, installation and survey of transponders) as well as maintain an aircraft navigational aid in the impact areas.

The P-3 aircraft navigational aid (NAVAID) requirement in the impact area for Poseidon demonstration and shakedown operations (DASO) will be met by the use of an instrumented ship (RIS or AIS) which is already required in the area for metric and other support. The NAVAID requirement in the C15A and C15B impact areas for Poseidon operational tests/follow on tests (OT/FOT) will be met by the use of the oceanographic vessel (Sir Horace Lamb), leased from the Palisades Geophysical Institute on a per mission basis, since the Range Instrumented Ship will be used as a Down Range Support Ship (DRSS) in the uprange area nearer to launch point. This method of SMILS support will continue indefinitely as long as the Range Instrumented Ship and Sir Horace Lamb are available. If, in the future, a vessel is no longer available in the impact area, then an anchored marker buoy must be acquired as a NAVAID.

TELEMETRY

DESCRIPTION

In the test and development phases of missile and spacecraft programs, the performance of the structures, propulsion systems, and electronics components must be checked in flight. Performance data is obtained by monitoring measurement instruments (transducers) on board the vehicle. The outputs of the transducers modulate (amplitude, frequency, or phase) an RF carrier which is transmitted to a ground station. Frequency or time multiplexing permits several channels of information to be transmitted over a single RF link. The following common modulation schemes are transmitted by vehicle telemetry systems (telemetry standards are given in IRIG Document 106-66).

FM/FM In this scheme transducer outputs are frequency division multiplexed by connecting each transducer to a different subcarrier oscillator which produces frequency modulated signals with different center frequencies. These channels are summed and used to frequency modulate the RF carrier.

SS/FM This type of modulation is an efficient data bandwidth system using single sideband modulation. The separate wideband channels (3 kHz) are transposed in frequency to their baseband positions. These single sideband signals are then summed and the composite signal is used to frequency modulate the transmitter. SS/FM is currently being used to telemeter vibration data from large rocket boosters.

PAM Pulse amplitude modulation (PAM) is a method of time division multiplexing data from many analog transducer sources. A commutator is used to sample these data sources sequentially and this output pulse train is used to modulate the telemetry transmitter (PAM/AM, PAM/FM, PAM/PM). However, PAM may modulate baseband subcarriers or sidebands which, when summed, modulate the telemetry transmitter yielding PAM/FM/FM, PAM/AM/FM, PAM/FM/PM, etc.

PDM In pulse duration modulation (PDM, sometimes called PWM - pulse width modulation) the time duration of the pulse is proportional to the amplitude of the information to be transmitted. As in PAM, the outputs of the transducers are connected to commutators to produce a PAM pulse train. This train is then converted to a PDM pulse train with pulses of constant amplitude but varying time duration. The PDM waveform may then modulate the transmitter as in the PAM system above (PDM/FM, PDM/FM/FM, etc).

PCM Pulse code modulation (PCM) makes use of binary techniques which allow superior noise immunity as compared to the previously mentioned systems. The transducer outputs are connected to the commutator as in PAM; however, this PAM train is fed into an encoder which quantizes the PAM pulse into

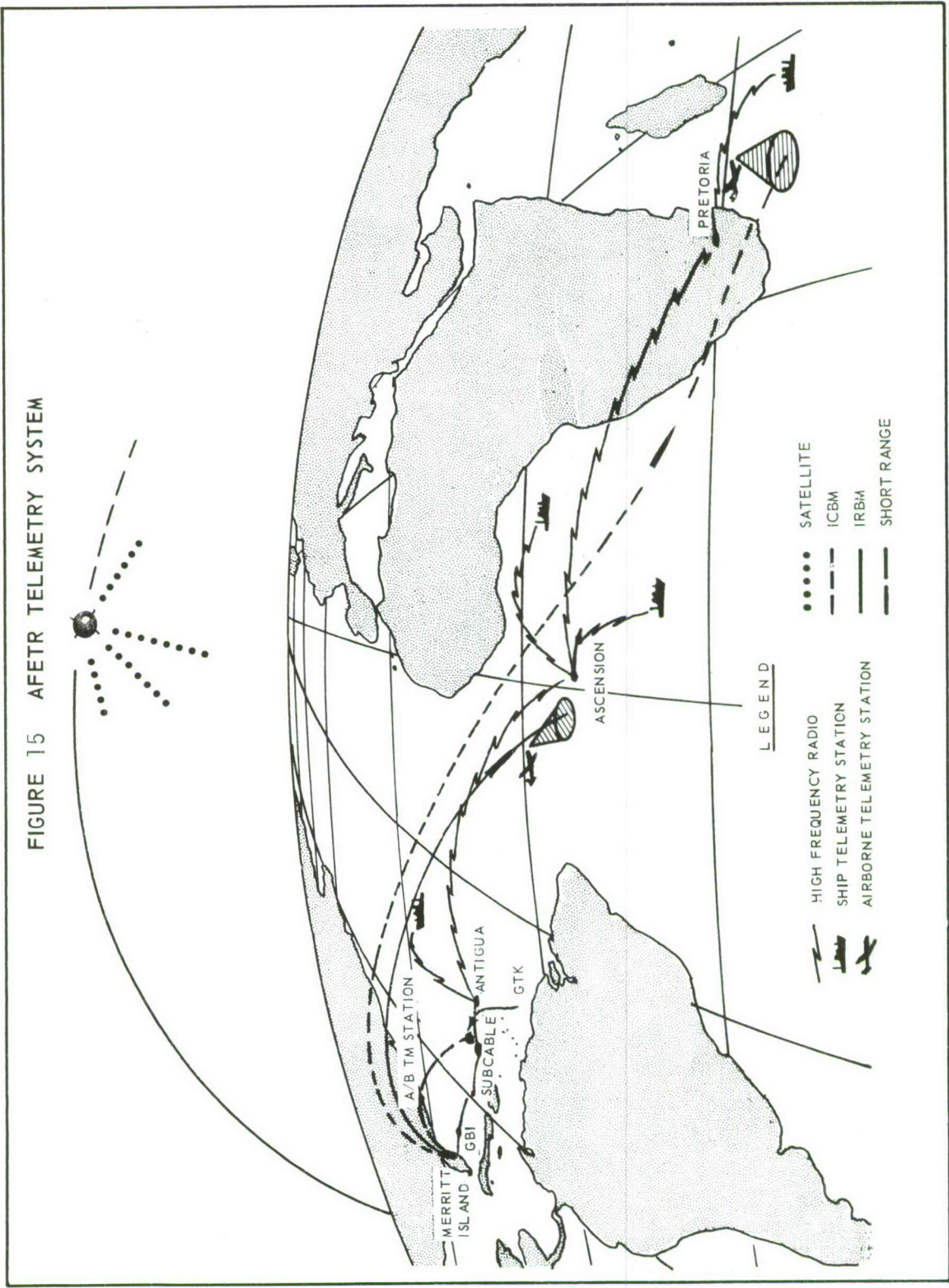

FIGURE 15 AFETR TELEMETRY SYSTEM

discrete levels. A series of N successive weighted bits, directly related to the quantizing level, is then formed. The greater the number of bits or discrete quantizations, the greater the accuracy of the sampled data. Since the existence or absence of the pulses is required, only two signal levels need be transmitted; one representing a 1, and the other a 0.

A number of different waveforms can be used to represent the 1 and 0 bits. Among them is the non-return-to-zero level (NRZL) in which a 1 bit is one signal level and a 0 bit is a different level. Nonreturn-to-zero mark (NRZM) is a waveform in which a bit is shown by a change in level to either direction and a 0 bit by the absence of a change in level. In the return-to-zero wave form (RZ) a finite width pulse, usually half-bit width, is generated to mark a 1 bit.

PCM can be modulated on the telemetry RF link as in the previously mentioned schemes (PCM/AM, PCM/FM, PCM/PM, PCM/FM/FM, etc). In addition, PSK (phase shift keying) and FSK (frequency shift keying) can be used with PCM (PCM/PSK, PCM/FSK). However, special equipment in addition to the basic phase-lock loop must be used at the ground station to detect PCM/PSK; hence PCM is usually transmitted on a sine wave or square wave subcarrier as PCM/PSK/PM.

The ETR telemetry system includes ship, airborne, and ground stations (both mobile and permanent). These are classified as launch area, downrange, or transportable stations, depending on their location or area of operation. Ships

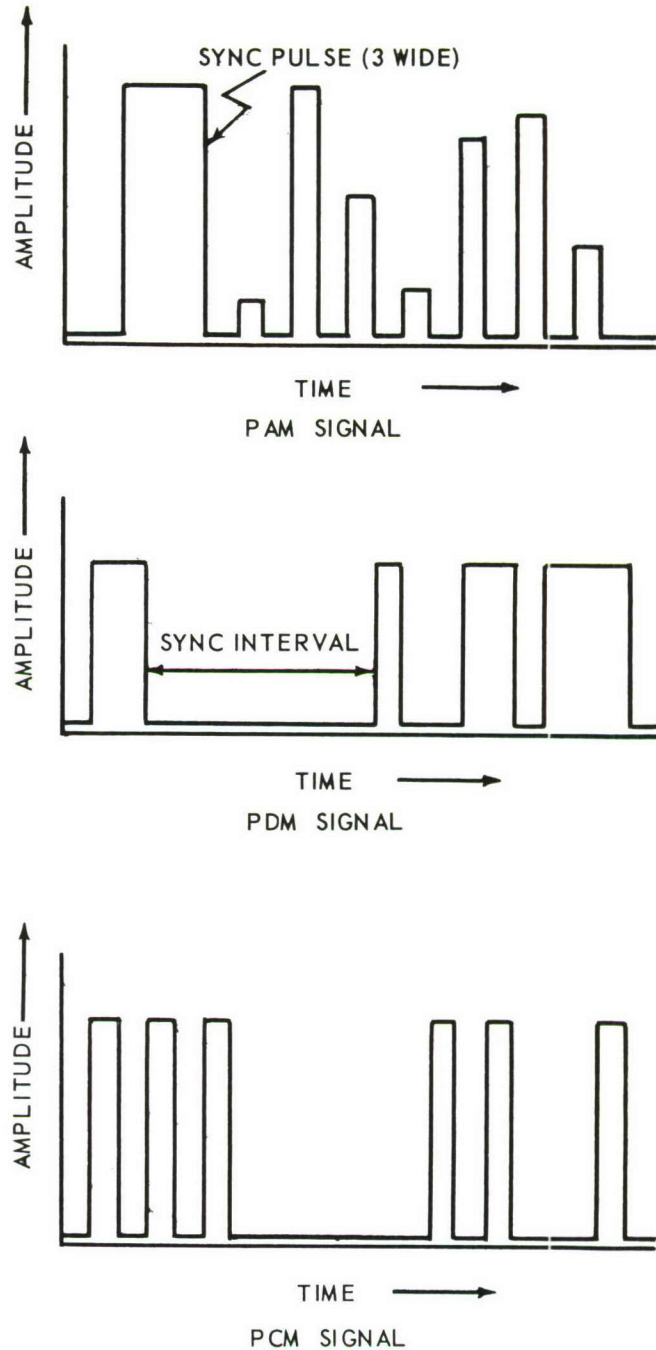

FIGURE 16 TYPICAL TDM WAVEFORMS

TELEMETRY

are usually used in downrange locations to obtain midcourse, reentry, and impact data; mobile ground stations are used downrange and in the launch area. The overall ETR telemetry system with a typical deployment of ship and air-borne telemetry stations is shown on page 100.

Telemetry data is primarily recorded on magnetic tapes, strip charts, or oscillographic paper for later distribution to range users. Selected data from the downrange stations can be retransmitted via the RTTDS from downrange land and ship stations and displayed in real time or near real time at the Central Telemetry Station (Tel 4) or forwarded to the Real Time Computer System (RTCS) and range user locations at CKAFS. The quantity of this data is limited by the communications bandwidth of the subcable or the HF link where applicable. The AFETR Telemetry System Communications setup is shown on page 103. Magnetic data tapes from downrange stations are returned to Tel 4 for processing. Analog records (strip chart or oscillographic), magnetic tape copies, and computer formatted tapes can be prepared at the request of the range user.

The AFETR's Central Telemetry Station is located on Merritt Island. Here data is received, recorded, separated, displayed, and formatted for pre-launch, launch, orbital and pad support operations.

FIGURE 17. AFETR TELEMETRY SYSTEM COMMUNICATIONS

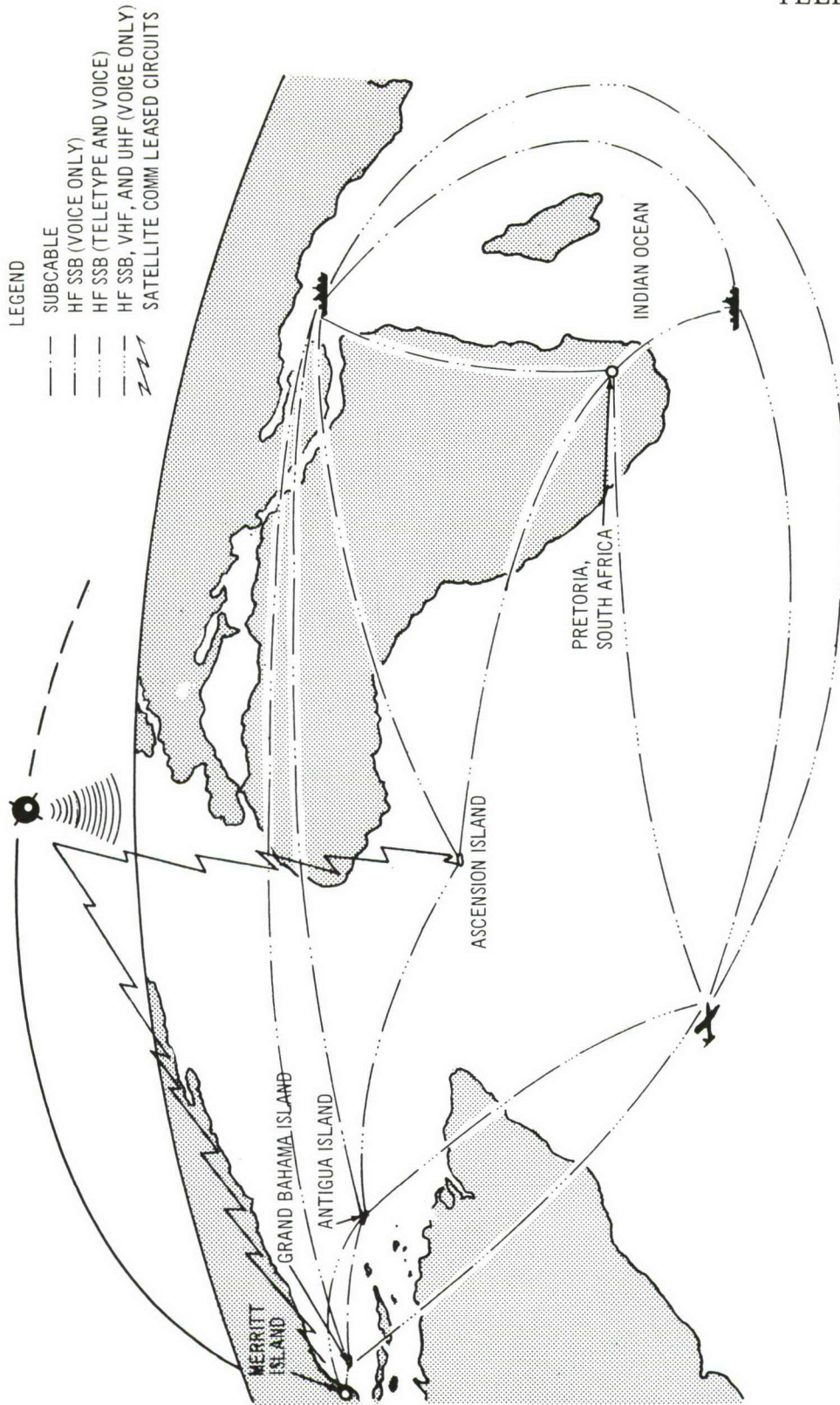

TELEMETRY

The Central Telemetry Station is an integrated telemetry data processing facility. Each of the many and different types of data processing subsystems has been made compatible with other related subsystems. This versatility is augmented by a remote-patching/status-display/remote-control system which provides the facility for rapid setup and operational control over the many simultaneously-functioning units. From a centrally-located control room, controllers program and execute computer commands which arrange and rearrange the many subsystems into the required mission configurations. Up to seven separate missions may be configured and coordinated simultaneously with the identification and equipment status of each clearly indicated to the launch coordinator console operators.

The subsystems comprising the Tel 4 Station are functionally divided into six major systems: Data Acquisition and Storage; Data Separation; Data Processing; Data Recording and Display; Control, Status Display and Patching; and Central Communications Interface.

The telemetry data handling and processing capabilities provided by these systems include acquisition, storage, frequency division multiplex separation, time division multiplex separation, processing, strip-chart recordings, visual displays, preparation of computer-formatted magnetic tapes, tape copying, tape playback, and interface for video retransmission. The antenna and receiving systems cover 130 MHz to 2,300 MHz in discrete bands. Radio frequency carriers may be frequency-modulated, amplitude-modulated, or phase-modulated with FM, AM, PAM, PDM, PCM, or PACM intelligence. Either predetection or video magnetic tape recordings may be produced.

Both time division multiplex and frequency division multiplex signals may be separated and presented for recording and display. Digital-to-analog and analog-to-digital conversion equipment make it possible to present either form of data to both digital and analog recording/display devices. Four separate display areas are equipped with direct-write pen recorders, oscillographic recorders, analog bar-graphs and digital displays for the convenience of range users. Computer-ready magnetic tapes may be formatted in real time or from stored data tapes. Facilities are provided to produce duplicate predetection or video magnetic tapes.

The data flow philosophy of the Tel 4 Station is conventional. Acquired data is recorded on magnetic tape, and/or after separation and conditioning, recorded on strip charts and visually displayed. Interconnection of the data handling system is, however, largely accomplished by remotely-controlled switches rather than through the use of manual patch panels. In addition to switch closures, the Control, Status Display and Patching System provides for equipment status signals and remote operation of the station data recorders.

Each major functional unit in the station can be manually patched or remotely switched to operate with any other major unit or units. Intra-system patches are accomplished manually, while inter-system patches are accomplished by remotely-controlled cross-bar type switches. These switches allow any input line to be connected with any combination of output lines. Switch (patch) control is exercised from a console through a computer which selects the patch to be followed through each switch matrix.

The Central Communications Interface (CCI) patch permits switchable patching of other range land lines with voice communications lines, analog and video remote patches within Tel 4, and video data manual patching to the video manual patch (VMP) and the Tel 4 Centralized Data Switching and Monitoring Console.

External data communications with Tel 4 through the CCI includes narrow and wideband serial digital PCM and real-time analog data. Video signals are routed via multiplexing equipments and wideband A2A lines. Serial data is handled and conditioned for transmission by wire line modems.

The following paragraphs describe the ETR ground station equipment. Telemetry instrumentation for ships and aircraft is discussed in the SHIPS AND AIRCRAFT section.

TELEMETRY

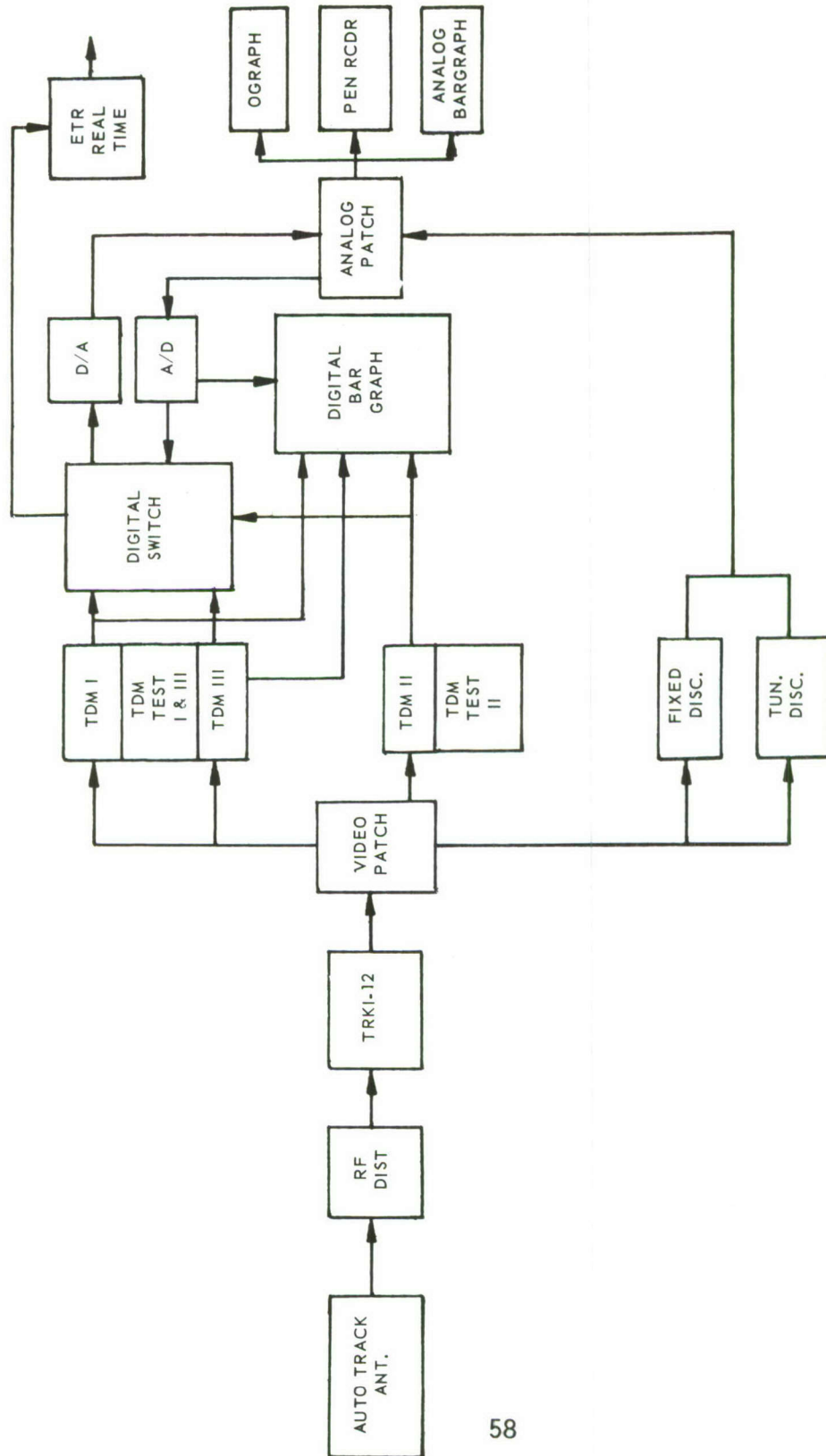
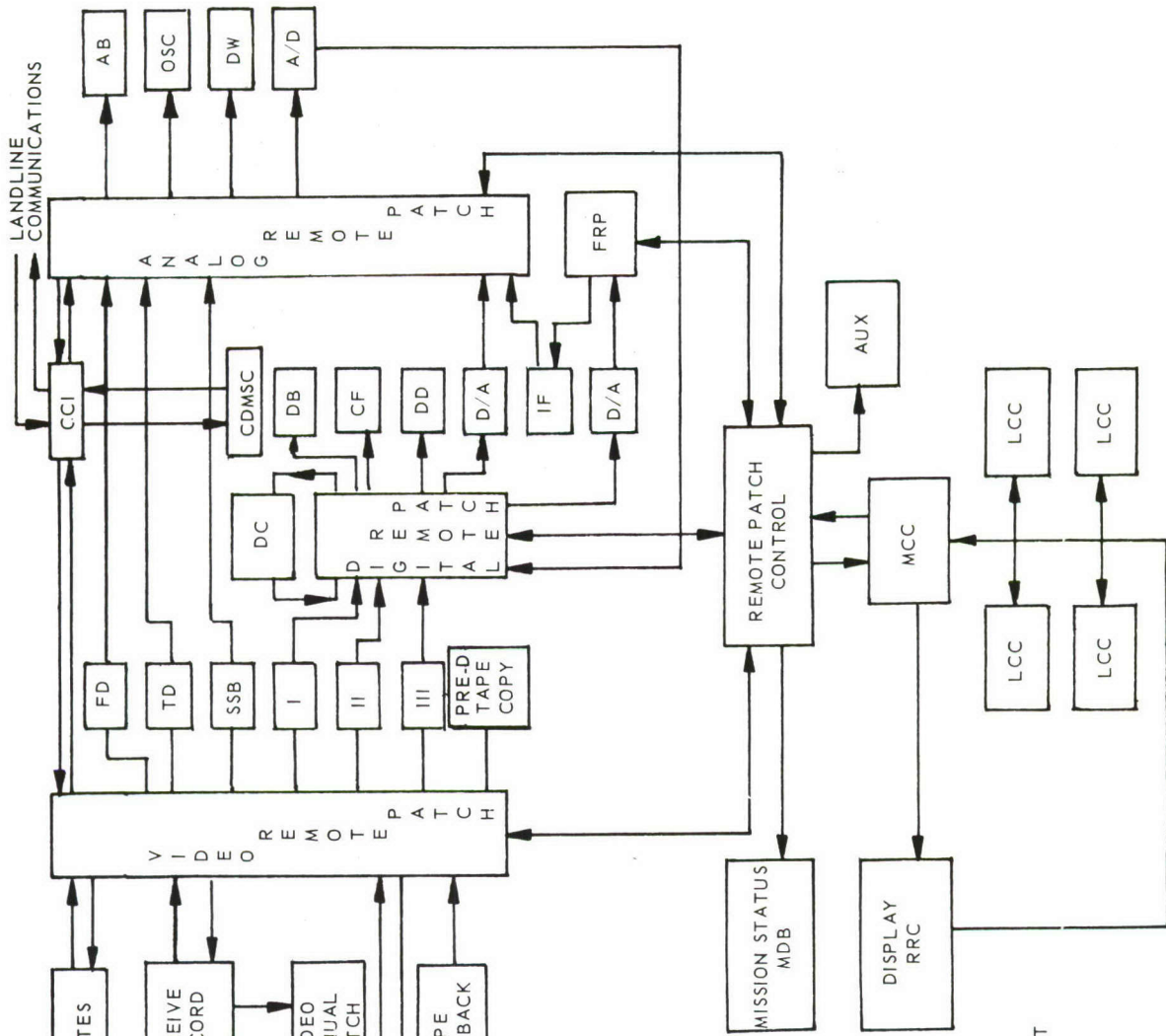

FIGURE 18. TYPICAL DOWNRANGE STATION SYSTEM BLOCK DIAGRAM



- FD FIXED DISCRIMINATORS
 - TD TUNABLE DISCRIMINATORS
 - SSB SINGLE SIDEBAND
 - I TIME DIVISION MULTIPLEX TYPE I
 - II TIME DIVISION MULTIPLEX TYPE II
 - III TIME DIVISION MULTIPLEX TYPE III
 - DC DATA CORRECTOR
 - DB DIGITAL BARGRAPH
 - CF COMPUTER FORMATTER
 - DD DIGITAL DISPLAY
 - IF INTERPOLATION FILTER
 - D/A DIGITAL TO ANALOG CONVERTER
 - FRP FILTER REMOTE PATCH
 - AB ANALOG BARGRAPH
 - OSC OSCILLOGRAPH
 - DW DIRECT WRITE PEN RECORDER
 - A/D ANALOG TO DIGITAL CONVERTER
 - MCC MASTER CONTROLLER CONSOLE
 - LCC LAUNCH COORDINATOR CONSOLE
 - MDB MASTER DISPLAY BOARD
 - RRC REMOTE RECORDER CONTROL
 - AUX CONTROL TAPE PREPARATION EQUIPMENT
- MATES MAGNETIC TAPE EVALUATION SYSTEM
 CCI CENTRAL COMMUNICATIONS INTERFACE
 CDMSC CENTRALIZED DATA MONITORING AND SWITCHING CONSOLE

FIGURE 19, TEL 4 SYSTEMS BLOCK DIAGRAM

TELEMETRY

TABLE I
TELEMETRY EQUIPMENT DISTRIBUTION

	<u>TEL 4</u>	<u>GBI</u>	<u>GTK</u>	<u>ANT</u>	<u>ASC</u>	<u>PRE</u>
Antennas						
TAA-2	-	1	-	-	-	-
TAA-3	-	-	1	-	-	-
TAA-3A	1	1	-	1	1	-
TAA-8	-	-	1	-	-	-
TAA-8A	-	-	-	1	-	-
AT-36	-	-	-	-	-	1
TAM-1	2	-	-	-	-	-
Log Periodic	-	-	-	-	-	1
Trihelix	1	-	-	-	1	-
Receiver/Recorder System						
TRKI-12	5	2	2	3	2	1
RF Distribution	5	3	1	2	1	1
RF Calibration	1	1	-	-	-	-
Tape Copy System Post-D	1	-	-	-	-	-
Tape Copy System Pre-D	1	-	-	-	-	-
Remote Recorder System, TKM-1	1	-	-	-	-	-
TLM Tape Playback Subsystem TDM-1	1	-	-	-	-	-
SS/FM Demultiplexer	1	-	-	-	-	-
M-29 DITAR	1	1	-	-	-	-
TDM Type I Decommulator	4	2	1	3	2	2
TDM Type II Decommulator	3	1	-	-	-	-
TDM Type III Decommulator	5	-	-	1	1	1

TELEMETRY

TELEMETRY EQUIPMENT DISTRIBUTION (CONT'D)

	<u>TEL 4</u>	<u>GBI</u>	<u>GTK</u>	<u>ANT</u>	<u>ASC</u>	<u>PRE</u>
Fixed Discriminator	36	36	-	36	36	24
Tunable Discriminator	12	4	5	5	5	2
D/A Converter	9	1	-	1	1	1
A/D Converter	2	1	-	1	1	1
Computer Formatter	2	-	-	-	-	-
Data Corrector	1	-	-	-	-	-
MATES	1	-	-	-	-	-
Oscillographic Recorder	32	1	-	1	1	3
Pen Recorder	13	3	-	2	1	2
Digital Bargraph	5	1	-	1	1	1
Digital Display Unit	4	-	-	-	-	-
RTTDS Central	1	-	-	-	-	-
RTTDS Terminal	-	1	-	1	1	-

TELEMETRY

ANTENNAS

TAA-2

The TAA-2 is an 85-ft parabolic auto-tracking antenna. The RF preamplification and distribution system permits simultaneous signal reception in any two frequency bands, with polarization diversity in both bands. RF preamplifier frequencies and noise figures are as follows: 130-140 MHz, 2.5 db; 225-260 MHz, 3.5 db; 370-410 MHz, 6 db; 920-965 MHz, 7.5 db; and 2200-2300 MHz, 4.2 db.

Specifications

Gain: 31 db at 225 MHz, 49 db at 2300 MHz

Polarization: Right and left circular

Frequency band: 130-2300 MHz

Mounting: Elevation over azimuth

Preamplifier gain: 20 db min. at 225-260 MHz; 30 db min. at 2200-2300 MHz

Conical scan: 10 Hz

S-band down conversion frequency: 300-400 MHz

Tracking: Velocity -10 deg/sec; Acceleration -5 deg/sec/sec

Pointing accuracy: ± 0.10 deg plus 0.05 deg per (deg/sec)

TAA-3

The TAA-3 is a 30-ft parabolic autotracking antenna. The RF preamplification system provides signal reception and polarization diversity at S-band frequencies. RF preamplifier noise figure is 2.0 db max. in the 2200-2300 MHz frequency band.

Specifications

Gain: 43 db at 2300 MHz

Polarization: Right and left circular

Frequency band: 2200 to 2300 MHz

Mounting: Elevation over azimuth

Preamplifier gain: 17 db paramp
followed by 25 db
tunnel diode

Conical scan: 10 Hz

Tracking: Velocity - 15 deg/sec
azimuth and elevation
Acceleration -7 deg/sec/
sec azimuth and elevation

S-band down conversion freq:
300-400 MHz

Pointing accuracy:
 ± 0.10 deg plus 0.05 deg per (deg/sec)

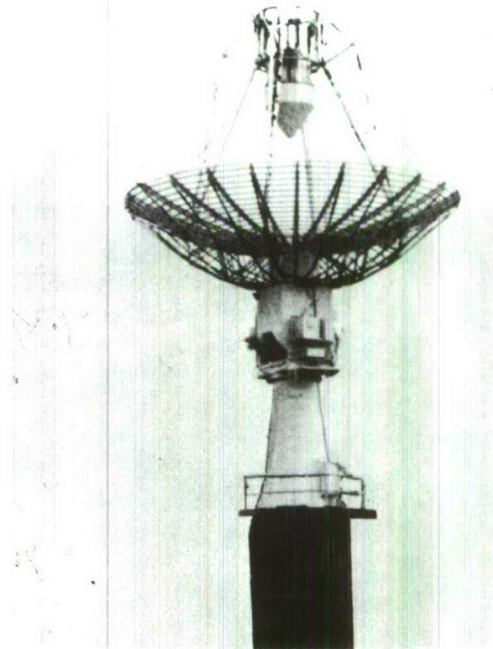

TAA-3

TELEMETRY

TAA-3A

The TAA-3A is a 33 ft parabolic autotracking antenna. The RF preamplification and distribution system permits simultaneous signal reception in any two frequency bands with polarization diversity in both bands. RF preamplifier frequencies and noise figures are as follows:

Frequency (MHz)	225-260	285-315	370-410	920-965	2200-2300
Noise Fig. (db)	3.5	4.5	4.5	4.0	4.2

Specifications

Gain: 22 db at 225 MHz, 40 db at 2300 MHz.

Polarization: Right and left circular.

Frequency band: 225-2300 MHz.

Mounting: Elevation over azimuth.

Conical scan rate: 10 Hz.

S-band down conversion frequency: 300-400 MHz.

Tracking: Velocity: 15 deg/sec, Acceleration: 7 deg/sec/sec.

Pointing accuracy: ± 0.10 deg ± 0.03 deg per (deg/sec)

Preamplifier gain: 28 db min

AT-36

The AT-36 is a 60 ft parabolic antenna capable of automatically tracking RF signals within the 130-2300 MHz telemetry band.

A nutating dual conical feed provides a conical scan system for automatic tracking of RF signals at all polarizations.

Dual reception, amplification, and detection capabilities permit diversity combining of frequency or polarization.

Specifications

Gain: 29 db @ 225 MHz, 43 db @ 2300 MHz

Frequency band: 130-2300 MHz

Mounting: Elevation over azimuth

Preamplifier gain: 20 db

Conical scan: 10 Hz

Tracking: Velocity - 10 deg/sec azimuth and elevation

Acceleration - 5 deg/sec/sec azimuth and elevation

Preamplifier Noise Figures:

Frequency (MHz)	130-140	225-260	285-315	370-410	920-965	2200-2300
Noise Fig. (db)	2.4	3.5	5.0	6.0	8.5	4.2

TAM-1

The TAM-1 broadbeam antenna, used for prelaunch support, receives both right and left circularly polarized signals (selectable as desired). The RF preamplification and distribution system permits simultaneous reception of all bands in the 130 to 2300 MHz frequency range. RF preamplifier frequencies and noise figures are as follows:

FREQUENCY (MHz)	130-140	225-260	285-315	370-410	920-965
NOISE FIG. (db)	3.5	4	5	6	8
FREQUENCY (MHz)	1435-1535	2200-2300			
NOISE FIG. (db)	4	4			

Specifications

Gain: 12 db in all bands
 Beamwidth: Approx. 40 deg all bands
 Polarization: Right and left circular
 Frequency bands: 130 to 2300 MHz,
 in discrete steps as above
 Manual tracking in azimuth only for
 pad checkout
 Preamplifier gain: 20 db

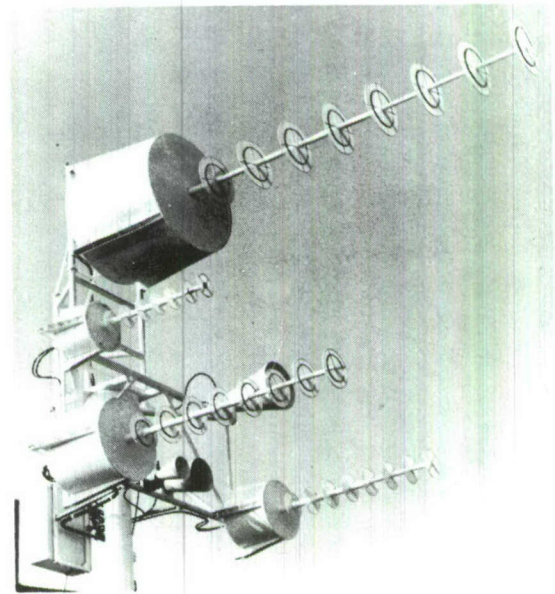

TAM-1

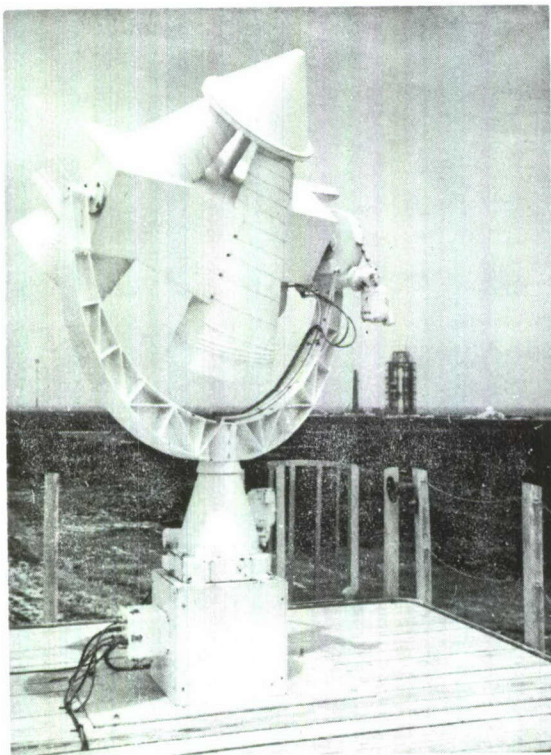

LOG PERIODIC ANTENNA

Log Periodic

The log periodic antenna is a four-element array of conical spirals for VHF coverage, with either a 2-ft or a 3-ft dish on top of the array for S-band reception. This assembly is designed to be mounted on a Houston-Fearless Model RCP-6 yoke pedestal for remote steering (Manual).

Specifications

Gain: 8 db at 136 MHz
 10 db at 230 MHz
 20 db at 2200 MHz
 Polarization: Right circular
 Slew rate: 10 deg/sec azimuth and
 elevation

TELEMETRY

TAA-8/8A

The TAA-8/8A is an 80-ft parabolic autotracking antenna system. These systems will be installed and ready for use in early 1969 at Antigua and Grand Turk. The TAA-8 is an S-band only antenna system to be located at Grand Turk. The TAA-8A to be located at Antigua is identical except that a P-band capability, is included in addition to the S-band capability.

Specifications

Gain: 31 db at 225 MHz (Antigua system only)
53.0 db at 2200 MHz

Polarization: Right and left circular

Frequency band: 225-260 MHz (Antigua system only)
2200-2300 MHz

Mount type: Elevation over azimuth

Receiving system noise figure: 4.0 db max at 225 MHz
1.6 db max at 2200 MHz

Preamplifier gain: 28 db min at 225 MHz
30 db min at 2200 MHz

Pseudo conical scan rate: 97 Hz

S-band down conversion frequency: 300-400 MHz

Tracking: Velocity - 10 deg/sec
Acceleration - 5 deg/sec/sec

Pointing error: 0.1 deg rms max at velocities up to
5 deg/sec and acceleration up to
3 deg/sec/sec

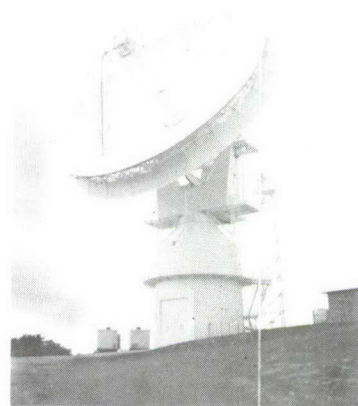

RECEIVE/RECORD

Telemetry Receiver/Recorder Group (TRKI-12)

The receiver/recorder group of the telemetry system (TRKI-12) is a complete electronic assembly designed to receive and record predetected and detected telemetry signals. The telemetry data receiver consists of three major chassis:

- (1) RF preselector/first converter
- (2) Second IF amplifier/demodulator
- (3) Video amplifier

The primary features and capabilities of the receiver are the following:

- (1) The receiver provides reception of FM, PM, or AM modulated carriers and demodulation of FM, PDM, PAM, SSBAM, PM, and PSK information.
- (2) The receiver is a dual IF channel, double-conversion, super-heterodyne receiver capable of receiving RF frequencies in four discrete bands (selectable by four plug-in RF tuners) as follows:

105 MHz to 140 MHz
216 MHz to 260 MHz
285 MHz to 410 MHz
920 MHz to 965 MHz

- (3) Bandwidths of both IF/demodulator channels are selectable by plug-in second IF assemblies from 2.5 kHz to 3.3 MHz.

The receiver area equipment includes six identical racks (each containing two VHF/UHF receivers), a dual channel spectrum display unit, a diversity combiner, a dual channel predetection converter (used with up or down converter plug-in units), and a local receiver patch panel. For the support of this equipment, a dual-trace oscilloscope, an electronic counter, and an rms voltmeter are provided.

The recorder area equipment includes one FM record/reproduce electronics assembly (with 6-channel record, 2-channel reproduce capacity and calibrating equipment), two 7/14 channel magnetic tape recorder/reproducers (AMR-FR-1400), two dual-channel predetection converters (used with up or down converter plug-in units), one 20-channel data insertion converter, one single-channel data insertion converter calibrator, two 8-channel direct write recorders, 20 distribution amplifiers, and one video/IF distribution panel. For the support of

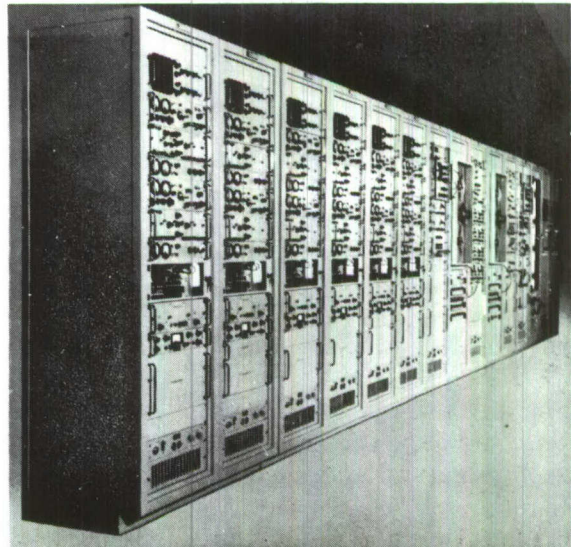

TRKI-12

TELEMETRY

this equipment, a frequency response generator, a dual-trace oscilloscope, an electronic counter, an rms voltmeter, a video spectrum display unit, a square-wave generator, and a sine-wave generator are provided.

Recording data characteristics are:

<u>Recorder Speed</u>	<u>Video Carrier</u>	<u>Predetection Freq Range to be Recorded</u>	<u>FM Record Data BW</u>
120 ips	800 kHz	100 - 1500 kHz	NA
120 ips	900 kHz	300 - 1500 kHz	dc-500 kHz
60 ips	450 kHz	150 - 750 kHz	dc-250 kHz
30 ips	225 kHz	75 - 375 kHz	dc-125 kHz
15 ips	112.5 kHz	37.5 - 187.5 kHz	dc- 62.5 kHz

Tape Playback Subsystem TDM-1

The TDM-1 subsystem will play back tape recordings of predetected and post-detected data for the data separation station and tape copy subsystem that have been received and recorded by the predetection receiver/recorder group.

Translation and demodulation of the recorded predetection data is accomplished by the predetection playback and demodulation unit. FM reproduce electronics is provided for playback of postdetected signals. These units consist of plug-ins which are identical to those in the receiver/recorder group (TRKI-12). The TDM-1 subsystem has a data time base expansion of 8:1 for predetection (IF) and FM record data.

The major components are: two-track recorder/reproducer AMR-FR 1400, eight predetection playback and demodulation units, six FM reproduce channels, calibration, system monitoring, and distribution units.

Tape Copy Subsystem TMM-7

The TMM-7 subsystem provides the Range User multiple copies of all the primary telemetry data from the various stations. Up to three copies at a time of predetected or postdetected FM data can be recorded directly within the subsystem or four copies using the tape playback subsystem of the TRKI-12. The major components are: four 7/14 track magnetic tape recorder/reproducers, seven FM record electronics, two FM reproduce electronics, and calibration and distribution units.

Remote Signal Recorder Subsystem TKM-1

The TKM-1 subsystem can record predetected or postdetected telemetry signals transmitted via a communication link from remote acquisition sites to the Tel-4 station. This subsystem consists of three 7/14-track magnetic tape recorder/reproducer AMR FR-1400 with FM record and FM reproduce electronics, signal distribution, and signal monitoring facilities.

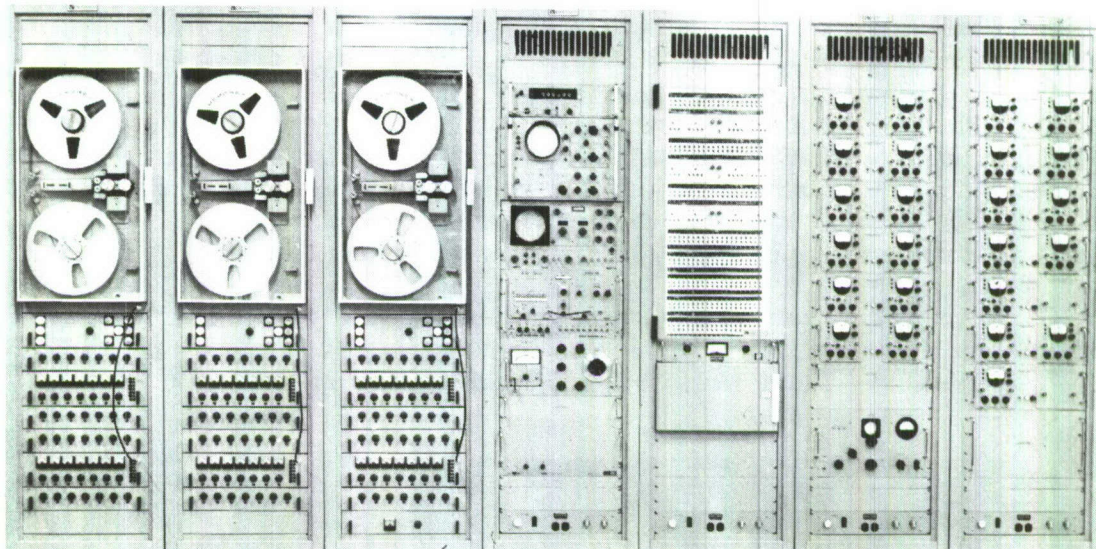

REMOTE SIGNAL RECORDER SUBSYSTEM

TELEMETRY

Post-Detection Tape Copy Station

The Post-Detection Tape Copy Station is an integrated system capable of multiple magnetic tape copying of post-detection telemetry data. The system contains six Mincom M-32 intermediate band recorder/reproducers. Five copies from a master tape, two copies each from two master tapes, or six copies from an external source may be made simultaneously.

Control logic circuits provide for simultaneous operation of all recorders or for individually selected ones from a central control panel. Signal routing within the system is controlled at a central patch panel to enable checkout and setup of individual components for various operations. Calibration, setup, and monitoring equipment, switchable between tape channels and between recorders, is included to monitor data quality, and is a permanent part of the station. These include two subcarrier spectrum display units, a dual-trace oscilloscope, two broad-band spectrum analyzers, a wave analyzer, and a band-switching discriminator. Additional test and setup equipment contained in the station include an rms voltmeter, function generator, sweep generator, bulk tape degausser, and seven signal distribution amplifiers.

Each of the six recorder/reproducers contained in the system is a 1/2-inch, 7-track machine with seven channels of direct record/reproduce electronics. The recorders are classified as IRIG compatible intermediate band machines.

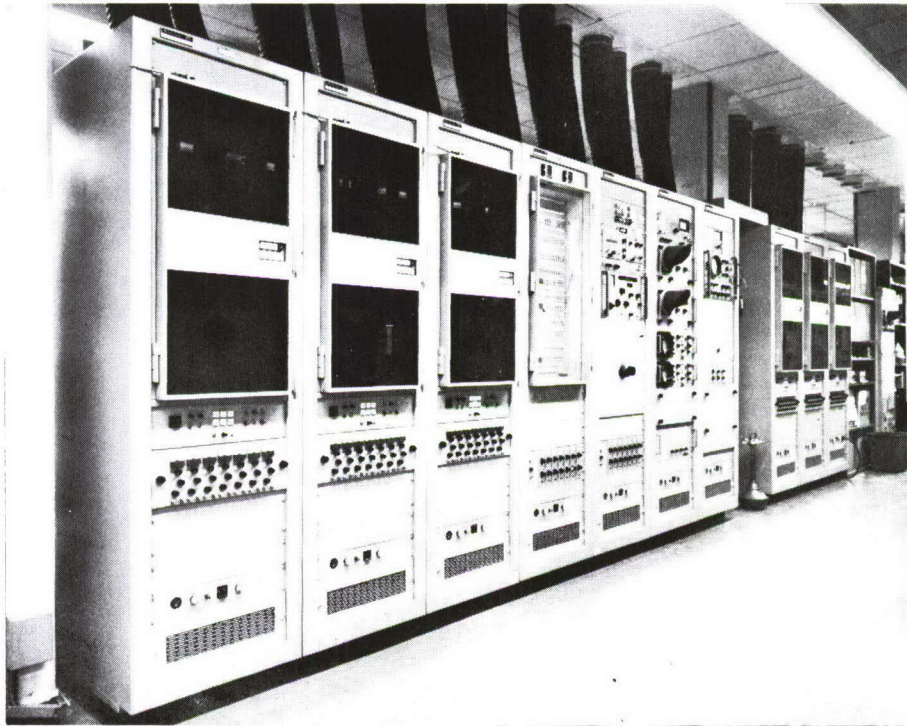

POST DETECTION TAPE COPY STATION

TELEMETRY

Signal electronics characteristics are as follows:

<u>Tape Speed (ips)</u>	<u>Data Bandwidth (± 3 db)</u>	<u>Signal-to-Noise Ratio</u>
120	370 Hz to 600 kHz	32 db
60	370 Hz to 300 kHz	30 db
30	350 Hz to 150 kHz	30 db
15	300 Hz to 75 kHz	30 db
7.5	200 Hz to 37.5 kHz	25 db
3.5	200 Hz to 18.75 kHz	25 db

TELEMETRY

DATA SEPARATION

TDM Decommutators Type I and II

The TDM (Time Division Multiplex) Decommutators accept serial data trains with most commonly used modulation schemes. Both types of TDMs can uniquely identify up to 799 words, of 3 to 64 bits per word, per frame and subframe. The TDMs can be set up manually by front panel controls and switches or by punched paper tape.

The TDM I and II have the following subsystems as components: primary synchronizer, PCM secondary synchronizer, PAM-PDM converter, and core memory decommutator.

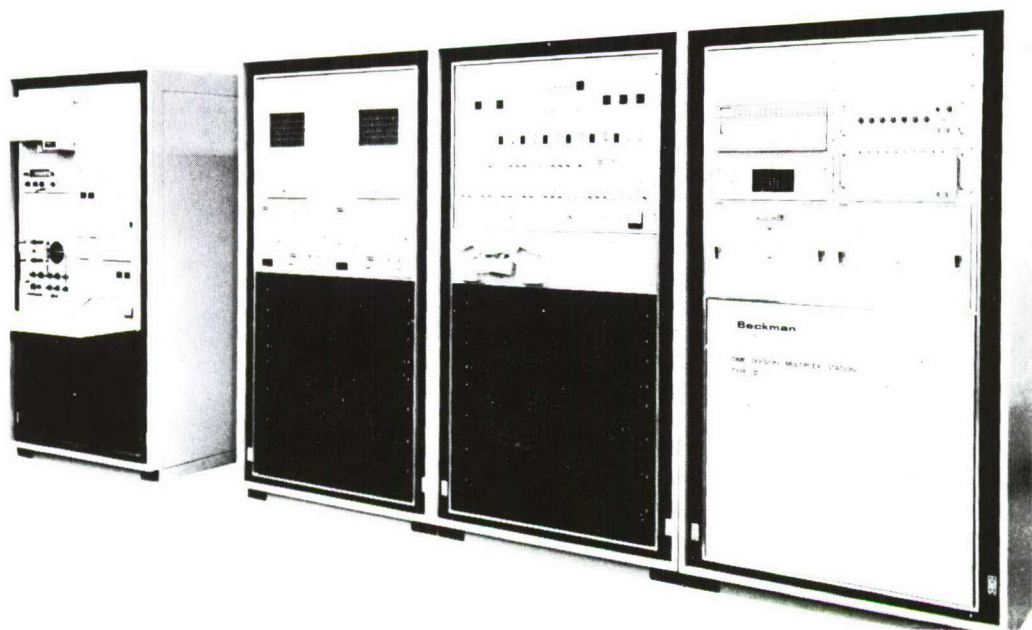

TDM-II

The primary synchronizer accepts PCM signals of NRZ, M (mark), S (space), and C (change), RZ, Bi phase L, M, S, and C. Present multicycle with ratios of 1, 2, 4, 8, 16 and 32. The incoming bit rates for NRZ codes are from 1 (-20%) to 1,000,000 ($\pm 10\%$) bps and for RZ codes rates are from 1 to 500,000 bps.

The PCM secondary synchronizer establishes word, frame, and subframe synchronizations. Word synchronization is established using search, verify, and lock logic circuitry. Two word pattern recognizers of one to three bits are **provided**. Frame synchronization is performed by two 64-bit pattern recognizers which can be used for complementary frame synchronized patterns.

Subframe synchronization can be programmed in up to six subframe patterns of 3 to 64 bits each, using search, verify, and lock for each pattern.

The PAM-PDM converter accepts various incoming signals as follows:

<u>Signal</u>	<u>Duty Cycle</u>	<u>Rates</u>
PAM-RZ	30 to 90 %	10 to 50,000 TDM II (20,000 TDM I) bps
PAM-NRZ	100 %	10 to 100,000 TDM II (40,000 TDM I) bps
PDM	Per IRIG 106-60	

The capacity of the TDM I is 799 channels in the main frame and subcommutator sequences. The capacity of the TDM II is 799 channels in the main frame. PAM synchronization can be obtained for two or three channels frame synchronization coding as described in IRIG 106-66. PAM sync can be maintained with as many as 10 pulses missing from the incoming data stream.

The core memory decommutator provides a flexible way to decommutate commutated, supercommutated, and subcommutated channels in both main and subframes.

The TDM II contains two primary synchronizers and two main frame recognizers. These provide two independent synchronizers for bit, word, and frame synchronization.

Each decommutator contains a bandswitching discriminator module capable of handling all IRIG frequencies (proportional bandwidth). A tape speed compensation system is included in each decommutator.

The TDM II also has provisions for an automatic switchover. Pre-determined data rate changes or coded control words within the transmitted data formats can be used to make the switchover.

TELEMETRY

TKDC-1

The analog TKDC-1 PCM ground station is similar to the TDM I and TDM II. The main difference is that the TKDC-1 is manually programmed by patch boards while the TDM I and II use stored programs. The TKDC-1 separates and routes the telemetry words to separate analog output points and the TDM I and II identify all words and feed them into a common language bus.

TDM Decommutator Type III

The TDM III is a relatively simple and low cost PAM/PDM decommutator which translates standard IRIG PAM/PDM signals into the ETR common language format. System characteristics are similar to the TDM I in the PAM/PDM modes except that TDM III's cannot handle PAM subcommutation.

SS/FM Demultiplexer

The SS/FM demultiplexer accepts the SS/FM complex signal output from a standard telemetry receiver and separates it into 15 individual 3-kHz data channels and a 1.2-kHz special service data channel. In addition, the demultiplexer detects any of the following abnormal conditions:

- (1) Pilot VCO not phase-locked.
- (2) Excessive noise level.
- (3) If inadequate input signal (pilot) level during any of the above conditions is detected, the output of each data channel is locked out and a level change (alarm monitor) is generated to indicate the existence of the abnormal condition.

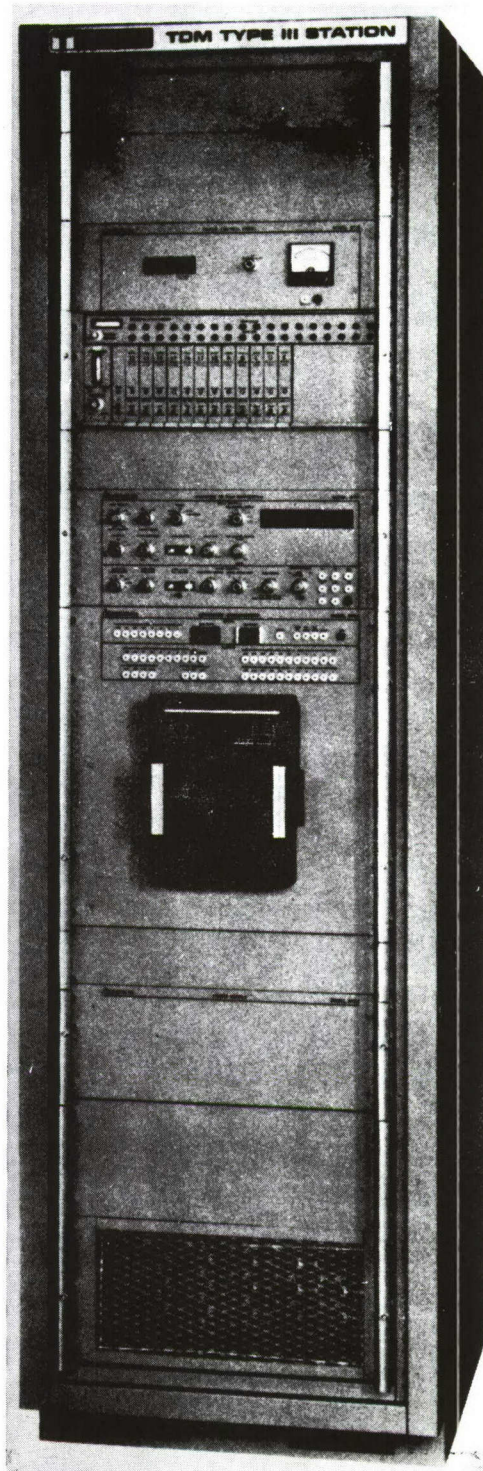

TDM-III

The Type I, SS/FM demultiplexer is supplied with a 7-track FR 1200 Ampex recorder with standard FM recorder/reproduce electronics. These seven tracks are used to record five data channels, a timing track, and the alarm monitor signal.

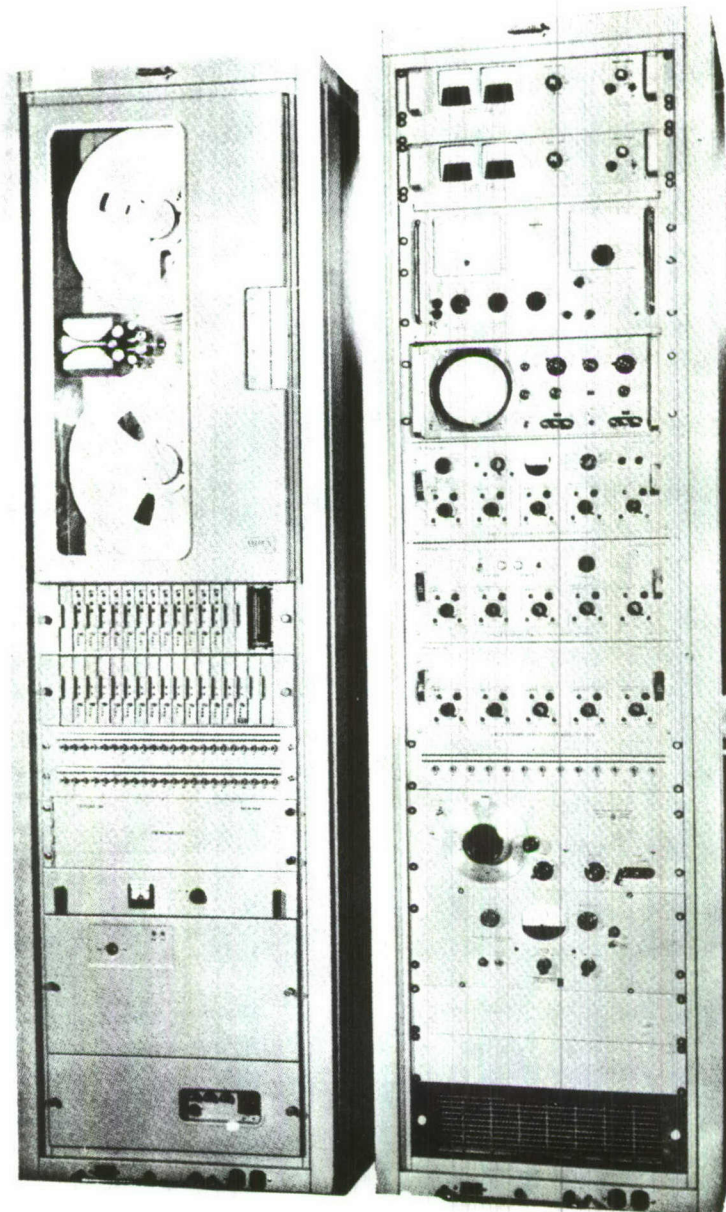

TYPE I SS/FM DEMULTIPLEXER

TELEMETRY

Fixed Discriminator System, Model 210

The Fixed Discriminator System consists of a relay rack containing six rack adapters and all necessary jack panels for test and signal distribution. Each rack adapter can accept six Model 210 plug-in discriminators with 18 units presently installed in each system. The Model 210 discriminator accepts plug-ins for channel selection and output filter characteristics. The major design specifications for the Model 210 discriminators are as follows:

- (1) Center frequency and deviation; determined by Channel Selector plug-in; available for all IRIG bands as detailed in IRIG Document 106-66. Constant bandwidth or other special channel characteristics can be accommodated by special plug-ins.
- (2) 60 db of dynamic input range.
- (3) Low pass output filters with constant amplitude or constant delay characteristics available to match channel characteristics.

Tunable Frequency Discriminator Systems

The Model 229 tunable frequency discriminator consists of a fixed frequency discriminator and a special tuning unit. The design specifications are as follows:

- (1) Tuning range: Accepts any sub-carrier channel with a center frequency from 300 Hz to 300 kHz
- (2) Subcarrier frequency deviation: $\pm 7\frac{1}{2}\%$ or $\pm 15\%$ switch selectable.
- (3) Deviation ratio: 1, 5, 10, 25, 50, and 100; switch selectable.

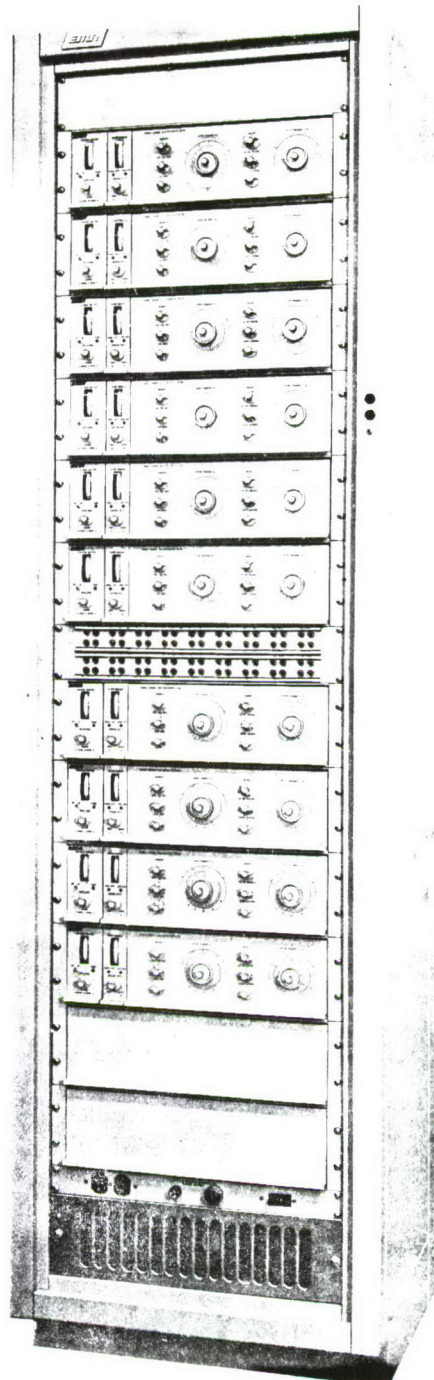

TUNABLE DISCRIMINATOR

- (4) Data frequencies: 3 Hz to 30 kHz selectable by dial and switch.
- (5) Linearity is $\pm 0.1\%$ of bandwidth for $\pm 7.5\%$ deviations and $\pm 0.2\%$ of bandwidth for $\pm 15\%$ deviations.
- (6) Output noise: The rms value of output noise is less than 0.2% of full-bandwidth voltage.
- (7) Output voltage is single ended and referenced to ground. The deviation sensitivity is negative. Gain can be controlled between ± 1 volt and ± 10 volts.
- (8) Output filter response: Switch selectable for constant phase or constant amplitude 18-db rolloff.

TELEMETRY

DATA CONVERSION

Analog-to-Digital Converter, Model 2239

The Model 2239 analog-to-digital converter accepts, normalizes, and multiplexes up to 48 bipolar analog input signals. The output is a parallel digital 10-bit word per sampled analog data. Each data word is transmitted with a 5μ sec clock pulse and a BCD 7-bit channel address (common language format) for use by the computer formatter, data corrector, and real time telemetry data system.

It has the following design features:

- (1) Accepts and normalizes the individual analog inputs having full scale values ranging from ± 1 volt to ± 20 volt.
- (2) Selects data channels for multiplexing sequentially or in random fashion by means of a program patchboard with a sampling rate up to 20,000 words per second.
- (3) Samples and holds each analog signal and converts it to a 10-bit parallel word in less than 3μ sec.
- (4) Transmits each parallel data word with clock and BCD channel address in common language format at 20,000 words per second or less.

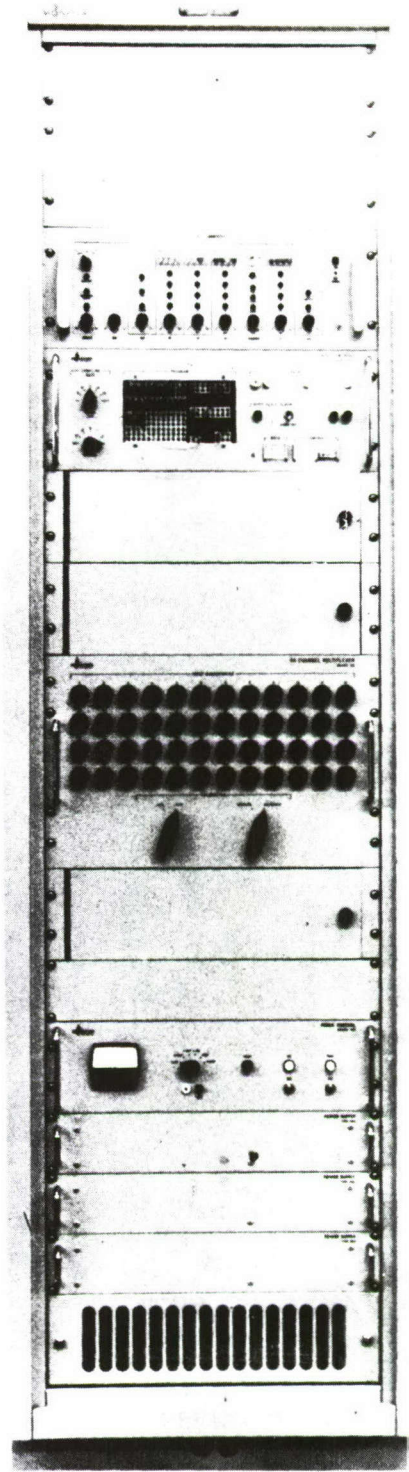

ANALOG-TO-DIGITAL (A/D)
CONVERTER

Digital-to-Analog Converter, Model 2119 and 2120

The digital-to-analog conversion system accepts up to five separate digital common language inputs for conversion to analog form for recording and display. Each digital input source may be connected to one Model 110 digital-to-analog converter group consisting of 10 each address selectors, word structure programmers, digital-to-analog converters, and analog output lines. The five Model 110 D/A groups per system provide 50 analog outputs. The Model 2119 has internal test capabilities. The Model 2120 uses an external Model 2123 test analyzer. Differing only in self-test facilities, each of these systems has the following design features:

- (1) Accepts a parallel digital data word accompanied by clock and channel address (ETR Common Language).
- (2) Selects the data word by means of front-panel thumbwheel switches which are set by the operator to the desired 3 digit channel address and, if required, 3 digit subchannel address.
- (3) Selects up to nine bits from the incoming 12-bit common language data word by means of a word structure patch board.
- (4) Converts the 9-bit word to analog form for output on one of 10 analog output channels per D/A group.

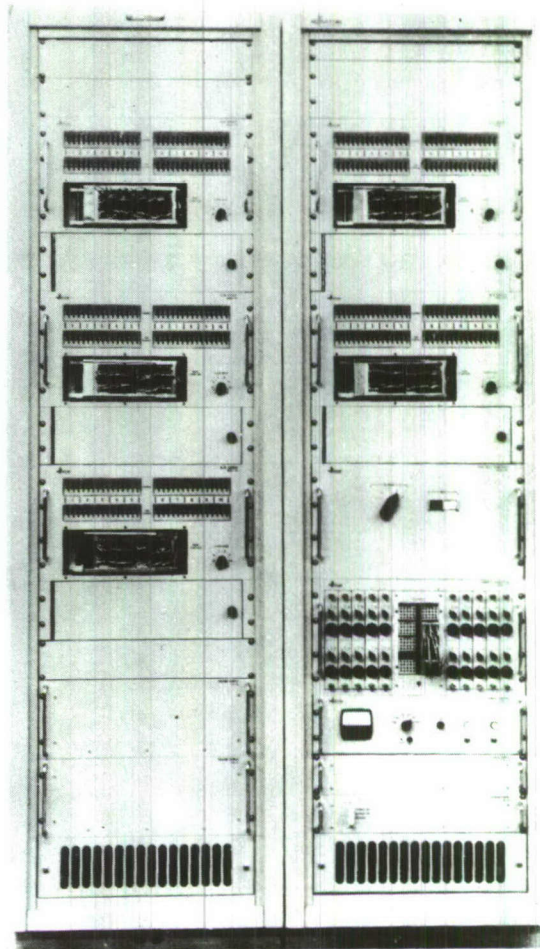

D/A CONVERTER

TELEMETRY

DATA PROCESSING (COMPUTER FORMATTER)

The Computer Formatter, in either the stored program or patchboard modes of operation, accepts common language input data with time and stores this information on magnetic tape in a computer compatible format.

The Computer Formatter can edit channels, delete out-of-sync data, and flag data. The system operates in three modes: (1) all data, (2) patch program, and (3) stored program.

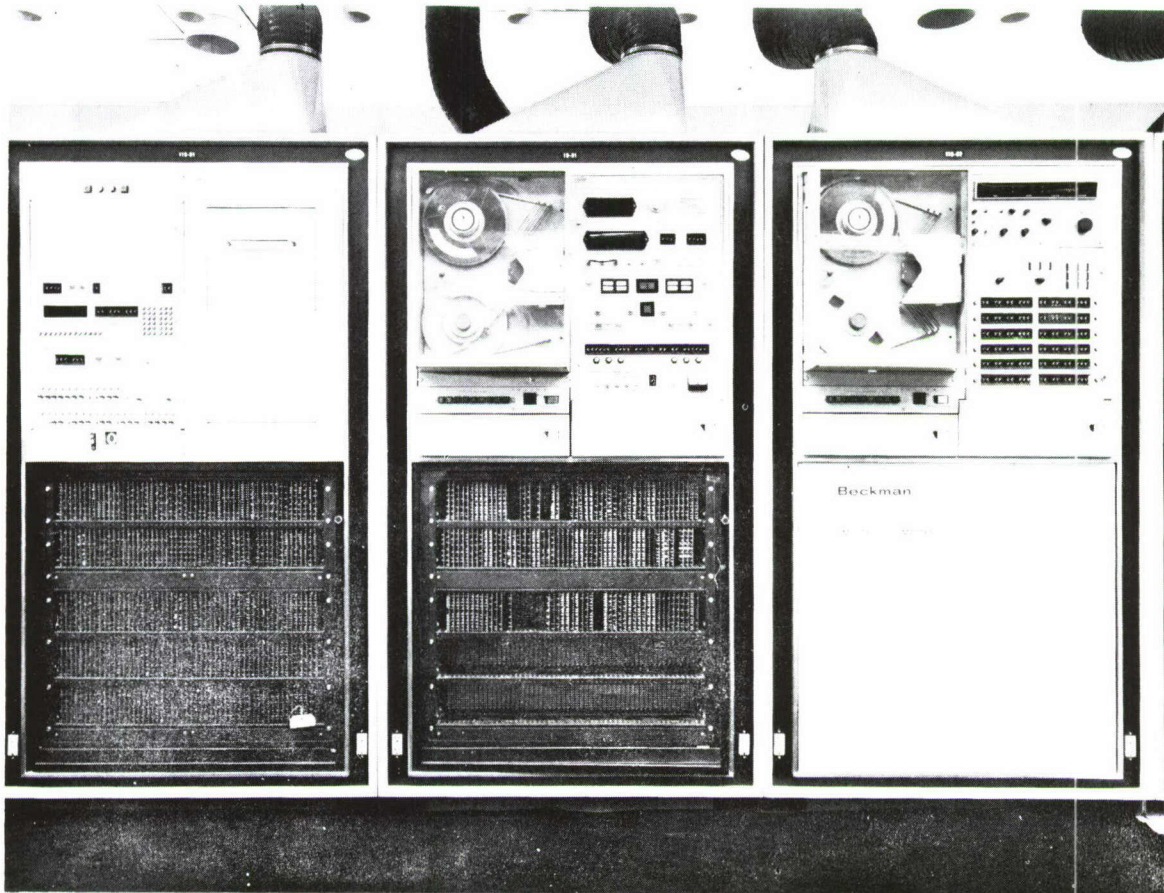

COMPUTER FORMATTER

All Data Selection

In the "all data" select mode, all incoming data is formatted onto a computer tape. Three methods of frame synchronization are provided, selectable at the option of the operator:

- (1) Channel-Subchannel Synchronization: Frame synchronization upon the coincident appearance of a designated channel and a designated subchannel, each independently selectable by thumbwheel switches from 799 channels and 799 subchannels.
- (2) Frame Recycle Pulse Synchronization: Frame synchronization controlled by the detection of the frame recycle pulse generated by the TDM station.
- (3) Combined Synchronization: Frame synchronization upon coincident appearance of both the frame recycle pulse and the selected channel MFID/SFID. This is a combination of (1) and (2) above.

Patch Program Selection

The data selection program in the patch program mode can select any combination of 512 channels or subchannels for incorporation onto a computer tape. The patch program is incorporated in the patch panel. Provisions have been made for patching the memory load control so that the data can be packed into the 36 bits, however the programmer desires. Any one or any combination of formats and groups can be used. Synchronization is patchable in this mode. Any subframe ID or any channel ID can be used as a start signal. Either Program Continue or Data Delete can be selected. If Program Continue is selected, the computer formatter buffer will format all programmed data and truncate when the TDM re-acquires from an out-of-sync condition. Data Delete will delete all the out-of-sync data and only terminate when programmed.

Stored Program Selection

The data selection program in the stored program mode can select any combination of 512 channels or subchannels to be incorporated onto a computer tape. Either the Delete Data or Program Continue mode can be chosen in this mode and will operate as above.

Frame, subframe, and word sync error flags are presented on the patchboard to be inserted into a computer word.

Three parities, parity checks, and error flags are provided for the following: (1) common language, (2) flight data words, and (3) composite computer words. Either flight data words or composite computer words will be exercised but not simultaneously.

TELEMETRY

Frame Channel Separator and Memory

The Frame Channel Separator and Memory System provides efficient computer record length. The memory can:

- (1) Accept different data rates, inter-mixed word lengths or groups, and frame lengths as inputs.
- (2) Combine the data points with time identification.
- (3) Arrange all the data channels in any desired position in the computer format.

The Frame Channel Separator has a random frame selection capability from the major cycle start identification of one to 10 frames containing known sub-channels. The separator also can select every frame, second frame, fourth frame, eighth frame, or 16th frame for computer processing.

The multiple frames formatted per tape record provides a continuous recording of two or more frames of formatted data before a record gap. The number of frames formatted can be selected by thumbwheel switches.

- (1) Frame Sync Recognition
- (2) Word Sync Recognition
- (3) Sub-Frame Sync Recognition
- (4) Word per Frame Restart

Computer Format Converter

The Computer Format Converter provides a compatible selected-format for the computer tapes. The converter can program data entry tapes at 200 and 556 bits/inch packing densities. The parity check is patchable to provide for all modes. The parity check and the parity bit insertion is included for both lateral and longitudinal positions on the tape. A parity check is made on the output tape during preparation of the recording.

The tape format generation for computer entry includes all requirements for the maximum efficiency in computer entry including tape gaps, stop marks, and/or file marks and data control marks.

The system can format nine 36-bit computer words of different data word composition and two 36-bit computer words of different time word composition. Variable input words from 4 to 64 bits can be integrated into the nine computer words.

IBM Format Recorders

Two magnetic tape recorders are provided for recording IBM format tapes. The recorders provide packing densities of 200 and 556 bits/inch. The recording speeds, and the recorder stop and start times are chosen for maximum time efficiency and continuous operation in the production of a computer tape. The recorders operate in five modes:

- (1) Continuous recording
- (2) Parallel recording
- (3) Tape copying
- (4) Single recorder operation
- (5) Overlap recording

The recorders operate alternately to provide continuous recording of data. All required command signals are provided for this operation. A selectable number of overlap records is available. In the copy mode, the data on one tape is copied onto the second tape of the formatter.

Range Time Decoder

The range time decoder provides time words for correlation of the data on the computer tape to within 1 msec. In addition, the decoder may be used for time search of the input tape and visual time display. The decoder supplies decimal readout in days, hours, minutes, seconds, and milliseconds from the 100/1000 pps range time code generator. A time control delays the seconds time change-over from ± 50 msec and 1-msec increments.

The decoded range time is recorded on the computer tape, in one or more computer words, in any position in the record. The decoded range time is recorded at a recurrent rate to provide accurate time correlation of the data on the computer tape to within 1 msec for forward and reverse time. The time readout can be correlated with any word in the data record recorded on the computer tape.

The time decoder provides a new decoded time word at the detection of the leading edge of the range time markers.

Tape Start and Stop Time Selection Controls

The Selection Control is provided for the pre-selection of recording time interval referenced to recorded range time for the processing of a computer tape. The time selection switches for determining the recording time interval are compatible with the time display. Six sets of switches are provided for selecting the automatic starting time of the recording interval and six sets for determining the automatic stopping of the recording interval for both forward and reverse time recording. An end-of-file is provided after each time period selected.

TELEMETRY

Identification Control

Two methods are provided to enter identification data onto the computer tape. The first is a series of thumbwheel switches arranged in groups as follows: Identifying data/6-characters, run number/4-characters, reel number/2-characters, recording location/2-characters, primary recording device/2-characters, secondary recording device/2-characters, and special identifications/6-characters. The second method is a paper tape entry in which all of the above identification data plus complete channel identification can be provided. ID entry on tape does not preclude the recording of data records only.

Computer Tape Time Placement

The time word reference for the computer tape can be integrated into the computer tape format in any desired position to provide complete time correlation of the data with all possible conditions of frame stripping.

Additional Capability

The range unit addition to the ETR Range Time provides the capability of handling IRIG 104-60 formats A and B. The BCD format is used for display. Both the BCD format and binary format are used for the computer record.

Range Time Input

Patch facilities are provided for receiving various time codes from four input lines. The range time input impedance is 10K ohms. The input voltage is 5 volts peak-to-peak.

DATA CORRECTION (DATA CORRECTOR SYSTEM)

The Data Corrector System performs real-time operations on telemetry data. Depending upon the particular program (software) used, either on-line or off-line digital operations may be performed by the Data Corrector. Primary on-line operations consist of receiving real-time telemetry data (common language format), editing and correcting this data, and producing outputs for the display and mission control. Data and other information may also be recorded on magnetic tape for postmission analysis. Off line, the Data Corrector may be used to perform many general purpose computer functions: assemble and check out its own programs, generate programs for other stored program telemetry equipment such as the TDM I and TDM II, check and dump computer formatter tapes, etc.

Communication with other telemetry equipment is carried out in real time through its Common Language (CL) interface. The heart of the Data Corrector System is a small-scale solid-state general purpose digital computer (Beckman Model 420) having an 18-bit word length, and a memory capacity of 16,384 words. There are two standard input/output channels, and a third high speed input channel (DME) which utilizes the direct memory access feature of the computer. Peripheral devices include a card reader, a line printer, a high speed code converter, and a magnetic tape unit.

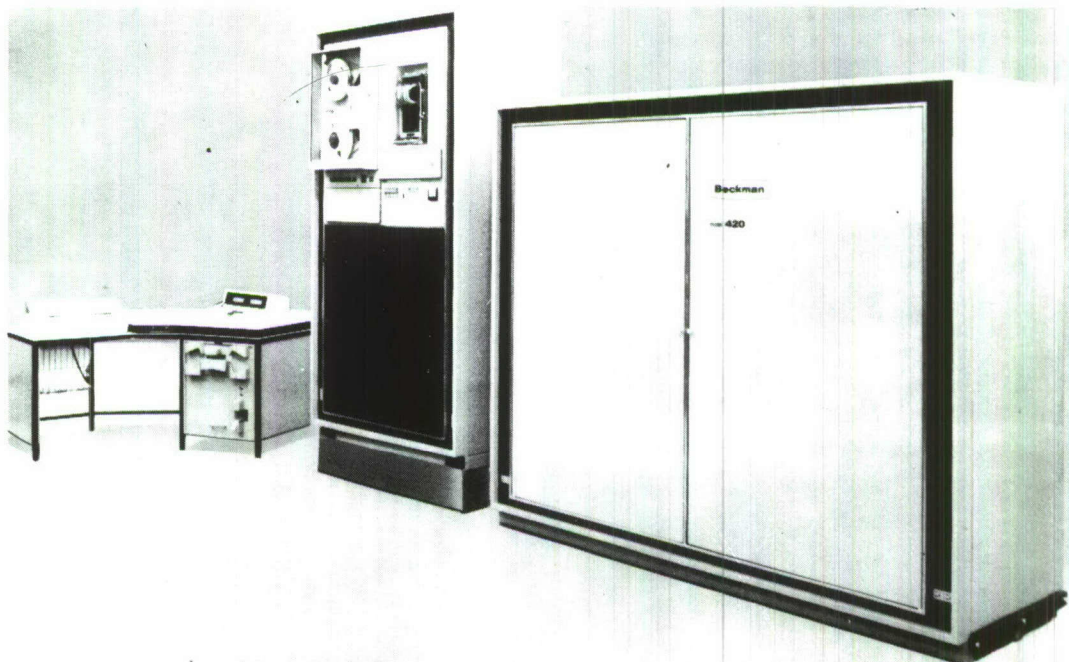

DATA CORRECTOR

TELEMETRY

DATA DISPLAY

Oscillographic Recorders

The primary oscillographic recorders used on the Range are Honeywell 1612s. These machines make permanent recordings for distribution to the range user. They have the following design specifications:

- (1) Provide 17 data and a timing channel on one paper strip.
- (2) Frequency response is from dc to 5 kHz (with special HF galvanometers, dc to 13 kHz).
- (3) Fifteen chart speeds from 0.1 ips to 160 ips.
- (4) Quick identification of traces is provided by interruption of galvanometer light beams.

Pen Recorders

The Brush Mk 200 recorders on the Range have essentially the same configuration. The design details are as follows:

- (1) Provide 16 channels of low frequency data recording plus timing to be made on two separate chart rolls.
- (2) Provide separate timing inputs to be displayed on right side, left side, or both sides through separate marker amplifiers.
- (3) Provide chart speeds from 0.002 ips to 8 ips in 12 steps.
- (4) Provisions are made to remotely control the recorder if required.
- (5) Twenty-five line calibration check provides an internally

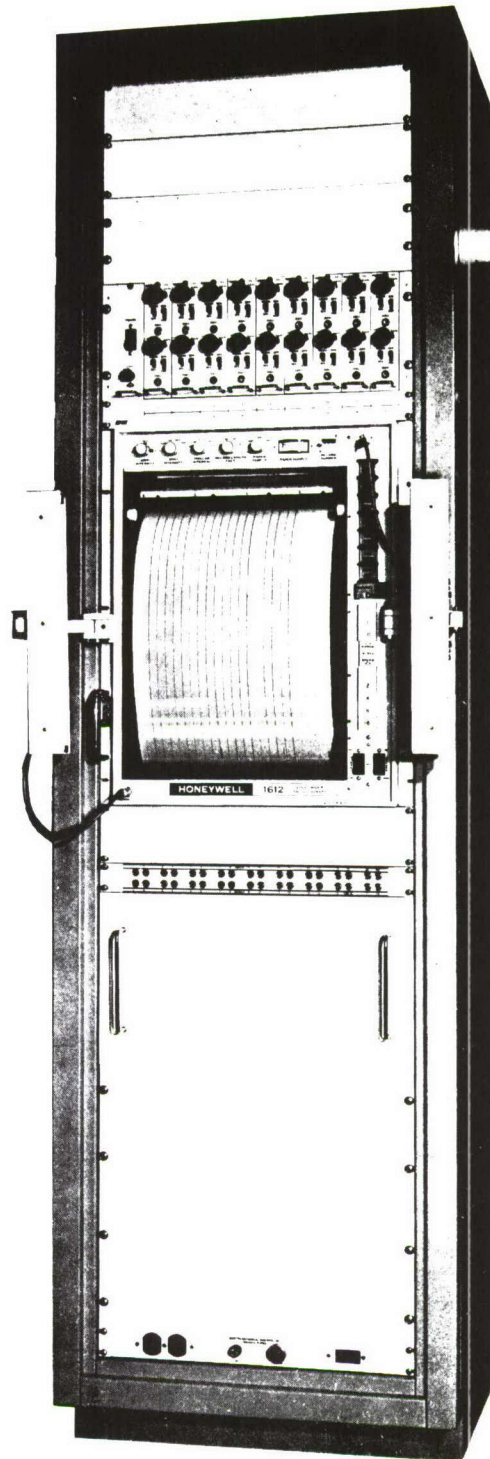

OSCILLOGRAPHIC RECORDER.

generated 0.1% reference voltage to the pens for calibration.

- (6) Handle data amplitudes from ± 1 volt to ± 20 volts.

Analog Bar Graph, Model 2422

The analog bar graph converts continuous analog telemetry and instrumentation data from up to 40 sources to a form suitable for application to a large-screen oscilloscope for a bar type display. The design features are as follows:

- (1) Accepts up to 40 bipolar analog inputs up to 2 kHz with various full scale values (± 1.3 volts to ± 20 volts).
- (2) Programs inputs to desired channels by means of a shielded patchboard.
- (3) Normalizes inputs to common full-scale range.
- (4) Multiplexes inputs by means of 40 selectively enabled electronic switches to obtain samples of all inputs in time sequence.
- (5) Adjusts frame length to display 10, 20, 30, or 40 channels.

Digital Bar-Graph, Model 2321

The digital bar-graph display provides an analog display of up to 40 channels stripped from the common language signal. The design features are as follows:

- (1) Converts variable-length digital data to a form suitable for bar graph display.
- (2) Accepts PCM telemetry data and channel addresses in RZ or NRZ bit-parallel word-serial

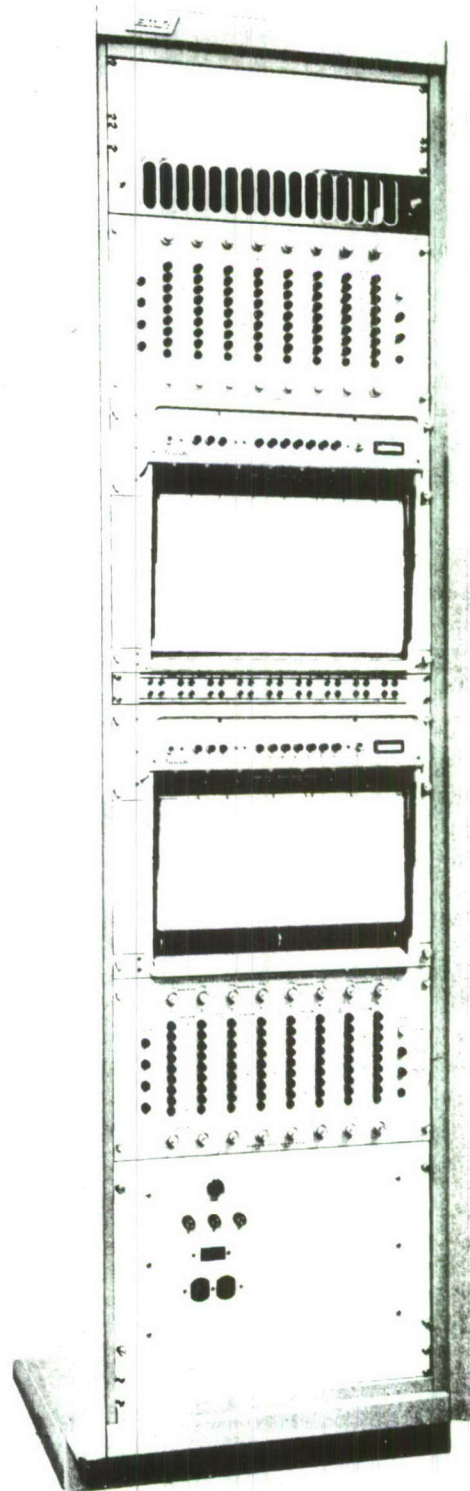

PEN RECORDER

TELEMETRY

form at word rates to 100-kHz from one of eight switch-selected sources.

- (3) Selects channels to be displayed by thumb-wheel switch indicating channel and subchannel.
- (4) Normalizes inputs to provide full scale bar heights regardless of input word length.
- (5) Adjusts frame length to display either 10, 20, 30, or 40 channels starting from either channel 1, 11, 21, or 31.

Digital Display

The digital display unit accepts common language inputs and distributes the data to such displays as 7-digit Nixies, analog meters, event meters, multistylus event recorders, and digital printers. The Nixies and analog meters display transient signals, and the event recorders and digital printers provide a permanent record of data.

A programming selector (patch board) will select the channels to be displayed or recorded. A digital printer prints binary or binary coded decimal. A multistylus recorder provides an alternate means for displaying binary data. Alphanumeric readout devices have lamp visual displays for decimal digital data. Special alarm meters, with adjustable tolerance, monitor digital data.

Multistylus Event Recorder: A self-contained 150-channel event recording instrument manufactured by Brush Instruments. The recording units accept on-off type data signals which are recorded on permanent chart paper. One channel is used as a timing channel for accurate event timing information.

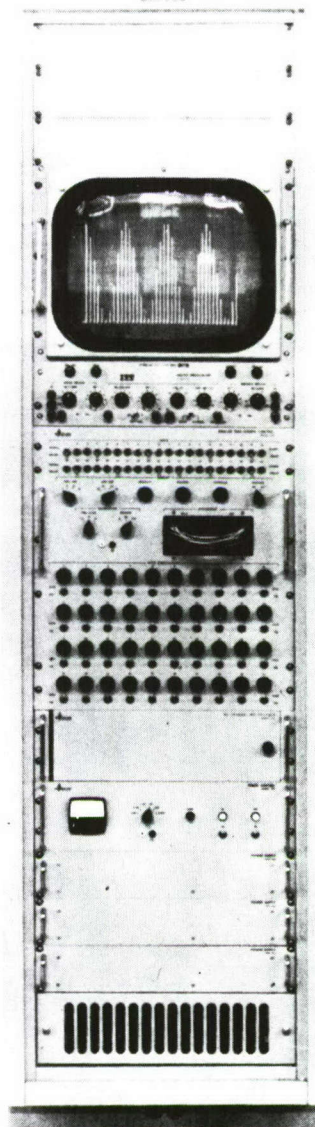

ANALOG BAR GRAPH
DISPLAY

Number of styli: 150

Response: Instant to 1.25 msec at maximum chart speed.

Chart speeds: 5, 10, 20, 50, 100 and 200 mm/sec and 0.05, 0.1, 0.2, 0.5, 1, and 2 mm/sec.

Digital Printer: This printer is a Hewlett Packard 526-A with 11 column utilizing standard code wheels. The display unit includes a binary-to-BCD converter to print either octal or decimal.

Nixie Readouts: Ten banks of 7-digit in-line displays which are single channel selectable.

Analog Meter: Ten meters with 10-volt full scale range. Separate DAC units with 9-bit binary resolution are included. Separate dividers for external inputs of 30 volts are included (the included DACs provide levels to 10 volts maximum, unipolar). Adjustable alarm limits (both high and low) on each meter energize a latching error indicator. The error light acts on an input below low limit (only), above high limit (only), or out of either limit.

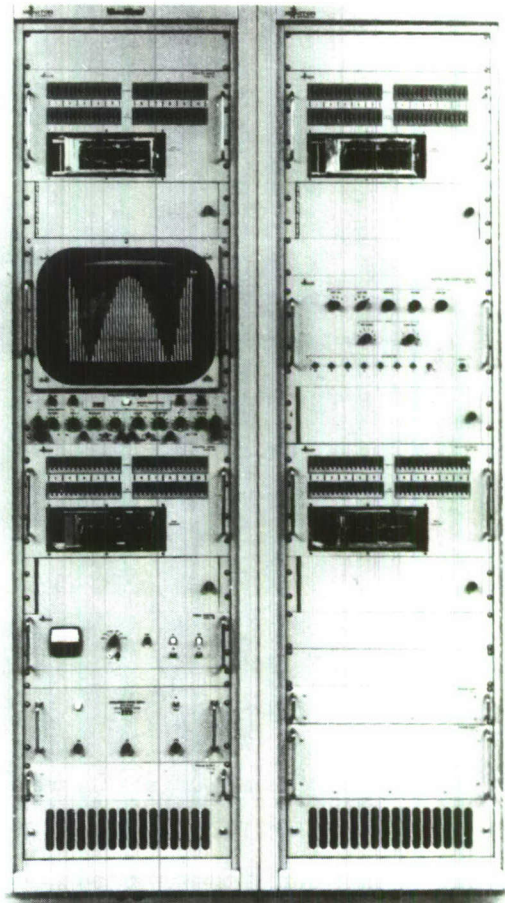

DIGITAL BAR GRAPH DISPLAY

TELEMETRY

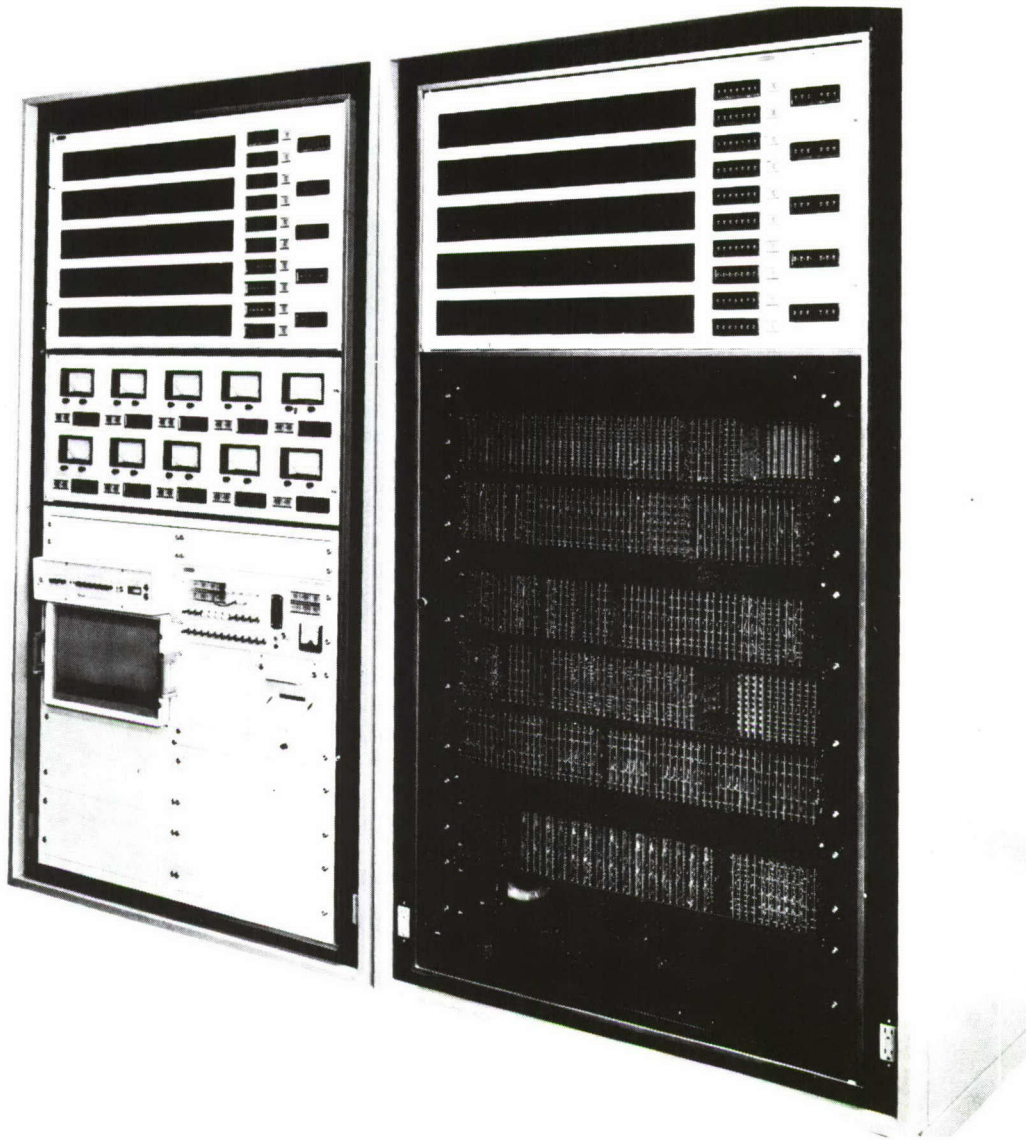

DIGITAL DISPLAY UNIT

DATA TRANSMISSION - REAL-TIME TELEMETRY DATA SYSTEM (RTTDS)

The Real-Time Telemetry Data System (RTTDS) was developed so that remotely and locally acquired telemetry data could be delivered to users in real time. To accomplish this, the RTTDS performs the following major functions:

- (1) Selects data from multiple asynchronous telemetry down links.
- (2) Formats the mixed data channels for uprange retransmission.
- (3) Decommutes the received downrange data mix at the central telemetry facility.
- (4) Selects locally acquired data to combine with remote site data.
- (5) Provides several output data formats at various word rates and channel groupings for transmission to various users.

A simplified block diagram of the system, depicting the flow of data is shown on page 91. The data inputs to the system are from multiple digital common-language (CL) sources consisting typically of time division multiplex (TDM) Type I, II, and III decommutators and analog-to-digital (A/D) conversion systems. A remote site subsystem is called a signal programmer and conditioner (SPAC). As shown in page 91 each SPAC consists of two major types of equipment: a data selector and storage buffer (DSSB) and a retransmission

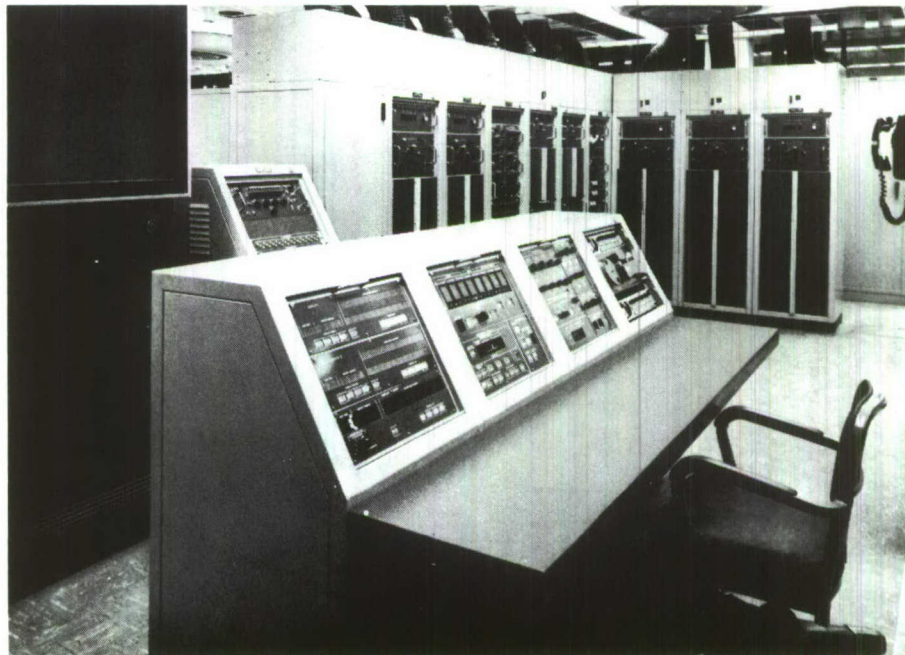

RTTDS CONSOLE AT TEL 4 SITE

TELEMETRY

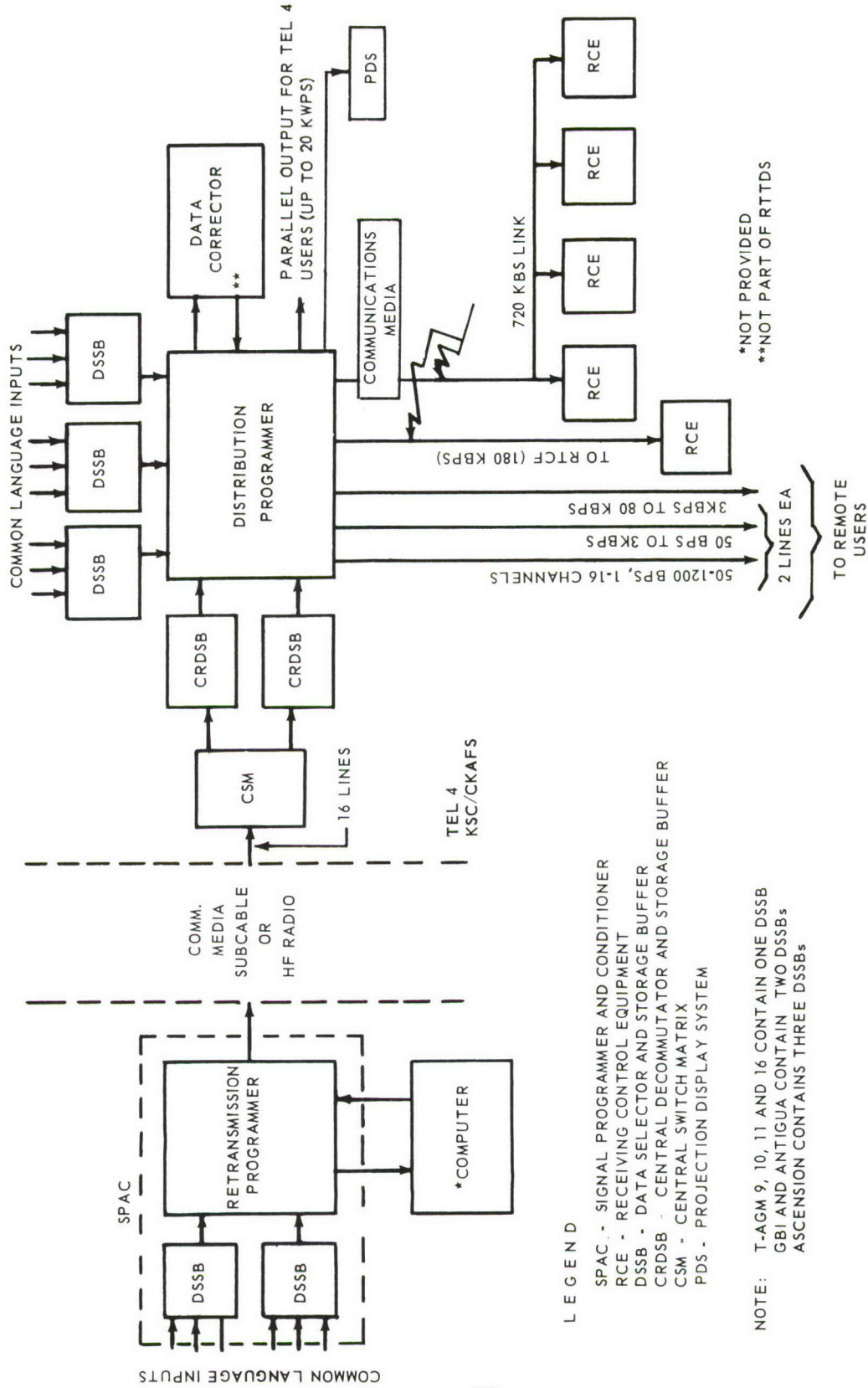

FIGURE 20. RTTDS BLOCK DIAGRAM

programmer (RP). The number of DSSBs per each SPAC can vary from one to six. The block diagram identifies the number of DSSBs installed with each SPAC. A DSSB has three CL inputs and can simultaneously accept and store data in memory, in parallel form, at asynchronous input rates up to a combined total of 100,000 wps. In addition, it can select and store a time word with each data word selected. Data word length can be from 4 to 12 bits per word.

A DSSB contains a 4096 word by 26 bit magnetic core memory where program instructions and data are stored. Since each land-based remote station has two DSSBs, it can select and store data from up to six telemetry down links (CL sources).

The RP is more complex than a DSSB and performs the task of selecting data from each DSSB memory, the programmable patch panel, and a computer (not provided), and merging this data into one output serial bit stream, the format of which is under program control. The output bit rate capability is from 25 bps up to 400 kbps. The output serial bit stream is routed into communications interface equipment (modem) where it is converted into a form suitable for transmission over a submarine cable or HF radio, whichever is applicable. The maximum bit rates from the downrange sites are: Grand Bahama - 200 kbps; Antigua - 72 kbps; all others - 2.4 kbps. The RP will handle words of mixed length (4 to 12 bits). It also has truncation capability for words over four bits long. The RP magnetic core memory system holds 4096 words of 30 bits each and contains the program instructions. The SPAC contains a program entry and control (PEC) panel which provides manual access to the RP and DSSB memories. Programs can be manually read into any of the memories and the contents of any memory location can be read out and displayed on the PEC panel. Programs are normally entered in the memories via paper tape from a tape reader which is part of the PEC. The DSSBs and RP can store an A or B program and allow changing from one to the other by merely actuating a switch. Also new programs can be read into the system while it is operating without interference to the operating program.

The Central Site equipment is comprised of a central switch matrix (CSM), two central retransmission decommutator and storage buffers (CRDSB), a distribution programmer (DP), a central control console (CCC), three DSSBs, a projection display system (PDS), an IBM tape deck, and an IBM line printer. Five receiving control equipments (RCE) are located at users' interfaces in the KSC/CKAFS area.

The serial bit streams from down range are routed to the CRDSBs via the CSM. The CRDSBs, under program control, decommutate the data and store it in known locations in their 4096 word x 32 bit magnetic core memories. The maximum serial input rate to a CRDSB is 200 kbps. The DP, under program control, selects data from the DSSBs and the CRDSBs and combines this data into one or more of several output formats and rates described below:

TELEMETRY

- (1) A high rate parallel output (up to 20,000 wps) for users within Tel 4.
- (2) A high rate serial output (up to 720 kbps) with either BCD or binary IDs for users in the KSC/CKAFS area. This link contains the same data as (1) above.
- (3) A serial output link to the Real-Time Computer System with a maximum rate of 180 kbps. RCEs are provided to the users of this output and (2) above. The RCE is essentially a serial-to-parallel converter.
- (4) A serial output which can be interfaced with a Bell 301-B or similar modem. The rate is variable from 3 kbps to 80 kbps with a fixed stop at 40.8 kbps. This link is for transmitting data to remote user locations.
- (5) Two serial output links (their data content can be different) for remote users as in (4) above. The rates are from 50 bps to 3 kbps. These links can be interfaced with Bell 201 or similar modems.
- (6) Two TTY links for providing data to remote users as in (4) above. These are 50-1200 bps links (depending on format and number of channels) and each may contain different data words.
- (7) An output to the Projection Display System. The PDS provides selective presentation of system quality assessment data and associated operational status information.

The 2400 bps maximum retransmission capability from sites and ships connected to CKAFS via HF radio is provided by the HF data modems described elsewhere in this document. The retransmission capability from the subcable sites is provided by Communications Interface System modulators and demodulators manufactured by Honeywell, Inc. These modem systems can transmit up to 72 kbps over a 48 kHz bandwidth communications circuit and up to 360 kbps over a 240 kHz circuit. In addition to handling data from a SPAC to the RTTDS Central Site and from the Central Site to a user in the KSC/CKAFS area, these modems can be used to retransmit serial bit stream data after it is regenerated by a TDM primary synchronizer at the downrange station. Modulators are currently located at GBI, GTK, and Antigua; demodulators are located at Tel 4/KSC and at the Real Time Computer System.

III
SUPPORT

COMMUNICATIONS

The Eastern Test Range operates point-to-point, air-to-ground, ship-to-shore, and intrastation communications, using undersea cable; HF radio, both AM and single sideband; VHF and UHF links; microwave; standard and wideband wire distribution; closed circuit television; automatic and manual telephones; plus an extensive data transmission and teletype network. These systems are used for voice or teletype transmission of operational and administrative traffic, transmission and reception of test data, and for transmission of missile command and destruct signals.

UNDERSEA CABLE

Coaxial undersea cables have been a most important part of ETR communications since 1954. The original cable, with land-based repeater amplifiers at 60 to 70 nm intervals, was installed by Western Electric in 1954, providing service from Cape Kennedy to Grand Turk. Service was extended to Mayaguez, Puerto Rico in 1955.

The bandwidth available (150 kHz) was multiplexed to provide 12 full duplex channels, or if desired, 12 voice channels downrange and 9 voice plus one 45-kHz data channel uprange.

In 1963, the W. E. cable between Grand Turk and Puerto Rico was replaced by the F & G (Felton & Guillaume) cable. At the same time, the F & G cable extended service to Antigua. The F & G cable is a coaxial structure of 0.660 inch o. d. with protection and strength furnished by steel armor wires spiraled around the coaxial tube. The W. E. cable is now terminated at Eleuthera.

Submerged repeaters at 17.5-nm intervals provide a passband of 240 kHz in each direction on the F & G cable, which lands only at Grand Turk; Ramey AFB, Puerto Rico; and Antigua. Group modulators and demodulators employing DCA and CCITT standard modulation plans break the 240 kHz passbands into five full duplex 48 kHz group bands at the 60 - 180 kHz frequency level. Two of the groups have AN/FCC-17 type multiplex equipment which make 24 full duplex voice channels available at the three stations (Grand Turk, Ramey, and Antigua).

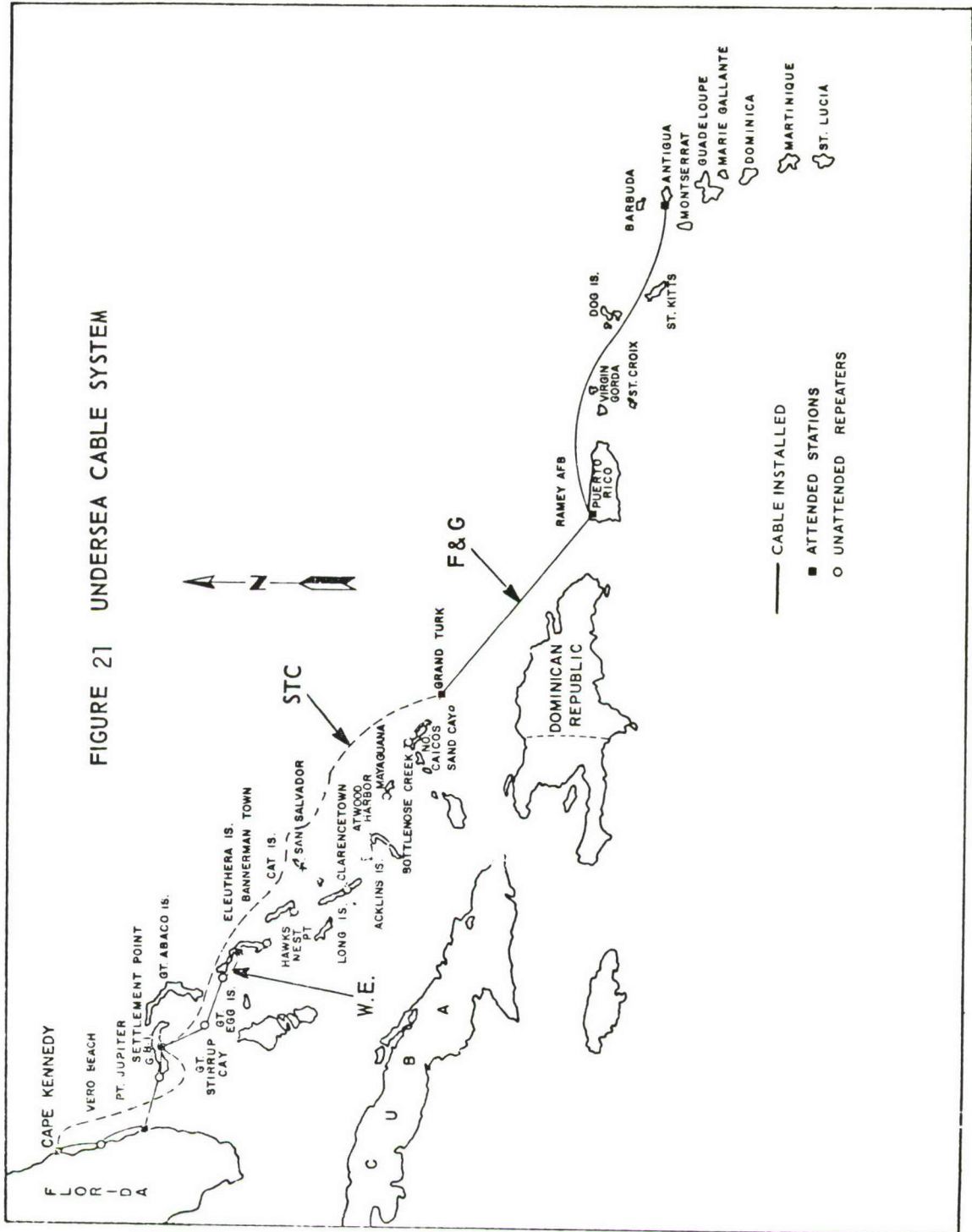

A third underwater cable system, called the STC (Standard Telephone and Cable), was put in service in March 1967. This system links Cape Kennedy, Grand Bahama, San Salvador, and Grand Turk. The STC cable is the light-weight armorless type which has the strength members incorporated in the center conductor. The coaxial tube has an o. d. of 1.00 in. ; it is protected by a 0.250 in. layer of English "Polythene" over the tube. Armor wires are used in shallow water stretches. The attenuation in the frequency range used is about one third less than 0.660-in. armored cable.

In the Grand Bahama-San Salvador-Grand Turk section the spacing between repeaters is 29.7 nm. The passband is 240 kHz in each direction and the modulation plan and voice breakout is the same as for the F & G cable.

In the Cape Kennedy-Grand Bahama link, the frequency range and passbands are much higher. The passband is 1116 kHz in each direction; with guard bands the usable bandwidth is 1080 kHz in each direction; the lowest frequency transmitted is 312 kHz and the highest is 2964 kHz. The wideband repeater amplifiers are spaced 9.7 nm apart. The chart on page 97 shows the voice and data channel capabilities of the entire system. One of the uprange 48 kHz data channels, when not needed for data transmission, will be used with a downrange 48 kHz channel to establish 12 full duplex express voice circuits between Cape Kennedy and Antigua, a total distance of about 1500 nm.

HIGH FREQUENCY RADIO

High frequency, single sideband (HF/SSB) radio, used to span long distances, provides point-to-point, ship-to-shore, and ground-to-air communications. Each HF radio link is designed to handle voice, teletype, and digital data transmissions.

Point-to-point radio links between major stations use 45-kw HF/SSB transmitters and antennas designed for day and night frequencies. Compatible receivers are used for space diversity reception of teletype traffic, voice and data. The equipment can provide 1 or 2 voice channels for each RF link, using bandwidths of 3 or 6 kHz as propagation conditions permit. Frequency range is from 2 to 30 MHz selectable in 1-kHz steps of which the ETR uses 4 to 28 MHz.

COMMUNICATIONS

MULTIPLY PLAN

STC AND F&G CABLES

1. AVAILABLE FREQUENCIES ARE DIVIDED AS FOLLOWS:
 - A. VOICE CHANNELS - 4 KHZ SEPARATION
 - B. GROUPS - 48 KHZ, EQUIVALENT TO TWELVE 4 KHZ VOICE CHANNELS.
 - C. SUPERGROUPS - 240 KHZ, EQUIVALENT TO 5 GROUPS.
2. MULTIPLEX EQUIPMENT IS TYPE AN/FCC-17, AND WILL PROVIDE:
 - A. CKAFS - GBI LINK
 - (1) 36-VOICE CHANNELS FULL DUPLEX
 - (2) 17-EA - 48 KHZ BANDS FOR BULK DATA UPRANGE, OR 1 EA - 240 KHZ BAND PLUS 12 EA 48 KHZ BANDS FOR BULK DATA UPRANGE OR 2 EA - 240 KHZ BANDS PLUS 7 EA - 48 KHZ BAND FOR BULK DATA UPRANGE OR 3 EA - 240 KHZ PLUS 2 EA 48 KHZ FOR BULK DATA UPRANGE.
 - (3) 1 EA - 48 KHZ BAND FOR BULK DATA DOWN RANGE PLUS 2 EA - 48 KHZ BANDS FOR FUTURE USE DOWNRANGE, PLUS 1 EA - 240 KHZ FOR BULK DATA DOWNRANGE

B. GBI-GTK-RAF-B-ANT LINK

- (1) 36 VOICE CHANNELS FULL DUPLEX
 - (2) 2 EA - 48 KHZ BANDS FOR BULK DATA UPRANGE
 - (3) 1 EA - 48 KHZ BAND FOR BULK DATA DOWNRANGE PLUS 2 EA - 48 KHZ BANDS FOR FUTURE USE DOWNRANGE.
3. VOICE CHANNELS MAY BE USED FOR DATA WITHIN CAPABILITY OF THEIR BAND WIDTHS AND THE CHARACTERISTICS OF THEIR CHANNEL DERIVING AND MULTIPLEX EQUIPMENT.
 4. ONE OR MORE VOICE CHANNELS WILL BE USED FOR CARRIER TELEGRAPH MULTIPLEX, CONTROL SYSTEMS SUCH AS RANGE INSTRUMENT CONTROL SYSTEM (RICS) AND WIRELINE MODEMS.
 5. INTERCONNECTIONS WITH EXISTING UNDERWATER CABLE SYSTEM WILL BE AVAILABLE AT CKAFS, GBI, AND GRAND TURK.

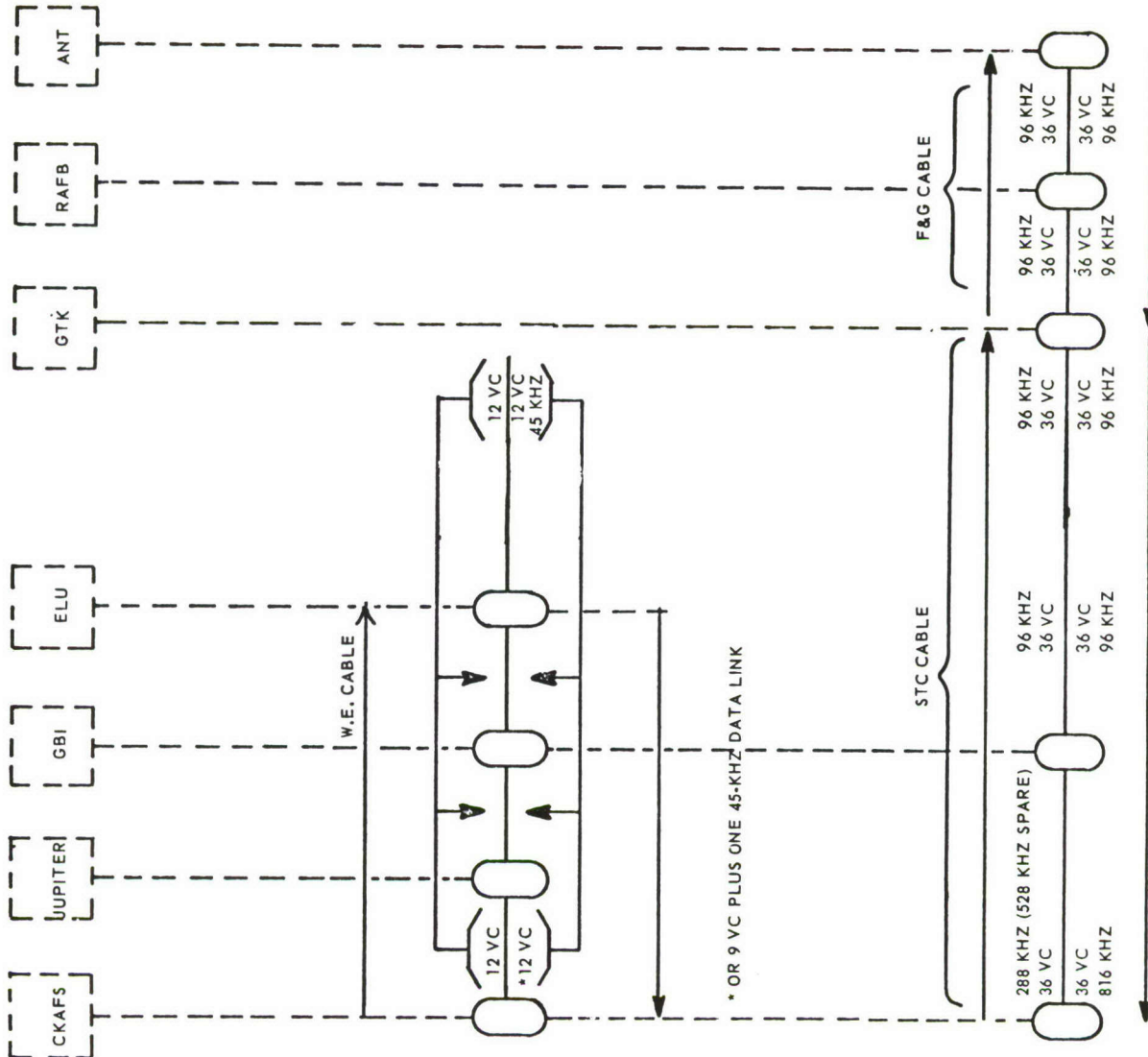

FIGURE 22 UNDERWATER CABLE SYSTEM BANDWIDTH

TABLE 2 UPRANGE TELEMETRY CHANNELS (W. E. CABLE)

IRIG TELEMETERING CHANNEL NUMBER	CENTER FREQUENCY (hertz)	MAXIMUM FREQUENCY DEVIATION		MAXIMUM SIGNALING FREQUENCY (hertz)	TOTAL BAND ALLOWANCE (hertz)	OVER-ALL DELAY DISTORTION LIMIT* (μ sec)
		(hertz)	(%)			
6	1,700	1,572 - 1,828	7.5	25	1,522 - 1,878	250
7	2,300	2,127 - 2,437	7.5	35	2,057 - 2,543	180
8	3,000	2,775 - 3,225	7.5	45	2,685 - 3,315	140
9	3,900	3,607 - 4,193	7.5	60	3,487 - 4,313	107
10	5,400	4,995 - 5,805	7.5	80	4,835 - 5,965	80
11	7,350	6,799 - 7,901	7.5	110	6,579 - 8,121	58
12	10,500	9,712 - 11,288	7.5	160	9,392 - 11,608	40
13	14,500	13,412 - 15,588	7.5	220	12,972 - 16,028	29
14	22,000	20,350 - 23,650	7.5	330	19,690 - 24,310	19
15	30,000	27,750 - 32,250	7.5	450	26,850 - 33,150	14
16	40,000	37,000 - 43,000	7.5	+	35,800 - 44,200	‡

* Loss of accuracy for the full system length must not exceed 2 percent in any channel at full speed and modulation.

+ The standard maximum signaling rate for this channel is 600 hertz but delay distortion limits are exceeded at this rate; accurate transmission can take place only at a slower rate. Noise may require use of full modulation index for high accuracy.

‡ Measured overall delay distortion in this channel is 15 μ sec which would permit a maximum signaling speed of more than 400 hertz with high accuracy, but sending up range from some intermediate point, the delay distortion may be as much as 31 μ sec which would limit accurate signaling speed to about 200 hertz.

FIGURE 23 BANDWIDTH ALLOCATION - CAPE TO Eleuthera (W. E. CABLE)

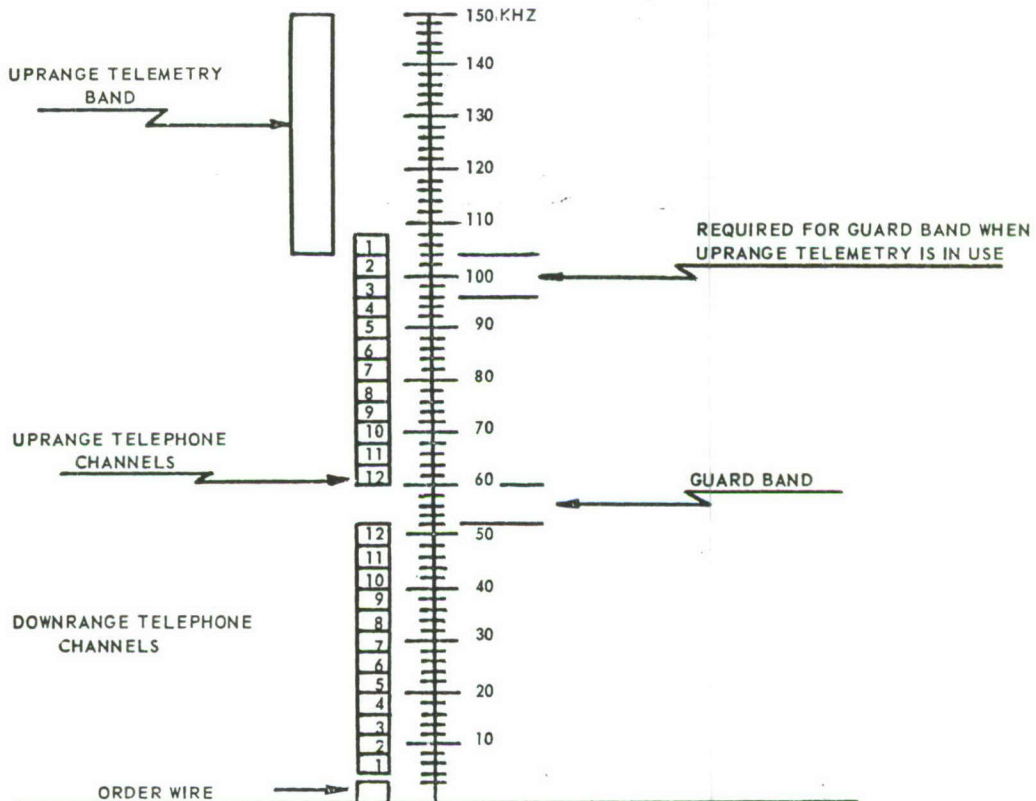

USE OF UPRANGE TELEMETRY BAND PRE-EMPTS UPRANGE TELEPHONE CHANNELS 1, 2 AND 3.

COMMUNICATIONS

High power RF links are used between:

Cape Kennedy and Antigua for undersea cable backup
Cape Kennedy and Ascension
Antigua and Ascension
Ascension and Mahe

Lower power HF/SSB radio is used for point-to-point service between:

Antigua and Canary Islands - 10 Kw transmitter

HF/SSB radio is also used at Cape Kennedy, Grand Bahama, Grand Turk, Eleuthera, Antigua, Ascension, and Mahe for ship-to-shore and ground-to-air communications. The equipment is similar to that used for point-to-point service, with transmitter power limited to 2.5 and 10 kw. Net control stations for operation of instrumentation ships are set up as follows:

Cape Kennedy - for launch area.
Antigua - for the broad ocean area (BOA) covering the north and central areas of the South Atlantic.
Ascension - for the South Atlantic area.
Mahe - for the Indian Ocean area.

The ETR HF radio system is shown on page 100.

Distribution of HF equipment on the range is as follows:

	<u>45 kw</u>	<u>10 kw</u>	<u>2.5 kw</u>	<u>500 kw</u>	<u>350 w</u>
Cape Kennedy	5	10	5	4	-
Grand Bahama	-	-	-	6	2
Grand Turk	-	-	-	-	2
Antigua	7	4	3	-	-
Ascension	13	7	4	-	-
Mahe	2	6	-	-	-
Eleuthera	-	-	-	1	2

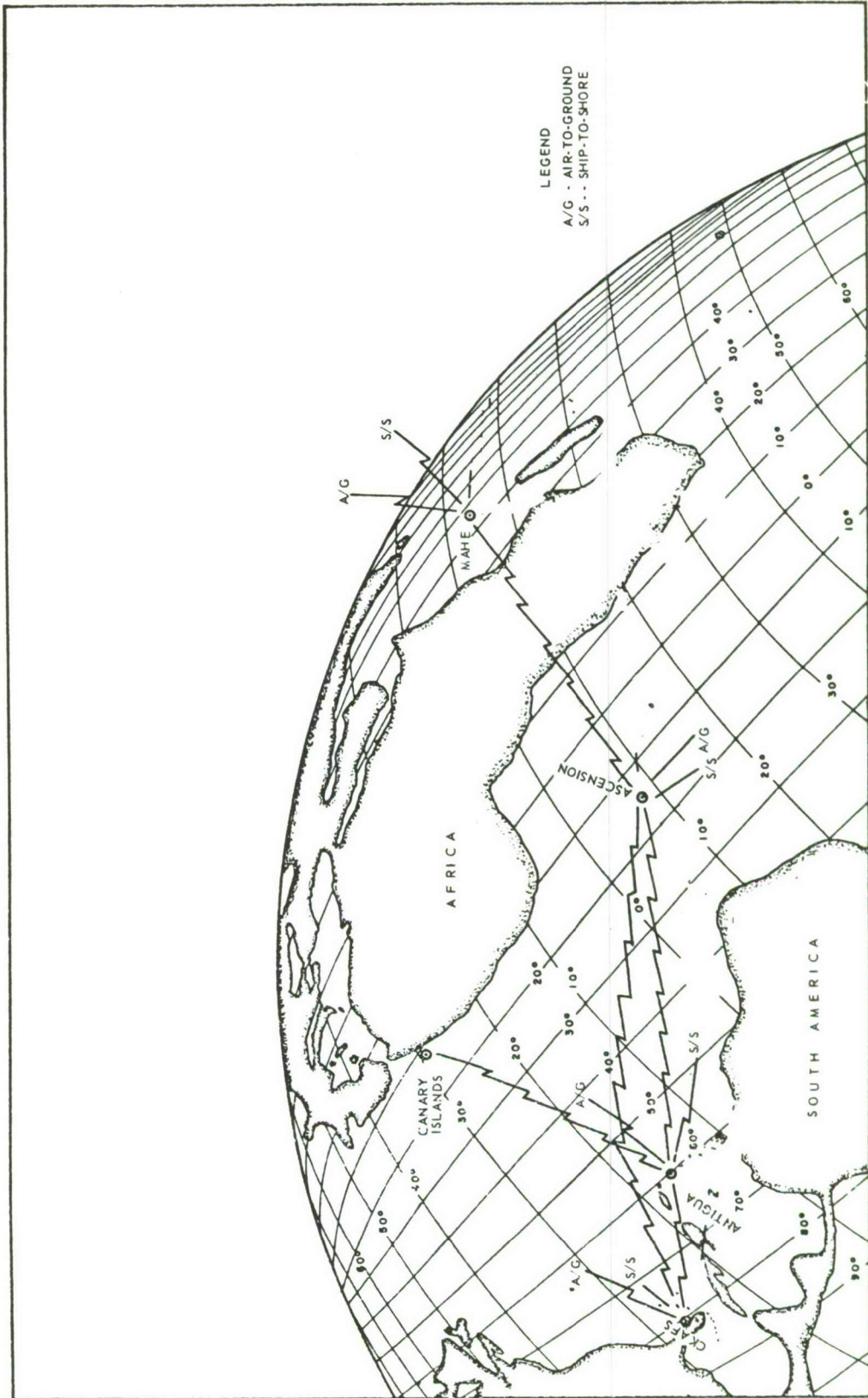

FIGURE 24 AFETR HF RADIO SYSTEM

COMMUNICATIONS

Antenna farms for HF radio at all stations include rhombic, log periodic (fixed and rotatable), discone, monopole, and dipole antennas to meet day and night transmission needs. Cape Kennedy, Antigua, and Ascension have transmitting antenna switching matrices for rapid selection or for changing antennas.

Automatic pathsounder equipment determines the best frequencies to use at a given time over a desired path. A sounder transmitter is used at Ascension with receivers at Cape Kennedy, Antigua and Mahe.

Improved reliability and accuracy of teletype transmission is provided by the use of error detection and correction equipment. This equipment is used between Cape Kennedy, Ascension, and Mahe.

TELETYPE

The teletype network interconnecting ETR stations for handling record traffic is shown on page 102. Teletype circuits are provided on nominal (3 kHz) voice channels of the underwater cable and HF radio by use of AN/FGC-60 telegraph MUX equipment. In 1968, the AN/FGC equipment on the undersea cable was augmented with wireline modems with Rixon converters to increase capacity and reliability. The small numbers on page 102 indicate the number of teletype channels between major stations. End equipment is Teletype Corporation operating at 100 words per minute (wpm). Teletype Corporation equipment, Model 28 series, has been adopted as standard for the Range.

Dedicated, conference, and shared-use circuits are used depending on type of service needed and quantity of traffic. Relay of traffic at major stations is by torn-tape procedures.

Message centers are established at each station for handling administrative traffic. The center at CKAFS has connection with government, military, and commercial teletype systems.

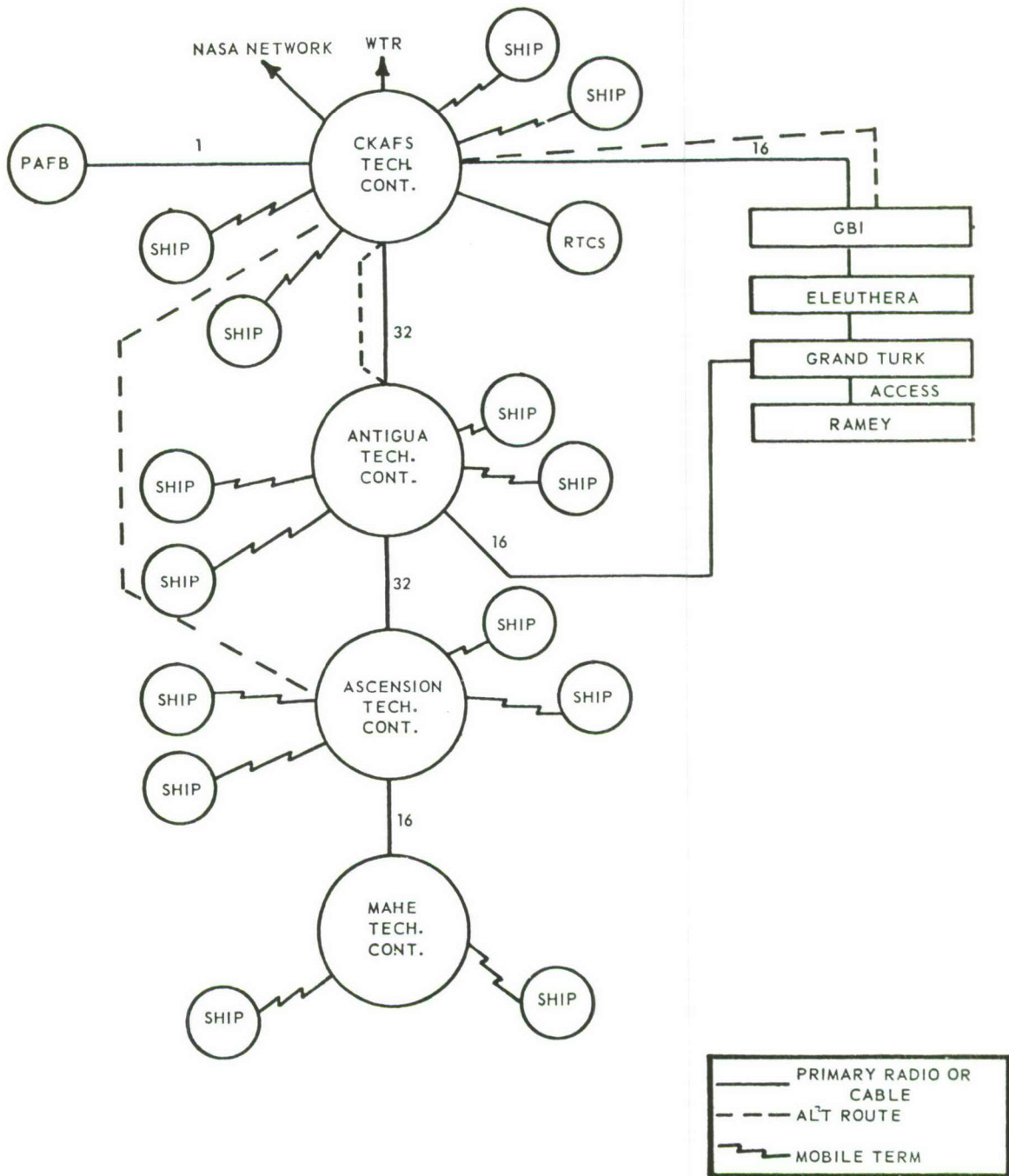

FIGURE 25 ETR TELETYPE DATA NETWORK

COMMUNICATIONS

COMMUNICATION SECURITY (COM SEC) EQUIPMENT

This equipment is available for handling classified traffic in teletype format between major ETR stations and ships.

VHF AND UHF RADIO

Line-of-sight communications to aircraft are available at the major communications stations by VHF and UHF. Transmitters and receivers are located as follows:

	<u>VHF</u>	<u>UHF</u>
Cape Kennedy	10	16
Grand Bahama (and Cays)	9	7
Eleuthera	8	8
Grand Turk	7	9
Antigua	0	4
Ascension	5	4
Mahe	3	2

High power UHF terminals are available at Grand Bahama, Antigua, and Ascension for communications with space capsules in flight (CACOM). These units can track the capsule and can be modulated from Cape Kennedy.

MICROWAVE

Two microwave links are used on the mainland ETR: one for circuits between Cape Kennedy and transmitters at Malabar, Florida; and one for secure voice transmission from Malabar to Patrick AFB.

The link serving radio transmitters extends from Cape Kennedy to Malabar with a relay station at Patrick AFB. One hundred and eight full duplex voice channels are provided from Cape Kennedy to Malabar plus 24 from Cape Kennedy to Patrick.

One ATRAX installation supports the Antigua transmitter site. Twelve voice channels are in service between the communications building on the main base and the transmitter site across the island. A 24-channel ATRAX system is in use on Mahe. This system has terminals at the transmitter, receiver, and tech sites.

COMMUNICATIONS

INTRASTATION COMMUNICATIONS

All ETR stations have outside plant cable distribution systems. Most of this cable is installed underground; however, where the terrain is rocky, as at Ascension, the cable is suspended from poles. The service is extended by installing lateral cables from the feeder cables. Non-loaded and loaded 19-gauge and 22-gauge cable is used.

Transmitting signal levels are generally held at 0 dbm. In addition to these cables, a number of special wideband 16-gauge pairs are included for data transmission and instrumentation. These special pairs are individually shielded and can be equalized to a 4.5 MHz bandwidth. Less than 25 percent of the cable's use at Cape Kennedy is administrative; instrumentation video and test or command control comprise the bulk of the traffic.

Automatic dial telephone systems are installed at all stations. Manual patching is available for connection to undersea cable. By this means, calls can be made from any telephone at one station to any other telephone at another station, if both stations are on the undersea cable. Downrange direct dial service is provided between Patrick AFB and GBI, Eleuthera, GTK, and Antigua via subcable. Ringdown service to PAFB operators is provided to these four stations for uprange traffic. The Patrick operator can also provide manual intrastation service. Relay equipment ranging in capacity from 200 to 600 lines is used at all downrange stations, and X-Y equipment provides 7,000 lines at Cape Kennedy. In addition to the automatic dial telephone system, a multiple 200-line manual switchboard at Cape Kennedy provides service for the security police.

Four interphone systems of major importance extend throughout Cape Kennedy and to several of the island stations. These are the green phone system (point-to-point), the Missile Operation Intercom Systems (MOIS), the Missile Technical Operations Communications (Mitoc) System (network), and Transistorized Operations Phone System (TOPS) which is planned for replacement of old systems. Tops is capable of working into all other audio systems.

(1) Green Phones

The greenphone system is composed of 10- or 12-line manual key panels with a limited number of subscribers. It provides rapid

COMMUNICATIONS

communication for instrumentation supervisors to their operating personnel and to other supervisors. Each supervisor has one or more 10/12-line key panels at his operating position. A call is made by placing one or more key switches in the top position. Subscribers call simply by lifting the handset. Key cabinets have visual and audible signalling. The system is battery operated and is not affected by commercial power failures.

(2) MOIS

MOIS is an intercom system which permits selection of a net rather than an individual station. All related operating positions, such as those for telemetry, are on the same net. Rotary selector switches on the end instruments are used to select the desired net. MOIS maintains usable transmission level with headset operations at the operating positions under severe loading. Access to any net may be limited to certain operators. When an operator selects a net and talks, all other operators who have previously selected the same net will hear him. Conversely, he will hear all other operators talking on the same net.

(3) Mitoc

This transistorized system was designed to replace MOIS in those situations where space was limited yet a 2-wire system was adequate.

(4) TOPS

TOPS is a completely transistorized system which operates either 2 or 4 wire. A variety of end instruments are available; from 2 to 20 channels, indoor or outdoor and for hazardous areas.

AUDIO COUNTDOWN AND AURAL WARNING SYSTEMS

Public address systems are located in each of the technical and operations areas of Cape Kennedy and downrange stations. These systems are used for local area paging of personnel, for dissemination of test and countdown information, and for warning in case of emergencies. Each installation at Cape Kennedy has inputs for local access and over-ride inputs from the countdown and aural warning networks. The countdown net is controlled by the Superintendent of Range Operations (SRO); the SRO can select areas of interest and override any local users to make test announcements. The aural warning system is a switching, tone generating, and distribution system for area coverage to warn personnel of danger or emergency action. Discrete tones are used to alert personnel of particular situations. Voice announcements can also be made.

Administrative intercommunication service is provided by type 1A telephone key systems at Cape Kennedy.

AUDIO RECORDERS

Audio recorders are used at Cape Kennedy and downrange stations to record selected voice channels during operations. At present, the Cape can record 160 voice channels simultaneously at 15/16 ips. These units will be used in a fail-safe operation with automatic changeover to the back-up unit upon failure or reaching the end of tape. By this method, reliable recordings can be made of 100 channels for a period up to 24 hours. Thirty, 4-track - 2 channel playback and tape reproduction units provide 60 channels with voice operated control. These units permit reproduction of recorded information, eliminating all dead space from the data. The system also has two variable speed reproducers and an automatic time announcer.

CLOSED CIRCUIT TELEVISION (CCTV)

Closed circuit television on the ETR is generally limited to Patrick AFB and Cape Kennedy except for boresight TV cameras on precision radars downrange. Systems are used for management and test operations support.

COMMUNICATIONS

TV systems used for test operations support include cameras for launch pad area coverage, spin test facilities, display information distribution, and similar purposes. Three mobile vans are equipped with TV cameras and microwave, as well as wire distribution equipment, for range safety coverage of live launches. Black-and-white coverage only is available. Equipment is standard commercial quality.

A television operations center(TVOC) is centrally located at Cape Kennedy. This center has tape recording, video distribution, switching, monitoring, and quality control capability.

Video signals from fixed installations are distributed by 16-gauge, individually shielded wire pairs especially designed for the purpose. Wideband transmitters, receivers, and repeaters are used for amplification and equalization of circuits.

Repeaters are spaced approximately 3 miles apart for quality transmission of signals with a bandwidth up to 4.5 MHz. These circuits are also used for handling other video signals, such as telemetry data.

CONSOLES

Special communications consoles have been designed and provided to meet special needs. Installations in use include the Range Control Center (RCC), Jet Propulsion Laboratory (JPL), control room in Hangar AE, the DOD Director of Recovery Forces for Apollo, Range Safety, and Pad Safety.

RANGE COMMUNICATIONS CONTROL CENTERS

Operations control of ETR communications is exercised by channel switching and technical control centers at major stations. These centers allocate, monitor, and maintain transmission quality on all off-base circuits and technical operations nets for their station. Equipment and capabilities are limited to manual and semiautomatic operation.

Cape Kennedy is the focal point for all range circuits, mission control centers, range user nets, and other government agencies. Antigua, the nodal point for the Caribbean area, is a relay station for traffic from Ascension and is the net control station for ship and aircraft operations in the broad Atlantic area. Ascension is the nodal point for all stations and ships in the South Atlantic, Africa, and the Indian Ocean area. Each of these stations has complete manual and semi-automatic Range Communications Control Center capabilities.

DATA TRANSMISSION

The ETR Communications Data Transmission System previously consisted of a combination of voice frequency (VF) carrier telegraph terminals and Rixon parallel-to-serial (P/S) and serial-to-parallel (S/P) digital multiplexers. These provided a maximum capacity of 1200 bps per 3-kHz VH channel.

Because of growing range users data transmission requirements in real or near-real time, a major expansion has been undertaken in the area of data transmission.

The following high frequency (HF) radio and wireline (WL) data modems with capabilities of 2400 bps per 3-kHz channel are available:

	<u>HF</u>	<u>WL</u>
Cape Kennedy	7	13
Tel-4 Telemetry	-	7
Grand Bahama	-	3
Grand Turk	-	3
Antigua	6	5
Ascension	6	3
Mahe	2	
Ships	1	-

These modems have been designed to meet various military standards operating under a common user concept, with user's interfaces in accordance with MIL-STD-188B. To satisfy range user's requirements of higher speeds, wideband data modems are being implemented which will utilize existing or presently under installation, 48 and 240-kHz wideband channels. These will provide selectable data transmission rates up to 72kbps in the 48 kHz and 360 kbps in the 240 kHz wideband channels. These modems are now operational and allocated as follows:

	<u>48 kHz</u>	<u>240 kHz</u>
Cape Kennedy	4	6
Tel-4 Telemetry	6	6
Grand Bahama	2	-
Grand Turk	2	-
Antigua	2	-

For more detailed information and up-to-date quantities and distribution of equipment, refer to the Range Communications Handbook.

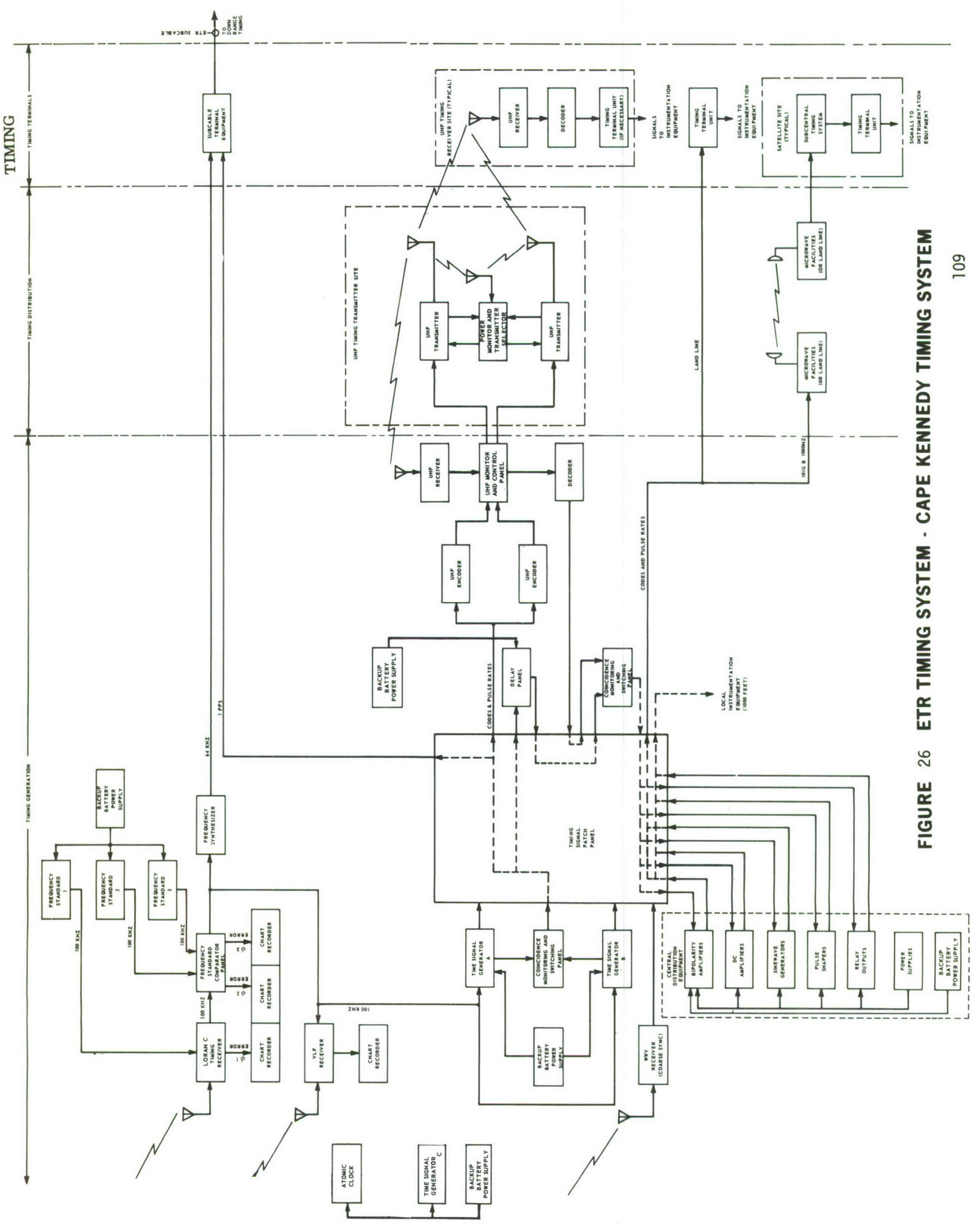
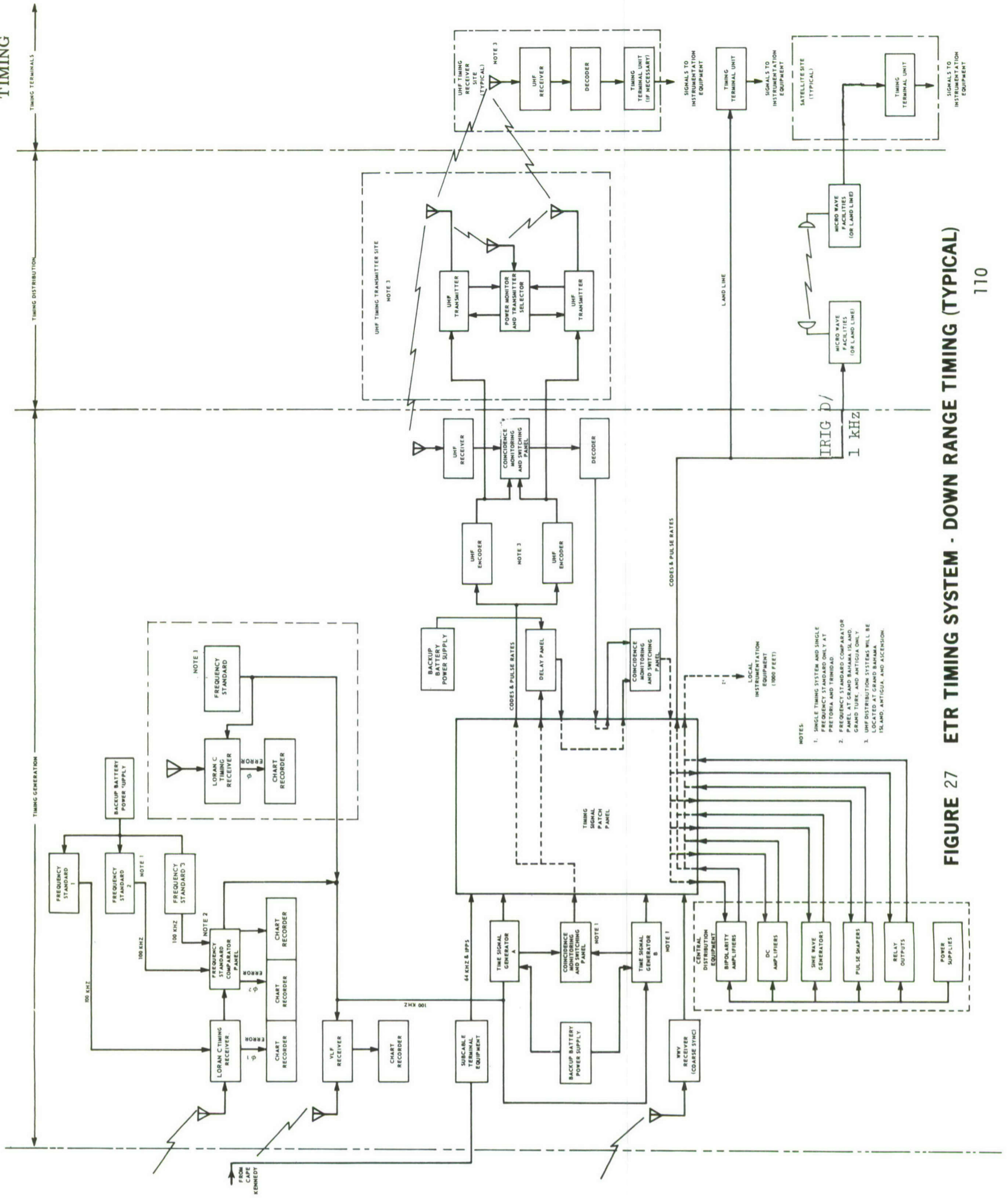

FIGURE 26 ETR TIMING SYSTEM - CAPE KENNEDY TIMING SYSTEM



- NOTES
1. SINGLE TIMING SYSTEM AND SINGLE FREQUENCY STANDARD ONLY AT PRETORIA AND ANTIGUA ONLY.
 2. FREQUENCY STANDARD COMPARATOR PANEL AT GRAND BAHAMA ISLAND, GRAND TURK, AND ANTIGUA ONLY.
 3. UHF DISTRIBUTION SYSTEMS WILL BE LOCATED AT GRAND BAHAMA ISLAND, ANTIGUA, AND ASCENSION.

FIGURE 27 ETR TIMING SYSTEM - DOWN RANGE TIMING (TYPICAL)

TIMING

The time signal generators produce 24 different time codes (presence-absence, pulse width, and pulse position), with frame rates ranging from 1 fph to 10 fps and element rates ranging from 1 ppm to 1000 pps. Time words are coded in straight binary seconds time-of-day, modified binary hours-minutes-seconds and 10th seconds time-of-day, binary coded decimal days-hours-minutes-seconds and 10th seconds time-of-year, and combinations thereof. In addition, 28 pulse repetition rates are produced, ranging from 1 pph to 100,000 pps. The time signal generators are synchronized to world standard Universal Time Corrected (UTC) with the aid of the East Coast Loran C Chain which is controlled by the U.S. Naval Observatory and radio station WWV which is controlled by the National Bureau of Standards.

All outputs of the time signal generators are fed to a patch panel where plug-in modular distribution amplifiers have input and output signal terminations. Through system patching, such output configurations as the following are possible:

- (1) High Level Signals. Forty-two channels of high-level timing signals are available to range user equipment near the Range Control Center, the generating point (see Timing Terminal Signals, Pan Am Spec. A600106). Thirty-six channels of dry contact relay closures are also available locally.
- (2) Low Level Signals. Sixty-four channels of low-level signals, distributed over the Cape by the communications system, are sent out as low-level spikes to be shaped and amplified by timing terminal units. Fourteen channels of amplitude-modulated sine wave signals suitable for communication line transmission are also available.

CENTRAL TIMING SYSTEM (DOWNRANGE)

The frequency sources at GBI, Grand Turk, and Antigua Central Timing are identical to those at CKAFS. Eleuthera and Ascension use free running ultra-stable oscillators, manually corrected to maintain specified synchronization to an atomic frequency standard (see page 112).

All downrange stations contain dual time signal generators and a signal comparator.

Loran C and WWV provide synchronization for all downrange stations. Backup synchronization is provided from CKAFS Central to GBI, Eleuthera, Grand Turk, and Antigua via the ETR submarine cable.

TIMING

Signal A1: 1000 pps Width Code, IRIG Format A

General:

The Standard IRIG Format A, 1000 pps Width Code, is composed of the following:

- 1) 10 pps frame reference markers R-(P₀ and P_R)
- 2) Binary coded decimal time-of-year code word (34 binary digits)
- 3) Control functions (27 digits)
- 4) Straight binary time-of-day code word (17 binary digits)
- 5) 100 pps position identifiers (P₀ through P₉)
- 6) 1000 pps index markers.

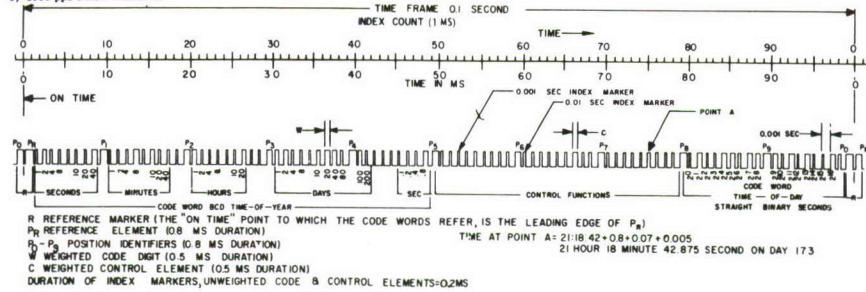

Signal B1: 100 pps Width Code, IRIG Format B

General:

The Standard IRIG Format B, 100 pps width code, is composed of the following:

- 1) 1 pps frame reference markers R-(P and P_R)
- 2) Binary coded decimal time-of-year code word (30 binary digits)
- 3) Control functions (27 binary digits)
- 4) Straight binary time-of-day code word (17 binary digits)
- 5) 10 pps position identifiers (P₀ through P₉)
- 6) 100 pps index markers

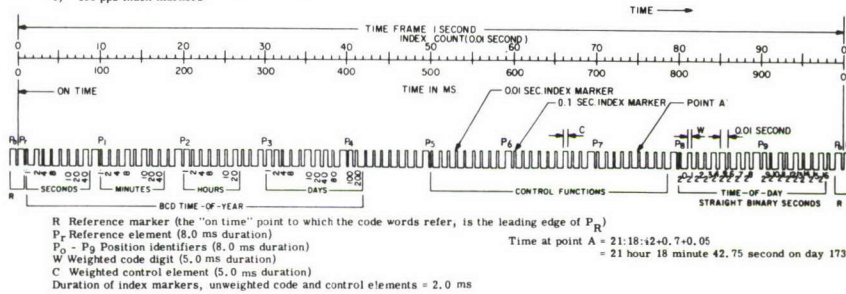

Signal C1: 2 pps Width Code, IRIG Format C

General:

The Standard IRIG Format C, 2 pps Width Code, is composed of the following:

- 1) 1 ppm frame reference markers R-(P₀ and P_R)
- 2) Binary coded decimal time-of-year code word (23 binary digits)
- 3) Control functions (63 binary digits)
- 4) 12 ppm position identifiers
- 5) 2 pps index markers.

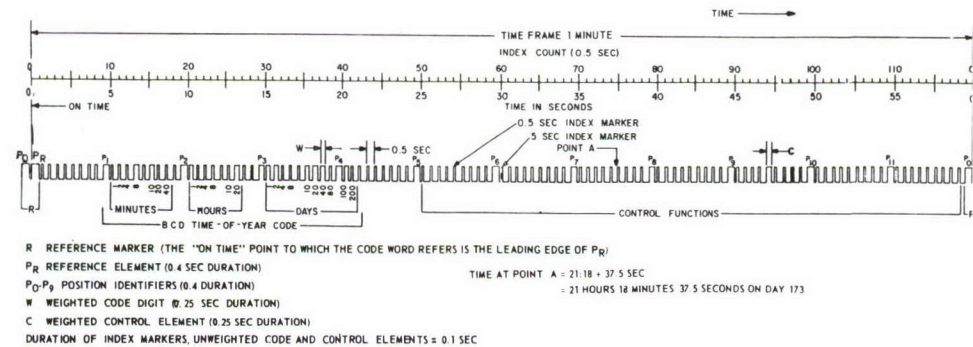

FIGURE 28 TIMING CODES, IRIG FORMATS A, B, AND C

Signal **D1** : 1 ppm Width Code, IRIG Format D

General:

The standard IRIG Format D, 1 ppm Width Code, is composed of the following:

- 1) 1 pph frame reference markers R-(P₀ and P₉)
- 2) Binary coded decimal time-of-year code word (16 binary digits)
- 3) Control functions (9 binary digits)
- 4) 6 pph position identifiers
- 5) 1 ppm index markers.

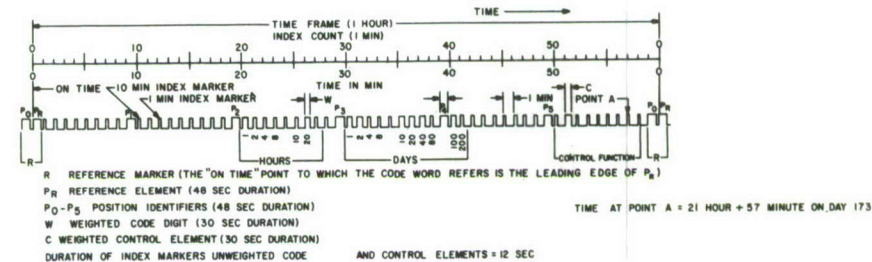

Signal **E1** : 10 pps Width Code, IRIG Format E

General:

The Standard IRIG Format E, 10 pps Width Code, is composed of the following:

- 1) 6 pps frame reference markers R-(P₀ and P₉)
- 2) Binary coded decimal time-of-year code word (28 binary digits)
- 3) Control functions (45 or 27 binary digits)
- 4) 1 pps position identifiers (P₀ through P₉)
- 5) 10 pps index markers

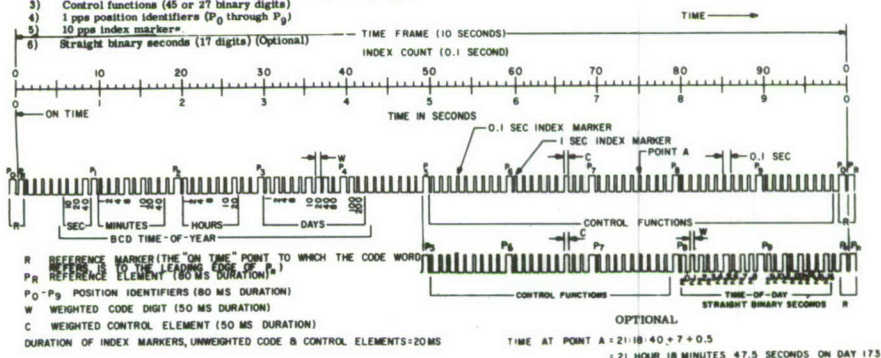

SIGNAL CHARACTERISTICS

CHARACTERISTIC	SIGNAL				
	A1	B1	C1	D1	E1
NO. OF DIGITS	34	30	23	16	26
PULSE RATE	110 pps	100 pps	2 pps	1 ppm	10 pps
FRAME RATE	10 fps	1 fps	1 fpm	1 fph	6 fpm
CODE SUBWORDS	Days, Hours, Minutes, Seconds, 0.1 Seconds	Days, Hours, Minutes, Seconds	Days, Hours, Minutes	Days, Hours	Days, Hours Minutes Seconds
POSITION IDENTIFIERS	100 pps	10 pps	12 ppm	6 pph	1 pps

1. Code words are referenced to the leading edge of the second pulse of the preceding frame reference marker.
2. Code word reading frequency is equal to frame rate.

FIGURE 29 TIMING CODES, IRIG FORMATS D AND E

TERMINAL TIMING SYSTEMS

A timing terminal unit is a power supply and chassis that can accept sub-chassis modules. Five types of plug-in modules are available: (1) code shapers (to develop high-level coded time signals), (2) pulse shapers to produce high level timed pulses synchronized with range time), (3) neon drivers (for high-level signals for neon lamps), (4) sine wave drivers to produce amplitude-modulated sine waves whose frequency is derived from the repetition rate and the amplitude from the coded time), and (5) tone detectors (which produce high-level time-coded signals or relay closures from an amplitude-modulated sine wave). The outputs of the timing terminal units are high-level signals used for data clocking, neon light timing for metric camera operation, and timing records on magnetic tape and oscillograph charts.

The accuracy of the timing signals from the terminal unit is deteriorated by transmission delays, the inherent delay of the timing terminal unit, and the response time of the customer instruments. When correlation accuracy better than 1 msec is needed, these delays can be measured and incorporated in the data reduction process.

SUBCENTRAL TIMING SYSTEMS

Subcentral Timing Systems at satellite instrumentation sites on the Florida mainland (accept and detect a signal from the central timing system, (2) generate pulse rates, coded timing signals, and position identifiers, and (3) provide standard signals to instrumentation equipment and timing terminal units.

The transmission delays are periodically measured and compensated for so that the subcentral sites are within 5 μ sec of synchronization with the central timing system.

SHIP AND AIRCRAFT TIMING SYSTEMS

Timing to ships and aircraft is supplied by specially constructed units. Synchronization is maintained by time comparisons with WWV and a frequency standard. (See Ships and Aircraft Section for typical timing system.)

UHF TIMING DISTRIBUTION SYSTEM

A Time Division Multiplexed Timing Distribution System (TDMTDS) is in operation at Cape Kennedy, Grand Bahama Island, Antigua, and Ascension.

At Central Timing, an encoder time multiplexes early signals from the generators and modulates a UHF transmitter. Propagation delay is compensated for in the receiving system.

For reliability, redundant encoders and transmitters, with a power monitor, provide automatic switch-over if a transmitter fails. The outputs of the transmitters feed omnidirectional antennas.

A directional antenna, timing receiver, and decoder at the receiving sites provide outputs suitable for driving standard timing terminal units. Selectable decoder delay, from 200 microseconds to 1 microsecond, accommodates propagation delay within a 35 mile radius.

TECHNICAL CHARACTERISTICS (TIMING TERMINAL SYSTEM)

OUTPUT SIGNAL FORMATS

See PanAm Specification A-600106, Timing Terminal Signals.

OUTPUT SIGNAL CHARACTERISTICS

Code Shaper Module

Output: 0 to +60v across 300 ohm resistance and 0.10 μ f capacitor to a maximum of 200 ma through loads less than 300 ohms. Rectangular pulse with a rise time less than 2 μ sec and decay time less than 10 μ sec.

Delay: 5 ± 2 usec

Pulse Shaper Module

Output: Same as code shaper module

Delay: 5 ± 2 usec

Neon Drive Module:

Output: +1 to +15 ma through NE-51 lamp (on an adjustable bias of 50 to 500 ua) shunted by 0.1 μ f capacitor.

Delay + Rise Time: $50 \pm 0/-40$ usec

Sine-Wave Driver

Output: 30v peak-to-peak across 100-ohm resistive load shunted by a 0.015 μ f capacitor with less than 5% harmonic distortion.

TIMING

Phase Jitter: $0 \pm 10 \mu\text{sec}$

Tone Detector

Output: 0 to +60v across a 300-ohm resistance paralleled by a 0.1 μf capacitor or 200 ma for loads less than 300 ohms, and a relay contact closure.

Delay: 5 msec maximum at 1 kHz, contact closure delay of 5 msec and release delay +20 mec.

ACCURACY

Cape Kennedy and downrange central timing systems generate a basic frequency with an accuracy better than five parts in ten billion (5 parts in 10^{10}). The basic frequency is then subdivided into slower repetition rates and time-of-day and time-of-year codes are accumulated. The generators used at these stations have "clocked outputs" that cause the leading edges of all code and repetition rate pulses to be coincident to within 1 μsec .

The leading edge of timing pulses generated at the following stations is coincident to transmitted UTC within the following figures:

<u>Station</u>	<u>μsec</u>
Cape Kennedy AFS	2
Grand Bahama Island	10
Eleuthera	1,000
Grand Turk	10
Antigua	10
Ascension	150
Ships	5,000
Aircraft	10,000

The figure shown represent the time correlation of the timing pulse generated at the central timing generator. The correlation of the timing pulse furnished to the end or using instrumentation will have a somewhat lower degree of accuracy, depending on the method of distribution and the signal furnished.

If the station has TDMTDS, the correlation accuracy provided to the end instrumentation will be within 5 μsec of the timing generator. If a relay closure is needed at the end instrumentation, accuracy will decrease the timing signal by introducing jitter and propagation delay.

TIMING

KSC TIMING SYSTEM

The KSC timing systems are designed to perform the following specific tasks:

- a. Provide an extremely accurate and stable source of timing signals at rates and in formats consistent with the needs of area instrumentation, monitor, control, display, and analysis.
- b. Maintain time synchronization with universal primary standards and the Air Force Eastern Test Range (AFETR).
- c. Provide precision discrete frequency signals referenced to universal primary standards.
- d. Distribute timing and frequency signals to all NASA and AFETR activities at Merritt Island and at other KSC locations.
- e. Generate, distribute, and display countdown timing signals from launch or checkout computer-controlled tests.

To provide the accuracy needed at KSC, locally generated signals are continuously compared with standard radion transmissions and synchronized with AFETR timing. Inputs are compared and then generated as a signal coded for distribution consistent with the user's instrumentation requirements. Accuracy is further increased by distributing the signals on high-quality transmission cables, whereby propagation uncertainties due to atmospheric conditions remain nominal and greater mechanical integrity is provided to the system.

Correlated timing signals are distributed to all instrumentation facilities and launch activities.

The Central Timing Station maintains two identical sets of equipment for accumulating and generating accurate time and frequency signals. Each set consists of a standard reference oscillator, a time-base generator, and a timing signal transmitter. The duplication of equipment serves two purposes: it provides a standby, and ensures high accuracy by comparing the outputs of two sets of equipment. Because of the large size of Merritt Island, subcentral satellite stations provide remote areas with signals of central timing accuracy.

The present KSC timing concept:

- a. Provides a timing synchronization capacity for local and interrange accuracies of ± 10 microseconds predicted for the global and deep-space requirements on the UT2 time scale (reference Interrange Instrumentation Group (IRIG) Document 106-62).

- b. Serves approximately 150 measurement, instrumentation, checkout, monitor, control, and display activities with coded time-of-day, count-down clock, sequence control, and asynchronous event signals.
- c. Correlates times and frequencies of all NASA launch and flight activities at KSC with stability of ± 1 part in 10^{10} .

The Central Timing Station time base generator provides the basic coded time-of-day, as well as all pulse and timing outputs required for timing operation. The rate dividers in the time base generator may be advanced or retarded to allow for synchronization with the external synchronization sources. The basic accumulation of time is binary coded decimal (BCD). Translational techniques convert BCD to straight binary hours, minutes, and seconds. Each code is then scanned to provide inputs for signal transmission.

Station WWV. Synchronization with WWV is accomplished by receiving a standard WWV time broadcast. Assuming the propagation delay is known, the timing systems can be synchronized within 100 microseconds.

Very Low Frequency (VLF). To obtain and maintain accuracies of from one part in 10^9 to a few parts in 10^{10} , very low frequency (VLF) standard broadcasts have been initiated. In the VLF range, extremely low attenuation and excellent phase shift stability permits comparison to a few parts in 10^{10} by observing the phase relationship between the carrier and local frequency standards.

Loran C Radio. Loran C radio transmissions for time synchronization offer microsecond accuracies which are several orders of magnitude better than those of station WWV or VLF. A Loran C receiver is provided at the Central Timing Station to allow relative phase measurements between the Loran C carrier and the locally generated reference.

AFETR. Timing is also synchronized with AFETR timing by comparison with the received AFETR master time signal.

TIME CALIBRATION

Available for time-of-day synchronization are the WWV high frequency transmissions and the VLF broadcasts. These standard transmissions allow synchronization to approximately 1 millisecond after extended observation periods. The VLF transmission for time setting provides greater synchronization accuracy.

TIMING TERMINAL UNIT

The point of electrical connection where timing signals are made available is the Timing Terminal Unit. The Timing Terminal Unit accepts low level pulse and sine wave signals from land lines, reshapes these signals to dc conditions, modulates signals or generates higher levels as required, and delivers them at specific voltage and impedance levels to local data collection equipment.

Terminal units in single or multiple quantities are located at every instrumentation site which requires central timing. The exact functional operations contained in a timing terminal unit may be varied to suit the requirements of the timing site by insertion of appropriate plug-in circuit modules. These modules are essentially interchangeable and may be used in any desired arrangement within the particular terminal unit. The Timing Terminal Unit frame contains the power supply for all plug-in modules, all necessary interconnecting wiring between modules, and all wiring for input signals and output signals to and from the modules.

Outputs for recording pen and oscillograph galvanometer acutation, camera neon driving, magnetic tape recording, signal loss alarm, etc., are available. Virtually any signal may be accommodated by the terminal unit for any format.

Five code formats (IRIG formats A, B, C, D, and E) form the basis of timing signal distribution at KSC. Provisions for two additional codes have been made.

ULTRA HIGH FREQUENCY (UHF)

The UHF multiplexed timing transmission, slaved to the AFETR central timing generator, is radiated from a location near the Cape Kennedy Central Control. The UHF transmission is the sole source of timing signals for tracking sites located off the Kennedy Space Center.

Reception at remote receiver activities is through directional UHF receiving antennas. Coaxial transmission lines connect the receiving antenna to a UHF receiver for the transfer of RF signals. Reception is limited to line-of-sight transmission (approximately 65 kilometers).

The UHF timing distribution system performs the following functions:

- a. Accepts up to 80 time code and repetition rates from an existing time code generator and multiplexes these codes and repetition rates for transmission on a single channel.
- b. Transmits this multiplexed information over a UHF link to receiver sites whose antennas are within the line of sight of the UHF transmitter (up to 65 kilometers).
- c. Receives and amplifies the transmitted information to a level suitable for a decoder operation.
- d. Decodes the various repetition rates and time codes into separate channels with signal characteristics capable of operating Timing Terminal Units.

COUNTDOWN TIMING SYSTEM

The KSC countdown timing system is designed and equipped to:

- a. Generate countdown timing signals under automated and/or human control at 27 KSC locations and KSC complexes at Cape Kennedy.
- b. Encode these signals in serial form for transmission over voice-quality telephone lines.
- c. Distribute the signals through central switching stations to all activities concerned.
- d. Decode and translate the signals into parallel lines for energizing countdown readout displays at all KSC locations and KSC complexes at Cape Kennedy.

SYSTEM DESCRIPTION

In the systems concept, two sources of countdown timing are considered: those originating at the launch complex and those originating at local test and checkout positions. Both consist of a countdown generator/decoder combination. The entry of count data at the launch complex is automated (parallel binary coded decimal input is accepted). The test and checkout positions include a remote control panel for the entry of count data by a test conductor. Each system is of modular construction. The systems can count down from a present time, and count up from the point of liftoff. The count is in seconds, minutes, hours, and days with a sign digit to indicate whether the displayed time is a countdown or a countup.

System parameters are:

- a. The transmission medium is 19-gauge wire in pairs, nominally 600-ohm impedance, unshielded common telephone wire.
- b. The total length of the wire within the network may approach 500,000 feet.
- c. The signal would be transmitted at a nominal zero (0) dbm level.

Modulation ratios of 3 to 1 (burst-to-residual) appear optimum. To allow for anticipated crosstalk and noise signals along the transmission path by neighboring signals within the bundle of pairs, and from electric and magnetic fields external to the cable, the modulation ratio set at the encoder is made continuously adjustable to a 4 to 1 maximum ratio.

GENERATOR/ENCODER

The generator portion of the generator/encoder is made up of the digital time accumulator.

The encoder portion of the generator/encoder consists of the digital circuitry for developing the serialized pulse output. The encoder output is retransmittable over voice-quality telephone lines. The serial line outputs are binary encoded countdown time values with appropriate frame synchronization pulses (included to contain all required information for the transmission of the sign plus eight digit data). Impedance and signal output levels are consistent with local telephone and AT&T long lines. Both tone burst and level shifts outputs are available.

RECEIVER/DECODER

The receiver portion of the receiver/decoder demodulates the tone burst input signal or conditions the dc shift input signal in preparation for decoding.

The decoder portion of the receiver/decoder detects the serial input bit rate, stores time data in a shift register, translates this data into the seven-level display format, and provides driving power for ten readout displays.

FORMAT

To provide for a distribution format that will permit translating input data into commonly used computer language (if the countdown should be required for other than display reasons), a straight binary coded decimal format was selected.

RANGE COUNT CONTROL

DESCRIPTION

Range Count Control at Cape Kennedy provides:

Off-on sequential control of vehicle and instrument functions on a Universal Time base

Holdfire controls for use by range safety, range user instrumentation control

Direct reading display of countdown time

Dissemination of liftoff time

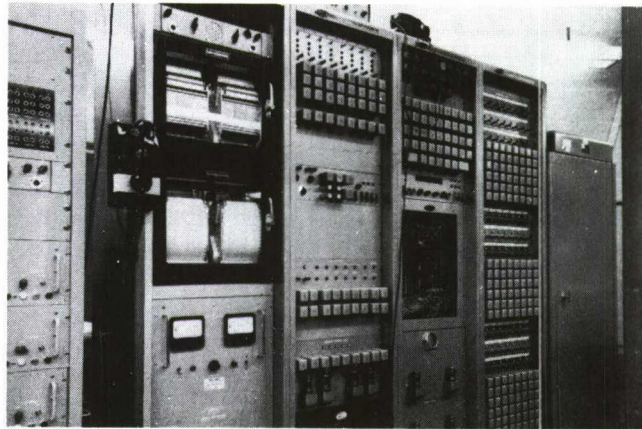

COUNTDOWN SEQUENCER

The system includes a countdown generator in the Range Control Center (RCC), which may be used before start of vehicle countdown, a sequencer in the blockhouse which automatically controls operations during countdown and firing, a real-time programmer in the RCC for programming events according to Universal Time, countdown indicators throughout Cape Kennedy to show the progress of the count, and a distribution system consisting of three nets for interconnection of these. The switching of blockhouse and Range Control Center equipment into these nets is controlled from a console at the Range Control Center.

Countdown Generator

A countdown generator in the Range Control Center provides countdown information until T-90 min, at which time the sequencer in the blockhouse switches to the distribution net and begins countdown. The countdown generator also gives positive countdown time after liftoff. This generator produces signals as described in the sequencer section.

Sequencer

Three types of sequencers are used: Model II, III, and IV. They are functionally similar, so the following description of the Model IV applies to all.

Central timing supplies 10-pps timing signals to a transistorized decade counter which, in turn, supplies a 1-pps signal to four 12-level, 10-position stepping switches corresponding to units of seconds, tens of seconds, units of minutes,

RANGE COUNT CONTROL

and tens of minutes. The seconds stepping switches provide continuous signals corresponding to tens of seconds and units of seconds for visual display. In addition, the seconds stepping switches generate pulses corresponding to tens of seconds and units of seconds for each second of a minute, i. e., 0 to 59 sec. These signals, along with the tenth-of-second signal from the decade counter, are supplied to a one-tenth per second encoder which produces groups of positive signals corresponding to (0 to 0.1), (0.2 to 0.3), (0.4 to 0.5), (0.6 to 0.7), (0.8 to 0.9) for each second of time. These groups of signals terminate in a patch panel for timed selection of function relays.

The minutes stepping switches supply visual indicator signals and generate ground signals for each tenth of a second. These pulses are supplied on two lines -- one for even tenths of seconds from -10 to +10 min, the other for odd tenths of seconds. These signals also terminate on the patch panel. The sequencer control relays (function generators) may be programmed for start-stop at any one-tenth second during the countdown from -10 to +10 min (or at 1-min intervals from -90 to -10 min). This is done by patching in plus signals corresponding to groups of tenth-of-second signals, simultaneously with the particular ground (corresponding to the related even or odd tenth of second) which corresponds to the minute selected.

Visual countdown indicator signals are generated by countdown step switches. A 21-bit (five 4-bit digits and a sign bit) signal is supplied to an encoder which produces an amplitude-modulated 345-Hz signal for distribution. A decoder and indicator present the countdown information.

Two types of holdfire are possible, automatic and manual. Twenty circuits are provided for automatic holdfire. During the interval that these holdfire circuits are programmed, an external condition is sampled. If a malfunction occurs during this time (shown by absence of +28 vdc on the line), countdown will be automatically interrupted. Two modes of restart, automatic and manual, are provided for each programmed holdfire circuit by means of a selector switch. In the automatic restart position, the countdown automatically restarts when the malfunction producing the holdfire has been cleared. In the manual restart position, the countdown must be restarted manually when the malfunction has been cleared. Automatic holdfire override is also provided for each circuit.

The countdown may be manually interrupted by holdfire switches on Range Safety Officer, Superintendent of Range Operations, Pad Safety Supervisor, and Range User consoles.

Real-Time Programmer

By use of the Range Holdfire Net Distribution System, a precise start pulse is sent from the real-time programmer to the blockhouse sequencer. The sequence countdown will then reach T-0 at the predicted Universal Time for T-0 in order that launch program window requirements may be met.

RANGE COUNT CONTROL

The real-time programmer, installed in the RCC, therefore provides automatic programming tied to Universal Time and 10 time-selected relay closures for control functions. Each function may be programmed in 10 msec intervals from 00:00:00 to 23:59:59 Universal Time.

Visual Countdown Display System

The Visual Countdown Display System consists of an encoder, decoder, a code converter, and an indicator. The information to be transmitted is presented to the encoder as a frame of 21 binary bits, consisting of a sign bit and 4 bits each for 5-decimal digits. A 24-v positive step is provided for each information change, or once each second for synchronization.

The binary information is stored in a shift register and is read out at the carrier frequency (345 Hz) so that each cycle of the carrier represents one binary bit. The carrier is amplitude modulated so that this cycle will be unit level if the bit contains a zero or three units level if the bit contains a one. The two leading bits are ones and are used to synchronize the receiving end equipment. The decoder receives the amplitude-modulated signal, demodulates the carrier, and stores the binary information in a shift register. It then provides continuous parallel read-out of the register to the code converter until the next frame is received. The information is retained in the register until the arrival of the two successive ones transmitted at the start of a new frame. The 21 information bits are then transferred in parallel to a converter which changes the 4-bit code (called BUDX) to a 7-bit code. The 36 bits (five 7-bit digits and a polarity bit) are transmitted to the indicator where they are presented as 5-decimal digits and a sign.

Liftoff Time Dissemination

Liftoff is detected by a switch under the booster which signals the real-time computer and a relay in the sequencer. This relay energizes a 51-contact relay in the Range Control Center. The output of this relay is called "first motion" time and may differ from liftoff time by as much as 100 msec.

TECHNICAL CHARACTERISTICS

<u>Sequencer</u>	<u>Mod II</u>	<u>Mod III</u>	<u>Mod IV</u>
Function control circuits	72	120	60
Function initiation at:			
0.1-sec intervals		-90 to +10 min.	-10 to +10 min.
0.2-sec intervals	-90 to +10 min.		
1-min intervals		-199 to -90 min.	-99 to -10 min.
Automatic holdfire circuits	8	100	20
Manual holdfire circuits	5	5	5
Reset interval	-90:59 to 0 min.	-999 to 0 min.	-99:58 to 0 min.
Recorders	2 (40 pen, 2 speed)	4 (40 pen, 2 speed)	2 (40 pen, 2 speed)
Operating time	-90 to +10 min.	-1,000 to +10 min.	-90 to +10 min.

RANGE COUNT CONTROL

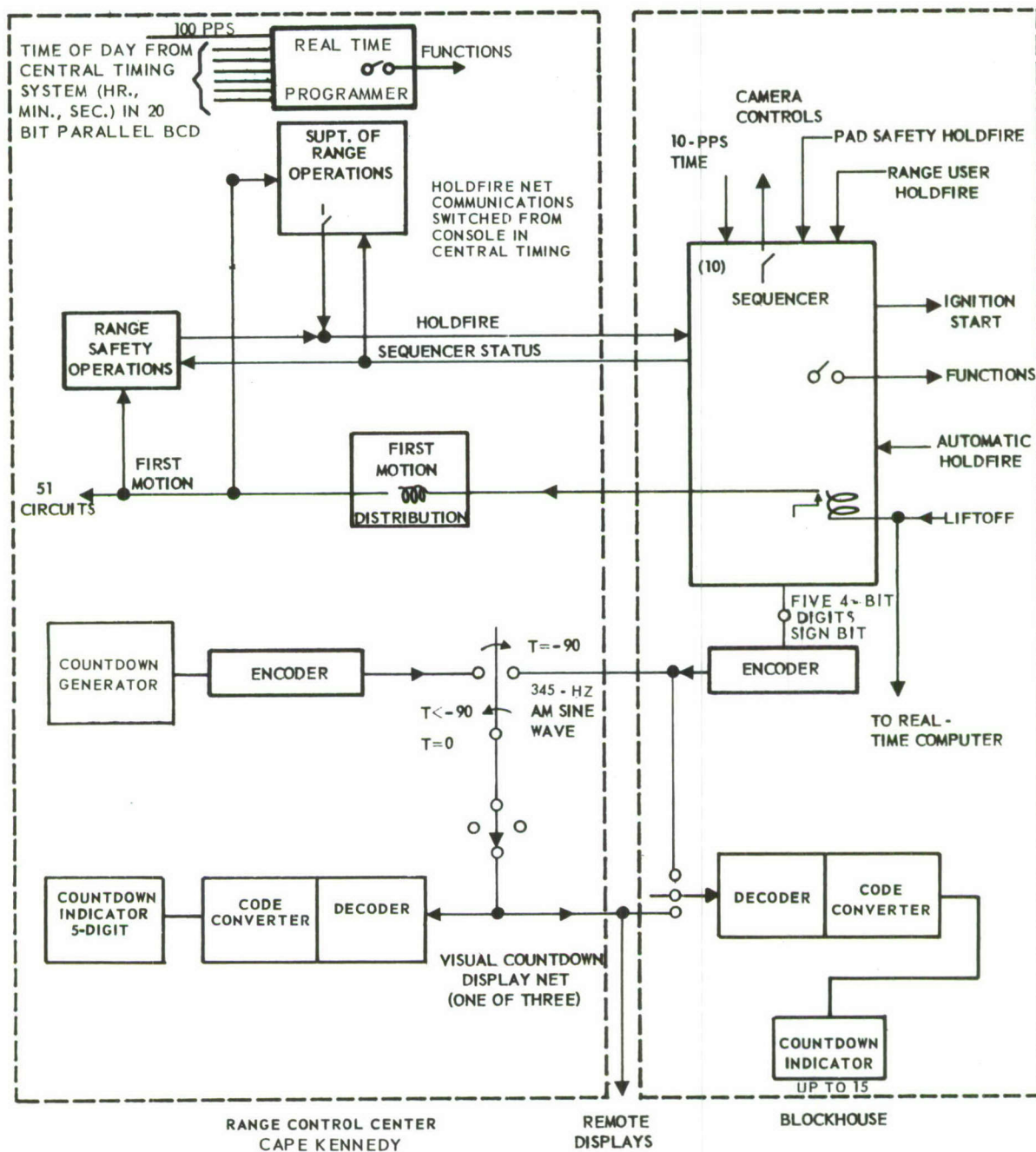

FIGURE 30 ETR FIRING SYSTEM

Real Time Programmer

Input: Second, minute, and hour of day in 20-bit parallel binary coded decimal (BCD) format plus 100 pps repetition rate.

Function control circuits: Ten may be programmed throughout the day in 10 msec increments.

Encoder

Input: Current pulses of 300 ma peak at 28 v for 20 msec at 1 sec intervals

Operation times: 140 msec read in, 120 msec readout

Output: Amplitude-modulated 345-Hz sine wave

Decoder

Input: Variable, depending on line length

Operation times: 70 msec read in, 930 msec readout

FREQUENCY CONTROL AND ANALYSIS RADIO FREQUENCY MANAGEMENT

The Air Force Eastern Test Range is assigned a limited number of frequencies for testing and operational purposes. Due to this factor and because of the great number of communications-electronics equipment radiating within the assigned frequency range, strict adherence to specific frequency management procedures is of the utmost importance. To preclude interference problems from arising because of the assignment of specific frequencies for exclusive and/or shared use, all electromagnetic radiations on the ETR must be approved by the Frequency Branch, Directorate of Range Operations, Patrick Air Force Base, Florida.

FREQUENCY ASSIGNMENT AND CONTROL

All electromagnetic radiating devices operating on the ETR must be controlled to ensure the maximum use of the limited number of assigned frequencies. This is accomplished by frequency assignment and control procedures, which provide for frequency use, sharing, and/or scheduling. In conjunction with frequency management, certain portions of the spectrum are monitored to detect, locate, and, where possible, eliminate or alleviate interference to range users. The following general procedures are employed for accomplishing frequency management:

- (1) Proposed operating agency submits request for assignment of frequency or band.
- (2) ETR Frequency Branch assigns an operating frequency to using agency.
- (3) User requests approval to radiate for a specific time on the assigned frequency, if scheduling is specified in the Radio Frequency Authorization (RFA).
- (4) The frequency spectrum is monitored to ensure interference-free environment, adequacy of signal, and compliance with assignment parameters.
- (5) Suppression or elimination of interference, if any.

Range users requiring use of frequencies should refer to AFETR Regulation 100-3 and 30 Series, Range Communications-Electronics Instructions (RCEI's). The Frequency Branch should be contacted as soon as possible after requirements are known to allow sufficient time for processing frequency applications, as outlined in RCEI 30-78.

FREQUENCY SCHEDULING

Since the same frequencies or bands of frequencies may often be shared by several range users, a frequency authorization does not necessarily authorize transmission without prior scheduling. Unless the RFA specifically states otherwise, permission to radiate is obtained by one of the following means:

(1) If the frequency is specified in paragraph 1.9 of an AFETR Operations Directive (OD) and if radiation will occur during an officially scheduled test operation involving that OD, permission to radiate is inherent in the scheduling of the OD and assignment of a test number on the Range Schedule. Radiation time will be that specified in the countdown document or test schedule.

(2) If radiation is in conjunction with a minor support test, radiation time will be arranged through the Air Force Range Control Section, Directorate of Range Operations.

(3) All radiation not covered by (1) and (2) above will be scheduled through Cape Frequency Scheduling, or through the Frequency Office, Directorate of Range Operations.

AREA FREQUENCY COORDINATOR

The DOD Eastern Area Frequency Coordinator maintains extensive records of all DOD RF emitters licensed for use in Florida and located within 200 miles of Patrick AFB. This RF environmental file may be referred to by qualified range users.

FREQUENCY SURVEILLANCE, PROTECTION, AND ELECTROMAGNETIC MEASUREMENTS AND ANALYSIS (EMA)

The ETR has mobile ground monitoring FCA/EMA equipment. Surveillance is maintained of applicable portions of the frequency spectrum to preclude interference to frequencies used in support of missile/space operations. Monitoring is also performed to detect, locate, and alleviate interference, should it occur during an operation. FCA/EMA service/support is available to range users and can be obtained per RCEI 30-1. Specific capabilities and functions provided are discussed below:

The purpose of FCA/EMA is to ensure interference-free operations, to supply information on possible interfering transmitters, and to monitor and report the operating characteristics of missile and ground support transmitters. Appropriate frequency bands are monitored to prevent interference to test operations and to ensure that ETR operational frequency assignments and schedules are maintained within their limits.

FCA-EMA facilities consist of a fixed station and mobile vans. The fixed station at Merritt Island provides covered storage for vans. The location of the FCA site at KSC as well as the eight frequency and interference measurements (FIM) sites, are shown on page 130.

Fixed Station

The Merritt Island fixed station is shown on page 131. The FCA/EMA fixed facility has a Radar Beacon Bench Checkout System which is a special purpose test set designed for rapidly testing C- and S-band radar beacons. It combines in one test console all of the functions necessary to measure missile beacon parameters in a controlled environment. This system is available to all range users on request.

Included in the mission of FCA/EMA is the analysis of new ETR equipment for compatibility with existing equipment. This is done in the Spectrum Utilization Measurements Laboratory in the FCA/EMA building at KSC and at the antenna test range at Patrick AFB.

FCA/EMA supports Environmental Health in conducting personnel radiation hazard surveys in the areas surrounding each transmitting site on the ETR. RF density measurements are also made in launch and service areas to guard against ordnance hazards and to determine electromagnetic compatibility.

The results are documented and distributed to agencies concerned, including recommendations and suggestions for eliminating or minimizing hazards.

Mobile Stations

Two mobile vans operating on the ETR are based on the Merritt Island fixed station. These mobile units are shown on page 131. They perform the FCA functions by providing triangulation and "chase" techniques in locating and suppressing electromagnetic interference, as well as monitoring all range instrumentation for signal quality analysis. The vans perform the following functions:

Signal analysis	Audio and graphic recording
Frequency measurements	Interference evaluation
Field intensity measurements	Direction finding
Power density measurements	

During a scheduled missile test, a van is set up at the FIM site associated with the launch pad in use. MOIS communications, timing, countdown, and power connections are provided. FIM sites are chosen

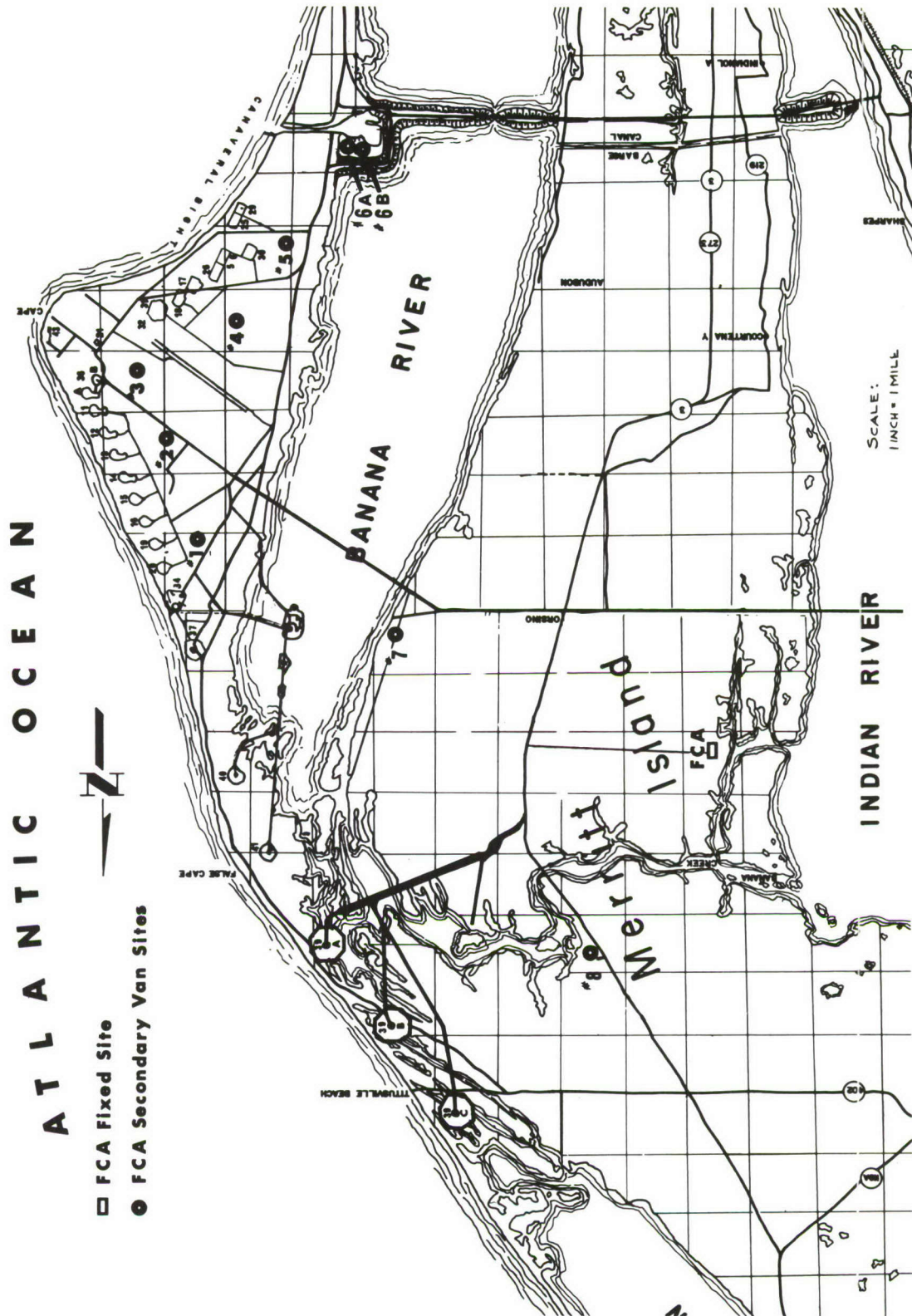

FREQUENCY CONTROL AND ANALYSIS

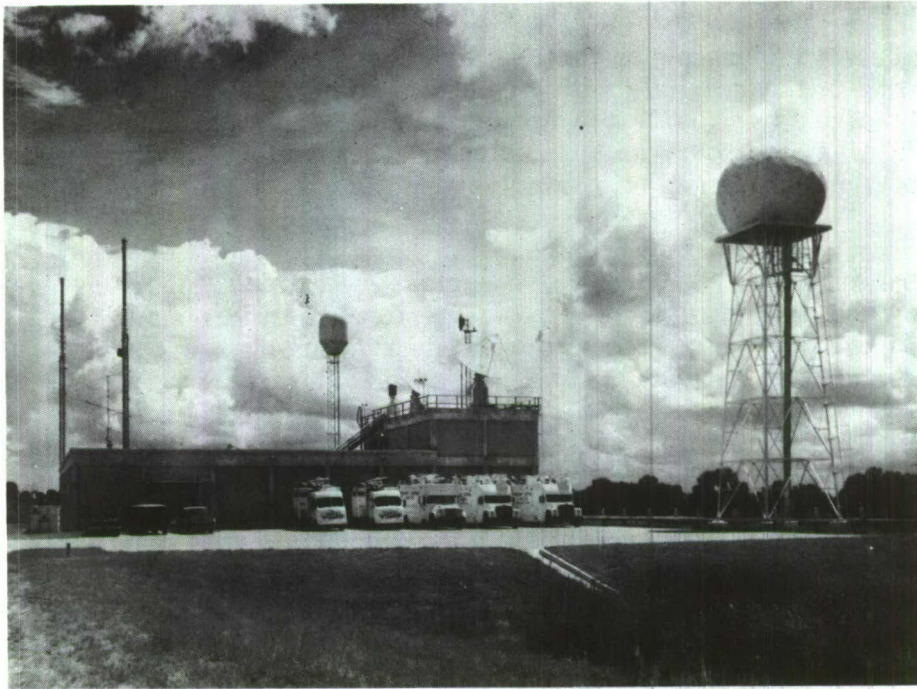

FCA FIXED FACILITY

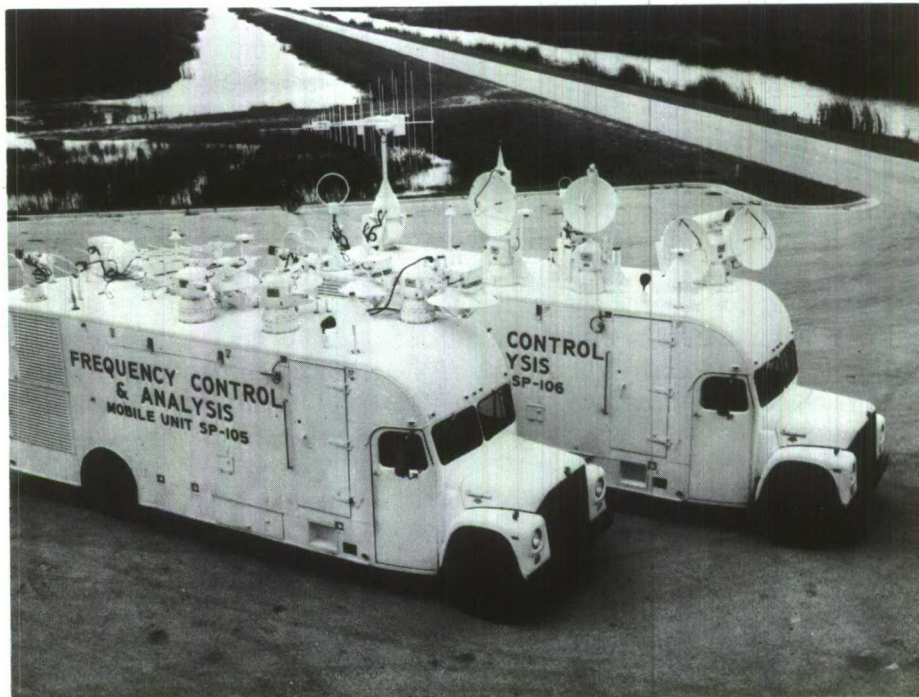

FCA VANS

for their direction finding and monitoring ability, depending on missile location. The vans may be moved at any time during the test to aid interference evaluation. HF/SSB communications and a self-contained power source are used when the van is located at remote sites.

A Radar Beacon Checkout System is presently operational in each of the vans. These systems are used to check out all missile beacons during countdown and are available to range users on request. The systems can measure sensitivity, peak power, pulse width, countdown, recovery time, delay, and pulse jitter of missile-installed beacons for ranges of 100 to 10,000 yards.

<u>Mobile Vans</u>	<u>Frequency Range</u>
Monitor	500 kHz to 16.0 GHz
Analysis	500 kHz to 16.0 GHz (+5%)
Direction finding	2 MHz to 16.0 GHz
Field intensity measurements	150 kHz to 16.0 GHz
Frequency measurements	750 kHz to 16.0 GHz (0.0001%-CW)

Two-way radio communications with fixed station
Recording:

		<u>Recorder Bandwidth</u>
Magnetic	7 channel	300 kHz
Graphic	8 channel	150 Hz
X-Y	1 channel	--

Radar Beacon Checkout System

<u>Parameter</u>	<u>Measurement Range/Accuracy</u>
Peak power output	-4 to +93 dbm + 2 db
Receiver sensitivity	-10 to -100 +2 db
Pulse width	0.2 to 2.5 μ sec +0.05 usec
Response delay	0.2 to 6 μ sec +0.015 usec
Recovery time	5 to 500 μ sec \pm 5%
Pulse jitter	0. to 0.6 μ sec \pm 0.015 usec

RANGE CONTROL CENTER

RCC

DESCRIPTION

The Range Control Center (RCC) is the central point from which the Eastern Test Range is supervised, controlled, and coordinated. The status of the various instrumentation systems is collected and displayed, allowing operators to make rapid and accurate decisions in support of launches, prelaunch test operations, and space flight missions. The displays in the RCC not only show the status of the Eastern Test Range instrumentation, but also the status of cooperating test ranges.

The Range Control Center consists of the following systems:

- RCC Instrumentation
(TV monitors, consoles, displays, plotters and recorders)
- Audio Communications
- Programmable Patching
- Weather Forecast Facility
- Main Frame Distribution
- Range Instrumentation Control System

RANGE CONTROL CENTER INSTRUMENTATION SYSTEM

The RCC contains equipment and displays to support simultaneous missions. From three main and four auxiliary operations areas, operators can control, direct, and reconfigure ETR resources to meet mission requirements.

Main Operations Areas

Operators at consoles in the two main operations areas direct the operation of the Range during launches and during combined missions with other test ranges. Remote status and trajectory display information, and timing inputs are available to all consoles for evaluation and posting on the status, trajectory, and timing displays.

Auxiliary Operations Areas

Four auxiliary control areas (network operations, orbital operations, test support and the command center) are used to control operations, other than launches, involving the ETR as well as other interrange agencies. Remote status and trajectory displays, console communications, timing inputs, plotting boards, teletype and TV monitors are available in the areas, depending on the function the area is serving.

The RCC also has a visitors' area for briefings on current range status and test progress.

RANGE CONTROL CENTER

AUDIO COMMUNICATIONS SYSTEM

Audio communications consists of direct line (green phone), network (Mitoc), console monitoring input, administrative telephone, local recording, aural countdown, local paging and announcing, and Cape aural warning systems.

PROGRAMMABLE PATCHING SYSTEM

This system makes possible rapid changes in voice communications support of range operations. By reading punched card instructions, it connects and disconnects incoming voice circuits to and from appropriate console keys where they activate headsets, handsets, or monitor speakers.

The major system components are:

- Programmable switch for point-to-point circuits (green phone)
- Programmable switch for network circuits (MOIS and Mitoc)
- Control console and peripheral equipment

WEATHER FORECAST FACILITY

The RCCs Weather Analysis System provides high wind, lightning, and heavy rain warnings; prepares diffusion forecasts of toxic fuels and radioactive materials; forecasts weather conditions for all launches; and provides weather service for recovery forces and instrumented aircraft on the AFETR.

MAIN FRAME DISTRIBUTION SYSTEM

This system receives all external inputs to the RCC and distributes these signals to the various displays.

RANGE INSTRUMENTATION CONTROL SYSTEM (RICS)

RICS is a digital supervisory control and communications system for rapid message exchange between Cape Kennedy and the stations at Grand Bahama, Grand Turk, and Antigua via the undersea cable, and Merritt Island facilities. A block diagram of RICS is shown on Page 135. The system accepts switch closures as inputs, converts these closures to digitally encoded messages, provides error detecting and correcting bits, and transfers the messages to the transmission system. At the addressed station(s), the messages are received, error detected and corrected, decoded, and the output presented in the form of latching relay contacts.

RICS has a self-test feature in the form of complementary test messages transmitted to downrange stations at discrete time intervals. The messages are transmitted back to Station 1 exactly as they are received. At Station 1 the received test messages are compared to those originally transmitted. If errors are detected, they are visually displayed and permanently recorded for postflight analysis and on-line corrective action.

RANGE CONTROL CENTER

Message Types

Critical discrete messages are of extreme importance and are transmitted with unique coding and repetition rate and assigned the highest priorities. Three messages are transmitted for each critical function requested. The bit pattern associated with a critical function is as dissimilar as possible.

Regular discrete messages are of normal importance and assigned priorities lower than the critical discrete messages.

Numerical messages are messages which contain information that cannot be conveyed by a single switch closure such as countdown and resume count messages. These messages are of normal importance and are assigned priorities equivalent to those of the regular discrete messages.

Automatic sustainer cutoff (Asco) is a special message and is handled in a unique manner - a tone is transmitted instead of a digital message. The receipt of the Asco signal from an external source causes a shift in tone frequency. Detection of this frequency shift causes a signal to be sent to the command/control transmitter with a timing accuracy of ± 1 msec.

Transmission Rates and Media

Station 1 can transmit 50 messages/sec to downrange stations. Each downrange station can transmit 20 messages/sec to Station 1.

One undersea cable channel is assigned to RICS for downrange traffic and one for uprange traffic. The uprange transmission system is frequency-multiplexed to allow the downrange stations to operate asynchronously.

INPUT/OUTPUT CAPABILITIES

<u>Message Type</u>	<u>Sta 1</u>		<u>Sta 3, 7, 9.1</u>	
	<u>Transmit</u>	<u>Receive</u>	<u>Transmit</u>	<u>Receive</u>
Regular discrete	900	820	240	255
Critical discrete	42	64	16	15
Numerical	10	16	4	5
Countdown	3	0	0	3
Resume count	3	0	0	3

In addition, output holding relays are provided as follows:

Station 1	400 relays
Station 3, 7, and 9.1	75 relays

REAL TIME DATA HANDLING

The ETR Real-Time Data Handling System supplies a variety of data to the Range and range users. This data includes vehicle performance and position for Range Safety, target acquisition messages for both local and downrange instrumentation, and critical data quality validation. The system is also used to recover data for postlaunch processing.

Previous sections have described the data handling subsystems of each data acquisition system. This section describes (1) how these subsystems form a data handling system and (2) some of the equipment which is unique to the system.

CAPE KENNEDY AND MAINLAND SITES

The Real-Time Data Handling System on the ETR is shown, in simplified form, on p. 137A. Page 137B shows the CKAFS and Mainland Data Handling System in more detail. The principal uses of the real-time data handling system are discussed below.

Presentation of Information To Range Safety

Two of the Range Safety systems, present position display and impact prediction, require extensive data handling equipment. Analog information is used for present position displays to provide system redundancy. This information may be converted to digital form for transmission. More precise digital data is used for impact prediction. (See Range Safety Section, Real-Time Impact Prediction.) Operational procedures prevent the same data source from being used for the two presentations.

The analog data is usually in polar form at the tracking instrument. A polar-to-Cartesian (P/C) converter converts this data to XYZ, referenced geographically to the site. The signals are then fed to a low-density data transmitter (LDDT) which digitizes each coordinate. The LDDT then keys a tone modulator to transmit the data.

The data transmitter outputs are fed to five low-density data receivers (LDDR) in the radar acquisition data distribution and control (Raddac) subsystem at Central Control.

The receiver outputs are patched, through switches, to analog computers which can perform up to 35 axis rotations and translations. (More rotations are available than receivers and plotting boards because nonorthogonal axes may be used, necessitating multiple rotations.)

Plotting boards provide the Range Safety Officer (RSO) with present position and impact prediction data. Each plotting board has two servo-driven arms which make ink plots on a 30 x 30-in. paper chart. Pens mounted in each arm can be

REAL-TIME DATA HANDLING

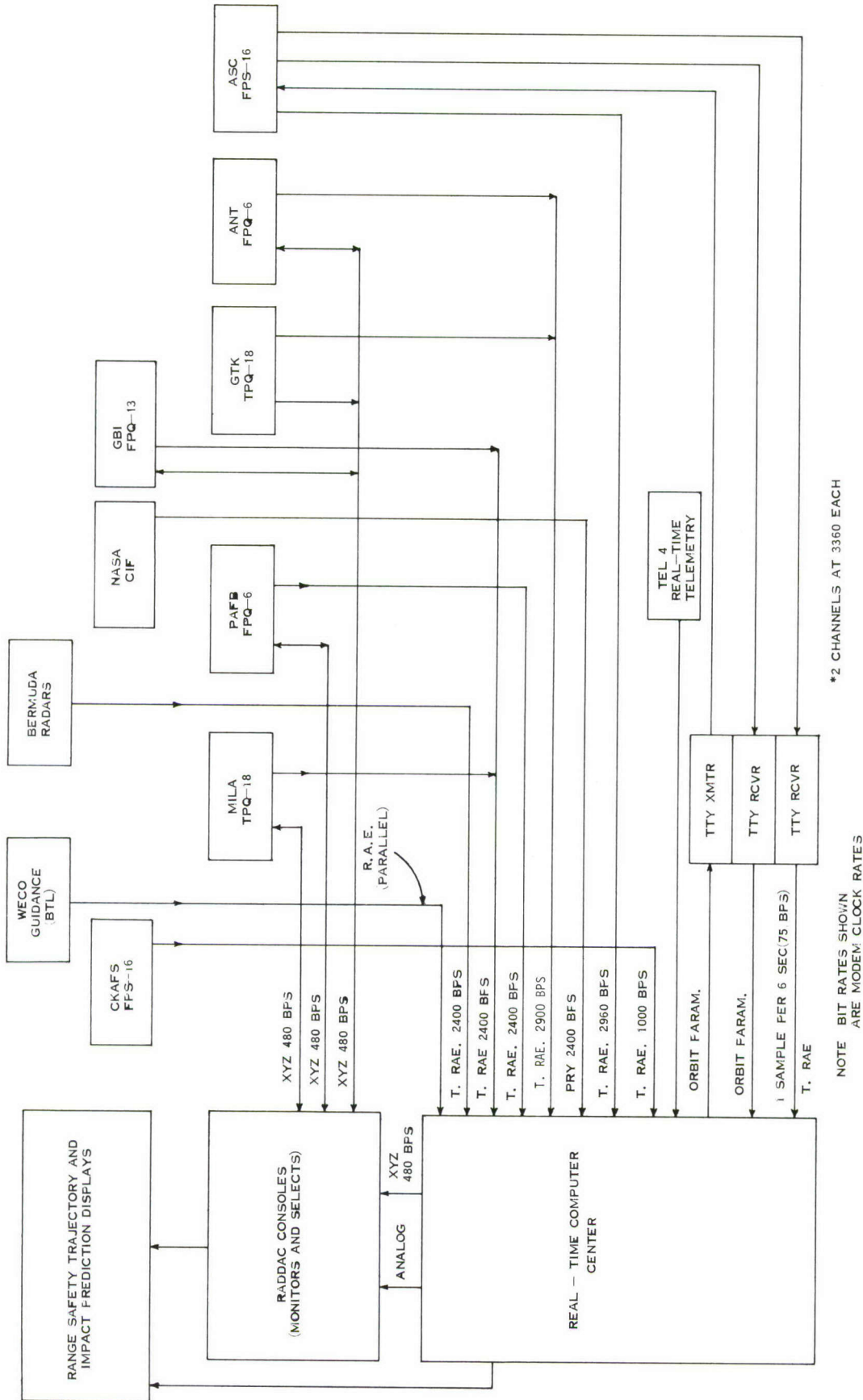

FIGURE 32 ETR SIMPLIFIED PRIMARY TRACKING DATA SYSTEM

REAL-TIME DATA HANDLING

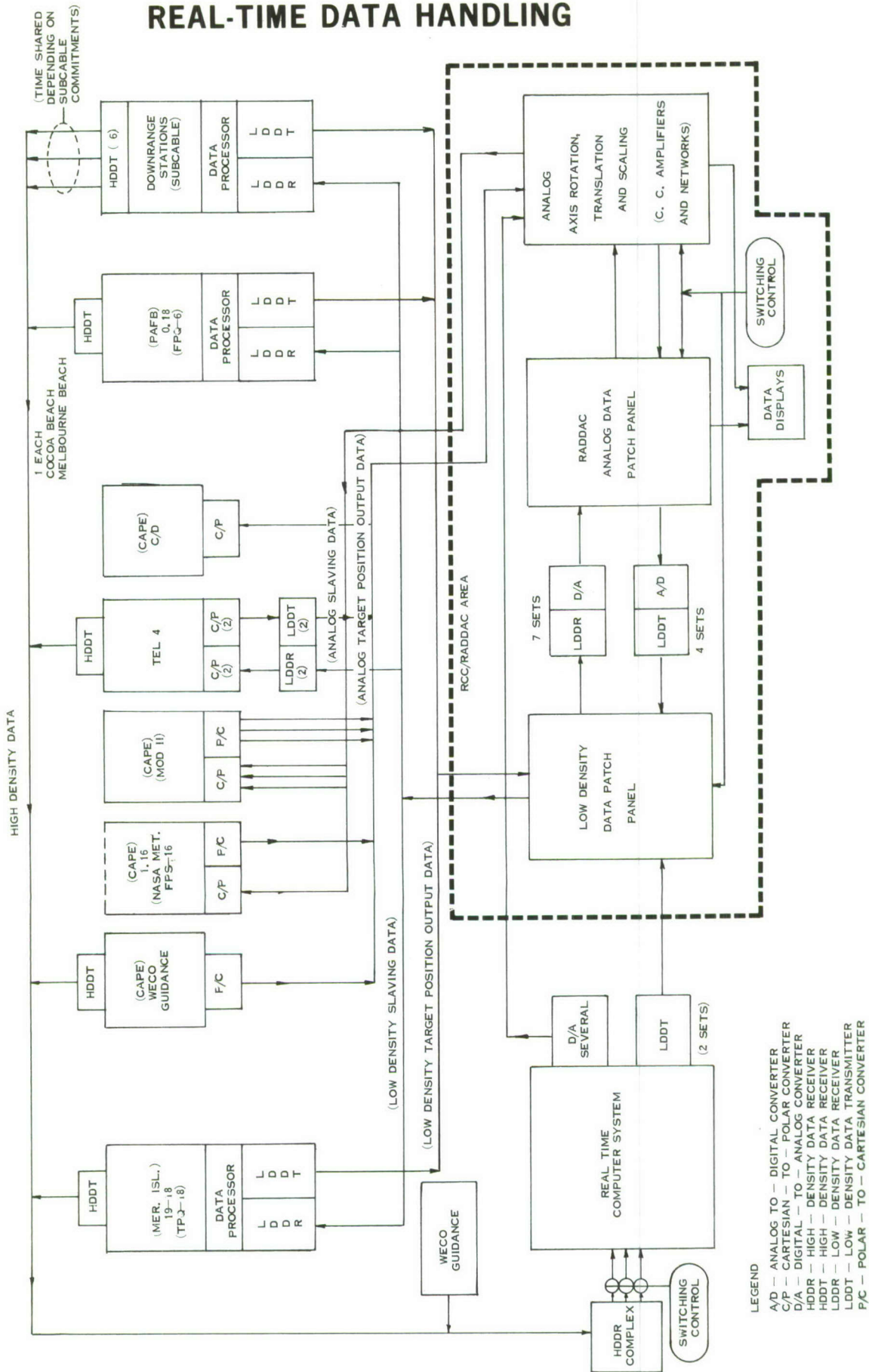

FIGURE 33 CAPE KENNEDY AND MAINLAND ACQUISITION BUS (SIMPLIFIED)

programmed independently to the axis rotation and translation computers. One of three sets of XY data can be selected by switches. The Present Position Display Controller (PPC), whose console is behind the RSO's, sets up and checks out the data sources associated with the range safety plotting boards. The priority and order of data sources for each plotting board is specified by Range Safety.

Display panels are available to the PPC to show the following:

- (1) The on-track status of all the data sources as they appear after validation by the data quality system.
- (2) The data source to be switched to the target acquisition bus.
- (3) The data sources available to the real-time digital computer, and which source has been selected by the computer.

The Impact Prediction (IP) System uses a separate and independent arrangement. Digital takeoffs on the acquisition instruments feed high-density data transmitters (HDDT) which sample their outputs at either 10 or 20 sps. This data must be transmitted to the real-time digital computer at Cape Kennedy. The data is recorded in modulated form at the source tracker and at the Real Time Computer System (RTCS). Data source selection is made by the RTCS which monitors data quality (see Data Quality Assurance subsection), on/off track, smoothness of data in use, and agreement/disagreement. The high density data receivers (HDDR) are at the RTCS, where appropriate high accuracy real-time computations are made, as discussed under Real-Time Computer System. Various modulation methods are used for high-density transmission with bit rates from 1,000 to 5,760 bps. No error detecting codes are used, though parity data is provided in most of the links.

Target Acquisition

The target acquisition system points electronic tracking instruments until they acquire track, and steers such nontracking instruments as cameras and command antennas. The system can be divided into two parts. One supplies information to sites (connected by wire or microwave) where simultaneous tracking with other instruments is possible. The other supplies acquisition information to remote sites (links by HF radio) where simultaneous track is not possible.

The local system uses a mainland fixed-origin bus for sites within 50 miles of Cape Kennedy, and a selectable-origin bus for more distant sites. The information on each bus is usually the same (that used to show target present position to Range Safety), the only difference being the apparent geographic origin of data. The output of the five LDDRs and the analog data from local sites are fed to analog computers for translation and rotation to common origins (up to seven origins may be used). The data source supplied to the two acquisition buses is determined by the Data Quality System. Up to 28 simultaneous separate outputs from the Data Quality and Acquisition Systems can be accommodated. Four may be digital and use the same type LDDTs described previously.

When the acquisition data is received at the instrumentation site, it is converted from common reference rectangular coordinates to site referenced polar coordinates by Cartesian to polar (C/P) converters. The information is then fed to the drive subsystems to point the antenna or camera.

The local acquisition bus thus ties together all uprange and subcable instruments. These instruments are spaced closely enough for overlapping coverage so that one is always on track. An instrument which is on track, as ascertained by the Data Quality System, continuously feeds acquisition data to the bus for other systems. In this way, track is handed from system to system down the undersea cable.

Acquisition information is supplied by HF radio, in teletype format, to sites not on the undersea cable (Ascension, Pretoria, and ships). Since the communications links cannot handle continuous information and the coverage from these stations does not overlap, a digital computer is used to generate tracking signals. Acquisition information is sent to these sites in the form of orbital parameters calculated by the real time digital computer at Cape Kennedy.

Data Quality Assurance

To insure that the data supplied to Range Safety and to instrumentation seeking the target is valid, a data quality assessment system is used. The operator uses the following information to validate the data.

1. Agreement/disagreement comparison -- The launch period is one of the most critical for data quality evaluation since the range safety problem is then most severe (remedial safety action can only be taken during powered flight), and since it is the time during which instrumentation seeks the target. The agreement/disagreement comparison indications furnish launch period information as to data quality.

2. Relative comparison of data -- The operator has five 30 x 30 in. plotting boards with pushbutton control to display data from any source. All data is presented to the same coordinates and scale, and the nominal or expected vehicle trajectory is preplotted. The operator determines quality of track by comparing the data in question with that from other instrumentation systems.

Data validation by the data quality system insures that only valid data is used for the acquisition buses by confirming the validity of the on/off track bit for each instrumentation source. If a green (on track) indication appears on an invalid data source, the operator forces it to a red (off track) indication. This validated on/off track indication aids in selecting the source to be used for the present position plot to Range Safety.

REAL-TIME DATA HANDLING

Transmission to Range Users

Real-time present position and velocity data is sent from the real-time computer to the Goddard Space Flight Center and Manned Space Flight Center at Houston. Present position information for acquisition and real-time trajectory plots is also distributed to Range Users at Cape Kennedy and acquisition information is sent to Range User equipment down range.

Data Recovery

Most of the electronic tracking instruments use magnetic tape recorders to record data (in transmission modulated form) and Range time at the site. Stripchart recorders are used to record servo tracking error signals, AGC voltage, Range time and operation events such as transmitter-on and beacon track.

The data used to compute impact prediction is recorded at the CKAFS Real-Time Computer System in computer compatible format. Data from local tracking instruments on the Florida mainland and from selected tracking instruments on the undersea cable is also recorded in transmission modulated form at the RTCS and for post-flight at the Patrick AFB Data Processing Center.

Other downrange data is transmitted over the undersea cable after launch, or sent to Patrick AFB by the first available transportation.

DOWNRANGE SITES

A target acquisition bus is used to transmit acquisition data generated by the Real-Time Computer System to all downrange stations located on the undersea cable.

A special problem exists at Ascension, Pretoria, and ship stations. Since these sites are too far from the uprange radars to provide overlapping coverage, they must be sent predicted target position data geographically referenced to their own area. This data must be time correlated and accurate enough to assure target acquisition by the remote sites. Usually, the only link providing target acquisition information to these sites is a radioteletype channel from the Cape computer or another computer.

Each site has a digital computer to receive time vector orbital descriptions of the target and convert them to predicted real-time target position data in local geographical reference. Once the radar has locked on to the target, the computer uses the new radar data to update the orbital description and provide improved local target designation data. The corrected orbital description is forwarded to other remote sites via teletype.

The data handling systems aboard various ships and aircrafts are discussed in the Ships and Aircraft section.

REAL-TIME DATA HANDLING

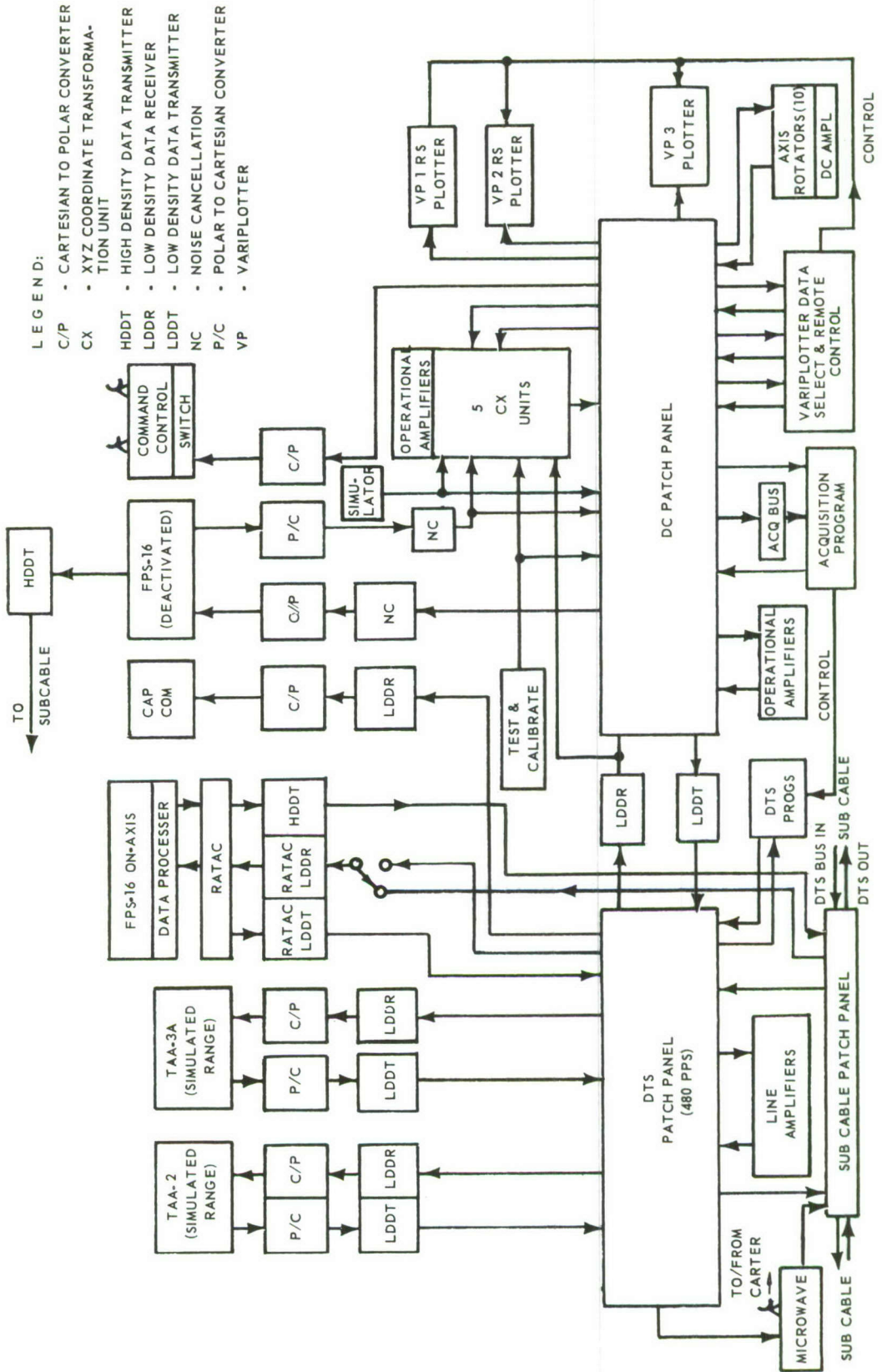

FIGURE 34 GBI ACQUISITION SYSTEM

REAL-TIME DATA HANDLING

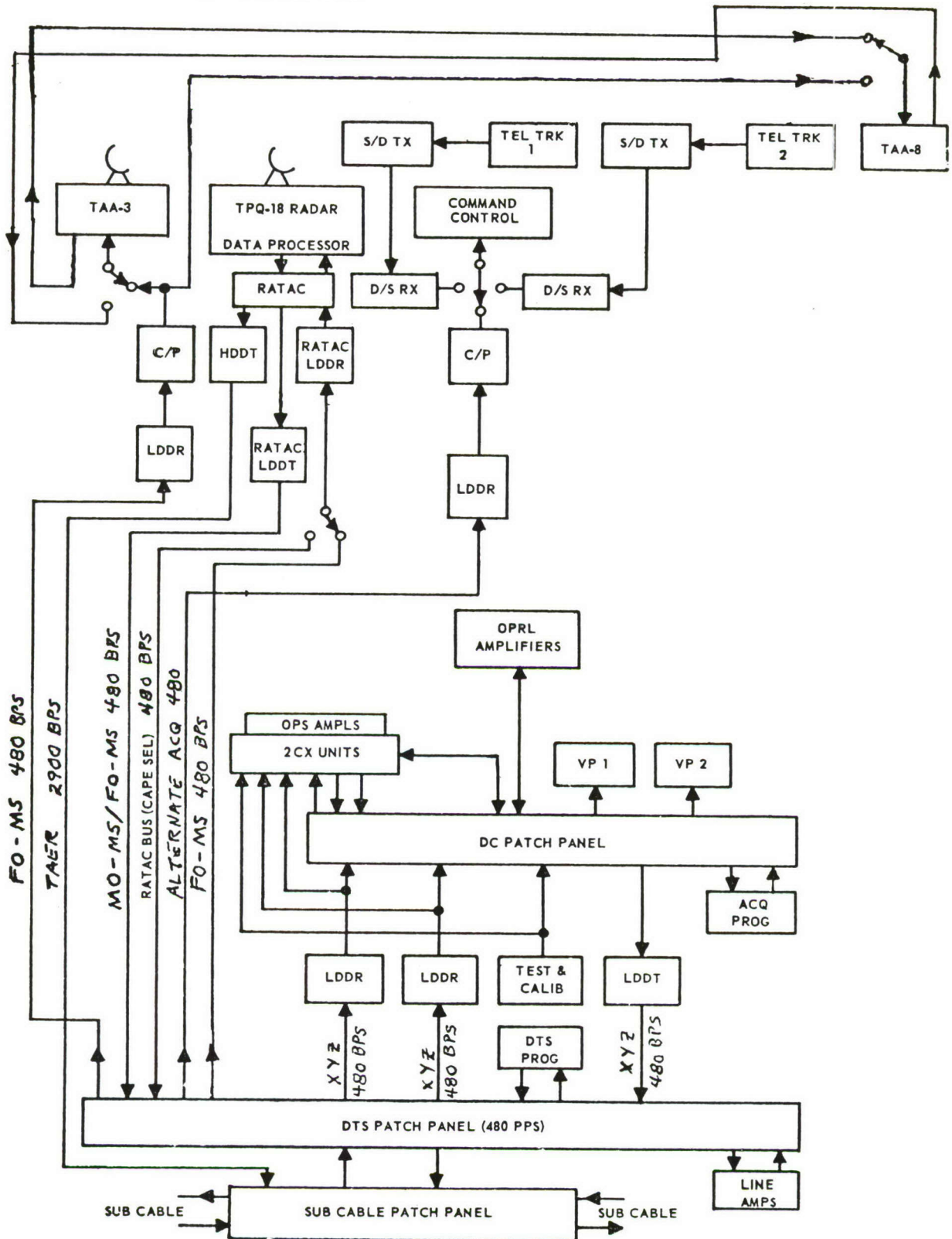

FIGURE 35 GRAND TURK ACQUISITION SYSTEM

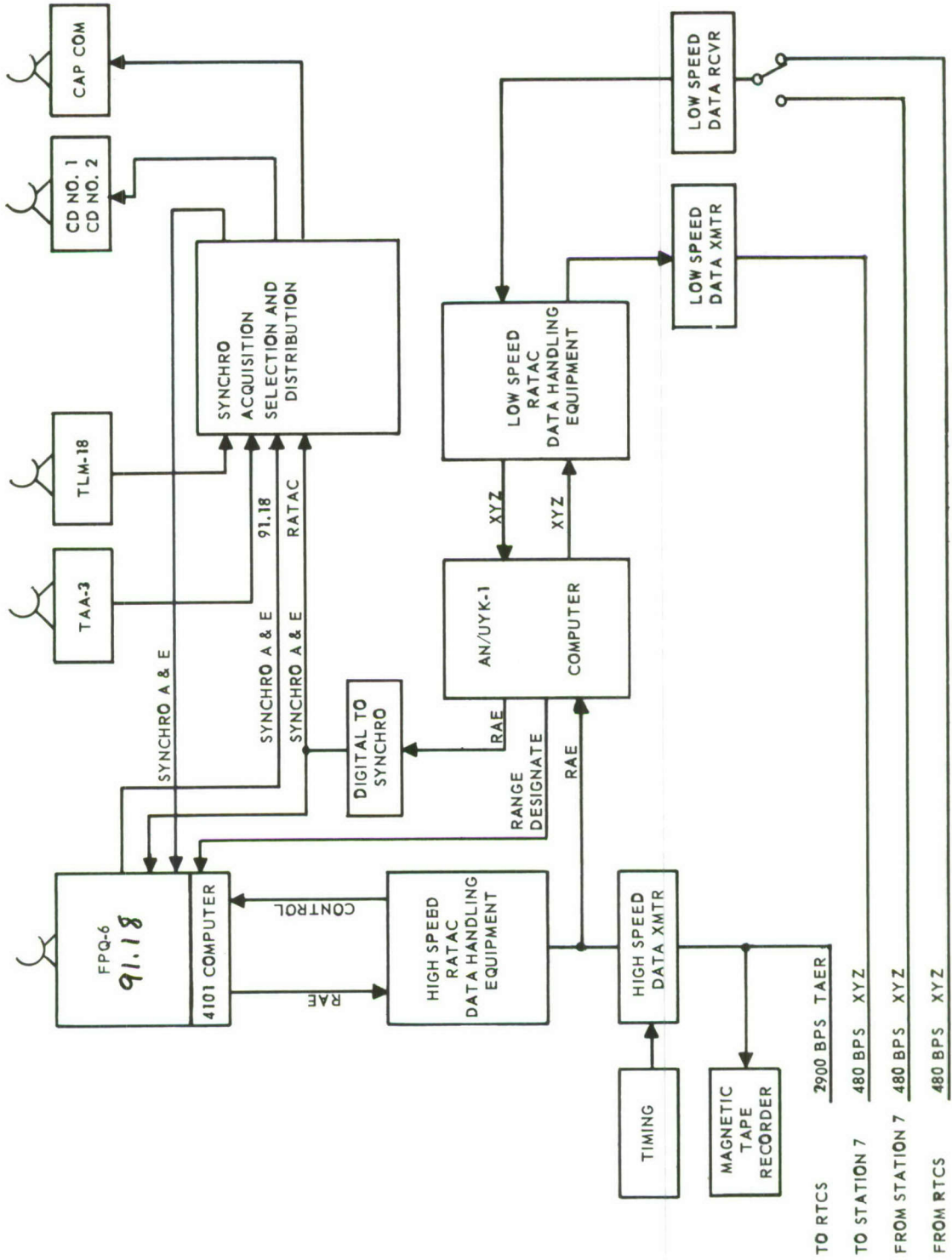

FIGURE 36 ANTIGUA ACQUISITION SYSTEMS

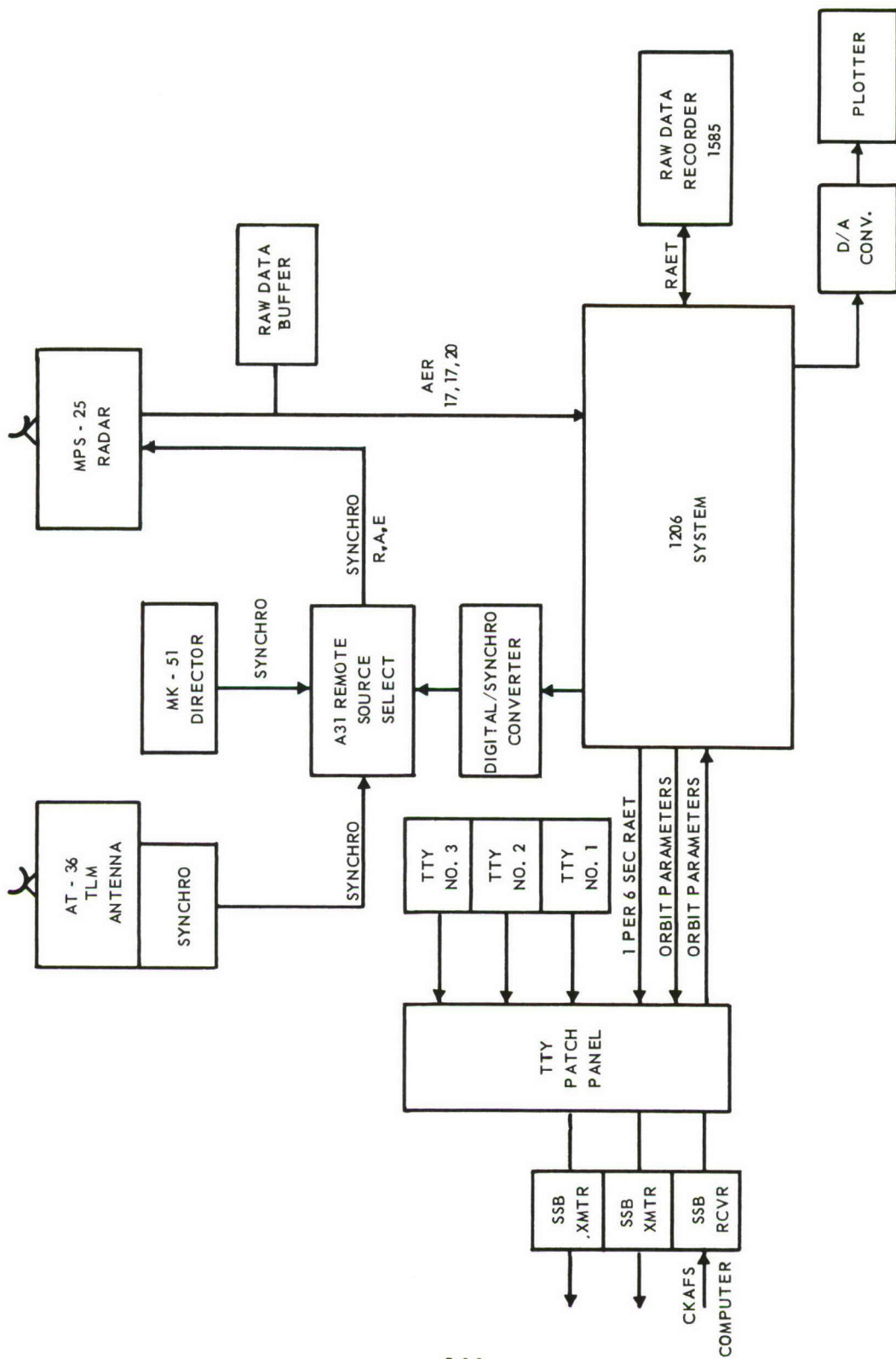

FIGURE 37 PRETORIA ACQUISITION SYSTEM

REAL-TIME DATA HANDLING

Polar-to-Cartesian (P/C) Coordinate Conversion

The target information (azimuth, elevation and slant range) produced by the radars is in polar coordinates. The polar-to-Cartesian coordinate equipment converts this information into rectangular coordinate form.

Cartesian-to-Polar (C/P) Coordinate Conversion

This equipment accepts analog voltages representing the X, Y, and Z coordinates from other sources, or from data transmission system equipment, and converts this into equivalent polar information: azimuth, elevation, and range. The polar data is usually displayed on illuminated indicators and is supplied to the radar as synchro information.

Low-Density Data Transmitter (LDDT)

The LDDT converts three Cartesian coordinates (X, Y, and Z) into a serial binary pulse train pattern suitable for transmission to a remote receiver over a telephone line. The transmitter produces 10 complete frames of information each second. Each frame is divided into 48 time slots. Intelligence is carried by the presence or absence of a tone burst in each slot. The tone bursts are sinusoidally shaped to minimize the bandwidth needed for data transmission. Each coordinate channel is represented by 13 binary bits; hence, 39 of the 48 bits are assigned to analog information. Six auxiliary yes-no bits are interspaced according to six off-on control functions supplied to the transmitter. The remaining three time slots are used to designate the end of a word and subsync.

In the transmitters having analog inputs, the three analog voltages (varying between ± 140 v) are converted into digital data by dc amplifiers whose feedback networks are controlled by multiple relay closures. Each relay closure represents a binary weight somewhere between 1 and 4,096. By measuring the difference between the dc analog voltage and a fixed reference generated with the transmitter, the correct relay closures are performed. The data corresponding to these relay closures is subsequently transmitted in the form of a code word.

The digital output consists of 10 sps of the 48-bit code word. Each output pulse has a 1,920 Hz tone burst of 2.08 msec duration. The end of each digital word is marked by 4.16-msec tone burst which synchronizes the receiver with the transmitter. The output voltage is adjustable from 0 to 40 v, peak-to-peak across a 600-ohm load.

Low-Density Data Receiver (LDDR)

The LDDR converts the serial pulse train pattern representing three Cartesian coordinates and six control functions into three corresponding varying digital or analog quantities and six auxiliary pulses to operate external relays.

High-Density Data Transmission Equipment (HDDT, HDDR)

Several types of digital data transmission systems are used on the ETR to transmit precision digital data from electronic instrumentation. All have the same function; however, they differ in bit transmission rate and in the type of multiplexing and modulation used in the circuitry. The HDDRs are located at the RTCS, along with magnetic recording and playback equipment.

FPS-16 Radar Data Transmission

A 1,000 bps data transmission system (over 3-kHz bandwidth communication lines) has been used since 1958 to transmit FPS-16 radar data. The data transmitter supplies 250 pps shift pulses and 10 pps read pulses to the radar shift circuitry. Data is sent simultaneously over three output lines from the radar shift registers so that the 21 bits of range, 18 bits of azimuth, and 18 bits of elevation information are transmitted serially, least significant bit first. The azimuth and elevation bits are delayed so that the most significant bits in R, A, and E are grouped together.

The three data streams enter the transmitter in parallel and are shifted out serially (so that the data is interlaced) to a data keyer which operates a 2-kHz tone burst generator. This tone burst is passed to a filter whose frequency characteristic can be approximated by a $(\sin x)/x$ function. The resulting signal is one cycle of an amplitude modulated, 2-kHz tone.

Provision is made in the data chassis to insert four auxiliary data bits into the vacant time slots following the first and second least significant range data bits.

The transmission system is normally synchronized with range timing. In the event of timing failure, the necessary timing signals can be generated in the transmitter by an oscillator and frequency dividing system.

The bandwidth needed in the communications circuit is approximately 1,000 to 3,000 Hz. Equalization is needed to correct relative delay distortion. The data receiver accepts the tone modulated data, detects the information, arranges its format, and feeds it to an output buffer as three separate words.

Precision Radar Data Transmission

The data handling system for the AN/FPQ-6 and AN/TPQ-18 radars incorporates vestigial sideband data transmission handling 2,900 bps serially over a nominal 3-kHz wire transmission circuit. This transmission system is essentially an amplitude modulation system with the upper sideband suppressed and the carrier partially suppressed. Delay equalization is necessary, and provided for each receiver.

The transmitter will accept either return-to-zero (RZ) or non-return-to-zero (NRZ) signals. A data converter accepts NRZ signals and pulses from an internal clock and converts these to RZ form. For RZ input signals, the data converter is bypassed. The RZ signal is supplied to a bistable multivibrator which causes it

REAL-TIME DATA HANDLING

to change state for each "one". This is passed through a low-pass filter and then through a shorted delay line which further band limits the signal by producing an approximation of a $(\sin x)/x$ pulse. This latter signal is used to modulate the output of a subcarrier generator producing a double sideband signal which is passed through a low-pass filter to produce a vestigial single-sideband signal. This signal is then impressed upon the communication line by a line driver.

The data transmitter buffer accepts serial range (25 bits), azimuth (19 bits), and elevation (19 bits) over three lines from the radar. A terminal timing unit also supplies a 21-bit time code and 10 or 20-pps timing pulses. The full 144 bits of data samples are transmitted so that 60 bits are available at the transmitter to introduce auxiliary functions such as station identification, vehicle identification, radar optional bit, beacon/skin, autotrack, sync, and start-of-word. The data is transmitted in serial form.

At the receiver, the signal noise is reduced by a bandpass filter and then amplified for a constant output to a line equalizer to correct the delay distortion introduced by the communication line. This signal is then phase shifted ± 45 deg and the two phases are demodulated and added. A low-pass filter removes any residual carrier. This signal is supplied to a phase splitter for 180-deg inversion and, with the inverted signal, supplied to a detector so the negative wave portions are made positive. The detector output also supplies sampling information to an automatic frequency control circuit to synchronize the timing generator to the data rate. The timing generator furnishes the output timing signal sampling information for the sample gate and shift pulses for the data converter. The sample gate, upon coincidence of a data pulse and sample pulse, will produce an impulse data signal, converted to the NRZ form by a data converter.

The receiver presents TAER as serial words. An end-of-message pulse is delivered on a separate line to signal other equipment that the data is ready to be read. The serial data is accumulated in the computer holding register. In addition to the 2900 bps HDDT system, a 2400 bps system (MIL-STD-188B) is implemented at the Merritt Island AN/TPQ-18, and at the PAFB AN/FPQ-6 radars. This system incorporates an I/O buffer to provide the interface between the RCA 4101 processor at each site and secure communications equipment. The output of the communications equipment is fed to a standard 2400 bps wire line modem (AN/GSC-20) for transmission to the CKAFS.

The receiver at the Cape X-Y building accepts data and clock which are decrypted and transmitted to the RTCS over secure transmission lines. At the RTCS, the 2400 bps data are fed to data lock equipment which receives the data and clock, provides frame synchronization, and inputs to the data to the real time computer holding registers.

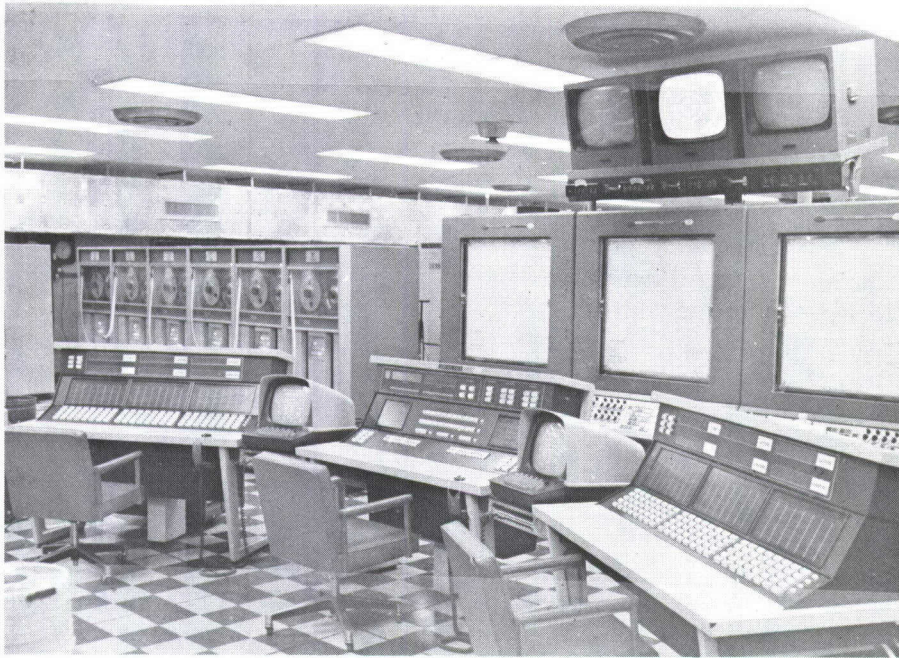

CDC 3600 Computer

RADDAC

Raddac (radar acquisition data distribution and control) is located in the Range Safety operations room at the Range Control Center. It contains analog computing elements (highly stable dc amplifiers configured as summing and multiplier devices) which isolate, scale, translate, and rotate Cartesian target position data. This data is provided to the Range Safety plotting boards, the

REAL-TIME DATA HANDLING

Raddac data evaluation plotting boards, and the target acquisition bus.

Raddac controls the target acquisition bus for tracking sites on the mainland and downrange on the undersea cable. For major operations, target position data is provided from the RTCS as well as directly from source trackers. For missions not involving trajectory prediction, such as cruise missiles, aircraft support tests, and acquisition system checkouts, Raddac can operate independently of the RTCS.

Inputs to the system consist of approximately 11 mainland radar, CW, and telemetry sources, and five LDDRs which, on a time shared basis, accept target position data from all sources having real-time data links to the Cape (except Udop, GE Mod III, and WECO guidance data; the computer will use only one of these sources at one time.) During operations involving the RTCS, target position data is computed from high density data (from the same sources selected by the computer for Range Safety computations) and is fed to Raddac through analog and low-density digital links.

Outputs from the system (Cartesian XYZ data) consist of the following:

- (1) Target position data scaled, centered, and rotated for Range Safety display on standard charts.
- (2) Target position data scaled, centered, and rotated to standard geographic conventions for the acquisition bus used by mainland and downrange stations in acquiring and maintaining normal track of the target.
- (3) Target position data in special Cartesian coordinates for the Range Control Center, aircraft and recovery controller plotting boards, and range user blockhouse displays.
- (4) Simulated target position data for checking out data links to displays or to mainland and downrange tracker slave servomechanisms. Output data can be transmitted through LDDTs and by dc output line amplifiers.

Raddac contains the following devices:

- (1) Operational amplifiers (about 500 units) with multipliers and summing networks.
- (2) Axis rotation units (about 35).
- (3) Relay switch banks which route target position data through semi-permanent patch panels under console pushbutton programming control.
- (4) Radar simulator, a console conversion device which transmits the Cartesian equivalent of manually entered angles and range; recorders for tone data and events; and precision null voltage test sets for checking and calibrating the system.

REAL-TIME DATA HANDLING

(5) A console with audio line equipment for voice contact between operator and voice networks and data switch/indicators. The console faces several plotting boards on which the operator observes the relative behavior of real time target position data. The plots are visually compared to one another and to theoretical plots drawn on the charts before the flight.

(6) Auxiliary Raddac console is located directly behind the Raddac console. The radar coordinator uses this console as a communications point for checking out radars before all flights, and coordinating handover of the target from one radar to another during flight. Since the coordinator can monitor the instrumentation voice networks while observing plots and status from the various radars, he can assist in providing best real time deployment of the radars.

Raddac Operator

The Raddac operator performs the following functions:

(1) Insures that the Range Safety real time target position data is valid. When the valid data is forwarded through Raddac to the Range Safety display area, priority relay logic equipment automatically selects highest priority data for plotting board display. Priority is preset for each mission, but can be changed manually by the present position controller or the Range Safety officer.

(2) Selects the best source of valid data (by pushbutton switching) to feed the acquisition bus. This decision is based on a prelaunch schedule, real time on track status data, verbal contact with radar operators, and relative data comparison, as described under Data Quality Assurance.

(3) Works with the radar coordinator in assuring that each radar is normally tracking the proper target. For instance, if one radar shows a plot on a target that is different from two or more sources showing plot agreement, that radar will be returned to slave mode to correct the ambiguous condition. When the condition is corrected, the radar can resume normal track.

REAL-TIME COMPUTER SYSTEM (RTCS)

The Real-Time Computer System is designed to be used primarily for impact prediction for Range Safety operations on the AFETR and for orbital support. The RTCS consists of two Control Data Corporation (CDC) 3600 computers and two CDC 3100 computers.

The system accepts data from the Range sensor, calculates the course of a missile or space vehicle, and plots the instantaneous impact point (IIP) on the assumption of missile thrust termination at that instant. The plot provides

REAL-TIME DATA HANDLING

the Range Safety Officer with the necessary information for a decision to continue or to abort the mission. In addition to plotting IIP, the system provides immediate postflight computations for vehicle recovery, downrange radar acquisition data, and quick look data reduction.

With their high speed and flexibility, the two 3600 computers can also be used independently in an off-line mode to solve nonreal-time problems, such as large scale data processing and scientific applications.

The 3100 computers provide the control and intermediate storage for teletype input/output and also provides the storage and control for driving the Range Control Center projection system and the cathode ray tube display associated with the Launch Area Recovery System.

The RTCS hardware can be described in five logical subsystem: Compute, satellite, input, output and control.

Compute Subsystem

The compute subsystem is based on two CDC 3600 computers. The 3600 computer is a high speed, solid state, general purpose data processor. Each CDC 3600 in the RTCS has a compute module which performs the arithmetic and logic operation; one memory module of forty-eight thousand 51 bit words; and interchange module which uses four 12 bit data channels (Computer B only, Computer A uses two 12 bit data channels) and two 48 bit data channels; and an operator's console. Each storage module is connected to both computer modules, making 96,000 words of storage available to each computer system. This storage is normally separated under program control so each compute module has 48,000 words of private storage. Each subsystem also contains line printers, card readers, and a typewriter. Both computers share a bank of 18 magnetic tape units. All 18 units are available to either computer under program control and two of the 18 are switchable to a 3100 computer. The tape units use standard 1/2 inch magnetic tape at either low or high density. Normally, high density (556 bits/inch) is used which allows a transmission rate of 83.4 kHz. Tapes are recorded on CDC 606 transports. The particular configuration in the RTCS for magnetic tape storage allows each computer to operate simultaneously with two of the transports.

Both 3600 computers are connected to the CDC 3100 satellite computer through a satellite coupler.

Satellite Subsystem

The satellite subsystem consists of two CDC 3100 satellite computers. Each 3100 has a compute module, a memory module of 32,000 words, a control console, four 12 bit communication channels, line printer, card reader, card

REAL-TIME DATA HANDLING

punch, paper tape reader punch, D/A converter (eight analog channels), eight teletype input/output channels, and four magnetic tape units. Two of these magnetic tape units are switchable between the 3100 and 3600s.

Input Subsystem

The input subsystem for the RTCS is shown on Page 154. This subsystem receives the tracking data from various range sensors and processes it to be compatible with the computer subsystem. It also provides the interface connections necessary to enter this data directly into the memories of the two computers. The input interface consists of 50 input holding registers (serial and parallel), two data pyramids, two parity generators, two address generators, two address parity generators, and two scanner units.

The input registers receive and store data words from the C-band radar group, Kineplex, 1002 receiver group, master control console, WECO receiver, Bermuda radars, Wallops Island radars, Odop CIF, telemetry, and the time buffer. In addition, inputs are received by the special control word register.

The FM 1002 and Ratac (C-band tracking group) registers receive serial trains of data pulses from the input receiver group before transmission to the storage module. The Ratac registers receive four words every 50 msec period. The 1002 registers receive one word every 100 msec period. The 1002 and Ratac registers can also receive parallel data if such data is accompanied by clear and set enables.

The Bermuda and Wallops Island radar data is received by Bell 205 data modems at a 2400 bps rate. These serial data trains are synchronized and fed to the input interface by data lock units. The Odop CIF data is received by a Bell 201A modem at a 2000 bps rate and is also interfaced with a data lock unit.

The remaining registers - master control console register, WECO register, Kineplex register, telemetry register, spare status register, and special control register, receive parallel data and act as buffers between the storage module and the data source equipment. The source status register indicates the latest data from the WECO, Ratac, telemetry, Kineplex, and 1002 registers. The time buffer interfaces directly with the data pyramids and does not require a register to store the data before the data is transmitted to the storage module. The outputs of the registers are gated into the data pyramids by the respective scanners associated with the A or B computer input interface subsystem. The scanner interrogates all input registers each cycle. The scanner continuously checks the input register for a data ready signal, and upon receipt, stops and transmits a signal to the address generator, data pyramid, input register, and the storage module.

The storage module acknowledges the data input with a resume signal which causes the scanner to continue the check of the input registers. The address generator transmits a 15 bit address to the storage module. For all registers, except

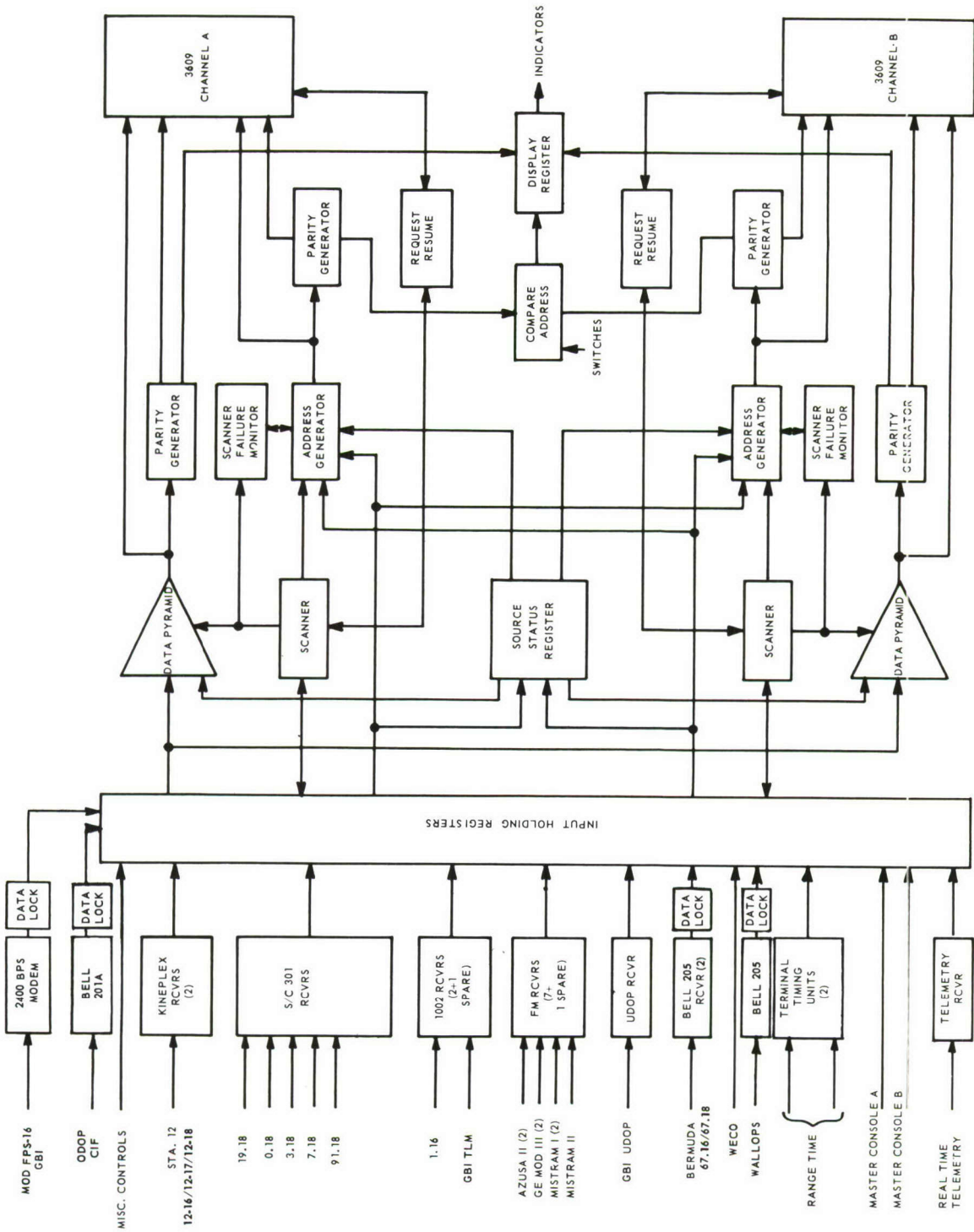

NOTE: * ONLY ONE INPUTTED TO INPUT HOLDING REGISTER

FIGURE 39 INPUT INTERFACE LOGIC BLOCK DIAGRAM

REAL-TIME DATA HANDLING

telemetry, the address is determined by the interrogate position of the scanner, the appropriate bit in the source status word register, and the number of the word (0 through 3) presently in the input register. The telemetry address is determined by the telemetry computer and the interrogate position of the scanner.

Analog tape recorders are also provided in this subsystem to record the data in raw form before processing. This allows the users of the system to record selected source data for further analysis after the Range Safety cycle is completed. It also provides a convenient means of checking out the system before real-time operation by playing back either test pattern data or previously recorded data and operating the system as a simulated real-time activity.

Output Subsystem

The output subsystem receives real-time output from the computer group. It distributes and transmits the data to the Range Safety Officer, the Range Control Center (orbital support data), range sensors, the Goddard and the Houston Space Facilities, and Barrel I. In addition, teletype facilities are provided to allow the computers to send and receive messages from the Cape Communications Center. The output subsystem equipment is divided into five groups: digital, analog, teletype, Houston buffer (Gemini and Apollo controller), and Barrel I.

The digital output equipment receives 48-bit parallel output words from the computer group. The output data words are distributed and buffered into the 480 pps transmitters which transmit target acquisition data to downrange stations. Also, digital output equipment sends relay closure signals to the Range Safety Officer, equipment and program status indications to the Range Control Center, and control signals to the input subsystem. The digital output equipment contains two distributors, thus providing the capability of supporting two missions simultaneously. The telemetry simulator provides telemetry program development and telemetry data simulation.

The analog output equipment receives 48-bit digital input words from the computer group and converts each digital input word into three analog output voltages. Outputs from the analog equipment are distributed to three X-Y recorders in the RTCS building and to either three or four remote X-Y recorders in the Range Control Center used for plotting IIP and present position data. The analog output equipment also provides relay closure signals for digital-to-analog (D/A) and X-Y recorder control.

The teletype equipment provides five teletype channels for communication between the ETR/RTCS and the Cape Communications Center. Standard 5-bit serial teletype characters are received from the Cape Communications Center and converted into parallel binary words for placement into the computer memory. The teletype system also receives output words from the computer. These are converted to standard teletype characters and transmitted to the Cape Communications Center.

The teletype circuit patch configuration between computer teletype transmitters and receivers, the communications control building, various range user sites, and the RTCS teletype equipment complex is established, monitored, and controlled by the

REAL-TIME DATA HANDLING

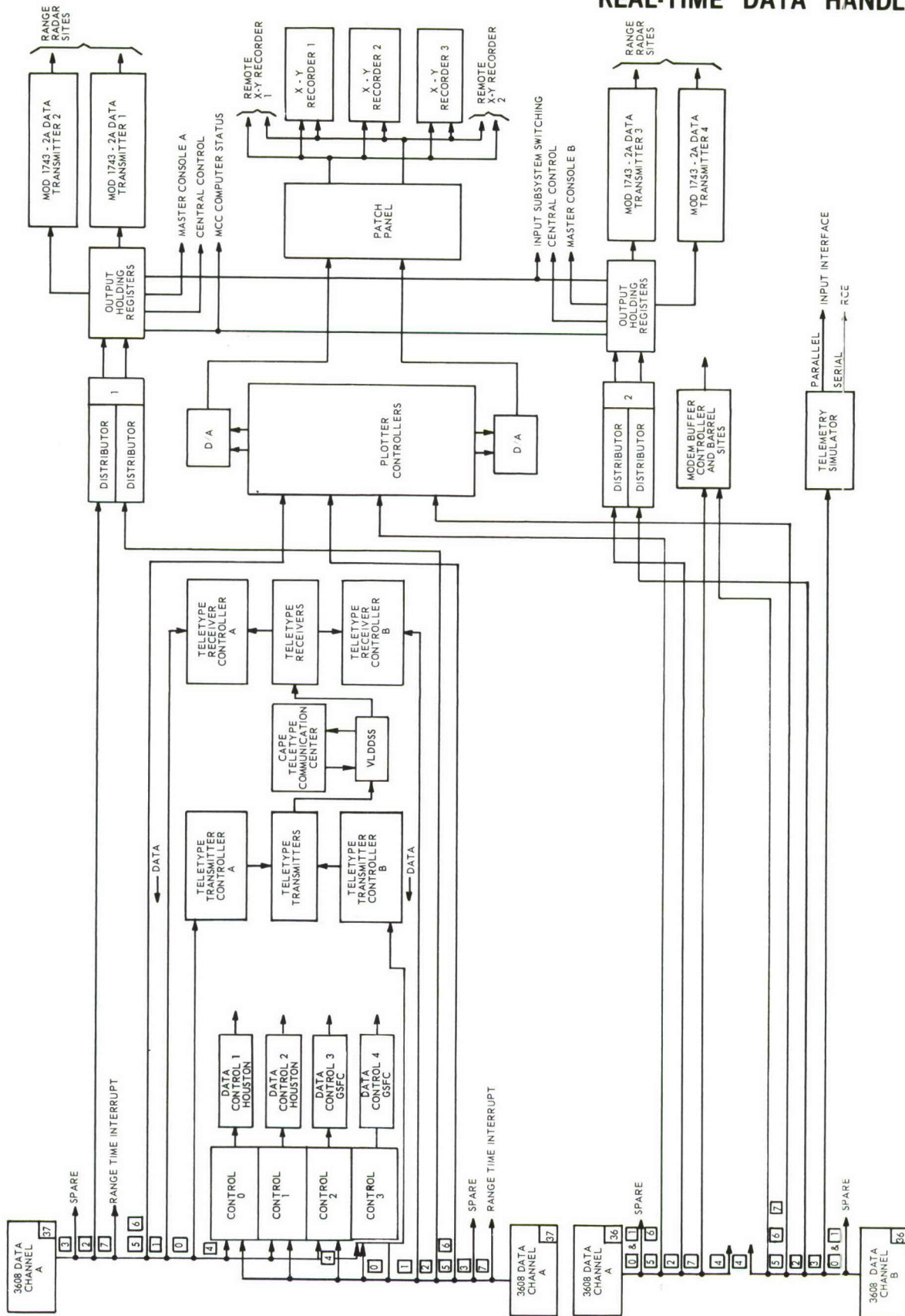

FIGURE 40 OUTPUT SUBSYSTEM BLOCK DIAGRAM

REAL-TIME DATA HANDLING

Very Low Density Data Switching System (VLDDSS).

The Data Control Unit (DCU) buffers connect the RTCS to the NASA Manned Space Flight Center, Houston. The buffers operate under control of the output program and contain four controllers which buffer 36-bit data words to four DCUs for transmission to Houston and Goddard.

The Barrel I System receives 48-bit digital words from the computer group. It transmits this data to a range site at 2900 bits per second.

Control Subsystem

The control group provides overall manual and automatic system control during real-time application of the RTCS. It synchronizes the operation of the two computers in the compute group, selects computer operating modes, and synchronizes the operation of the two computers with range time.

The control group consists of a Master Control Console (MCC) and a control logic module. The MCC contains the switches and indicators required to manually communicate with and control the two 3600 computers during a real-time application. The control logic module contains the switchover, memory lockout, and range time interrupt logic units. These logic units operate in conjunction with the MCC to control the operation of the two 3600 computers. Page shows a simplified block diagram of the control group.

The MCC provides manual real-time control of the RTCS. It displays the status of the tracking sources, the status and operating mode of the computers, the status of the backup equipment, the connect status of all equipment on the 3608 data channels, and the mission status. The console contains controls to manually select system and computer operating modes, switch in backup equipment, and manually select a tracking source for impact prediction calculations.

The MCC communicates with the two computers by setting flip-flops in the holding registers located in the input interface module when switch/indicators on the MCC are depressed. This data is transferred into the computer memory modules by the input interface logic and is interpreted by the program in the computer. The computer program also sends replies and equipment status indications to the MCC by setting flip-flops in the output registers located in the output interface module. The outputs of these registers illuminate the MCC displays and indicators. The MCC communicates directly with the logic in the input interface module.

The MCC consists of three bays. The left- and right-hand bays are identical and display 24 input data sources. Six digital indicator groups in each outside bay display numerical data. Six switches are also provided, one of which designates the outside console in use during a mission.

The center bay of the console contains computer status, switchover unit status, system disconnects, a memory lockout register, standby unit selection, two key-sets, two connect status displays, and computer mode selection switches.

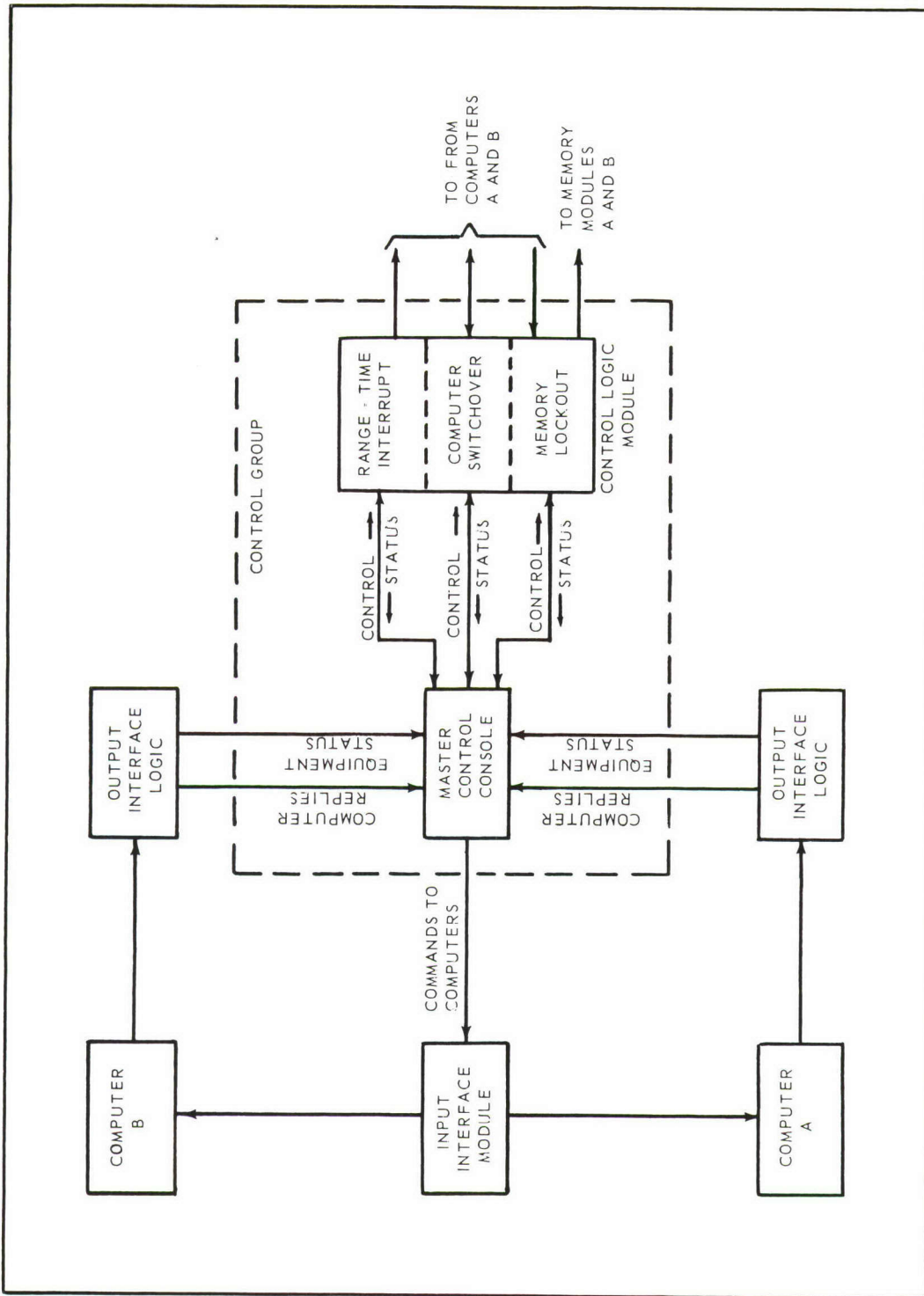

FIGURE 41 CONTROL GROUP BLOCK DIAGRAM

REAL-TIME DATA HANDLING

The control logic module contains the range time interrupt logic, the computer switchover logic, the memory lockout logic, and scanner internal function disable logic. These logic units, together with the Master Control Console, provide the real-time automatic system control.

POST-FLIGHT DATA HANDLING

POST-FLIGHT DATA HANDLING

This section is presented in two parts. The first describes procedures and techniques used to prepare data for reduction. The second part describes the data reduction equipment used in these procedures.

The AFETR provides three types of data to Range Users: real-time (see Real-Time Data Handling), quick-look, and postflight. The quick-look, or limited data analysis, is presented as soon as possible (usually within six hours after a test), and the postflight is a final report, including complete data reduction.

QUICK-LOOK

Quick-look trajectory data computations are made either by the Real-Time Computer System at Cape Kennedy or by the Data Reduction Laboratory at Patrick AFB, depending on the type of requirement and the allowable time. A staff of computer analysts and programmers is available for special tasks. Typical quick-look trajectory computations are made using trajectory data and/or MILS data.

Quick-look telemetry data presentations are made with stripout equipment (see Telemetry), in addition to the real-time presentations, by reconnecting the stripout equipment and reproducing the original data from the tape recorder. Computations are not usually made on quick-look telemetry playbacks.

FINAL DATA REDUCTION

Final trajectory data is reduced at Patrick AFB. The techniques and equipment differ for each type of data, with trajectory portions published as specified by the Range User. If requested, a Best Estimate of Trajectory (BET), combining estimates from various tracking instruments, is furnished.

Data from the following instrumentation can be recorded by the Cape Kennedy Real-Time Computer System in transmission modulated form: AN/FPS-16 radar at Cape Kennedy; AN/FPQ-13 radar at GBI; and AN/TPQ-18/FPQ-6 radars at Merritt Island, Patrick AFB, Grand Turk, and Antigua. Before trajectory data reduction can commence, all data must be converted to computer compatible magnetic tape format. For AN/TPQ-18, AN/FPQ-6, AN/FPQ-13, and AN/FPS-16 radars, this process is accomplished by the Data Conversion system at Patrick AFB data reduction headquarters.

Data from the AN/FPS-16 and TTR radars at Ascension is recorded on site and the tapes flown to Patrick AFB for conversion to a digital format and reduction. Quick-look data is transmitted from Ascension to Cape Kennedy AFS Computer Center by HF radio (Kineplex modem).

POST-FLIGHT DATA HANDLING

PROCEDURES

Pulse Radar Reduction

Radar data tapes are converted to a computer compatible format by data conversion equipment. The digital tape for each radar is then input to the computer for editing and standard deviation computations. A tabular copy of the computer processed data containing T, A, E, and R with first and second differences; sigma A, E, and R; and AGC or event data is outputted for analysis by the Data Reduction Unit.

The output data (T, A, E, and R) is corrected for all known errors. The corrections are determined by the Data Reduction Unit and applied by the computer. Typical corrections are zero set, beacon delay, refraction, transit time, station timing delays, and digital errors not previously detected by the computer.

The final output parameters and coordinate systems are optional within the program. A Cartesian coordinate system with unsmoothed position, smoothed velocity, and smoothed acceleration along with random and total error estimates is most frequently requested by the customer.

Telemetry Reduction

Analog tapes from telemetry sites, digitized by the Tare equipment produce a magnetic tape for entry into the computer. The digitized output, along with the specified raw data counts, is fed to the computer. The data is returned, linearized, and checked for errors. A range time to GMT correlation for the period when data was recorded is made.

MILS Reduction

The analog signals from an energy source are received by hydrophones and relayed by cable to a land station. At the land station, the signal is amplified and recorded on magnetic tape and Sanborn graphics. A simultaneous recording is made of an accurate timing standard. The time of signal arrival is precisely determined by visual examination of the Sanborn graphics or use of the MILS Signal Analyzer System. The signal arrival times along with station locations, underwater sound velocities, and various other control data are fed into the computer. The miss distances, confidence figures, and impact location are computed.

Ballistic Camera Reduction

Plate coordinate measurements of star images and data points from two or more cameras are supplied to the computer on cards or magnetic tape (converted from paper tape or cards) with station constant cards. The star images and data points measurements are edited and corrected for calibrated reading equipment errors, lens distortion, and atmospheric refraction. Camera orientations obtained from star images are used to compute unsmoothed Cartesian positions and estimates of error in position

POST-FLIGHT DATA HANDLING

and plate coordinate adjustments. These parameters are edited and prepared for entry into the computer for coordinate transformation and for the Flight Test Report.

Cinetheodolite Reduction

Azimuth and elevation angles from processed film are read on film readers and punched on paper tape or cards which are then converted to magnetic tape in a form compatible with the computer. The magnetic tape, containing data from two or more cameras, is then submitted to the computer for editing and for atmospheric refraction, earth curvature, and known instrument error corrections. The results are unsmoothed position; smoothed velocity and acceleration; estimates of total error in position, velocity, and acceleration, other standard deviations; and other derivative data when required. These parameters are edited for validity and submitted to the computer for incorporation into Flight Test Data for publication.

Attitude Reduction

Apparent pitch angles are measured on film from two to eight tracking cameras and the reading punched on a paper tape. The paper tape is converted to magnetic tape for input to the computer, together with position data and punched cards giving locations of cameras and type of attitude desired. The raw readings are edited, and pitch, yaw, direction cosines, and estimates of error are computed.

For roll data, three distinct points on the missile image circumference are measured by the Gaertner microscope several times for each frame of data. The readings are punched in paper tape; this data is then placed on magnetic tape for input to the computer, together with punched cards giving the missile's spatial position, camera location, and apparent pitch. The Gaertner microscope readings are averaged, edited, and the amount of missile roll between successive frames computed. Total roll is referenced to the first frame read.

Fixed Camera Reduction

Processed film is received from a group of two to 12 cameras around the launch pad. The position of the target board images are read on the Gaertner microscope and combined with survey information and dial readings from the cameras to produce a computed orientation for each camera. The orientation data is then used with edited missile position readings corrected for lens distortion and refraction to produce position data. This unsmoothed position data is used by the computer to derive velocity and acceleration data smoothed over 1 to 2 seconds. The final data is again submitted to the computer for the Flight Test Report.

POST-FLIGHT DATA HANDLING

DATA FORMAT

Flight Test Report

The Flight Test Report is produced from microfilm which is generated on the SC-4020. The data history of a particular mission is reproduced from the film into book form on the Xerox Copyflo. Headings are also printed with the digital data to identify the instrumentation, parameters, missile name and number, liftoff data, etc. All instrumentation used for a particular mission produces a complete digital history of flight and is presented by the Flight Test Report in a specified format.

DATA REDUCTION EQUIPMENT

Data reduction equipment for postlaunch data processing, in the Technical Laboratory, Patrick AFB, is divided into three areas.

- Data Digitizing
- Data Processing
- Data Display

DATA DIGITIZING

Data Converter

The original data converter consists of equipment to convert data recorded in transmission modulated from from AN/FPS-16 radars to computer compatible magnetic tape format.

Digital magnetic tape can be made in real time from one tracking source. The remainder are played back into the appropriate demodulator receiver and the buffering equipment for one-at-a-time preparation of a computer formatted tape.

Data from pulse radars is entered on the digital output tape at four words/record (range, azimuth, elevation, and time).

End-of-record gaps are entered automatically between data records, and for manual entry, by the record pushbutton. After preparing the digital tape for one instrumentation system, an end-of-file record is entered on the tape by pushbutton.

The data converter can also accept FPQ-6, TPQ-18, and Station 12 pulse radar data from a DH-67 RATAAC and Milgo 1623 buffers. These buffers along with an FR-1100 tape unit are located in the Tech Lab.

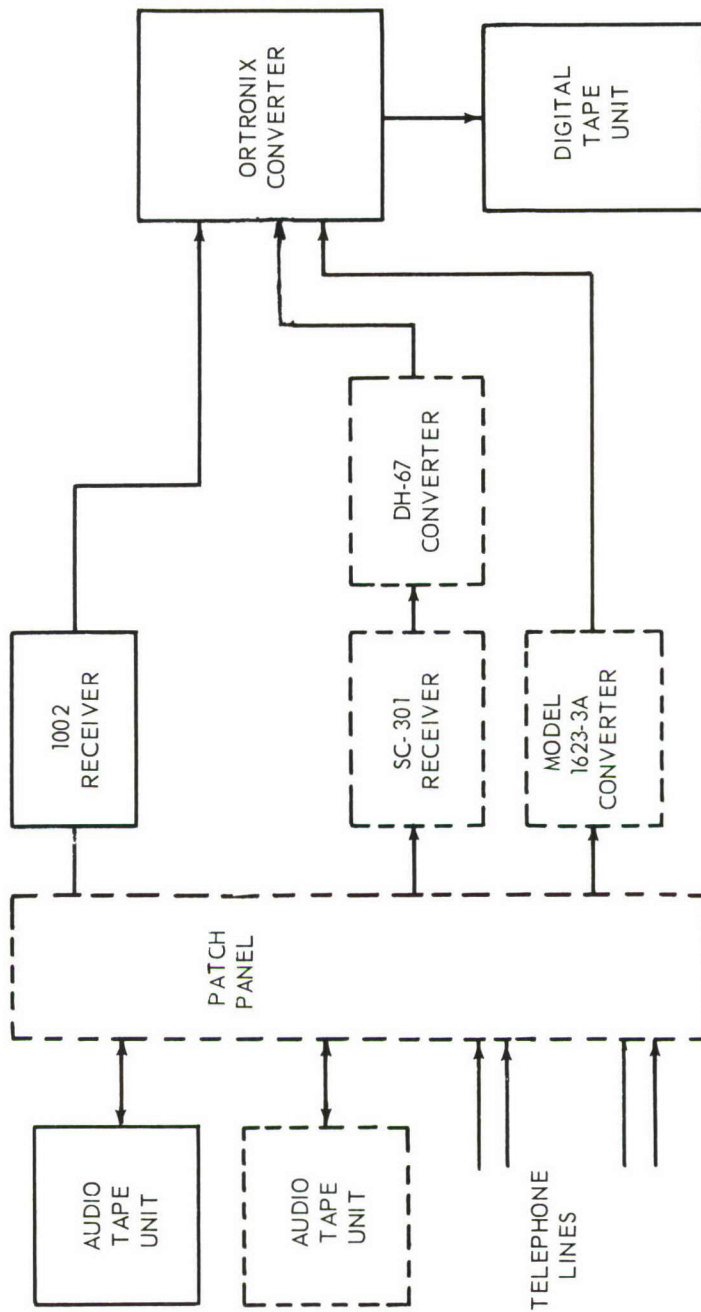

FIGURE 42 EXPANDED DATA REDUCTION CONVERSION EQUIPMENT

RIS Data Playback and Digitizing Equipment (DPDE)

The basic function of this equipment is to provide playback, display, filming, reproduction, reduction, and digitizing of video tapes from the ships.

The equipment consists of a video recorder/reproducer system with remote control and dubbing abilities, a range tracking system, a tape search feature, film editing, an oscilloscope display for visual observation of video data, and a digital data processing system to provide recordings of selected segments of video data on magnetic tape in computer compatible format.

FIS video tapes are played back on the DPDE. The number of samples per frame of tape is selectable in 10 steps between 1 and 102. The sample rate is selectable in seven steps between 5 MHz and 156.25 kHz which provides a sample spacing of 0.2 to 6.4 μ sec. Preselected portions of the data are then digitized and formatted onto a magnetic tape suitable for entry into either the Real Time Computer System or the Tech Lab computer system.

Telemetry and Doppler Automatic Reduction Equipment (Tare)

Tare is a solid state, analog-to-digital converter with multiplexing ability, high sampling rates, and variable output formats for digitizing telemetry, infrared, Doppler, event, Centaur PCM, and signal strength data recorded on magnetic tape in frequency modulated or analog form. It also includes provision to convert paper tape data to magnetic tape data.

Four magnetic tape reproducers are connected to a patch panel. The 1/4-in., two-channel tape handler will accommodate reels up to 10-1/2-in. diameter. The 1/2-in. and 1-in. tape units will take reels up to 14-in. diameter. Tape speeds for all units are 7.5, 15, 30, or 60-in./sec.

FM or FM/FM, PAM/FM, or PDM/FM recordings may be handled in any of the following telemetry subcarriers: 0.4, 0.56, 0.73, 0.96, 1.3, 1.7, 2.3, 3.0, 3.9, 5.4, 7.35, 10.5, or 14.5 kHz at ± 7.5 percent maximum deviation, and 22.0, 40.0, 52.5, or 70.0 kHz at ± 7.5 or ± 15 percent maximum deviation.

PAM/FM recordings require a master constant width pulse at regular intervals. The maximum segment rate does not exceed 3,600 segments/sec, and the number of segments in a frame lies between 1 and 999.

Event times may be singled out if their amplitude is higher than the maximum background noise. The event rate must be less than 3 kHz.

One to 10 channels may be digitized simultaneously for continuous data. The multiplexing rate is 5 kHz, so that the channels are 200 μ sec apart. The sampling rate can be from one to 5,000 samples/sec. Analog quantities are converted into an 11-bit digital number with the least bit equivalent to 10 mv.

POST-FLIGHT DATA HANDLING

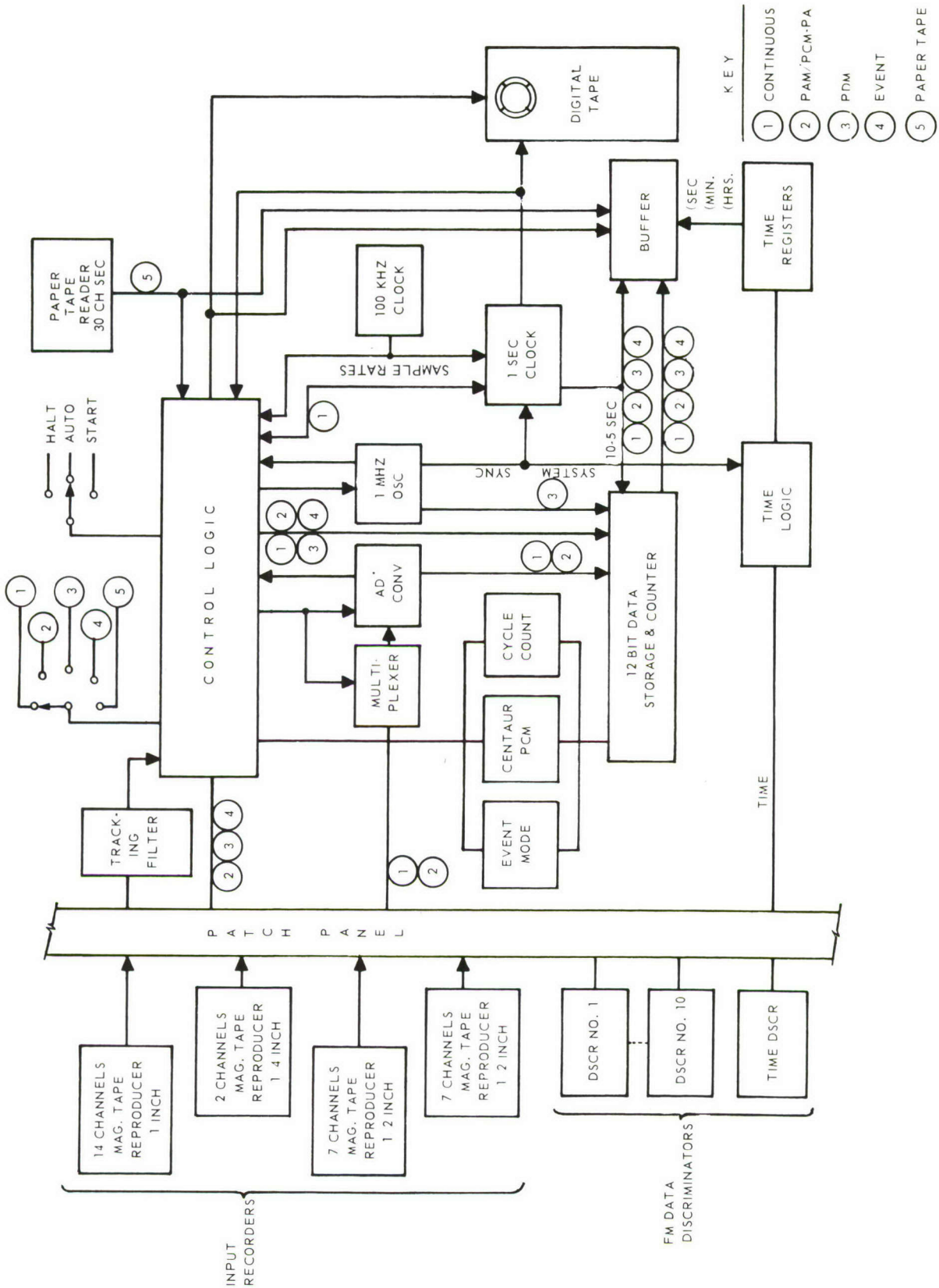

FIGURE 43 TELEMETRY AND DOPPLER AUTOMATIC REDUCTION EQUIPMENT (TARE)

Any number of consecutive segments within a frame of PAM data can be digitized.

PDM data is digitized using a 1-MHz oscillator and a 12-bit counter, with a consequent resolution of 1 μ sec.

Event times may be computed to a resolution of 10 μ sec, and the normal time word resolution is 100 μ sec.

A record of output data on magnetic tape (556 bits/in.) contains a maximum of 182, 36-bit words plus a 36-bit time word.

An ID record may be entered from paper tape and placed in the first record of a file on magnetic tape. The 6-channel paper tape must have a 1/10-in. channel separation, and must be no wider than 7/8-inch. The first character on the tape is recognized as a start code and does not get converted. A Flexowriter stop code signifies the end of the conversion. Each paper tape character is converted into a corresponding magnetic tape character. The conversion speed is limited by a paper tape reader to 30 characters/sec.

In addition to telemetric reduction, some analog data from NASA-operated Udop equipment in the Cape Kennedy area is digitized on Tare at Patrick AFB. This equipment is also used to digitize cyclic telemetry data.

Doppler data from each receiver is recorded on separate tape channels and digitized separately to obtain range sum data.

The tape-recorded 100-pps timed pulses provide a common reference for all frequencies. The timing code is a 17-digit (G-3) or 23-digit (IRIG-B), pulse-width binary code indicating hour, minute, and second. Under present programming a readout rate of 100 is generated.

The data being read is fed (simultaneously with time) through a tracking filter into a cross-over detector. The filter reduces data noise by following the frequency of the doppler signal and removing upper and lower sidebands. The cross-over detects a signal crossing a reference level in the positive-going direction. The positive-going cross-over must follow a negative maximum peak and be followed by a positive maximum peak to be detected. The detector's output has a pulse for every positive-going cross-over, and for every doppler cycle. At 100-pps intervals, the count is sampled and recorded on the output tape without changing the count in the accumulator. Since the readout is initiated by timing signals rather than cross-over pulses, it may occur anywhere in a cycle. This makes it necessary to determine the fraction of a cycle between the last cross-over pulse and the readout pulse in order to obtain a complete cycle count.

The partial cycle between the last cross-over pulse and the readout is determined by counting the number of pulses generated by a 5 MHz oscillator. Since cross-over pulses seldom occur at uniform time levels, the number of such 5 MHz pulses and a complete doppler cycle will vary. It is assumed that any two successive cross-over pulses will not vary more than one or two 5 MHz clock pulses.

POST-FLIGHT DATA HANDLING

Therefore, if the number of pulses in a partial cycle is divided by the number of pulses in the preceding full cycle, the result will approximate the partial cycle, and the number of clock pulses in the last full cycle will also be stored for readout.

AN NRZ synchronizing circuit degitizes NRZ PAM data through Tare. To satisfy certain Centaur requirements, Tare has been modified to translate PCM/PCM-PA data into computer format.

DATA PROCESSING COMPUTER

The data processing function is accomplished by the use of the following systems: two IBM 7094s, and IBM 360/65, and the MILS Signal Analyzer System.

The IBM 7094s and the 360/65 systems reduce the bulk of postlaunch data. Each computer is configured with two data channels providing the capability to perform input, output, and compute operations simultaneously. One of the 7094s has 13 Mod II tape drives and the other has eight. In addition they share five tape drives which are switchable to either system.

The MILS Signal Analyzer is a high speed digital system used to perform detailed analysis and reduction of acoustic signals which have been recorded on magnetic tapes at various MILS stations. The system incorporates a high-speed digital spectrum analyzer with its own 8,196 word memory interfaced with a DDP-116 computer containing another 8,196 word memory, two digital tape units, and teletype units with a paper tape input/output unit. It outputs results on a Cal-Comp X-Y plotter, punched paper tape, magnetic tape, or on a Fairchild scope.

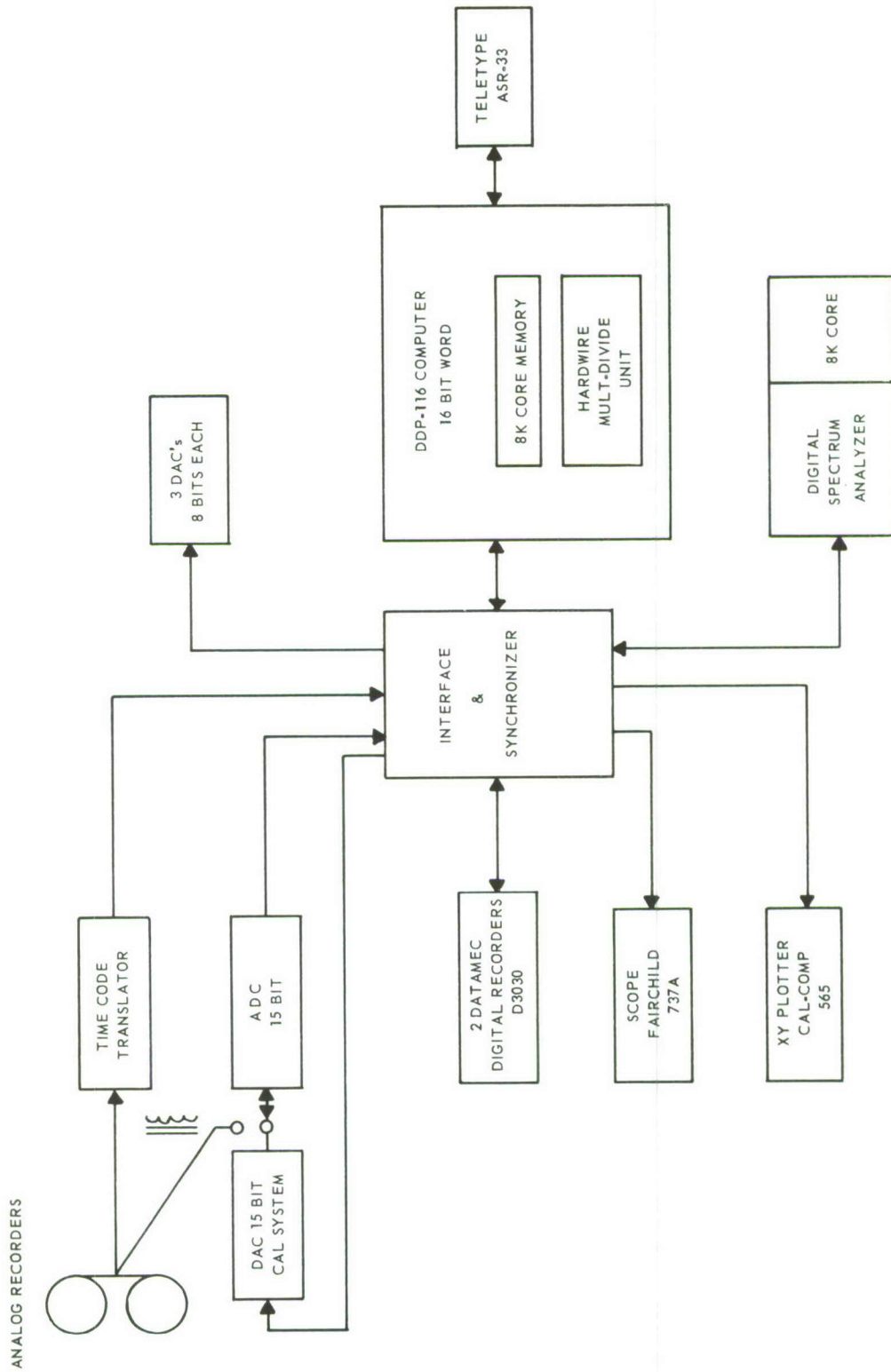

FIGURE 44 MILS SIGNAL ANALYZER SYSTEM

POST-FLIGHT DATA HANDLING

DATA DISPLAY

Four pieces of equipment are used to plot computer-derived data. Two Cal-Comp plotters use paper rolls, one 30-in. wide, the other 10 in. wide. A high speed (SC 4020) plotter produces microfilm which, when developed, may be placed in a Xerox Copyflo II, for conversion of film to paper copy. The Copyflo can reproduce single or continuous sheets of plots or printed matter.

The Cal-Comp digital incremental plotting system is composed of a magnetic tape unit and plotter. The tape format is 200 bpi and 1,002 characters per record in a BCD format. The buffer will drive either the 10 in. (100 steps per inch) or the 30 in. (100 steps per inch) plotter. The 10 in. and 30 in. plotters are accurate to 1/100 of an inch.

The SC 4020 accepts magnetic tape from a digital computer, and records it on 35-mm film in a specified format which may include plotted curves, tabular data, and alphanumeric printing. As the tape is read, desired lines and characters are displayed on a cathode ray tube (CRT). Microfilm is exposed to the CRT, and the results are developed and fed into the Xerox Copyflo for a paper copy, or sent to the user as developed film.

The SC 4020 has a compiler which consists of 30 macroforms designed to facilitate plot production. A symbolic language program fed into a digital computer comprises all macroforms necessary to describe the desired format.

The 4020 can record data on microfilm at 17,400 characters/sec and plot graphs at 12,500 pt/sec.

The deflection conversion circuit allows the beam in the CRT to be deflected to one of 1024 positions in either the horizontal or the vertical direction. Each position may be addressed by a coordinate system of 0 to 1023 raster counts (coordinate positions).

Other machine features include a typewriter model wherein BCD information is displayed in typewriter fashion; bright and faint intensities of exposure are available for character plotting; a vector generator permits drawing a line from a specified point to the resultant of two vector components; an axis generator enables a continuous line to be drawn either vertically or horizontally across the film frame; and a current point register holds the coordinates specified by the previous operation. A modification kit to allow variable intensity of the illuminating beam has been incorporated into the 4020.

The 4020 display is produced as the result of a series of calls to Fortran subroutines. The system provides subprograms that will accept information and perform the necessary scaling and conversion to relate the information to the raster area.

The Xerox Copyflo reproduces copies continuously from 35-mm roll microfilm. The copies are a continuous roll of ordinary paper, vellum, or offset paper masters up to 12-in. wide. Dry copies are made at a rate of 20 linear ft/min.

Plate Previewer

The plate previewer is part of a complete ballistic camera reading system which can be used to read ballistic camera plates.

The viewer console has a measuring table, a 20 or 30 magnification microscope, and an IBM 523 card punch output. The edited plate, containing circled and numbered star images, is secured on a movable platform which rests on an air cushion. The operator views the plate and moves it with a joystick control (high-speed mode to 18 mm/sec) until the particular area of interest (star or vehicle light) is over an illuminated area within the microscope's field of view. The setting on the image is made manually, using the joystick control in a stepping mode (from 0.5 to 5 microns per step). The operator enters an exposure identification into pushbuttons and sets a numerical (1 to 9) indicator of image quality on a dial. By pushbutton action, this information and the XY coordinates of the points are punched into a card. The data format on the cards is determined by the IBM 523 card punch plugboard.

The movable platform is specified to have a straightness of travel of ± 0.3 microns. A Feranti Moire fringe counting method is used to count to 1 micron. A cathode ray tube allows interpolation to 0.1 micron for calibration purposes.

Mann Comparator

This comparator is designed to make high precision distance measurements on photographic film or plates. It gives direct measurement readings of 0.001 mm, in Cartesian coordinates, by moving a plate or film carrying stage above a projector system along ways that have been adjusted and checked to ± 5 sec.

The comparator will measure 265 mm in the X coordinate and 250 mm in the Y coordinate, almost covering the full area of a 9 x 9-in. plate.

The table may be rotated in angle and the rotation read by either of two verniers to 20 sec of arc. The plate is moved under the stationary reticle by two handwheels. For rapid movement, the plate may be disengaged and moved manually.

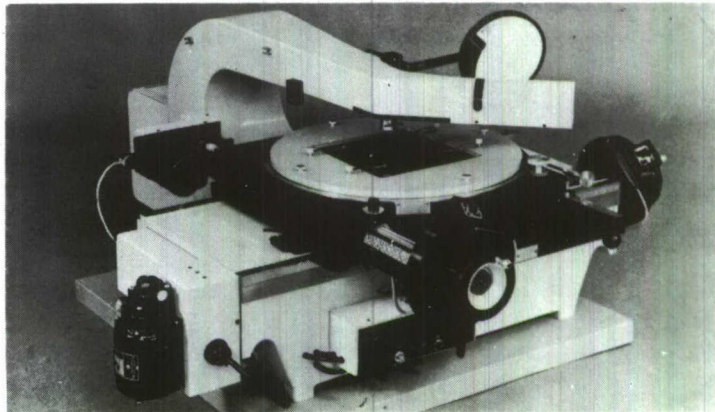

MANN COMPARATOR

POST-FLIGHT DATA HANDLING

The image is magnified by an internally focusing, variable power (10x to 30x) microscope. Four types of reticles are available. The movement of the plate carrying stage is viewed on an illuminated dial. Magnifiers and windows are provided so the operator can read both subintervals and the accumulated turns count. The unit has automatic punched card output.

Mann Digitized Microdensitometer

The digitized microdensitometer is designed to read the dispersed spectral output of tail plumes and reentry bodies as photographed by cinespectrographs.

This equipment includes a precision two coordinate comparator, a sensitive photometer with an output to an analog strip chart recorder, and/or a digitized output direct to a magnetic tape recorder.

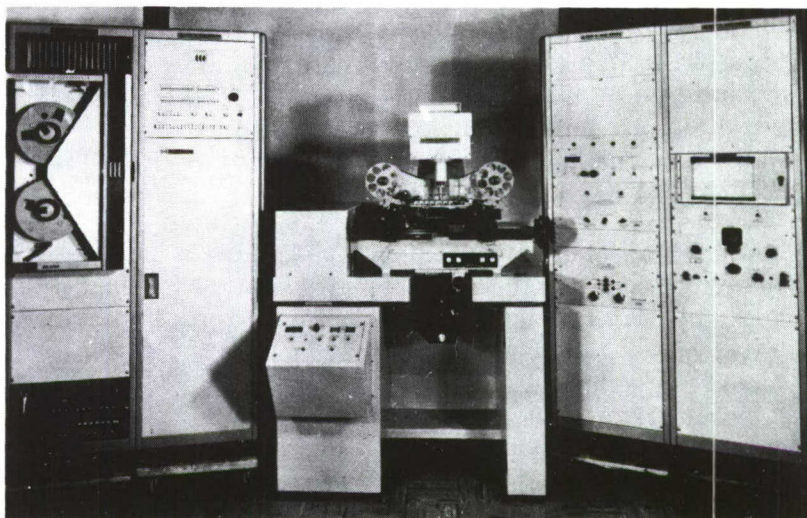

MANN DIGITIZED MICRODENSITOMETER

The microdensitometer has adjustable slit areas to limit the area for density measurements. Slit widths are adjustable from a width of 0 to 3000 microns. Slit heights are adjustable from 0 to 24 mm. A micro-spot which is 2 microns in diameter at the film plane can also be used for density measurements of the smallest areas.

The microdensitometer can be operated to read approximate specular density, over a range of densities from 0 to 5. The digitized rate of reading is limited to 125 mm/min with a sampling down to 1 micron intervals. The analog sampling rate is limited by the speed of the pen response of the chart recorder.

Coleman Comparators

This equipment handles film widths from 16 mm to 5-1/2 in. On CZR film it measures coordinates of image points from which position data may be computed. The image is projected on a screen at magnifications varying from 6 to 19 power. X and Y coordinate lights indicate the relative position of each carriage. The X and Y precision lead screws are read out to a Flexowriter which makes a punched paper tape and typewriter copy. The least count in the readings is 10 microns, with ± 10 microns at any position on both axes.

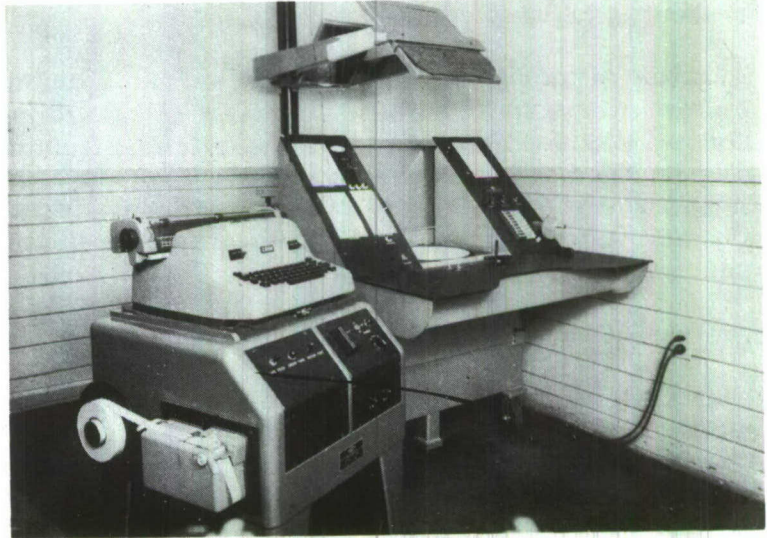

COLEMAN COMPARATOR

Gaertner Microscope, Model 1234

Gaertner microscopes are used to read microscope film. Film moves on the Y axis while the microscope moves on the X axis. Both carriages are manually positioned by precision lead screws. These microscopes, equipped with a graduated dish to read the angular orientation of a missile image, are used to measure target image coordinates and reference points from which camera orientations are computed. They will take film varying from 16 mm through 5-1/2 in.

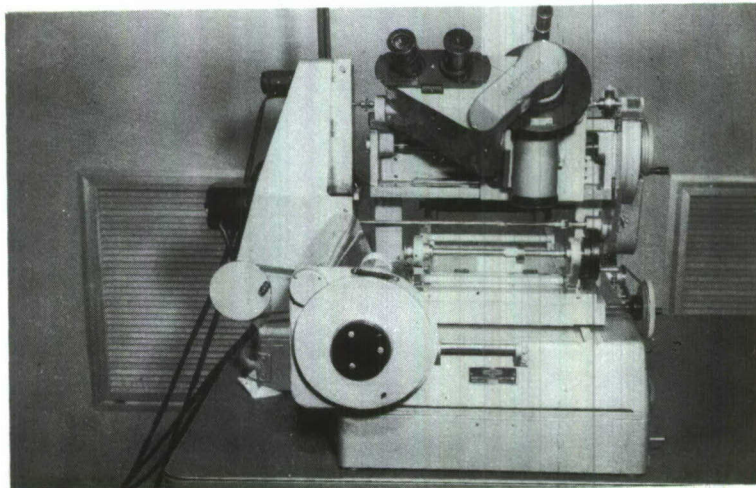

GAERTNER MICROSCOPE, MODEL 1234

POST-FLIGHT DATA HANDLING

The newer instruments have been modified so that data is read out automatically and presented simultaneously on an automatic typewriter and on paper tape. This is done by digitizing the lead screw angles by using a Coleman digitizing kit. One person performs the entire operation, and the equipment is designed so the operator can move the microscope carriage to the next data point while the automatic readout is taking place.

Accuracy of the newer microscopes is from 2 to 5 microns with least count of ± 1 micron over 90 percent of the carriage's transverse range. The lead screws at both ends of the X-range vary by ± 4 microns from a true position. The accuracy of repositioning on a normal image varies from 5 to 14 microns, depending on image quality. The accuracy of repositioning, using a dot source of light as an image, varies between 4 and 7 microns, representing an uncorrected random noise error.

Aeronca Attitude Reader

This device reads attitude data from 35- and 70-mm single frame and 140-mm ribbon frame cameras. It consists of an optical reader, a time constant keyboard, a typewriter with punch, and related electronics. The optical reader views a magnified film image (e. g., a missile). The angular attitude can be read after a vertical line has been positioned to coincide with the image. The time constant keyboard is used to insert time data related to each film frame. The typewriter receives data from the reader and the time constant keyboards, punches it on paper tape in binary coded decimal, and prints a copy.

There are two distinct optical systems in the reader. One aligns the film fiducials, and the other views the missile image and attitude reticle. The fiducial optics incorporate a 10x magnifying system to view two fiducial marks on opposite sides of the film frame.

The attitude optical system is composed of a terrestrial telescope system combined with a periscope arrangement. Two, 2x magnification lenses, mounted 90 deg apart, observe the illuminated reticle and film image simultaneously. These two images are superimposed by a beam splitter and the results passed through magnifying lenses with power of 10x, 15x, 20x, 30x, and 40x when used with the 10x magnification eyepieces.



AERONCA ATTITUDE READER

As the operator rotates the attitude reticle, a 13-bit shaft angle encoder rotates to convert angular information into a form which can be electrically sensed. This information, plus the time values entered in the keyboard, is punched on paper tape and a copy is produced by a typewriter. Data entry into the Flexowriter is automatic. Typewriter codes for tabulation and carriage return are automatically entered between the data entries. The accuracy of the reader is within ± 1 count or $2\text{-}1/6$ min of arc.

Cinetheodolite Reader (for Askania)

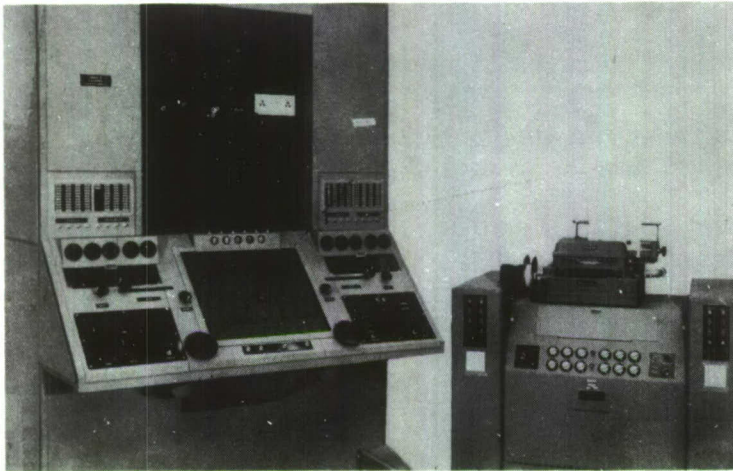

CINETHEODOLITE READER

The Cinetheodolite film reader consists of an optical system which projects an image of the record, magnified 10 times, onto a ground glass screen. The screen is inclined to 28 degrees from the vertical with cross-wires for reading, a bank of decimal counters for recording the position of the cross-hairs, and selector switches for manually recording azimuth and elevation data from each film frame. Associated equipment consists of an

electric typewriter. Indicator lamps with identifying glass overlays indicate the numbers to be entered into the typewriter.

The image position is obtained from horizontal and vertical cross-wires superimposed on the projected film image on the reader screen. The cross-wires are manually positioned so they intersect with the desired point on the image. A counting head, connected to each hand wheel, senses the wheel's rotation and sends impulses to decimal-digit-plus-sign accumulators.

Azimuth and elevation dial images are projected on the main screen. Reading is accomplished by manually reading the dial images to the nearest 0.01 deg.

The whole number of degrees in the azimuth vernier is manually introduced by means of three azimuth dial degree switches with three corresponding elevation dial switches for the elevation vernier reading. Two additional dial switches are used for 0.1 and 0.01 degree setting each for azimuth and elevation. A double frame picture is projected for theodolite film. Film fiducial alignment is performed by four controls on the front panel which permit the image to be horizontally moved $\pm 3/4$ in., vertically moved $\pm 1/2$ in., and rotated by ± 5 deg with magnification adjustment by ± 5 deg.

POST-FLIGHT DATA HANDLING

The film may be advanced in either direction, single frame or continuously, up to 16 fps.

Twelve switches introduce arbitrary constants such as calibration pass or code numbers.

One count of the final output is approximately 0.00035-in. on the film or 0.00083 degree at the usual magnification. The exact calibration of counts to degrees is a function of the focal length. Elevation and azimuth are read to approximately $\pm 1/600$ degree. Two theodolite readers are in operation at Patrick AFB.

High Speed Digital Film Reader for Contraves Cinetheodolites

This film reader is used for the reduction of data gathered with the digitized mobile Contraves theodolite system now incorporated on the ETR.

The new reader is equipped to read out the biquinary digital code presented on the film which includes azimuth and elevation dial readings and digitized frame counter. Tracking error corrections are obtained from the analog to digital converter which is actuated by the operator on the film reader. Output is recorded on punch cards obtained from an IBM 523 Summary Card Punch.

Film reading of up to 35 frames/min is possible with this system. Angular information from the cinetheodolites has an accuracy to ± 4 seconds of arc.

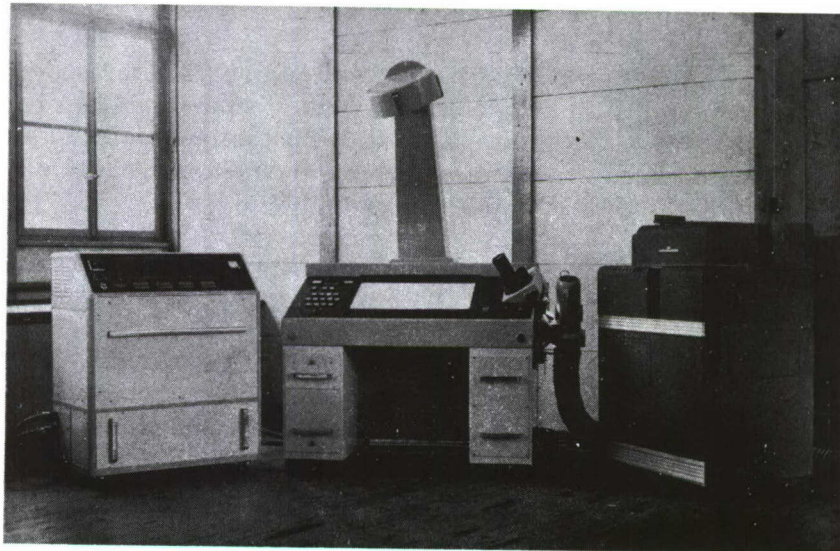

HIGH-SPEED DIGITAL FILM READER

Range Scheduling Equipment

Data transmission equipment for Range Scheduling is installed in the Range Control Center (RCC), CKAFS, and at the Tech Lab, PAFB. The equipment consists of an IBM 1051 control unit, 1052 printer keyboard unit, and a 1056 card reader for each of the two stations. A 1058 printing card punch is installed at the Tech Lab only.

The function of the range scheduling equipment is to transmit the data card image from the RCC to the Tech Lab via the IBM 1050 communications system where the data is processed on the postlaunch data reduction system. After the data has been processed into the range schedule, it is transmitted back to the RCC via the 1050 system for integration into the master plan.

(THIS PAGE LEFT BLANK INTENTIONALLY)

COMMAND CONTROL

DESCRIPTION

The Command/Control System consists of a group of radio transmitting stations used by Range Safety to transmit arm and destruct commands to missiles and spacecraft, and by range users for commands such as abort, engine cutoff, and retrofire.

In operation, the Range Safety Officer (RSO), or the flight controller in the case of range users, initiates a command by closing a switch. The Range Instrumentation Control System (RICS) transmits this closure to all command stations supporting the mission. At each station, the closure is remoted to the transmitter site and activates one of two available coders with the output of the selected coder going to the transmitter. The command is then transmitted from the station which has been preselected. At that station, the output of the coder frequency modulates the carrier and the composite signal is radiated to the vehicle (only one station radiates at a time to avoid mutual interference). At the same time the output of the transmitter is detected before reaching the transmitting antenna and applied to a receiver/decoder, the output of which is recorded on a strip chart and also transmitted back to the RSO (or flight controller) via the remote control group to show the command has been transmitted.

The vehicle receiver receives the RF signal, detects the coded command, and passes it to the decoder. The decoder output is a relay closure which activates the destruct mechanism (or cause some other desired action). Telemetry may or may not report on vehicle response to commands. The RF signal is a frequency modulated carrier in the 406 to 550-MHz band and the carrier deviation is selectable from ± 30 to ± 300 kHz. The modulating signal is supplied by any of three coders.

The ground equipment can be divided into three groups: remoting, coding, and transmitting. Redundancy is used within each group to obtain high reliability. The interconnection of these three groups is always the same although the amount of equipment varies from station to station. A typical downrange system is shown in the block diagram on page 181.

Remoting Group

A means of directly controlling the Command Control encoders and transmitters at Cape Kennedy, GBI, Grand Turk, and Antigua from the Range Control Center at Cape Kennedy is provided by the RICS and local remoting links. The latter consists of FSK tone equipment which transfers closures from the RICS terminals at a given station to the remote transmitter site. Thus, any station can be selected either normally or automatically by a station sequencer. This remoting capability also provides for initiation of Range Safety functions from Cape Kennedy to these downrange stations.

(THIS PAGE LEFT BLANK INTENTIONALLY)

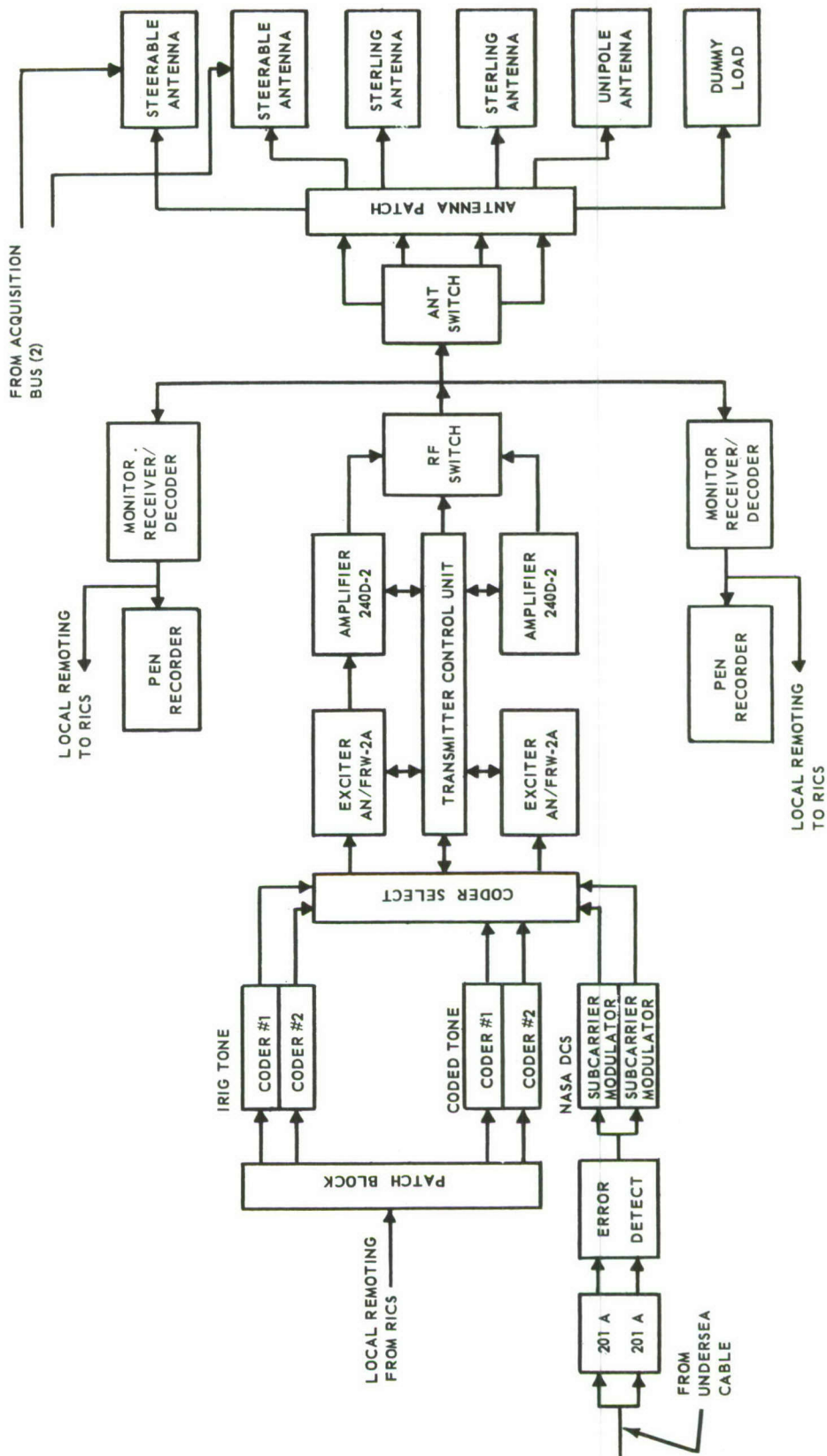

FIGURE 45 TYPICAL COMMAND/CONTROL STATION

COMMAND CONTROL

The data conversion subsystem (see Page 183) sends range user commands from Cape Kennedy to the command/control stations. Basically, the subsystem remotely controls 17 relays by frequency division multiplexing 17 tones onto a 3 kHz circuit. Each tone is frequency shift-keyed (FSK) to open or close the relay contacts. All 17 tone channels are available to Range Users. All receiving equipment is in the command/control buildings at Cape Kennedy, GBI, Grand Turk and Antigua.

Coding Group

The IRIG tone encoder (KY 171/URW) can generate 20 subcarrier channels in the 7.5 to 73.95 kHz band. Up to six tones, generated simultaneously, can be used singly, in combination or in sequence to send a command. The frequency stability of each tone is ± 1 percent. Three channels (1, 2, and 5) are reserved exclusively for Range Safety, leaving 17 to Range Users.

The Digital Range Safety (DRS) System is designed primarily for range safety. Each command word is divided into an 8 bit address followed by three bits to identify the command. The coder can handle six commands for each of two addresses for a total of 12.

Each bit in a command word is transmitted by two tones selected from the seven available in the 7 kHz to 16-kHz band. Each bit in the word may be a different combination of two tones (21 combinations are available). The code used by any particular missile is classified.

Transmitting Group

The AN/FRW-2 FM transmitter, used at most AFETR command stations, is crystal controlled and provides up to 600 watts of RF power. RF power of 10 kilowatts is provided by 240D-2 power amplifiers which are driven by the AN/FRW-2s. At some stations the FRW-2s have been replaced by solid-state exciters having an output up to 100 watts.

Omnidirectional, fixed directional, and slaved steerable antennas are used.

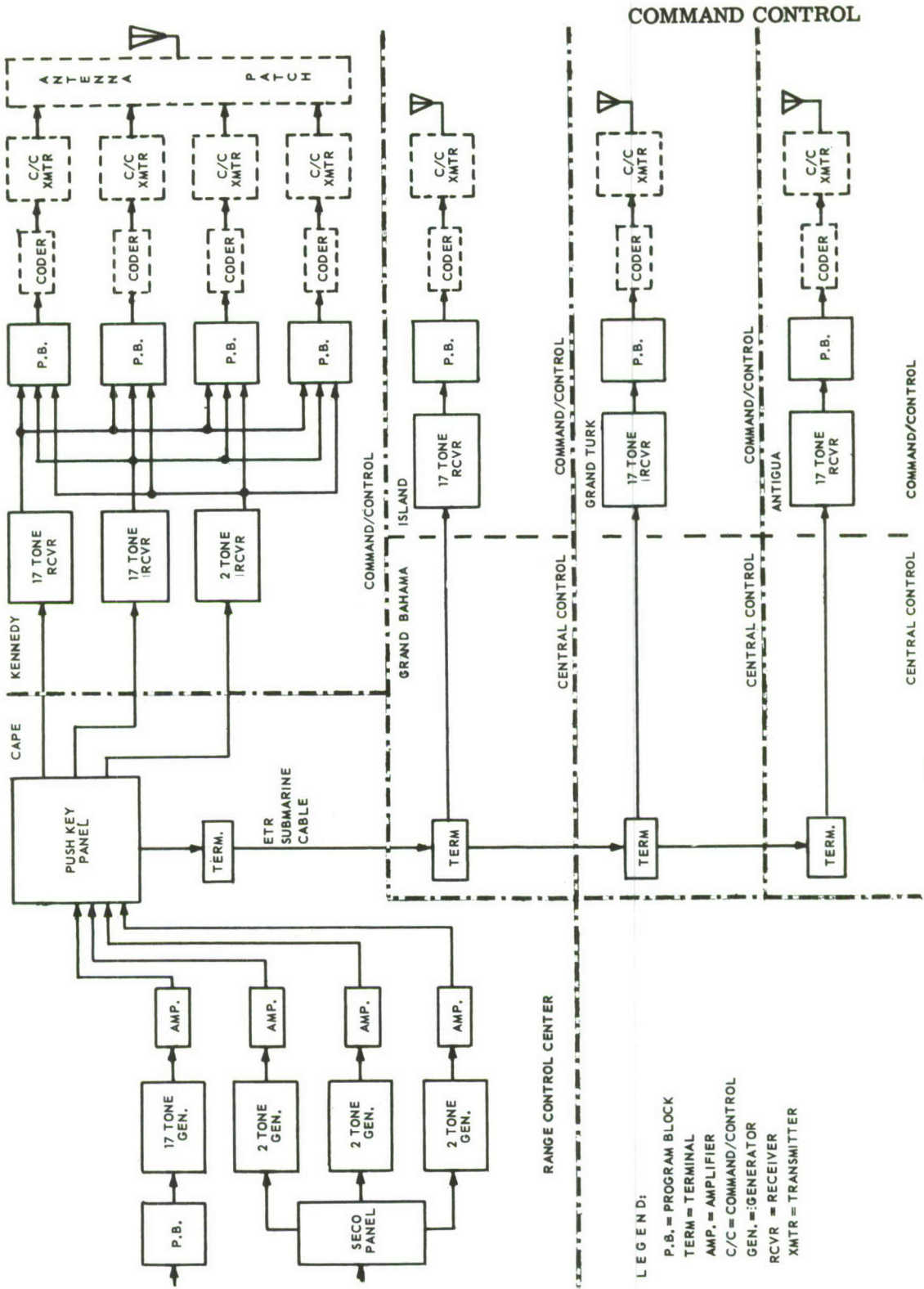

LEGEND:
 P.B. = PROGRAM BLOCK
 TERM = TERMINAL
 AMP. = AMPLIFIER
 C/C = COMMAND/CONTROL
 GEN. = GENERATOR
 RCVR = RECEIVER
 XMTR = TRANSMITTER

FIGURE 46 DATA CONVERSION SUBSYSTEM

COMMAND CONTROL

Locations and capabilities of each command/control station are given on page 184. Each station except Cape Kennedy can radiate on one frequency at a time. The Cape Kennedy station can radiate on up to four different frequencies (one high power for the prime test and three low power for prelaunch checkout).

TECHNICAL CHARACTERISTICS

Antennas

<u>Omnidirectional:</u>	<u>Gabriel</u>	<u>H. P. Circular</u>
Gain	Unity	Unity
Pattern	Toroid	Hemisphere
Polarization	LHC	LHC
Frequency band	400-550 MHz	400-500 MHz
Max. input power	2 kw	10 kw

<u>Fixed Directional:</u>	<u>Helix</u>	<u>Sterling</u>
Gain	10 db	15 db
Beamwidth	45 deg	17 x 55 deg
Frequency band	400-550 MHz	400-550 MHz
Polarization	LHC	LHC
Max. input power	10 kw	10 kw

<u>Steerable:</u>	<u>Esco</u>	<u>Canoga</u>	<u>Aga</u>	<u>(Dish) Temec</u>	<u>Quad Helix Temec</u>
Gain	17 db	18 db	25 db	25 db	18 db
Beamwidth	18 x 30 deg	20 deg	8.5 deg	8.5 deg	20 deg
Freq band	400-500 MHz	406-450 MHz	400-500 MHz	400-500 MHz	400-500 MHz
Polarization	LHC	LHC	LHC	LHC	LHC
Max. input power	15 kw	10 kw	15 kw	15 kw	15 kw

Power Amplifier (240D-2)

Frequency band	400-550 MHz
Bandwidth	3 MHz
Output power	1 - 10 kw
Gain	27 db at 3 MHz bandwidth

Transmitter (AN/FRW-2)

Frequency band	406-549 MHz in 1 MHz steps
Carrier modulation	FM
Carrier deviation	±30 - ±300 kHz
Input voltage	1 v peak-to-peak
Input impedance	560 ohms
Input frequency band	600 Hz - 100 kHz
Max. output power	600 w

RF Exciter (52Q1-TH)

Frequency band	406-500 MHz on 1 MHz steps
Frequency stability	±5 kHz
Carrier modulation	FM
Input level	0 dbm
Input impedance	560 ohms
Input frequency band	300 Hz to 100 kHz
Max. output power	100 w

Description of Commands

IRIG Tone

Tones available	20
Max. simultaneous tones	6
Tone frequencies	7.5 - 73.95 kHz

Range Safety DRS

Tones available	7
Word length	11 bits
Tones per bit	2
Bit rate	116-2/3 bps
Word rate	6 per sec
Tone frequencies	7-16 kHz

COMMAND CONTROL

TABLE 3
COMMAND/CONTROL STATION LOCATIONS AND CAPABILITIES

STATION	MAX. POWER	AVAILABLE CODERS				REMOVING	ANTENNAS
		IRIG TONE	DRS	NASA DCS			
Cape Kennedy -	600 w	X	X		X		
Command Control	10 kw	X	X		X		2 - Canoga (NASA) 1 - Gabriel
							3 - Single Helix (1 - 10 kw, 2 - 600 watt)
							1 - H.P. Circular Omnidirectional
Grand Bahama	10 kw	X			X		2 - Esco 2 - Sterling
Grand Turk	10 kw	X	X		X		1 - Esco 1 - Aga 2 - Sterling
Antigua	10 kw	X	X		X		1 - Temec Dish 1 - Esco

METEOROLOGICAL INSTRUMENTATION

ETR weather stations furnish accurate and timely weather information needed by the ETR and the Range users to schedule tests and analyze missile performance data. The weather stations also participate in hurricane warnings and furnish observations for general distribution.

The routine observational program at all ETR weather stations includes rawinsonde, pilot balloon, and surface observations. Three stations also provide routine rocketsonde observations. Meteorological rocket observations, rawinsonde, wiresonde, and surface observations are also made for Range users and for hurricane warnings on special test support schedules.

ETR weather station observations are transmitted over weather teletype circuits to Cape Kennedy, where they are processed and checked and then used to prepare forecasts. Data is also supplied to Range users and disseminated on national weather circuits.

AN/GMD-2 RAWIN SET

The AN/GMD-2 Rawin Set is a 1680-MHz radio direction finder used exclusively to track a radiosonde or rocketsonde to obtain upper atmospheric parameters. The transmitter generates a crystal-controlled 403 MHz CW carrier amplitude modulated at 81.94 kHz which is called the ranging signal. A transponder radiosonde receives the ranging signal, demodulates it from the 403 MHz, and in turn frequency modulates the 1680 MHz carrier. The 1680 MHz carrier is also pulsed to carry meteorological information supplied by sensors. The antenna system generates an amplitude modulated signal by the conical scan of the reflector. This modulation determines the distance and direction the antenna is off target and returns the antenna to target. The received 1680 MHz signal is amplified, demodulated, and separated; the meteorological information (temperature and humidity or hypsometer) is sent to the AN/TMQ-5C recorder. The range data is compared with the transmitted signal and the information is printed out with angle information, altitude, and time. Altitude is computed by using range and elevation information.

Technical Characteristics

Antenna System

Scan pattern: Conical
Reflector: Parabolic, focal length 28.1 in.
Receiving antenna: Single dipole, 1680 MHz
Transmitting antenna: Band dipole, 400-406 MHz
Tracking modes: Automatic, local manual, or remote manual
Azimuth: Continuous 0.05 deg accuracy
Elevation: -3.0 to +90 deg, 0.05 deg accuracy between +10 and +60 deg

METEOROLOGICAL INSTRUMENTATION

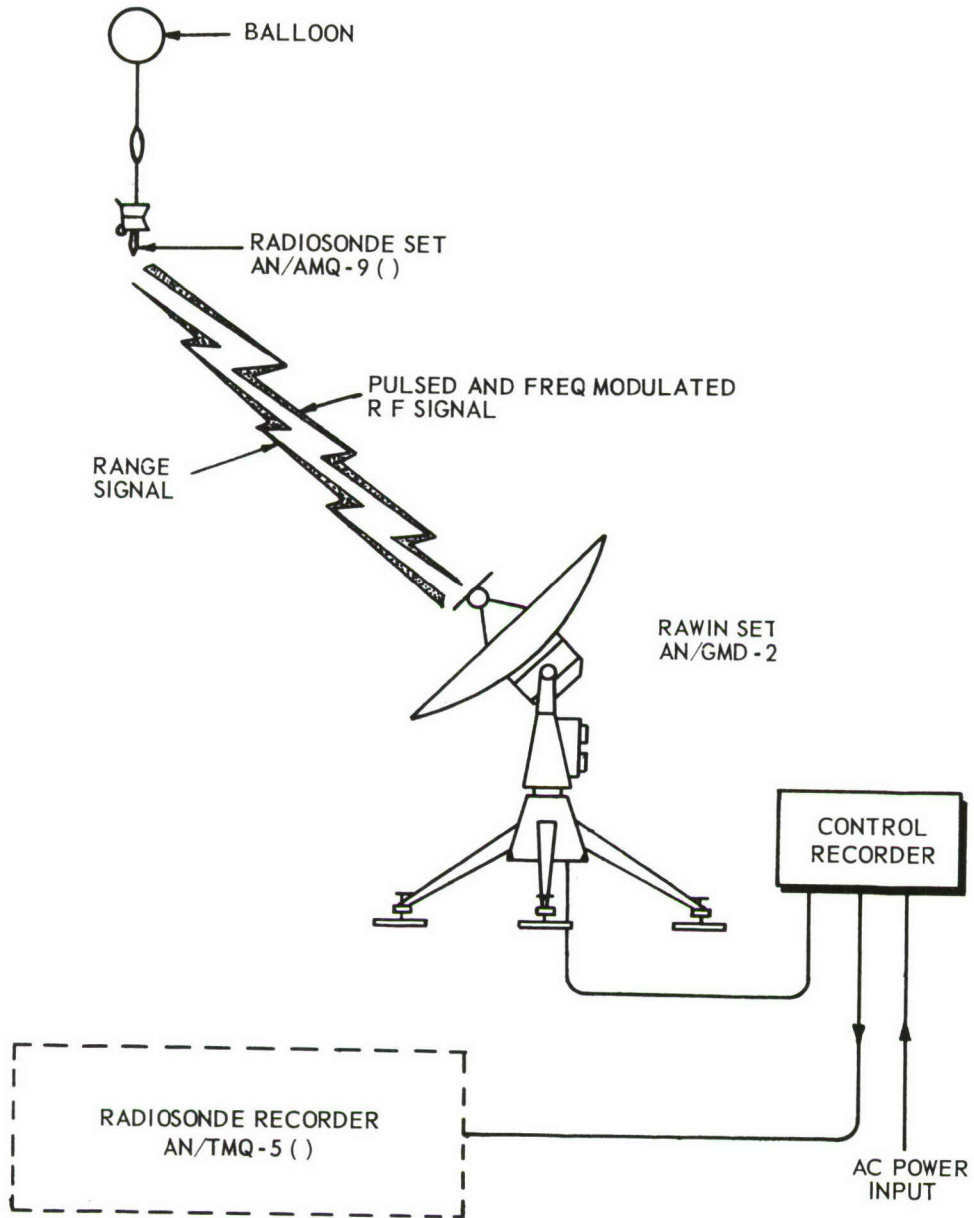

FIGURE 47 AN/GMD-2 RAWINSONDE SYSTEM

Receiving System

Type: Superheterodyne
Normal frequency: 1680 MHz
LO frequency: 1650 MHz
Intermediate frequency: 30 MHz
Frequency control: Automatic or manual
Bandwidth: Sharp, 0.8 MHz; broad, 2.5 MHz

Transmitting System

Frequency range: 400 to 406 MHz (CW)
Modulation: Amplitude, 81.94 kHz
Frequency selection: Crystal switching 400, 401, 402, 403, 404, 405, and 406 MHz

Ranging System

Slant range determination: Phase comparison between transmitted and received 81.94 kHz signals
Range readout: Servo-driven counter, range to nearest 10 yards (0 to 250,000 yards limit)

Recording, Computing and Indicating System

Inputs: Synchro voltages denoting azimuth and elevation angles and slant range
Computation: Altitude (0 to 120,000 ft above sea level)

AN/TMQ-5 () RADIOSONDE RECORDER

The AN/TMQ-5 radiosonde recorder is an electronic meteorological instrument which records weather information that is transmitted by a balloon-borne radiosonde. The meteorological signal is transmitted from the radiosonde in either AM or FM mode in the form of pulses at an audio rate of 10 to 220 pulses per second. The Rawin set receives the signal, demodulates it, separates the meteorological information, amplifies, and converts it to the proper shape.

No special sequence or time is required to record the information since only one bit of information is recorded at any time. The information characteristic and known sequence determine what information is being recorded. A calibration of a high reference makes it possible to adjust the information for accuracy during the run.

METEOROLOGICAL INSTRUMENTATION

Technical Characteristics

Power requirement:	105 to 125 volts 50 to 60 Hz 225 to 275 watts
Input signal:	Negative-going pulse or sawtooth 10 to 220 pulses per second 10 to 100 volts p-p
Reference adjust:	163 to 242 pulses per second
Weight:	490 lb
Dimensions:	33-7/8 in. high, 22-7/8 in. wide, and 17-3/8 in. deep

METEOROLOGICAL DATA PROCESSOR MODEL 3703 ()

The meteorological data processor, when operated with a modified Rawinsonde Set, AN/GMD-2, automatically provides digital data on punched paper tape. This data represents:

- (1) Temperature and humidity circuit frequency data being transmitted from the radiosonde, corrected for reference frequency drift.
- (2) Azimuth and elevation tracking angles, and slant range from the AN/GMD-2 to the balloon or rocket-borne radiosonde set.
- (3) Elapsed time.

Station identification, prelaunch calibration data, etc., may be entered manually. The data, acquired in real time, is presented on teletype-coded, punched paper tape.

When the AN/GMD-2 is modified by installing a data processor, the system becomes the AN/GMD-4. The modification consists of removing the control recorder, replacing the selsyns with optical shaft encoders, and relocating the comparator.

AN/AMQ-9 RADIOSONDE

This balloon-borne transponder type radiosonde, designed for use with the AN/GMD-2 or AN/GMD-4 ground equipment, uses a clock-driven commutator to switch between reference frequency, humidity data, and temperature data.

Technical Characteristics

Transmitter frequency: 1680 MHz nominal
Transmitter power: 300 mw nominal

METEOROLOGICAL INSTRUMENTATION

Modulation: Frequency and pulse modulation

Receiver frequency: 403 MHz nominal

Power supply: Battery BA-380/AM, 115v, 6v, 1.5v

Receiver bandwidth: 60db down at ± 5 MHz from center frequency

WINDSONDE

The windsonde is a balloon-borne, lightweight transponder type instrument designed for making measurements of winds aloft with the AN/GMD-2 or GMD-4 systems.

Technical Characteristics

Transmitter frequency: 1680 MHz nominal

Transmitter power: 300 mw nominal

Modulation: Frequency modulation

Receiver frequency: 403 MHz nominal

Power Supply: Battery Pack BA-259

Weight: 750 grams with battery

AN/AMT-12 RADIOSONDE

The AN/AMT-12 Radiosonde is a balloon-borne, battery powered radiosonde that automatically transmits temperature, humidity, and pressure reference data to the Rawin Set. The AN/AMT-12 is equipped with a hypsometer for accurate determination of pressure above 50 mbs. The AN/AMT-12 consists of modulator, transmitter, and power supply. This type sonde is used with the AN/GMD-2 or 4 in the nontransponding or AN/GMD-1 mode.

Technical Characteristics

Power Supply: 115 v, 6 v, 1.5 vdc BA-259

Output power: 300 mw

Modulation: Amplitude

Transmitter frequency: 1680 MHz

Antenna: Dipole, end fed

Accuracy: Upper air meteorological data accuracies are specified in AFETRP 105-1

AN/FPS-77 RADAR METEOROLOGICAL SET

The AN/FPS-77 Radar, located at CKAFS, provides displays of the horizontal and vertical cross sections of precipitation areas within a 200 mile radius. The following displays are available:

Plan Position Indicator (dark trace storage tube)

Range-height Indicator

Amplitude-range indicator

METEOROLOGICAL INSTRUMENTATION

Technical Characteristics

Frequency: 5450 to 5650 MHz
Peak power: 250 to 350 kw
Pulse width: 2 usec
IF center frequency: 30 MHz
Receiver noise figure: 9.5 db (max)
Antenna: 8 foot parabolic dish
Antenna beam width: 1.6 degrees
Nominal max range: 200 nm
Antenna positioning accuracy: ± 0.5 degrees

AN/GMQ-13A CLOUD HEIGHT SET

The AN/GMQ-13A is a rotating-beam type ceilometer which provides frequent and accurate observations of the height of the lowest cloud layer. This equipment can observe cloud heights during the day as well as night.

The system consists of three major components--a projector, detector, and indicator. Cloud height measurements are made by triangulation. As used at the Cape Kennedy Weather Station (400 ft baseline), the system provides accurate cloud heights below 1,000 ft, and reasonably accurate heights between 1,000 and 2,000 ft.

ML-121 CEILING LIGHT PROJECTOR

The ML-121 projector is used to determine cloud heights up to 10,000 feet at night. The fixed installation consists of a powerful incandescent lamp housed in a weatherproof metal case with a reflector and focusing system. When the vertically concentrated light beam of the projector is focused on the cloud base, an observer with a clinometer stationed at a measured distance (750 to 1,000 ft) from the projector can compute the cloud height from the inclination angle.

AN/GMQ-11 AND AN/GMQ-20 WIND MEASURING SETS

The AN/GMQ-11 and GMQ-20 wind measuring sets are fixed units which are used to visually indicate or record wind speed and direction at complexes, pads, gantries, control tower, and weather stations. They use a synchro system to indicate wind direction, and a tachometer-magnetovoltmeter system to measure wind speed. Wind directions are given in 5 degree increments through 360 degrees and wind speed is measured from 4 to 120 knots in 2-knot increments.

METEOROLOGICAL INSTRUMENTATION

ML-47/247 and 474 THEODOLITE

Theodolites ML-47-247 and 474 are used to follow and measure the movement of pilot balloons. The speed and direction of the wind at various levels can be plotted from the balloon track. The theodolite is similar to the ordinary transit used by civil engineers, but is of the "broken-axis" or "right-angle telescope" type, which makes it adaptable to balloon observation work.

DOUBLE/TRIPLE THEODOLITE SYSTEM

Double or triple theodolite systems are used on the ETR to provide precise wind profiles through shallow levels in support of missile tests. See Double/Triple Theodolite wind accuracy statement in AFETRP 105-1.

ANEROID BAROMETERS ML-120, 331 and 332

ML-120, 331, and 332 are portable, high-accuracy, aneroid barometers used in fixed or mobile stations. They can be handcarried and used when a mercury barometer would be inconvenient or impractical. Inscribed with dual scales graduated in inches and millibars, these barometers are equipped with a concentric mirror ring to remove parallax errors.

ML-3D BAROGRAPH

Barograph ML-3-D is a precision instrument used to measure and record atmospheric pressure. It makes a continuous paper chart record for a 4-day period.

ML-224/24 PSYCHROMETER

This is a dry and wet bulb thermometer (fixed or portable) for measuring temperature and dew point from which temperature and relative humidity data may be derived.

HYGROTHERMOGRAPH

This automatic mechanical device records temperature and humidity on a chart.

ML-512 MERCURIAL BAROMETER

Barometer ML-512 is a Fortin-type (adjustable cistern) mercury barometer and thermometer. It measures atmospheric pressures from 21 to 33 inches of mercury.

METEOROLOGICAL INSTRUMENTATION

AERO-1927 MERCURIAL BAROMETER

This, essentially, is a gimbal-mounted fixed cistern mercurial barometer for use on ships.

ACCURACY OF SURFACE METEOROLOGICAL INSTRUMENTS AT AFETR

Accuracies of surface meteorological instruments used on the AFETR are specified in AFETRP 105-1.

JIMSPHERE OBSERVATIONS

The Jimsphere is a rigid radar reflective balloon, 1 meter in diameter, which is released and tracked by FPS-16 quality radar to obtain detailed profiles of winds aloft. High resolution wind and wind shear are obtained at 25 meters or 100-ft altitude increments from the surface to 60,000 ft. Jimsphere data accuracies are specified in AFETRP 105-1.

ARCAS METEOROLOGICAL ROCKET SYSTEM

This system consists of a closed breach launcher and a high-performance, solid propellant rocket motor which carries payloads of 5 to 20 pounds to altitudes of approximately 40 miles.

ARCASONDE 1A

The Arcasonde 1A is one of the Arcas rocket payloads used on the ETR. The Arcas rocket motor burnout occurs at T+28 sec at approximately 46,700 ft, at which time a 100 sec delay train is ignited. Delay train burnout (and apogee approximately 210,000 ft) at T+128 sec causes the nosecone and motor to separate. The motor then falls free, and the payload descends on a 15-ft diameter parachute. As the Arcasonde payload descends, temperature measurements are transmitted to the Rawin Set at the weather station. The parachute is made of metalized material, permitting radar track for computing wind direction and speed.

AN/DMQ-9

This remitter-type rocketsonde used with the Arcas rocket consists of a

METEOROLOGICAL INSTRUMENTATION

403 MHz receiver and a 1680 MHz transmitter with modulator and blocking oscillator built into the circuits to transmit temperature and range data. The AN/GMD-2 or Rawin Set, the basic ground instrumentation, includes a 403 MHz transmitter, a 1680 MHz receiver, and a phase measuring type signal comparator to acquire ranging data. The AN/DMQ-9 instrument is deployed on a parachute similar to the Arcasonde IA.

LOKI DARTSONE METEOROLOGICAL ROCKET SYSTEM

The Dartsonde is carried aloft by the Loki rocket. After separation from the rocket, it coasts to a 200,000 ft apogee, at which time the instrument is deployed and descends on a parachute. As the Dartsonde descends, temperature measurements are transmitted to a rawin set. The parachute is tracked by radar to determine wind speed and direction. Accuracies of meteorological rocket data are specified in AFETRP 105-1.

DATA PROCESSING

A general purpose digital computer system is used on the AFETR to provide accurate reduction of upper air meteorological data.

Rawinsonde, windsonde, meteorological rocket, and double theodolite data are some of the data reduced by the system. A printed copy and a perforated tape are made of the incoming data. The raw data is then converted to IBM cards by a tape reader/card punch and loaded into the computer. The data is processed to provide tabular printout of altitude, pressure, temperature, and other meteorological parameters. Tabular printouts, as well as card output decks and magnetic tape, are provided to Range Users to evaluate test performance. Accuracies of the computed meteorological parameters from the various observing systems are stated in AFETRP 105-1.

WEATHER INFORMATION NETWORK AND DISPLAY (WIND) SYSTEM

The WIND system at Cape Kennedy is primarily designed to support operations with potential hazards problems arising from accidental spills of large amounts of volatile toxic liquids. Sensors installed on a number of towers at Cape Kennedy and Merritt Island measure wind direction and

METEOROLOGICAL INSTRUMENTATION

speed, air temperature, temperature difference, and dew point temperature. The raw meteorological data is channeled to a Univac 1218 computer and processed. The Univac 1218 computer calculates the vector mean wind, the mean temperature, mean vertical temperature gradient, mean dew point temperature, the standard deviation of wind direction (azimuth) fluctuations, and the distance at which concentrations of 5 ppm and 25 ppm of the contaminant would exist from designated continuous source points. The computed data is printed out on teletype once each 5, 15, or 30 minutes as selected by the meteorologist.

SUPER LOKI DARTSONDE - TRANSPONDER METEOROLOGICAL ROCKET SYSTEM

The transponder instrument is carried aloft by a Super Loki meteorological rocket. The transponder payload consists of a 403 MHz receiver and 1680 MHz transmitters. Following separation from the rocket, the dart coasts to an approximate altitude of 75 kilometers where the instrument is ejected by a pyrotechnic charge. As the payload descends on a 12 foot diameter starute, temperature measurements are transmitted to the GMD rawin set. Ranging information is provided for computation of wind direction and speeds.

VIPER DART METEOROLOGICAL ROCKET SYSTEM

The Viper Dart system consists of a Viper solid propellant motor as the first stage and non-propulsive dart second stage. The dart contains a radar reflectant Robin Sphere, a payload ejection charge and a delay squib. Burnout of the Viper motor occurs at T plus 3.15 sec (approx 8800 ft) at which time the motor and dart separate. After separation the dart coasts to an approximate altitude of 440,000 ft at which point the Robin sphere is ejected from the dart and inflated. The sphere is tracked by radar during its descent to obtain data from which atmospheric density, wind direction and speed can be computed.

AEDAS (ATMOSPHERIC ELECTRICITY DATA ACQUISITION SYSTEM)

The AEDAS provides the weather forecaster with pertinent data concerning the magnitude, polarity and transient characteristics of the atmospheric electricity potential gradient. Data acquired are used in preparing general use forecasts and severe weather warnings concerning thunderstorms in the CKAFS and KSC areas.

METEOROLOGICAL INSTRUMENTATION

The system consists of an array of field mills in various strategic locations in the areas concerned. The field mills measure the magnitude and polarity of the potential gradient. The data are transmitted to the central unit. The central unit samples the sensors, digitizes, formats, and outputs the data on a standard teletype machine.

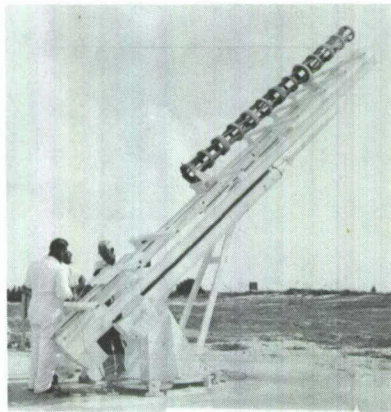

Viper/Dart Weather Rocket

METEOROLOGICAL INSTRUMENTATION

TABLE IV
ETR OBSERVING EQUIPMENT

	Cape Kennedy	Grand Turk	Antigua	Ascension	USNS Redstone	Gen. H. H. Arnold	Gen. Hoyt S. Vandenberg
AN/GMD-2 Rawin Set	1	-	-	-	-	-	-
AN/GMD-4 Rawin Set	2	1	1	1	1	1	1
AN/TMQ-5A Radiosonde Recorder	3	1	1	1	1	1	1
AN/GMQ-13A Cloud Height Set	1	-	-	-	-	-	-
ML-121 Ceiling Light Projector	1	1	1	1	-	-	-
AN/GMQ-11/20 Wind Measuring Set	24	2	2	3	1	1	1
ML-47/247 & 474 Theodolite	5	-	4	4	-	-	-
ML-512 Mercurial Barometer	2	2	2	2	-	-	-
Marine Mercurial Barometer	-	-	-	-	-	1	1
ML-331 Aneroid Barometer	3	-	-	-	2	2	2
PB 210 Aneroid Barometer	2	1	1	1	-	-	-
ARCAS Met Rocket System	1	-	1	1	-	-	-
LOKI Met Rocket System	1	-	-	1	-	-	-
Met Data Processing System	1	-	-	-	-	-	-
Atmospheric Elec Data Acq-Syst.	1	-	-	-	-	-	-
Jimsphere System	1	-	-	-	-	-	-
Closed Circuit TV	1	-	-	-	-	-	-
AN/FPS-77 Radar Meteorological Set	1	-	-	-	-	-	-
Viper Dart Robin Met Rocket Syst.	1	-	-	1	-	-	-
Super Loki Transponder Met Rocket-1	1	-	-	-	-	-	-

RANGE PHOTOGRAPHY

RANGE PHOTOGRAPHY

Range Photography furnishes field photographic services and motion picture and still photo processing for Range Users and other agencies. The Motion Picture Section operates on a production line basis, but maintains a limited job shop ability for expediting Range User selected items (24 hr delivery). All other motion picture jobs are processed on a first in, first out basis and are normally delivered in three to five working days. The Still Photo Section operates as a job shop with rush service for material requested within 24 hours. Other still photography is usually furnished within five working days.

METRIC PHOTOGRAPHY

Metric photography records trajectory data on motion picture films, ballistic camera plates, and wide roll films in color or black and white. This data is acquired by such optical instruments as cinetheodolites, fixed metric cameras, tracking telescopes, and ballistic cameras.

ENGINEERING SEQUENTIAL PHOTOGRAPHY

Engineering sequential photography records events with a time correlation to produce data for Range User analysis. Typical equipment consists of slow, medium, and high speed pad cameras that record release mechanism, umbilical cable, hold down arm, and flame study data at liftoff. Tracking instruments outside the pad area have cameras that record events from liftoff to the limits of visibility. Data read from metric and engineering films is entered into electronic computers to determine trajectory, roll, pitch, and yaw. The results are then reduced to report form. Films are also forwarded to the Range User who prepares data reports describing phenomena observed.

DOCUMENTARY PHOTOGRAPHY

A wide variety of fixed and tracking motion picture and still cameras is used for documentary coverage. These cameras record prelaunch, launch, inflight, and postlaunch events. They also record construction progress at the launch complex, assembly hangars, and at other locations.

PAD COVERAGE PHOTOGRAPHY

The fixed motion picture cameras at the launch pads use film varying in size from 16 to 17 mm, and in frame rates from 2 to more than 1,000 fps. They are located near and around the launcher on the umbilical and service towers, on the blockhouse, and on the perimeter road. They record such engineering sequential and documentary events as ignition, release action, umbilical disconnect, and general surveillance at liftoff. Still sequence cameras are located in the pad area to make documentary photographs of the entire missile during liftoff.

RANGE PHOTOGRAPHY

MOTION PICTURE PROCESSING LABORATORY

Motion picture equipment is classified according to use. Processing equipment develops exposed film to produce a readable image. Printers duplicate these images on film which is then developed to obtain the type of copy desired.

PROCESSING EQUIPMENT

Seven machines furnish immediate processing of a wide variety of films used to gather data during a missile test. All three color film processing machines and two of the black and white machines use the immersion processing method.

Color Processing Equipment

All color processing is done in these immersion type processing units. Processing speeds depend on the type of film and can vary from 20 to 75 fpm. Length of the thread-through film leader ranges from 1,300 feet for the 70 mm color processor to 3,900 feet for the 16 mm Eastman Commercial Ektachrome processor.

Two machines, one 16/35 mm and one 70 mm process Eastman Color reversal films, types ER/EF/MS and Print Stocks. One 16 mm machine processes Eastman Commercial Ektachrome.

Black and White Processing Equipment

Two black and white immersion processors are used with 70 - 80 deg F chemical solutions. This equipment processes 16-, 35- and 70 mm negative or positive film.

Film transport speeds of the black and white machines depend on the type of film and vary from 15 to 50 fpm. Two Viscomat processors are used to process film up to 11 inches wide.

RANGE PHOTOGRAPHY

PRINTING EQUIPMENT

Printing service is provided for 16/35- or 70-mm contact prints and 16/35-mm optical prints. Reduction prints from 35- or 70-mm film are also available.

Contact Printers

Contact equipment prints from one film to another with both films being the same size.



IMMERSION PROCESSOR

Contact printers, used for either black-and-white or color film, print 16-, 35-, or 70-mm, and operate up to 180 fpm. Within limits, correction of color balance or exposure from scene to scene is possible. The film to be duplicated is previewed by eye for timing and color balance. A beam of white light is divided into three primary color beams by dichroic mirrors. Each beam's intensity is individually controlled by positioning vanes. When printing the film, the three beams of light are recombined in a method known as additive printing. As the film moves through the printer, a previously prepared paper tape controls the intensity and color balance of the three beams needed for each scene.

Optical Printers

The optical printers, used for either black and white or color film, record the film image on the same or different size film, as well as produce the image orientation needed for certain types of duplicates. One optical reduction printer, with scene-to-scene additive color control, will reduce from 35- to 16-mm at 15 fpm. One 16 to 16-mm printer with additive color control is used for image positioning and operates at 180 fpm. One printer is used to enlarge prints from 16- to 35-mm, to make reductions from 35- to 16-mm, or as a one-to-one printer. Repetitive printing of selected frames of the original may be made to slow down motion. This printer also has scene-to-scene control and speeds variable up to 8 fpm. One optical printer is available to reduce 70 to 35- or 16-mm film. An ultrasonic film cleaner is used between printing operations.

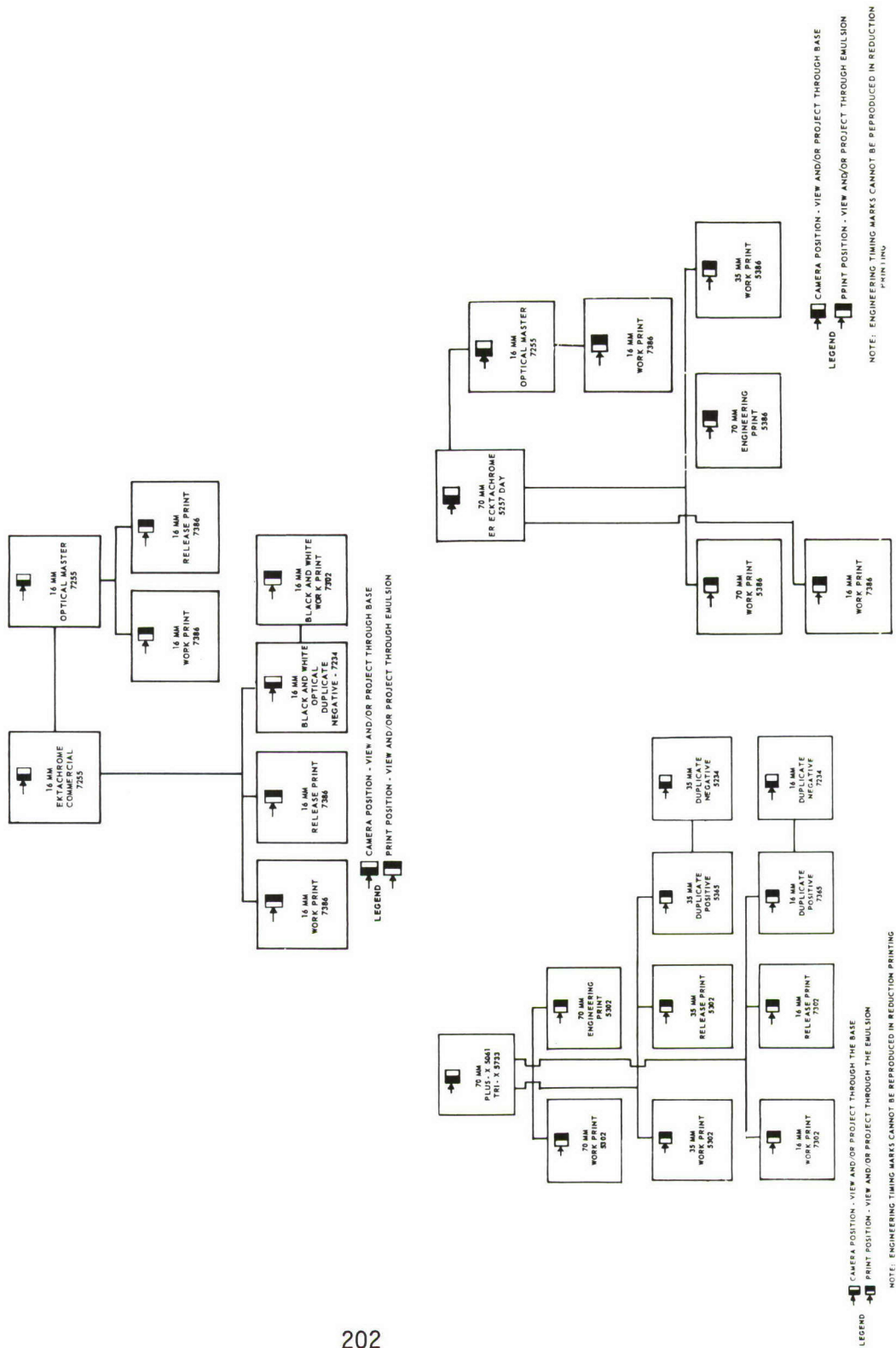

FIGURE 48 STANDARD MOTION PICTURE PRODUCTS

RANGE PHOTOGRAPHY

STILL PHOTOGRAPHY PROCESSING AND PRINTING

A variety of equipment is used for processing black and white and negative color still photographs, including originals, prints, and intermediate duplicates. Film developing includes roll film, film pack, sheet film, glass plates, paper, and telemetry oscillograph records. The printing equipment includes 4 x 5 in. and 10 x 10 in. enlargers with roll easels, 10 x 10 in. and 20 x 30 in. contact printers, a 35 mm optical transparency printer, a vertical reduction printer 4 x 5 in. to 35 mm, dryers, one continuous processor for developing 8 x 10 in. glossy photographic paper prints and one for oscillographic (telemetry) paper, a continuous copy camera for copying oscillograph paper, and copy cameras for 35 mm negatives up to 30 x 40 in. Two black and white continuous film processors are used to process 4 x 5 in. through 8 x 10 in. cut sheet film and roll film in widths from 16 mm through 9 1/2 in. A Kodalith, similar to the Versamat, is used to process the graphic art films. An automatic processor is used for Ektacolor prints up to 30 x 40 in.

IV
RANGE SAFETY

RANGE SAFETY

DESCRIPTION

The ETR Range Safety System provides missile position information from launch through burnout or attainment of orbit. This tracking information is visually compared to the nominal missile trajectory submitted by the range user. Missile subsystem malfunction during flight may result in deviations from the predicted flight path. If the deviation exceeds previously determined criteria, the Range Safety Officer (RSO) will issue a flight termination command.

All safety information is channeled to one or both of two Range Missile Control areas in the Range Control Center. The two areas are functionally similar. One area will always be designated as the primary area and the primary RSO responsible for the launch will be at this console. These areas contain the instrumentation necessary to display missile behavior during all phases of flight. RSOs decide, by use of plotting boards, visual displays, reports of assistants, etc., whether or not a missile's flight should be terminated.

RSO CONSOLES

The RSO consoles have the following equipment:

Communications

Each console consists of dual parallel audio communications panels, consisting of

RANGE SAFETY

20 direct line and 10 network circuits. Each panel contains a master module which provides isolation or group access of the active communications systems and facilitates use of handset, headset, loud speaker, and administration phone.

Command Control Panel

On-off switches and indicators are provided for the primary and emergency Cape command/control transmitters. Lights indicate transmitter failure and automatic switchover to the standby transmitters.

The arm/fuel cutoff and destruct switches are recessed and protected by hinged metal cover. Red light indicators illuminate flashing (arm) or steady (destruct) when the command functions are sent.

A special functions switch provides required selected control signals through the command transmitters.

RICS Panel

Except for the emergency system, this panel contains on-off controls and indicators for all command/control transmitters. Green ready lights show when the transmitters are controlled by the Range Instrumentation Control System and a white light indicates which transmitter is active. Normally the transmitters are turned on and **off** at programmed times by a timer started by the first motion indicator.

Timing and Firing Control Panel

The timing functions include a visual display of automatic (manual back up) first motion elapsed time, Range countdown/plus count, a manual interval timer, and a timer activated by first motion indicating when flight termination action was sent.

A red hold-fire pushbutton switch/indicator provides the RSO with hold-fire capability.

A green proceed indicator illuminates when a hold is not in effect.

COMMAND/CONTROL

The command/control system provides the means for the RSO to terminate missile flight. When tracking information is received indicating that further missile flight should not be permitted, the RSO closes a switch on his console. This closure is sensed by the Range Instrumentation Control System and relayed to each command/control station. At a preselected station, a signal which performs the required function is then transmitted to the vehicle.

RANGE SAFETY

VERTICAL WIRE SKYSCREEN (VWS)

This equipment consists of two vertical parallel wires, 12 in. apart, held in a 12 by 60 in. adjustable frame. The wires are optically aligned (to avoid parallax) from a selected site pedestal through the launch pad/silo. The VWS site for each test is selected as close as possible to a point perpendicular to the flight azimuth and approximately 1 mile from the launch pad. The operator sights along the plane of the wires and gives a verbal account to the primary RSO of the vehicle's behavior throughout its vertical flight.

CLOSED CIRCUIT TELEVISION

Two 17-in. and two 8-in. TV monitors are located in each of the two Range Missile Control display areas in the Range Control Center.

The two 8-in. monitors are located in the RSO console and have a 10 channel selected capability.

The two 17-in. monitors are located above the plotting boards and display program and flightline views of the missile. One van-mounted camera is positioned perpendicular to the expected flight line and another is positioned behind the missile.



VERTICAL WIRE SKYSCREEN
206

RANGE SAFETY

Each Range Safety TV van transmits the TV picture to the TV Operations Control Center via microwave transmitters. The picture is then relayed by hardwire to the Range Safety monitors in the Range Control Center.

PLOTTING BOARDS

Missile tracking data is displayed on six 30 by 30-in., two dimensional plotting boards located in front of the RSO console in each of the two Range Missile Control areas in the Range Control Center. Each board has two plotting pens plus two timing pens so that two different track loci can be displayed simultaneously. The plotting boards are numbered 1 through 6 in Range Missile Control area 1 and 7 through 12 in area 2.

A tracking source indicator located above each plot board indicates both the tracking source and the type track (beacon or skin) being plotted by that board.

Tracking data is presented on the plotting boards as missile present position and vacuum impact prediction displays. Methods for selecting and presenting this data is discussed in the Real Time Data Handling section of this handbook.

RANGE SURVEILLANCE

The positions of ships and aircraft in the launch area are plotted by a Surveillance Control Officer (SCO). This information is gathered by radar and from ETR surveillance helicopters.

A television camera located above the surveillance plot board enables the RSO, via TV monitor, to evaluate the positions of ships and aircraft in or near the danger zones.

PRESENT POSITION DISPLAYS

During flight, vehicle present-position information is displayed to the safety officers on a number of 30 by 30-in., vertical, two dimensional plotting boards. Each board has two plotting pens plus two timing pens, so that two curves may be drawn and displayed simultaneously on each board. (Methods for selecting the data for display are discussed in the Data Handling section.)

The choice of X, Y, and Z coordinates for the X-Z, Y-Z display is made by drawing two impact limit lines across the launch area. The X and Y axes are drawn perpendicular to these two lines (so that X and Y are not mutually perpendicular).

The scales to which the plots are drawn are chosen before the test so a continuous presentation is made, i. e., as time progresses, successively smaller scales are used.

Destruct contours are predrawn from a consideration of the vehicles' expected trajectory; vehicles characteristics such as maximum turning angle, explosion velocity, cross-section area, and drag effects; system delay times (including that of the RSO); expected wind effects; and location of pad and areas to be protected.

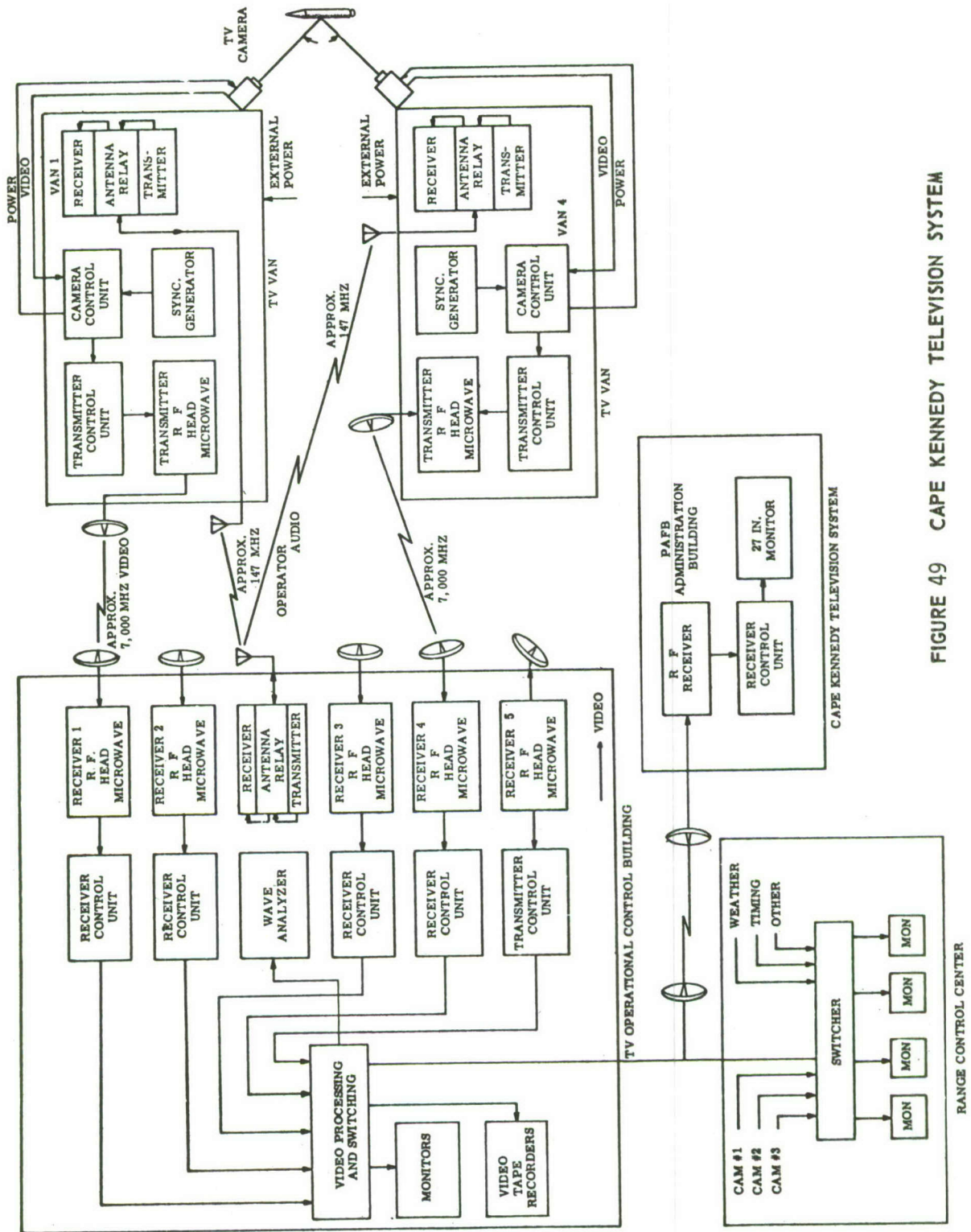

FIGURE 49 CAPE KENNEDY TELEVISION SYSTEM

RANGE SAFETY

The contours are drawn in such a way that when the trajectory becomes parallel to a destruct contour, an unsafe condition exists.

The XY contours are drawn by assuming that at a point in space (corresponding to a point on the XY plane) the vehicle has a velocity component in the XY plane equal to the nominal velocity in that plane. At that point, a horizontal angle exists which, if assumed by the vehicle for a time equal to the system delay time, will allow it to cross the limit line. An angle greater than this will be unsafe. These angles are plotted at various ground ranges as short-line segments connected to form smooth curves. Since these are maximum angle contours, the criteria for unsafe condition becomes one of parallelism between the pen movement and the contours.

For the XY and YZ destruct contours, two impact limit lines are used. Perpendicular lines from the X and Y axes. The vehicle is assumed to lie in the XY (YZ) plane. At a point in that plane an inclination angle exists which, if exceeded by the vehicle, will allow the pieces of the vehicle (if destructed) to impact on the limit line if it flies at maximum turn rate for the system delay time. Effects of wind, drag, and explosion velocities are included. Curves are drawn by connecting short line segments drawn at these angles. The criteria for these is parallelism between the pen movement and the contours.

RANGE SAFETY IMPACT DISPLAY SYSTEMS

These display systems are a high speed direct computer-driven (by the Cape Kennedy RTCS) digital displays. By using computer programs, the displayed information may be changed instantly to provide versatility in mission criteria. Although the equipment is used primarily for displaying impact prediction plots, it is also programmed to display areas, lines, and alpha-numeric information. The display system in the RTCS provides two independent video output channels to the RSO for the Launch Area Recovery System (LARS) and the Range Safety Display System (RSDS). Remoting capabilities are also provided to allow other authorized persons to observe the presentations.

The presentations contain both static and dynamic data and may be stored in a magnetic core memory. Any of the stored presentations may be independently selected for viewing on standard TV monitors in either, or both, areas of the LARS or RSDS Control Display Consoles in the RCC.

RANGE SAFETY

Memory addressing is on a priority basis which allows input/output and display operations to time-share memory. Thus, input/output operations for inserting new information are possible while in a display sequence without a perceptible change in the display information.

Digital-to-video conversion is accomplished in the RTCS by using standard resolution vidicon cameras to scan and monitor computer generated data that is presented on two 5-in. recording CRTs. Video transmission equipment is used to send the TV signals to 14-in. and 17-in. TV monitors located in each Control Console area. A 9-in. standard TV monitor in each section is used for viewing weather mission data.

LARS and RSDS operations consoles are located in the RTCS for maintenance purposes. These consoles provide 17-in. monitors for LARS and RSDS, a 17-in. TV monitor for the RCC, and a sidplay panel for control of the display equipment within the RTCS.

REAL-TIME IMPACT PREDICTION SYSTEM

Present position and impact point data are computed in the Real Time Computer System (RTCS), using two computers which, by means of redundant equipment, can provide protection against component or module failure.

Pulse and radar tracking data and telemetered guidance information are received by the RTCS. The FPQ-6 and TPQ-18 radars use a vestigial sideband serial data system with a bit rate of 2,900 bits/sec. Radar 1.16 uses a tone burst data system with a bit rate of 1,000 bits/sec.

Radar data is recorded on analog tape. This data can be used at a later time to simulate the mission for program and hardware checkout.

All inputs are edited and smoothed. The best data source is selected and used to predict present position and primary impact point. The second best source is used to compute an alternate impact point.

Primary and alternate impact points and present position information are sent to the Range Control Center for presentation to the RSO. The same information is also plotted at the Computer Center.

V

SHIPS AND AIRCRAFT

SHIPS

The AFETR operates one Range Instrumentation Ship (RIS) and two Advanced Range Instrumentation Ships (ARIS) to provide data coverage in areas outside the limits of presently available land stations.

The fleet consists of two C4-S-A1's (ARIS) and one T2-SE-A2 (RIS) class vessels converted to instrumentation ship configuration.

The ships' primary marine characteristics are as follows:

<u>Specification</u>	<u>C4-S-A1 (T-AGM-9 & 10)</u>	<u>T2-SE-A2 (Jumbo) (T-AGM-20)</u>
LOA	522'	595'-5"
Breadth, Molded	72'	75'
Draft	25'	25'
Displacement, Load (tons)	17,120	19,770
Cruising speed (knots)	14	14
Fuel capacity (tons)	2,687	3,724
Cruise range (nm)	13,000	20,150

All ships are identified by number, registered name, and voice call signs, which are tabulated below:

<u>Number</u>	<u>Registered Name</u>	<u>Voice Call Sign</u>
T-AGM-9	Gen. H. H. Arnold	MASTODON
T-AGM-10	Gen. Hoyt S. Vandenberg	PICOPAY
T-AGM-20	Redstone	DISHPAN

C4-S-A1 SHIPS

USNS GEN. H. H. ARNOLD, T-AGM-9, AND
USNS GEN. HOYT S. VANDENBERG, T-AGM-10

The USNS Gen. H. H. Arnold and the USNS Gen. Hoyt S. Vandenberg are converted C-4 cargo class ships. They were formerly used as troopships, but have been converted to Advanced Range Instrumentation Ships (ARIS) for use on the Eastern Test Range. Both ships are equipped with an integrated tracking and data recording instrumentation complex. They have similar instrumentation and data capability, providing digital and analog inertially-referenced trajectory data, multiple frequency radar cross-section data on multiple targets, complete telemetry data on all major links, optical data, meteorological data, and miscellaneous film and chart data.

The instrumentation system is an integrated complex of subsystems primarily designed to record radar signature and metric, optical/opto-radiometric, meteorological and telemetry data associated with the mid-course and reentry phases of ballistic missile flights. The telemetry system can track independently or be slaved to the radar tracker. The tracking radars can track one primary target at C-band and one target at L-band during mission time. Secondary targets may be tracked from the video tape by post-mission processing. All secondary targets are tracked with reference to the primary target. Amplitude cross-section data is available on all secondary targets observed by the radar. In addition to the primary purpose of ARIS as a data-gathering complex for ballistic reentry missions, the ships serve to support metric and telemetry requirements on **other** missile and space vehicle tests.

Data is recorded on digital magnetic tapes, video recorders, video film, plotters and charts. Trajectory data is referenced to a ship's inertial navigation system (SINS). By instrumenting the ships with navigation, communication, timing and data handling equipment, each ship can operate, fully independent, in remote areas, acquiring and storing large quantities of radar, telemetry, optical, meteorological, calibration and reference data for later processing and evaluation.

The instrumentation system is composed of 10 major subsystems, briefly described as follows:

Operations Control Center (OCC)

The OCC is a central control facility providing integrated operations both aboard ship and between the ship and other stations. Three major equipment items in this area are the Master Control Console (MCC), the Designate Control Console (DCC), and the Target Trajectory Plotter (TTP).

ARIS INBOARD PROFILE

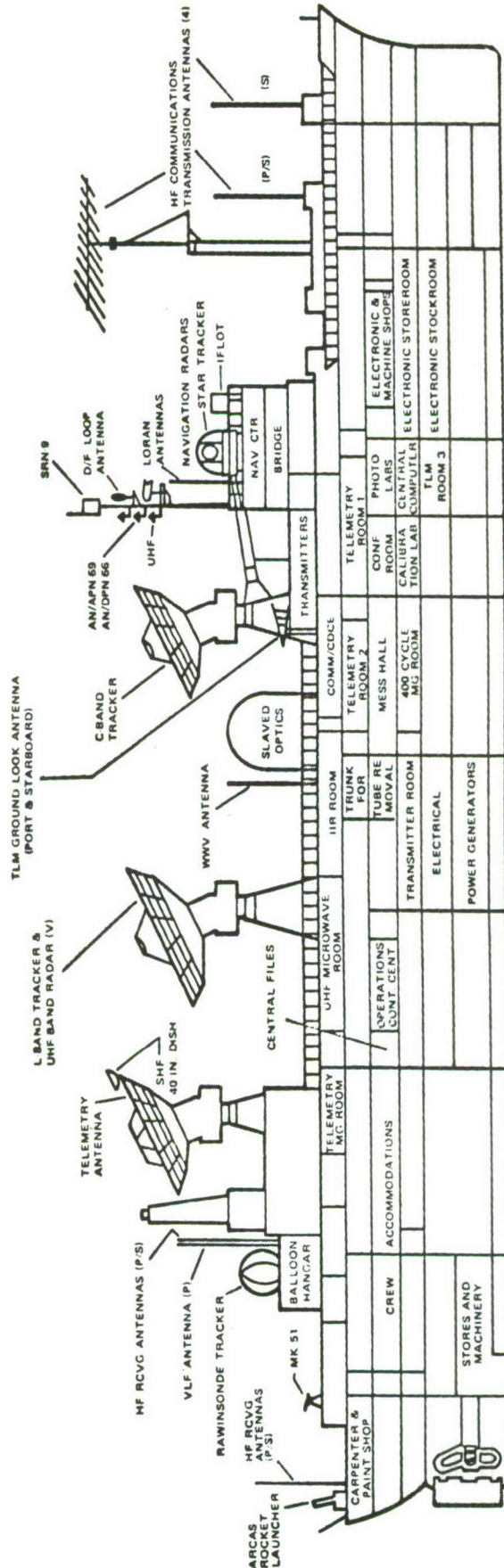

(V) H.S. VANDENBERG (T-AGM-10) ONLY

All subsystem operational status and selected data displays are channeled into the OCC and are used by the Ship Operations Manager and the Ship Instrumentation Manager on the MCC, and the Designate Controller on the DCC to conduct the test and evaluate the operation.

The MCC provides displays of ship's heading, speed and position, television monitor of radar target track, status and mode indicators for the various systems, master tracker selected and the position (deck angles) of the selected master. The master countdown clock and controls and two intercom stations are on this console. The intercom stations provide selectable local instrumentation nets a tie-in with the communications center for off-ship radio communications.

The DCC displays status for all systems which can be selected from this console as master for control of the designate bus. The selectable masters on the ARIS ships are radar, telemetry, computer, star tracker, MK-51 optical director and IFLOT. The on-track or off-track conditions of the radars and telemetry are displayed on the console along with the position (deck angles) of the master selected. A countdown clock and communications panel are provided. Radar A-scope displays, TV monitors and radar range displays also appear on the OCC.

The TTP is a 30 x 30 in. vertical plotting board with dual plot capability. Chordal range versus height and delta latitude versus delta longitude are the missile trajectory quantities plotted. Input data for these plots comes from the central computer. To provide a magnified plot of the last part of a trajectory, the computer changes TTP scale factors when ground range becomes less than a specified limit.

Integrated Instrumentation Radar (IIR)

The ARIS IIR is an integrated radar system composed of independent C and L-band tracking radars which provide tracking and target signature (cross-section) data and on the Vandenberg, a slaved UHF radar which provides signature data only. At C-band, signature data is collected on two polarizations, along with cross-polarization data, while target tracking is carried out by the horizontally polarized channel. At L-band, a horizontally polarized channel is used for both tracking and signature data.

The antenna for the C-band systems is a 30-ft diameter parabolic reflector having both horizontal and vertical polarization capabilities. A hyperbolic subreflector is used in a Cassegrainian configuration; it is reflective to horizontally polarized signals but transparent to vertically polarized signals. The vertical feed is located at the focal point and transmits through the Cassegrainian subreflector. The C-band tracking radar employs a horizontally polarized monopulse feed located at the parabola apex for developing angle tracking information on skin or beacon targets. The C-band antenna includes an auxiliary 4-ft dish for side lobe blanking. The tracker can provide precise skin track of

targets when the target signal-to-noise ratio is 12 db or greater and provide early acquisition, long-range track on beacon targets. Digital range units provide unambiguous data up to 32,000 nautical miles with a range resolution of ± 2 yards.

The range data supplied to the computer is a 25-bit binary word. Deck angle data is derived from 19-bit digital shaft encoders which are mounted on the elevation and train axes of the mount.

The C-band tracking radar can track a skin or beacon return from a primary target and provide relative range and angle data on additional targets by means of post-flight data reduction techniques. The secondary target must be within the track cell of the C-band radar; i.e. within ± 0.2 degrees in angle and $\pm 32,000$ yards in range of the primary target. In addition, the secondary target must be separated in range from the primary target by at least 100 yards. Target slant range resolution of 100 yards is accomplished through pulse compression. A skin pulse of 30 microseconds is compressed to less than 1 microsecond in the receivers before angle error and signature data are extracted.

The C-band tracking radar can acquire a target by using designate data supplied by the L-band radar, telemetry tracker, star tracker, MK-51 director, IFLOT; by the computer using the theoretical orbital elements, or by local radar console operation of handwheels. The computer is the primary source of designate and acquisition data. A scan pattern is superimposed upon the designate point to enhance the probability of acquisition. Early target acquisition is enhanced by the simultaneous beacon interrogation mode (selectable), allowing interrogation pulses from both the horizontal and vertical channels at the same time. A video double threshold detector provides a 99.9 percent probability of detection of targets having a signal-to-noise ratio of 10 db or greater.

In addition to target tracking, the C-band radar provides target illumination for cross-section data. Horizontally and vertically polarized energy at a peak power of 1 megawatt is transmitted by interlaced pulses. Each polarization uses a PRF of 160. Both normal and cross-polarized returns are received and recorded.

The L-band antenna on each ship is a 40-ft diameter parabolic dish with a Cassegrainian feed for horizontally polarized transmission and reception. The L-band single channel radar operates as an independent tracking radar providing both metric and signature data. The radar tracks in the skin mode only. L-band peak power output is 8 megawatts, PRF 160, and the pulsewidth is 30 microseconds compressed to 0.6 microseconds at 4 db. The L-band tracker employs a 32,000 nm unambiguous digital range machine which provides 25-bit digital range with a resolution of ± 2 yards. The tracker can track one target during mission time and record video data on all targets seen within the track envelope, which is defined as within ± 48 nm, ± 16 nm of the primary target in range and within the 1.3 degree beamwidth of the radar.

The UHF radar aboard the Vandenberg shares the 40-ft antenna with the L-band radar. This system provides a 12 megawatt peak power output for vertically polarized transmission. The radar is used to gather signature data on targets being tracked by the L-band radar. The radar operates at a PRF of 160, a 30 microsecond pulsewidth, and is equipped with pulse compression. The UHF feed is a radome covered pyramided focal horn. Vertically polarized UHF signals emitted by the horn pass through the L-band subreflector to the main reflector and are radiated into space. Reception of UHF signals is the reverse of the transmission process. Both ARIS are scheduled to be equipped with a new phase coherent UHF radar as part of a scheduled improvement program.

Radar data is recorded by the ship's data handling subsystem for post-flight processing at the AFETR. Metric data is recorded in digital form and consists of antenna train and elevation position referenced to the deck plane of the ship and slant range to the target. Peak detected (or box car) video is digitized in real time and recorded along with the metric data to provide prime target signature data.

Raw video data are recorded on video tape with the necessary reference information for post-flight processing. These data provide both amplitude and angle error information on secondary targets with the radar beamwidth and range cell. Amplitude information relates to the target radar cross-section and is a prime factor in determining target signature. Angle error information relates to target position within the radar beam and is needed to determine the true level of the reflected radar signal.

Telemetry

The ARIS telemetry subsystem serves a dual purpose: (1) as an automatic tracker it provides angular data that can be put on the master designate bus to assist the radars in acquiring a target, and (2) as a data collecting and recording system it provides telemetry data in the standard telemetry bands within the frequency range 216-965 MHz and 2185-2310 MHz. The ARIS also carry special telemetry equipment to collect data within the 60-4000 MHz region.

The telemetry tracking antenna employs a dual-element log periodic broadband feed system for frequencies from 215-2300 MHz (19 db-38 gain, respectively). One element receives right circular polarized (RCP) signals and other receives left circular (LCP) polarization. The conical scan rate of 1200 rpm produces a 20 Hz error signal for auto-track. The system can track on either RCP, LCP, or in a combined mode, using a 30-ft parabolic dish mounted on an antenna mount identical to the radar mounts. The antenna mount can be slaved to the designate bus controlled by the master selected in the OCC, or can control this bus, if selected as master.

The TRKI-12 system is used for receiving and recording telemetry data. The TRKI-12 system consists of 12 telemetry data receivers, six spectrum display units, six diversity combiners, six predetection converters, two predetection playback monitors, two FR-1400 magnetic tape recorders, two direct-write recorders, one data insertion converter, one FM record/reproduce electronic unit, and the necessary test equipment and patching facilities.

Each telemetry data receiver provides reception of FM, PM and AM carriers and demodulation of FM, PDM, PAM, PCM, PACM and PM.

Separation and display equipment consists of a Time Division Multiplex Type II (TDM-II) station and TDM-II test unit, FM fixed discriminators, tunable discriminators, digital-to-analog converters (D/A), analog-to-digital converters (A/D), digital bargraph display, oscillographic recorders and direct-write recorders.

The TDM II derives primary and secondary synchronization from video signals for the reconstruction of the various modulated carriers using the basic PCM technique. The system will decommutate PCM at rates up to 1,000,000 bits per second. A PAM/PDM to PCM converter in the system converts a PAM or PDM wavetrain to PCM for decommutation of this type data.

The 18 FM fixed discriminators are Data Control System Model GFD-2 subcarrier discriminators with the necessary plug-ins for the discrimination of IRIG channels 1-18 and A-E. The five FM tunable discriminators are EMR Model 229 units that can be tuned to any desired frequency between 300 Hz and 300 kHz; frequency deviation of $\pm 7.5\%$ or $\pm 15\%$ can be selected. A Monitor Systems Model 2119 D/A converter (50 channels) converts parallel digital outputs from the TDM-II to analog form for recording and display, and a Monitor Systems Model 2239 A/D converter (48 channels) digitizes discriminator outputs for remote transmission and computer use.

A Monitor Systems Model 2321 digital bargraph (40 channels) converts parallel digital outputs from the TDM II and displays up to 40 channels of digital telemetry data in the form of vertical bars, each representing a data word. Four Minneapolis Honeywell Model 1612 recorders (18 channels each) are used for recording up to 54 channels of analog data at rates up to 5 kHz. Four Brush Instrument Mark 200 recorders (8 channels each) are used for recording up to 32 total channels of analog data at rates up to 58 Hz.

The Real Time Retransmission System consists of SPAC (Signal Processor and Conditioner), a part of the RTTDS (Real Time Telemetry Data System), and the High Speed Data Modem. The SPAC accepts up to three links of telemetry data from units such as the TDM II and A/D converter for storage and selection, or selected data from the 1206

computer for retransmission in near real time at a rate up to 2400 bits per second. (This rate is determined by the High Speed Data Modem and the HF link since the SPAC can accept up to 100,000 data words per second.)

A special telemetry system enables frequency coverage over a range from 60 MHz to 4,000 MHz. The system consists of: (1) SHF auto-track system, (2) RV receiving antenna system, (3) ground look antenna system, (4) control console, and (5) magnetic tape recorder system.

A 40-in. SHF autotrack antenna dish is mounted on top of the 30-ft telemetry antenna. The TWT preamp, filter and 20-db coupler are in a weathertight enclosure which is also on top of the 30-ft dish. The R-35 receiver is mounted in the RF enclosure on the back of the 30-ft dish. Although the receiver can tune from 2 to 4 GHz, the system will operate only between 2.665 GHz and 2.955 GHz because of the bandpass filter in front of the preamp.

The RV receiving antenna system consists of five antennas (including the primary 30-ft telemetry dish), six preamplifiers, five postamplifiers and 12 receivers. The five-antenna complex covers the frequency band of 60 MHz to 4 GHz. The six preamplifiers cover the same frequency band in five overlapping steps. The postamplifiers provide frequency coverage from 90 MHz to 4 GHz in five overlapping steps. The receivers cover the 60 MHz to 4 GHz band in four steps with a minimum of two receivers for each step. In addition, the system contains the necessary multiplexers, multicouplers, demodulators and converters for video and predetection display and recording.

The ground look antenna system consists of two separate systems, one mounted on the portside of the ship and the other mounted on the starboard side. They are individually controlled from the control console. The combined system consists of four antennas, five preamplifiers and eight receivers. The antennas cover the band of 60 MHz to 4 GHz in two steps. The preamplifiers cover this band in five overlapping steps, while the receivers cover the band in three overlapping steps. There is a minimum of one receiver for each band, and the system contains the necessary multiplexers, multicouplers, demodulators and converters for video and predetection display and recording.

The control console contains the necessary test, control and display equipment for operating the special telemetry system. In addition, it houses the receivers and postamplifiers that are a part of the RV and ground look antenna systems.

The tape recorder system consists of four CEC, VR-3600 one-inch tape recorders with 14 tracks each, and two CEC, VR-3600 one-half inch recorders with seven tracks each. Recording capabilities are from 400 Hz to 1.5 MHz on all tracks for either video or predetection recording.

Navigation/Stabilization

The ARIS navigation/stabilization subsystem consists of a MK III Mod 5 Ships Inertial Navigation System (SINS), a MK-19 gyrocompass, an acoustic ship positioning system (ASPS), an electromagnetic log, star tracker, navigation satellite system (AN-SRN-9), LORAN, LORAC, and DECCA, plus the necessary consoles, recorders and plotters. Flexure angles between the SINS reference and selected sensors caused by the non-rigidity of the ship's structure are provided by flexure monitor equipment.

The SINS outputs are computed values of latitude, longitude and ground speed plus roll, pitch and heading. SINS is a stabilization navigation system designed to operate on surface and underwater vessels. The system consists of a gimbal assembly mounting three orthogonal gyros and two horizontal accelerometers, and a gyro-monitor assembly mounted parallel to the azimuth axis to provide continuous monitoring of level gyro drift rates, accelerometer bias and platform tilts.

A special purpose computer in the console provides platform control, pre-navigation platform alignment and continuous solution to the navigation problem. The vertical established by the gyro-stabilized platform is the primary reference for on-board operation and, as recorded data, is the reference for all the collected data requiring an inertially referenced coordinate system. SINS attitude data is used to remove ship's attitude from the 1206 computer designate data and to provide a reference to transform radar deck elevation and bearing to a stable local vertical coordinate system. All other subsystem equipment provides either information for computations and correction of SINS errors, or is used as backup. Such errors as those caused by SINS gyro drift can be corrected if accurate position and heading fixes are obtained. The SINS provides precision navigation by extrapolating ship's position and heading between star tracker, sonar, satellites or other type position fixes.

The MK-19 gyrocompass provides ship's attitude (pitch, roll and heading). This information is available, and selectable by switch in the Nav Center for data recording and vertical reference in the event of a SINS failure.

The underwater Electromagnetic Log equipment (EM Log) consists of three basic assemblies: the sea valve, the rodometer and the indicator transmitter. The rodometer is lowered into the water through the sea valve. Sensing units on the rodometer, using the sea water as a conductor, electromagnetically sense the ship's speed through the water. The indicator transmitter converts the transducer data to speed and transmits it to various systems, including the SINS and MK-19 gyrocompass, to damp and smooth velocity output data.

The star tracker is a gyro-stabilized 2-axis star detection and tracking and heading system to update and correct the SINS position information. The deck angle (train and elevation) data output of the star tracker is fed to the computer for SINS updating and error correction. The star tracker is designated to a star by the 1206 computer, which designates the star to be tracked from a stored star table ephemeris. The ephemeris data, date of year, time of day, and ship's attitude and heading are used by the computer to generate the star designate data. When the computer receives a stable track indication, it reads in enough star tracker output data to calculate a line of position fix and passes it on to the next star track. In this manner, the star tracker, working with the SINS and the computer via the navigation program routine, supplies star fix data to update the SINS.

The flexure monitor equipment (FME) optically measures angular displacement (flexing) of the ship about three mutually orthogonal axes having a known orientation or alignment with the RIS system data reference; i.e. the SINS stable platform. The FME is composed of a control console and two similar equipment sets. One set measures twist, train and elevation flexure between the SINS star tracker mount and the C-band radar mount. The second set measures the same quantities between the C-band mount and the L (or L/UHF)-band radar mount. The monitor equipments employ a light source (transmitter) and light receiver operating in an enclosed light-tight tube. The twist monitor measures the amount of twist by detecting the change in light intensity at the receiver produced by the twist-induced rotation of light polarizers through which the light passes. The 2-axis monitor measures the displacement of the receiver lens assembly as the ship flexes longitudinally. Electronic circuits convert these optical quantities to AC signals and transmit them to the central data conversion equipment (CDCE) for recording, and on to the computer for calculations of compensating corrections which are then sent back to the mount servo systems. Geodetic locations of the beacons are established by obtaining ship's position fixes using the SINS, star tracker, SRN-9, etc. while simultaneously recording slant ranges to the sonar beacons. This procedure involves taking a large number of fixes while the ship travels in the beacon field. The calculations and computations are made by the 1206 computer. Random and systematic errors in ship position are minimized by the large quantity of fixes and the manner of navigating the beacon field.

The AN/SRN-9 navigation receiver provides access to the Navy navigation satellite system which enables the ship to obtain accurate navigation fixes from data collected during a single pass of an orbiting satellite.

In this system, orbiting satellites transmit digitally encoded information describing their orbits, synchronizing signals and an identification tone on phase modulated carrier frequencies of 150 MHz and 400 MHz. The transmitted information, combined with doppler shift in the transmitted frequencies caused by earth, satellite and ship motion, provides a means for computing ship position regardless of time-of-day, weather conditions or geographic location. The AN/SRN-9 receives, processes, and presents intercepted data in a form suitable for use by the 1206 computer, which then processes the data and provides an output of the ship's latitude and longitude.

The acoustic ship position system (ASPS) permits the ship to determine its position in relation to an array of sonar transponders which have previously been sown and accurately surveyed to provide earth-fixed geodetic reference points. The ASPS is used to measure the slant range to these sonar transponders anchored to the ocean floor. Each transponder consists of a receiver operating at 16 kHz, and a transmitter operating at a pre-set frequency between 9.5 and 12 kHz together with an associated battery pack. Upon ship's interrogation, each transponder (two or three transponders are usually employed) will respond on its individual preset frequency. The ship's equipment separates and identifies each of the signals to form a distinctive trace on a chart recorder measuring and displaying the slant range to the transponder. By means of the computer program, which determines the horizontal range of the ship from a point on the surface of the ocean directly above each transponder, the ship's sonar position is obtained.

Optical/Opto-Radiometric

GENERAL

Opto-radiometric equipment is used by the ETR to determine certain electro-magnetic radiation characteristics of missile flights and catastrophic events and to measure atmospheric attenuation. Data are obtained from that sector of the electromagnetic spectrum from the ultraviolet region (0.3 microns wavelength) into the infrared region (15 microns wavelength). The portion from 0.3 micron to 0.9 micron is covered by cinespectrographs, using transmission gratings to disperse the radiation, and spectrally filtered cine cameras with film emulsions to detect and record data. The infrared region is covered by radiometers, spectrometers, and interferometers using lead sulfide and thermistor detectors. Radiation measurements can be divided into three categories: (1) radiometric, total energy in a relative wide spectral interval, (2) spectral, total energy in a very narrow spectral interval, and (3) spatial, radiometric or spectral energy as a function of position within the field of view. Additionally, dimensional and shape data become important when resolved images are present.

Some typical types of opto-radiometric data provided are as follows:

- (1) Effective fireball, nosecone, and decoy temperature
- (2) Energy distribution of an explosive fireball
- (3) Radiant intensity
- (4) Spectral emission
- (5) Ablation rates
- (6) Thermal buildup and decay rates

The ARIS optical capability consists of boresight motion pictures, ballistic camera arrays, cinespectrograph, radiometry, image surveillance and high resolution/long focal length photography. Optical equipment is distributed between several pedestals: radar and telemetry tracking pedestals, manual IFLOT pedestal, and a precision slaved optics pedestal.

The slaved optics system is installed on the Arnold and planned for the Vandenberg. It is capable of recording cineradiometry in two bands (visible and near infrared), spectroscopy in three bands (near ultraviolet, visible and near infrared), and shape/size imagery in the visual band. The cineradiometers and cinespectrographs have day and night capability; the ballistic cameras and ballistic spectrographs have only a night capability; and the shape/size imaging system has a full daytime and partial nighttime (hot body only) capability.

The system also includes an optical calibration system consisting of a collimator, a calibrated tungsten lamp source, a mercury vapor spectral source, a black body source, and a system of selectable apertures and neutral density filters capable of providing complete intensity and spectral calibrations.

Data Handling

The ARIS data handling subsystem provides for the conversion, formatting and recording of ship collected metric and signature data and for the functions of target designation, navigation, calibration and checkout. A total capacity for processing 33 million bits of data per second exists.

Three major equipment groups make up the data handling subsystem. The first, data processing equipment includes the central computers, peripheral equipment and related software.

Video recording equipment provides redundant recording of all radar signature data and includes 2-in. magnetic tape units with associated electronics and buffers. Tape copies can also be made aboard ship.

The video tapes are played back at Patrick Air Force Base on the Data Playback and Digitizing Equipment (DPDE).

Data conversion equipment serves an interface for the processing and recording function by providing two-way conversions between digital and analog data, formatting digital data for recording and computer entry, routing data between subsystems for the tracking radars, and recording all prime target metric and signature data with SINS attitude and other reference data. C-band data on the Vandenberg is recorded on 1-in. tape and then transcribed to 1/2-in. tape in IBM format. The Arnold's C-band data, are recorded directly in IBM format on 1/2-in. tape. L-band data, on both ships, are recorded on 1/2-in. tape directly in IBM format.

The allocation of major equipments for the two ships is shown below.

<u>Equipment</u>	<u>USNS Arnold</u>	<u>USNS Vandenberg*</u>
Computers	1206, 642-B, 1230	1206 and 1230
Video Recorders	4 units	4 units
Data Conversion	CDCE, NDHIS, DRSB, DCISE	CDCE, DCISE

*Future plans call for upgrading this ship to the same configuration as the USNS Arnold.

CDCE - Central Data Conversion Equipment
 NDHIS - Navigation Data Handling Interface System
 DRSB - Digital Recording System Buffer
 DCISE - Data Conversion Interface and Switching Equipment

The computers perform their functions in the systems by the following major programs:

1. Navigation (NAV). Used before and after a launch to determine ship's position and heading. It uses SINS, sonar and star tracker data.
2. Designate, acquisition and track (DAT). Used during launch or orbital support to designate tracking sensors onto target, collection of mission data and impact prediction. During DAT, a limited part of the NAV program provides continuity of the navigation routine.
3. Data transcription. Used after the mission to transcribe mission data from the 1-in. magnetic RDR tape to IBM 7094 format on 1/2-in. magnetic tape (Vandenberg only).

4. Checkout. Used to check out the computers and associated DEP peripheral equipments, and the major subsystem interface.
5. Combined mount misalignment data collection and navigation calibration. Used to determine system misalignments.
6. Quick Look. Used after the mission to obtain cross information on the mission and calibration data.

Timing

Each ARIS Ship generates accurate timing signals with a timing subsystem to permit correlation of independent events, both internal and external to the ship. Dual crystal oscillators provide the timing base for time code generators which feed monitoring and distribution equipment to produce 23 digital codes, 39 mixed codes, 39 pulse rates and seven sine waves in the standard, approved IRIG format. Through reception of standard HF broadcast and the use of an on-board Cesium Beam Frequency Standard and Loran-C equipment, timing synchronization with CKAFS and Vandenberg AFB is maintained within ± 0.5 msec.

Digital time codes are used by the ship computer and for recording on pen recorders, oscillographs and camera film. Mixed codes, such as a 1-kHz sine wave modulated with a digital code, are used for recording on magnetic tape. Pulse repetition rates are provided for mixing with time codes to interpolate between code pulses and for use as driving pulses for instrumentation equipment. Sine waves provide reference frequencies.

Communications

This subsystem supplies both internal and external communications. Included in the interior equipment are a direct-dial electronic private automatic branch exchange (EPABX) telephone system with trunks for shore access, an intercom system with access from any instrumentation area to the RF links on established nets, a sound-powered phone system as emergency backup for internal communication and a PA system to cover instrumentation areas. Equipment in the VHF, UHF and HF bands provides ship-to-ship, ship-to-shore and ship-to-aircraft exterior communications. Patching is included to interchange equipments and antennas. Control of the entire subsystem is established from a Central Communications Console. A crypto facility is provided for encrypting messages as needed.

The UHF and VHF low power circuits provide communication between the ship and aircraft, harbor facilities and other ships. The HF (SSB) facility provides teletype, voice and data communication. The point-to-point teletype circuit provides a full duplex (simultaneous two-way)

capability. Encryption equipment is provided for classified message transmission and reception. Three special tunable 35-ft whip antennas, remotely controlled from the transmitter room, with a power handling ability of 10 kw, are used for HF communication. A high power rotatable 40 kw (PEP) log periodic antenna augments the transmission capabilities of the whip antennas.

The AN/FGC-60 Multiplexing System and Rixon data set are included in the subsystem to allow near real-time transmission of telemetry data up to 550 bits per second, via the HF transmitter, to other range stations. A high frequency data modem is used to transmit telemetry data at speeds up to 2400 hps via the HF transmitters to other range stations.

Marine communications are provided as required to meet maritime needs. This equipment, operated by the ship's crew, consists of interior voice networks and external radio communications.

Meteorology

High altitude weather data is obtained by balloon-borne radiosonde (to 100,000 ft). Shipboard equipment includes an AN/GMD-4 Rawin set which consists of a modified AN/GMD-2 Rawin Set and an automatic data processor. This allows the data to be received, corrected for ship's motion and heading and retransmitted via HF radio.

The AN/GMD-4 radar system tracks the balloon-borne instrument and processes the received information representing meteorological parameters. An 81.94 KHz modulation on the rawin transmitted carrier is detected by the balloon-borne radiosonde and used to modulate the signal from the radiosonde. The AN/GMD-4 derives range from this 81.94 KHz modulation by phase comparison of the modulations.

T2-SE-A2 (JUMBO)
USNS REDSTONE, T-AGM-20

The Range Instrumentation Ship, USNS Redstone (T-AGM-20), is configured to collect metric and telemetry data on missiles and space/orbital payloads on the Eastern Test Range (ETR). In addition to the radar and telemetry systems, equipment for measuring ship's position and attitude, providing timing, control, data handling and communications support, and for collecting surface and upper air meteorological data, allows independent operation in the Broad Ocean Areas of the Eastern Test Range.

The ship was constructed from a T-2 tanker hull removed from the "moth-balled" fleet. The modification consisted of enlarging the tanker hull by joining the original bow and stern sections to a new, larger midbody specially designed to accommodate instrumentation equipment, support equipment, stores and personnel.

The Redstone, although designed to provide general range support in remote locations, currently has two primary missions, with a third to be assigned in early 1972. It provides terminal area support for ballistic missile firings on the ETR, collecting metric trajectory and telemetry data from the reentry bodies, collecting terminal area meteorological data, and calibrating the Missile Impact Location Systems on the Range. It also provides support during the insertion and on-orbit phases of DoD spacecraft operations. In this role, it collects both metric and telemetric data and retransmits the information in real time back to range control centers for further application. The ship will be assigned the "Down Range Support Ship (DRSS)" mission subsequent to modifications planned for accomplishment during August-December 1971. In this role, the ship will collect metric and telemetry data from submarine-launched vehicles.

The vessel will also be provided with the capability of destructing missiles which deviate from pre-planned flight corridors.

The instrumentation complex of the Redstone consists of 10 basic systems, briefly described as follows:

Operations Control Center (OCC)

The OCC functions as the ship "command post" during tracking missions and system tests. This centralized control and coordination facility provides for smooth internal operations and assures proper integration of the ship into range network operations. The console in this control center is manned by the Ship Operations Manager (SOM), the Ship Instrumentation Manager (SIM) and the Designate Controller (DC).

During mission periods the SOM coordinates with other range network stations (shore, aircraft or other ships); assures correctness of ship's position, speed and headings; and monitors and controls the ship to support the mission. The SOM has a variety of radio and internal communications capabilities which include the range networks, the bridge, the SIM, the DC, shipboard instrumentation areas and an administrative telephone station. His console displays show ship position, heading and velocity, countdown and time-of-year.

The SIM position has communications and console displays of systems status and operating modes which enable him to monitor and control the shipboard instrumentation complex. He exchanges information with the SOM, DC and each instrumentation system. The DC Console displays tracking status of all antennas, the optical director and star tracker, and from this information and contact with each instrumentation system, the DC assigns or selects the stabilization and acquisition source for all antennas as called for in the mission plan. Other displays indicate the bearing and elevation of the selected acquisition source, ship's heading, countdown and time-of-year.

Also available in the OCC are two dual-arm 30" x 30" plotting boards which can display target position in Cartesian coordinates as determined by the computer from radar data, several strip chart and event recorders, a teletype pony circuit and a TV screen displaying radar TV boresight.

C-Band Radar

The Redstone's radar system consists of a modified AN/FPS-16 system with an additional selectable AN/FPS-26 high power transmitter, and an Advance Digital Range Machine (ADRAM). The radar is configured to provide trajectory data during near-earth orbits and transfer orbit insertion of beacon carrying spacecraft, or to skin track reentry bodies of low radar cross-section in the reentry and impact areas.

The antenna is a 16-ft parabolic reflector with a Cassegrainian multimode feed, capable of radiating and receiving from 5400 to 5900 MHz and with an antenna gain of 46 db in the sum channel. The group includes on-mount rate gyros for antenna stabilization. The pedestal is an elevation-over-azimuth two-axis system, rotating on hydrostatic bearings compensated for horizontal thrust components with an electrohydraulic drive. The RF head is located in the upper pedestal behind the feed assembly and contains IF preamplifiers, phase shifters, duplexer couplers, waveguide tuners and switches and AFC controls.

The transmitter group consists of an AN/FPS-26 transmitter (3 megawatts peak power), an AN/FPS-16 transmitter (1 megawatt peak power), common microwave components, and appropriate interfacing between the

two transmitters. Pulsewidth and beacon/skin mode controls are provided at the console, subject to limitations of the individual transmitters. Pulsewidth of the FPS-26 transmitter is selectable at 1, 5 or 10 usec. No beacon coding capability is provided on this transmitter. Pulsewidth of the FPS-16 transmitter is fixed at 1 usec. The latter transmitter has a beacon tracking capability with selectable coding and automatic beacon sequencing. The pulse repetition frequency (PRF) is fixed at 160 for both transmitters.

The receiver subsystem covers a frequency range of 5400 to 5900 MHz. Simultaneous reception of both skin and beacon targets is provided. In addition to the three receiver channels required for monopulse tracking, the radar uses an ungated video channel for console display, and to feed the digital range tracking and auxiliary tracking systems.

The Range Tracking subsystem is an all-electronic Advanced Digital Range Machine (ADRAM) which utilizes Nth-time-around techniques. In effect, targets can be tracked at ranges in excess of the radar time base by a multiple-time-around method, rather than by the reduction of the radar pulse recurrence frequency. The Range Tracking subsystem is divided into two parts. One, the range system, is capable of deriving continuous, unambiguous range tracking data on suitable targets to a maximum range of 32,000 nautical miles. The other, the Auxtrack system, provides automatic angle acquisition and track of targets which may be either beacon returns due to interrogation by the local or distant radar, or skin returns from the local radar.

Three modes are selectable to acquire a target. In the manual mode, the antenna is stabilized, and movement to acquire the target is accomplished by the use of handwheels. Analog scan patterns, generated by the Auxtrack subsystem, can be utilized to aid acquisition. In the synchro mode, pointing data is derived from the Acquisition-Stabilization Network (ASN). Analog scan patterns may also be used. The ASN normally drives pointing information from other on-board sensors. In the digital designate mode, pointing and stabilization data are derived from the CDPS based on nominal and/or in-flight trajectory information. Digitally developed scan patterns may be overlaid on the designate data.

Radar boresight camera film and films from cameras photographing an amplitude vs. range A-scope and an intensity vs. range scope are also available for post-flight analysis.

Telemetry

The telemetry system includes subsystems necessary to provide for the acquisition, detection and tracking of telemetry signals; reception

and recording of these signals; separation and demodulation of FM subcarriers, decommutation of PAM, PDM and PCM signals, and display of selected data in real-time and/or processing for retransmission to remote locations.

The Antenna Subsystem consists of four independent automatic tracking S-band Telemetry Antennas complete with individual acquisition aid antennas. The main antenna has a gain of 38 db and a system noise temperature of 280° K. Each antenna has azimuth travel limits of 750 degrees and elevation travel limits of minus 11 degrees to plus 105 degrees. The antenna is capable of tracking rates of 40 degrees per second and acceleration rates of 30 degrees per second in both axes. The above rates for elevation apply only between zero and 90 degrees with rate limiting applied beyond these limits. Included with each antenna are two preamplifiers (right and left circular polarization), two down converters, multicouplers, auxiliary test equipment and two dual channel tracking receivers with both narrow and wide band tracking modes. The down converters convert the S-Band frequencies to the 300-400 MHz frequency range. The antennas are locally stabilized by coordinate converter packages using ship's attitude inputs from the SPAMS.

The Antenna Subsystem, via digital encoders, provide the Central Data Processing System (CDPS) with elevation and azimuth antenna position data. The CDPS contains a telemetry buffer which interfaces the antennas with the UNIVAC 1230 Computer. Each antenna accepts digital designate data from the computer, by way of the telemetry data buffer, independent of the other antennas. Each antenna is capable of operating in the following modes: standby, manual, autotrack, forced track, and computer designate. In addition, each antenna can be operated in the manual mode with internally generated analog scans and in the computer designate mode with computer generated digital scans.

The Central Data Processing System provide pointing angles for the Antenna Subsystem. The pointing angles are derived by the computer from launch platform position data from the LASS and from DRSS position data from SPAMS.

The S-Band Receiver Subsystem consists of two receiver portions of two TRKI-12 receive/record stations. It consists primarily of 24 receivers, 12 diversity combiners, 12 predetection down converters, 14 local patch panels, 2 video IF patching cabinets and two test equipment cabinets.

The recording Subsystem consists of five 14-track magnetic tape recorders. This system consists of FM record electronics, recorder test equipment, data insertion converters, pre-detection up-converter, and predetection playback monitors from the Recording Subsystem of two TRKI-12 systems.

The Data Separation and Decommutation Subsystem consists primarily of TDM-1, one TDM-1a, a digital bargraph, twelve fixed frequency

discriminators, eighteen tunable discriminators, four oscillographs, seven pen recorders, one data insertion converter, A/D converters, D/A converters, a Signal Processor and Conditioner (SPAC), and associated test equipment.

In the Data Separation and Decommulation Subsystem, standard IRIG, PAM, PCM and PDM commutated data is decommutated by the TDM-I and IA. Outputs from this subsystem are patched to the pen recorders.

Data to be retransmitted in real or near-real time is processed through the Signal Processor and Conditioner (SPAC) after demultiplexing in the TDM-iA. This system conditions and reformats the data into parallel data streams for retransmission over the high-speed HF data link to remote stations. Data modems and transmission facilities are part of the Communications system. Data may be shifted out of the SPAC at rates up to 2400 bits per second. Telemetry data recorded in video form on magnetic tape recorders may be retransmitted to aircraft or close-range bases through a VHF retransmission system. Due to noise introduced in the recording, retransmission and subsequent re-recording, this data is normally used only for quick-look analysis.

Ship Position and Attitude Measurement

The Ship Position and Attitude Measurement System (SPAMS) provides continuous and accurate data of ship's attitude (roll and pitch relative to the local vertical, and heading relative to north), velocity (inertial components north, east and vertical), and position (latitude and longitude) to the CDPS during test support. Accurate reduction of C-band radar tracking data is provided using this position and angular reference data. The SPAMS reference data also provides the reference point for ship navigation and control when reaching a test support position performing survey functions and during target acquisition. SPAMS provides data for stabilization of shipboard antenna systems and for conversion of information from deck-referenced to earth-referenced coordinates. In addition, it provides a measurement of ship velocity and tracking system antenna mount flexure.

The key equipment in the SPAMS is the Sperry MK-3, Mod 5 SINS, which accurately measures changes in latitude and longitude and continuously references ship's attitude against local vertical and true north. Three mutually orthogonal axes are required as a reference for measurement of all shipboard tracking angles and these axes are established by the SINS. The SINS binnacle, which houses eight inertial components (gyros and accelerometers) in a thermally stable environment isolated from ship's motion by a three-gimbal arrangement, is mounted on a specially designed bedplate supported by rigid ship's structure. The inertial components, gyros and accelerometers in the system are not error-free, thus, their outputs will degrade with time. These errors (i.e. gyro drift) can be corrected by reset when position or heading information from another source is known. The star tracker, satellite

navigation receiver, sonar benchmark equipment and Loran-C information are used for this purpose.

The MINDAC computer is a digital computer whose primary functions include calibration routines, latitude compensations, compensation for earth turning rates, and to accept accelerometer information and process this data to produce the needed navigational outputs and platform control signals. The computer also accepts reset information from other sources and inserts these values into the navigation program.

The marine star tracker consists of two units: the optical tracking unit, containing the above deck optics, and the below deck tracker electronics. The star tracker provides accurate measurement of the elevation and azimuth of a star, or stars, with respect to the ship. The computer uses this information to calculate ship's position and heading for use as SINS reset information. When designated to point a star by the computer from a stored star catalog, the star tracker is capable of automatically acquiring and tracking the star. The star tracker will track stars during the day, as well as at night.

Another equipment in the SPAMS is the MK-19 Gyrocompass. The outputs of the MK-19 are the ship's roll, pitch and heading; however, the equipment is considerably less accurate than the SINS. The MK-19, together with the EM Log, serves as backup to the INS for position and velocity information and for stabilization in the instrumentation complex.

The EM Log measures the ship's velocity relative to the water. Inputs of north and east components are sent to the computer via the MK-19. These quantities are multiplied by the increment of time since the last calculation and added to the running sums to give ship's present position. The EM Log's measurement of the ship's speed through the water, along a fore-and-aft axis, is used for velocity damping by both the INS and MK-19. Output of the EM Log is also fed to ship's speed indicators at various stations throughout the ship.

The bathymetric navigation or sonar benchmark equipment enables the ship to determine its position (latitude and longitude) in relation to bottom "benchmarks", sonar beacons which have previously been sown and surveyed. If a beacon field does not already exist, the ship selects a suitable area at the TSP (Test Support Position) by use of depth sounding and precision fathometer equipments and sows two or more sonar beacons. The geodetic location of the beacons is established by obtaining ship's celestial position fixes, using the star tracker, SINS, etc., while simultaneously recording slant ranges to the beacons. This procedure is accomplished prior to mission support and involves taking a large number of fixes while the ship steams in the beacon field area. During the actual mission support period, the ship position and information for SINS reset is obtained by interrogation of the bottom beacons,

measurement of the slant range to each beacon, and computer computation of the ship position with respect to these earth-fixed references.

An Acoustic Ship Positioning System (ASPS) is also temporarily installed aboard the Redstone. This system also accurately measures slant ranges between the ship and bottom beacons. Accuracies of this system have been well established, and it has been installed to provide a reference for evaluating the sonar benchmark (bathymetric navigation) equipment.

Other navigation devices in the SPAMS are the AN/SRN-9 and AN/BRN-3 Navigation Satellite Receivers. Both systems receive digitally-encoded information describing the orbit of one of the Navy navigation satellites synchronizing signals and an identification tone. The transmitted information, combined with doppler shift, provides an all-weather means for computing ship's position. SRN-9 outputs are fed to the CDP computer for computation, while the BRN-3 contains its own computer for deriving ship position. Again, the fixes are used to reset SINS.

Loran-C is also a part of the SPAMS. This equipment is also installed to provide position fixes for the reset of the SINS.

The Flexure Monitor system is an optical-laser system provide to continuously and automatically measure the ship's flexure, bending and twisting, between the optical reference cube mounted on the SINS bed-plate and the C-Band radar antenna mount. The flexure information, in digital form, is continually fed to the CDP computer where it is used to correct C-Band tracking information.

CENTRAL DATA PROCESSING SYSTEM (CDP)

The Central Data Processing System (CDP) consists of a Univac Type 1230 digital computer, associated peripheral equipment and buffers which interface the computer with instrumentation complex equipments.

The Univac Type 1230 (modified CP-642B) general purpose digital computer provides a random access memory for 32, 608 30-bit words, 16 input and 16 output channels of 30-bit words, and a cycle times of 2 microseconds and 1 microsecond with memory overlap. The peripheral equipment includes: one 2-deck and one 4-deck Univac 1240 magnetic tape unit, a Univac 1232A Input-Output Console, a teletype Model 28 Teletypewriter Set (ASR) with Univac 1259 adapter, a Data Products 4120, 600-line/min high-speed printer, raw data recorder and interface buffers to instrumentation equipments.

The Central Data Processing System receives ship's position and attitude data, Timing System signals, antenna pedestal flexure data, control signals, target acquisition information, and real-time tracking data. It processes the received information to provide data for antenna pointing, ship's position and attitude, trajectory data recording and display, plotting board tracing, target acquisition, and data

transmission. Primary operations are accomplished in Standby, Acquisition and Tracking Modes under the management of resident control and executive programs which optimize computer time and priorities. Auxiliary routines and subroutines provide standard library, marine survey, data reduction, system analysis, and checkout routines. Diagnostic routines are provided to facilitate trouble analysis.

Timing

The USNS Redstone timing system generates and distributes standard frequencies, time codes and repetition rates for use by shipboard instrumentation. The basic timing equipments are located in the communications and timing center room. Timing system leading particulars are as follows:

1. System outputs - 5 MHz, 1 MHz and 100 KHz; pulses - 2 pps, 20 pps, 400 pps, 2 ppm and 10 ppm; and tune signals - BCD time of year to 0.1 sec, serial binary time-of-year to 0.1 sec time codes IRIG A-E, NASA 1/sec, 1/min, 1/hr and serial decimal; sinusoidal signals; square waves correlated to a 1 pps on-time signal; and square waves delayed with respect to the 1 pps on-time signal by selectable amounts; all based on rubidium standard.
2. Cesium beam frequency standard "clock" - Hewlett Packard Model 5061 in system; off-line, as master clock for reference and synchronization. Drift 0.4 microsecond per day.
3. Rubidium frequency standard - long-term stability 5 parts in 10^{11} per year, short-term stability 1 part in 10^9 per sec.
4. Crystal oscillator - long-term stability 1 part in 10^{10} per day, short-term stability 1 part in 10^{10} per second.

Frequency and time generation are redundant with manual on-line selection and electronic, transient-free, failure alarms and switchovers. Rechargeable emergency batteries and electronic power switchover circuits permit operation of essential system functions for up to eight hours in the event of a primary power failure.

A WWV receiver is on board to receive standard time broadcasts from the National Bureau of Standards broadcasts. Outputs are time-of-day in voice and synchronization pulses. A VLF receiver receives standard frequency broadcasts in the 10 to 30 KHz frequency range. Outputs from this receiver show the phase relationship between the received signal and the reference frequencies from the local frequency source.

Acquisition and Stabilization Network

The Acquisition and Stabilization Network (ASN) provides target acquisition and antenna stabilization signals required to interconnect, position and stabilize the tracking and remotely controlled directional antennas on the ship. The system may be controlled centrally from the Operations Control Center or locally at the individual antenna consoles. The prime designation source may be either the CDP computer, C-Band antenna, optical director or the telemetry antenna. Any or all of the remaining antennas may then be slaved to the prime designation source for acquisition purposes. The star tracker may also be slaved to the prime designation source.

In general, initial acquisition is accomplished in either of two ways. Designation data are stabilized deck coordinates generated in the CDP and transmitted via the Acquisition Subnetwork to the selected antennas. The alternate mode of operation is to manually order antenna position from handwheels at one of the individual antenna control areas. These data are transmitted to the computer, stabilized, then transmitted back to selected antennas via the Stabilization Subnetwork. When lock-on is accomplished and automatic tracking begins, on-track signals are transmitted to the pertinent consoles via the On-Track Subnetwork. The designate controller in the OCC receives the on-track data from the designate sources and assigns the master antenna for the acquisition and tracking bus.

The system has an optical acquisition aid and four principal subnetworks: Ship's Heading, On-Track, Stabilization and Acquisition Subnetworks. The Ship's Heading Subnetwork serves as a central distribution source for ship's heading indication. The On-Track Subnetwork receives the on-track signals from systems in automatic track and distributes these signals to all other tracking systems to indicate tracking status. Two on-track signals, bearing and elevation, are received from all active tracking elements except the optical director, from which only one on-track signal is received. The Stabilization Subnetwork provides computer-stabilized ordered position to selected antennas from any particular manually ordered antenna console. The purpose of the Acquisition Sub-network is to provide designation data to the selected antennas. Selection of a prime designation source is made at the Operations Control Center by the Designate Controller or at the individual system antenna consoles by the operators.

Meteorology

The USNS Redstone, like other AFETR stations, collects and records weather data to determine its effect on a given mission and to predict weather conditions for future scheduling and planning. Both surface weather data (wind speed and direction, temperatures, pressures, etc.)

and high altitude data are collected. The high altitude data, up to 100,000 feet, is collected by use of a balloon-borne sensor which is tracked by an AN/GMD-4 Rawin set.

The ship's meteorological equipment includes the AN/GMD-4 with Model 3703 Meteorological Data Processor, an AN/TMQ-5 Radiosonde Recorder and a balloon inflation hanger on the after deck.

Communications

Included in the instrumentation communications system are a radio subsystem, an interphone subsystem, a dial telephone subsystem and an entertainment subsystem.

The radio subsystem provides radio communications in the HF, VHF and UHF bands with voice, radio telegraph, radio teletype and high-speed data transmission capabilities. The HF facility serves as a long-haul or point-to-point, ship-to-shore voice, teletype and data transmission medium. Full crypto facilities are available. The VHF facility serves as a short-haul ship-to-ship or ship-to-aircraft voice medium. A VHF capability for post-mission retransmission of telemetry video to nearby range aircraft is also installed. The UHF facility serves as a line-of-sight ship-to-aircraft voice medium. A VHF homing beacon is included to permit aircraft to use the VHF facility as a navigation aid. An LF-VLF receiver provides for the reception of VLF teletype and CW signals. An HF Ionospheric Sounder Receiver is used in conjunction with one of a number of shore sounder transmitters and displays the usable frequencies at a given time between the ship and the sounder transmitter being received.

Radio Subsystem equipments include:

- (1) 6 each HF, 10 KW PEP, 2-32 MHz, SSB Transmitters (TMC TSTE)
- (2) 7 each HF SSB Receivers (TMC DDDR-506)
- (3) 3 each General Purpose Receivers (Collins 51S-1F)
- (4) 4 each UHF Transceivers, 100 W
- (5) 2 each VHF Transceivers 20W
- (6) 6 each VHF portable, 2 W Transceivers
- (7) 1 each Telemetry VHF Retransmission System
- (8) 1 each Ionospheric Sounder Receiver

SHIPS

- (9) 1 each LF-VLF Receiver (15-1600 KHz)
- (10) Crypto Facility
- (11) 2 TTY Multiplex Terminals, TTY Tonekeyers, Converters, and a quantity of KSR, ASR, etc.
- (12) 2 HF Log Periodic 10 KW Transmitting Antennas
- (13) 2 35 foot whip antennas
- (14) 1 HF tunable 10 KW Whip Transmitting Antenna
- (15) 6 each HF Receiving Whip Antennas
- (16) Various VHF, UHF transmit-receive antennas (dipole, co-linear) arrays, etc.)
- (17) Digital Data Transmission Set including two AN/USC-12A Data Modems, one Data Modem Test Set, and two Forward Error Detection and Correction Sets (FEDAC).
- (18) One Dual Channel Encryption Equipment
- (19) Two Data Modems

The interphone subsystem provides the flexibility and service required to support operational missions. The communications subcircuits are the conference loop type affording talk and/or monitor access at the control of the operators. Normally, each of the operators is assigned to monitor one loop and can be given talk and/or monitor capability of the other loops as required. These are two types of conference loops: local type and radio interface, which vary from 12 to 24-position capability each.

The dial telephone system is for general administrative and logistic support use. The dial telephone (PABX) switchboard provides, in addition to the normal 3-digit shipboard extension dialing system (a secondary communication system) a capability for patching into the interphone conference loops, and a radio communications link to a ship extension number. In port, an umbilical cable connects the subsystem to shore lines.

The entertainment subsystem consists of a radio broadcast antenna and a distribution facility to all staterooms, a television antenna system, and television antenna distribution facility to lounges and messrooms.

Command Destruct System (CDS)

The Command Destruct System provides the capability for downrange missile flight termination upon request from the Flight Safety Officer (FSO) aboard the Launch Area Support Ship (LASS). The CDS is a redundant system with automatic and manual switchover to standby equipment upon failure detection.

The Transmitter Subsystem consists basically of the following: (a) redundant transmitter groups with each group containing a tone coder, an RF exciter, and a power amplifier; and (b) an RF Switching and Dummy Load Assembly. The solid state crystal controlled exciters generate the basic RF frequency and provide frequency modulation of the carrier from the output of the tone coders. The power amplifiers provide ten kilowatts output from the exciter input. This ten kilowatts of continuous wave (CW) RF power is routed to the antenna subsystem by way of the RF Switching and Dummy Load Assembly.

The RF Switching and Dummy Load Assembly provides: (a) manual switching of exciter outputs to dummy loads and power amplifiers and (b) automatic and manual switching of power amplifier outputs to the antennas and dummy loads. The Transmitter Subsystem accepts input commands and control signals from the Control Subsystem and FSO console by way of a system patch panel. Status and display signals are generated by the Transmitter Subsystem and supplied to various subsystems for verification of commands and control functions.

The Antenna Subsystem consists of two UHF environmentally protected (radome enclosed) helical antennas. The antennas accept the ten kilowatts output power from either of the power amplifiers and radiates the energy into space. Only one antenna will radiate at a given time.

The local Monitoring Subsystem consists primarily of two receiver/decoder units, operations recorder, a power meter and recorder, and miscellaneous test equipment.

One receiver/decoder unit is provided for each power amplifier. The detected outputs are routed to the Function Keying Subsystem, by way of the system patch panel, for verification of transmitted commands and detection of failures.

One power level recorder and meter is provided to monitor and record the carrier level output of the power amplifier connected to the antenna. Detection of low power output will result in switchover to the standby transmitter group, in automatic operation.

The Function Keying Subsystem consists of two function keyers, two function detectors, and a comparator. The function keyers provide the keying for the tone oscillators (coders), by way of the System Patch Assembly, upon command request from the LASS or local Flight Safety Officer.

The function detectors accept the outputs from the receiver/decoder units by way of the System Patch Panel. These signals are detected and compared in the comparator with arm and destruct signals sent to the function keyers. If detected signals are different from commanded signals, the comparator will automatically cause switch-over to the standby unit.

The Control Subsystem consists basically of an operator console containing an RF transmission status and control panel, a function test panel, a communication panel, plus various recorders associated with other subsystems and the system patch panel. The RF transmission status and control panel provides status and control indications of the dual RF exciters and power amplifiers with their associated dummy loads and antennas. This panel permits system operation in either full standby mode, with automatic switchover upon failure detection, or non-standby mode, which requires operator selection of standby equipment. Each exciter is manually switchable into either power amplifier or into a dummy load. Each power amplifier can be automatically and manually switched into the antenna or dummy load, or both to dummy loads. Status displays provide the operator with complete system configuration information. The function test panel permits system checkout prior to transfer of control to the local or LASS Flight Safety Officer.

The System Patch Panel is provided to facilitate interconnection of coding and decoding interfaces, external control and status interfaces, and external command functions.

The remote Monitor and Control Subsystem (FSO) console, consists of one bay with a command control status panel plus miscellaneous communication and data displays. This console provides range safety command functions and is under the direction of the LASS Flight Safety Officer during normal DRSS operation.

Search & Recovery Boat

The ETR operates a search and recovery boat to locate and recover missile components that fall in the ocean off Cape Kennedy Air Force Station. This recovery boat is a 115 ft LCU. The LCU is outfitted to carry two devices for surveying the ocean floor plus navigation and radio communications equipment.

The LCU is also equipped to support Scuba divers to attach the LCU lifting devices to items to be recovered.

The C MK-1 Reconnaissance and Surveillance System used on the LCU consists of a shipboard console and a towed underwater vehicle.

SHIPS

The system is designed to locate and classify objects lying on the bottom in harbors or channels. It scans the bottom with beams of ultrasonic energy generated by transducers in the underwater vehicle. A permanent record of the information gathered is made on a paper recorder in the console. This record provides a shadowgraph representation of the bottom, allowing the operator to view objects lying on the bottom and classify these objects. When an item of interest is located, provision is made to release an area marker from the vehicle.

The console for this system is installed in a transportable shelter. This shelter is placed on the LCU with a crane, for each mission.

The EG&G Side Scan Sonar System consists of a dual oceanographic recorder, a tow fish, and the associated cables. This system is battery operated and fully portable.

The tow fish is towed in the water out to the side of the boat. It contains two sets of transducers which aim two fan-shaped beams to either side of the tow fish, perpendicular to the direction of fish motion. The transducers transmit sound pulses which echo off objects, and these echoes are processed and recorded graphically to produce a continuous acoustic "picture" of the ocean floor.

AIRCRAFT

AFETR instrumented aircraft perform electronic and optical data acquisition and processing for NASA and DOD tests and operations. There are two types of aircraft that are used as airborne platforms for three different types of instrumentations systems. The aircraft types are the NKC-135A and the EC-135N. The suffix "N" means the aircraft does not have to be returned to its basic configuration. The types of instrumentation systems are the following:

- ARIA -- Apollo Range Instrumentation Aircraft
- AACS -- Airborne Astrographic Camera System
- TRAP -- Terminal Radiation Program

Detailed information on these systems is available from the Aircraft Operations Division (RSO), and the Aircraft Engineering Division (ENN) at Patrick Air Force Base.

The aircraft type and tail numbers are correlated to the instrumentation system in the table below:

<u>NKC-135A</u>	<u>EC-135N</u>
<u>TRAP</u>	<u>AACS</u>
55-3127 55-3134	60-376
<u>AACS</u>	<u>ARIA</u>
55-3135	60-372 60-374 60-375
	61-326 61-327 61-328 61-329 61-330

APOLLO RANGE INSTRUMENTATION AIRCRAFT (ARIA)

The Apollo/Range Instrumentation Aircraft (ARIA) are airborne telemetry receive/record and voice relay (up and down) stations. Each of the EC-135Ns is equipped with the following instrumentation:

Antenna tracking: 7-ft parabolic dish equipped for Unified S-Band (USB), UHF(S-band, L-band), and VHF (P-band) polarization diversity.

Antenna wing probes: 2 each for HF communications

Antenna: Long wire for HF communications

Receivers: UHF/VHF tracking, four-dual (sum difference)

Receivers: UHF/VHF data, seven-dual (polarization diversity)

Recorders, Data 2 ea, 14-track, 0-500 kHz FM record, or 5 kHz to 1.5 MHz, direct record (pre- and post-detection)

Recorder, Voice: 1 ea, 7-track, 300 Hz to 3 kHz direct

Timing: Dual system, AMR/IRIG/NASA codes, atomic freq. standard

Data Transfer: 1 link UHF, 0.5 watt; 1 link VHF, 0.5 watt

Voice Relay

S/C to A/C: VHF/AM - simplex and UHF-USB duplex;

A/C to ground: HF-SSB, duplex (HF 1 kw, VHF 100 w, UHF 100 w)

Teletype: Two 65-100 wpm page printers, 1 tape perforator, 1 tape reader

Acquisition Sys: Bar scan or manual using pre-computer look angles

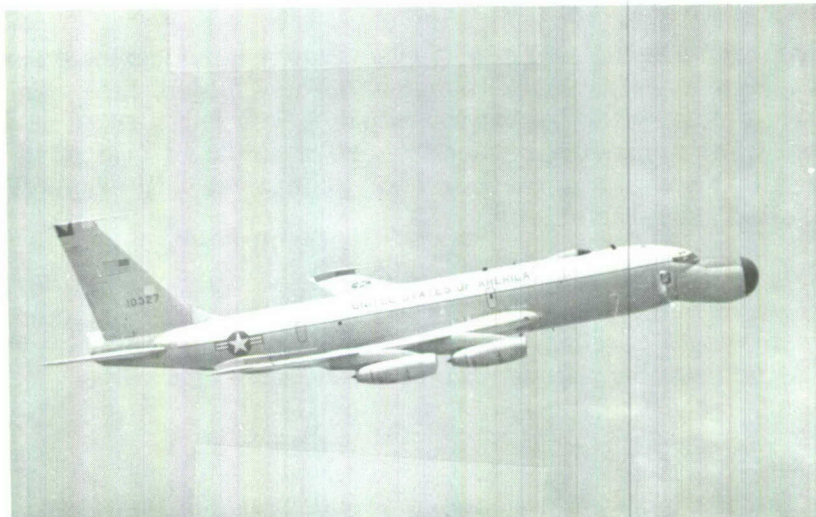

ARIA

Each ARIA timing system consists of two identical timebase generators, one serving as backup. These generators produce time codes and repetition rates which are clocked and compared. An alarm sounds when a dissimilarity between generators is detected. The other dual time-base generator may be substituted manually or be previously patched into the recorders for redundant timing. The primary oscillator on this system is an atomic standard (rubidium) with a stability of 1 part in 10^{-11} per day. Normal synchronization is via WWV to approximately ± 1 msec. However, synchronization on the order of 50 μ sec can be obtained with special preparation.

The ARIA dual timing generator produces IRIG, AMR, and NASA codes. Up to seven codes or repetition rates can be selected at the patch panel for distribution. Five IRIG standard formats are generated which are pulse width modulated (A, B, C, D, E). No permuted IRIG formats are generated.

Two AMR codes are available, B-1 and D-1.

Three NASA codes are generated: 36-bit BCD (100 pps), 28-bit BCD (2pps), and serial decimal code.

Twenty eight precision repetition rates are generated from 100K pps on time to 1 pps on time.

Five repetition rates (1 pps, 10 pps, 100 pps, 1000 pps, and 10,000 pps) are available with variable delays.

COUNT-DOWN TIME (GROUND ELAPSED TIME, GET)

The aircraft that have the IRIG type IV timing system also have a countdown indicator with displays on the flight deck and in the instrumentation area. The count is manually set in by the operator according to a mark received by radio communications. The count progresses to zero and then in a positive accumulation by counting the 1 pps out of the time code generator. All displays are automatically controlled from the driver.

The ARIA contains a Ground Elapsed Time (GET) indicator alongside all the GMT indicators at each operator's position. The GET count is initialized manually at the timing console, and progresses up or down in count as desired. The mission coordinator console has control over the start and stop operations.

COMMUNICATIONS (VOICE RELAY)

The purpose of the airborne voice relay communications system is to enhance uplink and downlink voice communications between spacecraft and ground stations via relay equipment on ARIA aircraft. In addition, voice communications can be recorded. All eight ARIA aircraft are equipped with the following capability.

AIRCRAFT

Transmissions between aircraft and spacecraft are on USB and VHF.

Frequency: USB downlink: 2287.5 and 2282.5 MHz
 USB uplink: 2106.4 and 2101.8 MHz
 VHF uplink and downlink: 296.8 MHz - simplex
Range: USB - 900 nm
 VHF - 1200 nm

Transmissions between aircraft and ground stations are HF SSB.

Frequency: Downlink: 2-30 MHz } Duplex
 Uplink: 2-30 MHz }
Range: Approximately 5,000 nm
Teletype: Frequency-shift-keyed doppler corrected capability
 between ground station and aircraft occurs at HF SSB.
 Downlink: 2-30 MHz } Duplex or simplex
 Uplink: 2-30 MHz }

Equipment consists of:

Antennas: 2 HF wing probes
 1 HF trailing wire
 4 VHF crossed dipoles (mounted in telemetry dish)
 1 S-band (telemetry dish)

Transmitters: 3 HF (2-30 MHz), 1 kw
 1 VHF (296.8 MHz) 100 w
 1 S-band (2106.4 MHz) 100 w

Receivers: 3 HF (2-30 MHz)
 1 VHF (296.8 MHz)
 2 S-band (2287.5 MHz)

AIRCRAFT

RANGE INSTRUMENTATION CHECKOUT

Aircraft beacons and simulator installations are primarily used to check out various ship and ground-based missile tracking equipment. For example, if a light on the aircraft is used in conjunction with ballistic cameras on the ground, then the aircraft position may be accurately determined optically. The accuracy of the radar tracking equipment may then be determined by comparing the radar data with the known accurate optical fix.

Additional uses of beacons and simulators include vectoring of an aircraft to a desired position for other test purposes, testing of antennas designed for use on missiles, and simulations of manned or unmanned spacecraft.

The airborne beacons most commonly used on the ETR are as follows:

DPN-66 (C-Band) Beacon

Receiver:

Frequency: 5395-5905 MHz
Sensitivity: -70 dbm
Codes: 4 plus signal pulse

Transmitter:

Frequency: 5400-5900 MHz
Peak power: 500 watts
Power input: 28 vdc at 1.9 amp

APW-11 (S-Band) Beacon

Receiver:

Frequency: 2680-2920 MHz
Sensitivity: -45 dbm

Transmitter:

Frequency: 2700-2950 MHz
Peak power: 137 watts

TABLE IV -A
NAVIGATION EQUIPMENT-ARIA

Description	EC-135N (8 ea)
TACAN	2
ADF	2
VOR	1
Loran A	APN-70
Weather radar (X)	APN-59
Doppler Nav. and computer	APN-147/ASN-35
Absolute altimeter	SCR-718
Sextant (periscopic)	1
Magnetic compass	N-1 J-4
VLF hyperbolic nav.	Omega

TABLE V
ARIA TELEMETRY SYSTEM

Description	EC-135N (8 ea)
<u>System Noise Temp.</u>	
S-band	900° K
L-band	2600° K
P-band	1300° K
<u>Antennas</u>	
S-band	83 in. dish
Tracking	RHC/LHC
Fixed	AT 256 (data transfer)
L-band	83 in. dish
Tracking	RHC/LHC
Fixed	---
P-band	
Tracking	4 cross dipoles
Fixed	RHC/LHC/linear
	AT 256 linear (data dump)
<u>Preamps/Multicouplers</u>	
S-band	narrow band
L-band	2200-2300 MHz
P-band	wide band..
	1435-2300 MHz
	225-2600 MHz
<u>Receivers</u>	
Tracking	4 ea MR 109
Single Channel	7 ea
Dual Sum/Diff.	TR-109
Data	---
Dual Channel	10, 30, 50, 100, 300, 500,
Pol. Diversity	750, 1500, 3300 kHz
Single Channel	
IF Bandwidth	
Selectable	

TELEMETRY SYSTEMS (CONTD)

AIRCRAFT

Description	EC-135N (8 ea)
<u>Combiners - Post D</u> Space Diversity Freq. Diversity Polarization	--- --- ---
<u>Combiners - Pre-D</u> Space Diversity Freq. Diversity Polarization	--- --- TR-109
<u>Recorders - Mag. Wide Band</u> 7 Channel each Direct No/B.W. FM No/B.W. 14 Channel each Direct No/B. W. FM No/B. W.	--- --- --- 2 ea Mincom Mod 28 24/400-1.5 MHz 4/0-500 kHz
<u>Data Insertion Converters</u> IRIG Proportional B. W. Constant B. W. AIA	2 ea DIC 1A --- ---
<u>Data Sep. Discriminators</u> Fixed Tunable	*6 ch. IRIG 1-18 A-E (EMR 210) 1 ea IRIG band switching *1 ch (EMR 229) 300-300 kHz
<u>Data Displays</u> Oscillograph Rcdr Direct Write Rcdr	*1 ea 8 in. chart H. W. 1100 ---

* ARIA 330 and 375 only

TABLE VI
RANGE INSTRUMENTATION CHECKOUT-ARIA

Description	EC-135N (8 ea)
Beacons*	1 A/C only
C-band	DPN-66
Glotrack types G&C	Glotrack types G&C
Mistram	---
S-band	---
*Note: These items installed on a limited bases as needed.	
Simulators	
Unified S-band	---
Sig Gen	---
S-band xmtr	0.5w PM/FM
P-band xmtr	0.5w FM

TABLE VII
DATA PICKUP - ARIA

Description	EC-135N (8 ea)
Retransmission to ships and ground stations	
S-band	yes
L-band	yes
P-band	yes
SEARCH (ELECTRONIC)	
Beacons	P and S-band

TABLE VII
TIMING SYSTEMS-ARIA

Description	EC-135N (8 ea)
<u>Time Signal Gen</u> IRIG Codes AMR Codes NASA Codes Rep rates	Dual Astrodata A, B, C, D, E B-1, D-1 36 bit, 28 bit serial 100K pps OT* to 1 pph OT*
<u>Freq. Standard</u> Crystal Atomic	1 ea 1x10 ⁻⁹ 1 ea 1x10 ⁻¹¹
<u>Battery Backup</u>	yes
<u>Synchronization</u>	
WWV Using portable clock	5 msec 500 msec
<u>Count Down Generator</u> (Ground Elapsed Time-Get)	1 ea
<u>Displays</u> GMT GET	8 7

*OT- On Time

TABLE IX
COMMUNICATIONS SYSTEMS

Description	EC-135N (8 ea)
<u>Standard A/C Equipment</u>	
HF	(2) 618 T-2
Antenna VHF	Fin probe (F.P.) (2) AN/ARC-VHP-101
Antenna UHF	(2) Stub
Antenna	(2) ARC-34 (2) AT-256
<u>Special Equipment</u>	
HF SSB	3 ea. 2-30 MHz /duplex
Antenna	(1) trailing wire
VHF (up link (down link	(2) wing probes 296.8 MHz
Ant (up link (down link	simplex TLM TRK dish at 296.8 MHz
USB (up link (down link	2106.4 MHz 2101.8 MHz 2287.5 MHz 2282.5 MHz
Antenna Teletype	TLM trk dish FSK on FCC-3 HF SSB
Printer Tape Perf Tape Read	2 each 1 each 1 each

AIRBORNE ASTROGRAPHIC CAMERA SYSTEM (AACS)

The AACS System consists of two matched aircraft which collect data to determine precise relative and earth coordinate spatial positions of luminous re-entry objects. The position of the objects is determined by photographing them against a star field background. The star and camera position enables determination of the relative and absolute position of the objects.

The earth coordinates of the aircraft are determined from the Distance Measurement Equipment (DME) and altimeter data recorded during the data interval. The air to air DME measures the distance between the two aircrafts. The air to ground DME link provides range data between each aircraft and a precisely surveyed DME ground station site. The aircraft radio altimeter provides altitude data. This data can be reduced to find the X, Y, and Z coordinates of each aircraft (and its cameras) relative to the ground station site. The spatial location of the re-entry objects trajectories relative to a star field background is shown on each of the 16 camera film plates. Knowing the precise geographical coordinates of the two aircraft and spherical coordinates of the individual stars in the star field recorded on the films it is possible by data reduction processes to create an accurate re-entry trajectory of each object.

The prime mission electronic equipment (PMEE) consists of:

1. 16 cameras and associated control equipment
2. Recording equipment
3. Timing equipment
4. Special distance measuring equipment (DME)
5. Modified Radar Altimeters

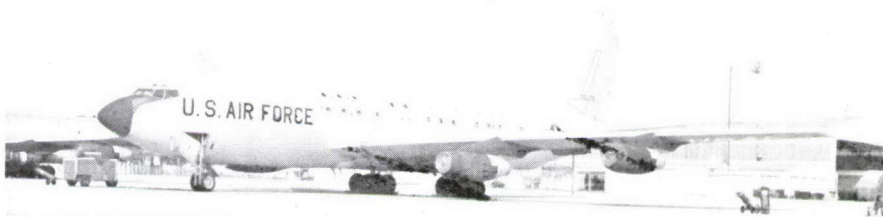

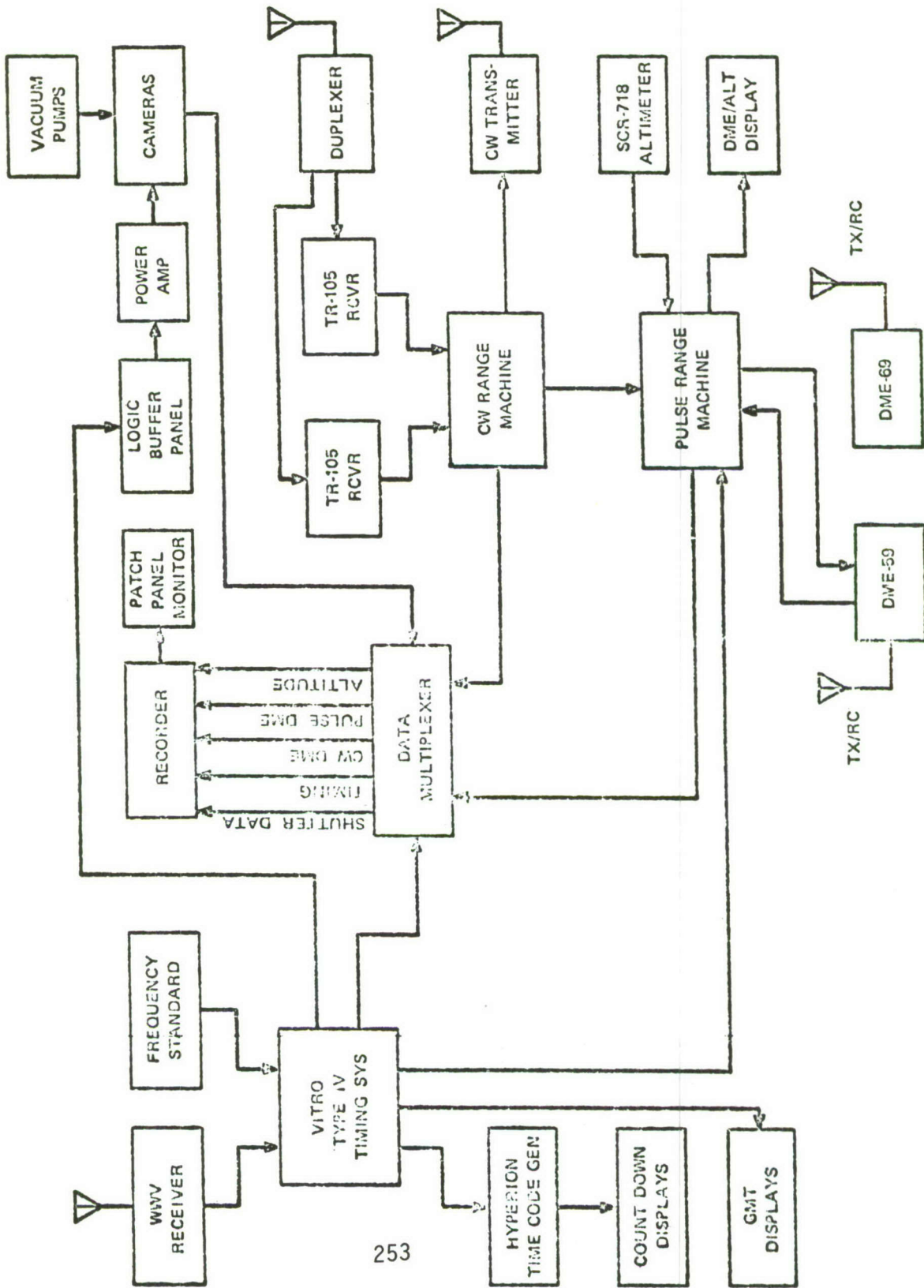

253

FIG 50 AACs SYSTEM

TIMING

The AACS timing equipment and functions are summarized in Table X below:

Timing Subsystem

<u>Equipment</u>	<u>Qty</u>
Vitro Type IV Timing Unit	1
Time Signal Generator (Model 2691)	
Generator Power Supply (Model 2697)	
Distribution Panel (Model 2699)	
Patch Panel (Model 2702)	
WWV Receiver (Specific Products WVTR)	1
Logic Buffer Panel (Vitro Model 10913)	1
Remote Time Display Unit (Model 2700)	1
Hyperion Time Signal Generator (Model HI-140-862)	1
Portable Clock (Austron Model 1210-H)	1
Test Equipment	
Oscilloscope (Fairchild Model 765)	2

The Timing Subsystem supplies:

- a. Selected pulse repetition rates to the DME subsystems
- b. Special pulse sequences to Camera Control subsystem
- c. Greenwich Mean Time (GMT) in the form of IRIG B1 code to the Recording subsystem.
- d. Mission Elapsed time also in the form of IRIG B1 to the Recording subsystem
- e. Parallel coded GMT for displays in the Timing/Record console, Vitro Type IV Unit, and the Mission Control console.
- f. Parallel coded Mission Elapsed Time for displays in the Timing/Record console and Mission Control console.

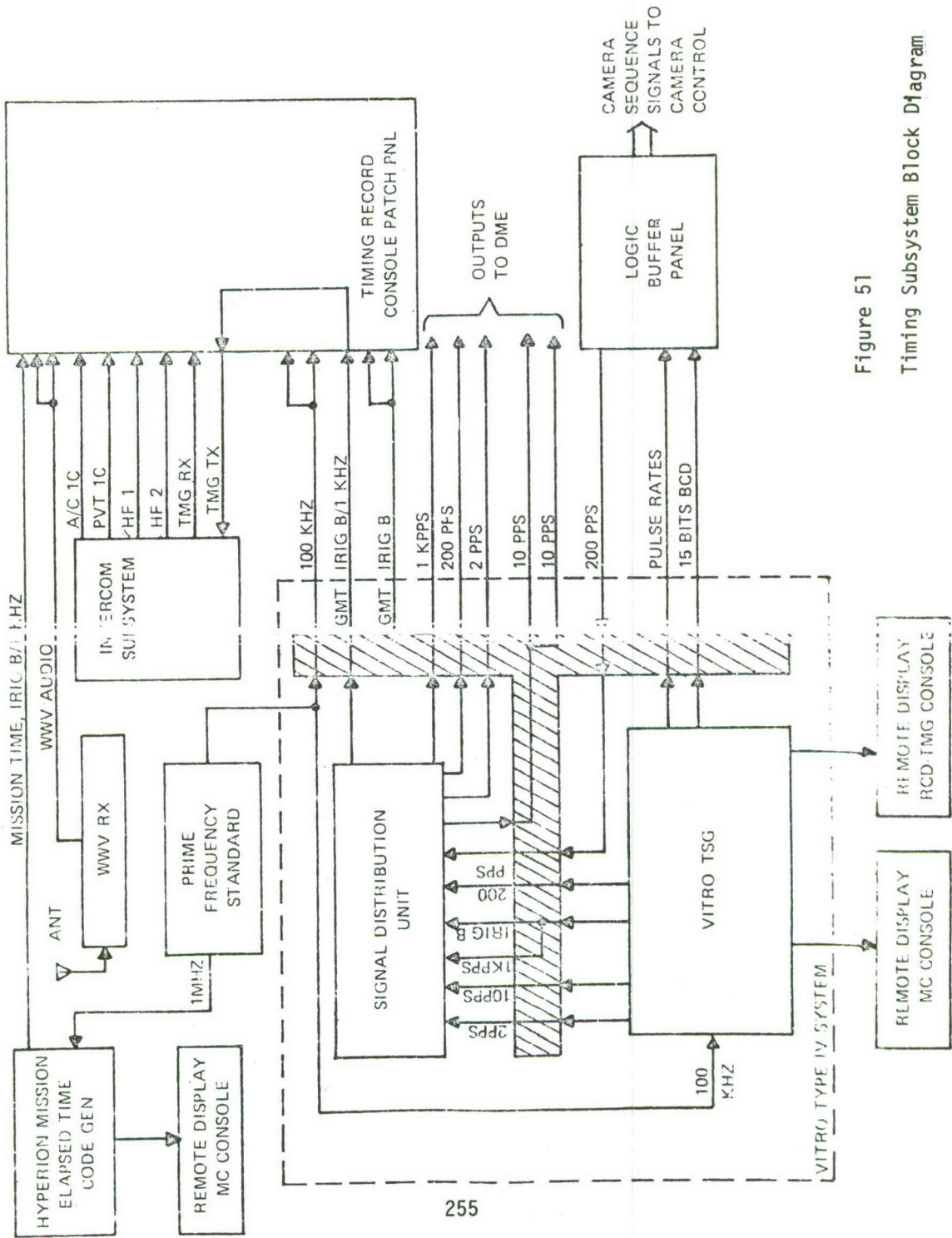

Figure 51

Timing Subsystem Block Diagram

DISTANCE MEASUREING EQUIPMENT SUBSYSTEM (DME)

The DME subsystem provides data needed to accurately locate the AACS systems in space relative to a known point on the earth's surface. Two ground stations are required for absolute fixes. It consists of three separate measuring systems:

1. CW DME
2. Pulse DME
3. SCR718 Radar Altimeter

Figure 52 is a block diagram of the DME subsystems. Figure 53 shows the DME system in a mission support configuration.

CW-DEM Subsystem (Air-to-Ground Link)

The CW-DME range measurement technique is based on the phase comparison of a set of continuous wave frequencies or "tones" transmitted from an aircraft station to a ground station and back to an aircraft station by means of frequency modulation applied to an rf carrier operating in the vhf telemetry band (P-band).

Each airborne station consists of the following equipment:

<u>Equipment</u>	<u>Quantity</u>
CW Range Unit (AFETR)	1
Transmitter (Dorset TR 501-A)	1
Power Amp (Dorset A801-A)	1
Receivers (ACL TR105)	2
Diplexer (AFETR)	1
Antennas (AT 256)	2
Display Unit (AFETR)	1

Each ground station comprises the following equipment:

Duplexer (AFETR)	1
Receivers (Space Gen RTD-500)	2
Video Amplifier (Space Gen VR-005)	1
VHF-FM Transmitter (AFETR)	1
Spectrum Display Unit (Vitro 5DV-401)	1
Counter (HP 5326B)	1
Antennas (AFETR/AT256)	2

Pulse-DME Subsystem (Air-to-Air Link)

The Pulse-DME range measurement technique uses the radar-transponder principle. A short burst (or pulse) of high-frequency electromagnetic energy is transmitted from one aircraft toward the second aircraft; the energy is received by the transponder in the second aircraft and a return pulse is generated directed toward the first aircraft but at a different frequency. This pulse is received and detected in the first aircraft. The time between initial transmission and reception of the reply is carefully measured and, knowing the index of refraction for the path, the product of velocity and time is calculated to obtain distance measurements. In this particular case the frequencies used are 9310 and 9375 Mhz (X-band).

Each airborne pulse DME system consists of:

<u>Equipment</u>	<u>Quantity</u>
DME 59 (modified APN 59)	1
DME 69 (modified APN 69)	1
Scientific Atlanta Horn Antenna	2
Pulse Range Unit (AFETR)	1
Digital Display	Shared with CW-DME

MISSION CONTROL

The Mission Control console is the control center for the operation of the instrumentation system. The Mission Coordinator directs the activities of the PMEE operator and has direct control of the operation of the cameras, recorder, and DME.

PMEE COMMUNICATIONS

A separate interphone system is provided for the PMEE area. This system is interfaced with the aircraft interphone system and provides the following communication capability:

<u>Switch Position</u>	<u>Monitor</u>	<u>Select (Talk/Transmit)</u>
1	Aircraft Interphone	UHF-2
2	PMEE (PUT) Interphone	VHF-1
3	HF-1	VHF-2
4	HF-2	HF-1
5	UHF-1	HF-2
6	VHF-2	PMEE (PVT) Interphone*
7	VHF-1	Aircraft Interphone
8	UHF-2	—

*Includes voice annotate on recorder

PMEE Interphone Stations are provided as follows:

	<u>Station</u>
Mission Control Console	1
Timing/Record Console	2
Camera Control Console	3
Camera Area No. 1	4
Camera Area No. 2	5
Crew Rest Area No. 1	6
Crew Rest Area No. 2	7

NAVIGATION SYSTEM

The AACS Aircraft have the following instrumentation which is used by the navigator:

<u>Item</u>	<u>A/C 135</u>	<u>A/C 376</u>
1. UHF Nav Sys	ARN-21	Tacan
2. VOR	X	X
3. ADF Radio	ARN-6	DFA-70
4. APN-70 LORAN		x
5. N-1 Compass System	X	X
6. True Air Speed Ind Sys	X	X
7. APN-59 Search Radar	X	X
8. Doppler Nav Radar	APN-82	APN-147
9. ASN-35 Course Computer		X
10. Periscope Sextant	X	X

The navigator has capability to navigate to the test support area where he can use the CW DME to accurately position the aircraft at ranges up to 200 nm range from the ground CW DME stations. Using the CW DME information the navigator can locate his position within 6000 ft CE.

SYSTEM ACCURACIES

Recorder Subsystem

Recorder (Mincom M-40)

Tape:	1/2 in. E. oxide
Number of Tracks:	Seven, IRIG compatible
Type Recording:	Direct
Recording Speed:	60 ips
Playback Speed:	60 ips
Record Time:	20 min. max (14 in. reel, 9200 ft. tape)
Tape Speed Accuracy:	$\pm 0.2\%$
Frequency Response:	<u>Speed</u> <u>Freq. Response (+ 3 db)</u> 60 ips 400 Hz - 250 kHz
Wideband Signal-to-Noise:	30 db unfiltered (at 60 ips)
Flutter:	Less than 0.2% peak-to-peak measuring all components from dc to 10,000 Hz at 60 and 120 ips.
Dynamic Skew:	Less than ± 0.3 microsec measured on two adjacent tracks in the same head stack at 120 ips.
Harmonic Distortion:	2.5% or less of any fundamental within rated bandpass.
Third Harmonic Distortion:	1% of any fundamental within rated bandpass.

Data Insertion Converter (DEI DIC-1B)

The DIC is used to combine up to 18 independent locally generated data channels into a single output. Its major electrical characteristics are:

VCOs*	IRIG bands 1 through 18 and A through E
Linearity:	0.2% of bandwidth
Stability:	0.5% of bandwidth drift/12 hours
Incidental AM:	1 db
Sensitivity:	5.0 V for full scale deflection

*One direct input module is provided.

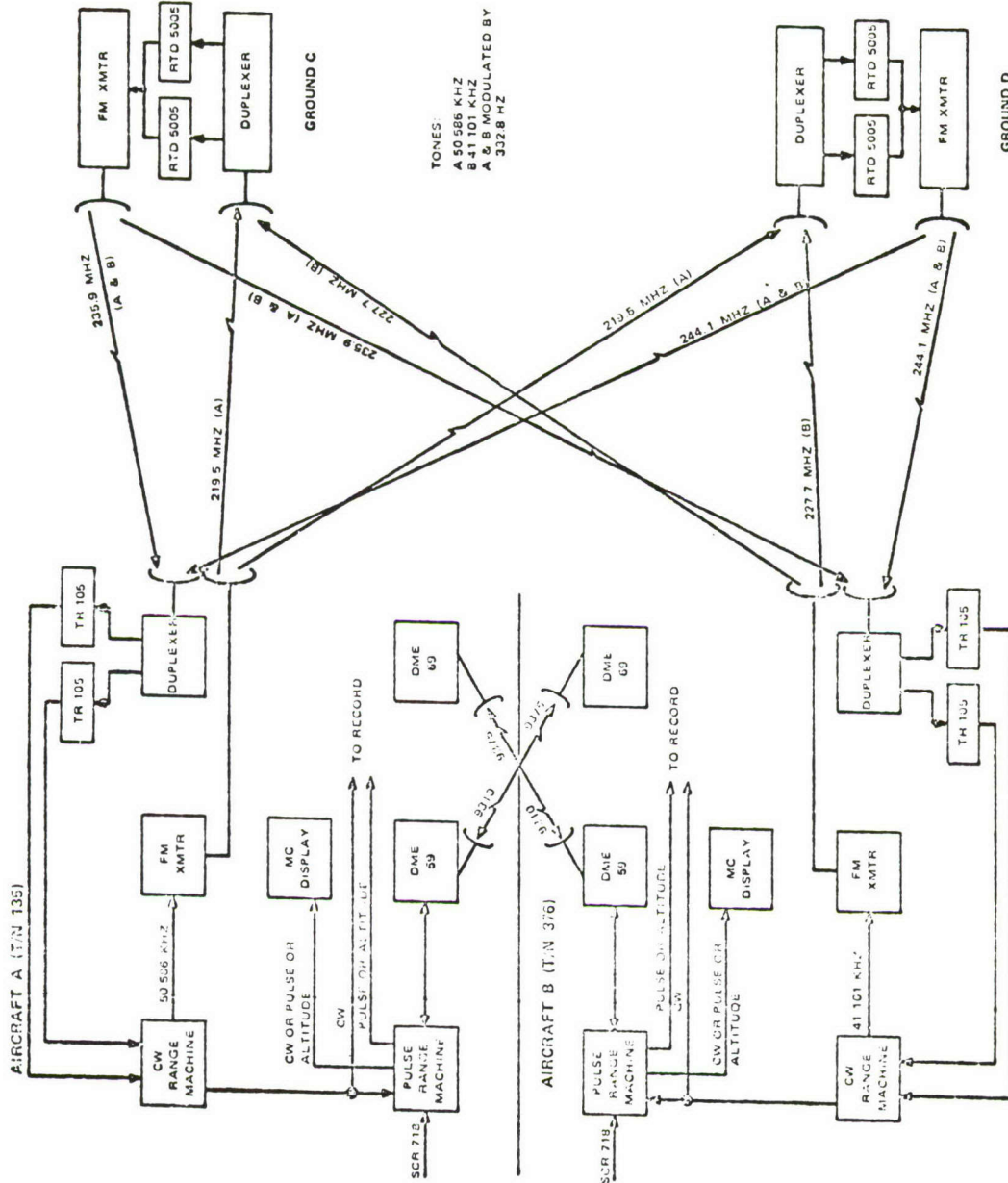

DME SUESYSTEM

FIG 52

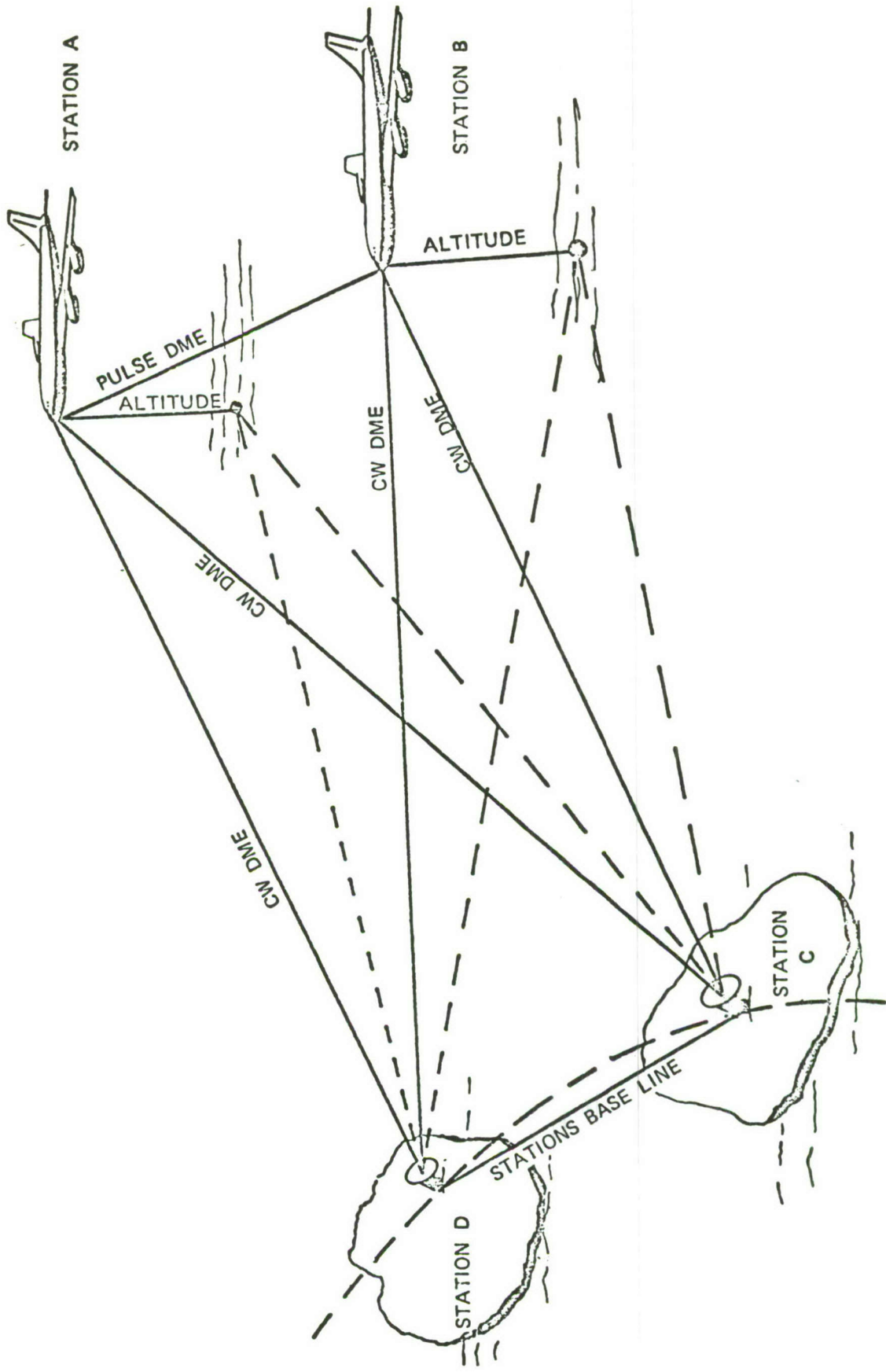

FIG 53 AACCS Mission Support Geometry

TERMINAL RADIATION PROGRAM AIRCRAFT (TRAP)

The TRAP is part of the Advanced Ballistic Reentry Systems (ABRES) program conducted by the Deputy for Reentry Systems, SAMSO (SMY). The primary purpose of TRAP is the acquisition, reduction and analysis of optical data in the ultraviolet, visible, and infrared portions of the spectrum for the evaluation of R&D reentry experiments.

The program uses two instrumented aircraft, TRAP 1 and TRAP 7. The operation, maintenance, and upgrading of TRAP instrumentation and the reduction, interpretation, and analysis of TRAP data is managed by SAMSO, Norton AFB, CA. The primary contractor for SAMSO is Avco Research Laboratory.

INSTRUMENTATION

Tracking instruments are mounted on both manual and gimbal pedestals which use remote acquisition sight and automatic tracking.

Mission Support and complete systems descriptions can be obtained through SAMSO (SMYBW), TRAP Program Office, Space and Missile Systems Organization, Air Force Systems Command, Norton Air Force Base, CA 92409.



VI
ETR STATIONS

ETR STATIONS

ETR STATIONS

<u>Station or Site Number</u>	<u>Location</u>
	Florida Annexes
Station 1	Cape Kennedy Air Force Station
Station 3	Grand Bahama Island
	Bahama Cays Sites
Station 4	Eleuthera Island (US Naval Facility)
Station 5	San Salvador Island (deactivated)
Station 6	Mayaguana Island (deactivated)
Station 7	Grand Turk Island
Station 9.1	Antigua Island
Site 40	Trinidad Island (deactivated 1 Oct 71)
Station 11	Fernando de Noronha (deactivated)
Station 12	Ascension Island
Station 13	Pretoria, Republic of South Africa
Station 89	Mahe

Brief descriptions of the above stations and sites follow. More detailed information on topography, climate, real property, roads, and utilities may be obtained from the Base Master Plan for each station.

ETR STATIONS

FLORIDA ANNEXES

The Florida Annexes are mainland instrumentation sites ranging from New Smyrna Beach on the north to Miami Beach on the south, and from the Atlantic Ocean on the east to about 50 miles inland. The sites include an area of about 1,362 acres. The figures vary as new sites are activated and obsolete ones deactivated.

The Florida Annexes support Cape Kennedy missile and space vehicle launch operations by providing trajectory data, calibration of instrumentation systems, meteorological data, communications relay, and such information as: 1) precision radar tracking data, 2) optical data (metric and engineering sequential), 3) electronic ship positioning (LORAC), and 4) meteorological data.

Bithlo	1 Sparsa Installation	Deactivated
Cocoa Beach	1 Roti	1 Timing Set
	1 Cinetheodolite (KTH 53)	
Fellsmere	1 MISTRAM Transponder	Deactivated
Jupiter	1 LORAC End Station	
	1 LORAN C Receiver	1 Meteorological Equipment
	2 Ballistic Camera Pads	1 Sub-cable Terminal Station
	1 Timing Set	
Malbar	Comm. Transmitter Sta.	1 Timing Set
Melbourne Beach	1 Roti	
	2 Ballistic Camera Pads	
	1 Timing Set	
Miami Beach	1 MISTRAM Rate Station	Deactivated
	1 UDOP	
Patrick AFB	1 AN/FPQ-6 Radar	1 Timing Set
	1 IGOR, 1 Mobile IGOR	
	1 Mobile Askania	
	3 Ballistic Camera Pads	
Ponce de Leon	1 Sparsa Installation	IGOR Trailer Pad
Valkaria		1 Timing Set
	Meteorological Equipment	1 Sparsa Installation
Vero Beach	1 Roti	1 Ballistic Camera Platform (deactivated)
	3 Ballistic Camera Pads	
	1 Timing Set	



FIGURE 54 FLORIDA ANNEXES

CAPE KENNEDY AIR FORCE STATION 1

Cape Kennedy covers 15,430 acres on the east coast of Florida, 14 miles north of Patrick AFB. The land is level and elevations over 10 ft are rare. The annual rainfall is approximately 47 in. , with temperatures averaging 60.0 deg F in the winter and 80.7 deg F in the summer.

Within its boundaries are complete facilities for ballistic and space vehicle assembly and launch, fuel and oxidizer storage and dispensing, maintenance, administration, engineering and test labs, instrumentation and communications, range safety, and sectionalized security protection.

The Cape consists of three basic operational areas: launch areas for aerospace vehicles, the industrial area, and Port Canaveral. It is being expanded or modified to meet future range user needs on programs involving larger and more complex launch vehicles, astronautic systems, manned space stations, lunar bases, and outer space probes.

Cape Kennedy is the launch site and flight control center for aerospace programs assigned to the ETR. Data from all the ETR instrumentation sites is collected, displayed, and analyzed here. This data includes radar coverage for technical and range safety purposes, electronic velocity and position data, impact predictions, optical metric, sequential and documentary data, electronic ships positioning, surface and upper air weather data, optical and electronic tracking for range safety, telemetry receiving and recording, and command and destruct control.

- LEGEND**
- △ ELECTRONIC TRACKING (CONT. WAVE)
 - ▽ ELECTRONIC TRACKING (PULSE)
 - Y TELEMETRY
 - ⊞ COMMAND CONTROL
 - ▽ TIMING
 - FREQUENCY CONTROL & ANALYSIS
 - ▽ OPTICAL
 - ◁ RANGE SAFETY
 - ▷ METEOROLOGICAL
 - T MET ROCKET LAUNCHER
 - +

FIGURE 55 CAPE KENNEDY AIR FORCE STATION

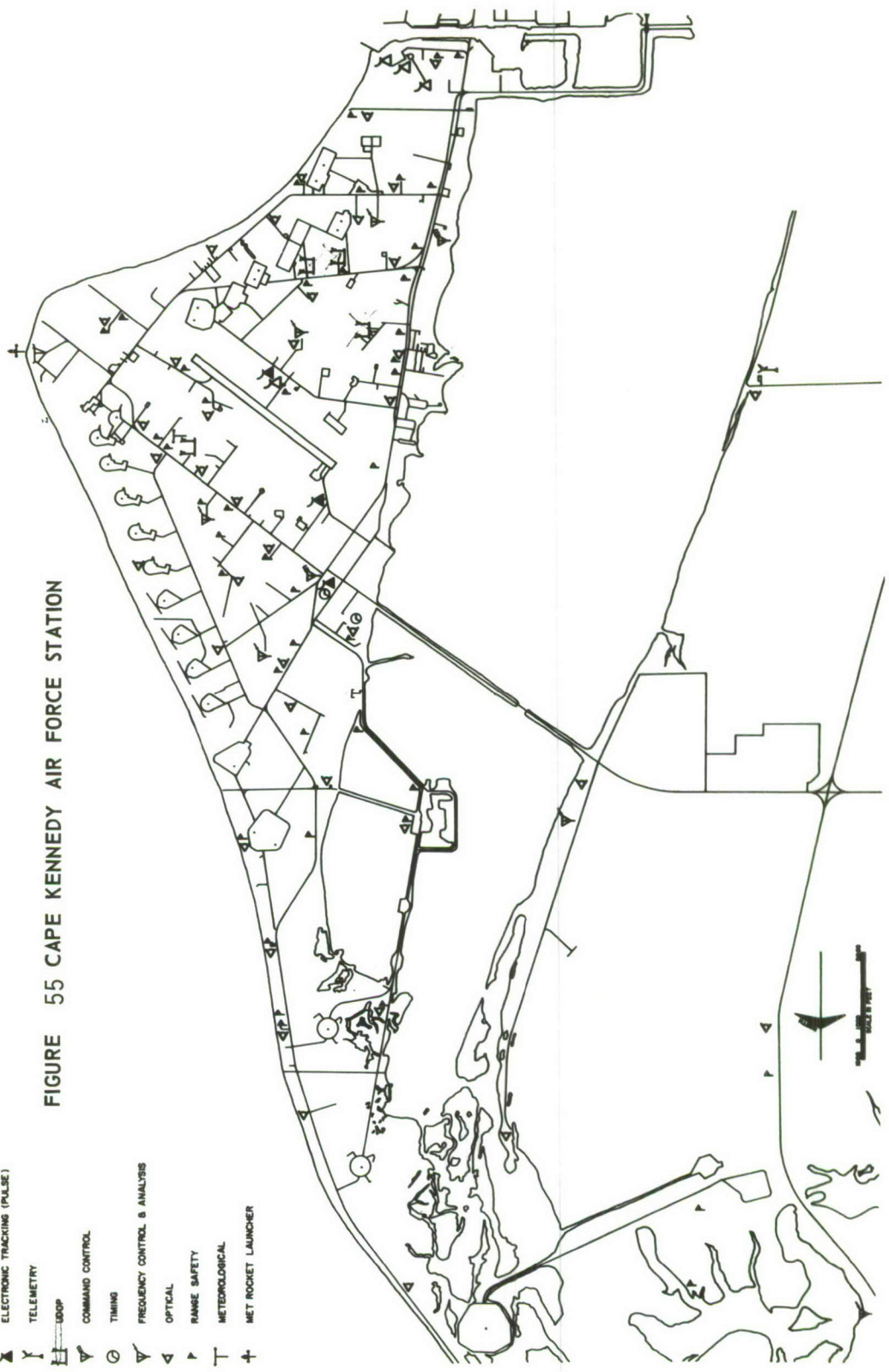

ETR STATIONS

GRAND BAHAMA, STATION 3

GENERAL INFORMATION: Grand Bahama Island (GBI) lies in the Atlantic Ocean 60 miles east of Palm Beach, FL. The main base is near the middle of the south shore. The island is 83 miles long, and averages four miles in width. The land is flat, averaging 10 to 12 ft above sea level. The Bahamian government on Grand Bahama is represented by three Resident Commissioners.

POPULATION: More than 35,000, with the majority living in the Freeport and West End areas. Over 20 small settlements and villages are scattered over the island.

CLIMATE: Rainy season, June - October; total annual rainfall, 57.5 in. Prevailing annual winds, southeast at 7 mph. Temperatures, 75 deg mean yearly; 88 deg F mean max, August; 59 deg F mean min, January.

ECONOMY: The soil is poor, covered largely with scrub vegetation. Farming is done on a very small scale. Tourism has grown tremendously in the Freeport and West End areas and is still on the increase. Freeport has a large cement plant, oil bunkering operation, and an excellent harbor.

COMMERCIAL COMM: Radiotelephone calls may be made to Nassau, the U.S., and worldwide from Freeport. There is a telephone link between the main base and the Commercial Telephone Co. in Freeport.

HOTEL AND HOUSING: Hotels are at West End and in the Freeport/Lucaya area. These resort hotels have beaches, swimming pools, game rooms, cocktail lounges, marinas, golf courses, fishing areas, and dining facilities. Freeport also has smaller hotels and motels. New hotels, apartment houses, stores, and private residences are under construction in and near Freeport. Rental units are available but are expensive.

WATER: Good quality and abundant.

AIRFIELDS: West End has an international airport and a terminal building. The Freeport International Airport has a new terminal building and an all weather runway for jet aircraft. Several airlines have frequent flight from Nassau and the U.S. mainland. They also have service from London via New York. Private aircraft use both the West End and Freeport airstrips. The ETR station has a 7,000 ft long, 200 ft wide runway. JP-4 fuel and avgas are available. ETR travel is by MAC aircraft from Patrick AFB.

OFFLOADING MARINE CARGO: A cargo pier and a boat landing ramp are available at the Gold Rock Creek Site, one mile from the main base. LSM vessels are unloaded at the pier by a 20 ton mobile crane. The ramp is used for bow loading and unloading.

ETR STATIONS

BAHAMA CAYS SITES

A series of small cays lying off Grand Bahama Island (GBI) and one site on Great Abaco Island are instrumented to acquire tracking data. These sites are administered from Station 3. Cargo is delivered to the Cays by an LCU operating from North Riding Point and the High Rock pier on GBI, by a K-boat operating from North Riding Point, and by a weekly HH53 helicopter flight from Patrick AFB.

The five sites provide the following support for aerospace vehicle tests:

- Electronic velocity and position data
- Electronic ship positioning data
- Midcourse and terminal radar coverage for technical and range safety purposes

The map opposite shows site locations of Cays instrumentation. The following information is offered for informal planning:

- 42 Little Carter Cay
- 43 Marsh Hartor
- 44 Allans Cay
- 45 Big Carter Cay
- 56 Great Stirrup Cay

TABLE XI

BAHAMA CAYS PLANNING INFORMATION

INFORMATION for Planning	SITE 42	SITE 43	SITE 44	SITE 55	SITE 56
Food Service	Pan Am		Pan Am		Trailer
ETR Beds Available	64	0	8	--	5
Other Beds	--	Hotel (40)	--		--
TRANSPORTATION (available)	HH-53 LCU K-Boat	HH-53 LCU K-Boat	HH-53 LCU K-Boat	Small boat from Site 42 LCU	HH-53 LCU
COMMUNICATIONS					
Subcable	--	--	--	--	X
AN/TRC-24 (TCC-7)	X	--	--	--	--
(TCC-3)	X	--	X	--	--
KWT-6	X	X	X	--	X
PAX-60 kHz	X	--	--	--	--
Microwave	--	--	--	--	--
Radio HF	X	--	--	--	--
VHF, A - G	X	X	X	--	X
AN/TRC-1	X	--	X	--	X

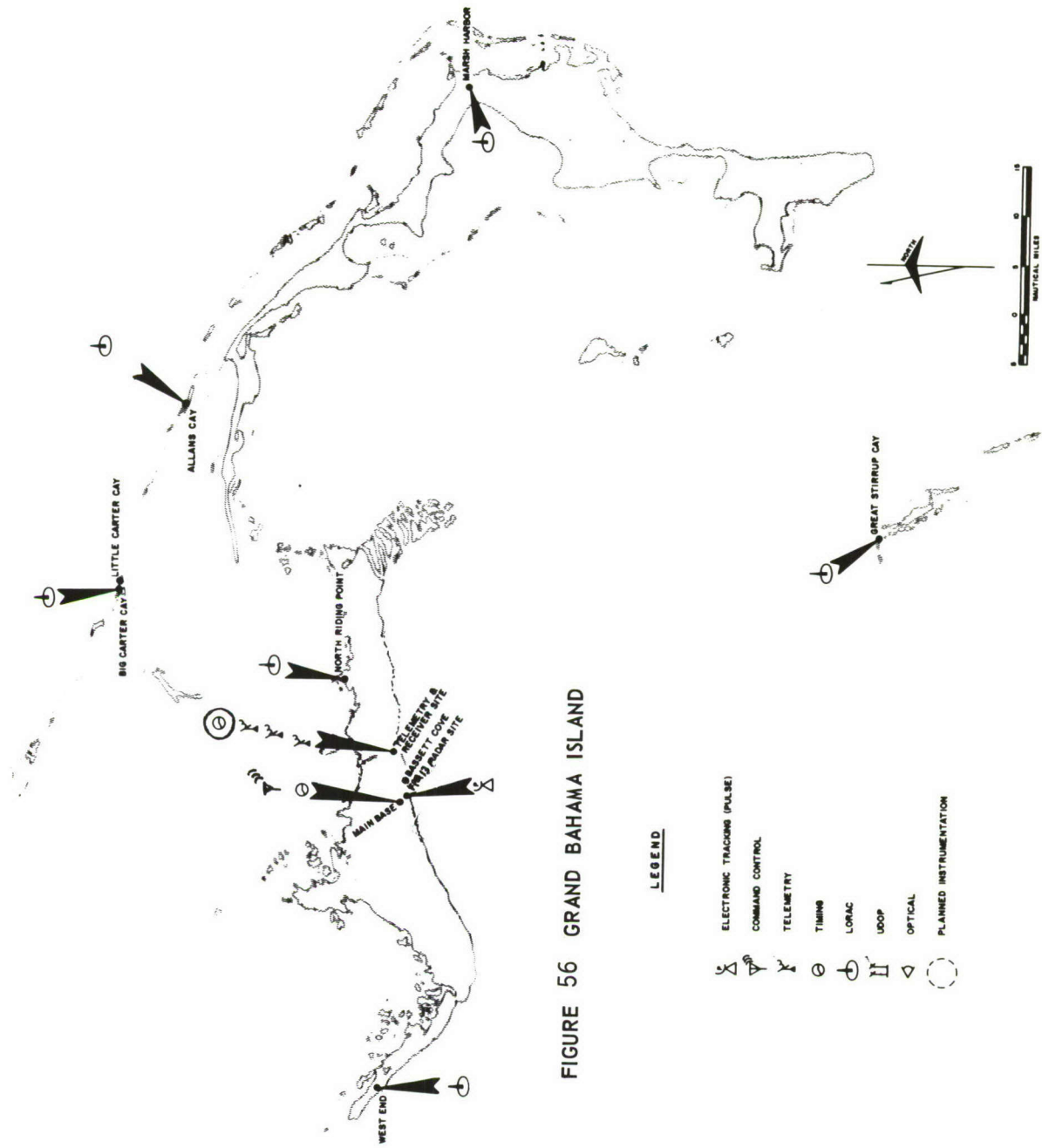

FIGURE 56 GRAND BAHAMA ISLAND

LEGEND

- ⊗ ELECTRONIC TRACKING (PULSE)
- ⊕ COMMAND CONTROL
- ⊙ TELEMETRY
- ⊖ TIMING
- ⊗ LORAC
- ⊕ LOOP
- ⊖ OPTICAL
- ⊙ PLANNED INSTRUMENTATION

ETR STATIONS

ELEUTHERA, STATION 4

GENERAL INFORMATION: This island is located 52 miles east of Nassau and covers an area of 164 sq miles. It is 122 miles long and from 1/2 to five miles wide. The rolling ground is of decomposed coral and limestone and reaches a height of 120 ft at a point in the northwest portion. The Government of the Bahamas is represented by Eleuthera's three Resident Commissioners. This station is in support of the U. S. Naval Facilities.

POPULATION: Between 7,000 and 8,000.

CLIMATE: Rainy season, May - October; total annual rainfall, 47 in. Prevailing winds, east at 12 mhp.
78 deg F mean yearly temperature.
88 deg F mean max, warmest month - August.
67 deg F min., coolest month - February.

ECONOMY: Eleuthera supplies Nassau with fresh produce, fruit, poultry, cattle, and dairy products. Farming is the chief occupation. Corn, peas, rice, fish, and conch make up the local diet.

COMMERCIAL COMM: The wireless stations are located at all settlements over 600 population such as Hatchet Bay, Governor's Harbour, Rock Sound, Upper Bogue, and the Current.

HOTELS AND HOUSING: Hotels on full American plan include French Leave (Governor's Harbour), the Rock Sound Club, the Current, the Buccaneer and Arnold Palmer. Rates vary by season. A few houses are available.

WATER: Six settlements are served with running water systems; others have shallow wells; all are contaminated to some extent. Base water is purified.

AIRFIELDS: The Rock Sound and North Eleuthera Airports are commercial airstrips on the island and have limited resources. The AFETR runway lies about eight miles northwest of Governor's Harbour. It is 23 ft above sea level and constructed of coral with asphalt sealer. The runway (6,300 x 150 ft with 500 ft over-runs) can receive loads up to C-124s. Runway lighting, glide slope indicator, control tower, homer beacon, wind socks, fire and crash equipment are available, but no aircraft servicing. AFETR air travel to Eleuthera is by MAC from Patrick AFB.

OFFLOADING MARINE CARGO: Cargo for this station is delivered in LSM type vessels at an AF pier located a mile from the main base. A crane of 20 ton capability is available. Vans and heavy wheeled equipment are offloaded through the bow doors of the LSM onto a ramp adjacent to the pier.

ETR STATIONS

GRAND TURK, STATION 7

GENERAL INFORMATION: Grand Turk Island lies about 90 miles north of the Dominican Republic and 660 miles southeast of Cape Kennedy. It is composed of coral sandstone, shaped like a rectangle (N/S), and covers an area of 9.4 square miles. Most of the island lies only a few feet above sea level.

POPULATION: 2,346

CLIMATE: Rainy season, August - November; average annual rainfall, 29.7in.
Prevailing winds, east at 15 mhp
82 deg F mean yearly temperature
88 deg F mean max, warmest month - August
71 deg F mean min, coolest month - January

ECONOMY: Agriculture is almost nonexistent because of the low rainfall. About 70 islanders are employed at the base. Come conchs and lobsters are exported. Markets and shops are limited.

COMMERCIAL COMM: Cable and Wireless, Ltd (West Indies) has worldwide cable connections by way of Barbados, Jamaica, Bermuda, and Antigua by two circuits leased from the AFETR submarine cable; radiotelephone with South Caicos, Salt Cay, and worldwide radiotelephone by way of Jamaica. Mail service: air (Nassau) and marine (Jamaica). Cockburntown has a government operated subscriber telephone service.

HOTELS AND HOUSING: There are not hotels and only one guest house on the island.

WATER: The civilian supply is by rainfall catchment. Total municipal storage is 400,000 gallons. All private homes use rain water from cisterns. The base has five distillation units with total capacity of 1,500 gph and can store 1,250,000 gallons.

AIRFIELDS: The AFETR airstrip, located within a mile of the main base, is the only landing field. Its runway, of coral/asphalt with limestone chip, is 5,043 by 150 ft with 500 ft overruns and will permit landings by C-124 and C-133 aircraft.

OFFLOADING MARINE CARGO: Cargo is delivered in LSM type vessels and is offloaded by pier positioned cranes of 20 ton rated capacity. Vans and heavy wheeled equipment are offloaded or loaded from bow doors at the LSM ramp alongside the pier.

ETR STATIONS

ANTIGUA, STATION 9.1

GENERAL INFORMATION: Pleasant and picturesque Antigua, a member of the British Commonwealth in the Leeward Islands, was named for a church in Seville. It became independent in 1967. Roughly circular (16 x 12 miles), its jagged coast lines inclose an area of 108 square miles. Formed from limestone and volcanic rock, its rolling hills reach an elevation of 1,330 ft in the southwest section. The main base, in the center of the north coast, tops a hill overlooking the bay. It is 1,250 miles southeast of Cape Kennedy.

POPULATION: 65,000 (1967 est)

CLIMATE: Rainy season, May - November; total annual rainfall, 28 in.
Prevailing winds, east northeast at 13 mhp
79 deg F mean yearly temperature
86 deg F mean max, warmest month, August
72 deg F mean min, coolest month, February

ECONOMY: The principal crops are sugar, molasses, and Sea Island cotton; but bananas, pineapples, rum, arrowroot, and castor beans are also exported. Tourist trade is the most important source of income. An oil refinery is in operation.

COMMERCIAL COMM: Cable and Wireless West Indies, Ltd offers wireless and telephone service to all parts of the world. In St. Johns, local telephone service is available to the intrabase telephone system.

HOTELS AND HOUSING: Private housing is limited and expensive, and market supplies are meager. There are many good resort hotels. 15 December - 15 April is tourist season.

WATER: Public water is not safe to drink; base water, however, is purified.

AIRFIELDS: Coolidge Airport (international), next to the base, is the only airstrip. It was built by the U. S. in 1941 and turned over to the Antiguan Government in 1949. Contract fuel and oil are available -- 115/145 octane and jet fuel. AFETR air travel to Antigua is by MAC from Patrick AFB.

OFFLOADING MARINE CARGO: Cargo is delivered in LSM type vessels and is offloaded by pier positioned cranes of 20 ton rated capacity. Vans and heavy wheeled equipment are offloaded, or loaded, through bow doors of the LSM when beached at the LSM ramp near the pier.

ETR STATIONS

ASCENSION, STATION 12

GENERAL INFORMATION: The volcanic cinder pile lies in the South Atlantic about 700 miles northwest of St. Helena about 5,100 miles downrange. It has been a British colonial possession since 1501 and is governed from St. Helena through a resident Administrator. Small, volcanic, and hilly, the island's 34 square miles form a rough circle less than seven miles in diameter. The main base occupies the southwest part.

POPULATION: About 1700. About one-third are St. Helenians of Portuguese/East Indian descent; the rest are British, employed by Cable and Wireless, Ltd., the British Broadcasting Company, Ministry of Public Building and Works, and South Atlantic Cable Company.

CLIMATE: Rainy season, March - September; total annual rainfall, 5 in. Prevailing winds, southeast at 17 mhp. 77 deg F mean yearly temperature. 87 deg F mean max, warmest month, March - April. 68 deg F mean min, coolest month, September.

ECONOMY: The local income is based on the British and United States installations. Green Mountain (2,800 ft), which is frequently covered by clouds, is the only fertile area. Here cabbage, lettuce, beans and other vegetables, and some cattle are raised for consumption by the British residents.

COMMERCIAL COMM: The British cable station (Cable and Wireless, Ltd) connects this island with all parts of the world.

HOTELS AND HOUSING: No commercial restaurant or hotel available.

WATER: The British rely on distillation and catchment basins for supply. The base operates entirely on distilled water with an average consumption of 47,000 gallons daily. Three concrete reservoirs and one steel tank store 714,000 gallons.

AIRFIELDS: Ascension Auxiliary Airfield is the only landing field. The runway has an 8 in. subbase, 8 in. base, and a 2 in. asphaltic-concrete top course. It is 10,000 x 150 ft with a 1,000 ft overrun at the southeast end, and will sustain a loaded C-135. JP-4 and avgas are available.

OFFLOADING MARINE CARGO: Cargo vessels anchor offshore and transfer cargo (to 30 ton max in ideal weather) into barges for unloading at Georgetown's 140 x 90 ft concrete dock by 40 ton Lima crane. However, heavy seas and shock risk usually prevail and demurrage rates are high, so airlift is regularly used for items weighing under 15 tons.

- LEGEND**
- ⊗ ELECTRONIC TRACKING (PULSE)
 - ⊙ COMMAND CONTROL
 - ⊙ TELEMETRY
 - ⊙ TIMING
 - ◁ OPTICAL
 - ⊙ MET ROCKET LAUNCHER
 - ⊙ METEOROLOGICAL

FIGURE 58 ASCENSION

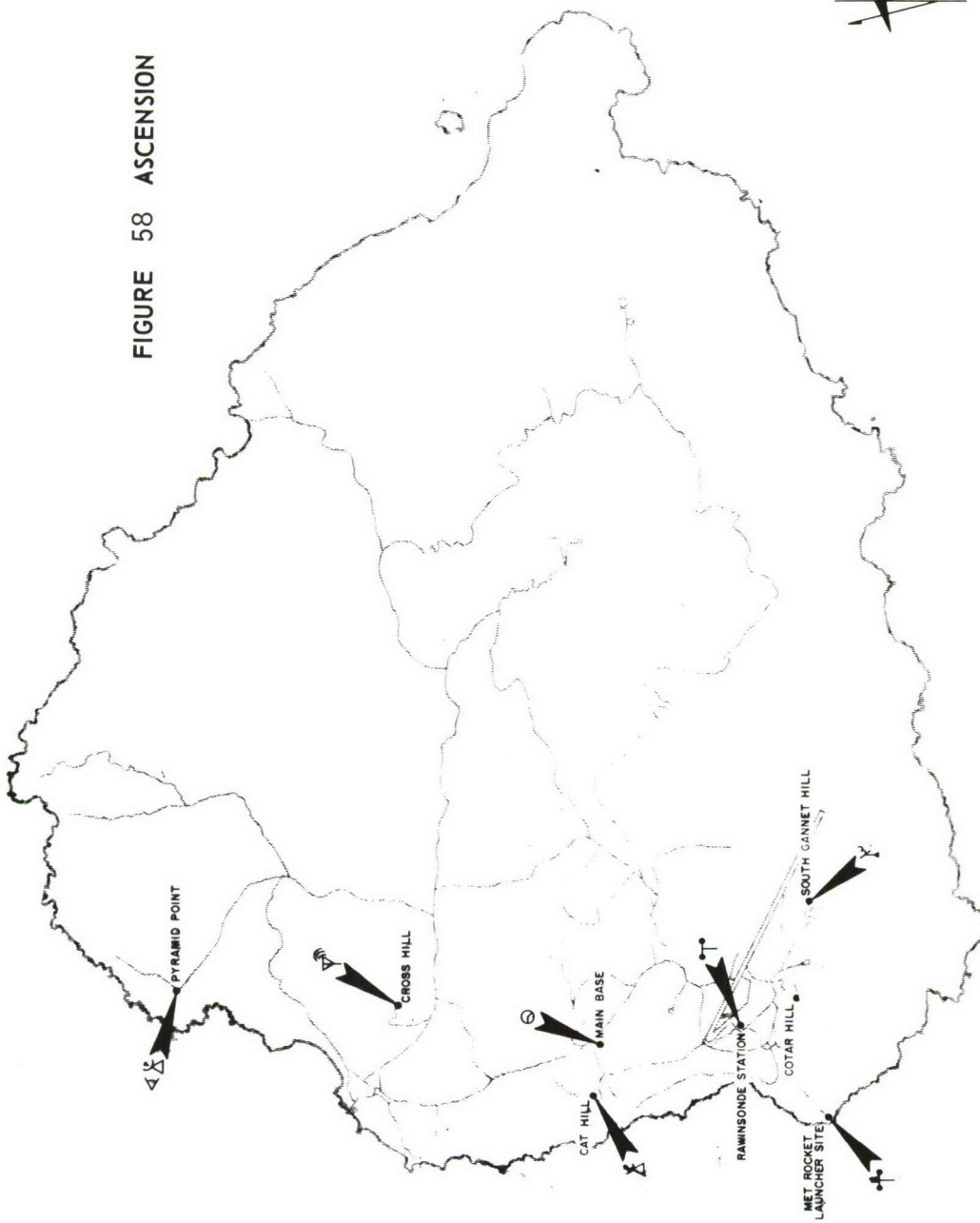

**PRETORIA
REPUBLIC OF SOUTH AFRICA
STATION 13**

GENERAL INFORMATION: AFETR's only continental downrange station is located on the Grootfontein Bombing Range of the South African Air Force, 6,915 nm from the Cape and 18 miles southeast of midtown Pretoria. This city in Transvaal Province is the Republic's fourth largest. It lies at latitude 26° S, longitude 28° E, 400 miles inland from the Indian Ocean and 5,100 ft above sea level. The whole area rests on a high plateau of rolling pasture land covered mainly with low, coarse grass and wooded areas along paths of natural drainage.

POPULATION: Pretoria has 422,500 inhabitants (1965 official estimate). Many Europeans speak both English and Afrikaans. (Pretoria is the administrative capital of the Republic; Cape Town, the legislative; and Bloemfontain, the judicial.) Johannesburg is the largest city, with over 1,150,000 residents.

CLIMATE: Rainy season, October - March; total annual rainfall, 28.3 in.

Winds: In winter, light and variable; in summer northeast, east, southeast and light, except for southwest to 45 mph during storms.

Thunderstorms: Period, October - March; frequency, about 10 per month.

63 deg F mean yearly temperature

84/61 deg F summer, mean max/min

68/39 deg F winter, mean max/min

ECONOMY: Manufacturing is the chief source of income. Mining, agriculture, trade and commerce account for the rest. Principal mineral resources are diamonds, gold, and platinum. Major crops include corn, tobacco, sugar, meat, wool, citrus fruits, and vegetables.

COMMERCIAL COMM: Worldwide service. Communication with range ships and aircraft in area is provided under contract with the Postal Department. Airmail to Patrick AFB takes five or six days.

HOTELS AND HOUSING: Houses and apartments rent for about the same as in the U.S. and are similar in style and utilities furnished. Several first-class hotels provide accommodations on European or American Plan (most of the good restaurants are in the hotels).

UTILITIES: The city water is potable. Electric current is 250 v, 50 Hz and U.S. appliances use stepdown transformers obtainable locally.

AIRFIELDS: Jan Smuts International Airport near Johannesburg (36 miles from Pretoria) is used for intercontinental as well as for local air travel from Pretoria, where there is no commercial airport. AFETR personnel travel is by MAC from Patrick AFB.

OFFLOADING MARINE CARGO: Farrell and Moore-McCormack Line vessels off-load at Durban, 450 miles from Station 13, and cargo is hauled by rail or truck.

ETR STATIONS

BERMUDA, STATION 67

GENERAL INFORMATION: Bermuda is composed of the world's northernmost group of coral islands with a total land area of approximately 21 square miles. The islands lie about 600 miles east southeast of Cape Hatteras and form a chain 22 miles long. Approximately 2.3 square miles are leased to the U. S. Government for naval and other military purposes.

POPULATION: 50,000

CLIMATE: Summer weather, May to mid-November
70 deg F. mean average monthly temperature

ECONOMY: Bermuda's main source of income is tourism. About half of the available acreage is used to produce fruit and vegetables. Major exports are drugs, essences, beauty preparations and cut flowers. Principle imports are food, clothing, alcoholic beverages, fuels and building materials.

COMMERCIAL COMM: The island is served by a private telephone company. Cables connect the island with Halifax, Nova Scotia, and through Turk's Island with Jamaica and Barbados. A coaxial telephone cable system connects with New York and Montreal.

HOTELS AND HOUSING: During the spring and summer tourist seasons, rates vary from \$9 per day for a cottage to \$30 in a luxury hotel. Rates are lower in fall and winter. Accommodations in private homes are available for \$4.50 to \$7.00.

WATER: The water is excellent to drink.

AIRFIELDS: Bermuda Naval Air Station provides two runways, 9710 x 150 ft and 5617 x 160 ft.

DOCUMENT CONTROL DATA - R & D

(Security classification of title, body of abstract and indexing annotation must be entered when the overall report is classified)

1. ORIGINATING ACTIVITY (Corporate author) AFETR Directorate of Range Engineering Patrick Air Force Base, Florida		2a. REPORT SECURITY CLASSIFICATION Unclassified	
		2b. GROUP N/A	
3. REPORT TITLE AFETR Instrumentation Handbook			
4. DESCRIPTIVE NOTES (Type of report and inclusive dates) Technical Report			
5. AUTHOR(S) (First name, middle initial, last name) Directorate of Range Engineering Instrumentation Division Maintenance Management & Control Branch			
6. REPORT DATE September 1971		7a. TOTAL NO. OF PAGES	7b. NO. OF REFS N/A
8a. CONTRACT OR GRANT NO. N/A		9a. ORIGINATOR'S REPORT NUMBER(S) N/A	
b. PROJECT NO.		9b. OTHER REPORT NO(S) (Any other numbers that may be assigned this report) ETR - TR - 71-5	
c.			
d.			
10. DISTRIBUTION STATEMENT Approved for Public Release; Distribution Unlimited			
11. SUPPLEMENTARY NOTES		12. SPONSORING MILITARY ACTIVITY Director of Range Engineering Air Force Eastern Test Range Patrick Air Force Base, Florida	
13. ABSTRACT This handbook describes ETR instrumentation used to obtain data from missile and space flight tests. The Data Acquisition Section covers instrumentation for observing flight performance, receiving telemetered data, and measuring flight paths. Motion picture cameras & tracking telescopes provide optical and related coverage. Telemetry receiving stations collect and separate data. Trajectory measurement systems determine position and velocity during flight. Underwater sound systems locate missile impact. The Support Section describes equipment used to sequence prelaunch operations, control range instrumentation, and identify times of events. Equipment which formats data for use during flight and equipment for sending messages between range stations is described as well as instrumentation for collecting weather data and for detecting and locating radio interference. Computers, data converters, and photo readers and recorders used in data processing are also discussed. The Range Safety Section describes equipment used to monitor the Range area before launch, to observe deviations from planned flight paths, and to terminate a flight when required. Applicable data acquisition and support equipment are used with range safety equipment as a combined system. Viewing devices at Cape Kennedy show flight performance and instantaneous predictions of impact point. The Ships and Aircraft Section identifies the data acquisition support instrumentation installed on various types of range ships and aircraft. The ETR Stations Section summarizes the on site instrumentation resources and chief features of mainland and downrange bases.			

14. KEY WORDS	LINK A		LINK B		LINK C	
	ROLE	WT	ROLE	WT	ROLE	WT
Guided Missile Tracking Systems Rocket Trajectories Guided Missile Ranges Radar Tracking Optical Tracking Telemeter Systems Communications Systems Safety Data Processing Systems Acoustic Detectors Radiation Measurement Systems						

SUMMARY OF RANGE INSTRUMENTATION
TABLE XII

STATION	TRACKING		TELEMETRY						COMMAND				DATA HANDLING - TRANSMISSION			SHIP POSITION										
	RADAR	OPTICS	ANTENNAS	COMPUTERS	RECEIVERS	TDM	DISCRIMINATORS	TUMBLE	FIXED	MAGNETIC	GRAPHIC	RTDS	ENCODERS	TRANSMITTERS	RECEIVERS	RECORDERS	ANTENNAS	TIMING	COMPUTER	MODEM/DEMODULATOR	SYSTEM	LOCAL COORD.	IMPACT	LOMAC	NAVIGATION	
ALLANS ISL TRK STA - 44 ALLANS CAY - 45 ISL BAH																										
ANTIGUA MSL TRK STA - 9.1 ANTIGUA LEeward ISL	ANFPQ-6	BC-4	1-TAA-3A 1-TAA-3B 1-TAA-3A		2-5005 2-5008.1 35-TMR-15	1-TDM1 TEST 2-TDM1-1 1-TDM1	10-EMR 229A 35-EMR 210A	5-AMR 1400 2-MINCOM RCDF	5-OSCILG MH-1612 6-PEN MK200		1-SPAC (2DSSB) 1-DATA MODULATOR (HONEYWELL)	1-KY-171 1-D/R CMD SET	2-ANFRW-2 2-2400	2-5031-TH 2-2400	2-ANFRW-3 1-ANFRW-3	1-OSCILG MK200	1-STERLING 10 KW 1-CONICAL UNIFOLE 1-STEERABLE TEMEC	CENTRAL TMS SYS TMS TERM SYS VHF DISTRIB SYS	ANVYK-1	(M)DH-69(200BPS) (M)DH-71(400BPS) (M)TEB2-E-1(1000BPS) (D)1000R(400BPS)	RATAC	A. E. SYNCHRO	BOA HYDROPHONES MILS DATA RCDFS			
ASCENSION MSL TRK STA - 12 ASCENSION ISL	ANFPQ-16 TTR		1-TAA-3A 1-LOG PERIODIC 1-TRI HELIX	1-1200*	1-5005 2-5008.1 24-TMR-15	1-TDM1 TEST 2-TDM1-1 1-TDM1	36-EMR 210A	4-AMR 1400	4-OSCILG MH-1612 4-PEN MK200	1-SPAC (3DSSB)	1-KY-171	1-ANFRW-2 1-2400		1-ANFRW-3			1-STEERABLE HELIX TEMEC	CENTRAL TMS SYS TMS TERM SYS VHF DISTRIB SYS	MODEL 1206 TYPE 1376	OFF CABLE	X, Y, Z, 480 TONE BURST	BOA HYDROPHONES MILS DATA RCDFS				
BARBADOS BOA STA WINDWARD ISLANDS																										
BASETT COVE COMM SITE GRAND BAHAMA ISL																										
BERMUDA BOA STA BERMUDA NAVAL STA																										
BERMUDA MSL TRK STA - 67 BERMUDA ISL	ANFPQ-16 ANFPQ-6																									
BROAD OCEAN AREA ATLANTIC OCEAN LOC 81																										
CAPE KENNEDY LAUNCH AREA STA - 01 FLORIDA	ANFPQ-16 MOD II (ORE EA.)	IFLOT MO-1, CTR-1 BC-4-JCOR BC-600MM HDC 1000MM																			(D)DH-70(200BPS) (M)DH-71(400BPS) (D)TE-202-0(1000BPS)	CAPE KENNEDY TARGET ACQUISITION BUS	X, Y, Z, 480 TONE BURST			
CAPE MATIERAS MSL TRK SITE PAMILCO SOUND, N.C.		ROT1 BC-4 CINETHECO																								
COCOA BEACH MSL TRK SITE - 35 COCOA BEACH FLA																										
EAST ATLANTIC BOA STA ATLANTIC																										
ELEUTHERA MSL TRK STA - 04 ELEUTHERA ISL	LOMAC	BC-4 MRC 1000MM																								
FERNANDO DE NOR MSL TRK STA BRAZIL																										
GRAND BAHAMA MSL TRK STA - 03 GRAND BAHAMA ISL	ANFPQ-13 SN 19	BC-4 MRC 1000MM	1-TAA-2 1-TAA-3A	1-1218 (NASA OWNED TO MOVIED)	57-5005	1-TDM1 TEST 3-TDM1-1 1-TDM1	36-EMR 210A	10-AMR 1400 2-MINCOM RCDF	5-OSCILG MH-1612 6-PEN MK200	1-SPAC (2DSSB) 2-DATA MODULATOR (HONEYWELL)	2-KY-171 1-D/R CMD SET	2-ANFRW-2 2-2400	2-ANFRW-2 2-2400	1-ANFRW-3	1-OSCILG MK200 1-20 PEN MD AW	2-STERLING 10KW 2-STEERABLE ESCO	CENTRAL TMS SYS TMS TERM SYS VHF DISTRIB SYS MICROWAVE LINK	ANVYK-1	(M)DH-69(200BPS) (M)DH-71(400BPS) (D)DH-72(400BPS)	RATAC	X, Y, Z, 480 TONE BURST					
GRAND TURK MSL TRK STA - 07 GRAND TURK ISL	ANFPQ-18	BC-4 BC-600MM	1-TAA3 2-TELTRAC 1-TAA-8		24-5005	1-TDM1 TEST 1-TDM1	5-EMR 229A	4-AMR 1400	2-OSCILG CECS-125	1-DATA MODULATOR (HONEYWELL)	2-KY-171 1-D/R CMD SET	2-ANFRW-2 2-2400	2-ANFRW-2 2-2400	1-ANFRW-3	1-OSCILG MK200 1-20 PEN MD AW	2-STERLING 10KW 1-CONICAL UNIFOLE 1-STEERABLE USA	CENTRAL TMS SYS TMS TERM SYS	ANVYK-1	(M)DH-69(200BPS) (M)DH-71(400BPS) (D)DH-72(400BPS)	RATAC	X, Y, Z, 480 TONE BURST	BOA HYDROPHONES TARGET ARRAY HYDROPHONES MILS DATA RCDFS				
GREAT STURBUS MSL TRK STA - 56 BERRY ISLAND																										
LITTLE CARTER MSL TRK STA - 42 LITTLE BAHAMA BANK																										

*STATION COMPUTER

SUMMARY OF RANGE INSTRUMENTATION (CONT'D)
TABLE XII

STATION	TRACKING		TELEMETRY										TIMING SEE A-600106	DATA HANDLING - TRANSMISSION			SHIP POSITION	
	RADAR SYSTEM	OPTICS	ANTENNAS	COMPUTER	RECEIVERS	TDM	DISCRIMINATORS		RECORDERS		RTTDS	MODEM/DEMODULATOR		SYSTEM NAME	LOCAL COORD.	IMPACT	LORAC	NAVIGATION
							TUNABLE	FIXED	MAGNETIC	GRAPHICS								
MARSH HARBOR LORAC SITE 43 GREAT ABACO ISLAND															LORAC			
MELBOURNE BCH MSL TRK SITE 36 FLORIDA		ROTI BC-4													ORAC REF STA B NET			
MERRITT ISLAND LAUNCH AREA STA 19 FLORIDA	AN/TPG-18	CINETHEOD MOT IGOR	1 - TAA-3A 3 - TAM-1	1 - BECKMAN 420	84 - TMR-15	3 - TDM1 TEST 4 - TDM1 2 - TDM2 TEST 3 - TDM2 7 - TDM3	42 - EMR 229A 144 - EMR 210A	23 - AMR 1400 6 - M-32 6 - M-32 6 - POTTER TRANS 3 - CP-200 1 - MINCOM CM 100	32 - OSCILG MH-1612 40 - FEN MK200	RTTDS CENTRAL SITE EQUIPMENT 1 - RCE 4 - DATA DEMODULATOR (HONEYWELL)								
MIAMI BEACH TRK ANNEX 31 MIAMI BEACH FLORIDA																		
NEW SMYRNA BCH MSL TRK SITE 47 FLORIDA		IGOR																
NO. JUPITER MSL SITE 39 FLORIDA		BC-4													LORAC END STA A NET			
NORTH RIDING POINT LORAC SITE GRAND BAHAMA ISLAND															LORAC REF STA A NET			
OPTIC AIRCRAFT PATRICK AFB, FLORIDA																		
RIS GEN ARNOLD T-AGM-9 PACIFIC OCEAN	INTEGRATED INSTRUMENTATION RADAR (C & L-BANDS)	IFLOT	1 - TAA-6	1 - UNIVAC 1206	12 - 5005 8 - 4017	1 - TDM2 TEST 1 - TDM1 1 - TDM2	4 - EMR 229A 18 - DCS GFD-2	2 - AMR 1400 2 - YR 3600	4 - MK200 3 - OSCILG MH-1612	1 - SPAC (1 DSSB)		SHIPBOARD					1 - ASPS 1 - SINS 1 - SRN-9 1 - STAR TRACKER	
RIS GEN VANDENBERG T-AGM-10 PACIFIC OCEAN	INTEGRATED INSTRUMENTATION RADAR (C & L-BANDS)	TFOLT	1 - TAA-6	1 - UNIVAC 1206 1 - UNIVAC 1210	12 - 5005	1 - TDM2 TEST 1 - TDM1 1 - TDM2	3 - EMR 229A 18 - DCS GFD-2	2 - AMR 1400 2 - YR 3600	4 - MK 200 4 - OSCILG MH-1612	1 - SPAC (1 DSSB)		SHIPBOARD					1 - TACAN 1 - LORAN C 1 - SINS 1 - SRN-9 1 - STAR TRACKER	
RIS REDSTONE ATLANTIC OCEAN	ASIR		4 S BAND	1 UNIVAC 1210	2 - TRKI 12	1 TDM-1 1 TDM-1A	18	5-14 TRACK	7 - PEN	1 SPAC		SHIPBOARD					AN/ERN 3 AN/SRN 9 1 MOD 5 SINS 1 MINAC 1 STAR TRACKER 1 MK19 GYRO- COMPAS EM LOG 1 ASPS	
PATRICK AFB MSL TRK STA 00 FLORIDA	AN/PPO-6	IGOR BC-4 BC-600MM CINETHEOD																
PRETORIA MSL TRK STA 13 REPUBLIC OF SOUTH AFRICA		BC-4	1 - ATJ6 1 - LOC PERIODIC	1 - 1206	12 - TMR-15 1 - 5005 1 - 5008B 1	1 - TDM1 TEST 2 - TDM1 1 - TDM2	10 - EMR 229A 36 - EMR 210A	2 - AMR 1400	4 - OSCILG MH-1612 4 - FEN MK200			OFF CABLE						
RAMEY MSL TRK SITE 58 PUERTO RICO																		
TELEMETRY AIRCRAFT PATRICK AFB, FLA			8 - ANT TRKG 7 FT 16 - ANT TRKG POLARIZED LH RH		32 - MR - 109 5 - TRK - 100 8 HF RCVR SY			15 - MINCOM M23				OFF CABLE					BOA HYDROPHONES MILS DATA PCDRS	
VERO BEACH MSL TRK SITE 37 VERO BEACH, FLA		ROTI BC 4 BC 600MM																