



# Cross-Layer Design For Large-Scale Sensor Networks

NATO Cross-Layer Workshop  
NRL, 3 June 2004

**Ananthram Swami**  
**US Army Research Lab**  
[aswami@arl.army.mil](mailto:aswami@arl.army.mil)  
**Adelphi, MD, 20783**  
**USA**

**Lang Tong**  
**Cornell University**  
[ltong@ece.cornell.edu](mailto:ltong@ece.cornell.edu)  
**Ithaca, NY 14853**  
**USA**

# Report Documentation Page

Form Approved  
OMB No. 0704-0188

Public reporting burden for the collection of information is estimated to average 1 hour per response, including the time for reviewing instructions, searching existing data sources, gathering and maintaining the data needed, and completing and reviewing the collection of information. Send comments regarding this burden estimate or any other aspect of this collection of information, including suggestions for reducing this burden, to Washington Headquarters Services, Directorate for Information Operations and Reports, 1215 Jefferson Davis Highway, Suite 1204, Arlington VA 22202-4302. Respondents should be aware that notwithstanding any other provision of law, no person shall be subject to a penalty for failing to comply with a collection of information if it does not display a currently valid OMB control number.

1. REPORT DATE <b>01 DEC 2007</b>		2. REPORT TYPE <b>N/A</b>		3. DATES COVERED	
4. TITLE AND SUBTITLE <b>Cross Cross-Layer Design For Large Large-Scale Sensor Networks</b>				5a. CONTRACT NUMBER	
				5b. GRANT NUMBER	
				5c. PROGRAM ELEMENT NUMBER	
6. AUTHOR(S)				5d. PROJECT NUMBER	
				5e. TASK NUMBER	
				5f. WORK UNIT NUMBER	
7. PERFORMING ORGANIZATION NAME(S) AND ADDRESS(ES) <b>US Army Research Lab Adelphi, MD, 20783 USA</b>				8. PERFORMING ORGANIZATION REPORT NUMBER	
9. SPONSORING/MONITORING AGENCY NAME(S) AND ADDRESS(ES)				10. SPONSOR/MONITOR'S ACRONYM(S)	
				11. SPONSOR/MONITOR'S REPORT NUMBER(S)	
12. DISTRIBUTION/AVAILABILITY STATEMENT <b>Approved for public release, distribution unlimited.</b>					
13. SUPPLEMENTARY NOTES					
14. ABSTRACT					
15. SUBJECT TERMS					
16. SECURITY CLASSIFICATION OF:			17. LIMITATION OF ABSTRACT <b>UU</b>	18. NUMBER OF PAGES <b>28</b>	19a. NAME OF RESPONSIBLE PERSON
a. REPORT <b>unclassified</b>	b. ABSTRACT <b>unclassified</b>	c. THIS PAGE <b>unclassified</b>			

# Network Overhead is Costly!

- Network Functions Are Dominant Users of Bandwidth
- Fixed Overhead Increasingly Less Efficient as Duty Cycle Decreases
- Closed Loop Mechanisms Require Duplex Operation
- Much of Bandwidth Provides Redundant/Unnecessary Information

- Headers for Each Level
- Timing
- Status

*Redundant since information exists in the Integrated system*

**SUOSAS Aggregate 200 Mbps Capability**

512 byte packet, 32 mpps & FEC = 1/2 @ 4000 kbps maximum burst

	Bits (in K)	Reduction %	Payload
Transmission Capacity of 50 Radios	200,000		
Half-Duplex Operation	100,000	100,000	
Channel Contention @ 5 Radio Density	40,000	60,000	
UDP Header	39,385	615	34%
IP Header	37,647	1,738	95%
COMSEC Header	36,571	1,076	59%
Radio Network Header	36,120	451	25%
Radio Link Layer Header	35,679	441	24%
Modem Framing & CRC	35,068	611	34%
Forward Error Correction	17,534	17,534	
Waveform Framing	17,491	43	2%
Synchronization Probe Overhead	13,378	4,113	226%
Slot Quantization @ 1.2 ms per Slot	11,378	2,000	110%
Channel Acquisition (RTS/CTS)	6,827	4,551	250%
Frame Acknowledge	5,689	1,138	62%
Average Contention Interval (1.44 slots)	4,588	1,101	60%
Average Number of Transmissions per packet	1,821	2,767	
Candidate Packet Overhead			982%

From SUO SAS TIM, June 12 & 13 2001

**Actual Application Data 1.8 Mbps ≈ 0.9 %**

- Does Not Include Initial Acquisition, Other Entry Requests, TCP, Routing Table, and Related Bandwidth Requirements
- 10 Second Set-up Time Represents Opportunity Cost of 2 Gigabits of Throughput

(DARPA Connectionless Networks)

APPROVED FOR PUBLIC RELEASE

→ Motivates cross-layer design  
→ Architecture vs. Performance

# Low Duty-Cycled Sensor Network Demands Different Kind of Radio

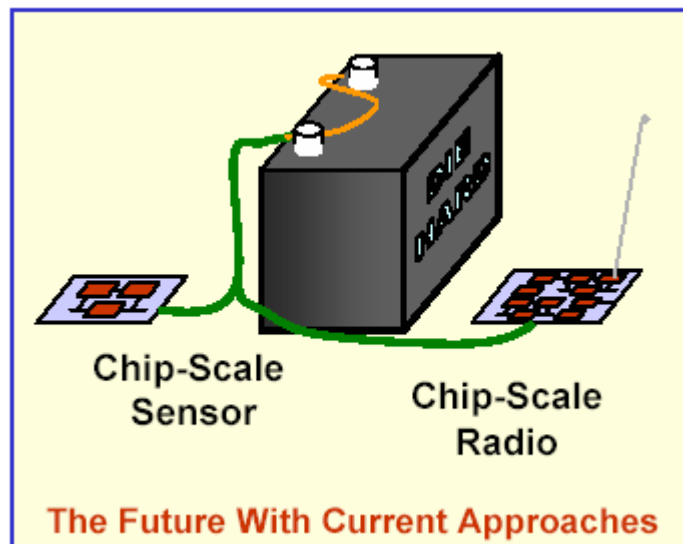

- ✓ Energy consumed in “staying awake”
- ✗ Moore’s “law” does not extend to Shannon / Maxwell
- Motivates cross-layer design

# FCS (UOA) Network Communications Architecture

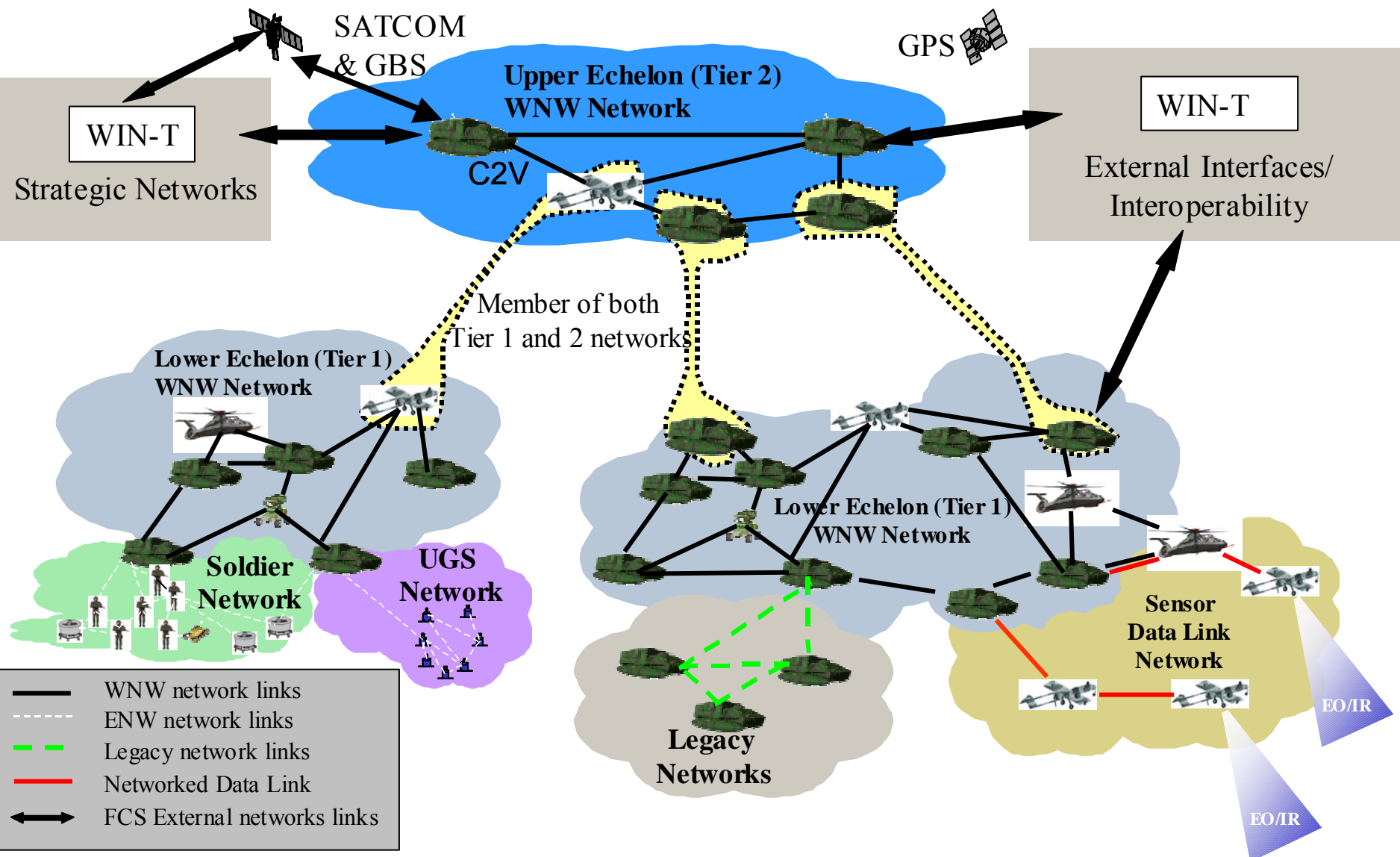

# Outline

- **Basic sensor network problems**  
Distributed Detection  
Estimation  
PHY-MAC

## Some Questions:

- What makes a sensor network different?
- Current methodologies / architectures adequate?
- What are the challenges ?
- Who owns / controls the sensor ?
- Who has access to the sensor ?
- How many sensors are alive? For how long?
- Should sensors talk to each other : how much ?
- **MAC issues:**
  - Nodes may have only one packet to send (no stability issue)
  - Nodes have finite battery : listening consumes energy
  - ‘Send when the channel is good’
  - How to control sensors

➤ **Motivates judicious cross-layer design**

# Large Scale Sensor Networks

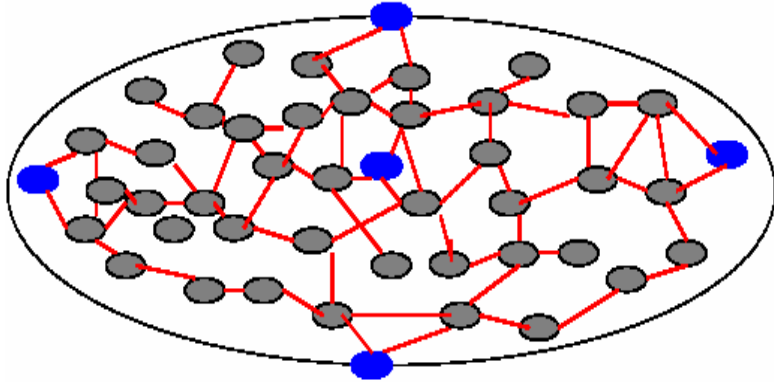

## Applications:

- Infrastructure security / area denial
- Traffic control
- Habitat monitoring
- Target detection / tracking
- Chem-bio-Rad detection
- DSN, SensIT, Rembass, TRSS, CEC, FDS, ADS, SoSuS

## Nodes:

- Randomly deployed
- Many nodes, wide area
- Low power, low duty cycle
- Low cost and complexity
- Asynchrony

## Channel :

- Fading, path loss; NLOS
- CCI / CSI; Jamming

## Network:

- Peer-to-peer or Hierarchical ?
- Packets to/from gateway nodes
- Gateways may be mobile
- Correlated / asymmetric traffic

- **Interplay between sensing, SP, comms and control**
- **Data-centric paradigm**

# One Hop or Multi-Hop

Transmitting one bit:  $E_{\text{tx}}(r) = e_{\text{tx}} + \max\{e_{\text{min}}, e_{\text{out}} r^{-\alpha}\}$ .

Hardware limit on  $r$ :  $r \geq r_0 = \left(\frac{e_{\text{min}}}{e_{\text{out}}}\right)^{\frac{1}{\alpha}}$

Energy consumption in one hop

$$\mathcal{E}_1(r) = E_{\text{tx}}(r) + \left(\frac{r^2}{R^2}(N - 1)\right)E_{\text{rx}}$$

Minimum Transmission Range

$$r \geq r_{\text{min}} \triangleq \max\left\{r_0, R\sqrt{\frac{\log N}{N}}\right\}$$

# Energy efficiency: a case for mobility

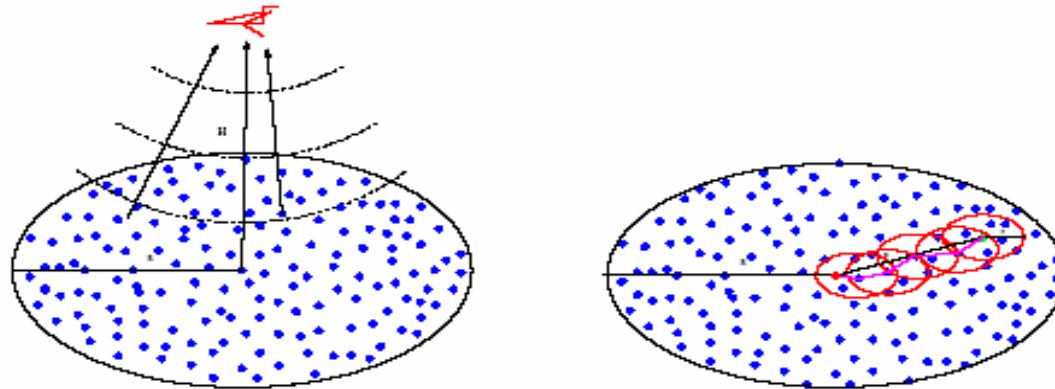

$$\mathcal{E}_{\text{SENMA}} = E_{\text{tx}}(H) = \mathcal{O}(1)$$

$$\mathcal{E}_{\text{AdHoc}} = \begin{cases} \mathcal{O}(\sqrt{N \log N}) & \rho \uparrow, r_0 = 0 \\ \mathcal{O}(N) & \rho \uparrow, r_0 > 0 \\ \mathcal{O}(\sqrt{N(\log N)^{\alpha-1}}) & R \uparrow \end{cases}$$

## Remark

If  $\mathcal{O}(\sqrt{N})$  number of packets are to be extracted, then **energy consumption per node** is unbounded as  $N \rightarrow \infty$  without perfect scheduling!

→ Listening / Routing dominates energy consumption

# UGS: Unattended Ground Sensor Array

SOME SENSORS

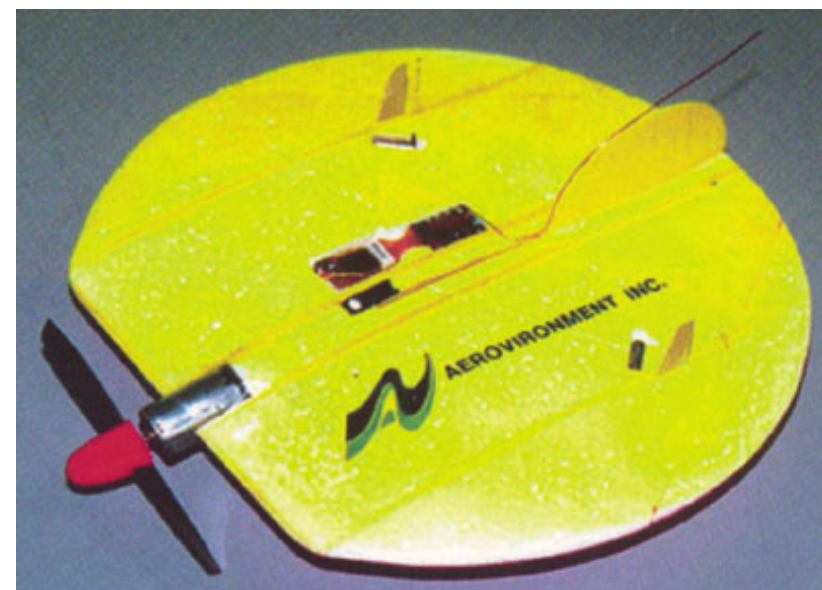
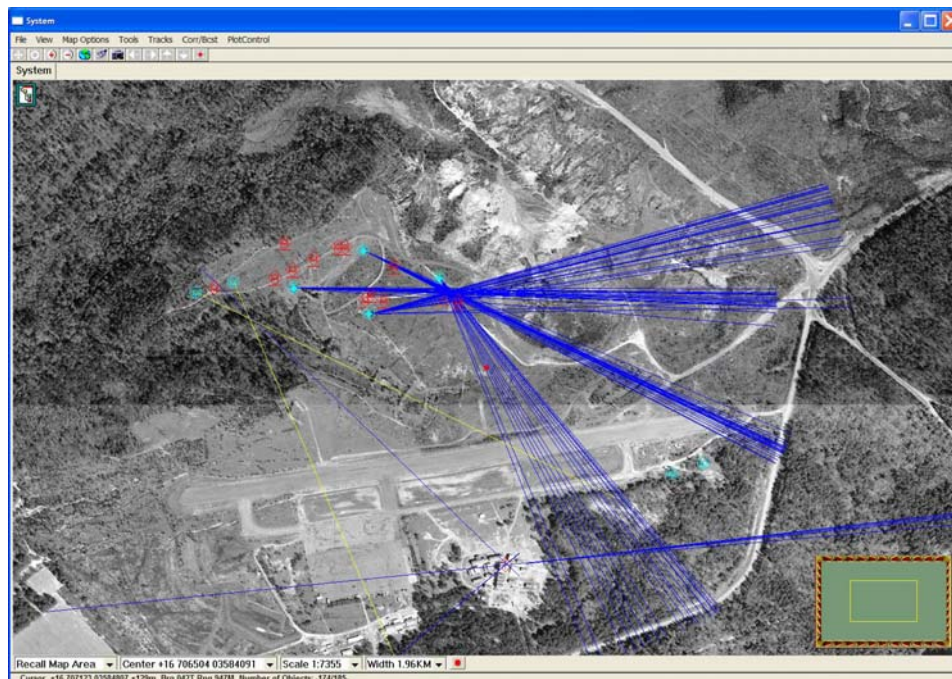
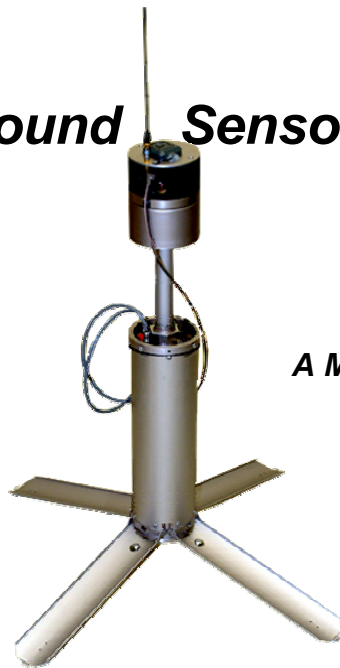

APPROVED FOR PUBLIC RELEASE

An UGS array of IR and acoustic sensors track a convoy.

PACBOT



# Cross-Layer Design with Mobility

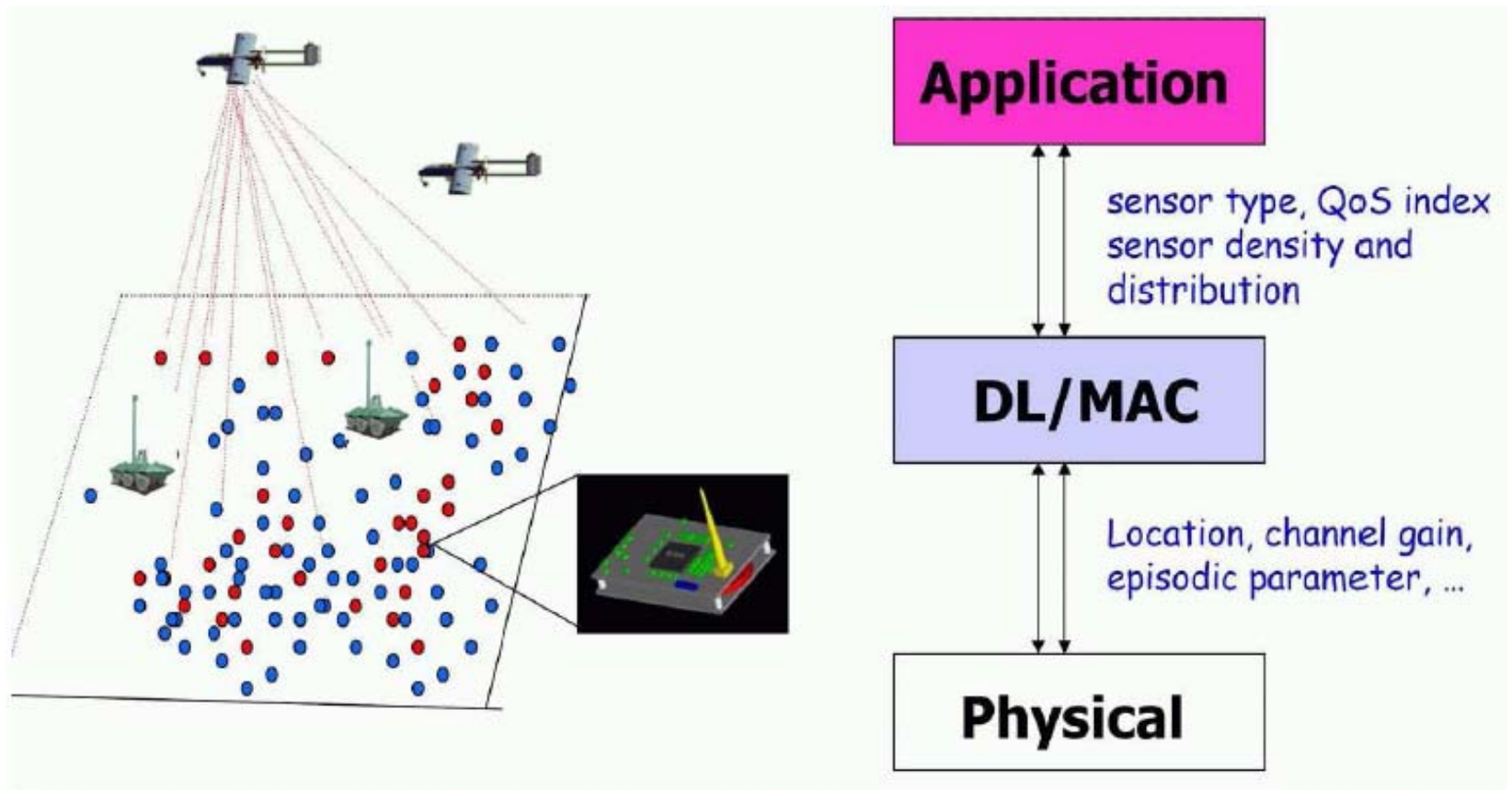

# Outline

- Basic sensor network problems
  - Distributed Detection**
  - Estimation
  - PHY-MAC

# Example 1: (Distributed) Detection

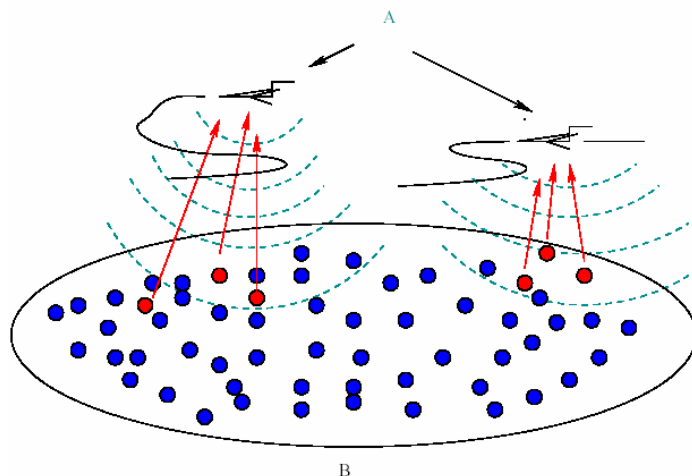

- ✓ Optimal fusion rule?
- ✓ Optimal local threshold?
- (APP-MAC-PHY interaction)
- ✗ How many bits per sensor ?
- ✗ Identical sensors?
- ✗ With correlated data?

- $Y_i = W_i + \theta s(X_i)$  :  $W$  iid
- Binary sensors
- RA channel

## Approach:

- *Local* problem:  $\theta \sim 0$
- *Asymptotic*: Many sensors
- *Randomly* distributed sensors
- *Marked thinned IPP*

[STS, 2004]

# Non-Randomized ALMP Global Detector

- **Optimal Fusion Rule:** Decide  $H_1$  ( $\theta > 0$ ) if  $\Delta_{n,o} > Q^{-1}(\alpha)$

$$\Delta_{n,o} = [ \sum_A s(x_i) - n \lambda_o \int_A s(x) dx ] / [ n \lambda_o \int_A s^2(x) dx ]^{1/2}$$

- **Power under fixed global size:**

$$\rightarrow Q( Q^{-1}(\alpha) - \theta [ n \lambda_h p_m [\beta'(0; \tau_o)]^2 / \beta(0; \tau_o) \int_A s^2(x) dx ]^{1/2} )$$

- **Optimal local threshold:**  $\tau_{opt} = \arg \max \{ [\beta'(0; \tau)]^2 / \beta(0; \tau) \}$

- **For AWGN channel:**  $\tau_{opt} = 0.612 \sigma_w$

**$\rightarrow$  local size = 0.27 : 'poor' sensors**

- Error decreases exponentially in "SNR"
- Build a better MAC? Increase sensor density?

$$\lambda_o = \lambda_h p_m \beta(0; \tau_o)$$

- $\rightarrow n p_m$  must increase with  $n$  :

# Outline

- Basic sensor network problems
  - Distributed Detection
  - Estimation**
  - PHY-MAC

# Impact of MAC on Estimation

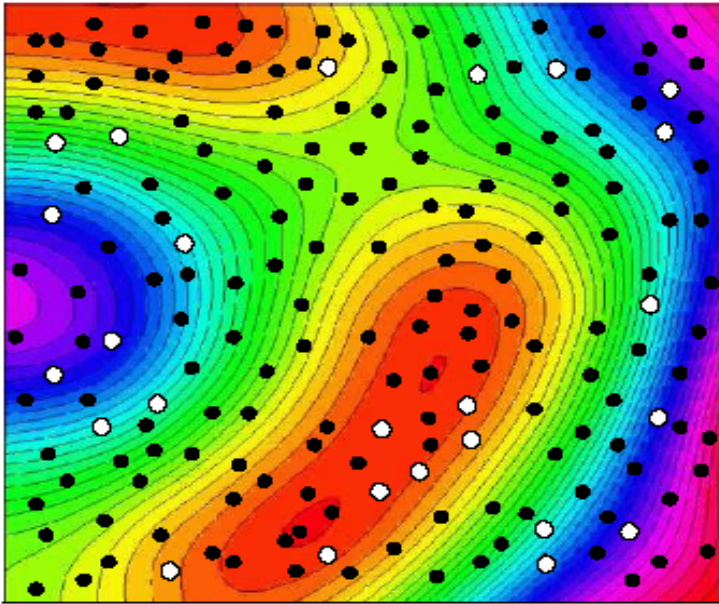

Random Access

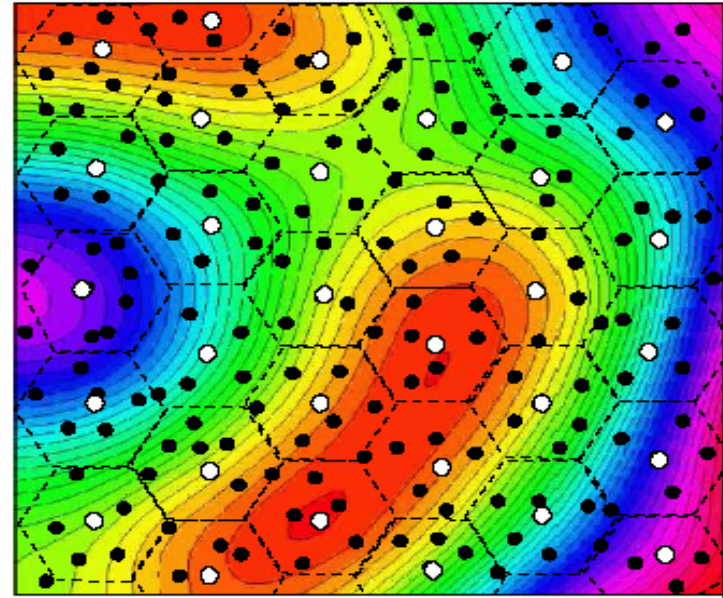

Deterministic Scheduling

Which MAC is preferable?

# Random or Regular Sampling ? Random Access or Scheduling ?

## Assumptions:

- Dense network; sensors know locations
- AR(1) model for data : `interpolation`
- Metric: Expected Maximum Distortion
- Random access needs  $O(\log K)$  more packets;  
has  $O(\log K)$  higher excess MSE:

$$\mathbf{M}_D = \mathbf{O} ( \mathbf{M}_R / \ln \mathbf{M}_R )$$

$$\mathbf{r}(\mathbf{K}, \mathbf{SNR}) = \ln (\mathbf{K}) + \mathbf{O}( .. )$$

*Should we always schedule ?*

[DTS, 2003]

### 3. Estimation: Finite Density Networks

- DS: sensor may not exist
- RA: Collision channel

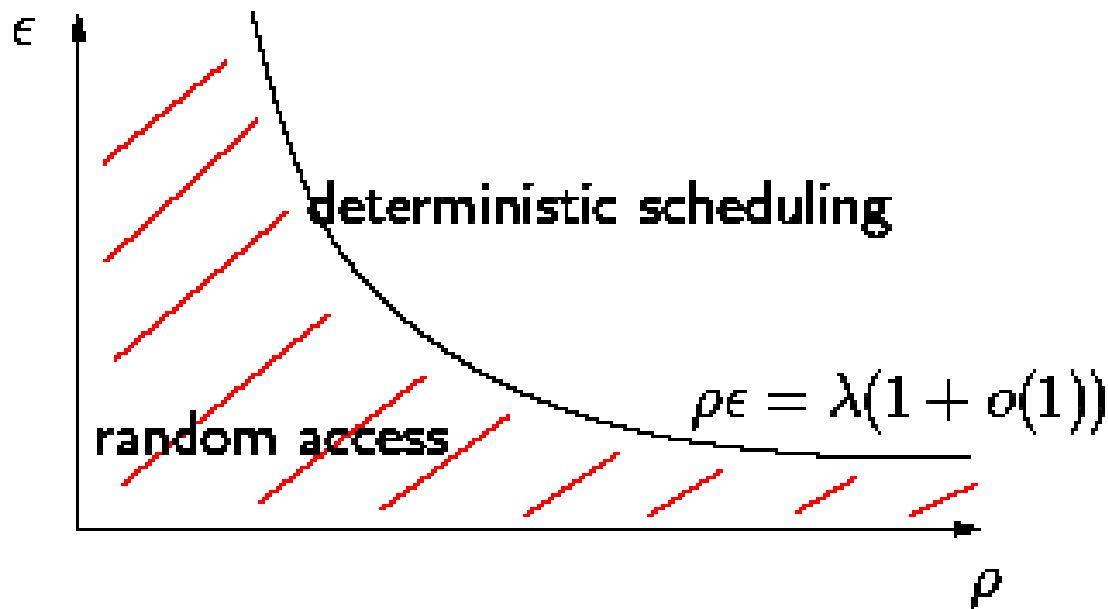

# Outline

- Basic sensor network problems
  - Distributed Detection
  - Estimation
  - PHY-MAC**

# Opportunistic MAC

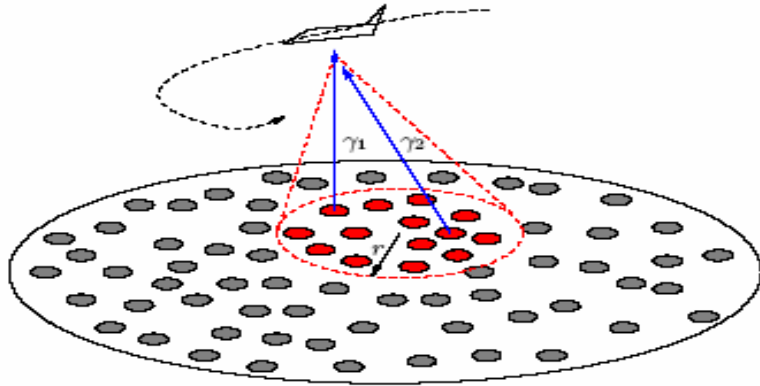

- Mobility induces fading
- Wait for a good channel

## Distributed Opportunistic MAC

- **Channel Acquisition**  
Estimate  $\gamma$  from beacon.
- **Opportunistic ALOHA**  
Transmit with probability  $s(\gamma)$ .
- **Opportunistic CSMA**
  - Sense carrier with backoff  $\tau(\gamma)$ .

## Advantages

- Simplicity. □ Scalability.
- Energy Efficiency.

- Transmit with probability based on CSI : O-ALOHA

# Example 4: Optimal Detection for MAC

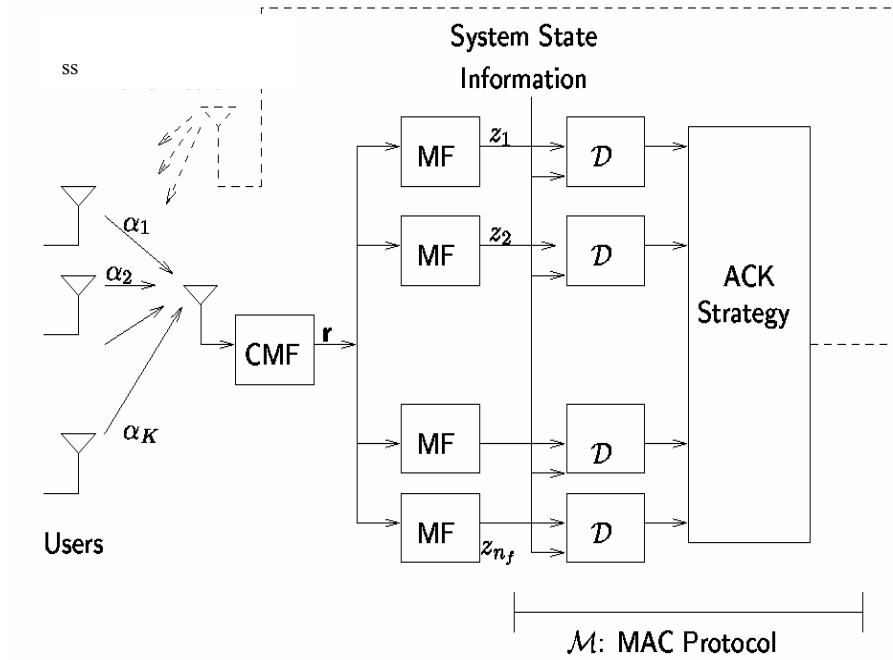

## Optimal Detection at the Receiver:

- MAC assumes accurate detection of requests.
  - RTS-CTS exchanges. Busy-tone detection.
- Missed detections and false alarms likely in interference-rich environment
  - What is the impact on the MAC?
  - How do we model PHY / MAC interaction ?
- What is the detector that optimizes the MAC performance (throughput and delays)?
- Markov chain formulation / Optimal Bayesian detector

[MTS, 2003]

# Signal Model

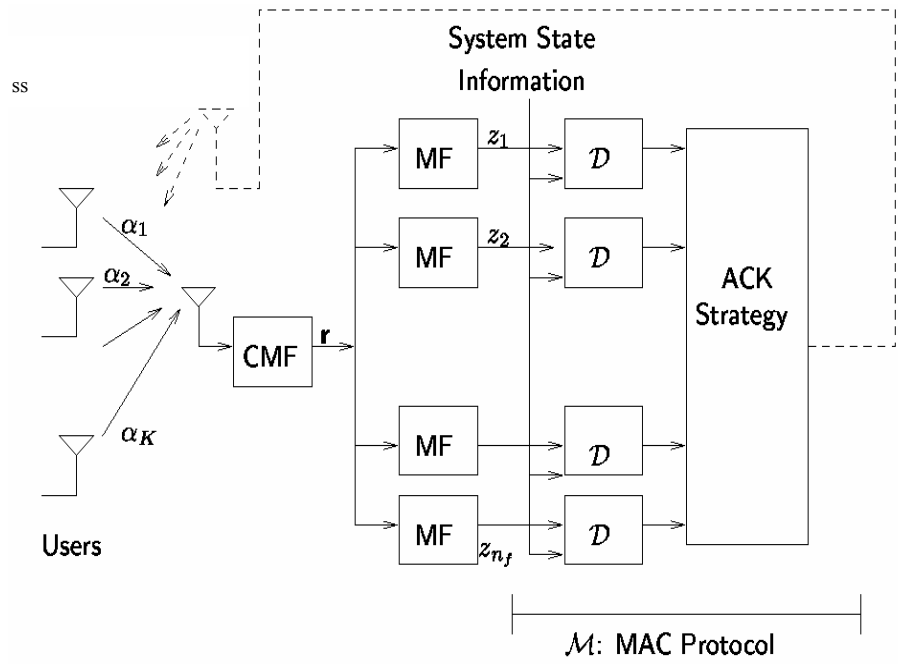

Users select random codes  
Unknown fades

$N = \#$  orthogonal codes  
 $f = \#$  free codes  
 $L =$  packet length  
 $\lambda =$  arrival rate

MF output is a sufficient statistic:  $\sim \text{CN}(0, K_i \sigma^2 + \sigma_v^2)$   $K$  is unknown.

Traffic: Poisson w aggregate rate  $\lambda \rightarrow K$  is Poisson ( $\lambda / f$ )

PHY-MAC problem:  $K = 1 ?$  Metric ?

Two Approaches:

- Optimal detection + optimal scheduling
- Joint optimization to maximize throughput

# Markov Chain for N=2, L=3

$\alpha(f)$  = Prob of ACK'ing a channel, given  $f$  free channels

$$\beta(f) = 1 - \alpha(f)$$

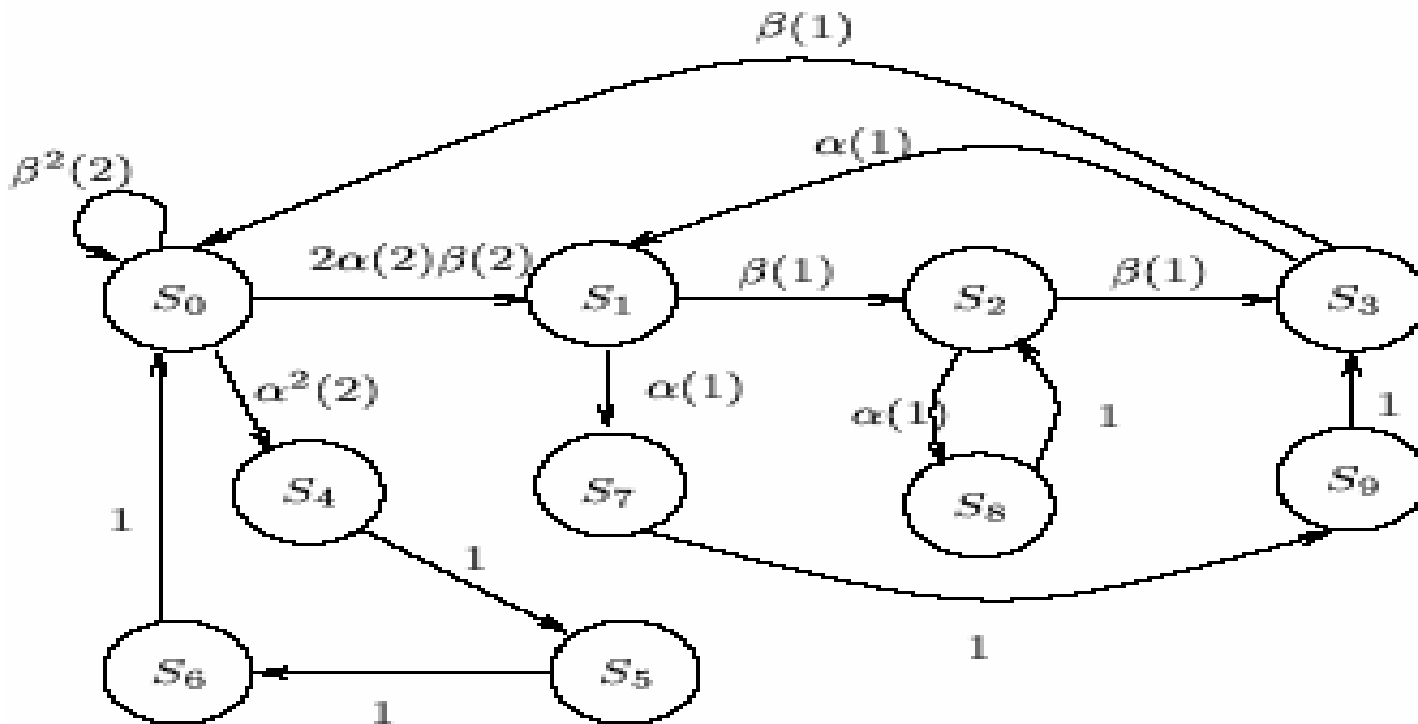

Symbol	State	$f_i$
$S_0$	[0 0 0]	2
$S_1$	[0 0 1]	1
$S_2$	[0 1 0]	1
$S_3$	[1 0 0]	1
$S_4$	[0 0 2]	0
$S_5$	[0 2 0]	0
$S_6$	[2 0 0]	0
$S_7$	[0 1 1]	0
$S_8$	[1 0 1]	0
$S_9$	[1 1 0]	0

\*  $\forall N, L$ , Markov chain is finite, aperiodic, and irreducible  $\rightarrow$  Steady state distribution  $\pi_{\delta}$  exists

# Optimal Decision Regions

vs. arrival rate

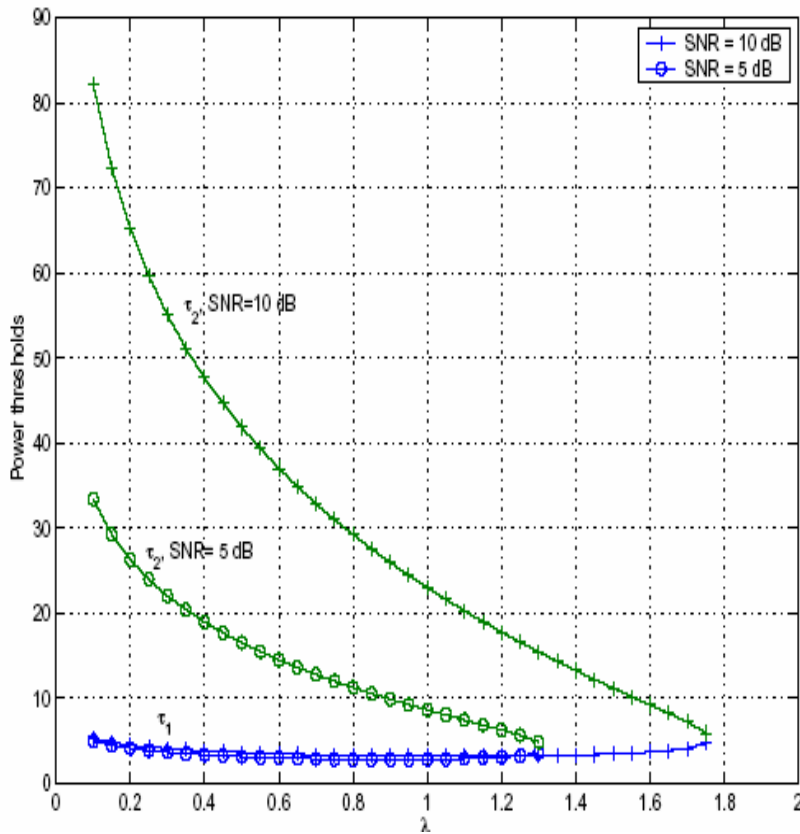

vs. SNR

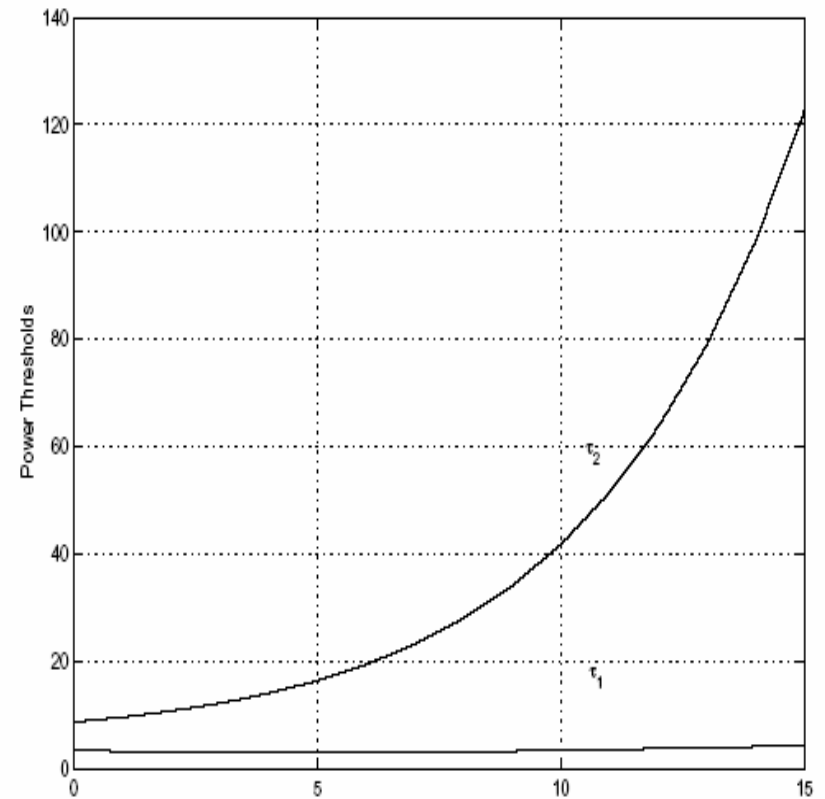

# Utilization vs. Traffic Rate

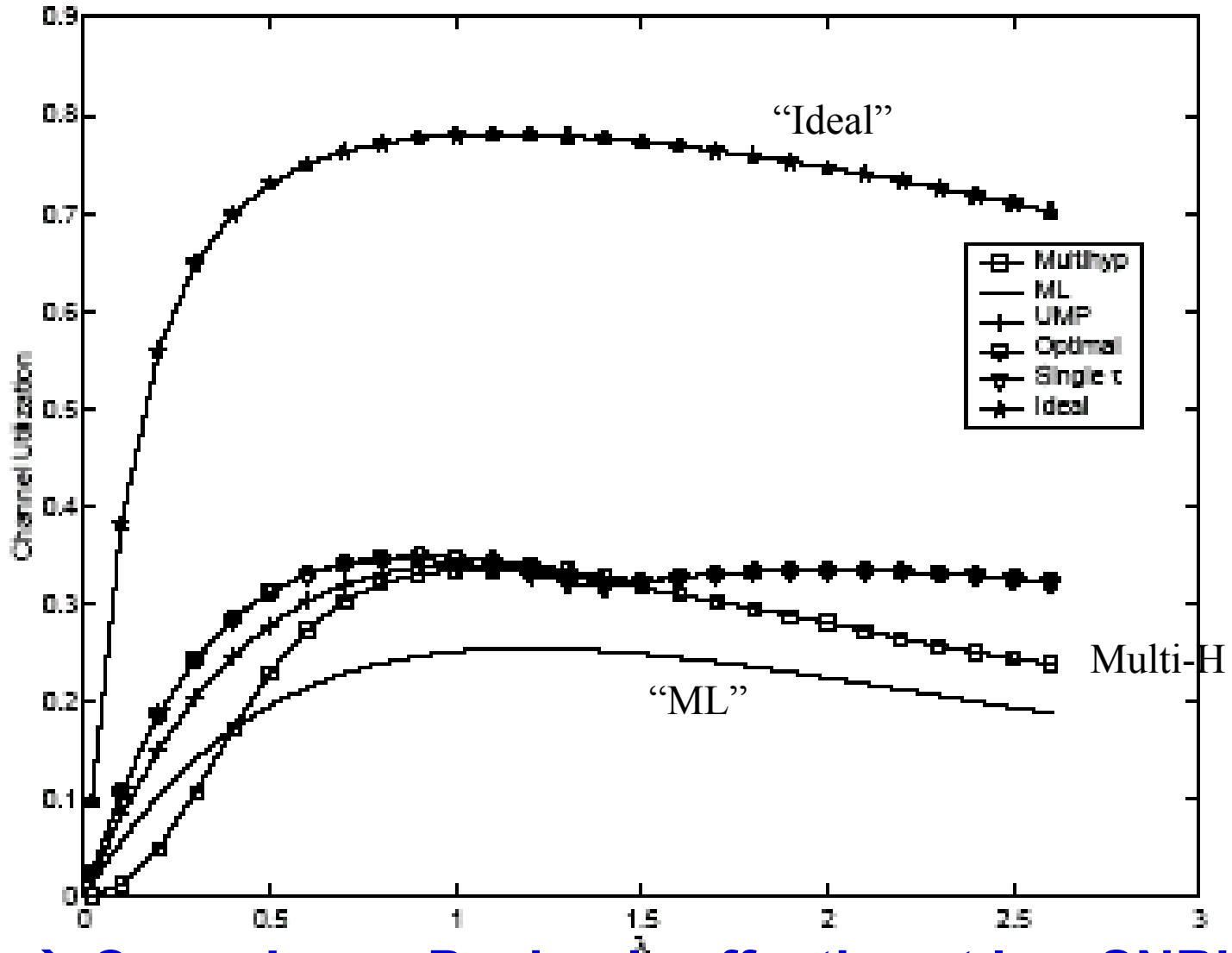

→ Cross-Layer Design is effective at low SNR's

# Utilization Curves

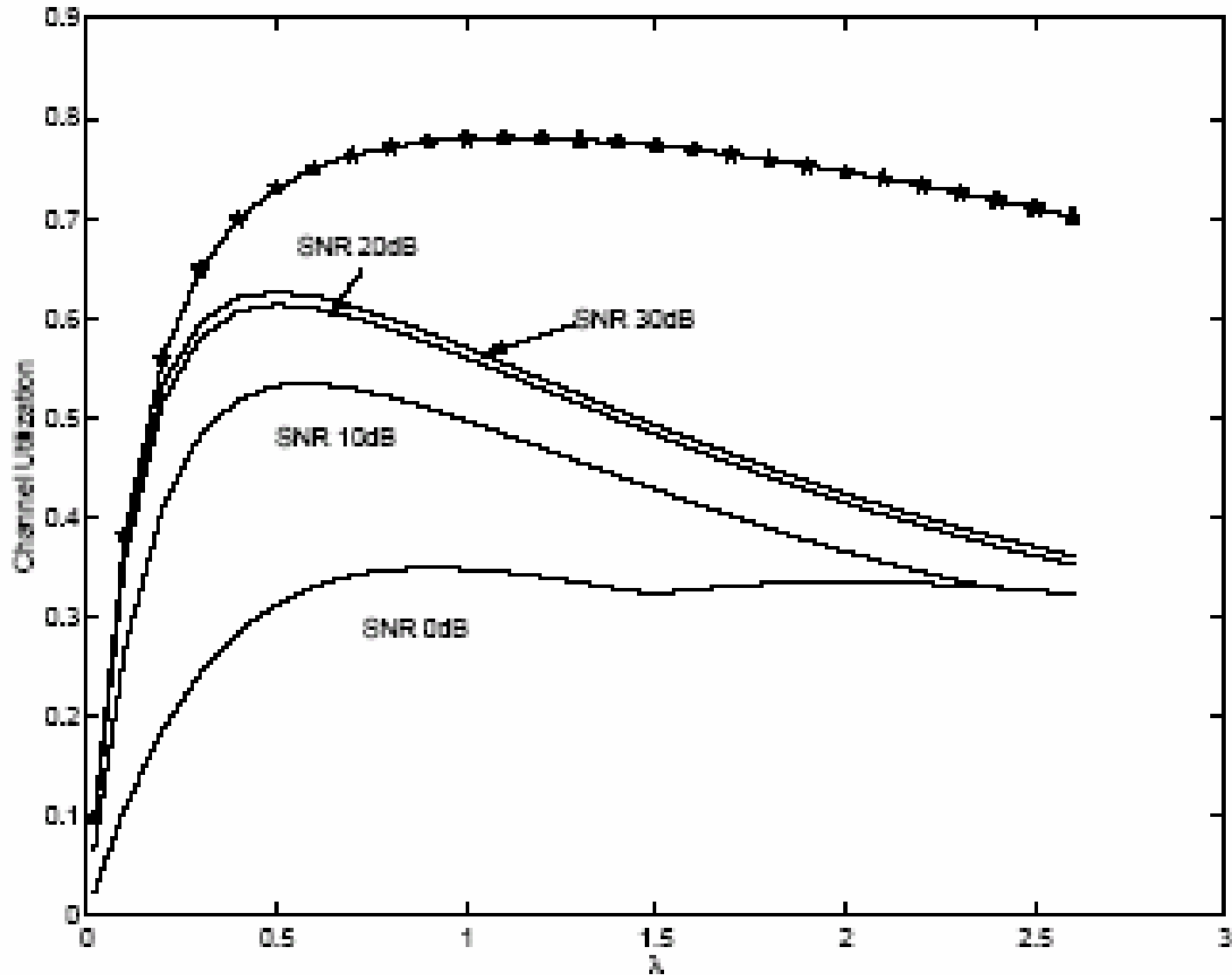

→ A Gap still exists

# Cross-Layer Design

- promises adaptability, agility, efficiency.
- Does not always imply improved performance.
- Potential for instability
- Sensor networks are application specific; PHY+MAC+APP cross-layering natural.

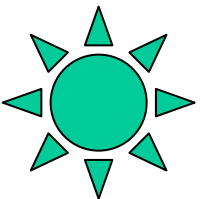

# References

- [MZT, 2004] G. Mergen, Q. Zhao, L. Tong, ``Sensor networks with mobile access: energy and capacity considerations'', submitted to IEEE Trans. Comm, Jan 2004
- [STS, 2004] Y. Sung, L. Tong, A. Swami: ALOD for large scale sensor network under the Poisson regime; ICASSP 2004; to appear in IEEE Trans. Sig. Proc.
- [DTS, 2003] M. Dong, L. Tong, B.M. Sadler, ``Source reconstruction via mobile agents in sensor networks: throughput distortion characteristics'', MILCOM 2003
- [VAT, 2004] P. Venkitasubramaniam, S. Adireddy, L Tong, ``Sensor networks with mobile access: optimal random access and coding'', IEEE JSAC special issue on Sensor Networks, 2004.
- [ZT, 2004] Q. Zhao, L. Tong, Distributed opportunistic information retrieval in sensor networks: CSI-based carrier sensing'', ICASSP 2004.
- [MTS, 2003] A. Maharshi, L. Tong, A. Swami, Cross-layer designs of multichannel reservation MAC under Rayleigh fading, IEEE Trans. Sig Proc, Special issue on SP & Networks, Aug 2003. .
- [ST 2004] A. Swami and L. Tong, Guest Editors, Special Issue on ``Signal Processing for Networking: An Integrated Approach'', IEEE Signal Processing Magazine, Sept 2004.