

September 2008

OPERATION IRAQI FREEDOM

Actions Needed to Enhance DOD Planning for Reposturing of U.S. Forces from Iraq



Report Documentation Page

Form Approved
OMB No. 0704-0188

Public reporting burden for the collection of information is estimated to average 1 hour per response, including the time for reviewing instructions, searching existing data sources, gathering and maintaining the data needed, and completing and reviewing the collection of information. Send comments regarding this burden estimate or any other aspect of this collection of information, including suggestions for reducing this burden, to Washington Headquarters Services, Directorate for Information Operations and Reports, 1215 Jefferson Davis Highway, Suite 1204, Arlington VA 22202-4302. Respondents should be aware that notwithstanding any other provision of law, no person shall be subject to a penalty for failing to comply with a collection of information if it does not display a currently valid OMB control number.

1. REPORT DATE SEP 2008	2. REPORT TYPE	3. DATES COVERED 00-00-2008 to 00-00-2008			
4. TITLE AND SUBTITLE Operation Iraqi Freedom. Actions Needed to Enhance DOD Planning for Reposturing of U.S. Forces from Iraq		5a. CONTRACT NUMBER			
		5b. GRANT NUMBER			
		5c. PROGRAM ELEMENT NUMBER			
6. AUTHOR(S)		5d. PROJECT NUMBER			
		5e. TASK NUMBER			
		5f. WORK UNIT NUMBER			
7. PERFORMING ORGANIZATION NAME(S) AND ADDRESS(ES) U.S. Government Accountability Office, 441 G Street NW, Washington, DC, 20548		8. PERFORMING ORGANIZATION REPORT NUMBER			
9. SPONSORING/MONITORING AGENCY NAME(S) AND ADDRESS(ES)		10. SPONSOR/MONITOR'S ACRONYM(S)			
		11. SPONSOR/MONITOR'S REPORT NUMBER(S)			
12. DISTRIBUTION/AVAILABILITY STATEMENT Approved for public release; distribution unlimited					
13. SUPPLEMENTARY NOTES					
14. ABSTRACT					
15. SUBJECT TERMS					
16. SECURITY CLASSIFICATION OF:			17. LIMITATION OF ABSTRACT	18. NUMBER OF PAGES	19a. NAME OF RESPONSIBLE PERSON
a. REPORT unclassified	b. ABSTRACT unclassified	c. THIS PAGE unclassified	Same as Report (SAR)	85	



Highlights of [GAO-08-930](#), a report to congressional committees.

Why GAO Did This Study

The redeployment of U.S. forces from Iraq, a process the Department of Defense (DOD) refers to as “reposturing,” will be a massive and expensive effort. As of March 2008, for example, there were about 173,000 pieces of equipment in Iraq, worth about \$16.5 billion, that will need to be returned to the United States. The redeployment process following Operation Desert Storm in 1991, a much shorter war, lasted at least 14 months. DOD guidance emphasizes the importance of early planning for this redeployment process.

GAO performed this work under the Comptroller General’s Authority. GAO examined the (1) status of logistical planning for reposturing U.S. forces from Iraq and associated assumptions and (2) extent to which DOD established roles and responsibilities for managing and executing retrograde from Iraq. GAO also identified issues that DOD will need to consider in its reposture planning. GAO reviewed documents and interviewed officials from over 20 DOD organizations in the United States and Kuwait.

What GAO Recommends

GAO recommends that the Secretary of Defense take steps to clarify the chain of command over logistical operations for retrograde of equipment and materiel. Also, Congress may wish to consider directing DOD to report specific details on the status of reposturing plans and how it intends to mitigate issues such as those we identify. DOD generally concurred with our recommendations.

To view the full product, including the scope and methodology, click on [GAO-08-930](#). For more information, contact William M. Solis at 202-512-8365 or solisw@gao.gov

OPERATION IRAQI FREEDOM

Actions Needed to Enhance DOD Planning for Reposturing of U.S. Forces from Iraq

What GAO Found

While the pace and overall extent of reposturing in Iraq is yet to be determined, various defense commands began planning for reposturing in fall 2007, and DOD began coordinating these individual planning efforts in May 2008 to develop a logistical framework based on three key assumptions. The result of this planning was an order published by Multi-National Forces-Iraq (MNF-I) that contained the process for reposturing units, materiel, and equipment and established working groups to continue the planning and seek solutions to emerging challenges. DOD’s three key assumptions are: (1) any reposturing initiative will be based on MNF-I and Department of State assessments of conditions on the ground; (2) there will be sufficient lead time to refine reposture plans once an order with a specific timetable and force posture in Iraq is issued; and (3) the reposturing of forces will be deliberate and gradual, predicated on a 180-day process for units leaving Iraq and a sustained flow of no more than 2.5 brigades’ worth of equipment and materiel out of Iraq each month.

While efforts have been made to synchronize planning for reposturing, DOD, U.S. Central Command (CENTCOM), and the military services have not yet clearly established all of the roles and responsibilities for managing and executing the retrograde of materiel and equipment from Iraq. Although CENTCOM has designated U.S. Army Central (ARCENT) as executive agent for synchronizing retrograde of materiel and equipment from the Iraqi theater of operations, no unified or coordinated structure exists to account for the roles of the variety of teams and units engaged in retrograde operations. Until recently ARCENT did not have operational control over the two units responsible for retrograding the bulk of equipment in Iraq.

We identified the following nine issues that DOD should consider as it develops a comprehensive plan for reposturing U.S. forces from Iraq: (1) agreed-upon guidance for environmental cleanup and the disposition of property, which could affect the time and cost of closing bases in Iraq; (2) guidance and plans for the reposturing of contractors from Iraq; (3) accountability and disposition of contractor-managed government-owned property; (4) the possibility of restrictive conditions on the use of facilities in Kuwait and other neighboring countries; (5) availability of power-washing equipment and stands, called wash racks, and the number of customs inspectors in Kuwait; (6) capacity of military transports and convoy security assets, including limits on the main supply route; (7) increased demand for access to mental health care providers; (8) infrastructure requirements of returning units; and (9) requirements for training and equipment reset to restore readiness. DOD has begun to address these issues.

While the National Defense Authorization Act for fiscal year 2008 directs DOD to brief the congressional defense committees on certain issues related to reposturing, DOD is not required to provide the specific information identified in our report. We believe that without more specific reporting from DOD, Congress may not be able to effectively exercise its oversight responsibilities.

Contents

Letter		1
	Results in Brief	4
	Background	7
	Planning Efforts, Begun in Fall 2007 and Coordinated in 2008, Are Predicated on Three Key Assumptions	11
	Executive Agent for Retrograde of Materiel and Equipment Lacks Necessary Authority	16
	Issues That DOD Needs to Consider in Its Reposture Planning	23
	Conclusions	36
	Recommendations	37
	Matter for Congressional Consideration	37
	Agency Comments and Our Evaluation	37
Appendix I	Scope and Methodology	41
Appendix II	Comments from the Department of Defense	44
Appendix III	Department of Defense Classes of Supply	71
Appendix IV	Theater Property and Retrograde Support Teams	72
Appendix V	Theater Logistical Infrastructure Throughput Model	73
Appendix VI	Detailed Process for Shipping Excess Theater Provided Equipment	76
Appendix VII	GAO Contact and Staff Acknowledgments	80
Tables		
	Table 1: Multi-National Forces-Iraq 180-day Template	15
	Table 2: Planning Scenarios for Sustained Deployment and Redeployment	73
	Table 3: Key Planning Factors for Sustained Deployment and Redeployment, by Unit Type	74

Figures

Figure 1: Select Installations in Iraq and Key Logistics Activities in Kuwait	10
Figure 2: MNF-I Process for Disposing of Contractor-Managed Government-Owned Property	27
Figure 3: Bradley Fighting Vehicles at Wash Racks	32
Figure 4: HMMWV on Wash Rack	33
Figure 5: Process for Retrograding Class VII Theater Provided Equipment	77

This is a work of the U.S. government and is not subject to copyright protection in the United States. It may be reproduced and distributed in its entirety without further permission from GAO. However, because this work may contain copyrighted images or other material, permission from the copyright holder may be necessary if you wish to reproduce this material separately.



United States Government Accountability Office
Washington, DC 20548

September 10, 2008

Congressional Committees

Following Operation Desert Storm in 1991, a 100-hour war during which U.S. forces advanced approximately 190 miles into Iraq, it took some 14 months to redeploy most of the deployed materiel and equipment out of the theater. Operation Iraqi Freedom began in March 2003, and since that time the United States has maintained a sizeable presence in Iraq, rotating forces into and out of the country in support of ongoing operations. As of April 26, 2008, there were approximately 149,400 Department of Defense (DOD) contractors and, as of July 1, 2008, approximately 147,400 U.S. troops deployed in support of Operation Iraqi Freedom. DOD officials reported that these forces were located on approximately 311 installations, matured during 5 years of operations, with some installations more than 500 miles from Kuwait. Most of the equipment used by U.S. troops in Iraq—approximately 80 percent according to DOD officials—is theater provided equipment, which is a pool of permanent stay behind equipment consisting of specific line items of modified table of organization and equipment property, issued Army prepositioned stocks, and items purchased specifically for Operation Iraqi Freedom that remains in Iraq. Although much of this equipment has remained in Iraq as units rotate in and out, significant amounts will be brought back to the United States if and when there is a decrease in the size of U.S. forces in Iraq. As of March 2008, this pool of theater provided equipment totaled approximately 173,000 major end items such as High Mobility Multipurpose Wheeled Vehicles (HMMWV) and Mine Resistant Armor Protected (MRAP) vehicles, worth approximately \$16.5 billion. The retrograde process for returning these equipment items to the United States will be a massive and expensive effort.

In January 2007, the president announced he would temporarily increase, or “surge,” the U.S. force level in Iraq by an additional 5 brigades, bringing the total number of brigade combat teams in Iraq to 20.¹ The brigades were in place by June 2007 and began withdrawing in September 2007. In his April 2008 Report to Congress on the Situation in Iraq the commander,

¹This figure includes Army brigade combat teams and equivalent Marine Corps organizations.

Multi-National Force-Iraq (MNF-I), recommended that the drawdown from 20 to 15 brigade combat teams continue and that, upon the withdrawal of the last of these combat teams in July 2008, MNF-I undertake a 45-day period of consolidation and evaluation. At the end of that period, MNF-I would commence a process of assessment to examine the conditions on the ground and, over time, determine when it could make a recommendation for further reductions. In July 2008, however, the Chairman of the Joint Chiefs of Staff stated that, based on what he observed during a recent trip to Iraq, he expects to be able to recommend further troop reductions to the President and Secretary of Defense in the fall of 2008. In addition, in June 2008 GAO also issued its own assessment of progress in Iraq and called for a new strategy given the changing conditions.² Finally, the National Defense Authorization Act for Fiscal Year 2006 (as amended by the National Defense Authorization Act for Fiscal Year 2008) requires the President to report to the Congress quarterly on U.S. policy and military operations in Iraq, including, to the extent practical, (1) an assessment of the levels of U.S. Armed Forces required in Iraq for the 6-month period following the date of the report, the missions to be undertaken by the Armed Forces in Iraq for such period, and the incremental costs or savings of any proposed changes to such levels or missions; and (2) a description of the range of conditions that could prompt changes to the levels of U.S. Armed Forces required in Iraq for the 6-month period following the date of the report or the missions to be undertaken by the Armed Forces in Iraq for such period, including the status of planning for such changes to the levels or missions of the Armed Forces in Iraq. Not later than 30 days after submission of each subsequent report, appropriate senior DOD officials are required to brief the congressional committees on these same matters.³

While we have been monitoring the full range of challenges that DOD would likely face, both in Iraq and here in the United States, as it begins to draw down its forces in Iraq, this report is focused on the logistical organizations and processes that would support a drawdown from Iraq or, as DOD officials call it, a “reposturing” effort, especially the retrograde of

²GAO, *Securing, Stabilizing, and Rebuilding Iraq: Progress Report: Some Gains Made, Updated Strategy Needed*, GAO-08-837 (Washington, D.C.: June 23, 2008).

³National Defense Authorization Act for Fiscal Year 2006, Pub. L. No. 109-163, § 1227 (2006) (as amended by the National Defense Authorization Act for Fiscal Year 2008, Pub. L. No. 110-181, § 1223 (2008)).

materiel and equipment.⁴ Our analysis indicated that the redeployment of military personnel, although important, was not as complex, resource intensive, or time consuming.⁵ Because of the complexity of the issues and broad congressional interest and requests, we have been assessing DOD's planning for the reposturing effort since August 2007, under the authority of the Comptroller General to conduct evaluations at his own initiative. Specifically, our objectives were to determine (1) the extent to which logistical planning for the reposturing of U.S. forces from Iraq has begun and the assumptions upon which it is based, and (2) DOD has established roles and responsibilities for managing and executing the retrograde of materiel and equipment from Iraq. In addition, we identified several issues that DOD will need to consider as it develops a comprehensive plan for reposturing U.S. forces from Iraq.

To determine what planning has been done regarding the potential reposturing of forces from Iraq and upon what assumptions DOD has based its plans, we reviewed relevant documents, to include command briefings and in-progress reviews, orders, and staff analyses that we obtained from several DOD organizations including U.S. Central Command (CENTCOM), MNF-I, and U.S. Army Central (ARCENT).⁶ We also interviewed officials who were directly involved in the logistical planning efforts to determine the status and scope of these efforts. We also traveled to Kuwait in May 2008 and met with DOD officials from a variety of organizations who participated in a logistical summit held at Camp Arifjan, Kuwait. We also obtained copies of the briefings and the logistical reposturing order that resulted from this summit. Based on these discussions as well as the documents we obtained, we were able to determine the assumptions upon which the planning effort was based.

⁴We focused our review primarily on the Army because it has the largest logistical footprint in Iraq. The majority of units, materiel, and equipment in the Iraqi theater belong to the Army with relatively few additional services' units, materiel, and equipment. Marine Corps officials told us that the Marines will use Army logistics systems and pipeline to enter and exit the Iraqi theater. In addition, DOD officials have stated that the Air force and Navy have negligible logistical footprints in Iraq.

⁵Discussion with DOD officials in Kuwait indicated that the capacity of the base infrastructure in Kuwait to temporarily house and out-process personnel could be rapidly expanded with 30 days notice. Moreover, during unit redeployments the majority of personnel from each redeploying unit are quickly moved to the United States, leaving only a small stay-behind detachment to manage the retrograde of unit equipment.

⁶For a listing of all the organizations visited during the course of this engagement see app. I.

To determine the extent to which DOD has established roles and responsibilities for managing and executing the retrograde of materiel and equipment from Iraq, we reviewed and analyzed briefings, e-mail correspondence, orders, joint and Army doctrine, relevant sections of the U.S. Code, and other data obtained from DOD organizations in both the United States and Kuwait. These officials provided us with information about the way the retrograde process is supposed to work as well as any challenges they have encountered. While in Kuwait, we also visited locations at which various aspects of the redeployment and retrograde process are performed and spoke with local commanders and on-site supervisors about their experiences and challenges.

During the course of this engagement we identified several issues that DOD will need to consider as it develops a comprehensive plan for reposturing U.S. forces from Iraq. We identified these issues by reviewing our past work as well as documents we obtained from various defense commands and activities, including staff analyses, briefings, orders, doctrinal publications, and relevant laws and regulations. The officials we spoke with included commanders and staff officers who had direct knowledge of the issues we identified. Moreover, we visited several locations in both the United States and Kuwait where the issues we identified would have an impact and, while there, we discussed the possible ramifications of these issues with local DOD officials.

We conducted our audit from August 2007 through August 2008 in accordance with generally accepted government auditing standards. Those standards require that we plan and perform the audit to obtain sufficient, appropriate evidence to provide a reasonable basis for our findings and conclusions based on our audit objectives. We believe that the evidence obtained provides a reasonable basis for our findings and conclusions based on our audit objectives. Appendix I includes more detailed information on our scope and methodology.

Results in Brief

While the pace and overall extent of reposturing in Iraq has yet to be determined, various defense commands began planning for reposturing in fall 2007, and in May 2008 DOD began coordinating these individual planning efforts to develop a logistical framework based on three key assumptions. According to DOD officials, initial planning efforts were uncoordinated because the three organizations undertaking them—the Defense Logistics Agency (DLA), the Army Materiel Command (AMC), and Headquarters, Department of the Army—conducted their planning effort on their own initiative and with little input from CENTCOM and MNF-I,

the commands overseeing operations in Iraq. By late 2007, however, a move began to synchronize and coordinate the efforts of DOD organizations engaged in planning for a reposturing of U.S. forces in Iraq. This culminated in a May 2008 logistics summit at Camp Arifjan, Kuwait, and resulted in an order published by MNF-I that contained the process for the redeployment of units and retrograde of materiel and equipment. The order also established a working group chartered to continue the planning with an eye toward seeking solutions to challenges, including several of the challenges we discuss later in this report. DOD's planning efforts to date have been based on the following three key assumptions:

- any reposturing initiative will be based on MNF-I and Department of State assessments of conditions on the ground;
- there will be sufficient lead time to refine reposture plans once an order with a specific timetable and force posture in Iraq is issued; and
- the reposturing of forces will be deliberate and gradual, predicated on a 180-day process for units leaving Iraq and a sustained flow of no more than 2.5 brigades' worth of equipment and materiel out of Iraq each month.

Although efforts have begun to synchronize planning for reposturing, DOD, CENTCOM, and the military services have not clearly established roles and responsibilities for managing and executing the retrograde of materiel and equipment from Iraq. Joint doctrine states that unity of command must be maintained through an unambiguous chain of command, well-defined relationships, and clear delineation of responsibilities and authorities. However, although CENTCOM has designated an executive agent for the synchronization of the retrograde of materiel and equipment from the Iraqi theater of operations, no unified or coordinated structure exists to account for the role of a variety of teams and units engaged in retrograde operations, such as the disposition of excess property and maintaining accountability of major end items like tanks and High Mobility Multipurpose Wheeled Vehicles (HMMWV). This results in confusion and a lack of clarity on the ways those teams should be utilized. In addition, while the Army has designated ARCENT as its lead element for retrograde of Army material and equipment from the CENTCOM AOR, until recently ARCENT had no direct command authority over the two Army units responsible for the retrograde of the bulk of materiel and equipment in Iraq, a situation that resulted in inefficiency and significant amounts of materiel and equipment in Kuwait sitting idle and awaiting disposition instructions. Finally, another example of this lack of unity of command is that data systems used during the retrograde process

are incompatible. Although a fix for this data system incompatibility has been identified, the fix has not yet been implemented.

We identified several other issues that will affect the development of plans for reposturing U.S. forces from Iraq. Specifically, based on our discussion with DOD officials and analysis of planning efforts to date, the effectiveness and efficiency of DOD's redeployment of equipment and people will depend on the extent to which it develops plans that address and include:

- guidance for the management of hazardous materials and waste and the disposition of property, which could affect the time and cost of closing installations in Iraq;
- guidance and plans for reposturing of contractors from Iraq;
- accountability and disposition of contractor-managed government-owned property;
- the possibility of restrictive conditions on the use of facilities in Kuwait and other neighboring countries;
- availability of wash racks and the number of customs inspectors in Kuwait;
- capacity of military owned and operated transports and convoy security assets, including limits on the main supply route;
- increased demand for access to mental health care providers;
- infrastructure requirements of returning units; and
- requirements for training and equipment reset to restore readiness.

DOD has begun to address these issues. For example, it is addressing the accountability of contractor-managed property and increasing the number of mental health providers. The National Defense Authorization Act for Fiscal Year 2008 requires DOD to brief the congressional defense committees on certain matters that were to be addressed, to the extent practicable, in the President's report. These matters include an assessment of U.S. force levels required in Iraq, the missions they will undertake in Iraq, the incremental costs or savings of any proposed changes to such levels or missions, and a description of the range of conditions that could prompt changes to the levels of U.S. forces required in Iraq, including the status of planning for such changes to the levels or missions of U.S. forces in Iraq. However, certain issues we have identified above are not specifically covered by this requirement.⁷ We believe that more specific

⁷National Defense Authorization Act for Fiscal Year 2006, Pub. L. No. 109-163, § 1227 (2006) (as amended by the National Defense Authorization Act for Fiscal Year 2008, Pub. L. No. 110-181, § 1223 (2008)).

reporting from DOD on these issues and DOD's mitigation plans related to these issues will enable Congress to better exercise effective oversight of DOD's plans.

In light of our observations, to ensure that DOD can efficiently and effectively retrograde its materiel and equipment from Iraq, we recommend that the Secretary of Defense, in consultation with CENTCOM and the military departments, take steps to clarify a unified or coordinated chain of command over logistical operations in support of the retrograde effort. We also recommend that the Secretary of Defense, in consultation with the military departments, correct the incompatibility weaknesses in the various data systems used to maintain visibility over equipment and materiel while they are in-transit. Further, to enhance its ability to exercise its oversight responsibilities, Congress may wish to consider directing DOD to modify its briefings submitted in accordance with the National Defense Authorization Act for Fiscal Year 2008 to include specific details on the status of its reposturing planning and how it intends to mitigate issues such as those we identified in this report.

In written comments on a draft of this report, DOD partially concurred with the first recommendation and fully concurred with the second recommendation. The department also provided a number of general comments and technical comments that we considered and incorporated, as appropriate. The department's comments and our evaluation of those comments are discussed in detail in a later section of this report. A complete copy of DOD's written comments, including the department's general and technical comments and our evaluation of each of those comments, is included in appendix II.

Background

According to DOD officials, U.S. forces in Iraq will not be "drawn down" but rather "repostured." MNF-I defines "reposture operations," a non-doctrinal term, as "the realignment of forces, basing, and resources to adjust to changes in the operating environment."⁸ Joint doctrine, as outlined in DOD's joint publications for both operations and planning emphasizes the importance of end-state planning and planning for the termination of combat operations. Inherent in DOD's reposture planning is the concept of redeployment, which joint doctrine defines as "the transfer of forces and materiel to support another joint force commander's operational requirements, or to return personnel, equipment, and materiel

⁸Annex E to MNF-I FRAGO 08-232, *Logistics Reposture Guidance* (May 28, 2008).

to the home and/or demobilization stations for reintegration and/or out-processing.”⁹ Associated with redeployment is another non-doctrinal concept—retrograde.¹⁰ As of May 2008 there was no agreed-upon definition for retrograde as it applies to reposture planning. However, according to some of the proposed definitions the term generally refers to the evacuation of materiel and equipment from Iraq. Moreover, our analysis of DOD documents indicates that the terms “retrograde” and “redeployment” are often used interchangeably. For clarity we use the term “redeployment” to refer to the movement of units (including a unit’s complement of personnel, equipment, and materiel) and “retrograde” when referring to the movement of materiel and equipment.

Our analysis of previous GAO reports and testimonies on Operations Desert Shield and Desert Storm indicated that retrograde of materiel and equipment would consume the most time and resources throughout the reposturing effort.¹¹ Since the 1990s, we have identified DOD’s supply chain management as a high-risk area, because DOD has been unable to consistently meet its goal of delivering the “right items to the right places at the right time.” Since 1991, we have issued a number of reports highlighting weaknesses in DOD’s supply chain management throughout Operations Desert Shield and Desert Storm and Operation Iraqi Freedom.¹²

The logistics infrastructure that supports the redeployment and retrograde effort in the Iraqi theater of operations is large and complex, consisting of

⁹Joint Publication 1-02, *DOD Dictionary of Military and Associated Terms* (May 30, 2008).

¹⁰The terms “retrograde movement,” “retrograde operation,” and “retrograde personnel” are doctrinal terms defined in JP 1-02. However, these definitions do not apply to the way in which the term “retrograde” is being used by logistics planners with regard to the reposture planning.

¹¹See GAO Operation Desert Storm: DOD’s Funding Actions Relating to Leftover Inventories, [GAO/NSIAD-93-143FS](#) (Washington, D.C.: Apr. 26, 1993); Materiel Disposal: Alleged Improper Disposition and Destruction of Serviceable Materiel and Supplies in Saudi Arabia, [GAO/NSIAD-93-139R](#) (Washington, D.C.: Mar. 11, 1993); Operation Desert Storm: Lack of Accountability Over Materiel During Redeployment, [GAO/NSIAD-92-258](#) (Washington, D.C.: Sept. 23, 1992); and Desert Shield/Storm Logistics: Observations by U.S. Military Personnel, [GAO/NSIAD-92-26](#) (Washington, D.C.: Nov. 13, 1991).

¹²See GAO, Desert Shield and Desert Storm Reports and Testimonies: 1991-93, [GAO/NSIAD-94-134W](#) (Washington, D.C.: Mar. 1994); *Defense Logistics: Preliminary Observations on the Effectiveness of Logistics Activities during Operation Iraqi Freedom*, [GAO-04-305R](#) (Washington, D.C.: Dec. 18, 2003); and *Defense Logistics: Actions Needed to Improve the Availability of Critical Items during Current and Future Operations*, [GAO-05-275](#) (Washington, D.C.: Apr. 8, 2005).

military organizations that operate in both Iraq and Kuwait, and it is through Kuwait's three seaports and two airports that the vast majority of U.S. forces, materiel, and equipment flow out of the theater of operations. Moreover, there are myriad logistics organizations in both Iraq and Kuwait that also support these operations, including elements CENTCOM, U.S. Transportation Command, DLA, ARCENT, the 1st Theater Sustainment Command, AMC, U.S. Marine Corps Central Command, U.S. Naval Forces Central Command, U.S. Air Forces Central Command, and U.S. Special Operations Command Central.

In this report we examine certain components of the logistics infrastructure that support the redeployment and retrograde effort as well as certain aspects of the redeployment and retrograde processes. To properly frame this discussion, however, it is necessary to have some sense of the size of the force in Iraq and the logistics activities in Kuwait that support the redeployment and retrograde of this force. (Figure 1 shows the locations of select installations in Iraq and key logistics activities in Kuwait.) For example, although public discussion of the size of the U.S. force in Iraq generally emphasizes the number of brigade combat teams, according to DOD officials as of May 2008 there were the equivalent of 47 brigades' worth of materiel and equipment in Iraq spread over some 311 installations of varying size. The majority of this materiel and equipment, some 80 percent according to DOD officials, is theater provided equipment, approximately 582,000 pieces of equipment worth about \$15.5 billion. Theater provided equipment is permanent stay behind equipment consisting of specific line items of modified table of organization and equipment property, issued Army prepositioned stocks, and items purchased specifically for Operations Iraqi Freedom that remain in Iraq. The 582,000 pieces of equipment include all the accountable line items on the property books for the theater provided equipment such as up-armored HMMWVs, Mine Resistant Armored Program Vehicles, other wheeled and tracked vehicles, generators, body armor, and technologies used to counter improvised explosive devices. In addition, as of summer 2007 there were more than 60,000 materiel containers in Iraq and over 127,000 short-tons of ammunition in Iraq and Kuwait.

Figure 1: Select Installations in Iraq and Key Logistics Activities in Kuwait

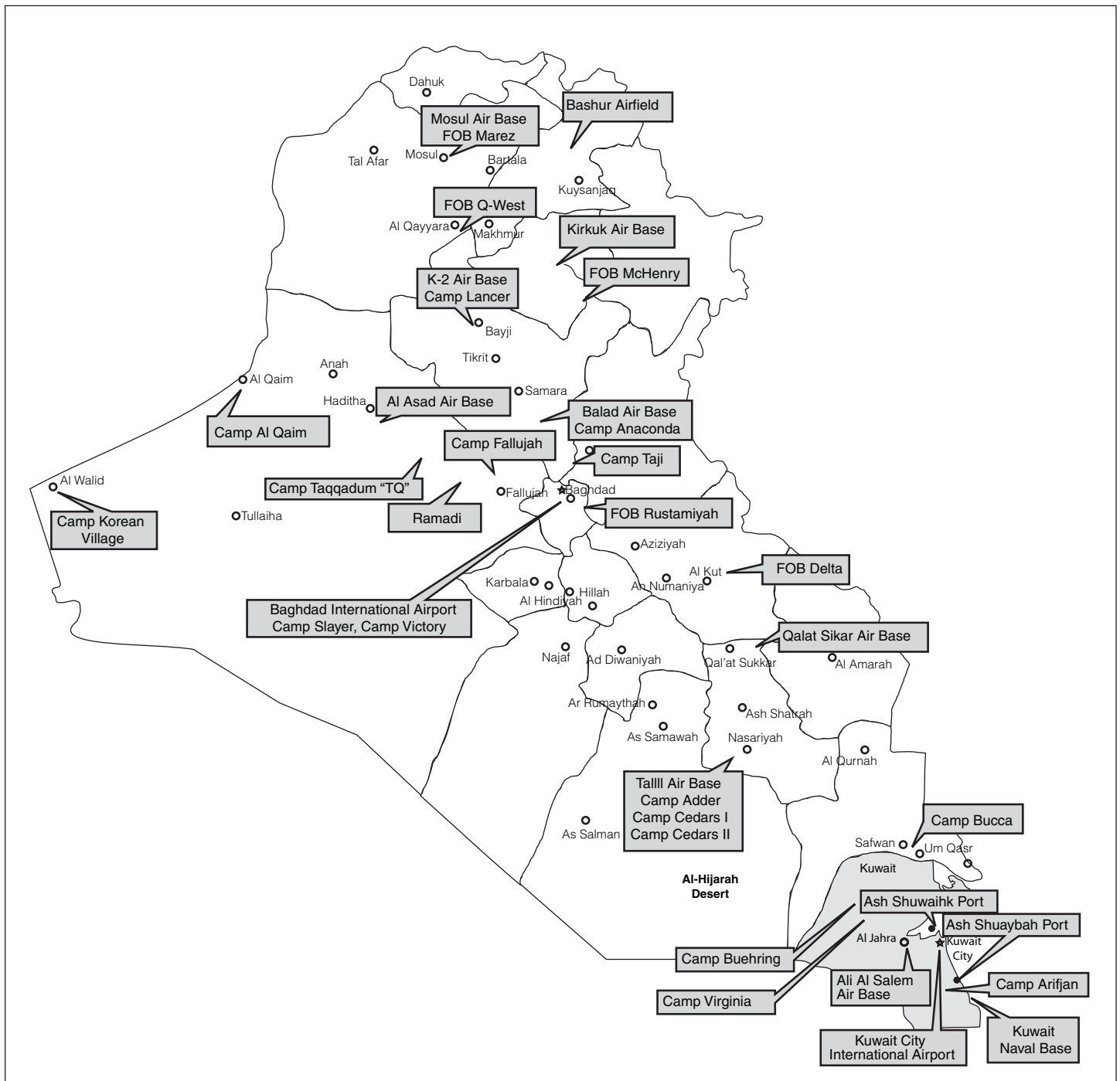

Sources: GAO, Art Explosion, and GAO analysis of Stars and Stripes and DOD data.

Planning Efforts, Begun in Fall 2007 and Coordinated in 2008, Are Predicated on Three Key Assumptions

While various individual defense commands began planning for the reposturing of postsurge forces from Iraq in the fall of 2007, those planning efforts were not coordinated until May 2008 and were based on three key assumptions. At the outset these planning efforts were uncoordinated and lacked a joint perspective. However, in late 2007, an effort was begun to synchronize the planning efforts of various DOD organizations as they related to reposture operations in the Iraqi theater of operations. The result of this effort was a series of logistics synchronization conferences as well as MNF-I's publication of a logistics reposture order in May 2008.

Reposture Planning Began Fall 2007 but Initial Efforts Were Uncoordinated

In the fall of 2007 three DOD organizations—AMC, DLA, and Headquarters, Department of the Army (HQDA)—began separate planning initiatives designed to deal with issues relating to the retrograde of materiel and equipment from Iraq. As part of their planning processes, each of the three organizations established working groups or forums for subordinate entities to communicate about issues arising from their planning. Despite working on the same broad set of issues, however, there was little coordination among the three organizations. Moreover both CENTCOM, the combatant command whose area of responsibility includes Iraq and Kuwait, and MNF-I, the headquarters responsible for operations in Iraq, provided little input and guidance to these efforts.

Army Materiel Command officials told us that they issued a warning order on September 6, 2007, directing its subordinate units to be prepared to develop plans in support of the transition from current operations to the reduction of forces in Iraq. The warning order established a biweekly video teleconference, which first met on September 14, 2007, as a forum for all AMC units and staff to discuss upcoming requirements in support of Iraqi theater reposturing efforts. Moreover, the command also stood up a Theater Drawdown Working Group. The original intent of this working group was to conduct a mission analysis of what it would take to redeploy multiple brigade combat teams quickly; however, by November 2007 the working group became an umbrella organization that synchronized AMC's various planning efforts in support of a reposturing of forces from Iraq. Among the issues AMC and its subordinate organizations explored were the capacities of its depots, the disposition of excess equipment in the Iraqi theater of operations, additional resources that might be required in theater based on the pace of the unit redeployments, rebuilding Army Prepositioned Stocks in theater, AMC capabilities in theater to support the reposturing effort, identifying what AMC support was required for reducing the number of installations in theater, and identifying the need for changes in contracts or additional funding.

According to Defense Logistics Agency officials, their agency established a Retrograde Task Force in September 2007 when it became clear that DOD was looking at the reposturing of forces in Iraq.¹³ The mission of the Retrograde Task Force was to plan and coordinate the execution of DLA actions in support of retrograde operations from Operation Iraqi Freedom. It was also to develop an integrated support plan for those operations by December 2007. The Retrograde Task Force canvassed DLA's customers—such as the military services, CENTCOM, and ARCENT—to gather data on their respective roles and responsibilities for a reposturing effort and conducted a mission analysis to coordinate and anticipate future DLA actions and identify gaps and seams in the overall retrograde effort.

Headquarters, Department of the Army issued its guidance for the retrograde of materiel from the CENTCOM area of responsibilities on October 23, 2007. HQDA designated ARCENT as the Army's "lead element for retrograde" of Army material and equipment from the CENTCOM AOR, but also stated that AMC is "responsible for executing HQDA retrograde policy." The order provided a set of business rules—by class of supply¹⁴—that all Army units, commands, and agencies involved in the retrograde process in the CENTCOM area of responsibility were to follow. It also provided disposition instructions for these classes of supply. Finally, the order also established a monthly video teleconference, hosted by the HQDA, G-4 (Logistics), to provide a forum in which issues and obstacles affecting retrograde operations could be discussed.

Although these DOD organizations made efforts to synchronize their planning—for example, both AMC and DLA participated in Headquarters, Department of the Army's monthly video teleconferences and DLA identified Service headquarters as "external links" to its Retrograde Task Force—there was, according to DOD officials, little coordination among the separate retrograde planning efforts. In particular, while AMC and HQDA focused solely on the retrograde of Army materiel and equipment, other DOD officials felt a joint approach headed by either the Joint Staff or CENTCOM was required. Moreover, CENTCOM and MNF-I provided little guidance; according to officials from CENTCOM, they were waiting on

¹³ According to DLA officials, although organization of the Retrograde Task Force began in late summer 2007, the Retrograde Task Force was not officially active until September 10, 2007.

¹⁴ DOD classes of supply, and what is included in each class of supply, are laid out in app. III of this report.

input from MNF-I while according to officials representing MNF-I, all discussion of reposturing was “close hold” in that headquarters until after the MNF-I commander’s congressional testimony in April 2008.

Reposture Planning Coordinated by May 2008

The synchronization of planning efforts by various defense commands for reposturing of post-surge forces began in late 2007, but was not coordinated until May 2008. According to DOD officials, by late 2007 it had become clear that not only were the various reposturing planning efforts uncoordinated and lacking a joint focus, but the perspectives of organizations in the United States differed from those of organizations in the Iraqi theater of operations. To rectify this, senior DLA officials met with their counterparts in CENTCOM and MNF-I to discuss means by which reposture planning could be better coordinated and more inclusive. Recognizing the added value of a more inclusive and coordinated planning effort, CENTCOM and MNF-I officials invited DLA to embed members of its Retrograde Task Force inside logistics organizations in Kuwait and Iraq. This action established an in-theater planning cell embedded in the organizations involved with logistical planning for reposturing within the Iraqi theater of operations. These organizations included MNF-I, Multi-National Corps, Iraq, ARCENT, the 1st Theater Sustainment Command, the CENTCOM Deployment and Distribution Operations Center, and the 401st and 402nd Army Field Support Brigades.

As a result of these efforts, coordination among DOD organizations involved in redeployment and retrograde planning increased. For example, when representatives from DLA arrived in Iraq and Kuwait they discovered that CENTCOM and ARCENT were holding separate retrograde video teleconferences; these were eventually merged into one joint video teleconference. In addition, although the major focus had been on Army retrograde processes because the Army has the largest ground presence in the theater, once a coordinated reposture planning effort was undertaken other services got involved in the redeployment and retrograde planning process as well.

The end result of the increased coordination and synchronized planning among the organizations involved with reposture planning for Iraq was a logistics summit held at Camp Arifjan, Kuwait, from May 4-9, 2008. At this summit the logistics processes for the retrograde of all classes of supply were synchronized, discussions about what to do with contractor-acquired, government-owned property were held, and general and flag officers were briefed. Representatives from CENTCOM, U.S. Transportation Command, DLA, MNF-I, MNC-I, ARCENT, the 1st Theater

Sustainment Command, HQDA, and the Navy, Marine Corps, Special Operations, and Air Force component commands in theater attended the summit. Based on the summit, MNF-I finalized and published its overarching guidance for logistics reposturing operation on May 28, 2008. This order defined retrograde disposition processes for each class of supply within the Iraqi theater of operations, codified a 180-day unit redeployment template, and addressed basing.¹⁵ Moreover, the order also established a Logistics Reposture Working Group¹⁶ and assigned the group three key tasks:

- Analyze the allocation of resources available to execute the logistics reposturing processes to identify potential shortfalls and to address synchronization issues between various operational and strategic entities.
- Review limitations, constraints, and risks associated with the logistics reposturing processes and develop mitigation measures.
- Review after action report issues from unit redeployments and base reposturing in order to identify policy and procedural gaps and inconsistencies.

Assumptions Guiding Reposture Planning

Based on GAO analysis as well as discussion with DOD officials, both the May 2008 conference and the subsequent logistics reposture order were based on three assumptions. The first is that any reposturing initiative will be based on MNF-I and Department of State assessments of conditions of the ground. The second is that there will be sufficient lead time to refine the plans for reposturing once an order with a specific timetable and force posture in Iraq is issued. The third is that the reposturing of forces will be deliberate and gradual, predicated on a 180-day redeployment template for units leaving Iraq and a model that states the theater logistics infrastructure can sustain the deployment and redeployment of no more than a total of five brigades' worth of equipment and materiel in and out of Iraq, per month.

¹⁵Basing options include a base's closure, a transfer to the government of Iraq, or a "shrink and share" of a base where both Iraqis and Coalition forces collocate in a landlord-tenant relationship.

¹⁶The Logistics Reposture Working Group is an enduring forum with all key logistics organizations in the Iraq and Kuwait theater. It meets monthly and addresses strategic, operational, and theater-level logistics issues. It assigns Offices of Primary Responsibility or Operational Planning Teams to develop solutions to logistics-related issues.

The MNF-I 180-day template, summarized in table 1, details the actions U.S. Army and Marine Corps units must complete 180 days prior to the unit's available-to-load date.¹⁷ Twenty-two total organizations—17 separate theater entities plus 5 additional property and retrograde support teams—participate in this process.¹⁸

Table 1: Multi-National Forces-Iraq 180-day Template

Number of days before departure	Actions
180 to 160	ID types of equipment, request disposition and plan coordination with all retrograde teams
150 to 100	Finalize any early reset plans, set deployment timeline
100 to 80	Disposition instructions issued, request and authorize donation authority
80 to 60	Schedule strategic transportation
60 to 40	Order containers, dispose of excess supplies, develop detailed movement plan, schedule wash racks
40 to 20	Move excess vehicles, validate movement of people
20 to 0	Complete customs and agriculture inspections, move equipment from wash racks to sterile yard to marshaling yard to pier to ship

Source: GAO analysis based on MNF-I FRAGO 08-232.

In addition to the 180-day redeployment template, logistics planners in the Iraqi theater of operation assume the theater's logistics infrastructure can sustain a flow of approximately 2.5 brigades' worth of materiel and equipment into and out of Iraq each month based on a rate-of-flow model they have created. (See appendix V for a more detailed discussion of this model). This model takes into consideration historical property book data, the number of convoys that can be run each month, and the average time it takes a unit to clean its equipment and clear customs in Kuwait. However, according to DOD officials and GAO analysis, while this rate-of-flow model may be a useful planning tool, it should not be used to predict how long it would take to retrograde all the equipment and materiel in Iraq. One reason for this is the actual amount of equipment and materiel with which any one brigade will redeploy varies and these amounts directly affect the number of convoys required to move the unit and the amount of time it will take the unit to clean its equipment before it can be retrograded. For example, during the summer of 2008 the average heavy brigade combat team redeployed with significantly less equipment and materiel than

¹⁷The available-to-load date is the period of time in which a unit's materiel and equipment is ready to be loaded at a sea or airport.

¹⁸See App. IV for a list of the support teams and their higher headquarters.

projected in the model because the unit used a large amount of theater provided equipment that remained in Iraq when it redeployed. Moreover, GAO has identified several issues, explained in detail later in this report, that may affect both the volume and pace at which materiel and equipment can flow through the retrograde pipeline. Several of these issues are not currently accounted for by the model.

Executive Agent for Retrograde of Materiel and Equipment Lacks Necessary Authority

Despite recent initiatives to synchronize and coordinate the planning efforts of DOD organizations with regard to the reposturing of forces from Iraq, clear roles and responsibilities with regard to managing and executing the redeployment and retrograde process have not yet been established. According to joint doctrine, “unity of command must be maintained through an unambiguous chain of command, well-defined command relationships, and clear delineation of responsibilities and authorities.”¹⁹ Combatant commanders exercise “authoritative direction over logistics,” and may organize logistics resources within theater according to operational needs.²⁰ CENTCOM’s retrograde order designates an executive agent for the synchronization of retrograde operations in Iraq. At the same time, because each military department has unique authorities and roles, including the requirement to provide logistical support to its own assigned forces, CENTCOM efforts to establish a truly unified command structure with respect to logistics may be complicated.²¹ With no unified or coordinated structure to account for the roles of the theater property and retrograde support teams that assist units with the retrograde of material and equipment, there is confusion and a lack of clarity about how these teams should be utilized. In addition, while the Army has designated ARCENT as its lead element for retrograde of Army material and equipment from the CENTCOM AOR, until recently ARCENT did not have direct command authority over the two Army units in the theater responsible for retrograding the vast bulk of the equipment in Iraq. Because of this the retrograde process was inefficient and resulted in significant amounts of theater provided equipment sitting idle in Kuwait awaiting disposition instructions. Finally, based on GAO analysis, a significant manifestation of the lack of unity of command over the

¹⁹Joint Publication 1, *Doctrine for the Armed Forces of the United States*, IV-19 (May 14, 2007).

²⁰Joint Publication 4-0, *Joint Logistics*, V-2 (July 18, 2008).

²¹Joint Publication 4-0 notes that “the joint logistician will rarely have unity of joint logistics command, and subsequently control of joint logistics is more challenging.”

retrograde process is the use of incompatible data systems. Although a fix for this incompatibility has been identified, the implementation of the fix has not been enforced.

No Single Organization Has Authority over Theater Property and Retrograde Support Teams

No single organization has command authority over all of the theater property and retrograde support teams that facilitate the redeployment and retrograde process. According to ARCENT, the lack of unity of command over these teams makes their use unclear and confusing. There are 10 theater property and retrograde support teams that assist units with redeployment and the retrograde of material and equipment.²² ARCENT has tactical control authority over only 2 of these teams, the Mobile Redistribution Team and the Redistribution Property Assistance Team.²³ The Mobile Redistribution Team assists redeploying units with identifying, documenting, and providing disposition instructions for excess supplies and repair parts in order to reintegrate required supplies into the distribution pipeline. The Redistribution Property Assistance Team is focused primarily on accountability, turn-in, and retrograde of theater provided equipment. Of the remaining 8 theater property and retrograde support teams, 2 report to AMC, 2 report to MNC-I, and 1 each report to U.S. Transportation Command, the Surface Deployment and Distribution Command, DLA, and the Marine Corps Logistics Command. Each of these 8 teams also provides redeploying units with essential services and expertise. For example, the Joint Redeployment Support Team, which reports to U.S. Transportation Command, has the mission of supplying customs, disposition, hazardous material, and transportation expertise to redeploying units and is to enable in-transit visibility over a unit's materiel and equipment from its forward operating base to the unit's home station or to an identified depot. Another team, the Inventory Property Assistance Team, reports to MNC-I. The Inventory Property Assistance Team's mission is to track material and equipment shortages and excesses for units in Iraq and, when a unit is redeploying, provide instructions for either the redistribution or retrograde of that unit's material and equipment. It has the added mission of conducting inventories during the

²²See App. IV for a complete list of the theater property and retrograde support teams.

²³ARCENT has tactical control over Task Force 586, which is the headquarters that controls these units. This allows ARCENT to control and direct these assets through Task Force 586. However, Army Materiel Command also exercises some control over the RPAT because the RPAT supports the 402nd Army Field Support Brigade, over which AMC has command authority through its subordinate command, Army Sustainment Command.

closure of forward operating bases, conducting the transfer of government-furnished equipment,²⁴ and conducting inventories of “found” equipment containers in Iraq. ARCENT has proposed a command structure within MNF-I and MNC-I to coordinate command and control over the assistance teams in order to better synchronize retrograde efforts in the theater, but as of May 2008 this structure has not been adopted. As a result, according to ARCENT, the use of the various teams during the retrograde process is both unclear and confusing.

Until Recently No Theater Logistical Organization Had Command Authority over Units Responsible for the Retrograde of Most Equipment in Theater

Until recently, there was no single theater logistical organization with command authority over the two units responsible for retrograding theater provided equipment, which accounts for 80 percent of the equipment in Iraq. As a result significant amounts of theater provided equipment were sitting idle in Kuwait awaiting disposition instructions. The two units responsible for retrograding theater provided equipment are the 402nd Army Field Support Brigade in Iraq and the 401st Army Field Support Brigade in Kuwait. Together, these field support brigades relieve redeploying units of accountability for theater provided equipment, arrange for its transportation from Iraq to Kuwait, and process the equipment through the wash racks, customs, and on to its designated destination. According to emerging Army doctrine (currently in draft), when Army field support brigades are deployed in support of a contingency mission to an operational theater and when directed by higher authority, they will fall under the operational control of a theater or expeditionary sustainment command.²⁵ According to joint doctrine,²⁶ a theater sustainment command is the logistics command and control element assigned to the Army Service Component Command and is the single Army logistics headquarters in a theater of operations. Theater sustainment commands may also employ one or more expeditionary sustainment commands to aid them with command and control.

Prior to June 2008 in the Iraqi theater of operations, neither ARCENT—CENTCOM’s Army Service Component Command and Army’s designated lead element for retrograde operations in the theater—nor ARCENT’s

²⁴Government-furnished equipment is equipment provided to a contractor for use in fulfilling the terms of a contract. This equipment is maintained by the contractor and returned to the government at the contract’s conclusion and/or termination.

²⁵FM 4-93.41, *Army Field Support Brigade Operations*, Initial Draft, (May 1, 2008).

²⁶JP 4-0, *Joint Logistics* (July 18, 2008).

subordinate theater and expeditionary sustainment commands had any direct command authority over the 401st or 402nd Army Field Support Brigades. Instead, higher headquarters for both the field support brigades was the Army Sustainment Command located at Rock Island Arsenal, Illinois.²⁷ This command relationship appeared to be inconsistent with emerging Army doctrine and Joint doctrine, and HQDA had apparently denied ARCENT authority over all Army organizations in the CENTCOM AOR that support the retrograde process, including the 401st and 402nd. In an effort to provide some in-theater oversight for the retrograde process, AMC has designated the ARCENT G-4 as the commander, Army Materiel Command, southwest Asia (AMC-SWA). However, like ARCENT and its theater and expeditionary sustainment commands, this commander had no direct command authority over the field support brigades whose actions he is charged to synchronize and oversee. Moreover, he did not have a staff to assist him in his duties aside from a chief of staff. According to CENTCOM officials, in June 2008 CENTCOM designated ARCENT as having operational control over the 401st Army Field Support Brigade and the 402nd Army Field Support Brigade. While CENTCOM's action may result in changes in the retrograde process for transferring theater provided equipment from Iraq to Kuwait, we have not yet evaluated the effect of this change.

Before this change occurred, the lack of unity of command made the process for transferring theater provided equipment from Iraq to Kuwait inefficient and resulted in significant amounts of this equipment sitting idle in Kuwait awaiting disposition instructions. This was because the headquarters with the authority to coordinate the theater provided equipment retrograde process (Army Sustainment Command) lacked visibility over the process while the headquarters with visibility over the process (AMC-SWA) lacked the command authority and the staff to coordinate the actions of the field support brigades that execute the process. For example, on May 16, 2008, 177 pieces of theater provided equipment rolling stock²⁸ that were no longer needed in theater were sitting idle in Kuwait awaiting disposition instructions, some since March

²⁷ Army Sustainment Command is a subordinate organization to Army Materiel Command and is responsible for field support, materiel management, contingency contracting, and Army pre-positioned stocks.

²⁸ Class VII Items are further divided into rolling stock and nonrolling stock. Rolling stock includes wheeled vehicles, tracked combat vehicles, wheeled/tracked construction equipment, trailers, semitrailers, and standard trailer-mounted equipment such as generators. Nonrolling stock includes all class VII items not classified as rolling stock.

2008. Army Sustainment Command took no actions to rectify this situation and the commanding general, AMC-SWA, who is also the ARCENT G-4, did not have authority to direct that action be taken. Instead, he used his personal contacts with DOD officials in the United States to obtain the needed disposition instructions. Despite these actions, however, problems persisted with the retrograde process. For example, a DOD official in Kuwait provided documentation showing that over 2,100 non-rolling stock items of theater provided equipment—including such items as 120mm mortars, gun mounts, radio sets, and generators—were also sitting idle in Kuwait awaiting disposition instructions.

Logistical Organizations Have Not Enforced or Lack the Authority to Enforce Improvements to the Retrograde Process

One significant manifestation of the lack of unity of command is that logistical organizations have not enforced or lack the authority to enforce improvements to a retrograde process that is slow and does not maintain in-transit visibility. ASC has identified a solution to the problem and ordered its implementation, but it has not enforced its order despite having the authority to do so. Until recently, ARCENT lacked the necessary authority over the field support brigades to enforce Army Sustainment Command's solution. As a result, significant stores of TPE that are no longer needed in theater are sitting idle in Kuwait awaiting disposition instructions.

Retrograde Process for Certain Theater Provided Equipment Is Slow and Does Not Maintain In-Transit Visibility

The current process for retrograding theater provided equipment no longer needed in Iraq is lengthy and does not maintain in-transit visibility.²⁹ This is caused by the frequent manual manipulation of data. According to DOD's Supply Chain Materiel Management Regulation, all DOD components shall structure their materiel management to provide responsive, consistent, and reliable support to the warfighter (customer) during peacetime and war using DOD standard data systems that provide timely, accurate in-transit asset information.³⁰

Currently, when theater provided equipment moves to Kuwait the 401st Army Field Support Brigade undertakes two concurrent manual processes to establish accountability and visibility for the equipment. Accountability is established by manually entering equipment data into one system, while

²⁹A detailed explanation of the systems and organization involved in this process is contained in App.VI.

³⁰See *DOD Supply Chain Materiel Management Regulation* Chapter 1, DOD 4140.1-R, § C1.3.1.1; § C1.3.1, § C1.3.2 and § C5.8, (May 23, 2003).

a second manual entry is made in a different system to provide visibility over each item by serial number. The visibility system, however, is a nonstandard Army information system. DOD guidance states that the DOD components should execute a supply chain strategy that promotes the use of shared common data and that wherever possible, adopt commercial data exchange and user interface standards and procedures while ensuring interoperability.

Once accountability and visibility over theater provided equipment has been established, personnel from the 401st Army Field Support Brigade request disposition instructions. This labor-intensive manual process involves sending spreadsheets populated with equipment data from Kuwait to Army Sustainment Command headquarters in Rock Island, Illinois, and then on to the specific Life Cycle Management Command³¹ responsible for each particular item, which, in turn, sends disposition instructions back through this chain to the 401st. This process can take months because of the manual workarounds used to pass and manipulate the data.

While equipment can be shipped once disposition instructions are received in Kuwait, in-transit visibility of the equipment is temporarily lost during shipment because the process used to direct shipment of the equipment—called Inter-Depot Transfer—bypasses the Global Transportation Network, DOD’s system for providing near real-time in-transit visibility information. This lack of in-transit visibility is contrary to current DOD guidance that requires timely, accurate in-transit asset information be available to all users and logistics managers and in a standard format adequate to satisfy needs.

The 401st Army Field Support Brigade uses another manual process to compensate for this lack of in-transit visibility by coordinating with Surface Deployment and Distribution Command elements at Kuwaiti ports in order to obtain final load manifests for each vessel. The manifest is forwarded to item managers in the United States so they can prepare to receive the equipment; however, manifest information does not reach the brigade until 24 to 48 hours after a vessel sets sail.

³¹The Army Materiel Command has five Life Cycle Management Commands, each of which is responsible for certain types of equipment. They are: Aviation and Missile, Chemical Materials Agency, Communications-Electronics, Joint Munitions & Lethality, and Tank-automotive & Armaments Command.

Logistical Organizations Have Not Enforced or Lack the Authority to Enforce Compliance with Orders to Implement Improvements to the Retrograde Process

Army Sustainment Command has stated that “the current process used...to manage and obtain disposition is slow and cumbersome with a high potential to be overwhelmed if reposturing is accelerated.” In addition to the more than 2,100 pieces of nonrolling stock TPE awaiting disposition instructions cited above—some reportedly for years—a DOD official stated that in the past rolling stock has been sitting idle in Kuwait for anywhere from 3 to 9 months.

Although Army Sustainment Command has issued an order outlining changes to the retrograde process that corrects the problems we have identified, neither of the field support brigades in the Iraqi theater of operations have followed it. In April 2008, Army Sustainment Command issued an order directing the 401st and 402nd Army Field Support Brigades to use Property Book Unit Supply Enhanced transactions to transfer equipment between Iraq and Kuwait in order to maintain accountability and visibility.³² Moreover, the order directed that disposition instructions for all theater provided equipment not required in theater should be requested through the Standard Army Retail Supply System.³³ According to a DOD official this will allow the automated request of disposition instructions, thereby reducing the time necessary to receive the instructions. Moreover, the system will provide data to the Global Transportation Network, thereby improving in-transit visibility over equipment. However, for reasons that were not made clear, this order has not been implemented and Army Sustainment Command has not compelled the field support brigades to comply.

In January 2008, ARCENT, as the lead agent for retrograde, requested that Headquarters, Department of the Army delegate to ARCENT more authority over the retrograde process. Specifically, according to ARCENT officials, ARCENT requested that it be given authority to determine and issue disposition instructions and that it be given authority to direct all Army organizations in the CENTCOM area of responsibility that support the retrograde process. As of May 2008, ARCENT had not received these

³²Army Sustainment Command Operations Order 30-08, *Retrograde of Theater Provided Equipment (TPE)* (Apr. 18, 2008).

³³The Standard Army Retail Supply System is a Combat Service Support peacetime and wartime logistics Standard Army Management Information System that (1) performs the supply functions of ordering, receiving, storing, and issuing supplies; (2) supports supply management functions such as excess disposition and redistribution; and (3) offers improved communications and advanced automation functionality. One of its benefits is providing asset visibility at the Brigade Combat Team, Corps, theater, and national levels.

authorities. Until recently, ARCENT had no authority to direct the field support brigades to comply with Army Sustainment Command's order to fix the data incompatibility problem in theater. While CENTCOM's action designating ARCENT as having operational control over the support brigades may result in changes in the disposition instruction process, we have not yet evaluated the effect of this command change.

Issues That DOD Needs to Consider in Its Reposture Planning

We identified nine issues that will affect the development of plans for reposturing U.S. forces from Iraq. These nine issues are discussed, in detail, in the following sections. Although the pace and overall extent of a potential reposturing are uncertain, DOD has begun to address these issues. While DOD officials are not required to report specific information about these nine issues or possible mitigation plans related to these issues, as part of the briefings they are required to provide to the congressional defense committees,³⁴ we believe that without more specific reporting from DOD, Congress may not be able to effectively exercise oversight responsibilities of DOD's plans.

Time and Cost Estimates for Base Closures in Iraq

According to ARCENT officials, closing or handing over U.S. installations in Iraq will be time-consuming and costly, although time and costs are difficult to estimate without a bilateral agreement addressing base closures. As of May 31, 2008, 311 U.S. installations in Iraq will have to be closed or turned over to the Iraqis during a reposturing effort, depending on the scope of U.S. reposturing. According to ARCENT officials, experience has shown it takes 1 to 2 months to close the smallest platoon- or company-size installations, which contain between 16 and 200 combat soldiers or marines. However, Multi-National Corps-Iraq has never closed an installation the size of complex installations such as Balad Air Force Base, which contains approximately 24,000 inhabitants and has matured over 5 years, making accurate predictions about the time it will take to close them difficult. ARCENT officials estimate it could take longer than 18 months to close a base of that size, likening the process to shutting down and moving a small U.S. city.

³⁴National Defense Authorization Act for Fiscal Year 2006, Pub. L. No. 109-163, § 1227 (2006) (as amended by the National Defense Authorization Act for Fiscal Year 2008, Pub. L. No. 110-181, § 1223 (2008)).

According to DOD officials, time and costs are difficult to estimate without an agreement between the United States and Iraq on base closure, especially with regard to guidance of the management of hazardous materials and waste and the transfer of personal property.³⁵ ARCENT officials stated that both issues are traditionally addressed in Status of Forces Agreements; however, as of July 18, 2008, the United States and Iraq do not have such an agreement.³⁶ Hence, although CENTCOM guidance states that the base commander is responsible for the removal or remediation of all hazardous materials and waste, ARCENT officials stated that base commanders do not know to what extent they must remediate the waste, and therefore may have difficulty estimating the time and cost of cleaning installations. In addition, according to ARCENT officials, absent an agreement with Iraq on the disposition of personal property, “all bunkers, trenches, fighting positions, and force protection barriers... will be removed” in accordance with CENTCOM policy.

ARCENT officials asserted that, absent a bilateral agreement with Iraq addressing the base closure or hand-over process, the U.S. will have to negotiate the terms of closure for each base individually, which could potentially slow the base closing process. For example, ARCENT officials noted that since the owners or lessees of the land on which the installations currently reside include the Iraqi Ministries of Interior, Defense, and Justice, and other Iraqi national government entities as well as private individuals, property transfers would be complicated and time consuming. Moreover, ARCENT officials stated that in the absence of a bilateral agreement that provides guidance for the management of hazardous waste and materials, it is normal practice to follow the established guidelines for this management, which generally are more stringent and therefore potentially more costly and time consuming.

³⁵MNF-I defines personal property as any property than can be moved and reused without significant refurbishment or degradation from its intended purpose. Personal property includes government property (those items owned by services and components) and items owned by individuals. Examples include re-locatable buildings, window air conditioning units (not to include split air conditioning unit), generators, desks, chairs, computers, office supplies, cots, foot lockers, and clothing.

³⁶As of July 18, 2008, the U.S. and Iraqi governments were still negotiating the terms of their bilateral agreement, although the exact nature of the agreement was still being negotiated.

Uncertainties Regarding Plans for Contractors

From late 2007 through July 2008, planning for the reposturing of U.S. forces in Iraq did not include a theater-wide plan for the reposturing of contractors. According to MNF-I's May 2008 logistics reposture order, logistics planners were to coordinate with the Defense Contracting Management Agency (DCMA) to identify contractual issues associated with logistics reposture operations. But as of June 2008, DCMA officials stated that they were not aware of a theater-wide plan for the reposturing of contractors. In fact, according to DOD officials, CENTCOM contracting planners did not begin participating in planning for the reposturing operations until July 2008.

While there is no theater-wide plan, since May 2008 Army LOGCAP officials have been participating in theater-wide logistics reposturing planning. Reposture planning for LOGCAP is significant, given that it is the largest logistical support contract in Iraq. According to a DOD official, examples of such participation include LOGCAP personnel attending a series of logistics conferences held at Camp Arifjan, Kuwait in May 2008, working with logistics reposture planning teams in MNF-I and MNC-I, and participating in the Logistics Reposture Working Group. However, according to a DOD official responsible for coordinating LOGCAP planning efforts with reposturing planning efforts, challenges remain in the planning for the reposturing of LOGCAP contractor personnel. For instance, decisions about reposturing of these contractors are often made before requirements have been clearly identified and DOD officials responsible for planning the reposturing of these contractors do not receive timely and accurate information from the customers or units using these contracts.

Accountability and Disposition of Contractor-Managed Government-Owned Property

Maintaining accountability for and managing the disposition of U.S. government property under the control of contractors may present challenges to reposturing from Iraq. According to Defense Contract Management Agency officials, there is at least \$3.5 billion worth of contractor-managed government-owned property³⁷ in Iraq. According to the same officials, the largest portion of all contractor-managed government-owned property in Iraq, \$3.37 billion, falls under the LOGCAP, an Army program to provide contracted resources to support U.S.

³⁷For simplicity, we use the term contractor-managed government-owned property to incorporate all items which the contractor manages expressly to perform under the contract, including items given to the contractor by the government (government-furnished equipment), or acquired/fabricated by the contractor.

contingency operations. Examples of LOGCAP equipment include laundry and bath facilities, food service, sanitation, housing, maintenance, transportation, construction, and power generation and distribution. According to Defense Contract Management Agency officials, non-LOGCAP contractor-managed government-owned property falls into four main categories. These are the Air Force Contract Augmentation Program, selective programs under DOD's Joint Contracting Command-Iraq/Afghanistan, programs run by the Gulf Region Division of the Army Corps of Engineers, and hundreds of smaller programs run by individual U.S. government agencies. Defense Contract Management Agency officials reported that property in these four categories includes, but is not limited to, plant equipment and materiel to support various reconstruction efforts like the Iraqi Department of Public Works.

Several DOD organizations have already begun planning for the disposition of excess contractor-managed government-owned property from Iraq.³⁸ For example, in October 2007, the Deputy Under Secretary of Defense for Logistics and Materiel Readiness increased the donation threshold for all excess U.S.-owned personal property in Iraq from \$5,000 to \$10,000³⁹ and delegated this donation authority to MNF-I. According to DOD officials, in June 2008, the Deputy Under Secretary of Defense for Logistics and Materiel readiness increased the authority to transfer (formerly known as donation authority) for all U.S.-owned excess personal property in Iraq from \$10,000 to \$15,000. In addition, in 2007 the Army published guidelines for the retrograde of contractor-acquired government-owned property from CENTCOM's area of responsibility.⁴⁰ The Army followed this up in December 2007 with a business case analysis of the effective disposition of contractor-acquired government-owned property and a conference in May 2008 during which it updated and developed policies and processes for maintaining accountability over this

³⁸Excess contractor-managed government-owned property is a subset of foreign excess personal property, which is defined as U.S.-owned personal property located outside of the United States that is excess to government needs.

³⁹The October 2007 memo increasing donation authority to \$10,000 updated an August 4, 2006, DOD memo based on the Defense Reutilization and Marketing Service's cost-benefit analysis dated June 9, 2006, which estimated the cost at which care and handling of an item exceeds the proceeds from its sale.

⁴⁰Headquarter, Department of the Army, HQDA *Materiel Retrograde Policy*; (October 23, 2007).

property.⁴¹ The Army's analysis indicates that approximately 85 percent of all contractor-acquired government-owned property in Iraq should be transferred,⁴² sold, or scrapped in Iraq once it is declared excess,⁴³ while the remaining 15 percent can be sold or reused elsewhere. Finally, in its Logistics Reposture Guidance, MNF-I established policies and procedures for disposing of contractor-managed government-owned property in Iraq. This process is shown in figure 2 below.

Figure 2: MNF-I Process for Disposing of Contractor-Managed Government-Owned Property

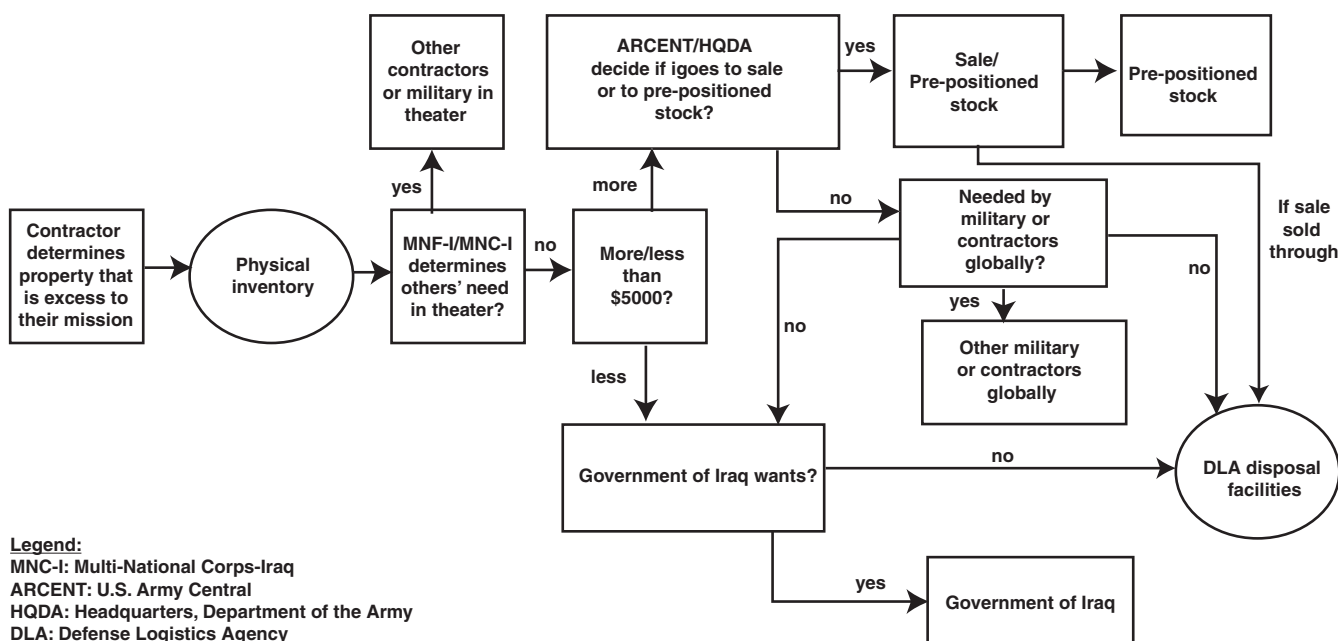

Source: GAO analysis of DOD information

Despite the above efforts, however, three challenges exist to maintaining accountability for and managing the disposition of contractor-managed

⁴¹ According to an Army official, this analysis included property acquired/fabricated by the contractor, but not government-furnished equipment. Consequently, the analysis included much, but not all contractor-managed government-owned property.

⁴² The property can be transferred to other military units or contractors in theater, the government of Iraq, or other military units or contractors around the world.

⁴³ The Army's analysis considers this property to be (1) uneconomical to return to the United States or (2) prohibited from return to the United States given policy, regulations, or agreements.

government-owned property in Iraq. The first challenge is determining the original or fair-market value of contractor-managed government-owned property and determining any security restrictions on its disposition. According to MNF-I, the failure to sort and identify U.S. government materiel in Iraq has already resulted in the retrograding of items that are unserviceable, are still needed in theater, or are uneconomical to retrograde. Moreover, according to the Department of the Army's business case analysis, the LOGCAP property book kept by the prime contractor had numerous omissions, and many items were not properly listed, creating doubt about the inventory's accuracy. Without accurate accountability of contractor-managed government-owned property in Iraq, the U.S. government may fail to realize all possible financial and practical gains from this property.

The second challenge facing DOD, according to Defense Contract Management Agency officials, is the time-consuming and labor-intensive task of accounting for and determining the disposition of contractor-managed government-owned property. According to MNF-I, before contractor-managed government-owned property can be disposed of it must be transferred from the contractor's records to a military unit's property book. However, officials from the Defense Contracting Management Agency stated that contractors and government officials must perform a joint inventory of all property before it is transferred. Defense Contract Management Agency officials assert that completing this inventory will require planning, travel to storage locations, and the physical staging of property for easier counting, all of which are time consuming. Moreover, the same officials stated that security concerns have previously hindered their ability to travel to all inventory locations. According to AMC, if the security situation inhibits contractors from moving equipment, the contractors can abandon the equipment to U.S. forces that will then be responsible for its disposition. Defense Contract Management Agency officials stated that without adequate time and resources to plan and execute a thorough inventory of contractor-managed government-owned property in Iraq, the risks of losing accountability over this property will increase.

The third challenge is that DLA may not have sufficient data to adequately plan capacity needs at the Defense Reutilization and Marketing Offices in

theater.⁴⁴ MNF-I policy states that contractor-managed government-owned property that is excess to government requirements, and is not donated to the Iraqi government, will be disposed of at DLA facilities. To prepare for this, DLA officials attached to MNF-I told us they spent 3 months performing a detailed analysis of how much equipment will end up at these facilities in theater. Despite these efforts, however, there are six factors that may affect DLA's ability to accumulate sufficient data to adequately plan capacity needs at DLA's disposal facilities.

- LOGCAP inventory accuracy. A Department of the Army business case analysis stated that problems with the LOGCAP property book created doubt about the inventory's accuracy. While according to an Army official the LOGCAP prime contractor is currently performing an inventory of all of its property in Iraq, the process is adding new items to their property books, making older property estimates outdated.
- Lack of property disposal estimates. According to DOD officials, MNF-I requested but never received the services' estimates of what they anticipate sending to the disposal facilities.
- Lack of property book data. According to DOD officials, MNF-I did not receive property books from the Army Corps of Engineers and only received partial information from the Air Force Contract Augmentation Program.
- Lack of visibility over non-DOD property. According to Defense Contract Management Agency officials, it is difficult to determine how much equipment is managed by contractors under the hundreds of smaller programs run by individual U.S. government agencies.
- Lack of individual item accountability. According to DOD officials, many of the systems used to account for contractor-managed government-owned property only track types of items, but not necessarily the individual items themselves, making detailed estimates difficult.
- Insufficient training. According to DOD officials, some retrograde process teams sent to aid redeploying units have not had sufficient training, causing them to send unnecessary property to disposal facilities.

DLA has implemented other initiatives to mitigate and prepare for increased operations at the disposal facilities. For example, DLA fielded

⁴⁴DLA runs four Defense Reutilization and Marketing Offices in Iraq and one in Kuwait, which are responsible for disposing of surplus DOD property through reutilization, transfer, donation, and sale. The sale of this surplus property is accomplished by awarding contracts to vendors that in turn resell the property.

individuals to accompany a key retrograde assistance team to prevent unnecessary equipment from ending up at these facilities and, according to DLA officials, in one instance they successfully rerouted 194 of 200 containers, reducing the chance of double-handling this property. However, without a comprehensive picture of all property in theater, DLA may not be able to fully prepare its disposal facilities for the contractor-managed government-owned property that will flow to them, particularly in the event of a full-scale reposturing.

Use of Facilities in Kuwait and Other Neighboring Countries

The pace at which units can be redeployed and equipment and materiel retrograded as part of any reposturing of U.S. forces from Iraq would be governed by the capacity of facilities in neighboring countries as well as restrictions on the use of those facilities. According to DOD officials, Kuwait is the main point of exit for all personnel, equipment, and materiel in Iraq. At present there are three U.S. bases and five Kuwait facilities that the United States is using to support operations in Iraq, including retrograde and redeployment operations. The U.S.-Kuwait Defense Cooperation Agreement governs the use of these facilities. According to DOD officials, any reposturing effort must take into consideration the terms of the Defense Cooperation Agreement and ongoing negotiations related to that agreement, particularly given that in their view, the government of Kuwait desires to limit the size of the U.S. footprint in Kuwait. DOD has explored alternative routes and ports through which to redeploy units and retrograde equipment and material but these, too, are constrained because of capacity and other considerations. For example, in February 2008 the Marine Corps began testing the feasibility of using an alternate port in the region for redeployment and retrograde operations.⁴⁵ However, Marine Corps officials stated that though the tests have been successful, at present the country in which that port is located only allows the transport of containerized cargo through its territory and will not permit U.S. military security detachments to escort the cargo. As a result of these restrictions, Marine Corps officials reported they could retrograde only 20 to 30 percent of their nonsensitive materiel and equipment in Iraq through this port. ARCENT officials are also studying the feasibility of using two other alternate ports in the region. However, according to ARCENT documents, one port has limited utility as a retrograde port because the shallow draft of the harbor makes it unsuitable for larger

⁴⁵ The Marines have previously used this alternate port to resupply its forces in western Iraq.

ships, the port's facilities are in need of significant renovation, and local security at the port is questionable. The third port is limited to containerized cargo as well as being limited by the amount of cargo traffic that can travel along the port's approach roads.

Availability of Wash Racks and Customs Personnel

Limits on the availability of wash racks in Kuwait and a limited number of customs inspectors comprise another constraint on the pace at which retrograde operations can be effected. Prior to returning to the United States all materiel and equipment must be cleaned to U.S. Department of Agriculture (USDA) standards. These standards are outlined in The Armed Forces Pest Management Board Technical Guide No. 31, which states that "USDA inspection standards only allow a thin film of road dust on vehicles and equipment arriving at the CONUS [continental United States] final port of entry," which DOD officials interpret to mean that materiel and equipment cannot have even a "pinchable" amount of dirt. To meet these standards of cleanliness, DOD officials stated that all vehicles returning to the United States are pressure washed. This involves, first, removing the vehicle's secondary equipment and any add-on armor. Next, the vehicle moves to a wash rack where the pressure washing occurs. For larger vehicles, such as tanks, Bradley Fighting Vehicles, and M88 recovery vehicles this can take anywhere from 40 to 80 hours (larger vehicles must also have their engines removed and the engine compartment cleaned as well). Smaller vehicles, such as HMMWVs, take anywhere from 4 to 8 hours.

At present there are 211 wash racks available for use by U.S. forces in Kuwait, 81 at Camp Arifjan and another 130 at Kuwait Naval Base.⁴⁶ According to DOD officials, the wash racks at Camp Arifjan operate 24 hours a day. However, wash rack operations at Kuwait Naval Base are subject to occasional work stoppages and other restrictions. For example, when ammunition is being loaded or unloaded at the naval base, wash rack operations there are suspended for safety reasons. According to DOD officials, at present this only occurs for 6 days each quarter, but if the retrograde of ammunition were accelerated this could occur more often. Moreover, theater provided equipment, which is washed by contracted third-country nationals, cannot be washed at Kuwait Naval Base because of security concerns. And of the 130 wash racks at the naval base, only 100

⁴⁶ DOD officials stated that an additional 20 wash racks should be operational at Camp Buehring by August 2008; we were not able to confirm this.

are useable for the cleaning of equipment because the remaining 30 lack the necessary filters that separate contaminants from the wash water.

Figure 3: Bradley Fighting Vehicles at Wash Racks



Source: DOD.

Figure 4: HMMWV on Wash Rack



Source: DOD.

After being washed, vehicles are inspected by military personnel who have been specially trained and certified by the U.S. Customs and Border Protection Agency. These customs inspectors ensure that before any vehicle or piece of equipment is placed in a sterile lot, the last stop before it boards transport for return to the United States, it meets USDA standards of cleanliness. In Kuwait, these trained inspectors are provided by the U.S. Navy. Navy officials have stated that at present there is no shortage of trained and certified customs inspectors in Kuwait given the current throughput of retrograding material and equipment. However, other DOD officials have noted that were the pace of retrograde increased, more customs inspectors would be necessary. They also stated that absent an increase in the number of inspectors, otherwise clean vehicles would be delayed from entering the sterile lot and would therefore require additional cleaning to meet customs standards of cleanliness. In turn, this could cause a backlog of vehicles and materiel in Kuwait.

Availability of Transportation and Security Assets and Route Restrictions

The availability in theater of military owned and operated heavy equipment transports and convoy security assets, combined with limits on the primary supply route, could inhibit the flow of materiel out of Iraq. According to DOD officials, two types of heavy equipment transports (HET) support U.S. forces in the Iraqi theater of operations: commercially contracted unarmored transports and armored military transports with military crews. Both types of transport are used to haul vehicles like tanks, Bradley Fighting Vehicles, and HMMWVs over long distances.⁴⁷ They also carry containers.

According to DOD officials, there are sufficient quantities of civilian HETs in the Iraqi theater of operations. However, one factor affecting the frequency with which convoys can be mounted is the availability of military HETs and convoy security assets. According to officials from the 1st Theater Sustainment Command, most convoys comprise both civilian and military HETs, with the latter being interspersed throughout the convoy to facilitate control and security. Any increase in the number of civilian HETs without a corresponding increase in the number of military HETs, they maintain, increases the risk of accidents. However, DOD officials have reported shortages of military HETs in theater. In addition, officials from the 1st Theater Sustainment Command stated that each convoy is accompanied by a mounted security detachment. According to ARCENT officials, the availability of these convoy security assets could also inhibit the flow of materiel out of Iraq by decreasing the frequency with which convoys can be mounted.

One other factor that could inhibit the rate by which units can be redeployed and material and equipment retrograded out of Iraq into Kuwait is the capacity of the primary supply route. Prior to May 2007, U.S. convoys used a six-lane concrete highway. However, according to III Corps officials, the government of Kuwait funded the construction of an alternate route that opened in May 2007. These officials explained that the new route is not wide enough to handle two-way HET traffic and is deteriorating. III Corps officials stated that, because of this, the flow of convoys north and south along the newer route must be staggered, which further limits the number and frequency of retrograde convoys. Moreover, according to DOD officials under all but the most extreme reposturing

⁴⁷ According to DOD officials, although it is possible to self-deploy vehicles from Iraq to Kuwait (i.e., drive them out under their own power), the resulting wear and tear on a vehicle makes this an unattractive alternative. Hence, when possible, vehicles are transported out of Iraq on heavy equipment transports.

scenarios, substantial numbers of convoys will need to continue flowing north to resupply Coalition forces in Iraq.

Home Station Issues

During our visits to units and installations in the United States as well as conversations with DOD officials, we became aware of several issues that could challenge units once they have returned to their home stations. Although these issues need to be explored further, they are included in this report because of their potential impact. These issues are:

- A lack of sufficient numbers of mental health professionals to care for returning service members and their families. According to Army officials and GAO analysis there is already a deficiency in the number of mental health providers given the rise in the number of mental health problems being reported by service members and their families. The Army has already taken steps to meet this challenge through hiring and contracting for additional mental health care professionals to meet the rising demand, but they report that there remains a dearth of qualified mental health professionals to provide the requisite care for service members and their families.
- A lack of sufficient infrastructure. According to Army officials there is already insufficient infrastructure such as barracks, administrative and headquarters buildings, motor pools, and maintenance and training areas on several installations. This is due to the “Grow the Army” initiative which has increased the number of brigade combat teams in the Army since the beginning of the war in Iraq. As a result, some installations have more Army units assigned to them than there are facilities to support. Currently, the Army is able to mitigate this challenge because a certain number of units are always deployed. This allows the Army to use the same facilities for more than one unit. However, installation management officials are concerned that in the event of a major reposturing of units out of Iraq and the concomitant return of Army units to their home stations there will not be enough room to accommodate all of the equipment, unit headquarters staff, and soldiers stationed at an installation.
- Needed future investments in training and equipment. According to recent testimony by the Secretary and Chief of Staff of the Army, resetting the force so that it is capable of “full spectrum operations” will require substantial future investments in time, money, and resources. This point was underscored for us during discussions with officials from the 1st Cavalry Division that had recently returned from Iraq. They told us that it would not be until 6 to 9 months after

returning from Iraq that their brigade combat teams would have the necessary equipment with which to train.

Lastly, though DOD is not required to report on the specific issues we identify in this report or possible mitigation plans related to these issues as part of the briefings they are required to provide to the congressional defense committees, we believe that without such specific information Congress may not be able to effectively exercise its oversight responsibilities and stewardship over DOD.

Conclusions

Although DOD began in May 2008 to coordinate its planning for the reposturing of U.S. forces from Iraq among its various relevant commands and organizations, it has not adequately delineated roles and responsibilities for the execution of the associated retrograde process. Specifically, although CENTCOM has designated an executive agent for the synchronization of retrograde operations in the theater, no unified or coordinated chain of command exists to account for the roles played by a variety of teams engaged in retrograde operations. In addition, while the Army has designated ARCENT as its lead element for retrograde of Army material and equipment from the CENTCOM AOR, until recently ARCENT had no command authority over the two Army units responsible for the retrograde of the bulk of material and equipment in Iraq. Instead, there are a variety of organizations, some in theater and others in the United States, that exercise influence over the retrograde process, either directly or through subordinate organizations in the Iraqi theater of operations. The resulting lack of a unified or coordinated command structure is not only inconsistent with joint doctrine, but also increases confusion and causes inefficiencies in the retrograde process and inhibits the adoption of identified mitigation initiatives.

In addition, we identified several other issues that DOD will need to consider as it develops a comprehensive plan for reposturing U.S. forces from Iraq to support future U.S objectives and strategy. While DOD has begun to address these issues, none of them have been fully addressed. Moreover, because Congress will have a role in funding and overseeing the reposturing effort, it is important that the Congress be informed of these issues since they will likely affect DOD's overall reposturing costs and execution. While DOD is required to brief the congressional defense committees on certain issues related to reposturing, it is not required to provide the specific information identified in our report. We believe that without such information, Congress may not be able to effectively exercise

its oversight responsibilities and assess the extent to which DOD's plans are effective, efficient, and well-coordinated.

Recommendations

To ensure that DOD can efficiently and effectively retrograde its materiel and equipment from Iraq, we recommend that the Secretary of Defense, in consultation with CENTCOM and the military departments, take steps to clarify the chain of command over logistical operations in support of the retrograde effort. These steps should address not only the Army field support brigades but also the theater property and retrograde support teams. We also recommend that the Secretary of Defense, in consultation with the military departments, correct the incompatibility weaknesses in the various data systems used to maintain visibility over equipment and materiel while they are in transit.

Matter for Congressional Consideration

To enhance its ability to exercise its oversight responsibilities, Congress may wish to consider directing DOD to include in its briefings submitted in accordance with the National Defense Authorization Act for Fiscal Year 2008, specific details on the status of its reposturing planning and how it intends to mitigate specific reposturing issues, including those we identified in this report, as well as other challenges the department envisions as it proceeds with its reposturing efforts.

Agency Comments and Our Evaluation

In written comments on a draft of this report, DOD generally concurred with our two recommendations. Specifically, the department partially concurred with our first recommendation and fully concurred with our second recommendation. DOD also commented that from the time we began this review to the completion of our data collection, the operational environment in theater has changed, processes have been modified, and actions have been taken to mitigate the concerns identified in our draft report. We recognize in our report that the operational environment has changed over time and that DOD has recently modified some processes and taken actions to enhance its planning for the reposturing of forces from Iraq. However, as discussed below, we continue to believe that DOD needs to take additional actions to implement our recommendations and improve the efficiency of its retrograde process.

In response to our first recommendation that the Secretary of Defense, in consultation with CENTCOM and the military departments, take steps to clarify the chain of command over logistical operations in support of the retrograde effort, DOD stated that the current retrograde command and

control achieves unity of effort and is producing positive results. DOD further commented that CENTCOM has designated the U.S. Army Central Command (ARCENT) as the executive agent for the retrograde process, and that ARCENT also has operational control of the two Army Field Sustainment Brigades we discuss in the report. DOD believes that the established liaison and supporting/supported relationships by retrograde support teams are achieving unity of effort in retrograding theater property through the regular Logistics Reposture Working Groups where collaboration and coordination occur. DOD further commented that, for a longer term solution, CENTCOM is taking steps to refine and solidify a theater logistics command and control structure from its current construct to a Joint Task Force Theater Logistics Command under the CENTCOM Commander. DOD stated that its plan for this new command is phased, conditions-based, and its execution will be coordinated within the overall theater posture process with appropriate DOD agencies and the military services. We support DOD's and CENTCOM's long-term plan to refine and solidify its command and control structure for managing and executing the retrograde process. In addition, we are aware that subsequent to completing our audit work in Kuwait and drafting our report, CENTCOM refined the logistical command and control structure by placing the 401st and 402nd Army Field Support Brigades under the operational control of the commanding general, Army Materiel Command, Southwest Asia. Although we have not had the opportunity to evaluate the effect of this new command arrangement, we believe it to be a significant step toward the attainment of unity of command over the theater provided equipment retrograde process. However, CENTCOM has not implemented a similar action with regard to the command and control of the ten theater property and retrograde support teams that facilitate the redeployment and retrograde processes. According to ARCENT, this lack of unity of command over these teams makes their roles and responsibilities as they relate to the retrograde of equipment and materiel unclear and confusing. As a result, we continue to believe that DOD, in consultation with CENTCOM and the military departments, needs to immediately address the current confusion and lack of clarity regarding the command and control of the various commands and support teams that support the retrograde operations in Iraq and Kuwait.

DOD fully concurred with our second recommendation that the Secretary of Defense, in consultation with the military departments, correct the incompatibility weaknesses in the various data systems used to maintain visibility over equipment and materiel while they are in transit. DOD commented that it is actively assessing various data systems used to maintain visibility over equipment and materiel while in transit.

DOD also provided a number of general and technical comments which we have incorporated in the report as appropriate. A complete copy of DOD's written comments, including the department's general and technical comments and our evaluation of each of those comments, is included in appendix II.

We are sending copies of this report to the appropriate congressional committees; Secretary of Defense; the Secretaries of the Army, Navy, and Air Force; and the Commandant of the Marine Corps. We will also make copies available to others on request. In addition, the report will be available at no charge on the GAO Web site at <http://www.gao.gov>.

Should you or your staff have any questions on the matters discussed in this report, please contact me at (202) 512-8365 or solisw@gao.gov. Contact points for our Offices of Congressional Relations and Public Affairs may be found on the last page of this letter. GAO staff who made key contributions to this report are listed in Appendix VII.

A handwritten signature in black ink, appearing to read 'W. Solis', with a long horizontal flourish extending to the right.

William M. Solis
Director, Defense Capabilities and Management

List of Congressional Committees

The Honorable Carl Levin
Chairman
The Honorable John McCain
Ranking Member
Committee on Armed Services
United States Senate

The Honorable Daniel K. Inouye
Chairman
The Honorable Thad Cochran
Ranking Member
Committee on Appropriations
Subcommittee on Defense
United States Senate

The Honorable Ike Skelton
Chairman
The Honorable Duncan L. Hunter
Ranking Member
Committee on Armed Services
House of Representatives

The Honorable John P. Murtha
Chairman
The Honorable C.W. Bill Young
Ranking Member
Committee on Appropriations
Subcommittee on Defense
House of Representatives

Appendix I: Scope and Methodology

To determine the extent to which the Department of Defense (DOD) has begun logistical planning for the reposturing of forces from Iraq and upon what assumptions it based its plans, we reviewed relevant briefings, orders, and staff analyses relating to the logistical planning effort and discussed the effort with DOD officials who were directly involved. We met with many of these individuals several times over the course of this engagement either in person, telephonically, or by video teleconference. As a result, we were able to obtain updated information that allowed us to discuss the means by which the logistical planning effort evolved over time. We also obtained copies of the briefings presented during the May 2008 logistical summit held at Camp Arifjan, Kuwait, as well as a copy of the logistical reposturing order that resulted from that summit, and met with many of the senior DOD officials who participated in that summit. The documents we obtained and officials we spoke with were from U.S. Transportation Command; U.S. Joint Forces Command, U.S. Central Command; Multinational Force-Iraq; the Defense Logistics Agency; Army Materiel Command; Headquarters, Department of the Army; Headquarters, U.S. Marine Corps; U.S. Army Central at both Fort McPherson, Georgia, and Camp Arifjan, Kuwait; Headquarters, U.S. Marine Corps, Central; U.S. Army Forces Command; Headquarters, II Marine Expeditionary Force; Headquarters, III Corps; and the 1st Theater Support Command.

To determine the extent to which DOD has established roles and responsibilities for managing and executing the retrograde of materiel and equipment from Iraq, we reviewed and analyzed documents from and interviewed officials in the organizations that were either directly responsible for the retrograde process or that negotiated the process. We also reviewed relevant DOD regulations and joint and Army doctrine publications. To determine how the retrograde process was actually executed we obtained documents and interviewed officials from Multinational Force-Iraq; the Defense Logistics Agency; Army Materiel Command, to include the commanding general, Army Material Command, Southwest Asia; Headquarters, Department of the Army; Headquarters, U.S. Marine Corps; U.S. Army Central at both Fort McPherson, Georgia, and Camp Arifjan, Kuwait; Headquarters, U.S. Marine Corps, Central; Headquarters, II Marine Expeditionary Force; the 1st Theater Support Command; and the 401st and 402nd Army Field Support Brigades. To gain insight on the experience of units that had passed through the retrograde process we obtained documents and interviewed officials from III Corps and the 1st Cavalry Division, both at Fort Hood, Texas, and the II Marine Expeditionary Force at Camp Lejeune, North Carolina.

During the course of this engagement we became aware of several challenges that could have an impact on the reposturing of U.S. forces from Iraq and have included a discussion of these challenges in this report in order to provide Congress with information it needs to effectively carry out its oversight functions. We based our discussion of those issues on documents we obtained and interviews with officials from Headquarters, Department of the Army; Headquarters, Marine Corps; U.S. Central Command; U.S. Transportation Command; U.S. Joint Forces Command; the Defense Logistics Agency; Army Materiel Command; III Corps and Fort Hood, Texas; Headquarters, U.S. Marine Corps, Central; Headquarters, II Marine Expeditionary Force; U.S. Army Central at both Fort McPherson, Georgia, and Camp Arifjan, Kuwait; and 1st Theater Support Command.

We have also provided in this report several challenges facing units once they have returned to their home stations. As with the challenges above, we became aware of these issues during the course of our engagement. Although these issues need to be explored further, they are included in this report because of the impact they could have on the morale and welfare of service members and their families and the potential costs and challenges associated with rebuilding unit readiness. We became aware of these issues following discussions with officials from U.S. Army Forces Command; Assistant Chief of Staff for Installation Management; U.S. Army Medical Command; U.S. Army Installation Management Command; the U.S. Army Surgeon General's Office; III Corps and Fort Hood, Texas; the 1st Cavalry Division; and Headquarters, II Marine Expeditionary Force.

From the fall of 2007 through the spring of 2008, we also made several attempts to visit Iraq to speak with officials from Multinational Force-Iraq, Multinational Corps-Iraq, and various organizations involved with the logistical aspects of reposturing. But for reasons that are not entirely clear, DOD stated that it was unable to accommodate these visits. However, we were able to mitigate our inability to visit Iraq by:

- interviewing officials with knowledge of the logistical aspects of reposturing who had recently returned from tours on the MNF-I or MNC-I staffs;
- visiting Headquarters, III Corps at Fort Hood, Texas, after it returned from its block leave following its return from Iraq, where III Corps served as Headquarters, Multinational Corps-Iraq;
- interviewing officials from organizations stationed in Iraq who were in Kuwait during our visit to Camp Arifjan, Kuwait; and
- submitting lists of questions through U.S. Central Command for organizations in Iraq.

Although we were not always able to obtain full answers to our list of questions, based on our analysis of the information we were able to obtain we determined that we had sufficient information to substantiate our findings.

We conducted our audit from August 2007 through August 2008 in accordance with generally accepted government auditing standards. Those standards require that we plan and perform the audit to obtain sufficient, appropriate evidence to provide a reasonable basis for our findings and conclusions based on our audit objectives. We believe that the evidence obtained provides a reasonable basis for our findings and conclusions based on our audit objectives.

Appendix II: Comments from the Department of Defense

Note: GAO comments supplementing those in the report text appear at the end of this appendix.



INTERNATIONAL
SECURITY
AFFAIRS

OFFICE OF THE ASSISTANT SECRETARY OF DEFENSE
2400 DEFENSE PENTAGON
WASHINGTON, DC 20301-2400

SEP 03 2008

Mr. William A. Solis
Director, Defense Capabilities and Management
U.S. Government Accountability Office
441 G Street N.W.
Washington, DC 20548

Dear Mr. Solis:

This is the Department of Defense (DoD) response to the Government Accountability Office (GAO) draft report, GAO-08-930, "OPERATION IRAQI FREEDOM: Actions Needed to Enhance DoD Planning for Reposturing of U.S. Forces from Iraq," dated August 8, 2008 (GAO Code 351092).

Thank you for the opportunity to review the draft report and your effort to enhance the retrograde process from Iraq. From the period that GAO began its research until its data collection concluded, the operational environment in theater has changed, processes have been modified and set, and actions have been taken to mitigate the concerns identified in the draft report. Below are the Department's comments on the draft report's recommendations.

Recommendation 1: To ensure that DoD can efficiently and effectively retrograde its materiel and equipment from Iraq, GAO recommends that the Secretary of Defense, in consultation with U.S. Central Command (USCENTCOM) and the military departments, take steps to clarify the chain of command over logistical operations in support of the retrograde effort. These steps should address both the theater property and retrograde support teams and the Army field support brigades.

DoD Response: Partially concur. The current retrograde command and control achieves unity of effort and is producing positive results. USCENTCOM has designated U.S. Army Central (ARCENT) as the executive agent for retrograde process. ARCENT also has operational control (OPCON) of the two Army Field Sustainment Brigades of concern in the draft report. Established liaison and supporting/supported relationships by retrograde support teams are achieving unity of effort in retrograding theater property through regular Logistics Reposture Working Groups where collaboration and coordination occur.

For a longer term solution, USCENTCOM is also taking steps to refine and solidify a theater logistics command and control structure from its current construct to a



Joint Task Force Theater Logistics Command under the CENTCOM Commander. The plan is phased, conditions-based, and its execution will be coordinated within the overall theater posture process with appropriate DoD agencies and the Services.

Recommendation 2: GAO also recommends that the Secretary of Defense, in consultation with the military departments, correct the incompatibility weaknesses in the various data systems used to maintain visibility over equipment and materiel while they are in transit.

DoD Response: Concur. DoD acknowledges the focus of this draft report has been on Army systems. DoD is actively assessing various data systems used to maintain visibility over equipment and materiel while in transit.

Attached are additional detailed comments and corrections.

Sincerely,

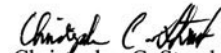

Christopher C. Straub
Deputy Assistant Secretary of Defense
for the Middle East

Attachments:
As stated.

**DRAFT GAO REPORT “OPERATION IRAQI
FREEDOM: ACTIONS NEEDED TO ENHANCE DOD
PLANNING FOR REPOSTURING OF U.S. FORCES
FROM IRAQ,” DATED AUGUST 8, 2008**

GAO CODE 351092/GAO-08-930

GENERAL COMMENTS ON THE DRAFT REPORT

See comment 1.

- Current retrograde efforts. As of August 2008, during fiscal year 2008, U.S. Army Central (ARCENT) has retrograded over 7,000 major end items back to CONUS. U.S. Marine Central is also successfully retrograding end items for reset. Defense Logistic Agency (DLA), through Defense Reutilization and Market Services in theater, has disposed of 175 million pounds of scrap metal. Through its transportation priority program, U.S. Transportation Command (USTRANSCOM) has saved the Army over 40% in shipping costs by using empty cargo aircraft backhaul capability.

See comment 2.

- Chain of command for logistics operations in support of retrograde. Directive Authority for Logistics (DAFL) has not been assigned from USCENTCOM. USCENTCOM has designated ARCENT as the executive agent for logistics repositioning/retrograde. In the Iraqi theater, MultiNational Forces-Iraq (MNF-I) has established processes and procedures for addressing theater logistics issues. These lines of operations include basing, unit redeployment, and materiel disposition. Unity of effort is accomplished by working groups that have been established to collaborate and coordinate with joint stakeholders and partners. (Services, USCENTCOM, DLA, USTRANSCOM). For example, both MNF-I and MultiNational Corps-Iraq (MNC-I) have established Logistics Reposture Working Groups. They are enduring forums that meet regularly with all the key logistics organizations in Iraq and Kuwait to address respective strategic, operational, and theater level logistics issues. Two of the key documents are the MNF-I FRAGO 08-232 and draft MNC-I FRAGO that establish redeployment timelines.

See comment 3.

- Retrograde Support Teams are specifically addressed within these unit redeployment timelines. Each of the assistance teams have specific missions based on guidance and direction from parent commands and from operational commands in theater. Each assistance team is synchronized within the redeployment timeline and brings its own set of expertise to facilitate in retrograde and reposture efforts.

See comment 4.

- Theater Property and Army Field Support Brigades (AFSB) - The majority of equipment is organizational and will retrograde as a unit responsibility. Army Materiel Command's (AMC) forward Field Support Brigades are responsible for

1

See comment 5.

retrograde of excess theater provided equipment and assuming control of organizational equipment directed for sustainment-level reset.

- In transit visibility of materiel - For Army systems, AMC, with its subordinate commands and the various headquarters in theater, is actively working to establish a Reposturing Common Operating Picture (RCOP) to mitigate the cited incompatibility weaknesses in the various data systems used to maintain visibility over equipment and materiel while in transit. While significant challenges in this process remain, AMC has already identified system interfaces to be used. Moreover, a RCOP Working Group will meet regularly to establish the necessary systems interfaces and address procedures used for accountability, transportation scheduling and documentation, and equipment in-transit visibility. In addition to these efforts, USCENTCOM J4 has joined with JFCOM J9 to identify distribution/in-transit visibility requirements, processes and capability gaps to the Joint Staff J4 to support the development of in-transit visibility capabilities for Joint Logistics Organizations within Global Combat Support System – Joint (GCSS-J).

See comment 6.

1. Highlight Page, second paragraph. We recommend rewording of the first four lines of this paragraph to more accurately portray what has occurred since May 2008. As noted from page 15, the draft clearly states representatives from throughout the logistics community and theater met as a result of the increased coordination and synchronized planning, and the outcome was the MNF-I publication of its overarching guidance for the logistics reposturing.

See comment 7.

2. Pages 1, 7, 10, 11, 13, 19, 25, 26, 33. There are several references to “bases” throughout the report, especially linked to the number 311. This does not accurately characterize the force laydown in Iraq. The word “bases” should be replaced by “locations” in most cases to reflect the true nature of the places used by U.S. forces.

See comment 8.

3. Page 1. The draft report states, “as of July 2008, this pool of theater provided equipment totaled approximately 582,000 individual pieces worth about \$15.5 billion.” Army G8 reports that, for Class VII items in Iraq only, a property book pull from the end of March 2008, used in a J8/OSD Study, found 173,000 items (Class VII only) worth approximately \$16.5 billion.

See comment 9.

4. Page 2. Recommend deletion of the sentence: “In addition, in June 2008, GAO also issued an assessment of progress in Iraq and called for DOD and the DOS to develop an updated strategy given the changing conditions.” This sentence is not relevant to the GAO’s objectives for this engagement, and the referenced GAO report’s conclusions were rebutted by DoD.

See comment 10.

5. Pages 1-3. Discussions regarding the National Defense Authorization Act for 2008 appear as a distraction from the draft report and its overall conclusions.

See comment 11.

6. Page 5. First paragraph, please add: "Army Headquarters G-4 began hosting retrograde video teleconferences (VTCs) in June 2006 and moved to monthly VTCs in August 2007. The purpose of the VTCs was to synchronize retrograde planning efforts. DLA and AMC participated in the VTCs. Starting in October 2007, Army Headquarters G-4 expanded the Retrograde Task Force to include OSD, Joint Staff, Air Force, Marine Corps, USCENTCOM, MNF-I, MNC-I, and USTRANSCOM, NG, and OCAR.

See comment 12.

7. Page 7. Concerning capacity of military transports and convoy security assets and limits on the main supply route, we partially concur. We concur with the draft GAO report that sufficient commercial heavy equipment transports (HET) assets exists in theater to augment military HET assets for redeployment operations. Additionally, other transports such as flatbeds and lowboys, can move all but the heaviest equipment, reducing the need for HET transports. However, we partially concur with the statement regarding limits on convoy security assets. While convoy security requirements stretch resources, approved commercial security firms can be contracted to provide additional security teams that can be used for sustainment missions, freeing up military escort teams to support redeployment. Additionally the military has an active program that eliminates the requirement to provide security for low priority materials, thereby freeing up more military escort teams. If necessary, military units can provide security for their own assets as they redeploy. We concur with the GAO statement regarding insufficiency of mass redeployments through Kuwait, and DoD is actively engaged in increasing the availability and capacity of redeployment of assets through alternative ports in Jordan and Turkey, as well as Iraq's own major port, Umm Qasr. Efforts are also underway to make greater use of the Iraq railroad and Iraqi Transportation Network, which will have the potential to move significant amounts of cargo to points near redeployment ports.

See comment 13.

8. Page 7, 37-38. Concerning the increased demand for access to mental healthcare providers, the draft GAO report states, "According to Army officials and GAO analysis, there is already a shortfall in the number of mental health providers given the rise in the number of mental health problems being reported by service members and their families." We concur and note: MNF-I CJ1/4/8 Surgeon is following established procedures to ensure all service members take Post Deployment Health Assessments 30 days prior to redeploying. Service members are required to take another Post Deployment Health Assessment 90-120 days after returning to CONUS and home station. These surveys are essential to monitor mental health throughout DoD. In addition, teams of mental health professionals conduct surveys in theater to keep commanders apprised on issues of mental health.

See comment 14.

9. Page 12. The report states that “Despite working on the same broad set of issues, however, there was little coordination and communication among the three organizations. Moreover, both USCENTCOM, the combatant command whose area of responsibility includes Iraq and Kuwait, and MNF-I, the headquarters responsible for operations in Iraq, provided little input and guidance to these planning efforts.” Recommend delete above statement and change statement to read: “*The coordination was maintained at an informal liaison level.*” The Army Sustainment Command (ASC) liaison officer at USCENTCOM J4 worked with ASC and USCENTCOM J4 to prepare the command for future reposture/retrograde efforts in July and August 2007. This assisted in preparing AMC’s warning order.

See comment 15.

10. Page 15. Recommend adding the following: “The MNF-I Logistics Reposture Working Group is an enduring forum with all the key logistics organizations in the Iraq and Kuwait theater. It meets monthly and addresses strategic, operational, and theater level logistics issues. It assigns Offices of Primary Responsibility (OPRs) or Operational Planning Teams to develop solutions to logistics related issues.”

See comment 16.

11. Page 15. The MNF-I FRAGO on Logistics Reposture Guidance not only addresses Materiel Disposition and Unit Redeployment, but also addresses basing. Recommend adding the following: “Basing options include a base’s closure, a transfer to the Government of Iraq, or a ‘shrink and share’ of a base where both Iraqis and Coalition forces collocate in a landlord-tenant relationship.”

See comment 17.

12. Page 17. Regarding unity of command, although the command and control is not a text book joint doctrinal command and control system, it is the theater process by which units have redeployed successfully since the beginning of OIF. It requires constant management, interface, and decision making across all levels of logistics. Deliberate/advance planning, communication via liaison officers, and collaboration are all essential to making the process function.

See comment 18.

13. Pages 6-7. We recommend deleting the footnote attached to the standards for environmental management and guidance for the disposition of property. Additionally, MNF-I has procedures in place regarding environmental management and base closure/return.

See comment 19.

14. Page 6-7. In addition, MNF-I, working with MNC-I, has a base closure/return plan in place that has been used successfully in the past and is currently being refined as we engage more with the GoI on closures/returns and property transfers (real property and personal property). A Combined Basing Board is now in the planning phases and will involve the Iraqi Government for decisions on base closures/return/property transfers once a site has been nominated by Coalition forces to close/return. MNF-I, in conjunction with MNC-I, is working to limit the current environmental management

requirement. Although time and cost of environmental management will be difficult to assess, progress is being made to reduce this. Examples include:

- There are 17 operational incinerators in Iraq, with 23 under construction or funded, which will reduce cost/time of burn pit management.
- MNF-I anticipated a \$54 million contract award date of September 1, 2008 for five Hazardous Waste Disposal Centers, which will also reduce cost/time of environmental management.

See comment 20.

15. Summary, 3rd paragraph. Delete “agreed upon standards for environmental cleanup and”

See comment 21.

16. Page 7. 1st bullet. Delete “standards for environmental cleanup and.”

See comment 22.

17. Page 7. Delete footnote 7.

See comment 23.

18. Page 26, 1st full paragraph, 1st sentence. Delete “environmental clean up and.”

See comment 24.

19. Page 26, 1st full paragraph, 2nd sentence. Delete “both issues are” and insert “this issue is.”

See comment 25.

20. Page 26, 1st full paragraph. Delete the fourth sentence.

See comment 26.

21. Page 27, 1st paragraph. Delete the last sentence (beginning with “Moreover”).

See comment 27.

22. Comment on Environmental Remediation (Comments 13-21 above). The draft report makes several assertions, both directly and by implication, relating to environmental remediation that are not accurate. The statements are also conclusory without supporting information. It is the longstanding policy of the Department of Defense that it does not engage in environmental remediation for the purpose of returning an installation to the host nation. Likewise, it is the longstanding policy of the Department of Defense that it does not engage in environmental remediation after return of an installation, other than in very limited circumstances where the remediation effort began prior to the decision to return and is already underway. See, e.g., DoD Instruction 4715.8, Environmental Remediation for DoD Activities Overseas, and DoD Instruction 4165.69, Realignment of DoD Sites Overseas.

It is relatively rare that a Status of Forces Agreement addresses the issue of environmental remediation and, without exception, none provide “standards” for such remediation. This is consistent with the Department’s policy that such remediation will not be conducted by the United States, other than pursuant to DoDI 4715.8. The issue of environmental remediation at installations outside the United States has been the subject of negotiations at numerous locations. To the extent that the United States “pays” for

such remediation after return, it is through the mechanism of reducing the residual value payment to reflect the cost of cleanup. Since the residual value payment reflects the current value, it is perfectly consistent with standard real estate assessment practice to consider the cost of any required environmental remediation as a deduction from total value. In fact, the requirements of DoDI 4165.69 to perform a baseline survey is designed to facilitate an informed discussion of the residual value in relation to any required environmental remediation.

The Department of Defense conducts environmental remediation at its locations outside of the United States for the purpose of protecting our personnel (and visitors) located on our installations. Such remediation is not conducted to comply with, e.g., the Comprehensive Environmental Response, Compensation, and Liability Act of 1980, which has no extraterritorial application. Such remediation is only conducted to address known imminent and substantial endangerments. What constitutes a known imminent and substantial endangerment is wholly dependent on the specific factual situation and is not amenable to the setting of general “standards” as is the case in the United States. Unless the United States has agreed to be bound by host nation law, which has not happened in the area of environmental remediation, there is no legal “standard” to be applied for purposes of environmental remediation of installations being used by United States forces.

It should also be noted that it is not uncommon for United States forces to be stationed on real property that is already contaminated by prior users. Such contamination frequently is discovered only after occupancy, particularly with regard to locations occupied during combat operations where there is rarely time or resources to conduct an environmental survey.

These comments should not be read as asserting that the Department expects to simply abandon hazardous materials when departing a site in a foreign location. It is also longstanding Departmental policy to handle hazardous materials and waste in a manner that conforms to practice in the United States, to the extent feasible given the circumstances. For instance, a site should not have solid waste (refuse) scattered around and, to the extent it does, the waste should be cleaned up prior to departure. Hazardous materials should be retrograded. Hazardous wastes should be disposed of by proper disposal or treatment when generated. These are standard practices required by existing policy and procedures.

The draft report’s assertions regarding establishing standards for environmental remediation are based on flawed assumptions and a misunderstanding of Department policy and practices worldwide.

23. Comment on Environmental Management. Change “environmental cleanup” and “cleanup” wherever they appear to “environmental management” and “management” as the case may be. The situations being addressed, e.g., reducing burn pit volume by use of incinerators, is a management function, not cleanup function. Cleanup would be removal of contamination such as a chemical plume under the surface. Proper disposition of waste in a burn pit is actually an environmental management function (“compliance”

See comment 28.

See comment 29.

See comment 30.

See comment 31.

See comment 32.

See comment 33.

See comment 34.

See comment 35.

function). To avoid possible misunderstanding, the term “cleanup” should only be used when referring to remediation, not to disposing of waste.

24. Page 11. Delete “FOB McKenzie”. It has been closed.

25. Page 18. Regarding assistance teams, each of the assistance teams have specific missions based on guidance and direction from parent commands and from operational commands here in theater. Each assistance team is synchronized within the redeployment timeline and brings its own set of expertise to facilitate in retrograde and repositioning efforts at specific dates.

26. Page 18-19. Regarding base closure, MNF-I is in the process of establishing a Combined Basing Plan and Process. An Operational Planning Team will conduct a mission analysis to close, transfer, or share Coalition forces bases, and integrate and collaborate their efforts with the Government of Iraq.

27. Page 18, 19, 51. Change Redistribution Property Accountability Teams to Retrograde Property Assistance Teams (RPAT).

28. Page 18. Delete. “No single organization has authority over Theater Property and Retrograde Support Teams.” Replace with: “AMC has Authority over Theater Property and Retrograde Support Teams.” The 402nd AFSB under the Army Sustainment Command/AMC is the C2 for all RPATs in Iraq. They also control RFATs (Redistribution Fly-away Assistance Teams), which remotely go where a permanent RPAT site is not located.

29. Page 20. Delete: “No Theater Logistical Organization has Command Authority over Units Responsible for the Retrograde of Most Equipment in Theater.” Replace with: “AMC has Command Authority over most units responsible for the retrograde of equipment in Theater.” The 402nd AFSB is responsible for retrograde in Iraq and the 401st AFSB is responsible for retrograde in Kuwait. All of these units fall under AMC/ASC and the AMC Forward Commanding General is also the ARCENT/CFLCC C4.

30. Page 19. The report states “For example, the Joint Redeployment Support Team, which reports to U.S. Transportation Command, has the mission of supplying customs, disposition, hazardous material, and transportation expertise to redeploying units and is to enable in-transit visibility over a unit’s materiel and equipment from its FOB to the unit’s home station or to an identified depot.” Comment: This statement implies that the JRST is executing its mission in the Iraq Theater of Operations. The concept of using JRSTs has not been executed because the capability already exists in theater with the Deployment Support Brigade. We recommend deleting this sentence.

See comment 36.

31. Pages 22-25. The section titled “Logistical Organizations Have Not Enforced or Lack the Authority to Enforce Improvements to the Retrograde Process (to include Appendix VI)” is not accurate. Recommend the entire section and Appendix be deleted from the GAO report. The correct automation flow is attached.



Retrograde Systems and Processes

- All items retrograded from Iraq have Radio Frequency Identification Device (RFID) tags attached; RFID tags provide in-transit visibility via an in transit visibility (ITV) system. The accountable record and visibility system used for this process is Standard Depot System (SDS), which is a standard wholesale system used by the Army. USCENTCOM’s RFID database can view the exact location of any item with an attached RFID tag at any time.
- The description of the process in this section of the GAO report is incorrect. Below is the correct process for accountability and visibility from the war fighter to AMC:
 - Unit creates Army Reset Management Tool (ARMT) plan in Logistics Information Warehouse (LIW) nominating equipment for RESET.
 - Logistics Support Activity (LOGSA) sends ARMT data electronically to life cycle management command (LCMC) for decision and disposition (DISPO).
 - If equipment meets RESET criteria, LCMC enters what depot to ship to.
 - Equipment is electronically transferred from PBUSE (Property Book Unit Supply Enhanced) to AWRDS (Army War Reserve Deployment System) via interface.
 - AWRDS generates a D6A (receipt) for SDS electronically via interface.
 - Site generates Excel spreadsheet of equipment for LCMC to obtain Inter-Depot Transfer (IDT) from Iraq to Kuwait.
 - Upon receipt of IDT, it is processed in SDS, and AWRDS creates RFID Tag.

- SDS is a standard accountability system as is Standard Army Retail Supply System (SARSS), and neither system tracks by serial number except for weapons and sensitive items. The Army War Reserve Deployment System (AWRDS) is used to track the serial number in tandem with SDS. AWRDS has automated interfaces with SDS, the wholesale system, and PBUSE (Property Book Unit Supply Enhanced) the retail system.
- AWRDS creates the document needed to provide the LCMC with a list of items that require disposition. SARSS can produce an automated request for disposition, but it still requires manual intervention by the LCMC item managers to provide disposition. The reason this is manual is the LCMC must determine where to send items for repair-based on available work load. This process takes 72 stateside work hours to complete.
- There is no loss of visibility of items being shipped out of Kuwait because the Global Transportation Network (GTN) has visibility of the RFID tags that are installed on all equipment. The IDT creates an automated Pre-Positioned Materiel Receipt Document (PMRD) on the gaining depot's SDS.
- Although the 401st AFSB obtains the shipping manifest, it is not required because all of the information on the items is available through GTN.
- The OPORD addressed in this section was published and released on 18 Apr 08 without proper coordination. Upon receipt of the OPORD, the 401st AFSB, 402nd AFSB, and LOGSA Commanders raised numerous concerns with using SARSS. During a teleconference between ASC and the commanders, the decision was made to put the OPORD on hold until a decision by the ASC commanding general (CG) could be made. The ASC CG tasked ASC Field Support to work jointly with LOGSA, AMC, LCMC's, 401st AFSB, and 402nd AFSB to review the proposed processes and resolve the concerns. On 23 Jul 08 a decision was made by the ASC CG to continue to use SDS and AWRDS, and a FRAGO was published to the OPORD.

See comment 37.

32. Page 23, 4th paragraph. We recommend rewording of this paragraph for clarity. In addition, that fact that the manifest does not reach the 401st until 24-48 hours after sail really is not an issue since the motor vessel will take at least three weeks to reach CONUS, leaving time for the CONUS teams to prepare to receive the materiel.

See comment 38

33. Pages 25-6, final paragraph, 1st sentence. Insert a period after "costly" and strike the rest of the sentence.

See comment 39.

34. Page 26, 1st full paragraph, 1st sentence. Insert a period after "estimate" and strike the rest of the sentence.

See comment 40.

35. Page 26, 1st full paragraph. Delete the second sentence.

See comment 41.

36. Page 26, 1st full paragraph. Delete “absent an agreement with Iraq on the disposition of personal property” and substitute therefore “absent a legal basis for turnover and agreement by Iraq to take possession.”

See comment 42.

37. Page 26, final paragraph. Delete the first sentence.

See comment 43.

38. Page 26, final paragraph, 2nd sentence. Delete “For example.”

39. Comments on SOFA (Comments 33-38 above). The draft report makes several assertions, both directly and by implication, relating to what is typically addressed in status of forces agreements (SOFA), and regarding what will or should be contained in a bilateral agreement with Iraq. The statements are inaccurate and misleading.

See comment 44.

SOFAs are the product of bilateral negotiations. Therefore, no two are the same, nor do any two contain the same provisions. In particular, “base closures” are not typically addressed in a SOFA (or related access agreement). A “typical” SOFA (or access agreement) might address the following: 1) DoD access to government-owned property, 2) DoD authorization to make improvements to such property, 3) DoD’s obligation to return the property, once no longer needed,; and, 4) consultation with the host nation at the time such property is returned regarding compensation for the residual value of any DoD-funded improvements to the property. It is relatively rare that a SOFA (or access agreement) will address in any detail the issue of “base closure” or estimates of costs of such closures or property returns. It also is noteworthy that SOFAs (and access agreements) are typically negotiated during peace time, and before DoD has any sizable presence and/or has been granted use of government property in the host nation.

See comment 45.

Bilateral agreements with Iraq are currently under negotiation. It would be inappropriate to speculate what might or should be in those agreements in this report.

Finally, there is no legal requirement for “an agreement with Iraq on the disposition of personal property.”

See comment 45.

40. Page 27. Regarding, “Joint doctrine states that detailed planning should be done for contracting support and contractor integration to ensure that contractor support is fully integrated and on par with forces planning. Such planning should identify sources of supplies and services from civilian sources and integrate them with operational requirements,” we partially concur with this statement. Joint doctrine regarding contract support and contractor integration is insufficient. The Joint Staff J4 is presently addressing this issue by developing Joint Publication 4-10 (Joint Operational Contract Support), which combatant commands, to include USCENTCOM, reviewed and commented on. This joint publication, when released, will present new doctrinal concepts that provide much improved guidance for integrating contract support and management of contractors into military plans. DoD contracting personnel generally are not planners, and DoD lacks sufficient operational contract support planners to ensure

contract support and contractor integration is effectively represented in plans. In December 2007, OSD began to address this issue by providing joint operational contract support planners (JOCSPs) to each of the combatant commands, including USCENTCOM. USCENTCOM has two JOCSPs that are reviewing concept plans (CONPLANS) and preparing Annex W's (Contract Support Integration Plan). In fact, USCENTCOM JOCSPs have been tasked by the Joint Staff J4 to develop an Annex W planning template for all of DoD's combatant commands. This template will eventually be incorporated into JOPEs and future editions of the JP 4-10 by the Joint Staff. Recommend changing statement to read as: *"Previous joint doctrine did not effectively provide guidance regarding contract support and contractor integration. However, DoD is addressing this with Joint Publication 4-10 (Joint Operational Contract Support). DoD contracting personnel are generally not experienced planners and combatant commands did not effectively integrate contract support and contractor integration into military plans. However, OSD recently addressed this issue by providing combatant commands with Joint Operational Contract Support Planners (JOCSPs). JOCSPs are developing contractor support integration plans and contractor management plans, and integrating them into the combatant commands plans."*

See comment 46.

41. Page 28-33. Regarding guidance and plans for reposture of contractors from Iraq, the draft GAO report states "As of July 2008, reposture planning did not include a theater-wide plan for the reposture of approximately 149,400 contractors in Iraq, more than half of whom (58%) were U.S. citizens or third country nationals. Reposture planning for LOGCAP is significant, given that it is the largest logistical support contract in Iraq. However, challenges remain in the planning for the reposturing of LOGCAP contractor personnel." We partially concur and provide the following:

- The LOGCAP contractor (KBR) has base closing Standard Operating Procedures (SOP) that will follow MNF-I and MNC-I base closure planning and includes plans for contractor personnel. KBR's SOP has been developed from previous base closings and updated with lessons learned.
- For planning integration, LOGCAP forward Liaison office (LNO) maintains a military officer at the Colonel level who focuses on MNF-I reposture planning groups; there is also a LNO in MNC-I C4 who facilitates theater reposture planning.
- For accountability, the LOGCAP contractor force protection issue is calculated throughout the reposture process as troop strengths are phased from the base.

See comment 47.

42. Concerning accountability and disposition of contractor managed government owned property, GAO states "According to DOD officials, the largest portion of all CMGO property in Iraq, \$3.37 billion (96%) falls under LOGCAP. The Army's analysis indicates that approximately 85% of all CMGO property in Iraq will be transferred, sold, or scrapped in Iraq when U.S. forces reposture, while the remaining 15% can be sold or

reused elsewhere. Three challenges remain: the need to determine FMV of CMGO and resolving any security restrictions, the time consuming & labor intensive task of accounting for and determining disposition of CMGO - transfer from contractor to military records, joint inventories, and DLA may not have sufficient data to adequately plan capacity at theater DRMOs)." We concur and provide the following: MNF-I FRAGO 08-232 published in May 08 includes CMGO property in its materiel disposition process, a CMGO FRAGO and MNC-I C4 FRAGO provides amplifying guidance on CMGO property, and while accountability of property is an on-going issue, progress is being made in improving the process and identifying excess materiel and equipment for reposture. DLA is also conducting on-site surveys of its four DRMO sites in Iraq, and it is included in the deliberate planning with reference to base closure and transfer.

See comment 48.

43. Page 29. Recommend adding the following sentences in quotes as an update to donation threshold authority. Several DoD organizations have already begun planning for the disposition of excess contractor-managed property from Iraq. For example, in October 2007, DoD increased the donation threshold for all excess U.S. owned personal property in Iraq from \$5,000 to \$10,000 and delegated this donation authority to MNF-I. Add the following: "In June 2008, DoD (DUSD, Logistics and Materiel Readiness) increased the authority to transfer (formerly known as donation authority) for all U.S.-owned excess personal property in Iraq from \$10,000 to \$15,000. This DoD memo is a tiered authority which provides commanders greater flexibility and more decision-making capability at their respective levels."

See comment 49.

44. Page 30, Figure 2. Recommend that the arrow labeled "sale" and pointed to "DRMS" be deleted. If an item is slated for sale or prepositioned stock, the sale will not cause the item to go the DRMS.

See comment 50.

45. Page 30, Figure 2. If an "over \$5000" item is not needed by military or contractors globally, there is an arrow showing it going to DRMS. However, the policy provides that before such an item would go to DRMS, an attempt will be made to donate the item to the Government of Iraq. This step needs to be included and shown in Figure 2.

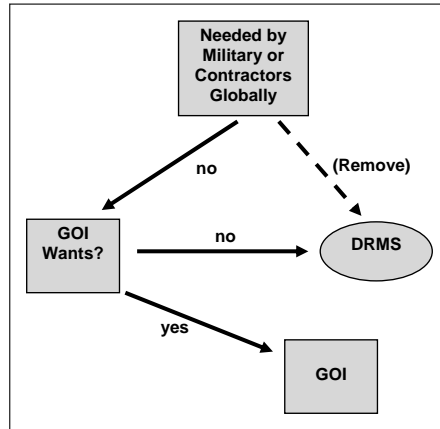

(Proposed change to Figure 2, Page 30)

See comment 51.

46. Page 30, Figure 2. Recommend that the box labeled “MNC-I determines others’ needs in theater” should be rewritten to state “MNF-I/MNC-I team determines others’ needs in theater.”

See comment 52.

47. Page 31. The report states that “DoD officials assert that completing this inventory will require planning, travel to storage locations, and physically staging the property for easier counting, which is time consuming.” However, the policy assumes that the inventory will take place where the property is and that property will not be moved and stored solely to enable inventory and counting actions. The policy does not envision movement and storage for counting and, in fact, specifies a streamlined process (i.e. early donations of low value items) to aid in minimizing time requirements. We partially concur that, in general, the task will be time consuming and labor intensive even without the additional movement and storage being asserted. While a move for counting may on occasion be necessary, depending on the number of days allowed to clear a base, it is expected to be the exception and not the rule.

See comment 53.

48. Page 53, paragraph 1. Entire statement is inaccurate: Please see attached slides. Below is the process for accountability and visibility from the War Fighter to AMC:

1. Unit creates ARMT (Army Reset Management Tool) plan in Logistics Information Warehouse (LIW) nominating equipment for RESET.
2. Logistics Support Activity (LOGSA) sends ARMT data electronically to the Life Cycle Management Command (LCMC) for decision and disposition.

3. If Equipment meets RESET criteria LCMC enters what depot to ship to.
4. Equipment is transferred from PBUSE (Property Book Unit Supply Enhanced) electronically to AWRDS (Army War Reserve Deployment System) via interface.
5. AWRDS generates a D6A (receipt) for Standard Depot System (SDS) electronically via interface.
6. Site generates Excel Spreadsheet of equipment for LCMC to obtain IDT Inter Depot Transfer) from Iraq to Kuwait.
7. Upon receipt of IDT it is processed in SDS, and AWRDS creates RFID Tag.

SDS is a standard accountability system, as is SARSS, and neither system tracks by serial number except for weapons and sensitive items. AWRDS is used to track the serial number in tandem with SDS. AWRDS has automated interfaces with SDS, the wholesale system, and PBUSE (Property Book Unit Supply Enhanced), the retail system.

See comment 54.

49. Page 54, paragraph 1. The AWRDS creates the document needed to provide the LCMC with a list of items that require disposition. SARSS can produce an automated request for disposition, but it still requires manual intervention by the LCMC item managers to provide disposition. The reason this is manual is the LCMC must determine where to send items for repair based on available work load. This process takes 72 stateside work hours to complete.

See comment 55.

50. Page 54, paragraph 2. Visibility over the items being shipped out of Kuwait is never lost, as the Global Transportation Network has visibility of the RFID tags that are installed on all equipment. The IDT (Inter-Depot-Transfer) creates an automated PMRD (Pre-Positioned Materiel Receipt Document) on the gaining depots SDS.

See comment 56.

51. Page 54, paragraph 3. Although the 401st AFSB obtains the shipping manifest, this is not required, as all of the information on the items is available through GTN.

See comment 57.

52. As a general comment, the Department has an exiting data sharing strategy (DoD Directive 8320.02, December 2, 2004) that provides policy responsibility to implement data sharing throughout the Department of Defense. Communities of interest, which have cross cutting data sharing interests, should be established when there is a need and should be used to implement viable solutions for data sharing strategies and solutions for their functional areas.

Retrograde Process Flow Using SDS/AWRDS

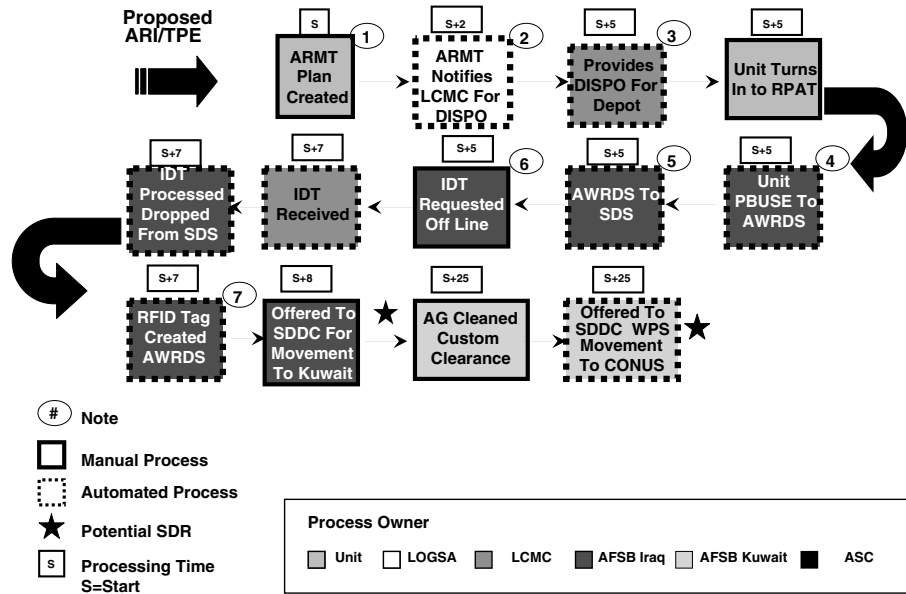

Retrograde Process Flow as Designed
(Continued)

1. Unit creates ARMT plan in LIW nominating equipment for RESET.
2. LOGSA sends ARMT data electronically to LCMC for decision and DISPO.
3. If Equipment meets RESET criteria LCMC enters what depot to ship to.
4. Equipment is transferred from PBUSE electronically to AWRDS via interface.
5. AWRDS generates a D6A (receipt) for SDS electronically via interface.
6. Site generates Excel Spreadsheet of equipment for LCMC to obtain IDT (Inter Depot Transfer) from Iraq to Kuwait.
7. Upon receipt of IDT it is processed in SDS, and AWRDS creates RFID Tag.

GAO's Responses to DOD's Technical Comments

Comment 1: We recognize DOD's retrograde efforts as of August 2008. No change required.

Comment 2: We are aware that subsequent to completing our audit work in Kuwait and drafting our report, CENTCOM refined the logistical command and control structure in June 2008 by placing the 401st and 402nd Army Field Support Brigades under the operational control of the commanding general, Army Materiel Command, Southwest Asia. Although we have not had the opportunity to evaluate the effect of this new command arrangement, we believe it to be a significant step toward the attainment of unity of command over the theater provided equipment retrograde process. However, CENTCOM has not implemented a similar action with regard to the command and control of the eight of the ten theater property and retrograde support teams that facilitate the redeployment and retrograde processes. According to ARCENT, this lack of unity of command over these teams makes their roles and responsibilities as they relate to the retrograde of equipment and materiel unclear and confusing. As a result, we continue to believe that DOD, in consultation with CENTCOM and the military departments, needs to immediately address the current confusion and lack of clarity regarding the command and control of the various commands and teams that support the retrograde operations in Iraq and Kuwait.

Comment 3: As we discussed in this report, five of the ten theater property and retrograde support teams assist units during the redeployment and retrograde process and in our report we briefly outline some of the actions for which they provide assistance in accordance with MNF-I's 180-day redeployment template (see table 1 of this report and the accompanying narrative). In addition, we provide more detail on each of the team's missions and higher headquarters in appendix IV of this report. No change required.

Comment 4: DOD commented that "The majority of equipment is organizational and will retrograde as a unit responsibility." However, according to DOD officials we interviewed during this engagement, and who have direct oversight over the property books, the majority of equipment in Iraq, some 80 percent, is theater provided equipment. No change required.

Comment 5: We recognize DOD is making efforts to improve In-transit visibility of materiel. No change required.

Comment 6: See comment 2. No change required.

Comment 7: Except where required for purposes of clarity and accuracy we have substituted the word “installation” or “installations” for “base” or “location.”

Comment 8: Based upon subsequent analysis and communication with subject matter experts, we updated the information in this paragraph to reflect new data.

Comment 9: Although DOD disagreed with GAO’s recommendation in the report in question, the intent of this reference is to provide for the reader a broader context in which the present report should be considered.

Comment 10: The purpose of the discussion regarding the National Defense Authorization Act for Fiscal Year 2008 is to provide background information about DOD’s reporting requirements and to demonstrate that, given the challenges to reposturing outlined in this report, Congress might elect to modify those reporting requirements.

Comment 11: During the course of this engagement we met with representatives from a variety of organizations in order to determine the extent to which DOD has begun its logistical planning for the reposturing of forces from Iraq (see appendix I, scope and methodology). Although it is possible that some preliminary discussions regarding reposturing, redeployment, or retrograde operations may have occurred prior to the time outlined in this report, based on our meetings with DOD officials, the documents they provided us, and our analysis we determined that planning for the reposturing of post-surge forces from Iraq began in the fall of 2007 and that those planning efforts were not coordinated until May 2008. No change required.

Comment 12: According to Army officials responsible for planning and executing convoy operations in Iraq and Kuwait, the number of HETs, convoy security assets, and crews to operate these assets were factors that limit the number of convoys that can be run given standard operating procedures current as of June 2008. The existence of potential mitigation strategies—such as using private security contractors, eliminating the requirement to provide security for low priority materials, and military units providing their own security—does not change the fact that the factors we outlined in this report remain limiting factors. No change required.

Comment 13: We recognize DOD's interests to increase mental health surveillance for returning service members. No change required.

Comment 14: We met with representatives from a variety of organizations several times over the course of this engagement either in person, telephonically, or by video teleconference (see appendix I, scope and methodology). As a result, we were able to obtain updated information that allowed us to discuss the means by which the logistical planning effort evolved over time. Based on these interviews and the information and documents we obtained during these meetings, our analysis indicates that despite working on the same broad set of issues, until late 2007 there was little coordination among Army Materiel Command, the Defense Logistics Agency, and Headquarters, Department of the Army. Moreover, according to CENTCOM officials, with whom we met in February 2008, they, too, were waiting on input from MNF-I, and, according to officials representing MNF-I, all discussion of reposturing was "close hold" in that headquarters until after the MNF-I commander's congressional testimony in April 2008.

Comment 15: To provide more details and context to the discussion, we changed the text to incorporate DOD's additional information.

Comment 16: See comment 15.

Comment 17: We agree that the logistical command and control arrangement is not a text book joint doctrinal command and control system. However, based on our analysis of joint doctrine and information obtained from officials in the organizations that were either directly responsible for the retrograde process or that negotiated the process, we determined that the resulting lack of a unified or coordinated command structure is not only inconsistent with joint doctrine, it also increases confusion and causes inefficiencies in the retrograde process and inhibits the adoption of identified mitigation initiatives. No change required.

Comment 18: For purposes of clarity, we deleted the footnote. As discussed in this report, CENTCOM has procedures in place regarding environmental management and property disposition during base closure/return. Furthermore, as we explain in this report, according to DOD officials responsible for executing environmental management and base closure/return in Iraq, these officials had not, as of May 2008, received guidance detailed enough to predict the time and cost requirements of executing the environmental management and property

disposition tasks that may be associated with base closure/return. See also comment 27.

Comment 19: See comment 18.

Comment 20: We believe that DOD comments 20 and 21 are duplicate comments, no change required; see comment 21.

Comment 21: We changed “standards” to “guidance.” See comment 27.

Comment 22: As DOD suggested, we deleted the footnote. See comment 18.

Comment 23: The sentence in question accurately reflects May 2008 statements made by ARCENT officials responsible for planning the potential environmental management of installations in Iraq that may be closed as a result of reposturing. No change required.

Comment 24: The sentence in question accurately reflects May 2008 statements made by ARCENT officials responsible for planning for both the potential disposition of personal property located on installations in Iraq and the potential environmental management of these installations. No change required.

Comment 25: The sentence in question accurately reflects May 2008 statements made by DOD officials responsible for planning for the potential disposition of personal property located on installations in Iraq.

Comment 26: The sentence in question accurately reflects May 2008 statements made by DOD officials responsible for planning for the potential environmental management of installations in Iraq. No change required.

Comment 27: We disagree with DOD’s comments that we made incorrect assertions about environmental remediation, that we made flawed assumptions regarding remediation, or that we have a misunderstanding of the department’s policies and practices. GAO is not making specific assertions regarding these issues. Rather, we are reporting that, as of May 2008, Army officials responsible for planning for logistical reposturing operations were considering these issues and that these considerations affected their planning. The information in this section accurately reflects May 2008 statements made by the Army officials responsible for both planning and executing environmental remediation operations in Iraq.

Moreover, according to CENTCOM guidance all hazardous material and waste is to be removed or remediated from installations in Iraq used by U.S. forces. In May 2008, ARCENT officials responsible for planning the potential environmental management of installations in Iraq stated that they had not received sufficiently specific guidance from their higher headquarters with regard to environmental remediation on installations in Iraq that may be closed as a result of reposturing. While they expected such guidance to be part of a future bilateral agreement between the U.S. and Iraq, the only guidance they could use for current planning purposes was the set of standards used in the U.S. for similar types of remediation practices. These officials explained that, in the absence of such guidance, it is common practice to use such U.S. standards when planning and executing environmental remediation of foreign installations used by U.S. forces. This explanation is confirmed by DOD's comment that "It is also longstanding Departmental policy to handle hazardous materials and waste in a manner that conforms to practice in the United States, to the extent feasible given the circumstances." These Army officials also explained that until they received such guidance on environmental remediation, they may have difficulty estimating the time and cost of cleaning these installations. In another comment on this report, DOD concurs, stating that the "time and cost of environmental management [of installations in Iraq] will be difficult to assess."

In regard to language used in the report, we have changed some terms for the purposes of clarity. We have changed "standards" to "guidance" and "status of forces agreements" to "bilateral agreements," where appropriate.

Comment 28: We changed "environmental cleanup" and "cleanup" to "management," where appropriate. See comment 27.

Comment 29: We updated figure 1 accordingly.

Comment 30: See comment 3.

Comment 31: See comment 18.

Comment 32: According to Annex D of MNF-I FRAGO 08-232, summary attached as Appendix IV of this report, RPAT(s) stands for Redistribution Property Assistance Team(s). No change required.

Comment 33: DOD maintains that Army Materiel Command has authority over theater property and retrograde support teams and lists one such team for which this is the case. We agree that AMC exercises command authority over two of these teams. However, according to documents obtained from ARCENT and MNF-I, there are ten such teams and command authority over these teams is distributed among various organizations (see appendix IV of this report). No change required.

Comment 34: See comment 2.

Comment 35: DOD contends that our statement about the Joint Redeployment Support Team implies that the team is executing its mission in the Iraqi theater of operations and that the concept of using this team has not been executed because the capability already exists in theater with the Deployment Support Brigade. However, in a briefing given during the May 2008 logistics summit at Camp Arifjan, Kuwait, ARCENT listed the Joint Redeployment Support Team as a team available to assist units and commanders with redeployment and retrograde of materiel and equipment, despite the fact that at the time of the briefing the team had not yet been sourced with personnel. In addition, in its Logistics Reposture Guidance (MNF-I FRAGO 08-232) MNF-I makes specific mention of the use of this team as it relates to redeployment and retrograde operations and delineates the specific mission for which this team is responsible (see appendix IV). In neither case is there any mention of the Deployment Support Brigade undertaking the mission outlined for the Joint Redeployment Support Team. No change required.

Comment 36: GAO has recently reported that DOD's Radio Frequency Identification (RFID) system is an emerging technology and continues to experience many implementation challenges. While not the focus of this report, DOD continues to experience issues with rates of error in the reading of RFID tags even while mandating the increased use of the tags. However, at this time, GAO does not believe that RFID is a reliable means for ensuring visibility over in-transit equipment and materiel.

We also recognize DOD's efforts to improve the in-transit visibility of supplies. Yet, the description of the retrograde process for theater provided equipment contained in this report is based on GAO's site visit to Kuwait in May 2008. The description was validated by the responsible subject matter experts at the 401st Army Field Support Brigade as accurately depicting the systems used to manage the equipment as well as the difficulties encountered during shipment. In addition, official emails and tracking documents indicated that significant amounts of equipment

were sitting idle in Kuwait awaiting disposition instructions. Moreover, in DOD's official comments to this report, they concur with our recommendation to correct the incompatibility weaknesses in the various data systems used to maintain visibility over equipment and materiel while they are in transit. DOD's general comments indicate that the process has changed and they provided us with a map of their proposed process as well as the July 23, 2008, order directing the use of Standard Depot System and Army War Reserve Deployment System to resolve issues with maintaining accountability and visibility and reducing the time for disposition instructions. However, this order will not be implemented until 8 September, 2008 and we have not yet been able to evaluate the effectiveness of the new process. No changes required.

Comment 37: See comment 36.

Comment 38: The sentence in question accurately reflects May 2008 statements made by Army officials responsible for both planning and executing installation hand-over operations. No change required.

Comment 39: According to CENTCOM policy, all bunkers, trenches, fighting positions, and force protection barriers are considered to be personal property and will be removed from installations. Additionally, in May 2008, DOD officials responsible for planning for the potential disposition of such property located on installations in Iraq stated that while they expected more specific guidance on the disposition of personal property to be part of a future bilateral agreement between the U.S. and Iraq, the only guidance they could use for current planning purposes was CENTCOM's policy. These DOD officials also explained that until they received more specific guidance on the disposition of such personal property, they may have difficulty estimating the time and cost of disposition. See also comment 27. No change required.

Comment 40: See comment 27.

Comment 41: The sentence in question accurately reflects May 2008 statements made by DOD officials responsible for planning for the disposition of personal property from installations. No change required.

Comment 42: The sentence in question accurately reflects May 2008 statements made by DOD officials responsible for planning for both the potential disposition of personal property located on installations in Iraq and the potential environmental remediation on these installations. No change required.

Comment 43: See comment 42.

Comment 44: See comment 24. In addition, with regard to the discussion of bilateral agreements, our report accurately reflects May 2008 statements made by DOD officials responsible for planning for both the potential disposition of personal property located on installations in Iraq and the potential environmental remediation on these installations. Moreover, GAO is not speculating on the potential existence or contents of any bilateral agreement(s) between the U.S. and Iraq, or any potential legal requirement for such an agreement. Rather, we are reporting that, as of May 2008, Army officials responsible for planning for logistical reposturing operations were considering that such an agreement(s) may exist in the future and that these considerations affected their planning. No change required.

Comment 45: We concur with DOD's assessment that CENTCOM did not effectively integrate contract support and contractor integration into its planning efforts for the logistics of reposturing. We also acknowledge that developing Joint Publication 4-10 and providing combatant commands with Joint Operational Contract Support Planners (JOCSPs) indicate potential progress in addressing the current challenges that CENTCOM faces in regard to effectively integrating contract support and contractor integration into its planning efforts. However, GAO has investigated neither the potential implementation of 4-10 nor the activities of CENTCOM's JOCSPs and thus cannot assess whether progress has been made in this area, or adopt the text suggested by CENTCOM. It is important to note that the paragraph DOD cites in this comment has changed due to subsequent communication between GAO and DOD subject matter experts. However, there is no change required in response to DOD's comment.

Comment 46: It is important to note that the paragraph DOD quotes in its comment has changed due to subsequent communication between GAO and DOD subject matter experts. However, we have three responses to this DOD comment. First, KBR is the LOGCAP contractor. Thus, while a KBR base-closure SOP may be useful in LOGCAP reposturing planning, its existence does not address the lack of theater-wide reposturing planning. The latter is CENTCOM's responsibility, not KBR's. Second, the LOGCAP program has had these two positions involved in reposturing planning since the Spring of 2008. While this coordination is facilitating LOGCAP reposturing planning, the challenges explained in our report existed despite this coordination. Third, our report did not address the specific issue of contractor force protection and so we cannot assess the

significance of such a calculation. There is no change required in response to DOD's comment.

Comment 47: We acknowledge DOD's concurrence. No change required.

Comment 48: Based upon additional information provided by DOD, we added the first sentence. However, we were not able to assess whether the memo is a "tiered authority which provides commanders greater flexibility and more decision making capability at their respective levels." We therefore did not add the second sentence.

Comment 49: For clarity purposes, we changed figure 2.

Comment 50: See comment 49.

Comment 51: See comment 49.

Comment 52: In this sentence, "travel" refers to officials traveling to sites in order to complete inventories, not to the travel of property. No change required.

Comment 53: See comment 36. No change required.

Comment 54: See comment 36. No change required.

Comment 55: See comment 36. No change required.

Comment 56: See comment 36. No change required.

Comment 57: We recognize DOD's existing data sharing strategy provides policy responsibility to implement data sharing through the department. No change required.

Appendix III: Department of Defense Classes of Supply

Class of Supply	Name	Explanation
Class I	Subsistence	Class I is subsistence materiel ranging from military-specification rations to commercial food items.
Class II	Clothing, Individual Equipment, and Tools	Class II is composed of organizational clothing and individual equipment, such as tentage and individual weapons; consumable items such as tools and administrative and housekeeping supplies; and industrial supplies such as cable, rope, screws, and bolts.
Class III	Petroleum, Oils, and Lubricants (POL)	Class III includes bulk and packaged POL; hydraulic and insulating oils, preservatives, bulk chemical products, coolants, deicing and antifreeze compounds, and components and additives of such products; and liquid and compressed gases, natural gas, coal, and electricity. Bulk fuel, the major Class III commodity, is propulsion fuel for aircraft, ships, and vehicles.
Class IV	Construction Materiel	Class IV includes all construction raw materials and fortification and barrier items such as lumber, wire, and sandbags.
Class V	Ammunition	Class V materiel consists of munitions of all types; bullets and projectiles, bombs, explosives, land mines, fuses, detonators, pyrotechnics, propellants, and their associated items.
Class VI	Personal Demand Items	Class VI materiel includes various nonmilitary health, comfort, and recreational items procured and managed by the Service exchanges, as well as Service morale, welfare, and recreation organizations.
Class VII	Major End Items	Class VII is composed of major war fighting equipment that constitutes the combat forces. Class VII includes ships, aircraft, missiles, tanks, launchers, and vehicles that are normally procured by the individual Service acquisition commands as part of major acquisition programs.
Class VIII	Medical Materiel	Class VIII consists of pharmaceutical, medical and surgical supplies and materiel, and medical equipment, including medical-specific repair parts, medical gases, blood, and blood products.
Class IX	Repair Parts	Class IX includes all repair parts, except medical equipment parts.
Class X	Materiel for Nonmilitary Programs	Class X items support nonmilitary programs such as economic and agricultural development, civic action, and various relief and education programs. Class X also includes any items that are not included under other classes.

Source: Joint Publication 4-09, Joint Doctrine for Global Distribution.

Appendix IV: Theater Property and Retrograde Support Teams

Team	Mission	Higher HQ and C2
Materiel Redistribution Team (MRT)	Conducts identification, documentation, and coordinates disposition and movement of excess class II, III(P), IV, VIII, and IX.	Direct Support to 316th Expeditionary Support Command; under tactical control of ARCENT through Task Force 586*
Redistribution Property Assistance Team (RPAT)	Facilitates the expedient turn-in of all excess Class VII Theater Provided Equipment (TPE), improves property accountability, and enables asset visibility of the received equipment.	Direct Support to 402nd Army Field Support Brigade; under tactical control of ARCENT through Task Force 586*
Defense Remediation Team (DRT)	Assists units in sorting and creating documentation for property during shipment and turn-in to a Defense Reutilization Marketing Office.	Defense Logistics Agency through the Defense Reutilization and Marketing Services Officer-in-Charge - Iraq
Deployment and Distribution Support Team (DDST)	Provides units in Iraq with Unit Movement Officer refresher course. Assists in building movement plans for organizational and RESET equipment, hazardous material documentation, blocking and bracing, and container safety inspections.	Surface Deployment and Distribution Command through the 840th Deployment Distribution Support Battalion
Joint Redeployment Support Team (JRST)	Facilitates the return of forces in order to reset combat capability for future operations. Combines and synchronizes the efforts of the other support teams to prepare accurate Joint Planning and Execution System data.	U.S. Transportation Command
Inventory Property Assistance Team (IPAT)	Tracks shortages and excess. Manages and maintains "virtual warehouses." Provides redistribution instructions and tracks redistribution; tracks operational needs statement, joint urgent operational needs statements and solutions for them.	Multi-National Corps-Iraq
Organizational Property Assistance Team (OPAT)	Coordinates for redistribution and facilitates the transfer of Department of the Army G3 (Operations) designated TPE and manages Category V listing published by DA.	Theater Property Book Officer (2nd Battalion, 402nd Army Field Support Brigade)
Reset Team	Provides unit training on Department of the Army/Army Materiel Command RESET program and Automated RESET Management Tool.	Army Materiel Command through the Army Sustainment Command and the 2nd Battalion, 402nd Army Field Support Brigade in Iraq
Reset Fly Away Team (RFAT)	Expedites RESET planning and shipping of Life Cycle Management Command specific priority RESET equipment.	Army Materiel Command through the Army Sustainment Command and the 2nd Battalion, 402nd Army Field Support Brigade in Iraq
Marine LOGCOM Retrograde Team (LRT)	Receives, stores, and prepares for shipment and redistributes excess principle end items to fill home station equipment shortfalls or to depots to be repaired for further redistribution to the operating forces.	Marine Corps Logistics Command (Forward)

Source: GAO analysis of Multi-National Forces-Iraq data.

*The MRTs and RPATs have a complex command. Both of these teams are sourced with Air Force Personnel under Task Force 586, an Air Force headquarters. However, both teams are under the tactical control of ARCENT, which exercises that tactical control through Task Force 586. Moreover, because the RPAT is in direct support to the 402nd Army Field Support Brigade in Iraq, Army Materiel Command also has some control over this asset which it exercises through its subordinate command, Army Sustainment Command.

Appendix V: Theater Logistical Infrastructure Throughput Model

Department of Defense (DOD) officials have developed a model that approximates the volume of equipment and materiel that can flow through the Iraqi theater of operations logistics infrastructure and the rate at which that infrastructure can sustain this flow.¹ In summary, the model states the theater logistics infrastructure can sustain the deployment and redeployment of no more than a total of five brigades' worth of equipment and materiel in and out of Iraq per month. Specifically, DOD has modeled two scenarios (see table 2, below). In the first, the deployment and retrograde of TPE and unit equipment and materiel are prioritized. In the second scenario, the deployment and retrograde of TPE and unit equipment and materiel are balanced with the retrograde of non-unit stocks, such as containers of supplies. In both scenarios, the 1st Theater Support Command can sustain the delivery of a certain amount of Class I (food, water) and Class III-B (packaged petroleum products such as motor oil) to forces in Iraq.

Table 2: Planning Scenarios for Sustained Deployment and Redeployment

Support logistics activity	Scenario one ^a	Scenario Two ^b
Sustainment of Forces in Iraq	7 sustainment convoys to and returning from Iraq, per day	7 sustainment convoys to and returning from Iraq, per day
Deploying Unit Equipment, Materiel	2.5 brigade equivalents, per month	2.0 brigade equivalents, per month
Redeploying TPE, or Unit Equipment, Materiel	2.5 brigade equivalents, per month	2.0 brigade equivalents, per month
Redeploying Non-Unit Theater Stocks	None	1.0 brigade equivalent, per month

Source: GAO analysis.

^aScenario one prioritizes the simultaneous deploy/redeploy flow of theater provided equipment, unit equipment, and materiel.

^bScenario two balances the simultaneous deploy/redeploy flow of theater provide equipment, unit equipment, and materiel with non-unit theater stocks.

According to DOD officials and documents, the model is based on three types of brigades: heavy or Stryker brigade combat teams (HBCT/SBCT); infantry brigade combat teams (IBCT); and separate brigades (BDE SEP). For each brigade type DOD planners compiled unit property book data, added an additional 20 percent to the equipment totals to account for theater provided equipment, and then used the resulting brigade types in detailed planning for key phases of the redeployment and retrograde process such as convoy and wash rack operations. According to DOD officials, in this manner they were able to approximate the redeployment

¹GAO did not verify the accuracy of this model.

and retrograde requirements and time frames for each type brigade. For example, the model assumes that a heavy or Stryker brigade combat team has almost twice the number of vehicles found in a separate brigade, and thus, requires almost 25 percent more convoys to retrograde these vehicles and almost double the amount of time on the wash racks.

Table 3: Key Planning Factors for Sustained Deployment and Redeployment, by Unit Type

Planning factors	Unit type		
	HBCT / SBCT	IBCT	BDE SEP
Vehicles in Unit	1,600	1,240	830
TEU (containers) in unit ²	170	220	270
Convoy packages	46	42	37
Wash rack days	7	5.5	4

Source: GAO analysis.

According to DOD officials, the predictive power of the rate-of-flow model is limited, and thus, it should not be used to calculate the minimum amount of time required to redeploy the total amount of equipment currently in Iraq. They explained that while the model assumes units are redeploying with a full set of equipment, the actual amount of equipment and materiel that needs to be transported, cleaned, inspected, and loaded onto ships will vary with each unit moving through the system. This means that in any given period of time, the actual amount of equipment and materiel being redeployed may be different than the amounts assumed in the model. For example, according to DOD officials, in the first quarter of fiscal year 2008 the theater logistical infrastructure was able to deploy an average of two brigades into Iraq and redeploy an average of three brigades out of Iraq each month. In addition, DOD officials have stated that during a period lasting about 1 month—from late November 2008 to early January 2009—four units will redeploy. They explained that this is possible because two of the units are leaving Iraq with only containers and the other two are redeploying with relatively little of their own equipment, having used mostly TPE while in theater. These two examples indicate that while the theater throughput model may provide planners with an estimate of the theater’s deployment and redeployment/retrograde

²DOD uses both military and commercial containers to ship and store supplies. Because most military containers are 20-feet long, and many commercial containers are 40-feet long, DOD uses 20-foot equivalent units (TEU) as a way to measure the total volume of containers in its inventory. One 20-foot container equals one TEU; one 40-foot container equals two TEU.

capacity, the model should not be used to predict the number of actual units that can redeploy during any 1 month period.

Appendix VI: Detailed Process for Shipping Excess Theater Provided Equipment

The current process for retrograding certain excess theater provided equipment (TPE) from Iraq is lengthy and does not maintain in-transit visibility. This is caused by the frequent manual manipulation of data. According to Department of Defense's (DOD's) Supply Chain Materiel Management Regulation, all DOD components shall structure their materiel management to provide responsive, consistent, and reliable support to the warfighter (customer) during peacetime and war.¹ In addition, DOD components are required to implement material management functions using commercial, off-the-shelf items or DOD standard data systems, as well as ensure timely, accurate in-transit asset information and maintain visibility and accountability over items in the pipeline.² Moreover, DOD components should implement and maintain supply chain material management systems to provide a timely and complete process.³

Figure 5 below describes the physical and data networks for Class VII TPE—including manual data transfers and key organizations—involved in the process.

¹DOD 4140.1-R, *DOD Supply Chain Materiel Management Regulation* Chapter 1, § C1.3.1.1, (May 23, 2003).

²See DOD 4140.1-R, § C1.3.1, § C1.3.2 and § C5.8.

³See DOD 4140.1-R, § C7.1.

Figure 5: Process for Retrograding Class VII Theater Provided Equipment

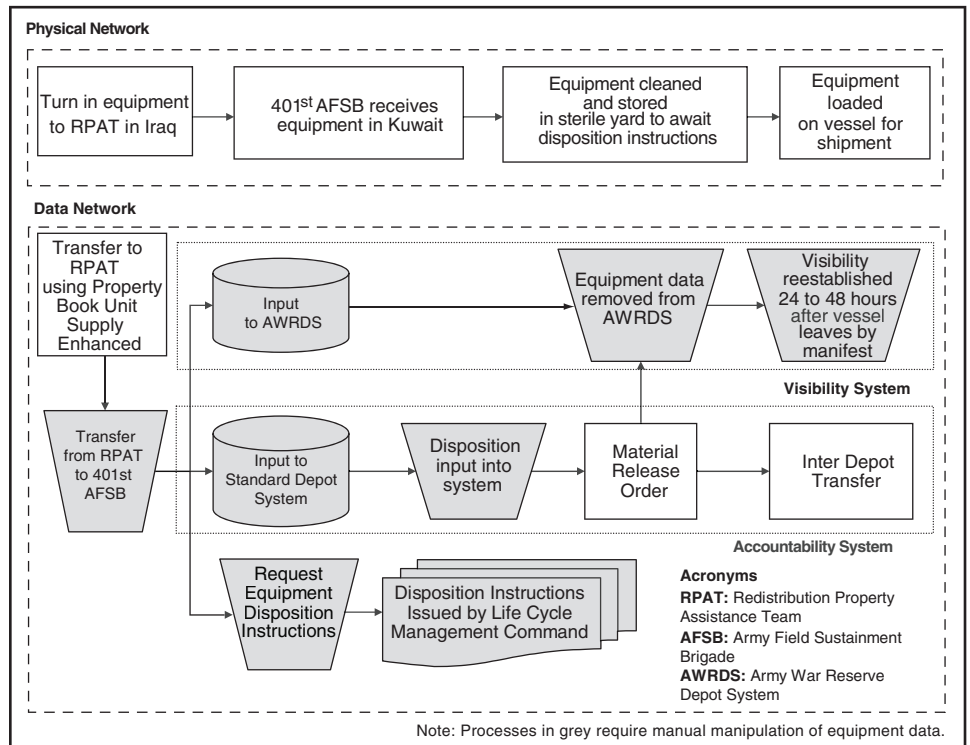

Source: GAO analysis of DOD data.

Currently, when Class VII theater provided equipment is transferred from the owning unit to one of the Retrograde Property Assistance Teams⁴ supporting the 402nd Army Field Support Brigade (AFSB) in Iraq, the accountability data for the equipment are transferred from the unit to the 402nd AFSB using the Army’s Property Book Unit Supply Enhanced system⁵ as shown in figure 5. Once the equipment moves to Kuwait, however, the 401st AFSB, which receives the equipment, must undertake two concurrent manual processes to establish accountability and visibility

⁴The Retrograde Property Assistance Teams (RPATs) facilitate the expedient turn-in of all excess Class VII, theater provided equipment (TPE), improve property accountability, and enable asset visibility of the received equipment. RPATs operate at six permanent locations throughout the theater Area of Operations (AO) to accomplish this mission.

⁵Army documents stated that the Property Book Unit Supply Enhanced is the Army’s Web-based property accountability system that provides real-time total asset visibility throughout all levels of Army management and secures transfers to the Standard Army Retail Supply System. Additionally, it is a Standard Army Information Management System.

for the equipment. Accountability is established by manually entering equipment data into the Standard Depot System (SDS). However, SDS tracks equipment by the total number of items, not individual serial numbers. Hence a second manual entry is made into the Army War Reserve Depot System (AWRDS) to provide visibility over each item by serial number. AWRDS—a non-standard Army information management system—was originally designed to provide visibility over Army pre-positioned equipment sets, but it has been modified to support SDS.⁶ This is contrary to DOD guidance that accountability and visibility should be established using standard data systems that share data.

Once accountability and visibility over the theater provided equipment have been established, brigade personnel request disposition instructions. This labor-intensive manual process involves sending spreadsheets populated with equipment data from Kuwait to Army Sustainment Command headquarters in Rock Island Arsenal, Illinois, and then on to the specific Life Cycle Management Commands⁷ responsible for each particular item who, in turn, send disposition instructions back through this chain to the 401st AFSB. This process can take months or years because of the manual workarounds used to pass and manipulate the data.

Once disposition instructions are received in Kuwait, equipment can be shipped; however in-transit visibility of the equipment is temporarily lost. When disposition instructions for a certain item of TPE are received, that item drops from the AWRDS database and uses a process called Inter-Depot Transfer to manage shipment of that item. By dropping the item from AWRDS, however, the 401st AFSB loses visibility over the item, because Inter-Depot Transfers are not entered into the Global Transportation Network, DOD's system for providing near real-time in-transit visibility information. This lack of in-transit visibility is contrary to current DOD guidelines to maintain timely, accurate visibility over items in the distribution pipeline.

⁶Army documents state that Standard Army Management Information Systems provide a seamless and inoperable network of logistics systems using integrated communication tools.

⁷The Army Materiel Command has five Life Cycle Management Commands, each of which is responsible for certain types of equipment. They are: Aviation and Missile, Chemical Materials Agency, Communications-Electronics, Joint Munitions & Lethality, and Tank-automotive & Armaments Command.

The 401st AFSB uses another manual process to compensate for this by coordinating with Surface Deployment and Distribution Command elements at Kuwaiti ports in order to obtain final load manifests for each vessel. The manifest is then forwarded to the appropriate Life Cycle Management Command in the United States so that item managers there can prepare for the receipt of the equipment; however this information does not reach the 401st AFSB until 24 to 48 hours after a vessel sets sail.

Appendix VII: GAO Contact and Staff Acknowledgments

GAO Contact

William M. Solis (202) 512-8365 or solisw@gao.gov

Acknowledgments

In addition to the contact named above, David A. Schmitt, Assistant Director; Guy A. Lofaro, Analyst in Charge; John Lee; Katherine Lenane; Gregory Marchand; John J. Marzullo; Tristan T. To; Christopher Turner; Cheryl Weissman, and Kristy Williams made key contributions to this report.

GAO's Mission

The Government Accountability Office, the audit, evaluation, and investigative arm of Congress, exists to support Congress in meeting its constitutional responsibilities and to help improve the performance and accountability of the federal government for the American people. GAO examines the use of public funds; evaluates federal programs and policies; and provides analyses, recommendations, and other assistance to help Congress make informed oversight, policy, and funding decisions. GAO's commitment to good government is reflected in its core values of accountability, integrity, and reliability.

Obtaining Copies of GAO Reports and Testimony

The fastest and easiest way to obtain copies of GAO documents at no cost is through GAO's Web site (www.gao.gov). Each weekday, GAO posts newly released reports, testimony, and correspondence on its Web site. To have GAO e-mail you a list of newly posted products every afternoon, go to www.gao.gov and select "E-mail Updates."

Order by Mail or Phone

The first copy of each printed report is free. Additional copies are \$2 each. A check or money order should be made out to the Superintendent of Documents. GAO also accepts VISA and Mastercard. Orders for 100 or more copies mailed to a single address are discounted 25 percent. Orders should be sent to:

U.S. Government Accountability Office
441 G Street NW, Room LM
Washington, DC 20548

To order by Phone: Voice: (202) 512-6000
TDD: (202) 512-2537
Fax: (202) 512-6061

To Report Fraud, Waste, and Abuse in Federal Programs

Contact:

Web site: www.gao.gov/fraudnet/fraudnet.htm

E-mail: fraudnet@gao.gov

Automated answering system: (800) 424-5454 or (202) 512-7470

Congressional Relations

Ralph Dawn, Managing Director, dawnr@gao.gov, (202) 512-4400
U.S. Government Accountability Office, 441 G Street NW, Room 7125
Washington, DC 20548

Public Affairs

Chuck Young, Managing Director, youngc1@gao.gov, (202) 512-4800
U.S. Government Accountability Office, 441 G Street NW, Room 7149
Washington, DC 20548