

UNCLASSIFIED
CONFIDENTIAL

DEPARTMENT OF DEFENCE

AR-001-195

DEFENCE SCIENCE AND TECHNOLOGY ORGANISATION

ELECTRONICS RESEARCH LABORATORY

TECHNICAL MEMORANDUM

ERL-0014-TM

DEVELOPMENT OF A SMALL HIGH PERFORMANCE
THERMAL INFRARED DETECTION AID

K.C. Liddiard, M.Sc., MAIP

S U M M A R Y

This Memorandum describes the proposed development of a small, lightweight thermal IR detection aid, capable of operation as an IR intrusion sensor, a thermal pointer and a man-portable thermal imager.

Distribution:

Approved for Public Release

Chief Superintendent,
Research Centre

POSTAL ADDRESS : The Chief Superintendent, Electronics Research Laboratory,
G.P.O. Box 2151, Adelaide, South Australia, 5001.

UNCLASSIFIED
CONFIDENTIAL

TABLE OF CONTENTS

	Page No.
1. INTRODUCTION	1 - 2
2. PERFORMANCE REQUIREMENTS	2
2.1 Detection of human targets	2 - 3
2.2 Intrusion sensors	3 - 4
2.3 Thermal pointers	4
2.4 Sentry detection aids	4 - 6
2.5 Low flying aircraft detection	6 - 7
2.6 Maritime surveillance	7 - 8
2.7 Submarine IR periscope	8
2.8 Sensor performance specifications	8 - 9
3. PROPOSED THERMAL IR DETECTION AID	9
3.1 Optical system	9 - 10
3.2 IR detector array	10 - 11
3.3 Vertical scan	11
3.4 Horizontal scan	11 - 12
3.5 Electronics	12
3.6 Output displays	12
3.6.1 Thermal pointer display	13
3.6.2 Imaging display	13 - 14
3.6.3 Intrusion alarm	14
4. CONCLUSIONS AND RECOMMENDATIONS	14 - 15
5. ACKNOWLEDGEMENTS	15
REFERENCES	16 - 17

LIST OF APPENDICES

I. PERFORMANCE OF ERL THERMAL INFRARED DETECTORS	18
I.1 Metal film bolometer detectors	18 - 19
I.2 Detector research programme	19
I.3 Detector performance predictions	20 - 22

UNCLASSIFIED
CONFIDENTIAL

LIST OF TABLES

Page No.

- | | |
|--|----|
| 1. PERFORMANCE OF ERL METAL FILM BOLOMETER DETECTORS | 18 |
| 2. IR SENSOR PERFORMANCE | 21 |

LIST OF FIGURES

1. Thermal IR detector array
2. Thermal IR detection aid schematic

UNCLASSIFIED
CONFIDENTIAL

UNCLASSIFIED
CONFIDENTIAL

ERL-0014-TM

1. INTRODUCTION

During recent years a number of problem areas in military IR detection have been referred to Night Vision Group, ERL, for comment or assessment. In many instances these enquiries have led to specific requests to carry out target signature measurement and analysis; and hence to define the characteristics of the target and recommend solutions to the military problems presented.

Some typical defence tasks which fall into the broad category of military IR detection are as follows:

- (a) IR intrusion sensing, in military field applications
- (b) Thermal pointers, used in conjunction with pure optical or low-light-level devices
- (c) IR target location and weapon aiming
- (d) Sentry detection aids
- (e) Low altitude aircraft detection
- (f) Airfield perimeter surveillance
- (g) IR intrusion sensing, in inshore maritime surveillance
- (h) Target detection and recognition, FPB counter-insurgency operations
- (i) Fisheries surveillance
- (j) Submarine periscope IR detection systems

Obviously, this list is not exclusive. No mention is made, for example, of airborne IR imaging, general battlefield surveillance and long range maritime surveillance. These are the domains of high performance FLIR systems and line scanners.

At first sight, the above tasks are seemingly unrelated, for they are associated with a variety of Service requirements, each represented by different target characteristics, backgrounds, detection ranges and atmospheric transmission. However, a closer examination will show that there are areas of similarity, sufficiently related to justify further investigation. Firstly, in most cases there is a relatively well defined search area, e.g., a horizon scan, field sector, infiltration route, etc., and this suggests a common field of view in at least one direction. Secondly, the detection devices are required to be small, lightweight and compact; and, with obvious exceptions, they must be field portable. Thirdly, target ranges are usually short, and where this is not the case, the targets are either large and/or are strong IR sources. Fourth, it is generally true that the detection systems must be low cost equipments if they are to be militarily viable. Fifth, it follows that high performance FLIR systems are often not suitable for the selected tasks on grounds of weight, size and cost; and in any case the inherent FLIR sensitivity and resolution may not be required.

Obviously, there is no single IR detection system which can perform all of these tasks. Nevertheless, it may be argued that there is considerable merit in pursuing the development of a detection device which is designed to meet a specific requirement, but can be adapted to other roles. We thus postulate that there is an important group of military IR detection tasks which are linked by a common technology; for which there are currently no satisfactory or cost-effective solutions, and which are amenable to treatment on the modular design concept. Modular construction is becoming widely accepted overseas for

UNCLASSIFIED
CONFIDENTIAL

UNCLASSIFIED

FLIR systems, and is particularly suited to Australian development for reasons of efficiency and cost.

Thermal IR detector research and IR systems technology at ERL has progressed to the stage where consideration can be given to practical applications in field equipments. This report proposes an R&D project specifically intended to achieve the following objectives :

- (i) to develop a small IR detection aid, capable of performing in various modes of operation: as an IR intrusion sensor, a thermal pointer, a lightweight (man-portable) thermal imager; and
- (ii) from experience gained in development and field trials, to determine acceptable forms of data displays, assess potential military roles, and establish design parameters for IR Detection Aid devices to meet specific Service requirements.

Four distinct development phases are recommended, as outlined in Section 4.

It is proposed that the IR detection aid should be constructed on a modular basis to permit interchange of components for field evaluation. In particular, the sensor assembly, comprising optics, detector and signal amplifier, would be common to all modes of operation. However, the initial experimental design should be aimed at the development of a basic instrument having well defined performance parameters, e.g., sensitivity, scan rate, resolution and overall field of view, determined from a realistic assessment of military requirements.

2. PERFORMANCE REQUIREMENTS

It is now desirable to review briefly the performance and design limitations required to meet the military tasks discussed in Section 1, in order to establish parameter guidelines for the construction of an experimental IR detection aid.

2.1 Detection of human targets

The detection of personnel in the military environment is dependent on a number of parameters, the most important being the radiation characteristics of the various regions of the human body and the extent to which they are exposed, the nature of the background, the type of clothing, and climatic conditions. Numerous measurements of these target/background characteristics have been made using recording radiometers and thermal imagery, and this data provides a good basis for seeking the performance requirements for a wide range of military situations.

The exposed regions of the human body are normally the strongest targets, especially the face, which may attain an apparent blackbody temperature difference of 15 to 20 K measured against a uniform, isothermal background (see reference 1). This temperature difference would, however, be typical of cooler climates, and the wearing of heavy clothing may then be expected to give torso temperatures of less than 5 K. On the other hand, facial temperature differences are of the order of 5 to 10 K in tropical environments, and are not greatly different to the torso values (chest, back, thigh), because of the light clothing worn in this climate.

UNCLASSIFIED
CONFIDENTIAL

CONFIDENTIAL
UNCLASSIFIED

ERL-0014-TM

The nature of the background also has a strong influence on the detectability of human targets. The best viewing conditions are during the night, or in totally shaded areas during day, when background temperature variations are small. Conversely, target backgrounds which are partially shaded or fully illuminated during the daytime, may have temperature variations comparable to the human target/background differential. The background thermal pattern can be extremely complex, acting in effect as a natural camouflage for a stationary target.

Finally, it should be noted that the integrated (broadband) atmospheric transmission, for targets at ambient temperature, falls rapidly over the first 100 m of the transmission path. In temperate climates, the transmission will be of the order of 0.4; whilst in tropical climates, the magnitude of the transmission is approximately 0.35 over 100 m, and 0.25 over 500 m (ambient conditions, no precipitation).

In summary, we may expect that a target temperature differential of 4 K and an atmospheric transmission over 500 m of 0.25 will represent a "worst case" detection criterion under conditions of moderate meteorological visibility. Thus, as a general guide, a broad-band IR detection system must be capable of measuring a zero range minimum detectable temperature difference (MDT) of ~1 K, in order to detect a human target under varying scenarios, at ranges up to 500 m. Further, the instantaneous detector field of view must be sufficiently small to resolve the target at a given range.

Resolution requirements for IR detection of human targets are treated in depth in reference 2. For the purpose of this study, if we assume a specification of two resolution elements for a 1 m target size, then the limiting angular resolution of the detection system must be approximately 5 mrad for detection of a standing man at 100 m range and 1 mrad at 500 m range. If the face only is exposed, the limiting resolution needs to be 1 mrad at 100 m range and 0.2 mrad at 500 m range. Note that this result applies to detection only, and a much higher resolution is necessary for recognition and identification.

Beyond the range where the target is fully resolved, the required MDT will fall off with the inverse square of the range.

2.2 Intrusion sensors

During 1973 a preliminary assessment was made at ERL of a small passive IR intrusion sensor capable of detecting a moving erect man at 100 m range and a crawling man at 50 m range (ref.3). The device was required to have a remote readout, with multichannel capability and signal reception at a range of 1500 m from the sensor. This would appear to be a realistic specification.

It follows from the data given in Section 2.1 that an IR intrusion sensor meeting the above specifications should have an MDT of 1 to 2 K and limiting angular resolution of approximately 2 mrad to detect a partially concealed man at 50 m. It would seem desirable, on the grounds of simplicity, to employ a single detector with an instantaneous field of view of perhaps 20 to 40 mrad vertical and 2 mrad horizontal. However, a preferred arrangement is an array of detectors, each having a field of view of 2 mrad, and a total vertical view of 75 to 100 mrad (approximately 5°). This would ensure detection when only small areas of the target are

CONFIDENTIAL
UNCLASSIFIED

- 4
CONFIDENTIAL
UNCLASSIFIED

exposed, and provides a wider coverage of the target field. The use of multiple detectors also offers greater potential for false target rejection. This is a common problem with intrusion sensors, because of the static 'staring' mode of operation, and the possibility of false alarms due to background fluctuations.

An intrusion sensor is essentially a simple alarm device, designed to trip whenever a target enters the detector field of view. The intrusion indicator may be visual (a lamp or electrical meter), audio (an earplug) or tactile. For a remote alarm, the sensor signal must also be in an appropriate form for on-line or off-line transmission. In both cases, the sensor unit is required to be compact, rugged and fully field portable, with a battery life of several hours.

2.3 Thermal pointers

A thermal pointer is required to give a positional (point) location of a thermal target within a specified field of view. The pointer output is optically coupled to a low-light-level device, so that a target detection appears as a spot of light on the image intensifier screen. Positional indication is generated by vertically scanning the field of view of the IR detector, accompanied by the panning action during normal horizontal search. The thermal pointer can thus be thought of as a scanning intrusion sensor.

A variation of the above technique is to display the pointer output as a vertical LED array mounted in a conventional telescope. This is an attractive proposition for daylight viewing or night operations down to moonlight level. To the author's knowledge, this technique has not previously received detailed attention. In any case, the thermal pointer is well suited to target location applications and offers the possibility of a low cost weapon aiming device.

Since the thermal pointer must be capable of locating targets which may otherwise be difficult to detect with the associated viewing device, the performance specification is more severe than that required for a simple intrusion sensor. We have seen that if human targets are to be detected at ranges of the order 100 to 500 m, the sensor MDT must be ≤ 1 K and the limiting angular resolution ≤ 1 mrad. The total vertical scan of the thermal pointer should be 5° to 10° , depending on the overall field of view of the associated viewing device (the field of view of a Starlightscope is 10° , and of 7 x 50 binoculars, 7°). The horizontal scan would be $\geq 5^\circ \cdot s^{-1}$, corresponding to a typical binocular search rate.

Given these performance specifications, the thermal pointer should be capable of detecting large military vehicles (trucks, tanks, etc.) at a range of at least 1 km.

2.4 Sentry detection aids

The Sentry Detection Aid, as proposed by the Australian Army, is a small, lightweight, man-portable IR detection aid, for use by individual personnel engaged on sentry duty. The device is primarily intended for the detection of human targets and would be employed in conjunction with a low-light-level viewing aid. The concept is essentially that of a thermal pointer which is not directly coupled to the associated night viewer.

CONFIDENTIAL
UNCLASSIFIED

CONFIDENTIAL
UNCLASSIFIED

Army Staff Requirement 24.4 of 1976 gives a specification for a proposed Sentry Detection Aid(ref.4). As a broad statement it may be said here that there must be a compromise between performance, complexity and cost; and a further study would seem desirable in order to determine more precisely the manner in which the detection aid will be used in practical situations (in particular, to assess the most suitable form of readout).

The basic target acquisition specification called for in ASR 24.4 is the detection and localisation of a kneeling man at a minimum range of 400 m. It follows that a sensor unit having an MDT >1 K and limiting angular resolution >1 mrad is unlikely to meet the specification. This requirement is in fact beyond the capability of devices such as the AGA Thermovision, a well known commercial thermal imager, which has an instantaneous detector field of view of 3 mrad. Furthermore, a simple intrusion alarm device, which has the desired sensitivity and resolution, would probably be unacceptable because of a high false alarm rate (100% detection is specified in the ASR). These observations are based on practical field evaluations carried out by ERL, and on reported experience of U.K. and U.S.A. workers in the development of the thermal pointer and beam break sensors.

The method of deployment has a strong bearing on the acceptable design for a Sentry Detection Aid. Thus a higher performance device, more closely meeting Army requirements, may be required by sentries guarding defended perimeters, i.e., base security. This could mean simply the ability to use a rudimentary scanner unit mounted on a tripod, and a lightweight target display. On the other hand, a patrol sentry, operating long distances from a support base, would require a small device of extreme simplicity and ease of operation; and this will almost inevitably demand a performance trade-off in one way or another.

After careful deliberation, and with due regard to the extensive data accumulated in various field experiments and exercises (see, e.g., reference 5 and Surveillance Working Papers listed in reference 6) the author believes that an acceptable sensor specification for a Sentry Detection Aid is:

MDT	1 K
Resolution	1 mrad
Vertical field	5° - 10°
Horizontal scan	5°.s ⁻¹ min

As stated above, a thermal pointer style sensor unit, fitted with a simple output alarm, will be prone to false alarms. It is considered that a more satisfactory approach is to design a sensor system incorporating:

- (a) a miniature imaging display (base security display);
- or
- (b) a LED array, preferably adapted to a night telescope (patrol sentry display).

It will be noted that these techniques provide the sentry with a degree of independence; e.g., in case (a) an image intensifier may not be required for target classification, and in case (b), the telescope is available for normal visual surveillance. Further, an appropriately designed sensor unit would be employed for both purposes, and might also be used as an intrusion sensor.

UNCLASSIFIED

- 6 -
UNCLASSIFIED
CONFIDENTIAL

The telescope display is of course, a true thermal pointer. If the LED array is fabricated in the form of a 'graticule' interposed in a focal plane, it should also be readily adapted to an image intensifier.

Human factors will play an important part in the determination of a Sentry Detection Aid design specification. Thus, experience gained with infantry units indicates that soldiers engaged on patrol activities, or on individual (non-supported) sentry duty, prefer not to have any encumbrance which may impair hearing. Accordingly, unless a sentry is supported by other fully alert soldiers, headphone or earplug alarm devices are likely to be unacceptable. Visual displays are acceptable, provided they enhance detection capability and do not impair natural vision. Surveillance devices must also be small, lightweight, compact, easily operated, and must inspire user confidence. Their value is likely to be measured in terms of an equivalent weight of ammunition or field rations.

The Sentry Detection Aid has been considered in some depth, because of the wide implications this concept may have in military surveillance applications. It is conceivable that a thermal IR detection aid, which is constructed specifically to meet a sentry detection aid specification, can be adapted on a modular basis to fulfil a number of allied roles of military importance. Conversely, it is equally conceivable that the adoption of a simplistic and narrow design concept may lead to the procurement of a device whose application is limited, perhaps even for the intended role.

2.5 Low flying aircraft detection

We consider here the detection of aircraft flying at low altitude towards a defended ground position. There is now sufficient target data available to indicate that an IR sensor having an MDT of 1 K and resolution of 1 mrad should be capable of detecting such aircraft at a range of 5 km. A total vertical field of view of 5° is adequate, and for a fixed intrusion-alarm style sensor, 2° may be sufficient. The above specification for a sentry detection aid will thus meet this requirement.

However, the horizontal scan requirements for low flying aircraft detection needs careful consideration, and this aspect has been considered in detail in reference 7. Briefly, if the aircraft speed is ≥ 500 knots, the elapsed time from the maximum detection range to the ground position is only 15 to 20 seconds. If it is assumed that a minimum period of 10 s is needed to direct weapons towards the aircraft, then a detection must be achieved within 5 s, and desirably two or three additional detections during the same period to ensure a low false alarm rate. Thus for an all-round alert capability, the horizontal scan rate should be 180 to $360^\circ \cdot s^{-1}$. At this scan rate, a vertical field of 2° would barely be achieved using a single cooled CMT detector; and indeed, since the vertical coverage of an all-round alert system would need to be much larger to accommodate variations in the terrain, a multi-element array of such detectors is required.

On the other hand, if a sector scan is acceptable, e.g., if the general direction of the threat is defined, then a horizontal scan rate of 20 to $40^\circ \cdot s^{-1}$ would provide coverage for a 45° arc. A sector scan may well have a wide application, since a single all-round sensor is conceivable only for flat terrains.

UNCLASSIFIED
CONFIDENTIAL

CONFIDENTIAL
UNCLASSIFIED

ERL-0014-TM

Finally, the IR sensor must be coupled to an audible and/or visual alarm device. If the sensor output can be adapted to a small imaging display, as discussed in Section 2.4, the same sensor can be used for allied roles, e.g., airfield perimeter surveillance and ground control of friendly aircraft at night.

2.6 Maritime surveillance

IR detection in the marine environment will, in general, demand longer target detection ranges compared to military applications. However, the background is more uniform, targets may be larger, and source temperatures are often high.

The problem of maritime surveillance in the special case of inshore and counter-insurgency operations is discussed in reference 8. A number of studies of marine targets have been carried out by ERL and a comprehensive list of papers published prior to 1974 in the general field of night vision is given in the above reference. More recently, activities have included participation in Exercise WARM WATERS (1974, (ref.9)) and IR scanner trials (1975-77, (ref.10)).

The particular areas of interest considered here are the detection of small craft and patrol vessels, landing and boarding operations, air-sea rescue, inshore navigation, and unattended (remote) intrusion sensing. More recently, the peacetime problem of fisheries surveillance has become of national importance, and this can be added to the list of applications.

Since the size of passive targets will be at least 2 m (e.g., the breadth of small craft), sensor resolution for ranges up to at least 2 km will again be the order of 1 mrad. The thermal contrast of hulls, exposed reefs, etc., although high during the day, are nevertheless still significant during the night, as shown by recent sea trials (ref.10). Hot sources such as funnels and outboard motors have been found to enhance detection ranges considerably; and passive targets are still detectable because of differences in emissivity. Furthermore, human targets will generally be acquired at longer ranges than in the military environment. It has been concluded that an MDT of 0.5 to 1 K, combined with 1 mrad resolution, will ensure good performance for small marine targets. This conclusion is based on analysis of actual signature data.

The above considerations were adequately demonstrated during Exercise WARM WATERS (ref.9). The detection range of small craft, using the AGA Model 661 Thermovision system, varied from 700 to 1200 m, depending on size (the largest target was a 20 m long fishing boat). The targets were mainly viewed from astern, and analysis of the trial records clearly showed that the range performance fell off rapidly when the target no longer filled the detector field of view, as expected from the $1/R^2$ law. For the larger targets, the 'critical' range was of the order of 700 to 1000 m, and detections beyond this range were due to active sources such as the engine exhaust. Of particular interest is that a Gemini dinghy, a vessel widely used in covert operations, was detectable at similar ranges to the larger vessels, and well beyond NOD range, presumably because of the exposed personnel and outboard motor.

Recent sea trials (ref.10) have provided considerable additional evidence of the ability of IR detection systems to detect small marine targets, including underwater swimmers (Operation AWKWARD) and personnel engaged in landing operations.

CONFIDENTIAL
UNCLASSIFIED

UNCLASSIFIED
CONFIDENTIAL

The AGA Thermovision has an MDT of ≤ 1 K and limiting angular resolution of 3 mrad. With other factors, e.g., atmospheric transmission, taken into account, it is expected that a sensor having the same MDT and a resolution of ≤ 1 mrad would achieve a detection range for similar targets of 2 km.

The total vertical field of view of an inshore IR detection device should be 5 to 10°, and the horizontal scan should be at least 5°.s⁻¹. A larger horizontal scan rate, i.e., a large horizontal field and/or fast frame rate, may be required in some applications. In general, an imaging display will be required; however, thermal pointer style devices are not excluded.

A ship-mounted detection system will almost certainly need to be image stabilised, and the overall sensor system must be small, robust and lightweight if FPB application is envisaged. It is anticipated that the small IR detection aid considered in this proposal could be adapted to such a requirement. It is expected that the all-up weight of the detector head assembly would be roughly 1/5 of a high performance stabilised FLIR system, and the volume would be smaller by a factor of 8 to 10. No cooling is required for the detector.

2.7 Submarine IR periscope

This application was briefly discussed in reference 11. The basic conclusions reached in the feasibility study are still valid, namely that a sensor comprising a linear array of 100 uncooled detectors, each having an instantaneous field of view of 1 mrad, an MDT of 1 K and an overall vertical field of 6°, should be capable of detecting surface shipping under poor imaging conditions (good visibility, but low target temperature differentials) at ranges in excess of 5000 m. The maximum expected range would be approximately 5 km. Low flying aircraft should be detectable at similar ranges.

A major problem in this type of system was found to be the sensor window and this remains true. It is now believed that the horizontal scan rate of 10°.s⁻¹ proposed in the feasibility study could be increased for the same number of detectors, or maintained with less detectors. The scan is achieved by rotating the periscope, and the sensor is essentially an imaging system with the display mounted in the control room. Data can be stored on video tape for subsequent replay and evaluation.

2.8 Sensor performance specifications

The above discussion allows us to arrive at a broad design specification for an experimental IR detection aid. Firstly, it is clear that the minimum acceptable sensitivity and resolution requirements are :

- | | |
|---|----------|
| (a) Minimum detectable temperature difference (MDT) | 1.0 K |
| (b) Angular resolution | 1.0 mrad |

The MDT has been specified for targets which just fill the instantaneous detector field of view. This parameter is in fact a function of target size. When the target size exceeds the detector field of view, the MDT may decrease slowly with increased target size, as a consequence of the pattern recognition capability of the human eye. The MDT increases rapidly when the target is no longer resolved, in accordance with the 1/R² law. A further parameter, noise equivalent temperature difference (NET), is required to establish the detector performance specification.

UNCLASSIFIED
CONFIDENTIAL

NET is defined for large area target sources, and the relationship to MDT is complex. Experience has shown, however, that for targets which just fill the detector field of view, a high detection probability should be obtained when $NET \approx 0.25$ MDT. Noting that the maximum acceptable MDT is 1.0 K, we will require :

(c) Noise equivalent temperature difference (NET) 0.25 K

We have seen that the desired total vertical field of view of a widely applicable detection aid is approximately 10° , and the horizontal scan rate should preferably be of the order of $10^\circ.s^{-1}$. For the purpose of a developmental device, however, we will specify minimum acceptable parameters :

(d) Total vertical field 5°
(e) Minimum horizontal scan rate $5^\circ.s^{-1}$

Similarly, the size of the IR sensor unit will initially be influenced by the need for experimental flexibility. It is envisaged that an 'engineering prototype' model would be roughly 75 mm diameter x 200 mm long. To allow sufficient versatility in the design of optics, detector assembly, and electronic circuitry, the proposed specification for an experimental sensor unit is :

(f) Diameter 125 mm
(g) Length 250 mm

It has been stated that in all probability a simple visual or audible alarm will be inadequate, for other than short range intrusion detection. Two methods of target indication are proposed :

(h) Target acquisition displays :
(i) lightweight imaging display
(ii) multi-element visual intrusion display

Finally, in order to satisfy military user requirements, the complete detection aid must be self-contained and fully field portable.

We make use of these performance guidelines in subsequent sections of this paper, to formulate a design for a small thermal IR detection aid.

3. PROPOSED THERMAL IR DETECTION AID

3.1 Optical system

In order to meet the specified size and performance requirements, the optical system should have an aperture not exceeding 100 mm, a low f/no., and a focal length - in combination with the IR detector - selected to give an optical resolution of at most 1 mrad. For an optical system in focus at infinity (in practice, for ranges greater than several metres), the relationships which must be satisfied are :

$$\begin{aligned} f &= 100 F \\ &= 100 T \sqrt{t_0} \\ &= 10^3 d \end{aligned}$$

CONFIDENTIAL
UNCLASSIFIED

where

f = focal length (mm)

F = focal ratio (f/no)

T = T/no .

t_o = optics transmission

d = detector size (mm)

For a detector of size $0.1 \times 0.1 \text{ mm}^2$, an optics transmission of 0.5 (integrated over the blackbody spectrum, and allowing for obscuration and a weatherproof IR entrance window), it follows that a 100 mm focal length, $f/1$ optical system has a T/no . of 1.4 and meets the sensor performance specification for angular resolution.

The optical system will be a Cassegrain design, employing aluminium aspheric reflecting surfaces fabricated on the AEL Aspheric Surface Generator. This is inherently a low cost process for the production of complex optical surfaces, and is also amenable to large scale production by established replication techniques.

A preliminary design study has been completed, using proven optical design programmes developed in-house (refs.12,13). The predicted aberrations for a 100 mm focal length system are 0.7 mrad (maximum) over a 75 mrad field of view. This field angle has been set by the current detector array design (Section 3.2). The optical system can be scaled down without degrading optical quality; thus a 50 mm or 75 mm $f/1$ system may be feasible, with a consequent reduction in overall size.

3.2 IR detector array

Research studies at ERL have shown that a single thermal detector cannot satisfy the desired performance specification for a versatile IR detection aid. Thus if we are to avoid the cost and logistic penalties of a cooled photodetector, a multi-element array of thermal detectors must be fabricated. This can be achieved at low cost with the thin film bolometer detector.

A status report on the development of the ERL thin film bolometer (TFB) detector, and an analysis of the performance which may be expected in the proposed IR detection aid, is given in Appendix I. It is predicted that a linear array of TFB detectors can meet the sensor performance specifications given in Section 2.8.

The proposed IR detector array is illustrated in figure 1. It is comprised of a 20 element vertical array of platinum TFB detectors, each of size $0.1 \times .05 \text{ mm}$, and separated by 0.375 mm. The vertical scan is generated by oscillating the field of view along the array axis, giving a total effective array length of 7.5 mm.

For a 100 mm focal length the geometrical instantaneous detector field of view is 1.0 mrad horizontal \times 0.5 mrad vertical. Thus for a perfect optical system, there is a total of 150 vertical resolution elements covering a field of view of 75 mrad (4.3°). In fact, the responsivity over each detector element will not be constant in the horizontal direction (a property of this type of detector), but will vary from zero at the edge to a maximum at the centre. This means that the limiting resolution will be determined by optical aberrations, and the effective detector field of view should be approximately 0.8 mrad.

UNCLASSIFIED
CONFIDENTIAL

UNCLASSIFIED

ERL-0014-TM

In order to keep the size of the array as small as possible, and at the same time retain versatility in sensor design, the individual detector dimensions and overall array length are deliberately smaller than those required to meet the specifications for limiting resolution and vertical field of view. Thus, if the focal length of the optical system is reduced to 75 mm, the total vertical field will be 100 mrad (5.7°); and providing optical aberrations can be kept small, it should be possible to retain a limiting resolution of 1 mrad.

The design of the 20 element detector array has been completed, using the AEL Computer Aided Design (CAD) terminal. This design facility is used in conjunction with a step-photo plotter to produce optical master patterns in a similar manner to hybrid microcircuit fabrication. The actual components of the array: conductors, bonding pads, inorganic dielectric membrane substrate, contacts and detector elements, are prepared by a combination of hybrid microcircuit and vacuum deposition techniques.

The complete array will be fabricated on a 10 mm x 5 mm master substrate and mounted in a hybrid microcircuit package fitted with a zinc selenide window.

3.3 Vertical scan

It is proposed that the vertical scan will be achieved by a nodding action of the secondary mirror in the IR optical system. The amplitude is not large, corresponding to a 7.5 mrad field angle, and it is anticipated that the mirror oscillation will be produced by a small piezoelectric or electromagnetic resonator. A design study is currently underway.

In order to gain maximum coverage with minimum overlap, the vertical scan should be as close as possible to a sawtooth waveform. If the maximum versatility afforded by a combination of optical resolution and detector speed of response is to be realised, then the scan period should be variable over 1.5 to 15 ms, i.e., a frequency range of roughly 70 to 700 Hz. However, in the interests of simplicity, we have standardised on two scan frequencies for the initial design study :

- (a) Basic : 100 Hz for vacuum encapsulated TFB detectors
- (b) Alternate : 200 Hz for LCG encapsulated TFB detectors

3.4 Horizontal scan

The permissible horizontal scan rate will depend on the magnitude of the vertical scan period. The minimum scan rate is approximately $5^\circ \cdot s^{-1}$ for a vacuum encapsulated TFB detector. For faster detectors the scan rate may exceed $10^\circ \cdot s^{-1}$, but with a possible reduction in NET.

Two methods of achieving the horizontal scan are proposed :

- (a) Non-imaging mode of operation - manual panning of sensor head
- (b) Image mode - motor driven platform

Manual scanning is the usual method employed in thermal pointer applications. In this case the sensor unit can be hand-held, or mounted on a monopod, bipod, or rifle.

UNCLASSIFIED

- 12 -
UNCLASSIFIED
CONFIDENTIAL

For the imaging mode, the sensor must be mounted on a steady platform. The actual scanning technique has not been decided, but will be either a motor-driven plane mirror (with the sensor fixed) or rotation of the entire sensor head. Initial studies indicate that a non-electric drive (e.g., a clockwork motor) is feasible, and this is particularly attractive for low-cost, lightweight field equipments.

3.5 Electronics

Since each channel of the detector array must be individually amplified, the design of a multichannel low-noise preamplifier is mandatory. Bolometer preamplifiers of proven performance have been constructed (ref.14). Current effort in this area is directed towards the design of circuits suitable for micro-miniaturisation.

Miniature discrete circuitry is proposed for the experimental IR detection aid. It is intended that, concurrent with circuit development, successful designs will be disseminated to other agencies for conversion to hybrid or monolithic microcircuits.

The next component in the electronic module is the signal multiplexer. Here again experience is available, and a preliminary design study for a TFB array multiplexer has been carried out (ref.15).

The proposed design specification for the experimental detection aid requires that the array preamplifier, multiplexer and ancillary electronics (power supply, filters, offsets, etc.) be common components which, together with the optical head assembly, detector array and vertical scan mechanism, will form a basic sensor unit common to all modes of operation.

Each display or alarm type will require a signal processor module to convert the multiplexed waveform into appropriate signal outputs. In the case of a thermal pointer display and/or a local intrusion alarm, the signal processor is not expected to be unduly complex, and it is anticipated that the processor unit will be provided as an extension to the sensor unit package. The signal processor for an imaging display will be integral within the display package.

The various modes of operation are illustrated schematically in figure 2. It is emphasised that this is a composite diagram, and all of the components shown need not be present in some applications. Thus the horizontal drive is not required for the thermal pointer mode. Furthermore, the multiplexer output is in a form suitable for remote transmission; hence the link between multiplexer and signal processor could well be a single channel ground line or a radio link.

3.6 Output displays

In Section 2.8 it was concluded that the preferred target acquisition displays are :

- (a) a multi-element visual intrusion display, and
- (b) a lightweight imaging display

We also recognise that a simple intrusion alarm may be required in some applications.

At the present time, output displays have been considered only to the extent of identifying feasible technology, in keeping with the specified field requirements. The following proposals are therefore subject to refinement, subsequent to a more detailed design study.

UNCLASSIFIED
CONFIDENTIAL

~~CONFIDENTIAL~~
UNCLASSIFIED

ERL-0014-TM

3.6.1 Thermal pointer display

The thermal pointer display is intended for use in a lightweight, field portable Sentry Detection Aid. It is proposed that the display will comprise a linear array of 20 LED light sources, each source corresponding to an individual detector channel. The array will be fabricated in the form of a 'graticule' for insertion in the focal plane of an optical viewing device. The 'graticule' will be prepared by thin film hybrid microcircuit techniques, with the LEDs in die (chip) form.

We envisage that the display will be used optionally with either :

- (a) an optical telescope, or
- (b) an Individual Weapon Sight (Starlightscope)

The telescope sight, fitted with the LED array, will still be available for normal daylight viewing, and if of 'night glass' design (e.g., 7 x 50 optics), can be used at moonlight levels. For the experimental detection aid, we propose to adapt an existing monocular viewer.

In order to demonstrate the use of the pointer display in a LLL viewing device, we propose to manufacture a modified eyepiece for an available Intensifier Night Sight. This sight is constructed on a modular basis for testing LLL components, and will be assembled for the thermal pointer application as a 25 mm second generation Starlightscope.

In summary, the thermal pointer mode will comprise the sensor unit, optical sight and possibly a small battery pack. This arrangement can be operated in various manners, e.g., as an over-and-under combination, similar to the M16/M203 weapon system.

3.6.2 Imaging display

Three imaging techniques have been considered for the IR detection aid project :

- (a) A LED array, frame scanned by an oscillating mirror
- (b) Signal storage, and replay at normal TV frame rate, using conventional video circuitry
- (c) Real time display, using a CRT with a long persistence phosphor

The design of a very small LED display is conceivable, possibly as a later development of the thermal pointer technology. The short persistence of the LEDs is seen to be a problem for target acquisition, but it is thought that this difficulty could be overcome by the use of a small angular horizontal scan which is dormant in the search mode but activated in the acquisition mode. Initially, however, it is proposed that the imaging display will be of type (b) or (c) above. The relevant technology is established at ERL, and miniature conventional and long persistence CRTs will be available for evaluation.

~~CONFIDENTIAL~~
UNCLASSIFIED

- 14 -
CONFIDENTIAL
UNCLASSIFIED

A particularly attractive proposition during the development phase is to make use of the Night Vision Group Data Acquisition System, as a display unit for sensor input evaluation. This equipment has been constructed for display and analysis of IR imagery obtained during signature measurement.

The size of the experimental imaging display is not expected to exceed 100 mm high x 200 mm long. The unit will be self-contained and fully field portable.

3.6.3 Intrusion alarm

The adaptation of the proposed IR detection aid to intrusion sensor applications is the least demanding of the various operational modes, with regard to signal processing and displays. The alarm can be of the visual, audible or tactile type, with the alarm unit located at the sensor or at some remote control position.

Because of the high inherent resolution and multi-element channel capacity, the performance of the IR detection aid as an intrusion sensor will be vastly superior to existing passive beam break devices.

4. CONCLUSIONS AND RECOMMENDATIONS

It is concluded that thermal detector research and associated IR technology is sufficiently advanced at ERL to commence development of a small IR detection aid. The detection aid described in this proposal is capable of functioning as an intrusion sensor, thermal pointer and lightweight imager. Although primarily intended for Sentry Detection Aid evaluation, the sensor meets the predicted performance requirements for a number of military and maritime surveillance tasks.

The proposed detection aid is small, lightweight and fully field portable. The use of a non-cooled thermal IR detector array avoids the increased cost and complexity of cooled photodetectors. Subsequent prototype development is expected to produce a low cost device; and manufacture entirely within Australia is possible.

It is emphasised that the proposed detection aid is not a new innovation, but is in fact a realistic response to numerous Service requests for recommendations on equipment to meet various tasks. This Technical Memorandum is, in effect, a statement that the technology is now reaching a sufficiently advanced stage to construct the desired equipment.

It is recommended that the construction of a small, lightweight, IR detection aid, incorporating a linear array of uncooled thermal detectors, at ERL, be supported specifically to achieve the following aims :

- (a) To establish the technology of uncooled thermal IR detector arrays and associated optics, signal processing electronics and displays.
- (b) From experience gained in development and field trials, to determine acceptable forms of data displays, assess potential military roles and establish design parameters for Sentry Detection Aid devices.
- (c) By demonstrating an advanced and unique technological capability, to provide a basis for worthwhile information exchange through TTCP.

UNCLASSIFIED
CONFIDENTIAL

CONFIDENTIAL
UNCLASSIFIED

ERL-0014-TM

It is proposed that the project be completed in three distinct developmental phases, as follows :

- Phase I Construction of basic sensor unit assembly
- II Laboratory performance evaluation of sensor assembly
- III Construction of display options
- IV Field trials of complete detection aid

5. ACKNOWLEDGEMENTS

The author wishes to acknowledge the excellent assistance afforded by Micro-engineering Group and Mechanical and Instrumentation Group during the detector research and development programme.

The support, encouragement and guidance given throughout this project by Mr. N.K. Jones is also gratefully acknowledged. Many members of Night Vision Group staff have contributed to the detector research programme. The author is particularly indebted to Mr. J.R. Waller for technical assistance and Mr. M.R. Meharry for many helpful discussions and constructive criticisms.

CONFIDENTIAL
UNCLASSIFIED

- 16 -
 UNCLASSIFIED
 CONFIDENTIAL

REFERENCES

No.	Author	Title
1	Faulkner, D.W.	"Military Night Vision. Characteristics of Human Targets in Thermal Imaging" WRE-TN-OSD 110, February 1970.
2	Biberman, L.M. (Editor)	"A Guide for the Preparation of Specifications for Real-Time Thermal Imaging Systems" IDA Paper P-676, January 1971.
3	-	"Passive Linear Intrusion Sensor System" AHQ Exploratory Development Task 1090.3, 21 December, 1972"
4	-	"Sentry's Detection Aid" Army Staff Requirement No. 24.4, 4th June, 1976.
5	Pybus, A.W. (Editor)	"Military Night Vision. Thermal Imaging For Army Applications, Including An Account of Field Experiments at W.R.E. In June, 1965" WRE-Report-CPD 20, March 1966.
6	Pybus, A.W.	"Army Surveillance Investigation. Department of Supply Task in Support of AHQ Research Request No. 1039/68 (Exercise Darklight)" WRE-Report-OSD 20, September 1970.
7	Jones, N.K.	"Assessment of the Feasibility of Detecting Low Flying Aircraft With Uncooled Thermal Imagers" WRE-TM-1589 (AP), April 1976.
8	Jones, N.K.	"Maritime Surveillance at Night" WRE-TM-1180 (AP), 1975.
9	Anderson, N.J. et al	"Analysis of Exercise Warm Waters" R.A.N.R.L. Report 2/75, July 1975.
10	Trials Directorate, Services Laboratories and Trials Division, Department of Defence	"Sea Trials of Night Vision Equipment" Defence Trials Report 392, Annex B, 1978.

UNCLASSIFIED
 CONFIDENTIAL

CONFIDENTIAL
UNCLASSIFIED

ERL-0014-TM

No.	Author	Title
11	Liddiard, K.C.	"Feasibility Study on Methods of Improving the Night Effectiveness of RAN Submarine Periscopes" WRE-TN-OSD 104, March 1969.
12	McQuistan, G.W.	"Optical Design of Aspheric Mirrors" WRE-TR-1742 (AP), March 1977.
13	McQuistan, G.W.	"Optical Design for an Array Scanning Bolometer Radiometer" WRE-TM-1964 (A), April 1978.
14	Rice, B.W.	"A Radiation Thermometer Developed For The Atomic Energy Commission" WRE-TN-849 (AP), January 1973.
15	Heilbronn, D.J.	"A Preliminary Investigation Into Multiplexing Low-Level Signals From Bolometer Arrays" ERL-TM (in publication)
16	Liddiard, K.C.	"Infrared Detector Research. Metal Film Bolometer Detectors" ERL-Report (in preparation).
17	Liddiard, K.C.	"Infrared Detector Research. Metal Film Infrared Absorbers" WRE-TN-1165 and 1166, May 1975.
18	Putley, E.H.	"Topics in Applied Physics. Vol. 19 : Optical and Infrared Detectors, Ch. 3" (Berlin, Springer, 1977)

UNCLASSIFIED

APPENDIX I

PERFORMANCE OF ERL THERMAL INFRARED DETECTORS

I.1 Metal film bolometer detectors

Research on thermal IR detectors at ERL is currently directed towards the preparation of high performance metal film bolometer detectors (ref.16). This project follows earlier work on metal film infrared absorbers (ref.17), and represents the second stage of a continuing programme of research on elemental thermal detectors.

Thin film bolometer (TFB) detectors are conceptually simple and inexpensive to manufacture. However, the attainment of performance comparable or superior to the best commercially available thermal detectors is dependent on a fundamental knowledge of the thermophysical, optical, electrical, mechanical and structural properties of thin metal films; and on the relationship between these properties and the vacuum deposition process. ERL metal film bolometers have been developed approaching the theoretical optimum for this type of sensor material. They can be fabricated with an element size ranging from several millimetres to less than 0.05 mm, and are readily adaptable to large arrays using established microcircuit techniques.

A current TFB detector consists of a platinum film less than 10 nm thick, vacuum deposited onto a 20 nm thick inorganic dielectric membrane substrate. The detectors are mounted on transistor headers and are operated in vacuo or in an atmosphere of argon or low conductivity gas (LCG). Emphasis is now being placed on the development of arrays of detectors and long-life detector encapsulation techniques for field applications.

The performance of platinum TFB detectors is given in Table 1.

TABLE 1. PERFORMANCE OF ERL METAL FILM BOLOMETER DETECTORS

Detector Encapsulation	Responsivity ($V.W^{-1}$)	Time Constant (ms)	N.E.P. ₁ ($W.Hz^{-\frac{1}{2}}$)	$D^*_{\frac{1}{2}}$ ($cm.Hz^{\frac{1}{2}}.W^{-1}$)
Vacuum	50	1.0	5×10^{-11}	2×10^8
LCG	25	0.5	1×10^{-10}	1×10^8
Argon, 760 torr	5	0.25	5×10^{-10}	2×10^7
Detector size : 0.1 mm x 0.1 mm; N.E.P. : noise equivalent power LCG : low conductivity gas; Test Frequency : 20 Hz				

UNCLASSIFIED
CONFIDENTIAL

ERL-0014-TM

Comparison of this data with available commercial detectors shows that the D^* of the LCG encapsulated detector is comparable with that of a thermistor flake bolometer of similar size. The speed of response of the thermistor bolometer is, however, somewhat slower, being roughly the same as the more sensitive vacuum encapsulated detector. This is a pleasing result, because the thermistor flake bolometer is the only readily available thermal detector of size $0.1 \times 0.1 \text{ mm}^2$.

The most recent information on the pyroelectric (PE) detector (see, e.g., reference 18), indicates that detectors of size 0.5 to 1.5 mm square in research samples have an N.E.P. comparable to the vacuum encapsulated TFB and a detectivity of at least $10^9 \text{ cm.Hz}^2.\text{W}^{-1}$. However, a survey of the data of several manufacturers suggests that the D^* of the best PE detectors is comparable to that of the best TFB samples. In any case, some care must be taken in making comparisons with the PE detector. Firstly, the frequency response falls off more rapidly at low frequencies (less than 500 Hz) than the TFB, but extends to higher frequencies; so that the PE detector is well suited to high power, short pulse applications, e.g., laser detection. Secondly, the size of the PE detector is large (the smallest known to the author is $0.25 \times 0.25 \text{ mm}^2$ in experimental samples). This means, in effect, that for a detection device of given optical aperture and specified angular resolution, the D^* of a TFB can be less than that of a PE detector by the ratio the area of the two detectors, in order to achieve roughly the same limiting range performance.

Finally, the PE detector in its present form is not readily adaptable to large array fabrication. The PE vidicon camera tube has, however, reached an advanced stage of development, but is more likely to compete with systems such as the AGA Thermovision than with small, low cost, detection aids.

I.2 Detector research programme

Whilst the performance of ERL metal film bolometer detectors is comparable or superior to most commercial thermal detectors, it is not possible to achieve thermal-noise-limited operation. The ultimate performance of a thermal infrared detector is determined by thermal fluctuation noise, and this limit cannot be attained with free-electron conducting materials because of the low temperature coefficient of resistance. The future research programme on thin film bolometer detectors at ERL will emphasise the replacement of the metal film with a thin film semiconductor material having a much higher temperature coefficient of resistance. Initial experiments have shown promise in this direction.

It can be shown that a moderate increase in temperature coefficient of resistance will lead to an improvement of a factor of 5 in D^* . If this prediction is achieved in practice, the thin film bolometer detector will become the most sensitive and versatile of all known room temperature thermal detectors.

We show in this Appendix that current metal TFB detectors are capable of meeting the performance specifications for an experimental IR detection aid. The relevance of an on-going detector research programme is that a further advance in detector technology may become available for prototype development. This work should thus be seen as part of a natural progression in technological improvement, carried out in parallel with, but not essential to, development of an experimental sensor device.

UNCLASSIFIED
CONFIDENTIAL

CONFIDENTIAL
UNCLASSIFIED

I.3 Detector performance predictions

Let us now consider the ability of ERL metal film bolometer detectors to meet the sensor performance specifications derived in Section 2.8.

The NET of an IR detection system is related to the noise equivalent power of the infrared detector, for a target background at temperature 300 K, by

$$NET = 6.53 \times 10^5 \left(P_n \sqrt{\Delta f} \right) \frac{T^2}{A} \quad (1)$$

where P_n = noise equivalent power for unit bandwidth ($W.Hz^{-1/2}$)

Δf = system noise bandwidth (Hz)

T = T number of the sensor optical system

A = detector area (mm^2)

Equation (1) applies for a blackbody target at zero range; and by definition, the target must fill the detector field of view. Atmospheric transmission loss is taken into account when determining the required sensor MDT, and hence NET.

For a simple radiometer the sampling time can be of the order of one second, and hence the bandwidth is small. However, for a scanning system, the bandwidth needs to be sufficiently large to accommodate all the information available from the detector during its dwell time across the target. The bandwidth of the sensor should be at least that of the inherent detector noise bandwidth, and for white noise this is :

$$\Delta f = 1/(4\tau) \quad (2)$$

where τ is the detector time constant. This relationship will apply for a metal film bolometer, used in conjunction with a high-pass filter (to remove $1/f$ noise) and a suitable low-noise preamplifier. For a vacuum encapsulated detector the minimum bandwidth is thus 250 Hz.

The speed of response of the IR detector also determines the maximum permissible scan rate which can be achieved without loss in sensitivity. The detector dwell time is usually taken to be :

$$t_d = 2\tau \quad (3)$$

Hence equation (2) can be expressed in the alternative form

$$\Delta f = 1/(2t_d) \quad (4)$$

Equation (4) can be interpreted in a more general way as a relationship between observation time and system bandwidth. Thus if the dwell time is increased, we can accept a trade between scan rate and NET.

CONFIDENTIAL
UNCLASSIFIED

UNCLASSIFIED

ERL-0014-TM

From scanning theory it is readily shown that for a 100% duty cycle (i.e., no dead time in the scan), the horizontal scan rate is given by :

$$\dot{\theta}_h = \frac{N}{t_d} \left(\frac{\alpha_h \alpha_v}{\theta_v} \right) \text{ rad.s}^{-1} \quad (5)$$

where α_h = horizontal instantaneous detector field of view (rad)
 α_v = vertical instantaneous detector field of view (rad)
 θ_v = total vertical field of view (rad)
 N = total number of detectors used in the scan

It is now possible to compute NET for the TFB detectors given in Table 1. In accordance with the sensor performance specification (Section 2.8), a resolution of 1 mrad is achieved with an optical system of focal length 100 mm. The optical aperture will be of similar dimensions, in agreement with the specification for overall size, and the T number will be of the order of 1.5. If we assume a total vertical field of 100 mrad (5.7°) and a horizontal scan rate of 100 mrad.s^{-1} , we arrive at the results given in Table 2.

TABLE 2. IR SENSOR PERFORMANCE

Detector Encapsulation	Δf (Hz)	t_d (ms)	N	NET (K)
Vacuum	250	2.0	20	0.12
LCG	250	2.0	20	0.23
	500	1.0	10	0.33
Argon, 760 torr	250	2.0	20	1.2
	500	1.0	10	1.6
	1000	0.5	5	2.3
$\alpha_h = \alpha_v = 1 \text{ mrad}$		$\theta_h = 100 \text{ mrad.s}^{-1}$		
$T = 1.5$		$\theta_v = 100 \text{ mrad}$		

UNCLASSIFIED

CONFIDENTIAL
UNCLASSIFIED

These results indicate that a 20 element array of vacuum or LCG encapsulated TFB detectors should be capable of achieving the desired NET, vertical field of view, and horizontal scan rate. This is the method proposed in Section 3 for an experimental thermal IR detection aid.

It may be noted that if the size of the detector was increased to $0.5 \times 0.5 \text{ mm}^2$, and the sensitivity and speed of response remained the same, the computed NET would be smaller by a factor of 25. In this case a 50 cm target previously resolved at 500 m would now be resolved at 100 m, and beyond this range the signal power would fall as $1/R^2$. If the focal length was increased to 500 mm to achieve 1 mrad resolution, the T number would increase 25 times with the same NET as before. This is just the argument pointed out in Section I.1 of Appendix I with regard to the PE detector.

CONFIDENTIAL
UNCLASSIFIED

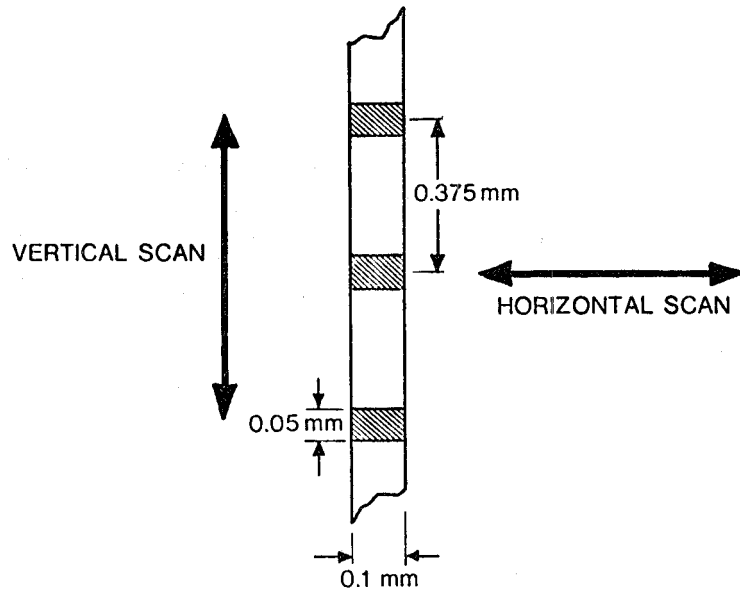

DETECTOR SIZE ——— 0.05 mm x 0.1 mm
NUMBER OF DETECTORS — 20
LENGTH OF ARRAY ——— 7.5 mm
EFFECTIVE NUMBER OF
VERTICAL RESOLUTION ELEMENTS — 150

1. Thermal IR detector array

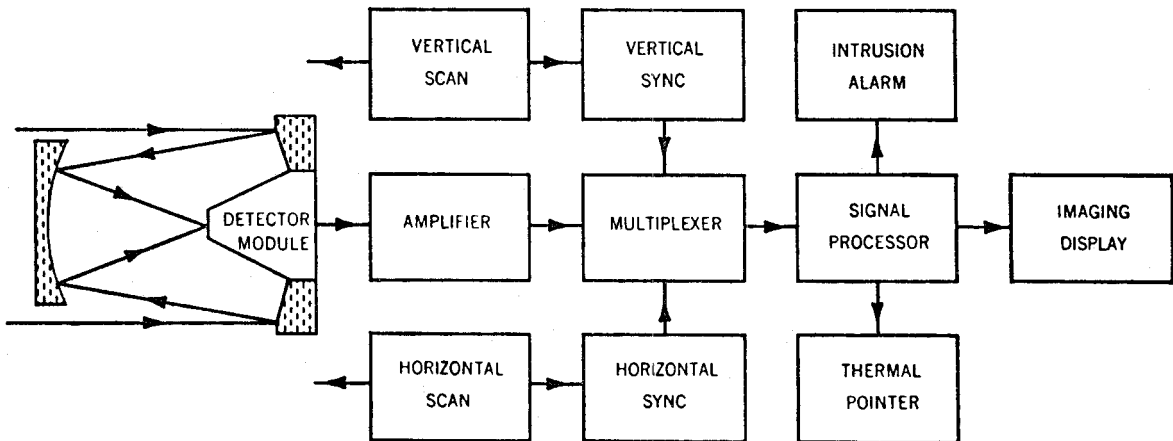

2. Thermal IR detection aid schematic

DOCUMENT CONTROL DATA SHEET

Security classification of this page

UNCLASSIFIED

1 DOCUMENT NUMBERS	
AR Number:	AR-001-195
Report Number:	ERL-0014-TM
Other Numbers:	

2 SECURITY CLASSIFICATION	
a. Complete Document:	UNCLASSIFIED
b. Title in Isolation:	UNCLASSIFIED
c. Summary in Isolation:	UNCLASSIFIED

3 TITLE	DEVELOPMENT OF A SMALL HIGH PERFORMANCE THERMAL INFRARED DETECTION AID
---------	--

4 PERSONAL AUTHOR(S):
K.C. Liddiard

5 DOCUMENT DATE:
May 1978

6	6.1 TOTAL NUMBER OF PAGES	32
	6.2 NUMBER OF REFERENCES:	18

7	7.1 CORPORATE AUTHOR(S):
Electronics Research Laboratory	
	7.2 DOCUMENT SERIES AND NUMBER
Electronics Research Laboratory 0014-TM	

8 REFERENCE NUMBERS	
a. Task:	DST 58/02
b. Sponsoring Agency:	

9 COST CODE:
308770

10 IMPRINT (Publishing organisation)
Defence Research Centre Salisbury

11 COMPUTER PROGRAM(S) (Title(s) and language(s))

12 RELEASE LIMITATIONS (of the document):									
UNCLASSIFIED									
12.0	OVERSEAS	NO	1	P.R.	A	B	C	D	E

Security classification of this page:

UNCLASSIFIED

13 ANNOUNCEMENT LIMITATIONS (of the information on these pages):

No limitation.

14 DESCRIPTORS:

a. EJC Thesaurus
Terms

Infrared detection
Infrared radiation
Infrared thermal
detectors
Infrared equipment
Infrared surveillance

b. Non-Thesaurus
Terms

Thermal imaging
Intrusion sensors

15 COSATI CODES:

1705
1504

16 LIBRARY LOCATION CODES (for libraries listed in the distribution):

SW SR SD AACA

17 SUMMARY OR ABSTRACT:

(if this is security classified, the announcement of this report will be similarly classified)

This Memorandum describes the proposed development of a small, lightweight thermal IR detection aid, capable of operation as an IR intrusion sensor, a thermal pointer and a man-portable thermal imager.