

## REPORT DOCUMENTATION PAGE

The public reporting burden for this collection of information is estimated to average 1 hour per response, including the time for reviewing instructions, searching existing data sources, gathering and maintaining the data needed, and completing and reviewing the collection of information. Send comments regarding this burden estimate or any other aspect of this collection of information, including suggestions for reducing this burden, to Department of Defense, Washington Headquarters Services, Directorate for Information Operations and Reports (0704-0188), 1215 Jefferson Davis Highway, Suite 1204, Arlington, VA 22202-4302. Respondents should be aware that notwithstanding any other provision of law, no person shall be subject to any penalty for failing to comply with a collection of information if it does not display a currently valid OMB control number.  
**PLEASE DO NOT RETURN YOUR FORM TO THE ABOVE ADDRESS.**

<b>1. REPORT DATE (DD-MM-YYYY)</b> 03-11-2008		<b>2. REPORT TYPE</b> Final		<b>3. DATES COVERED (From - To)</b>	
<b>4. TITLE AND SUBTITLE</b> Test Operations Procedure (TOP) 1-2-619 Nuclear Thermal and Blast Hardness Validation Test			<b>5a. CONTRACT NUMBER</b>		
			<b>5b. GRANT NUMBER</b>		
			<b>5c. PROGRAM ELEMENT NUMBER</b>		
<b>6. AUTHORS</b>			<b>5d. PROJECT NUMBER</b>		
			<b>5e. TASK NUMBER</b>		
			<b>5f. WORK UNIT NUMBER</b>		
<b>7. PERFORMING ORGANIZATION NAME(S) AND ADDRESS(ES)</b> Survivability, Vulnerability, & Assessment Directorate (TEDT-WS-SV-N) US Army White Sands Test Center White Sands Missile Range, NM 88002-5158				<b>8. PERFORMING ORGANIZATION REPORT NUMBER</b> TOP 1-2-619	
<b>9. SPONSORING/MONITORING AGENCY NAME(S) AND ADDRESS(ES)</b> Test Business Management Division (TEDT-TMB) US Army Developmental Test Command 314 Longs Corner Road Aberdeen Proving Ground, MD 21005-5055				<b>10. SPONSOR/MONITOR'S ACRONYM(S)</b>	
				<b>11. SPONSOR/MONITOR'S REPORT NUMBER(S)</b> Same as item 8	
<b>12. DISTRIBUTION/AVAILABILITY STATEMENT</b> Approved for public release; distribution unlimited.					
<b>13. SUPPLEMENTARY NOTES</b> Defense Technical Information Center (DTIC), AD No.: This TOP supersedes TOP 1-2-619, 31 July 1996.					
<b>14. ABSTRACT</b>  This TOP describes the techniques, procedures, and general outline required to assess the effects of the nuclear thermal and airblast environments on Army materiel. Test/Analysis preparation, execution, and documentation are covered in this TOP.					
<b>15. SUBJECT TERMS</b>  Nuclear Thermal                      Nuclear Airblast                      Finite Element Analysis                      Synergistic Effects					
<b>16. SECURITY CLASSIFICATION OF:</b>			<b>17. LIMITATION OF ABSTRACT</b>  SAR	<b>18. NUMBER OF PAGES</b> 38	<b>19a. NAME OF RESPONSIBLE PERSON</b>
<b>a. REPORT</b> Unclassified	<b>b. ABSTRACT</b> Unclassified	<b>c. THIS PAGE</b> Unclassified			<b>19b. TELEPHONE NUMBER (include area code)</b>



US ARMY DEVELOPMENTAL TEST COMMAND  
TEST OPERATIONS PROCEDURE

\*Test Operations Procedure (TOP) 1-2-619  
DTIC AD No.:

3 November 2008

NUCLEAR THERMAL AND BLAST HARDNESS VALIDATION TEST

		<u>Page</u>
Paragraph	1. SCOPE.....	1
	2. FACILITIES AND INSTRUMENTATION.....	2
	2.1 Facilities .....	2
	2.2 Instrumentation.....	3
	3. REQUIRED TEST CONDITIONS.....	4
	3.1 Pre-Test Investigation.....	4
	3.2 Instrumentation Installation.....	6
	4. TEST PROCEDURES .....	7
	4.1 Nuclear Thermal.....	7
	4.2 Nuclear Blast .....	9
	4.3 Synergistic Effects.....	10
	5. DATA REQUIRED.....	10
	6. PRESENTATION OF DATA .....	12
Appendix	A. GENERAL GUIDELINES AND CALCULATIONS FOR NUCLEAR THERMAL.....	A-1
	B. GENERAL GUIDELINES AND CALCULATIONS FOR NUCLEAR BLAST .....	B-1
	C. GENERAL GUIDELINES FOR FINITE ELEMENT ANALYSIS (FEA) FOR NUCLEAR BLAST, THERMAL, AND SYNERGISTIC EFFECTS .....	C-1
	D. NUCLEAR THERMAL ENVIRONMENT .....	D-1
	E. NUCLEAR BLAST ENVIRONMENT .....	E-1
	F. ACRONYMS .....	F-1
	G. REFERENCES.....	G-1

\*This TOP supersedes TOP 1-2-619, dated 31 July 1996

---

Approved for public release, distribution unlimited.

1. SCOPE.

This Test Operations Procedure (TOP) outlines the procedures and facilities necessary to perform a nuclear thermal and blast hardness validation test/analysis. The hardness validation principles covered in this TOP may be applied to the hardness assessment of major weapon systems, subsystems, and line replaceable units. Nuclear blast facilities still exist and are capable of validating the system against blast effects. However, high fidelity nuclear thermal facilities and thermal-blast synergistic facilities are non-existent; therefore, numerical and finite element methods must be utilized to provide the total system validation.

2. FACILITIES AND INSTRUMENTATION.

2.1 Facilities.

2.1.1 The selection of the simulation facility required for performing a thermal and/or blast test is driven by the test item's material characteristics and nuclear survivability criteria. The number of thermal and blast test facilities has greatly reduced over the past decade to one of each within the DOD. At present there is no thermal facility available for system level testing; nor are there any combined thermal and blast facilities available for synergistic effects testing. This reduction in facilities (especially thermal) has placed the burden for system evaluation to selective component/coupon level testing and the analysis/modeling arena.

2.1.2 The following list outlines the types of facility characteristics that will be necessary to perform nuclear thermal and blast testing.

<u>Facility</u>	<u>Requirement</u>
Thermal Radiation Facility	Capability to simulate a nuclear thermal pulse, over small test areas, at reduced Flux, for model verification.
High Explosive Detonation Facility	Capability to simulate ideal blast for large test items, the peak static overpressure, low level dynamic pressure, and ground shock environment produced by a nuclear weapon detonation.
Shock Tube Facility	Capability to simulate peak static overpressure of small yields for small test items that do not translate or require ground shock.
Large Blast Thermal Simulator (LB/TS)	Capability to realistically simulate, for large test items, the peak static overpressure, dynamic pressure, and associated duration of weapon yields under 300 kT; Capability to realistically simulate non-ideal blast. *Thermal environment no longer available; therefore, thermal/blast synergistic environment no longer available.*
Thermal Analysis Facility	Computation facility capable of thermal modeling a nuclear burst.

2.1.3 It must be noted that the environment provided by a simulation facility will typically not meet all of the criteria parameters specified by the test item's Nuclear Survivability Criteria document. Therefore, effort must be taken to select a facility that will provide the best approximation to the criterion parameter posing the most significant threat to the test item, and significant analysis must be performed to compensate for the shortcomings of the test environment and their impact on test results.

## 2.2 Instrumentation.

2.2.1 The following list outlines several of the major environmental parameter measurement requirements, type of measuring device, and the recommended accuracy. Some test facilities may require the user to provide the instrumentation and perform the installation while others may provide this service for an additional fee.

	<u>Measurement</u>
<u>Device for Measuring</u> Temperature (thermometer, thermocouple)	<u>Measurement Accuracy</u> $\pm 5\text{ }^{\circ}\text{C}$
Flux (maximum irradiance) (calorimeter )	$1 \pm 10\% \text{ cal/cm}^2\text{-sec}$
Fluence (total thermal energy) (integral of calorimeter data)	$1 \pm 10\% \text{ cal/cm}^2$
Displacement (horizontal, vertical, roll) (displacement gage, measuring tape)	$\pm 1 \text{ cm}$
Acceleration (accelerometer, piezo-resistive, piezoelectric etc.)	$\pm 10\% \text{ g}$
Strain (foil strain gage, resistance)	$\pm 10\% \text{ }\mu\text{m}/\mu\text{m}$
Overpressure (pressure gage, piezo-resistive, electric, etc)	$\pm 10\% \text{ kPa}$
Time (transient data recorder)	$1 \text{ msec } \pm 10\% \text{ sec}$

2.2.2 The facility data instrumentation must be able to record and archive the induced responses and have enough data channels to accommodate the test item and environmental data requirements. The data recording rate (samples/second) must be capable of recording the test item response. For digital recording, the sample rate must be at least eight times the expected data frequency. The data output can be generated in several formats and at a minimum; a conversion process to ASCII must be available to ensure compatibility with data reduction software. Typically, the minimum instrumentation requirements for blast and thermal data have frequency content up to approximately 2 kHz and duration of approximately 2 seconds. Therefore, the data recording equipment requires a minimum data acquisition rate of 16 kHz (62.5 microseconds per data point) and a two second recording window.

2.2.3 Still and motion photography or video support must be available to document the pre-test setup, the test item's real time response, and the test item's post-test configuration. High speed video cameras are used to monitor a test item's response during the test; cameras can be selected with frame rates from 1000 to 10's of thousands with a trade off in pixel density. Typically 3000 frames per second will be adequate.

### 3. REQUIRED TEST CONDITIONS.

#### 3.1 Pre-Test Investigation.

3.1.1 System specific information must be gathered to determine normal operational mode, configuration, and setup. The test item must be investigated to identify the mission critical components which are most likely to be susceptible to the thermal, blast and combined thermal/blast environments and if any system waivers exist. The possible test item configurations must be investigated to determine which configuration poses the most probable and the worst case exposure scenario. The test must be designed using realistic scenarios. The test item functional requirements must be identified and a functional checkout procedure and failure criteria based on mission performance established. Typically, the largest surface areas with all external items deployed will provide the worst case test configuration.

3.1.2 All hazardous materials contained in the test item must be identified, and a plan developed to include removal or protection of the materials and appropriate recovery and clean up procedures in case of a spillage or dispersion during test. Material Safety Data Sheets (MSDS) for all the applicable test item materials/equipment must be available online or at the test site.

3.1.3 Analysis should include modeling the test item in the most probable and worst case configuration, using numerical or finite element methods to predict the item's response to the thermal and blast environments. With the lack of thermal facilities this becomes the basis for the thermal environment and any synergistic blast/thermal effects. Typically, the information required to perform an analysis are: a system Computer Aided Drafting (CAD) model, and detailed material information such as presented in Table 1.

Table 1. Material Information

	Melting Point	Density	Specific Heat	Thermal Conductivity	Thermal Resistance	Yield Strength	Yield Strength Ultimate	Shear	Modulus of Elasticity
	°C	kg/m <sup>3</sup>	Cal/kg°C	Cal/sm°C	sm°C/cal	MPa	MPa	MPa	MPa
AIR	NA	1.2	239.8	6.12E-03	1.63E+02	NA	NA	NA	NA
Kevlar	NA	1440	81.2	9.55E-03	1.05E+02	-----	3000	----	112000
Steel	1330	7850	103.659	14.447	6.92E-02	379	455	80000	200000
Ceralloy (ceramic)	>1371	3210	143.33	26.26	3.81E-02	1400	303000	----	448000

3.1.4 Test data requirements, instrumentation type, and placement should be defined to accurately monitor the response of the test item (be it full system or coupons) and to enable analysis of the test results. Predictions (based on experience or calculation) of the expected induced signals must be made to establish the instrumentation setup parameters. These data are used to make comparisons with: the test environment criterion, the test item normal operating vibration specifications, and for verification of analytical methods. Typically, for the blast environment the test item requires at a minimum pressure gages to be installed in the different system sections ( i.e. engine, turret, and crew areas) and tri-axial accelerometers to be placed on system structures (i.e. the main system frame, rack supported equipment, shock mounted equipment, and solidly attached external equipment). These data can be compared to personnel incapacitation, injury, and safety requirements and are used to make comparisons with the test item vibration specifications and drop test data. Typically, for the thermal environment the test item requires thermocouples for measuring the test item free field external, internal cavity, and internal surface temperatures. These data are used in conjunction with analytical methods to extrapolate the full criterion response.

3.1.5 Analysis forms the basis of the evaluation for thermal, blast (blast tests can be used for the system blast response), and synergistic effects on the test item which would result from exposure to the realistic, combined nuclear thermal and blast environments. This analysis is required since no facility exists which can provide the correct thermal profile for other than man exposed or airborne items, and none exist which provide the thermal and blast synergistically. Monte Carlo methods may be used to confirm-design safety margins and increase evaluation confidence which is otherwise low due to limited simulator capabilities and a small number of test samples. Typically, an analysis should be performed at 1.3X the most significant environment parameter for that item, usually incident side overpressure (a combination of the peak static and dynamic overpressures), on the most probable worst case configuration.

3.1.6 The testing/analysis may be reduced if applicable test results are available from previous testing on similar test items, components/materials. However, care must be exercise when using similarity evaluations.

3.1.7 Completely functional prototypes or production versions of a test item may not be required for testing if the configuration differences are transparent to the test environment. For example, mass simulators of subsystems may be used to perform blast testing and subassemblies, components, and coupons are used to conduct thermal testing. Test coupons must be representative of the exposed area on the test item.

3.1.8 The selected simulation facility's test volume must be able to accommodate the test item, or the test item may be configured (maintaining a representative configuration) to fit in the facility's test volume. Test item cross sectional area blockage should not exceed 20 percent of the available cross-section if a shock tube is used.

3.1.9 Nuclear thermal and blast tests may be considered potentially destructive tests and usually are placed at the end of an item's test cycle.

### 3.2 Instrumentation Installation.

3.2.1 Blast: The instruments should be positioned at locations on the test item based on the pre-test analysis. Data transmission are normally through twisted pair or coaxial cables, and input into an adjustable gain high impedance signal conditioner/instrumentation amplifier whose output is then fed to the transient data recorder. The pre-test predictions should provide the gain settings for the amplifiers which are selected to allow for considerable dynamic range. The blast instrumentation cables must be capable of surviving the test environment. Cables must be installed to maximize protection from the environment, installed neatly, and tied down at multiple points to reduce cable slap (movement) which can generate spurious electrical signals. Data instrumentation for the blast test (see paragraph 2.2.1) should include the following:

a. Pressure: Environment pressure transducers to measure the free field overpressure and free field dynamic pressure; these are usually provided, installed, and maintained by the test facility. Test item pressure transducers should be installed on the largest incident surface and in each major internal cavity to measure the total external force applied (i.e. static and dynamic combined) and the pressures induced internally where personnel and equipment are located, respectively.

b. Acceleration: Accelerometers are used to measure the accelerative forces applied to the test item and the selected internal equipment. Accelerometers in general measure the motion of the overall test item response and that of internal and external equipment. Pressure and accelerometer gages are affixed to the test item using two methods; 1) attached using machined taps and screws and 2) glued in place with RTV or a similar adhesive.

c. Strain: Strain gages are installed to measure the strain applied to support structures and their use is generally limited to external equipment. Strain gages are applied using the manufacturer's application procedures.

d. Displacement: Displacement devices are used to measure test item deformation and are generally used on compartment walls where impact to the internal equipment is problematic. Displacement gages are usually attached to the internal equipment, which is impact sensitive using machined taps and screws or adhesive.

e. Video: High speed motion video is used to visually record the real time response of the test item. The high speed cameras are generally facility provided and include the blast hardened enclosure.

3.2.2 Data instrumentation for the thermal test should include thermocouples to measure the free field, test item (usually coupons for large items), test item internal cavity temperatures, and calorimeters to measure the thermal flux and fluence of the test environment. These transducers and calorimeters should be positioned at locations on the test item based on the pre-test analysis. Avoid shadowing of gages unless deliberately placed to measure impacts of shadowing. The free field waveform generated by the calorimeters will be used to evaluate the simulated thermal radiation environment against the thermal criteria specified for the test item and for model verification. Calorimeters are in general provided and installed by the test facility. Test item thermocouples are positioned in the same geometric positions used during development of the analytical model, center of the measurement volume and mounted to the surfaces with heat conductive paste and or tape. Cabling must be routed to preclude exposure to the thermal environment.

#### 4. TEST PROCEDURES.

##### 4.1 Nuclear Thermal.

###### 4.1.1 Test Setup.

a. Develop a thermal model of the test item (both system and coupon level) utilizing basic numerical method and preferably finite element methods. Run simulations to predict the test item response while driven by the criterion and facility thermal profiles.

b. Baseline the test item by conducting a visual inspection of the surfaces to be exposed to the thermal pulse and performing any applicable functional checkouts. Photographs of the test item should be taken to document the item's pre-test condition. Document the type and condition of any thermal hardening measures used in the test item's design such as ablative paint or reflective coatings/covers. In the event that non-production material is used in or as the test item, document the differences between that material and the expected production items. An analysis will be required to determine effects on the production items. . The following test item description data should be compiled: (1) Serial number, (2) Serial numbers for subcomponents (if applicable), (3) Dimensions, (4) Material Composition, (5) MSDS(s) (if applicable), (6) Mechanical drawings, (7) Operating status and recovery procedures.

c. At the proper test location, place and secure the test item on the test bed in the configuration established by the pre-test investigation (paragraph 3.1). Ensure the test item is placed such that the test can provide the required data.

d. Instrument the test item according to the data instrumentation requirements established during the required test conditions (paragraph 3.1.4). Confirm the placement of the free field instrumentation, and verify that the data acquisition system is operational. All instrumentation (thermocouples and calorimeters) and data acquisition system calibration data must be documented. Document the test item placement and instrumentation locations by test layout drawings and/or photographs of the test setup. To the extent possible, baseline the test item again while in the test setup mode.

e. Place the test item in the proper operational mode, if applicable, and perform final checkouts.

f. Perform the thermal test and record data and video of the test item response.

g. Once it is safe to approach the test item, without moving or handling the test item an overall visual inspection is performed. The following should be inspected, documented, and photographed:

(1) The condition of the thermal hardening measures. Is ablative material or paint charred? Is ablative material or paint completely burned off? Is reflective coating/cover damaged?

(2) The condition of the test item's main structure. Is the structure charred, flaming, or burned? Is the structure rigid, warped, or pliable? Is material/soot deposited on the test item? Did melting and/or frosting occur? Did cracking occur? Did color changes occur? Did the material bubble?

(3) Was the target area exposed as expected? Is there evidence of non-uniformity?

(4) The test item's functionality. If applicable, is the test item operational? If not, is it repairable? Does the test item meet the failure criteria established in paragraph 3.1.1?

(5) Instrumentation condition. Are all gages mounted and intact? Are data cables properly attached and undamaged?

h. The results of all the post-test checkouts should be recorded using Test Incident Reports (TIRs); detailed procedures on TIRs are contained in DTC PAM 73-1<sup>1\*\*</sup>.

i. Compare the thermal radiation environment measurements with the expected environment; the thermal fluence expressed in Joule per meter squared ( $J/m^2$ ) or calories per square centimeter ( $cal/cm^2$ ), flux expressed in joules per square meter per second ( $J/m^2\text{-sec}$ ) or calories per square centimeter per second ( $cal/cm^2\text{-sec}$ ), time to maximum irradiance expressed in seconds, and pulsewidth full width/half maximum (FWHM) expressed in seconds

---

\*\* Superscript numbers correspond to those in Appendix G, References.

j. Compare the test results with the model predictions, factors of 2 are considered acceptable and adjust model accordingly.

k. All test data and results, and pertinent information is archived into the test item Life-Cycle program database for future evaluation and assurance management.

## 4.2 Nuclear Blast.

### 4.2.1 Test Setup.

a. Develop a blast model of the test item (system level) utilizing basic numerical methods and preferably finite element methods. Execute simulations to predict the test item response while driven by the criterion and facility blast profiles. NOTE: the LB/TS is available and can meet most criterion requirements; therefore, modeling may not be necessary if blast effects are the main concern or if the test item materials are not expected to change characteristics dramatically with temperature (this is usually true for metals with thickness greater than 1.2 cm or which are protected by external materials such as Kevlar or Ceramics).

b. Baseline the test item by conducting a visual inspection of the test item to be exposed to the blast environment and performing any applicable functional checkouts. Photographs of the test item should be taken to document the item's pre-test condition. In the event that non-production material is used in or as the test item, document the differences between that material and the expected production items for later analysis.

c. At the proper test location, place and secure (if required) the test item on the test bed in the configuration established by the pre-test investigation (paragraph 3.1). Ensure the test item is placed such that the test can provide the required data. Verify that precautionary measures for any hazardous materials as determined in paragraph 3.2.1 are in place.

d. Position visual markers/indicators on the test item. Tether the test item if required. Instrument the test item according to the data instrumentation requirements established during the required test conditions (paragraph 3.1.4). Confirm the placement of the free field instrumentation, and verify that the data acquisition system is operational. All instrumentation (pressure, accelerometers, displacement, and strain) and data acquisition system calibration data must be documented. Document the test item placement and instrumentation locations by test layout drawings and/or photographs of the test setup. Ensure the high speed motion video cameras are properly aimed and ready, have proper lighting and exposure settings. To the extent possible, baseline the test item again while in the test setup mode.

e. Place the test item in the proper operational mode, if applicable, and perform final checkouts.

f. Perform the blast test and record data and video of the test item response.

g. Once it is safe to approach the test item, without moving or handling the test item an overall visual inspection is performed. The following should be inspected, documented, and photographed:

(1) The condition of the test item's main structure. Was the test item translated, rotated, or overturned? Is the structure rigid, warped, or pliable? Did structural cracking occur? Are external materials or items damaged? Was damage caused by the overpressure (usually crushing), dynamic pressure (usually components torn off or moved), or secondary airborne debris damage (usually indicates an impact site)? Are any fluids leaking from the test item? Is the test item safe to enter and or climb on?

(2) The test item's functionality. If applicable, is the test item operational? If engine were operating, is it operating after event? If not, is it repairable? Does the test item meet the failure criteria established in paragraph 3.1.1?

(3) Instrumentation condition. Are all gages mounted and intact? Are data cables properly attached and undamaged?

h. The results of all the post-test checkouts should be recorded using Test Incident Reports (TIRs); detailed procedures on TIRs are contained in DTC PAM 73-1.

i. Compare the blast environment measurements with the expected environment; the peak static and dynamic overpressure expressed in kilo-Pascals (kPa), the positive phase and negative phase durations expressed in seconds, and the over pressure impulse (Static and Dynamic) expressed in Pascal-seconds (Pa-sec).

j. Compare the test results with the model predictions, factors of 2 are considered acceptable and adjust the model accordingly.

k. Test data and results, and pertinent information are archived into the test items Life-Cycle program database for future evaluations and assurance management.

#### 4.3 Synergistic Effects.

Synergistic Effects are evaluated by numerical or preferably finite element modeling. No facilities exist to provide thermal and blast synergism. A model of the system needs to be developed or modified from the test item CAD drawings, to include the material properties found in paragraph 3.1.3. This modeling provides a basic evaluation of the expected test item performance in lieu of test data.

#### 5. DATA REQUIRED.

- a. Description and findings of the pre-test investigation and simulations.
- b. Detailed description of the test item to include the following:
  - (1) Serial number.

- (2) Serial numbers for subcomponents (if applicable).
  - (3) Dimensions.
  - (4) Material Composition.
  - (5) MSDSs (if applicable).
  - (6) Photograph/video of pre-test and post test condition.
  - (7) Mechanical Drawings.
  - (8) Operating status and recovery procedures.
- c. Description of all inspections, performance, and operational baseline checks.
  - d. Description of the test facility and the method used to produce the blast environment.
  - e. Detailed descriptions of gages and mount locations to include test setup drawings or photographs.
  - f. Results of the data instrumentation measurements monitoring the test item response.
    - (1) Results of the blast test with the overpressure and pressure environment expressed in kilo-Pascal (kPa), pressure durations expressed in seconds (sec), Impulse expressed in kilo-Pascal seconds (kPa-sec), acceleration expressed in gravitational units (Gs) (i.e. full response, initial response and low frequency filtered), strain expressed in micro-strain, and displacement expressed in meters.
    - (2) Results of the thermal test with fluence expressed in Joules per square meter ( $J/m^2$ ) or calories per square centimeter ( $cal/cm^2$ ), flux expressed in Joules per square meter per second ( $J/m^2$ -sec) calories per square centimeter per second ( $cal/cm^2$ -sec), time to maximum irradiance expressed in seconds, and pulse width full width/half maximum (FWHM) expressed in seconds
  - g. Calculations used for data reduction.
    - (1) Over pressure impulse is calculated by integrating with respect to time the recorded pressure wave form (this can be done with Simpsons rule).
    - (2) Acceleration is the complete full response data recorded, the initial response is usually the first 100 milliseconds; low frequency filtering of the data is performed using fast Fourier transformation method and the performing and inverse transform up to the required cutoff frequency, typically 10 Hz and 100 Hz.
    - (3) Thermal fluence is calculated by integrating with respect to time the thermal flux.

- h. Archive of photographs/video of all pre-test and post- test visual inspections and test item response.
- i. Test conductor LOG of all functional checkouts, and recovery procedures performed.
- j. Copies of the TIRs.
- k. Analytical models, software utilized, materials list, model source, predicted results.

6. PRESENTATION OF DATA.

Data should be provided in DTC PAM 73-1 format which states the data should be reduced to tables, graphs, images and photos were possible.

- a. Tables may be used to present the following data:

(1) Equipment Test Matrix

Test Item Matrix			
Item	NSN/ Description	Serial Number	Location
system X	system being tested	1	
radio	SINCGARS	sync1	right middle incident side left rear non-incident
generator	onboard electric	g1	side

(2) Data acquisition system setup

Instrumentation Setup Sheet

Ch	Meas ID	Measurement Description	Measurement Type	Gage(SN)/ Range	Pred	Gain	Railed Signal	Engr Unit	Sample Rate (us)	Record Duration (sec)	Filter (kHz)
0	A1A	Hull (drivers area)	Acceleration	JQ06/1000	150	10	449.24	G	16	1.835	5
1	A1V	Hull (drivers area)	Accel	KW30/1000	190	20	484.53	G	16	1.835	5
2	A1L	Hull (drivers area)	Accel	JQ04/1000	215	10	442.95	G	16	1.835	5

(3) Test point data

Test Point Reduced Data

Ch	Gage Location	Gage	S/N	Gage Calibration Factor	Max	100Hz	10Hz
					Acceleration	max	Max
0	Hull (drivers area)	A1A	JQ06	0.56	51.205	32.4387	1.1814
1	Hull (drivers area)	A1V	KW30	0.26	56.7114	18.0457	4.6561
2	Hull (drivers area)	A1L	JQ04	0.56	24.9534	15.9802	3.2963

(4) Modeling and test point data comparisons

Test Point Analytical Data Comparison

Gage Location	Gage	Test Max Acceleration	Model Max Acceleration	Max Acceleration Delta %	Acceptable
Hull (drivers area)	A1A	51.205	100	200	Yes
Hull (drivers area)	A1V	56.7114	100	200	Yes
Hull (drivers area)	A1L	24.9534	50	200	Yes

b. Charts and graphs may be used to present the following data:

(1) Test environment and test item response data

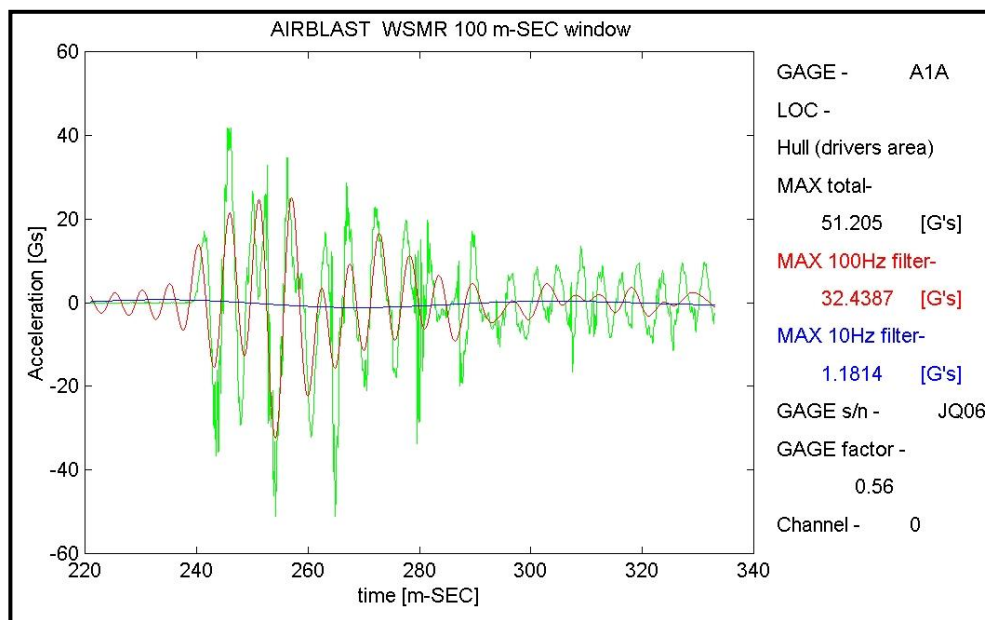
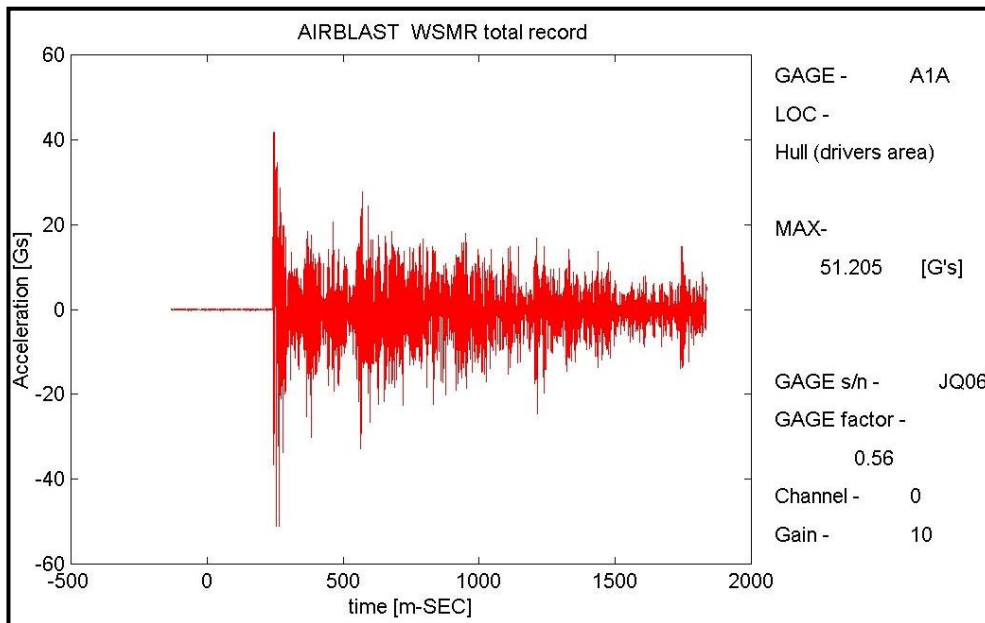

(2) FEA Modeling test item response data presented the same as above and the following data should be included; a stress, strain and displacement diagrams from the FEA modeling. The design margins on the test items FEA models maximum stress compared to the material Ultimate Tensile Strength and the Yield Stress should be calculated.

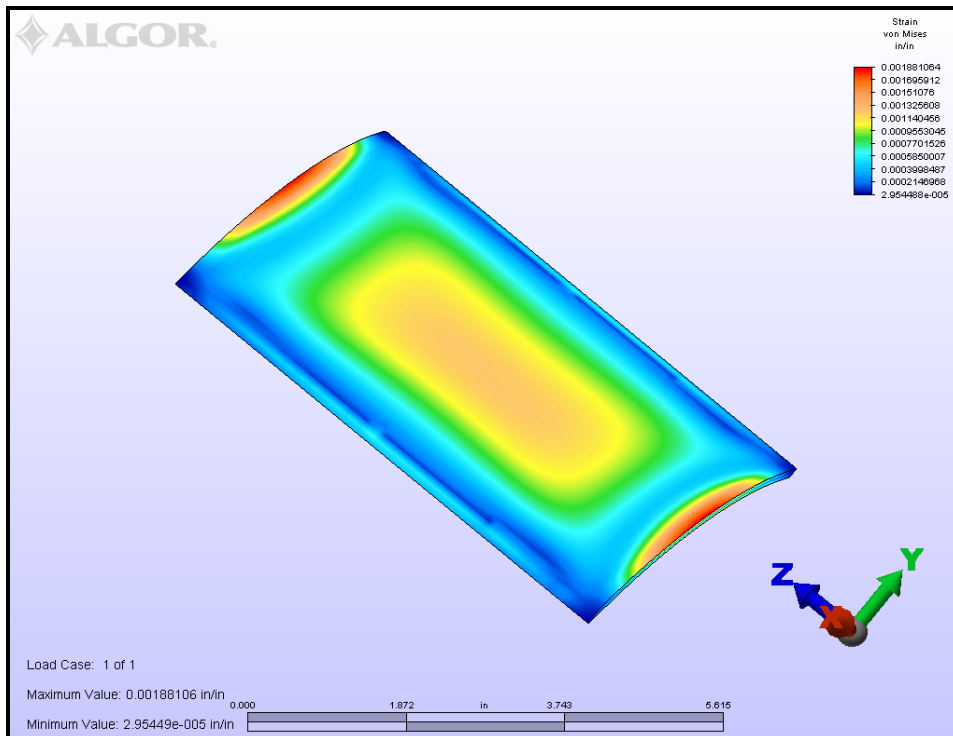
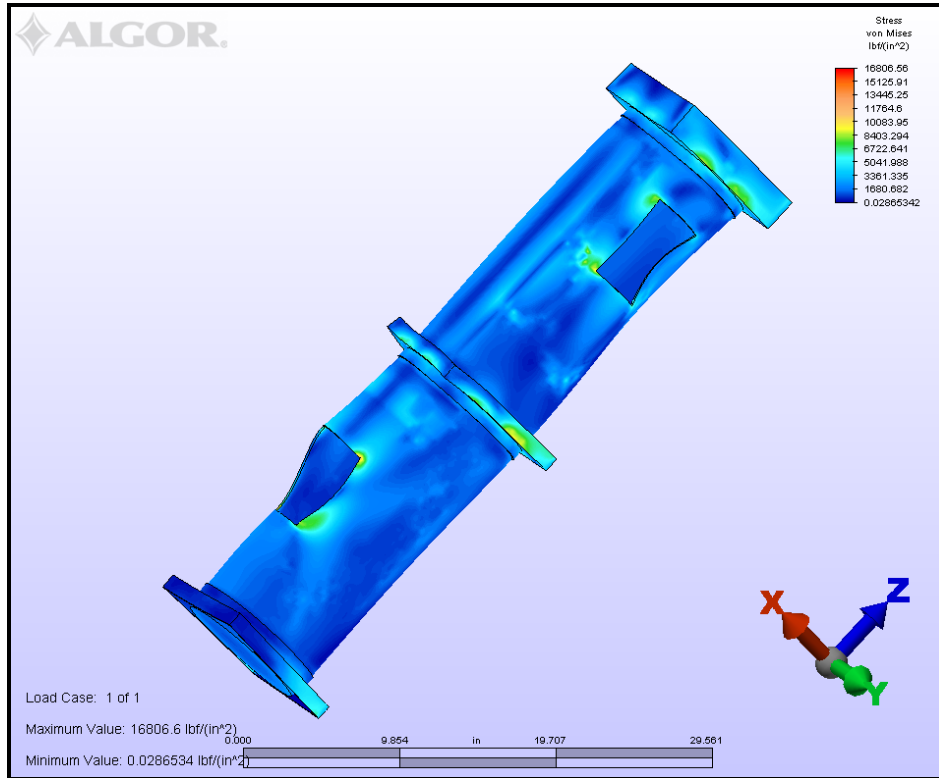

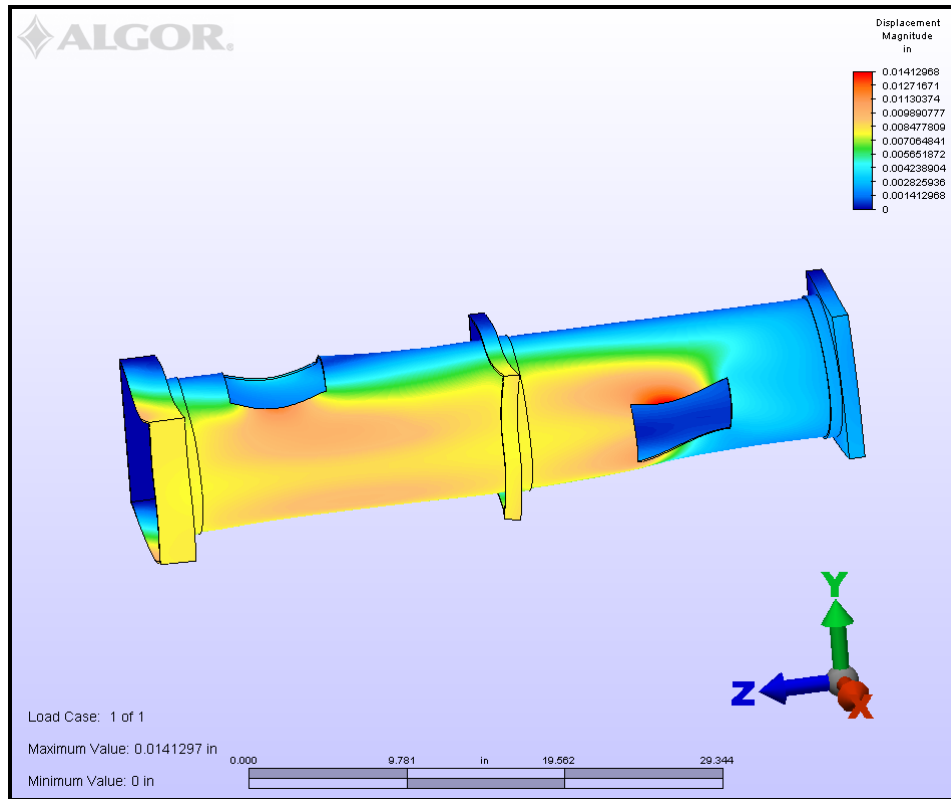

TEST ITEM INDUCED STRESS AND SAFETY MARGINS		
STRESS (psi)	ULTIMATE TENSILE STRESS (psi)	SAFETY MARGIN
14	5510	393.57
292	5510	18.86
663	5510	8.31
941	5510	5.85

- f. Drawings and photographs may be used to present the following data:
- (1) Test setup.
  - (2) Test item configuration.
  - (3) Instrumentation installation.
  - (4) Visible damage.

TOP 1-2-619  
3 November 2008



APPENDIX A. GENERAL GUIDELINES AND CALCULATIONS FOR NUCLEAR  
THERMAL

The thermal energy response of a material can be modeled using electrical lumped nodal analysis techniques. Table A-1 below provides the electrical to thermal analogies.

Table A-1. ELECTRIC TO THERMAL ANALOGY		
General	Electrical	Thermal
Flow Variable (through variable)	Current, $I = dq/dt$ [Amps]	Heat flow, $q$ [Joules/sec]
Potential Variable (across variable)	Voltage, $V$ [Volts]	Temperature difference, $T$ [°C]
Integrating Element (Delay Component)	Inductance, $L$ [Henrys] Faraday's Law: $I = \int V dt / L$	Not Applicable
Proportional Element (Dissipative Component)	Resistance, $R = \rho L/A$ [Ohms] Ohm's Law: $I = V/R$	Heat transfer resistance, $R$ $q = T / R$
Differentiating Element (Accumulative Component)	Capacitance, $C = \epsilon A/d$ [Farads] $I = C dV/dt$	Thermal heat capacity, $m c_p$ $q = m c_p dT/dt$
Other Variables	Charge, $q = \int I dt$ [Coulombs]	Heat, $Q = \int q dt$ [Joules]

Table A-2. MATERIAL PROPERTIES

	Density kg/m <sup>3</sup>	Specific Heat Cal/kg°C	Thermal Conductivity Cal/sm°C	Thermal Resistance sm°C/Cal	Width m	Simulation Area (vehicle side) m <sup>2</sup>	Electrical Capacitance Model Value Cal/°C	Electrical Resistance Model Value s°C/Cal
HULL								
AIR	1.2	239.8	6.12E-03	1.63E+02	1.2	9.5	2.73E+03	20.63309
Kevlar	1440	81.2	9.55E-03	1.05E+02	0.0127	9.5	1.41E+04	0.1399542
Steel	7850	103.659	14.447	6.92E-02	0.00635	9.5	4.91E+04	4.627E-05
Ceralloy (Ceramic Armor)	3210	143.33	26.26	3.81E-02	0.0254	9.5	1.11E+05	0.0001018
FUEL TANK								
JP8 (FULLTANK)	1298	632.95	0.027467	3.64E+01	0.0254	0.285	5.95E+03	3.244723
Steel	7850	103.659	14.447	6.92E-02	0.00635	0.285	1.47E+03	0.0015422
JP8 (HALFTANK)	1298	632.95	0.027467	3.64E+01	0.0254	0.142	2.96E+03	6.5122962
Steel	7850	103.659	14.447	6.92E-02	0.00635	0.285	1.47E+03	0.0015422
AIR (HALF ANK)	1.2	239.8	6.12E-03	1.63E+02	0.0254	0.142	1.04E+00	29.218105

Calculation of the circuit modeling component parameters for a material are based on the equations provided below:

1. Material properties:
  - a. Thermal resistance of material:

$$R = \frac{A}{kL}$$

A = Surface Area

k = Thermal Conductivity

L = Thickness

b. Thermal capacitance of material:

$$C = D \times L \times A \times Cp$$

D = Density

L = Thickness

A = Surface Area

Cp = Specific Heat

2. Dissipative elements:

a. Radiation Resistance:

$$Rr = \frac{T}{A \sigma \varepsilon (T_1^4 - T_o^4)}$$

T = temperature °C

T<sub>o</sub> = ambient temperature °K

T<sub>1</sub> = temperature °K

A = surface area

σ = Stefan – Boltzmann constant ( $1.35e^{-8} \frac{cal}{m^2 s^{\circ}C}$ )

ε = emissivity (assumed to be 0.2)

b. Convection Resistance:

$$Rc = \frac{T}{A \beta (T_1 - T_o)^{\frac{5}{4}}}$$

T = temperature °C

T<sub>o</sub> = ambient temperature °K

T<sub>1</sub> = temperature °K

A = surface area

β = coefficient of heat transfer

$0.5 \frac{cal}{m^2 s^{\circ}C}$  utilize (generic flat plate value)

Once the equivalent electrical parameters (component parameters) for a material are calculated, the system is modeled as a lumped node transmission line as in Figure A-1.

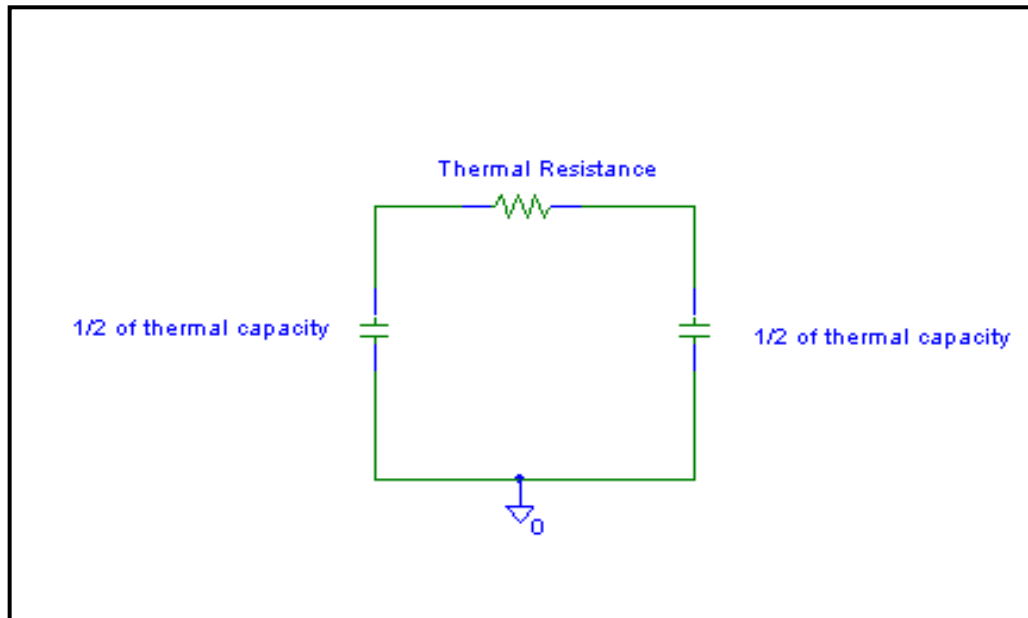

Figure A.1. Transmission Line Model of Material

The material layers are then combined to create an electrical circuit representation of their cross section, which can be driven by a thermal source. Modeling a section of the test item (using this method) and then performing the static calculation of temperature rise was performed as a check. This check was based on material, energy fluence, and included no losses. The modeling method resulted in a temperature rise of 2085 °C and the static calculation 2045 °C, this is a difference of approximately 2 percent.

VEHICLE HUB WINDOW AND OIL EXAMPLE. The thermal model of the HUB was developed by measuring the size of the check window and utilizing its area as the energy receiver. After the deposition of thermal energy the window size was then used to account for heat dissipation (no other materials or surfaces were included). The thermal parameter values of the materials are provided in Table A-2 , no values for gear oil could be found and therefore the parameters for JP8 were used (this should be conservative and the resulting electrical schematic is presented as Figure A-2. R5 is used to simulate the HUB radiation of energy back to the environment. The thermal source used for this stimulation is based on the piece-wise-linear model provided in the nuclear survivability criterion document. Please note that the distance from the window into the gear oil was varied to estimate temperature versus distance and is provided as FigureA-3.

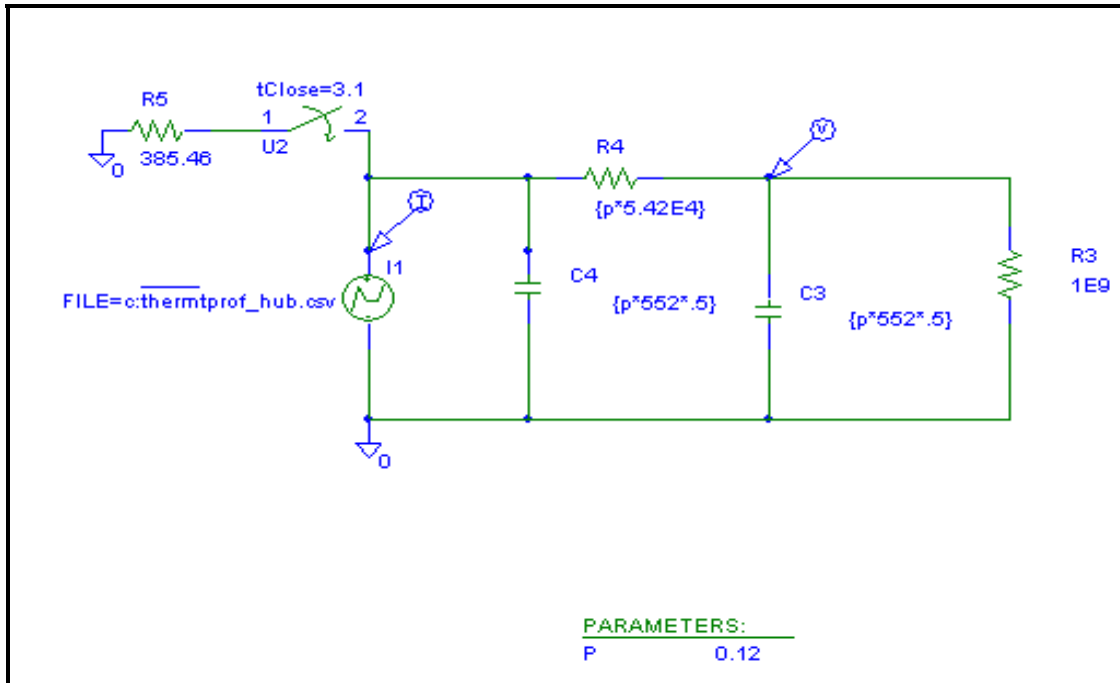

Figure A-2. HUB Thermal Model

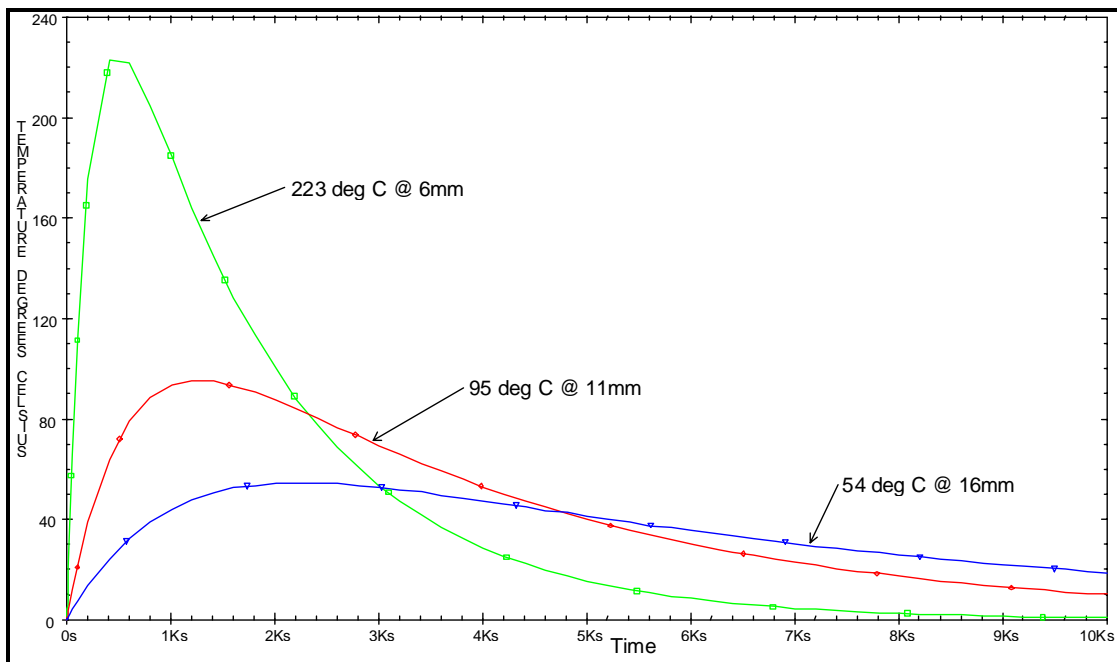

Figure A-3. Hub Oil Temperature

HUB: As can be seen from the simulation provided in Figure A-3 the thermal time constant for the HUB is large and the temperature lags the thermal input significantly. The gear oil located within 11mm of the sight glass will reach the boiling temperature of JP8 (86 °C). This indicates that the gear oil, which is over heated, will be changed and become a contaminant. The predicted volume, which will be overheated, is 7.39 cc. The HUB contains 900 cc; therefore the contaminant will be approximately 0.8 percent of the volume. The model does not include the following; the reduction in received energy due to ablation (the creation of smoke from the heated materials i.e. plastic), the material surrounding the sight glass, or the transport of energy due to boiling. Therefore, because of the small amount of gear oil being changed/contaminated it is not expected that the HUB performance will be affected.

APPENDIX B. GENERAL GUIDELINES AND CALCULATIONS FOR NUCLEAR BLAST

1. GENERAL FORCE APPLIED TO A SURFACE:

The numerical prediction method is; to project the vehicle surface onto a vertical plane, which is perpendicular to the incident blast wave, and then calculate the forces exerted on that surface. The defining equations used to predict the absolute worst-case forces on a surface are:

$$Force = P \times A$$

$$P = Pc + Pd + Pr$$

$$Pd \cong \frac{5}{2} \times \frac{Pc^2}{7Po + Pc}$$

$$Pr \cong 2P \frac{7Po + 4Pc}{7Po + p}$$

where :

P = pressure

Pc = criterion overpressure

Pd = peak dynamic pressure

Pr = peak reflected pressure

Po = atmospheric pressure [101.3 kPa (14.7 psi)]

kPa = kilo - Pascals

psi = pounds per square inch

2. ESTIMATING THE STRUCTURAL CAPABILITY:

VEHICLE HULL EXAMPLE: The dimensions model was developed from CAD drawings and uses the side of the vehicle with the largest area as the air blast receiver. This area is calculated as the projection of the surface onto a vertical plane perpendicular to the blast force. If the surface area of the blast incident side is 14.5 m<sup>2</sup> then the calculated pressure is 313.7 kPa (.314Mpa, 45.5 psi). This effort is performed only to determine if gross crushing or breaking could occur. The generic parameters of the structure materials were investigated using material databases and manufacturer information.

Estimated Material Properties				
	Yield strength Mpa	Yield strength ultimate Mpa	Shear Mpa	Modulus of Elasticity Mpa
Ceramic	1400	303000	-----	448000
Steel	379	455	80000	200000
Kevlar	-----	3000	-----	112000

The predicted absolute maximum pressure on the incident surface of the system was 313.7 kPa. Data on the materials indicates that this pressure is below the elastic strength of the materials by 3 orders of magnitude. Therefore, there is expected to be no appreciable deformation or ruptures of the structure.

### 3. GROSS SYSTEM ACCELERATION:

Data from like systems and experience should be used to estimate system responses if possible. As a minimal prediction, the gross or overall acceleration of a system due to the air blast environment is primarily produced by the dynamic pressure (i.e. wind pressure). The gross low frequency acceleration of the system is then calculated using the equations below:

$$F = M \times A$$

$$A = \frac{F}{M}$$

$$A(g's) = A / Ag$$

$$F = \text{force [newtons]}$$

$$M = \text{mass [kg]}$$

$$Ag = \text{acceleration due to gravity [9.8 } \frac{\text{m}}{\text{s}^2}\text{]}$$

Utilizing the area of the vehicle as 14.7 m<sup>2</sup>, the predicted force as 3.08e5 Newton, and the mass of the vehicle expressed as 17237 kg (38000 lbs); the resulting predicted low frequency base acceleration is 17.87 m/s<sup>2</sup> or 1.8 g. Data measured during testing include high frequency and impact accelerations; the base vehicle acceleration is obtained by filtering the data. Recorded data show, when using a 10Hz filter, the low frequency acceleration is between 1.8 G and 3 Gs, which is in agreement with the calculation. However, the full frequency waveform had a maximum of 51 Gs which is a factor of 29 times greater than the base low frequency calculation. This implies that when making the gage predictions a factor of 50 (minimum value) should be used and in general a multiplication factor of 100 is preferred. When making prediction on internal rack mounted equipment this factor should be increased by an additional multiplication factor of 2. Given this estimate, the major frame accelerations would be predicted to be 180 Gs and the instrumentation would be set so that the gage output signal after amplification would be 50% of the data recorder maximum voltage thereby providing for a quality recording of the signal from approximately 25 to 200% of the prediction. The same procedure would be used for the rack/vibration mounted equipment except the original figure would be 200 instead of 100 or a prediction of 360 Gs.

APPENDIX C. GENERAL GUIDELINES FOR FINITE ELEMENT ANALYSIS (FEA) FOR  
NUCLEAR BLAST, THERMAL, AND SYNERGISTIC EFFECTS

1. GENERAL GUIDELINES FOR FEA MODELING FOR NUCLEAR BLAST:

a. Develop a three dimensional CAD computer model of the test item as displayed in Figure C-1 that can be used to perform Finite Element Analysis (FEA). The FEA can be performed utilizing any software that can perform static and dynamic overpressure calculations on the FEA model, the software used here was ALGOR.

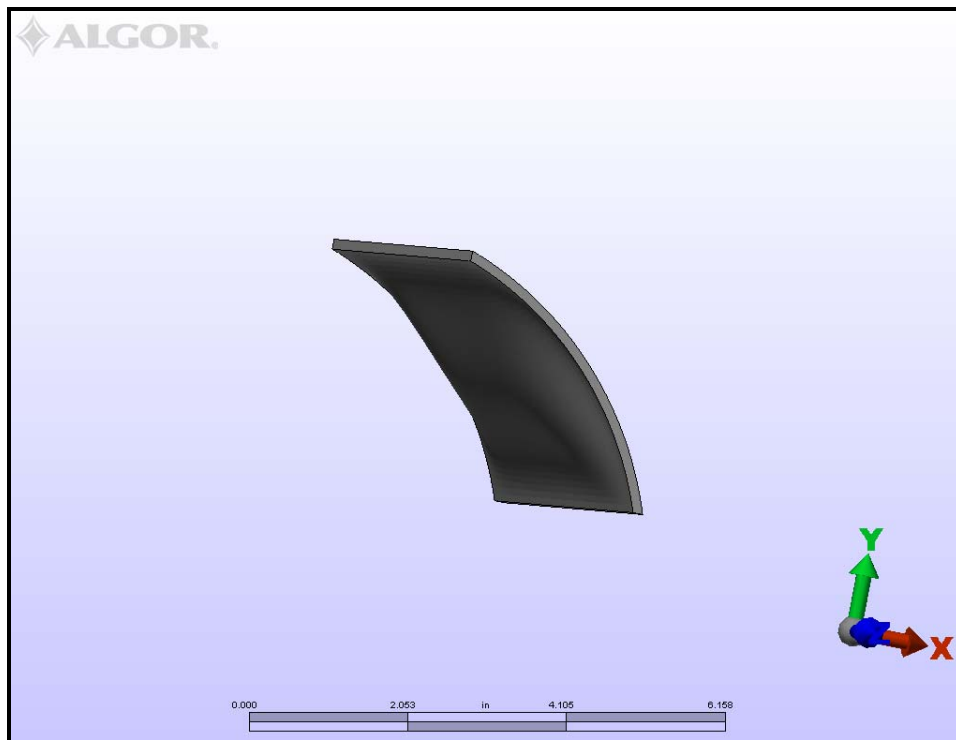

Figure C-1. Test Item FEA Analysis Model

b. Equivalent Static overpressure and Dynamic pressure loads need to be calculated (as described in Appendix B) and applied to the outside surfaces, on the blast incident source side of the test item three dimensional FEA model. Stress, strain and deflection values can then be computed on the FEA model as displayed in Figure C-2 utilizing the software.

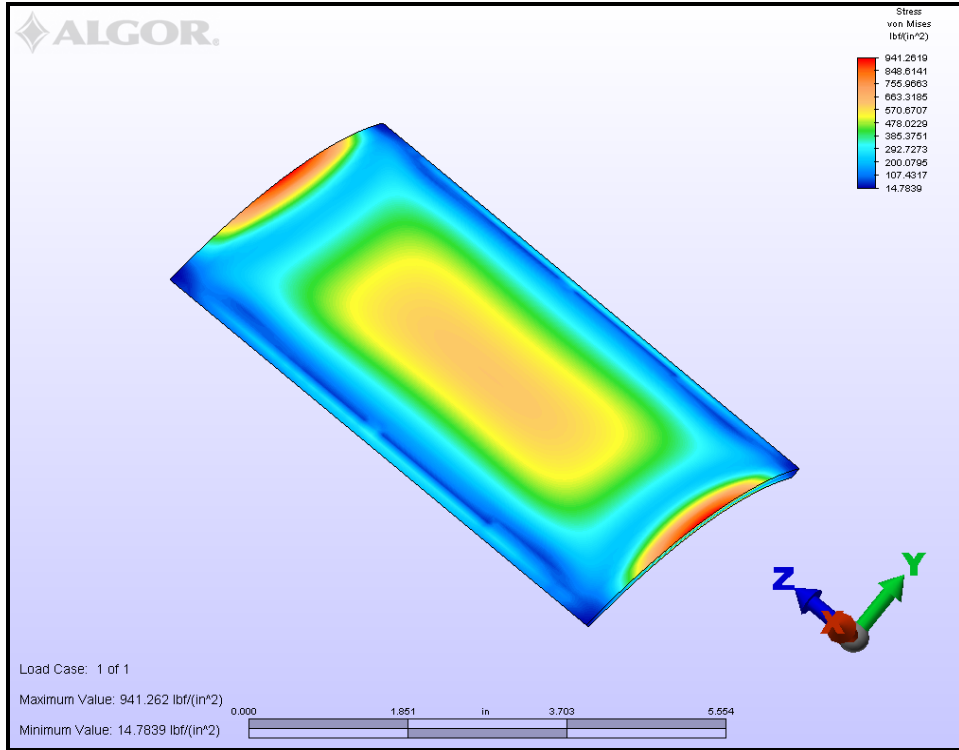

Figure C-2 Test Item FEA Stress Analysis Results

c. The maximum stresses on the test item are determined from the FEA results and then compared to the Ultimate tensile strengths and the Yield strengths of the test item material properties. Design margins can then be calculated based on the FEA analysis results and material properties. Design Margins of 1.5 or greater are desired so that the probability of the item failing under the load will be low.

d. Figure C-2 presents the stress for the test item calculated with the ALGOR FEA software. The test item will reach a maximum stress of 941 psi on the outer center edges of the window cover. The maximum stress values are represented by the red colored area in the FEA model. The majority of the test item experiences stress levels from approximately 14 psi to 570 psi, which is well below the Ultimate Tensile Strength of 5,510 psi for the window cover material. The safety margins of the test item compared to the Ultimate Tensile Strength of the test items material properties are presented in Table C-1.

Table C-1. Safety Margins on XM982 Canister Formion Window Cover Stresses

STRESS (psi)	ULTIMATE TENSILE STRESS (psi)	SAFETY MARGIN
14	5510	393.57
292	5510	18.86
663	5510	8.31
941	5510	5.85

2. GENERAL GUIDELINES FOR NUCLEAR THERMAL FEA MODELING:

a. Develop a three dimensional CAD computer model of the test item as displayed in Figure C-3 that can be used to perform the Thermal FEA analysis. The Thermal FEA analysis can then be performed utilizing any software that can perform transient thermal calculations on the thermal FEA model.

b. The required thermal loads can then be applied to the outside surfaces, on the thermal incident source side of the test item three dimensional FEA model. Temperature and Heat Flux values can then be computed for the FEA model as displayed in Figure C-3 which are the temperature results utilizing ALGOR FEA software. Temperature values should also be calculated for the three different materials of the test item at various applied thermal energies using the methods provided in Appendix B and compared to thermal FEA results.

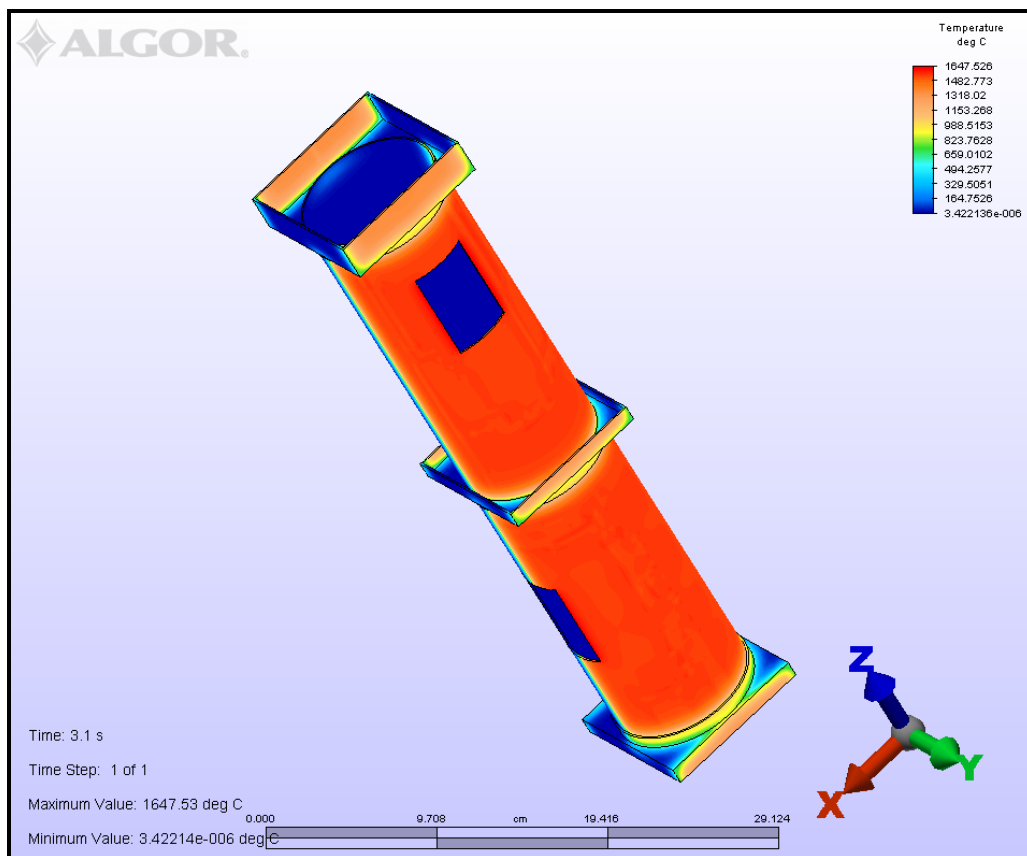

Figure C3. Test Item ALGOR Thermal FEA Temperature Results

c. The Thermal Finite Element Analysis performed using ALGOR shows the steel canister reaching temperatures of 1647°C. Comparing the value calculated as in Appendix B, which is 1520°C to the results from FEA the values are within 8%. At these temperatures, any polymer or material that has a lower melting temperature in the test item will ignite. The test item will be close to its melting temperature of 1440°C - 1520°C.

### 3. GENERAL GUIDELINES FOR NUCLEAR FEA MODELING SYNERGISTIC EFFECTS

A final analysis of the test item that includes both Thermal and Blast loads should be conducted. The maximum stresses and temperatures on the test item can then be determined from the FEA results and then compared to the temperature modified Ultimate tensile strengths and the Yield strengths of the test item materials properties. Design margins can then be calculated based on the results and material properties. Design margins of 1.5 or greater are desired so that the probability of the item failing under the thermal and blast loads will be low.

APPENDIX D. NUCLEAR THERMAL ENVIRONMENT

1. The following summary is an excerpt from Department of the Army Pamphlet No. 50-3<sup>2</sup> and is provided as background information only, typical system test requirements are provided in the system criterion documents. Figure D-1 provides the energy distribution and Figure D-2 the time line for a generic small yield nuclear detonation.

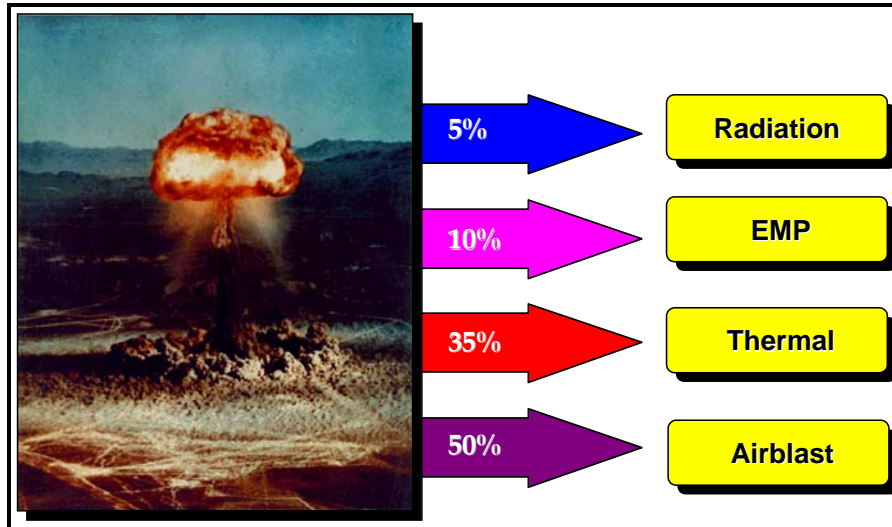

Figure D-1 Weapon Energy Distribution

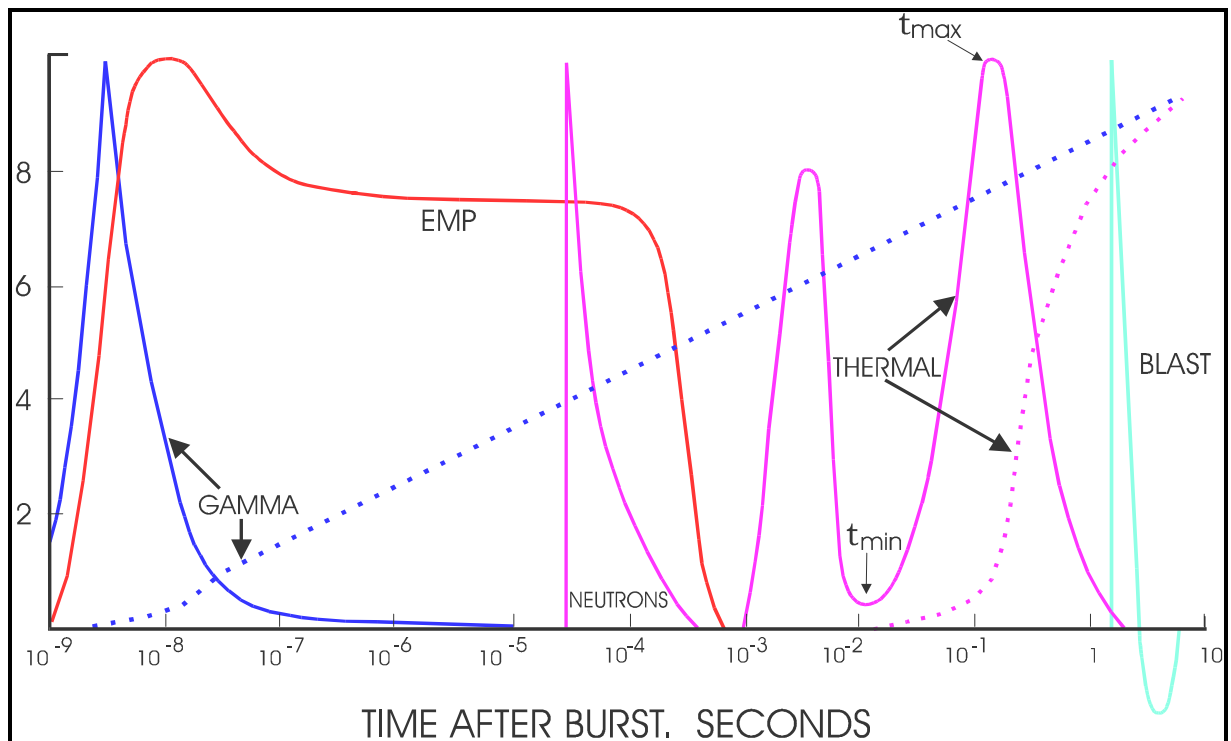

Figure D-2 Nuclear Weapon Detonation Time History

2. One of the important differences between a nuclear and a conventional high-explosive weapon is the large proportion of the energy of a nuclear explosion which is released in the form of thermal (or heat) radiation. Enormous amount of energy liberated per unit mass in a nuclear weapon. As much as 75% is released as X-rays that are absorbed within a meter of surrounding air, thus generating very high temperatures and a “fireball”. The temperatures are estimated to be several tens of million degrees, compared with a few thousand degrees in the case of a conventional explosion. For practical purposes, it is estimated that 35 percent of the total yield of an air burst is emitted as thermal radiation energy. This means that for every 1 kiloton TNT equivalent of energy release, about 0.35 kiloton, i.e.,  $3.5 \times 10^{11}$  calories or about 410,000 kilowatt-hours, is in the form of thermal radiation. The thermal radiation leaving the fireball covers a wide range of wavelengths, from the short ultraviolet, through the visible, to the infrared region.

3. The curves in Figure D-3 show the variation with the scaled time,  $t/t_{max}$  of the scaled fireball power,  $P/P_{max}$  and of the percent of the total thermal energy emitted,  $E_{max}/E_{tot}$ , in the thermal pulse of an air burst. The time after the explosion for the temperature maximum in the second thermal pulse is  $t_{max}$ ,  $P_{max}$  is the maximum rate (at  $t_{max}$ ) of emission of thermal energy from the fireball, and  $E_{tot}$  is the total thermal energy emitted by the fireball.

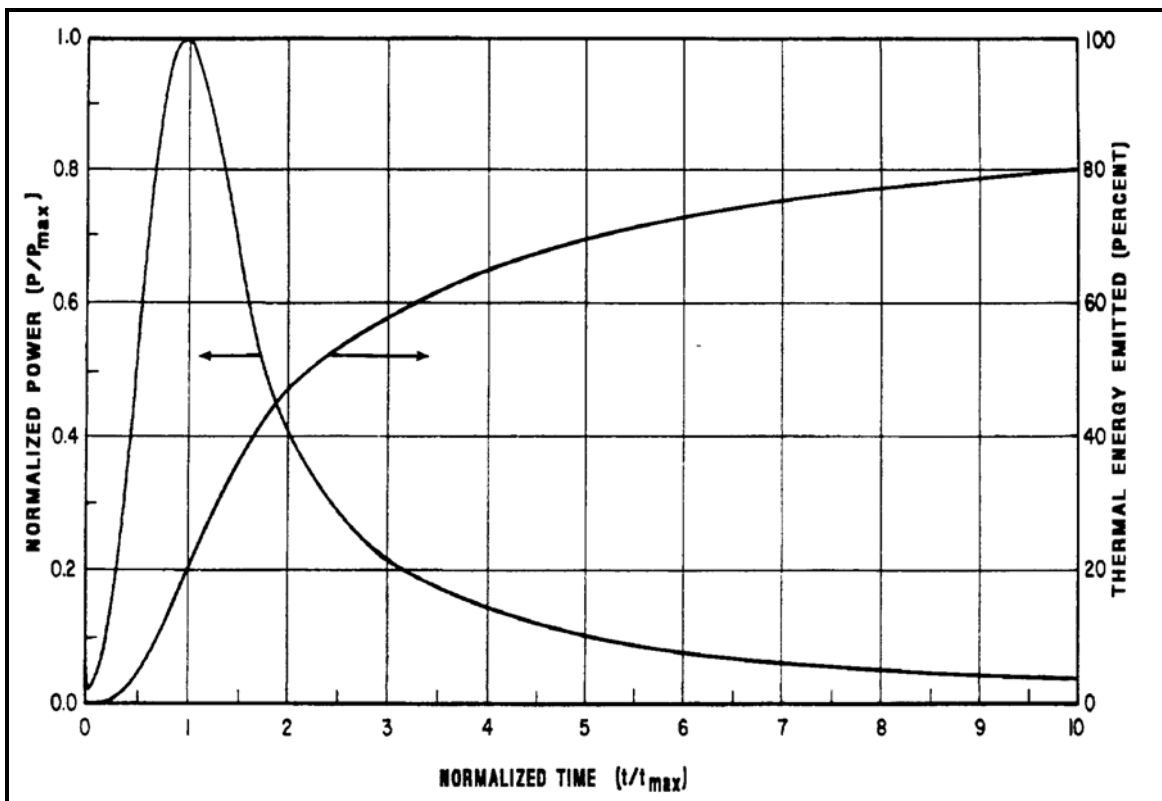

Figure D-3. Scaled (or normalized) Fireball Power and Fraction of Thermal Energy Emitted Versus Scaled (or normalized) Time in the Thermal Pulse of an Air Burst Below 100,000 ft

4. The extent of injury or damage caused by thermal radiation or the chance of igniting combustible material depends to a large extent upon the amount of thermal radiation energy received by a unit area of exposed material within a short interval of time. The thermal energy falling upon a given area from a specified explosion will be less farther from the explosion, for two reasons: (1) the spread of the radiation over an ever increasing area as it travels away from the fireball, and (2) attenuation of the radiation in its passage through the air. If the radiation is distributed evenly in all directions, then at a distance  $D$  from the explosion the same amount of energy will fall upon each unit area of the surface of a sphere of radius  $D$ . The energy received per unit area at a distance  $D$  would be  $E/4\pi D^2$  where  $E$  is the thermal radiation energy produced in the explosion. This quantity varies inversely as the square of the distance from the explosion. In order to estimate the amount of thermal energy actually reaching the unit area, allowance must also be made for the attenuation of the radiation by the atmosphere. This attenuation is due to two main causes: absorption and scattering. Atoms and molecules present in the air are capable of absorbing certain portions of the thermal radiation. Absorption is most effective for the shorter wavelength rays. Attenuation as a result of scattering occurs with radiations of all wavelengths. Scattering can be caused by molecules present in the air but is much more effective when caused by the reflection and diffraction of light rays by particles of dust, smoke, or fog in the atmosphere. Scattering leads to a diffused rather than direct transmission of the thermal radiation.

5. When thermal radiation falls upon any material or object, part may be reflected, part will be absorbed, and the remainder, if any, will pass through and ultimately fall upon other materials. It is the radiation absorbed by a particular material that produces heat and so determines the damage suffered by that material. The extent or fraction of the incident radiation that is absorbed depends upon the nature and color of the material or object. Highly reflecting and transparent substances do not absorb much of the thermal radiation and so they are relatively resistant to its effects. An important factor in connection with material damage due to thermal radiation is the rate at which the thermal energy is delivered. For a given total amount of thermal energy received by each unit area of exposed material, the damage will be greater if the energy is delivered rapidly than if it were delivered slowly.

6. The amount of thermal energy falling upon a unit area exposed to a nuclear explosion depends upon the total energy yield, the height of burst, the distance from the explosion, and the atmospheric conditions. Although extensive studies have been made of the effects of thermal radiation on a large number of individual materials, it is difficult to summarize the results because of the many variables that have a significant influence.

7. However, a general description of the effect on various common materials can be provided. Fabrics made of natural fibers, e.g., cotton and wool, and some synthetic materials, e.g., rayon, will scorch, char, and perhaps burn; nylon, on the other hand, melts, when heated to a sufficient extent. Wood is charred by exposure to thermal radiation, the depth of the char being closely proportional to the radiant exposure. For sufficiently large amounts of energy per unit area, wood in some massive forms may exhibit transient flaming but persistent ignition is improbable under the conditions of a nuclear explosion. However, in a more-or-less finely divided form, such as sawdust, shavings, or excelsior, or in a decayed, spongy state, wood can be ignited fairly readily. Glass is highly resistant to heat, but as it is very brittle it is sometimes replaced by transparent or translucent plastic materials or combined with layers of plastic to make it shatterproof. These plastics are organic compounds and so are subject to decomposition by heat. Surface melting or darkening can be expected at thermal energy levels of at least 60 to 70 cal/cm<sup>2</sup>. Metal structures are primarily affected by a weakening of the metal's yield strength due to an increase in temperature from the absorbed heat. Heat absorbing paint is commonly used to protect metal structures from thermal radiation. The burning or charring paint absorbs the heat and thus protects the underlying metal surface; plus, the smoke produced screens the surface from further exposure.

APPENDIX E. NUCLEAR BLAST ENVIRONMENT

1. The following summary is an excerpt from Department of the Army Pamphlet No. 50-3<sup>2</sup> and is provided as background information only, typical system test requirements are provided in the system criterion documents. Additional details are in Gladstone, The Effects of Nuclear Weapons. Figure D-1 provides the energy distribution and Figure D-2 the time line for a nuclear detonation.
2. The expansion of the intensely hot gases at extremely high pressures in the fireball of a nuclear weapon explosion causes a shock wave to form, moving outward at high velocity. Most of the material damage caused by a nuclear explosion at the surface or at a low or moderate altitude in the air is due to the shock (or blast) wave which accompanies the explosion.
3. It is of interest to examine the changes of overpressure and dynamic pressure with time at a fixed location (see Figure E-1), for a short interval after the detonation, there will be no change in the ambient pressure because it takes some time for the blast wave to travel from the point of the explosion to the given location. This time interval known as arrival time depends upon the energy yield of the explosion and the slant range. When the shock front arrives at the observation point, the overpressure (the excess pressure over the atmospheric pressure) will increase sharply from zero to its maximum (peak) value. Subsequently, the overpressure decreases. The overpressure drops to zero in a short time, and this marks the end of the positive phase. The duration of the overpressure positive phase increases with the energy yield and the distance from the explosion.

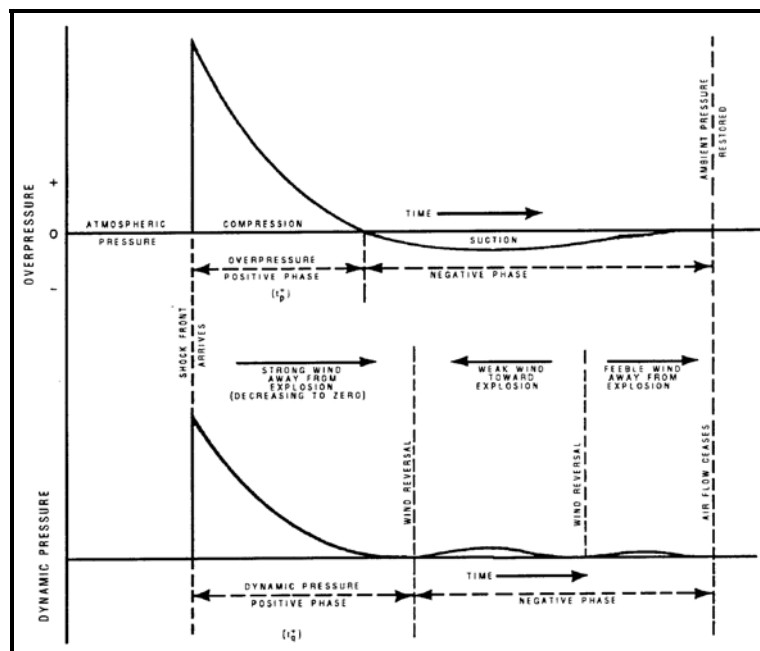

Figure E-1. Variation of Overpressure and Dynamic Pressure with Time at a Fixed Location

4. Provided the observation point is at a sufficient distance from the explosion, the overpressure will continue to decrease after it falls to zero so that it becomes negative. During this negative phase, the pressure in the shock wave is less than the ambient atmospheric pressure. After decreasing gradually to a minimum value, the pressure starts to increase until it becomes equal to the normal atmospheric pressure, and the overpressure is zero again.

5. The destructive effects of the blast wave are frequently related to values of the peak overpressure, but there is another important quantity called the "dynamic pressure." The dynamic pressure is proportional to the square of the wind velocity and to the density of the air behind the shock front. It is a measure of the kinetic energy of a certain volume of air behind the shock front. For a great variety of building and vehicle types, the degree of blast damage depends largely on the drag force associated with the strong winds accompanying the passage of the blast wave. Changes in the wind and in the associated dynamic pressure accompany the changes with time of the overpressure. Nearly all the direct damage caused by both overpressure and dynamic pressure occurs during the positive overpressure phase of the blast wave.

6. A structure is subjected to three different types of loading due to the blast wave: diffraction, compression, and drag. Diffraction loading is the force produced on the faces of a structure as the blast wave engulfs the structure completely. The pressure differential on the faces of the structure produces a lateral (or translational) force tending to cause the structure to deflect and move in the direction of the blast wave. Once the blast wave completely engulfs the structure, the diffraction loading is replaced by an inwardly directed pressure which produces compression loading. During the whole of the overpressure positive phase a structure will be subjected to the dynamic pressure loading (drag loading) which will also produce a translational force in the direction of the blast wave velocity. Under non-ideal surface conditions a blast wave precursor may form and subject a structure to a dynamic pressure drag loading of varying strength prior to the maximum overpressure diffraction loading.

7. Except at high blast overpressures, the dynamic pressures at the face of a structure are much less than the peak overpressures due to the blast wave and its reflection. However, the drag loading on a structure persists for a longer period of time, compared to the diffraction loading.

8. Attention may be called to an important difference between the blast effects of a nuclear weapon and those due to a conventional high-explosive bomb. In the former case, the combination of high peak overpressure, high wind (or dynamic) pressure, and longer duration of the positive (compression) phase of the blast wave results in mass distortion of buildings, similar to that produced by earthquakes and hurricanes. An ordinary explosion will usually damage only part of a large structure, but the blast from a nuclear weapon can surround and destroy whole buildings in addition to causing localized structural damage. Thus, it is the effect of the duration of the drag loading on structures which constitutes an important difference between nuclear and high-explosive detonations. For the same peak overpressure in a blast wave, a nuclear weapon will prove to be more destructive than a conventional one, especially for structures which respond to drag loading. This is because the blast wave is of much shorter duration for a high-explosive weapon. As a consequence of the longer duration of the positive phase of the blast wave from weapons of high energy yield, such devices cause more damage to drag sensitive structures than might be expected from the peak overpressures alone.

APPENDIX F. ACRONYMS

CAD	Computer Aided Drafting
DA	Department of the Army
DOD	Department of Defense
FEA	Finite Element Analysis
FWHM	Full Width/Half Maximum
HAMS	Hardness Assurance, Maintenance, and Surveillance
LB/TS	Large Blast Thermal Simulator
MSDS	Material Safety Data Sheet
NWE	Nuclear Weapons Effects
PAM	Pamphlet
PMO	Program Manager's Office
SVAD	Survivability Vulnerability and Assessment Directorate
TIR	Test Incident Report
TOP	Test Operations Procedure
WMSR	White Sands Missile Range



APPENDIX G. REFERENCES

1. DTC PAM 73-1, Developmental Test Guide, US Army Developmental Test Command, 30 October 2006
2. Army Pamphlet 50-3, The Effects of Nuclear Weapons, Department of the Army, March 1977

FOR INFORMATION ONLY

- a. Test Operations Procedure 1-2-612, Nuclear Environment Survivability, 27 October 2008.
- b. Army Regulation 70-75, Survivability of Army Personnel and Materiel, 2 May 2005.
- c. Department of Defense Instruction 5000.2, Defense Acquisition Management Policies and Procedures, 23 Oct 2000.
- d. Army Nuclear Hardening Criterion for system under test
- e. Technical Report, DASIAC-SR-92-006, Guide to Nuclear Weapons Effects Simulation Facilities and Techniques - 1992 Edition, Defense Nuclear Agency, April 1993.
- f. G.C. Messenger and M.S. Ash, The Effects of Radiation on Electronic Systems, published by Van Nostrand Reinhold, 1986.
- g. S. Glasstone and P.J. Dolan, The Effects of Nuclear Weapons, published by United States Department of Defense and United States Department of Energy, 1977.
- h. Illinois Institute of Technology Research Institute, Nuclear Weapon Effects Class Notes, 1991.
- i. White Sands Nuclear Effects Facility Technical Capabilities, Nuclear Effects Directorate, 1992.
- j. QSTAG 244, Edition 4: Nuclear Survivability Criteria for Military Equipment, 19 Jan 93.
- k. QSTAG 620: Nuclear Survivability Criteria for Communications-Electronics Equipment, 27 Oct 80.
- l. QSTAG 620, Edition 2: Nuclear Survivability Criteria for Communications-Electronics Equipment, 29 Jan 93.



Forward comments, recommended changes, or any pertinent data which may be of use in improving this publication to the following address: Test Business Management Division (TEDT-TMB), US Army Developmental Test Command, 314 Longs Corner Road Aberdeen Proving Ground, MD 21005-5055. Technical information may be obtained from the preparing activity: Nuclear Effects Division, (TEDT-WSV-N), US Army White Sands Missile Range, White Sands Missile Range, NM 88002-5158. Additional copies can be requested through the following website: <http://itops.dtc.army.mil/RequestForDocuments.aspx>, or through the Defense Technical Information Center, 8725 John J. Kingman Rd., STE 0944, Fort Belvoir, VA 22060-6218. This document is identified by the accession number (AD No.) printed on the first page.