



Key Elements in Fielding Capabilities

John D. Holcomb and Michael Hoehn
76th Software Maintenance Group

Organizations that develop software for the Department of Defense must have knowledgeable people to do the work according to documented and mature processes and standards that guide how the work is accomplished. The organization must also have in place the hardware and tools that are used to execute the processes to develop and test the end products. Success of their efforts depends on two key elements: the fidelity of the test environment, and the amount of collaboration with other agencies involved in their program.

The mission of the 76th Software Maintenance Group (SMXG, formerly MAS) at the Oklahoma City-Air Logistics Center, Tinker Air Force Base (AFB), Okla., includes positioning operational capabilities in the field, and improving and adding to them through software development and sustainment. The 76th SMXG performs this mission for the E-3, B-1, B-2, and B-52 aircraft, and for the Air Launched Cruise Missile (ALCM), Conventional Air Launched Cruise Missile (CALCM), and Advanced Cruise Missile (ACM) weapons. The group also has extensive capability for development and maintenance of Test Program Set hardware and software for automatic test equipment; industrial automation; and jet engine testing, trending, and diagnostics.

Any organization that develops or maintains weapon system software must have certain resources in place. These resources include people, a development environment, a test environment, tools, and facilities to house these resources. Policies, instructions, standards, and processes are required to control how the work is accomplished. Measurement and metrics requirements must be established to facilitate tracking workload/labor; to evaluate financial and project performance; and to establish the foundations for pricing future projects, making management decisions, and process improvement efforts. We have an outstanding Software Engineering Process Group (SEPG) that organizes and develops processes and standards, and maintains them online. It also establishes and manages our measurement and metrics requirements and process improvement efforts and the organizational software quality program.

The 76th SMXG consists of approximately 500 engineers, computer scientists, and staff personnel, the majority of whom have in excess of 15 years experience in the organization. Various development environments are used based on the weapon system or automatic test equipment that the appli-

cation software runs on, however, most applications are developed on IBM mainframes, Sun workstations, or networked personal computers. Tools used include assemblers, compilers, and tools for project planning and management, labor tracking, requirements tracking, configuration management, documentation, etc. A detailed discussion of all aspects of our operation is not possible within the scope of this article, and most readers are aware of these aspects from their own experience. Thus this article will focus on two key areas that reduce risk when fielding operational capabilities: high fidelity test environments and collaboration.

High Fidelity Test Environments

The test environment is one of the key elements in fielding capabilities. If it does not emulate the fielded system to the maximum extent possible, then the risk of operational problems when the software is fielded increases. The initial Avionics Integrated Support Facility Military Construction Project at Tinker AFB was built in the early 1980s to provide floor space to house the software support personnel and development environments for the E-3, B-52, Short Range Attack Missile (SRAM), and the ALCM. An example of our high fidelity test environments, the B-52 Avionics Integrated Support Facility (AISF), is a hot mockup of the aircraft avionics interfaced with the controls and displays. Simulated dynamics of the aircraft are provided by a vehicle system simulator, and weapon simulation is provided by a weapon system simulator.

The SRAM and ALCM laboratory area was built adjacent to the B-52 AISF area. The cruise missile project provided interfaces between the B-52 AISF and empty/loaded pylon/launcher station as well as between the AISF and the ALCM subsystem simulator. This test environment is used for simulation and test of the B-52 operational flight software, the aircraft to missiles interfaces, and the missile operational flight software. By utilizing the com-

bination of the B-52 AISF and pylon or launcher loaded with test missiles, all communication between the aircraft and missiles can be effectively tested. The SRAM program has been disposed of and the missile laboratory has evolved through the years to include capability for ACM and CALCM.

A missile electronic subsystem simulator, consisting of a table of interfaced missile electronics, is also available. Breakout boxes can be used at the umbilical connector, or at any of the internal missile interface connectors to allow monitoring of the interfaces. Testing of the B-52 operational flight software and missile operational flight program is accomplished by first planning the mission, then flying the aircraft mission on the AISF, rotating the launcher to the proper missile, if necessary, then simulating launch, and finally simulating free flight of the missile to target.

The AISF interface with the ALCM subsystem simulator is used to test aircraft/missile interface up to launch and subsequently test free-flight simulation of the missile operational flight program from launch to detonation at target. Successful testing of B-52 and missile operational flight software and mission planning software in this laboratory provides very high confidence that flight testing will be successful and that the software will provide the required capability when fielded.

A government owned and operated test environment for weapon systems has benefits other than the ability to fully test the software. Having this capability in a government facility allows it to be used for competitive procurement of projects that are beyond organic capability. For example, a B-52 modification was programmed and funded, but the sole-source contractor's price for developing the modification at the company's facility was in excess of the budget. We recommended to the program office that the project be competitively procured based on performance in our government facility. The effort was competed, development and

Report Documentation Page

*Form Approved
OMB No. 0704-0188*

Public reporting burden for the collection of information is estimated to average 1 hour per response, including the time for reviewing instructions, searching existing data sources, gathering and maintaining the data needed, and completing and reviewing the collection of information. Send comments regarding this burden estimate or any other aspect of this collection of information, including suggestions for reducing this burden, to Washington Headquarters Services, Directorate for Information Operations and Reports, 1215 Jefferson Davis Highway, Suite 1204, Arlington VA 22202-4302. Respondents should be aware that notwithstanding any other provision of law, no person shall be subject to a penalty for failing to comply with a collection of information if it does not display a currently valid OMB control number.

1. REPORT DATE AUG 2005		2. REPORT TYPE		3. DATES COVERED 00-00-2005 to 00-00-2005	
4. TITLE AND SUBTITLE Key Elements in Fielding Capabilities				5a. CONTRACT NUMBER	
				5b. GRANT NUMBER	
				5c. PROGRAM ELEMENT NUMBER	
6. AUTHOR(S)				5d. PROJECT NUMBER	
				5e. TASK NUMBER	
				5f. WORK UNIT NUMBER	
7. PERFORMING ORGANIZATION NAME(S) AND ADDRESS(ES) 76th Software Maintenance Group, 4750 Staff Dr, Tinker AFB, OK, 73145-3318				8. PERFORMING ORGANIZATION REPORT NUMBER	
9. SPONSORING/MONITORING AGENCY NAME(S) AND ADDRESS(ES)				10. SPONSOR/MONITOR'S ACRONYM(S)	
				11. SPONSOR/MONITOR'S REPORT NUMBER(S)	
12. DISTRIBUTION/AVAILABILITY STATEMENT Approved for public release; distribution unlimited					
13. SUPPLEMENTARY NOTES CROSSTALK The Journal of Defense Software Engineering, August 2005					
14. ABSTRACT					
15. SUBJECT TERMS					
16. SECURITY CLASSIFICATION OF:			17. LIMITATION OF ABSTRACT	18. NUMBER OF PAGES	19a. NAME OF RESPONSIBLE PERSON
a. REPORT unclassified	b. ABSTRACT unclassified	c. THIS PAGE unclassified			

testing was accomplished in the AISF by the winning contractor, and the final cost was approximately one half of the original bid.

Another additional benefit is the expertise that organic personnel develop as a result of having this type of laboratory. An example of this occurred after two B-52/ALCM-W80-1 Joint Test Assembly (JTA) flight tests resulted in aborted launches with total mission failure. An analysis of the mission data indicated a problem between the B-52 offensive avionics system (OAS) and the missile test payload (W80-1 JTA). After returning to the home base, the aircraft underwent extensive ground testing by Air Force personnel and no problem could be found. Sandia National Laboratories performed a series of comprehensive tests on their JTA package and concluded that it did not contribute to the aborted launches. Sandia further prepared a letter to the Cruise Missile Product Division detailing their findings and recommending the Air Force suspend future B-52/ALCM JTA flight tests until the Air Force could identify the source and correct the problem.

This problem was referred to our engineers, and the B-52/missiles laboratories were configured for an ALCM JTA launch using missile and B-52 production hardware and operational software. Utilizing state-of-the-art recording and analysis tools, engineers performed multiple JTA launches. Analysis of the laboratory flight test data and the JTA data from the aborted launches clearly determined that the aborted launches were a result of the JTA package. Having determined the source of the problem, engineers from the AISF presented their findings identifying the JTA as the source of the problem and isolating specific circuits in the JTA that were suspect. Sandia accepted these findings, had additional testing performed on the suspected circuits, and was able to isolate the specific failure mode.

Similar test environment capabilities exist in all of our weapon system laboratories. For example, the E-3 Airborne Warning and Control System (AWACS) laboratory has both surveillance radar configurations; this way, all versions of the E-3 software can be tested. During Desert Shield/Desert Storm, an enhancement was required to support that effort. The requirement was identified on Thursday. The change was programmed, implemented, tested in the laboratory, flight tested at Tinker AFB, and sent to the theatre on a resupply flight the next Monday. This demonstrated the fast turnaround capabilities of organic resources with high fidelity test environments.

This system has also helped with software not developed by our organization.

During the early 1980s, the AWACS wing experienced a serious problem with the E-3 navigational computer system. The system consistently failed to capture the turn portion of an established surveillance orbit, potentially causing the E-3 to fly into unauthorized airspace. Serious consequences were narrowly avoided on several occasions. Once notified of the problem, the E-3 AISF was able to reproduce the problem in the laboratory, locate the source in another organization's code, and develop a fix. The modified operational flight program was then tested in the E-3 AISF and delivered to the E-3 fleet in a timely manner.

These types of weapons system test environments are normally established as a part of the weapon system development program at the prime contractor's facility. The test equipment is then either duplicated at or transferred to a government facility for support of the weapon system software after deployment of the weapon system. Since the test environment includes the avionics suite, the cost is very high. In 1995, replacement cost estimates for the AISFs were as follows:

- B-1: \$171 million.
- B-52: \$54 million.
- Missiles: \$51 million.
- E-3: \$100 million.

Each AISF is unique and may have more than one hot mockup of the avionics. Simulation computers are typically Harris (now Concurrent) computers and use Fortran, C, or C++, as the source language(s) for the simulation software depending on the specific application. Our experience is that the high cost of these high fidelity test environments is well worth the investment because they enable the software support activity to provide the customer and the warfighter with the required capabilities when they are needed.

Collaboration

Another key element in fielding capabilities is teamwork between the program manager, system engineer, software developer, warfighter, and tester. The B-52 Mission Planning Software Section is one of our top success stories. This section has responsibility for development and sustainment of the B-52 mission planning software (B-52 Aircraft/Weapons/Electronics [A/W/E]) that runs on the Air Force mission support system (AFMSS). This system essentially automates the process that the flight crews previously performed manually – according to the Technical Orders (TOs), which are used as the basis for the software requirements. One of the most important keys to success is customer involvement. To ensure that the product produced meets the

user/customer requirements, the warfighters are involved in each phase throughout the development.

The B-52 A/W/E is one element of the complete mission planning environment, which is a combination of 35 different elements of software and 17 pieces of dedicated B-52 aircraft software, as shown in Figure 1 (see page 6); the Glossary defines the terms in the figure. These are developed by different agencies and contractors, and many serve multiple weapon systems. Integration of all of these applications on a single system to meet overall warfighter requirements is a significant part of our effort.

The main key to success in this area is the in-depth understanding of the entire environment, both hardware and software. The mission planning process is tested from beginning to end, including the production of all flight products. These products are taken through the final verification of actually loading them in our B-52 AISF and flying the missions, complete with weapons, and the recording of all the data for analysis.

Ensuring success begins with customer or user relationships. More than a third of our key people who develop and maintain mission planning applications are on a first-name basis with dozens of stakeholders:

- **B-52 System Program Office.** All mission planning system engineers, program managers, and weapon system integration engineers communicate several times a week.
 - **46th Operations Group/Test Squadron.** Responsible Test Organization for mission planning; participates in our development test (DT), DT/operational test (OT), and formal qualification test (FQT).
 - **28th Test Squadron.** Final test authority for force development evaluation (FDE).
 - **Air Force Operational Test and Evaluation Center (AFOTEC) Detachment 2.** Official OT agency for mission planning.
 - **AFOTEC Detachment 5.** Official OT agency for weapon systems like the Cruise Missiles and Joint Air to Surface Stand-off Missile (JASSM).
 - **49th Flight Test Squadron.** B-52 Flight Test Squadron at Barksdale AFB.
 - **5th Operational Support Squadron.** Warfighters from Minot AFB.
 - **2nd Operational Support Squadron.** Warfighters from Barksdale AFB.
 - **Mission Planning System Support Facility.** Air Force mission planning software integration, distribution, and support from Hill AFB.
- As noted above, throughout the applica-

Glossary

A/W/E	Aircraft/Weapons/Electronics	FQT	Formal Qualification Test
ACM	Advanced Cruise Missile	ICD	Interface Control Document
AFMSS	Air Force Mission Support System	ICSMS	Integrated Conventional Stores Management System
AFOTEC	Air Force Operational Test and Evaluation Center	IDD	Interface Definition Document
AFPD	Air Force Policy Directive	INTEL	Intelligence Data
AGM	Air-to-Ground Missile	JASSM	Joint Air-to-Surface Standoff Missile
AISF	Avionics Integrated Support Facility	JDAM	Joint Direct Attack Munitions
ALCM	Air Launched Cruise Missile	JSOW	Joint Standoff Weapon
AMI	Avionics Midlife Improvement	JTA	Joint Test Assembly
AWACS	Airborne Warning and Control System	OAS	Offensive Avionics System
CALCM	Conventional Air Launched Cruise Missile	OT	Operational Test
CALCM C/D	Two versions of the CALCM	PFPS	Personal Flight Planning System
CLOAR	Common Low Observability Auto Router	SRAM	Short Range Attack Missile
DAFIF	Digital Aeronautical Flight Information File	SEPG	Software Engineering Process Group
DDLC	Digital Data Loader Cartridge	SMXG	Software Maintenance Group
DT	Development Test	SWPS	Strategic War Planning System
DTC	Data Transfer Cartridge	TO	Technical Order
DTUC	Data Transfer Unit Cartridge	TBMCS	Theater Battle Management Core System
FDE	Force Development Evaluation	U2A	U.S. Strategic Command to AFMSS
FPM	Flight Performance Model	WCMD	Wind Corrected Munitions Dispenser

tion's life cycle the stakeholders meet frequently via face-to-face meetings and teleconferences. At least once a year, a mission planning open house is conducted at the user's base of operations. This includes several days for familiarization with our existing applications and user interface working group meetings to discuss upcoming designs, priorities, trade-offs, and requirements. Our engineers and computer scientists also hit the road, spending an average of more than 200 man-days per year in the field, meeting with the users, other develop-

ers, and other program offices to continually coordinate efforts, schedules, and requirements, and to provide familiarization with our systems.

Requirements review boards for our A/W/E applications and AFMSS core are conducted and defect review boards are held following each formal test. Eight official test events were hosted last year. Each event had one or more users or customers working side-by-side with the developers. As part of the development effort, several DTs are hosted prior to the FQT. At least one of

these DT tests will be a combined DT/OT that is a development test using operational procedures, data, and crew members, making it as real-world as possible. This process is a profound strength in the organization. Feedback is received from the users continually throughout the development phase.

The OT certification brief is prepared and presented. Using Air Force Manual 63-119, Certification of System Readiness for Dedicated Operational Test and Evaluation, a matrix of 33 certification templates is evaluated that identifies specific problem or risk areas that could hinder the smooth transition from development, through test, to the fielding of a product. All of the communities listed above participate in this process, and the entire group agrees that the product is ready to be tested. This final step provides complete confidence that the products will meet the warfighter's expectations the first time, every time. When a product approaches fielding certification, the actual users have seen it, used it, evaluated it, tested it, and stand behind it along with the developers.

A recent success story centers around a flight performance change to the way mission planners need to account for drag on the B-52 because of external weapons hanging on the wings. The multiple weapon configurations create different fuel burn rates affecting the range of the aircraft. Implementing this change in the TO spanned three software releases and required participation from almost every organization listed above.

Through requirements review, software development, integration, test, and the

Figure 1: B-52 Mission Planning Environment

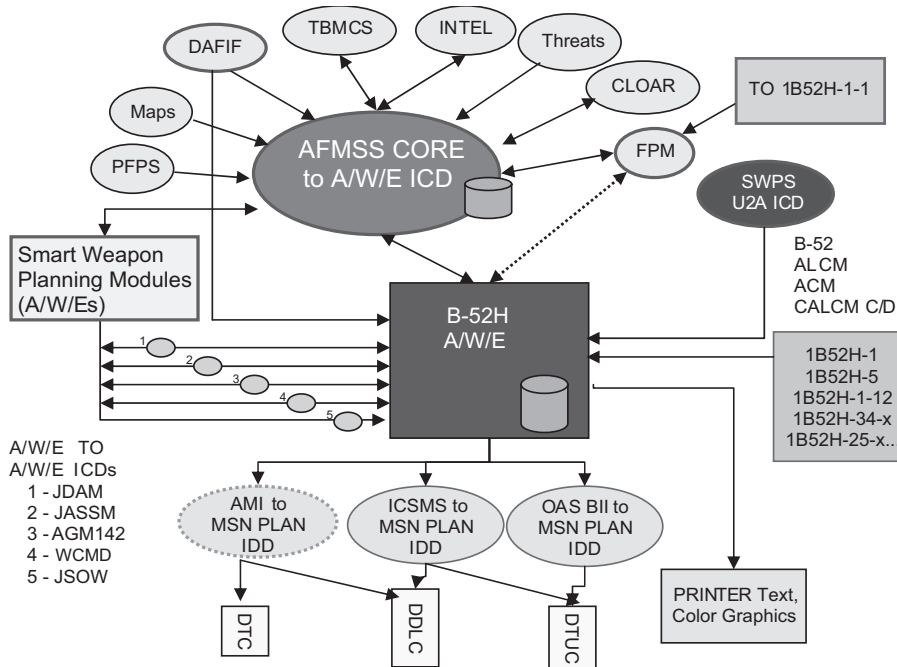

defect review board process, each spiral would further refine the requirements, each time giving the user increased capabilities and enhancing the system effectiveness to plan aircraft missions. It became clear early when dealing with this issue that each member of the team had a different piece of the puzzle. Only through continuous communication and collaboration were the answers to all the questions understood enough to produce a quality tool for the warfighter.

From start to finish, nothing is done in a vacuum without the user. A lot of companies will offer the user an early look or attendance at design reviews, but the customer seldom gets the complete picture or real hands-on experience during development of its system. As explained here, Tinker AFB's B-52 mission planning section goes above and beyond to get the user involved in every step. Nothing is hidden or kept from the customer. By involving the users in requirements reviews, early DT events, and using our integrated suite of test facilities, the customer is allowed to actually run the system end-to-end in one location. A demonstration of one or two isolated pieces of the puzzle is not needed because the user sees the whole enterprise and walks away with a feeling of confidence that what is paid for will provide the capabilities required in the field.

This type of team effort is becoming more important with the Air Force Policy Directive (AFPD) 63-1 cited commander's intent that states, "The primary mission of

our acquisition system is to rapidly deliver to the warfighter affordable, sustainable capability that meets their expectations." The objective of AFPD 63-1 is to "create a context that allows the program manager to shape and execute a program with an emphasis on teamwork, trust, common sense, and agility." It further states that "the warfighters, developers/acquirers, technologists, testers, budgeters, sustainers, and industry must plan and execute together in order to meet the Commander's intent." These seem to be lofty ideals, but we have proven they can be done.

Summary

Fielding capabilities can be enhanced by having high fidelity test environments and by collaboration between all of the participants on a program. The Air Logistics Centers at Robins AFB and Hill AFB have similar capabilities to those that are described in this article, although for different weapon systems. Program managers may be able to take advantage of existing organic resources to reduce cost and risk. Further, partnering agreements can be established between organic software support activities and contractors to facilitate utilization of organic resources in teaming arrangements to work jointly on Department of Defense projects. All three Air Logistic Center software support activities have Web sites (see page 30) that provide contacts. ♦

About the Authors



John D. Holcomb is the Operational Flight Programs technical expert in the 76th Software Maintenance Group at the Oklahoma City-Air Logistics Center, Tinker Air Force Base, Okla. He has 40 years of federal service, including 33 years of experience in weapon systems software, and participated in the development of the Department of Defense Standard 2167. He has a bachelor's degree in math and physics (double major) from the University of Central Oklahoma.

76th SMXG
4750 Staff DR
Tinker AFB, OK 73145-3318
Phone: (405) 736-3835
Fax: (405) 736-3584
E-mail: john.holcomb@tinker.af.mil



Michael Hoehn currently manages the B-52 Mission Planning Software Section in the 76th Software Maintenance Group at Tinker Air Force Base, Okla. He has more than 15 years experience in both Test Program Set and Operational Flight Program software development and maintenance.

76th SMXG
8080 Perimeter RD STE 107
Tinker AFB, OK 73145
Phone: (405) 736-5539
Fax: (405) 736-4129
E-mail: michael.hoehn@tinker.af.mil

COMING EVENTS

September 12-16

Practical Software Quality and Testing Conference 2005 North
 Minneapolis, MN
www.psqtconference.com/2005north

September 18-23

International Function Point Users Group 1st Annual International Software Measurement and Analysis Conference
 New Orleans, LA
www.ifpug.org/conferences/annual.htm

September 19-22

Better Software Conference and Expo 2005
 San Francisco, CA
www.sqe.com/bettersoftwareconf

September 26-27

PDF Conference and Expo
 Washington, DC
www.pdfconference.com

October 16-20

Object-Oriented Programming, Systems, Languages, and Applications Conference
 San Diego, CA
www.oopsla.org/2005/ShowPage.do?id=Home

October 17-20

MILCOM 2005
Military Communication Conference
 Atlantic City, NJ
www.milcom.org/2005

October 17-21

Quality Assurance Institute's 26th Annual Software Testing Conference
 Orlando, FL
www.qaiusa.com

May 1-4, 2006

2006 Systems and Software Technology Conference



Salt Lake City, UT
www.stc-online.org