

# Measuring Urban Communications

William Rasmussen, Conrad Welch, Janet McDonald, Thomas Colegrove \*

## Introduction

Military operations in urban terrain (MOUT) increasingly become the common form of engagement in various conflicts around the world. Effective communications are critical. Emergency and safety response groups also require reliable communications in these settings. At the same time, the amount of urban communications required in our cities continues to increase and its quality is important to the users and thus to the system providers. The degree and severity of the interactions of the communications signals with the materials comprising the urban environment varies greatly. Knowing and predicting these interactions and how to adjust for them increases the quality of the communications. Optimal transmitter power, the minimal number and locations of repeater equipment, areas of poor communications, as well as the suggested use of certain communications frequencies and/or communications equipment can be determined from such analyses.

## Electromagnetic signal interactions

The electromagnetic waves which comprise communications signals interact with nearly everything in the environment. These interactions are often described by the processes of reflection, diffraction, refraction, absorption, and re-radiation. For simple situations, such as no buildings present or only one wall, they can be predicted quite well. It is much more difficult to achieve this predictive power for communications quality as the complexity of the environment and situation increases. This is the case for urban situations having many buildings or within a large building. In these complex situations one often finds that their cell phone works well in one place but there is a problem just a few inches away, which illustrates the rapid spatial variation in signal strength indicative of fast fading. Causes of these variations include the composition and positioning of the building materials, ductwork and wiring, furniture and other items in the buildings, relative position of the buildings, traffic on the street, vegetation, and numerous other things.

## Communications modeling

The effects of interactions of the electromagnetic waves within such environments can be and have been modeled with various programs such as physics-based EMTerrano, by EMAG Technologies, or the empirical Okamura-Hata equations. In order to know where these models work well and where there may be problems, they need to be checked against actual measured urban communications data. The following describes the activities and results of an AMSAA funded project conducted by the U.S. Army Electronic Proving Ground for collecting communications data within as well as

\* / NewTec, NewTec, EPG and AMSAA

# Report Documentation Page

Form Approved  
OMB No. 0704-0188

Public reporting burden for the collection of information is estimated to average 1 hour per response, including the time for reviewing instructions, searching existing data sources, gathering and maintaining the data needed, and completing and reviewing the collection of information. Send comments regarding this burden estimate or any other aspect of this collection of information, including suggestions for reducing this burden, to Washington Headquarters Services, Directorate for Information Operations and Reports, 1215 Jefferson Davis Highway, Suite 1204, Arlington VA 22202-4302. Respondents should be aware that notwithstanding any other provision of law, no person shall be subject to a penalty for failing to comply with a collection of information if it does not display a currently valid OMB control number.

1. REPORT DATE <b>2005</b>		2. REPORT TYPE		3. DATES COVERED <b>00-00-2005 to 00-00-2005</b>	
4. TITLE AND SUBTITLE <b>Measuring Urban Communications</b>				5a. CONTRACT NUMBER	
				5b. GRANT NUMBER	
				5c. PROGRAM ELEMENT NUMBER	
6. AUTHOR(S)				5d. PROJECT NUMBER	
				5e. TASK NUMBER	
				5f. WORK UNIT NUMBER	
7. PERFORMING ORGANIZATION NAME(S) AND ADDRESS(ES) <b>Electronic Proving Ground,ATTN: CSTE-DTC-EP-TT,2000 Arizona Street,Fort Huachuca,AZ,85613-7063</b>				8. PERFORMING ORGANIZATION REPORT NUMBER	
9. SPONSORING/MONITORING AGENCY NAME(S) AND ADDRESS(ES)				10. SPONSOR/MONITOR'S ACRONYM(S)	
				11. SPONSOR/MONITOR'S REPORT NUMBER(S)	
12. DISTRIBUTION/AVAILABILITY STATEMENT <b>Approved for public release; distribution unlimited</b>					
13. SUPPLEMENTARY NOTES <b>Modeling and Simulation Conference, 2005 Dec 12-15, Las Cruces, NM</b>					
14. ABSTRACT					
15. SUBJECT TERMS					
16. SECURITY CLASSIFICATION OF:			17. LIMITATION OF ABSTRACT	18. NUMBER OF PAGES	19a. NAME OF RESPONSIBLE PERSON
a. REPORT <b>unclassified</b>	b. ABSTRACT <b>unclassified</b>	c. THIS PAGE <b>unclassified</b>			

outside various building configurations. Communications measurements were collected within wooden, poured concrete, and brick-concrete-and-steel buildings. They were also collected on the streets of a metropolitan city (Rosslyn, VA) and along the sidewalks and streets of a large university (University of Arizona). Detailed terrain data were collected as well as three-dimensional descriptions of all buildings. The Rosslyn site used the two frequencies of 49.95 and 413.35 MHz while the Arizona sites used the four frequencies of 49.425, 379.6, 943.5 and 1842 MHz. This effort adds to a previous received signal measurement study for the Rosslyn area at 900 and 1900 MHz(1).

### Equipment

The transmitter site equipment was comprised of a communications transmitter, amplifier, power meter, spectrum analyzer, and appropriate antennas. The power meter gave the power radiated and the spectrum analyzer monitored the frequency and strength of the radiated signal. The equipment was mainly powered from a wall outlet except for street measurements in Rosslyn when they were powered by power inverters attached to several outlets in the transmitter vehicle (Figure 1).



Figure 1. Transmitter site at ground level on University of Arizona site.

The equipment at the receiver site was a spectrum analyzer, computer, GPS or laser distance measuring device, several appropriate antennas, power inverter, and an auto battery with recharging equipment. For building measurements, the equipment was carried on an equipment cart that was changed to a jogging stroller as the project

continued (Figures 2 and 3). The receiver site was in a vehicle for the Rosslyn area with power for the inverter from the power outlets in the vehicle (Figure 4).



Figure 2. Receiver equipment on equipment cart.



Figure 3. Receiver equipment on jogging stroller.



Figure 4. Receiver vehicle used in Rosslyn.

## Locations and building constructions

### Arizona – Wooden building

The wooden building used in the study was constructed in the 1880s. It is nearly all wood with wooden support beams, steps, walls, floors and roof. It has been remodeled many times. The cooling system comes from a unit to the west of the building, through a 5 by 4 foot duct into the basement. Air is then brought up with a large duct in the center of the building to the levels above. There is considerable ductwork carrying air from the central duct to the various parts of the building. The roof area is insulated and appears to have foil-lined insulation tacked to the inside of the pitched roof. There is a small basement with two full floors above that. Both the main floor and top floor have long exterior porches along the full length of the east and west sides of the building. The floor plans for the three floors of the building were used for positioning within the building.

### Arizona – Concrete building

The concrete building is mainly constructed of steel and concrete. It has concrete flooring and concrete exterior walls. There are concrete and steel pillars supporting the building. The interior walls are often constructed from wood studs and plasterboard. It is three stories high with the basement covered by ground in the front. The basement is at the level of the surrounding ground in the rear.

### University of Arizona

The university began in the 1880s and has experienced continual growth in the number of buildings since then. The buildings are mostly three to five stories high. They have mostly been built using a steel framework and pre-stressed concrete for flooring. The exterior walls vary. Some use wall studs and plasterboard with others concrete or cinder block. Nearly all of the buildings have a brick exterior. The interior wall partitions range from wood studs and plaster board, to wood studs and stucco, or concrete in some cases.

The measured building is roughly 30 years old. It was built with a steel framework and concrete flooring. The exterior walls are sometimes cinder block or concrete. In all cases there is a brick exterior layer. The interior walls are wooden studs with plasterboard. In some cases they are comprised of studs with stucco on a wire mesh. The building has extensive ductwork for A/C and heating. Many of the central ducts run along the middle of the hall ceilings. There are a number of large walk-in freezers and refrigerators throughout the building. It has a full basement, one floor below ground level, and five floors above giving it six operational floors.

#### Rosslyn – Group of buildings

The Rosslyn area is comprised of mainly multi-story (4-15 story) buildings. They are largely steel and concrete construction with various types of outside surface coverings. It is representative of a modern high-rise urban area.

#### Data collection

#### Arizona – Wooden building

Figure 5 shows the measurement locations superimposed on an overhead two-dimensional representation of the wooden building. Figure 6 presents one of the 3D measurement paths plotted within the building wire frame model. In addition, as with the other sites, the two locations of the transmitters used for the measurements in and about the building as well as the four frequencies used are presented in the measurements file. There is a name for each transmitter-frequency location; it is also on one of the tabs in the main path loss data file containing the collected data. The equipment table also presents the power out of the amplifier and the total of the losses and gains of the transmitter and receiver systems.

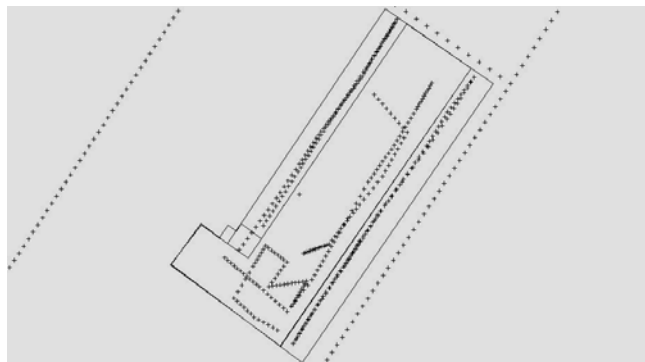

Figure 5. Receiver points plotted on the wire frame wooden building.

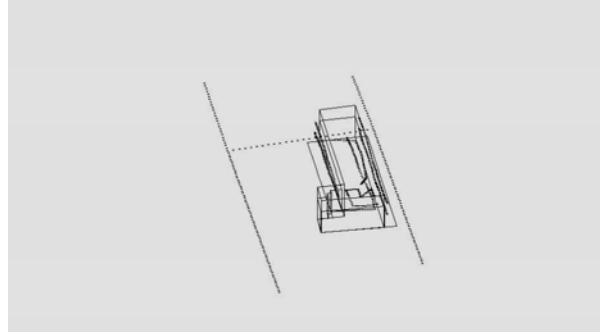

Figure 6. Perspective plot of the measured values plotted on and about the wooden building for a typical transmitter–frequency combination.

The main path loss data file contains the path loss data for locations in and about the wooden building using the 8 transmitter–frequency combinations. The file is broken into measurement paths, determined by use of the laser distance measuring device, the names of which are given on the tabs in the file. The transmitter locations are also given on another tab. Again, the main data file presents the latitude, longitude, and elevation of the receiver referenced to the WGS 84 spheroid model and datum, along with the path loss associated with that transmitter–receiver combination. In addition there is a time and date that the measurement was taken.

As with the University of Arizona and other sites, each path loss value presented in the main data file is based on the average signal level from 400 individual signal strength values received at the front port of the spectrum analyzer and stored. The detailed signal strength data are also provided in a folder. The detailed signal strength information stored in this file is related to the main path loss data by the time stamp. All of the wooden building data were collected when the receiver was in motion. The detailed data gives the received signal strength at 400 successive small distance intervals, collected over a 700 mS time interval, along the measurement path.

#### Arizona – Concrete building

The concrete building is a large concrete and steel building comprised of three halls. Floor plans of the three floors of the concrete building and a laser distance measuring device were used for locating the receiver within the building. A wire frame model of the concrete building is presented in Figure 7. Each of the eight measurement paths are plotted on the 3D wire frame model of the building. In addition, as with the other sites, there is a file that presents the two locations of the transmitters used for the measurements in and about the concrete building as well as the four frequencies used. There is a name for each transmitter–frequency location and that is on one of the tabs in the main path loss data file containing the measured values. The equipment table also presents the power out of the amplifier and the total of the losses and gains of the transmitter and receiver systems.

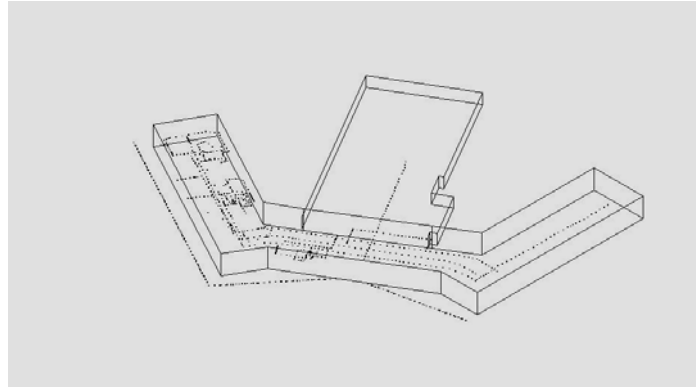

Figure 7. Concrete building wire frame model with measured value paths plotted within it.

The main path loss data file (Figure 8) contains the path loss data for locations in and about the concrete building using the 8 transmitter-frequency combinations. The file is broken into measurement paths, the names of which are given on the tabs in the file. The transmitter locations are also given on another tab. Again, the main data file presents the latitude, longitude, and elevation of the receiver along with the path loss associated with that transmitter-receiver combination. In addition there is a time and date that the measurement was taken.

	A	B	C	D	E	F	G	H	I
	Latitude	Longitude	Elevation (m)	PathLoss(dB)	Time	Date			
2	32.23049011	-110.9517365	743.72	-68.85	10:17:09	6/26/2003			
3	32.23048782	-110.9517059	743.73	-72.68	10:17:13	6/26/2003			
4	32.23048782	-110.9516754	743.74	-70.68	10:17:17	6/26/2003			
5	32.23048782	-110.9516449	743.76	-69.37	10:17:21	6/26/2003			
6	32.2304863	-110.9516251	743.77	-87.02	10:17:24	6/26/2003			
7	32.23048401	-110.9515991	743.78	-64.85	10:17:28	6/26/2003			
8	32.23048401	-110.9515686	743.79	-88.37	10:17:32	6/26/2003			
9	32.23048401	-110.9515381	743.81	-68.77	10:17:36	6/26/2003			
10	32.23048401	-110.9515076	743.82	-62.88	10:17:40	6/26/2003			
11	32.23048248	-110.9514801	743.83	-60.47	10:17:44	6/26/2003			
12	32.23048019	-110.9514542	743.84	-61.00	10:17:48	6/26/2003			
13	32.23048019	-110.9514236	743.86	-60.28	10:17:52	6/26/2003			
14	32.23048019	-110.9513931	743.87	-58.94	10:17:56	6/26/2003			
15	32.23048019	-110.9513626	743.88	-62.94	10:18:00	6/26/2003			
16	32.23047943	-110.9513412	743.89	-58.16	10:18:03	6/26/2003			
17	32.23047638	-110.9513168	743.90	-61.10	10:18:07	6/26/2003			
18	32.23047638	-110.9512863	743.92	-62.10	10:18:11	6/26/2003			
19	32.23047638	-110.9512558	743.93	-64.89	10:18:15	6/26/2003			
20	32.23047485	-110.9512253	743.94	-64.81	10:18:19	6/26/2003			
21	32.23047256	-110.9511963	743.96	-73.12	10:18:23	6/26/2003			
22	32.23047256	-110.9511719	743.97	-69.77	10:18:27	6/26/2003			

Figure 8. Measured values using the 943 MHz frequency.

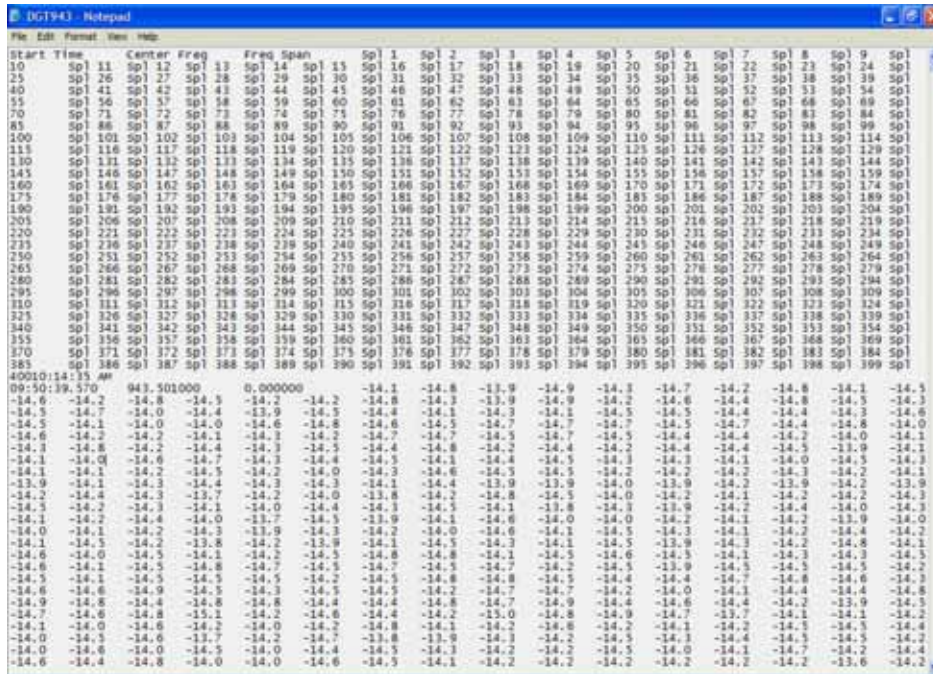

Figure 9. Typical detailed measurement values. There are 399 measured values captured for each value plotted on the path maps.

Again, as with the University of Arizona data, each path loss value presented in the main data file is the average signal level from 400 individual signal strength values received at the front port of the spectrum analyzer. The detailed signal strength data are collected and provided in a folder. The detailed signal strength information stored in this file is related to the main path loss data by the time stamp (Figure 9). All of the Arizona data were collected when the receiver was in motion.

### University of Arizona

Figures 10 and 11 present several views around the University of Arizona campus. Blueprints of the measured building were used with the laser distance measuring device for positioning within the building. Figure 12 presents a wire frame model of the measured building and Figure 13 presents wire frame models of all the University buildings in the study area.



Figure 10. View from the roof of Shantz looking northwest.



Figure 11. View from roof of Shantz looking northwest.

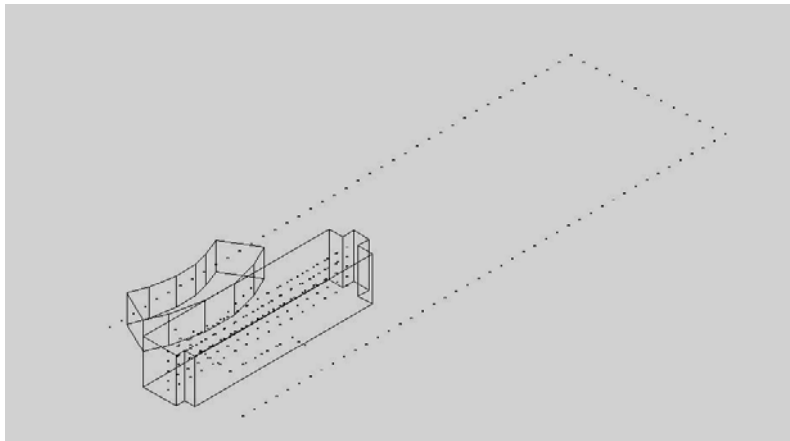

Figure 12. Perspective view of the measurement points within and outside the measured building for a specific transmitter location-frequency combination.

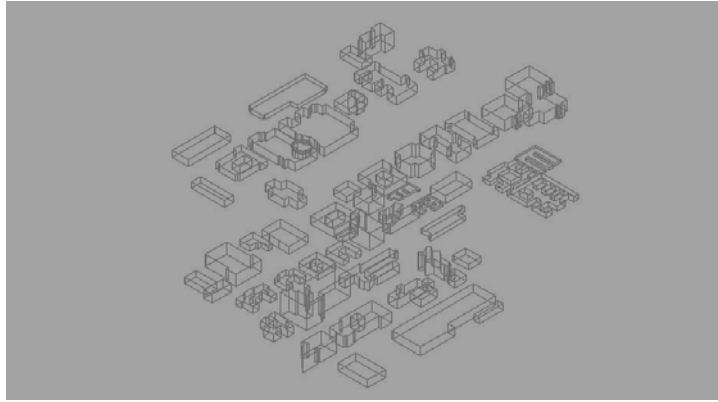

Figure 13. Frame models of all the U of A buildings near the measurement paths.

Again a file was developed that contains descriptions of the frequencies used and the names assigned to the 24 transmitter-frequency combinations. There were six transmitter sites. The locations of the transmitters are given in latitude, longitude, and elevation. The signal power out of the amplifier as well as losses and gains of the systems are also provided in this file.

The main data file contains the path loss data for locations about campus using all the 24 transmitter-frequency combinations. The file is broken into measurement paths, the names of which are given on the tabs in the file. The transmitter locations are also given on another tab. Figures 14 and 15 present the location of the measurement path for one of the 24 traverses of the campus. The main data file presents the latitude, longitude, and elevation of the receiver along with the path loss associated with that transmitter-receiver combination. In addition there is a time and date that the measurement was taken.



Figure 14. Typical measurement path through the University of Arizona campus for a specific transmitter location-frequency combination.



Figure 15. Typical measurement path through the University of Arizona campus for a specific transmitter location-frequency combination.

Each path loss value presented in the main data file is based on the average signal level from 400 individual signal strength values received at the front port of the spectrum analyzer. The detailed signal strength information is related to the main path loss data by the time stamps. All of the Tucson data, in the buildings and around the campus, were collected when the receiver was in motion. The detailed data gives the received signal strength at 400 successive small distance intervals along the measurement path. The spectrum analyzer takes roughly 0.7 seconds to record the 400 points and then approximately 2 seconds to analyze, display and store the information before another stream of 400 points are measured. This causes a detailed measurement of the received signal for a distance along the ground then a gap of about three times this length while the spectrum analyzer is processing data before it collects another strip.

The main data file also contains interior and exterior measurements for the five story measured building. Detailed signal strength measurements are also provided for these path loss measurements.

To help better understand the setting, pictures of all the buildings along the measurement paths were collected. These can be used to see the structure and surface materials on the buildings. Two are provided in Figures 16 and 17.



Figure 16. Marley building



Figure 17. Education building.

## Rosslyn

In Rosslyn, VA, the data collected were from outside measurements at the two frequencies of 49.95 and 413.35 MHz. Five transmitter sites were selected and measured signal levels collected on the surrounding streets. Path loss values are presented for all the measurement collection paths. A GPS device gave position information.



Figure 18. View along one of the streets in Rosslyn.

Figures 18 presents an urban view of Rosslyn.

As at the other sites, a database contains all the data for Rosslyn. The transmitter locations, their names and frequencies are given under the Transmitter tab in the spreadsheet. The other tabs present the path loss, location, and elevation data for each frequency-transmitter location combination. Equipment information including combined losses and gains are also enclosed. Figure 19 presents one of the data collection paths.



Figure 19. Collection path through Rosslyn.

#### Measurement coordinates and WGS 84 spheroid coordinates

Several methodologies were used to transfer the coordinates of the measurement points to the maps of the building or maps of the area and then to the WGS 84 spheroid model. Within and outside the buildings the measurement points were noted relative to the building plans. These were then transformed to maps of the area with numerous control points. These, in turn, were then transformed to spheroid model coordinates. Outside measurement points were made using a GPS and then adjusted to maps of the area, when needed. Relative positions of the measurement paths with the buildings were maintained in all coordinate transformations. Numerous control points on the location maps of the city or campus were then mapped to the WGS 84 spheroid model. Using these key point transformations the rest of the measurement points were transformed to the spheroid

coordinates. Again the relative positions of the measurement points and the buildings are maintained in the final spheroid coordinates.

### Typical Data

Figures 20 – 22 present typical normalized signal strength or negative path loss values for paths within and around the buildings. The position axis is the measurement point number relative to the start of measurements and NOT distance from the transmitter. The values will shift strongly when going from one floor to another. They are presented to show the variations within reaches of signal measurements (along a hall or around a room).

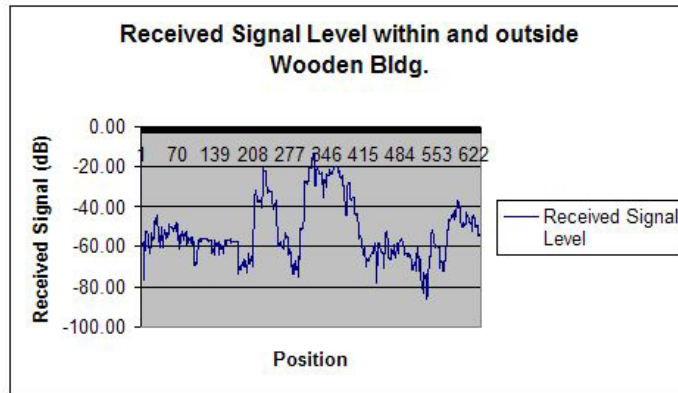

Figure 20. Normalized received signal level (negative path loss) in dB within and outside the Arizona wooden building. The top floor transmitter operated at 49 MHz.

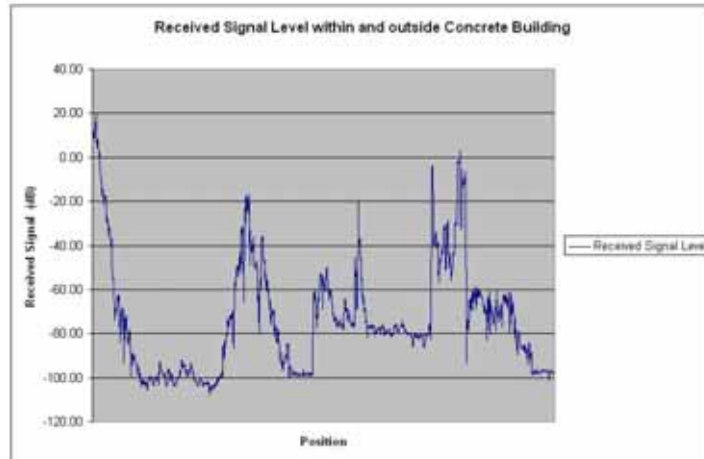

Figure 21. Normalized received signal level (negative path loss) in dB within and outside the concrete building. The transmitter was on the top floor and operating at 49 MHz.

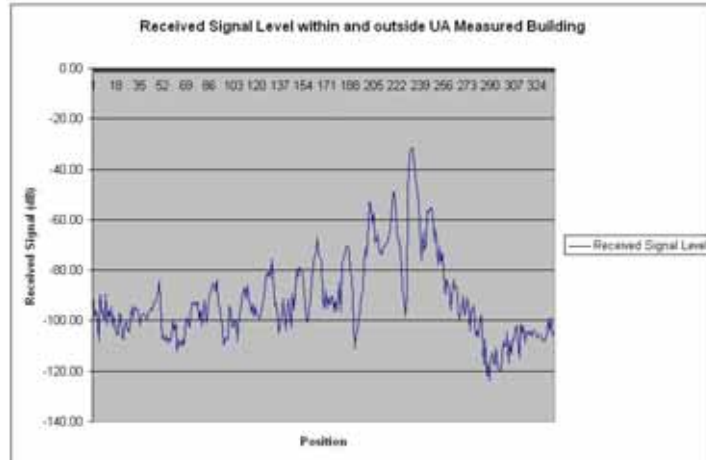

Figure 22. Normalized received signal level (negative path loss) in dB within and outside the measured building at the University of Arizona. The transmitter was on the ground floor and operating at 49 MHz.

Figures 23 through 27 present variations in normalized received signal strength (negative path loss) in traversing paths around the University of Arizona and around Rosslyn, VA. Again, the position axis is the measurement point number relative to the start of measurements and NOT distance from the transmitter. The values will shift on the circuitous paths driving around the city and walking around the campus. They are presented to show the variations within a given contiguous path reach (driving away from the transmitter or towards it).

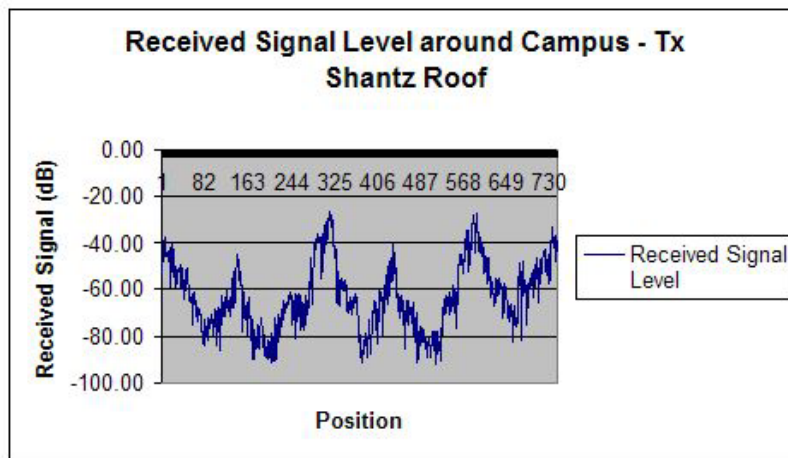

Figure 23. Normalized received signal level (negative path loss) in dB in a path around campus when the transmitter was on the south side of the Shantz roof and operating at 49 MHz.

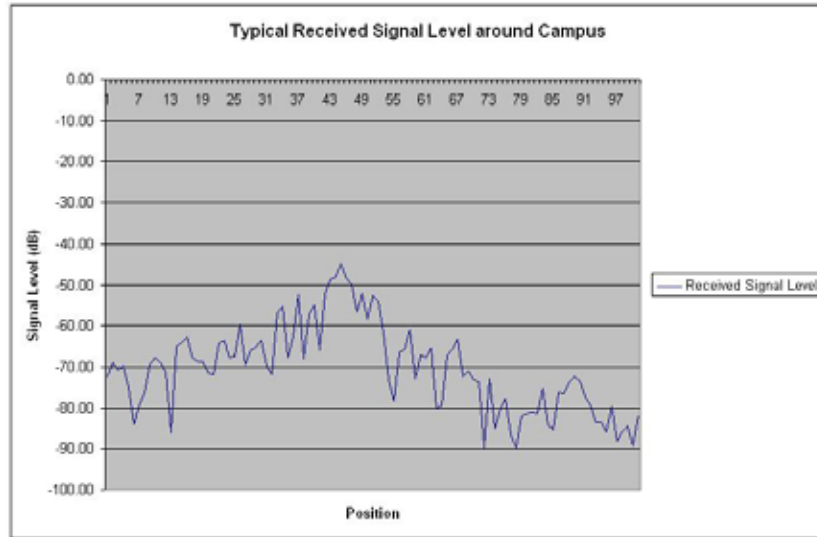

Figure 24. One hundred consecutive measured values on a path around campus using 49 MHz.

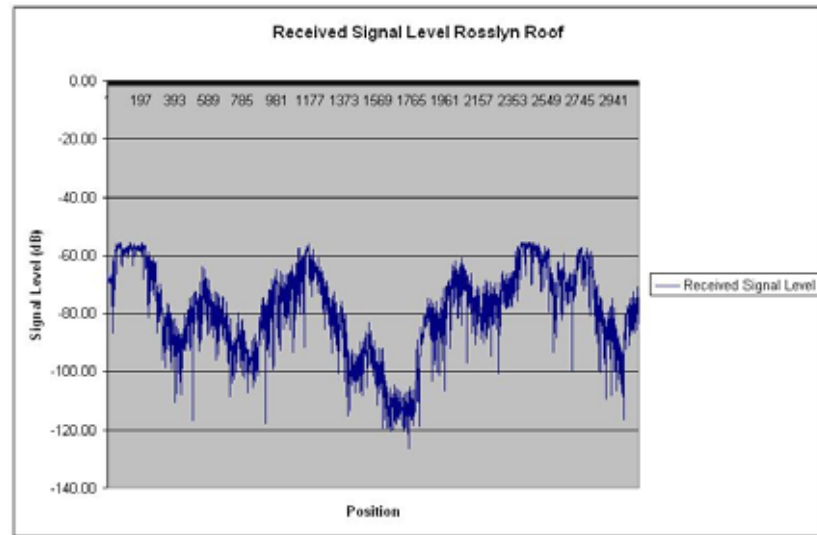

Figure 25. Normalized received signal level (negative path loss) in dB in a path around Rosslyn when the transmitter was on a roof and operating at 413 MHz.

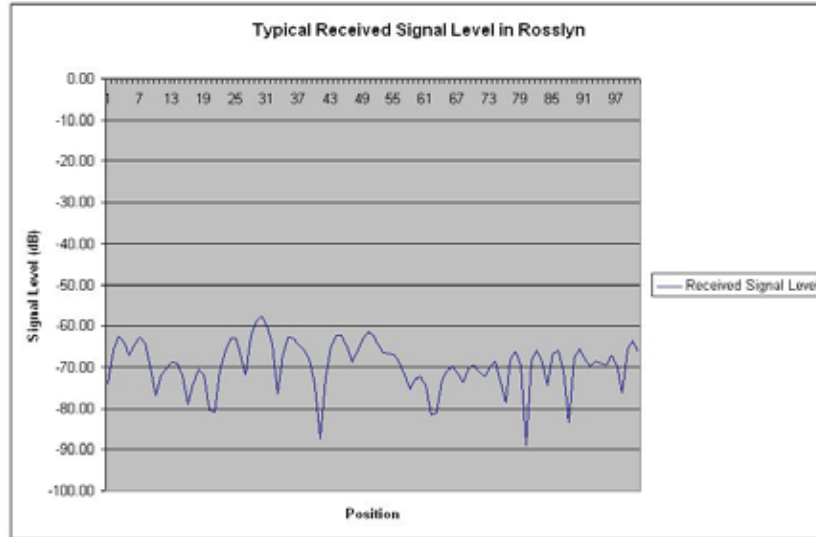

Figure 26. One hundred consecutive measured values on a path around Rosslyn at 49 MHz..

### Summary

The project resulted in the collection of signal propagation data within and around three types of buildings. There were four frequencies used and two transmitter sites in each building. In addition, outside propagation measurements were conducted for transmitters at four locations in the University of Arizona complex, also at four frequencies. Additional propagation measurements were made for two frequencies within the Rosslyn metropolitan area for transmitters at five sites. All the data were converted to path loss values. Three dimensional location coordinates were associated with all measurement points. Building heights were measured and used with building shape information (from maps, blueprints and aerial photos) at the University of Arizona and other Arizona sites to construct three dimensional models of buildings in the study area. The 3D locations of measurement points within these buildings were shown on the three dimensional models of the buildings.

### Contact Person/Questions

The EPG Director of the MOUT data collection effort is Janet McDonald. She can be reached by telephone at (520) 538-4958; FAX (520) 538-4973, DSN 879-4958. Her E-mail address is [Janet.McDonald@EPG.ARMY.MIL](mailto:Janet.McDonald@EPG.ARMY.MIL). The mailing address is: Electronic Proving Ground, 2000 Arizona Street, ATTN: CSTE-DTC-EP-TT, Fort Huachuca, AZ 85613-7063. Assisting her on the project were William Rasmussen, Conrad Welch, Barry Miller, Juan Escobar and Richard Kuhlman.

## References

1. T.M. Willia, B.J. Guarino, J.D. Moore, R. Luebbers, J. Schuster, H.L. Bertoni, G. Liang, N. Wo, UHF and Microwave Propagation Prediction in an Urban Environment, Paper presented at the NATO AGARD Sensor and Propagation Panel Meeting, Athens, Greece, September 18-21, 1995. Included in AGARD Conference Proceedings CP-547, Digital Communications Systems: Propagation Effects, Technical Solutions, Systems Design, pp 8-1 to 8-12, April, 1996.