

UNCLASSIFIED

AD NUMBER

ADA491810

CLASSIFICATION CHANGES

TO: UNCLASSIFIED

FROM: CONFIDENTIAL

LIMITATION CHANGES

TO:
Approved for public release; distribution is unlimited. Document partially illegible.

FROM:
Distribution authorized to DoD only; Foreign Government Information; JUN 1952. Other requests shall be referred to British Embassy, 3100 Massachusetts Avenue, NW, Washington, DC 20008. Document partially illegible.

AUTHORITY

DSTL ltr dtd 16 Feb 2007; DSTL ltr dtd 16 Feb 2007

THIS PAGE IS UNCLASSIFIED

~~CONFIDENTIAL~~

ROYAL AIRCRAFT ESTABLISHMENT

FARNBOROUGH, HANTS

TECHNICAL NOTE No: G.W.200

DEVELOPMENT OF PYROTECHNIC IGNITERS FOR A 6 in. RAMJET

by

K.H.PORTER

1. THIS INFORMATION IS DISCLOSED FOR OFFICIAL USE BY THE RECIPIENT GOVERNMENT. DISCLOSURE TO ANY OTHER GOVERNMENT OR RELEASE TO THE PRESS OR IN ANY OTHER WAY WOULD BE A BREACH OF THIS CONDITION.
2. THE INFORMATION SHOULD BE SAFEGUARDED UNDER RULES DESIGNED TO GIVE THE SAME STANDARD OF SECURITY AS THAT MAINTAINED BY HIS MAJESTY'S GOVERNMENT IN THE UNITED KINGDOM.
3. THE INFORMATION CONTAINED IN THIS REPORT SHOULD NOT BE CIRCULATED OUTSIDE GOVERNMENT DEPARTMENTS WITHOUT THE PRIOR PERMISSION OF THE MINISTRY OF SUPPLY.

OIN 5283

INV. 90

PICATINNY ARSENAL LIBRARY
DOVER, N. J.

MINISTRY OF SUPPLY

THIS DOCUMENT IS THE PROPERTY OF H.M. GOVERNMENT AND ATTENTION IS CALLED TO THE PENALTIES ATTACHING TO ANY INFRINGEMENT OF THE OFFICIAL SECRETS ACT, 1911-1939.

It is intended for the use of the recipient only, and for communication to such officers under him as may require to be acquainted with its contents in the course of their duties. The officers exercising this power of communication are responsible that such information is imparted with due caution and reserve. Any person other than the authorised holder, upon obtaining possession of this document, by finding or otherwise, should forward it, together with his name and address, in a closed envelope to:-

THE SECRETARY, MINISTRY OF SUPPLY, MILLBANK, LONDON, S.W.1.

Letter postage need not be prepaid, other postage will be refunded. All persons are hereby warned that the unauthorised retention or destruction of this document is an offence against the Official Secrets Act.

RECEIVED
19 SEP 1957
ORDGIA

Handwritten notes: "mail # 1", "ORD-LIBART-46", "113", "018713"

20081208284

U.D.C. No. 621.43.04 : 621.454.019

Technical Note No. G.W.200

June, 1952.

ROYAL AIRCRAFT ESTABLISHMENT, FARNBOROUGH

Development of Pyrotechnic Igniters for a 6 in. Ramjet

by

K. H. Porter

R.A.E. Ref: GW/S/144/8/139

SUMMARY

Tests have been made to develop a suitable pyrotechnic igniter for the Reid air blast burner 6 in. ramjet. Two types of igniter have been successfully developed, one flash type and one long burning type. The modifications necessary to adopt standard pyrotechnic practice to fulfil the exacting requirements of ramjet ignition are described.

LIST OF CONTENTS

	<u>Page</u>
1 Introduction	4
2 Requirements for Ramjet Ignition	4
2.2 Ignition in Flight	4
2.3 Ignition on the Test Bed	5
3 Preliminary Bench Tests	5
4 S.R. 580A 10 sec. Tracking Flare	6
4.1 Construction	6
4.2 Ignition Tests	7
5 S.R. 306 8 sec. Igniter	8
5.1 Construction	8
5.2 Ignition Tests	9
6 S.R. 306 R.A.E. Flash Igniter, types F.1 and F.2	9
6.1 Construction	9
6.2 Ignition Tests	9
7 S.R. 306 R.A.E. Flash Igniter, Type 4	10
7.1 Construction	10
7.2 Proof Tests	10
7.3 Ignition Tests	11
8 S.R. 306 R.A.E. Flash Igniter, Types F.6 and F.7	12
8.1 Construction	12
8.2 Ignition Tests	12
9 Low Tension Fuses	13
10 S.R. 105 10 sec. Igniter, Type A.R.E. 7	13
10.1 Construction	13
10.2 Ignition Tests	14
11 S.R. 105 13 sec. Igniter, Type A.R.E. 10	14
11.1 Construction	14
11.2 Ignition Tests	14
11.3 Improved Type A.R.E. 10	14
12 Miscellaneous Tests	15
13 Pyrotechnic Compositions	16
14 Conclusions	16
References	17
Advance Distribution	17

TABLE

Details of Ramjet Igniters Tested	<u>Page</u> 18-19
-----------------------------------	----------------------

LIST OF ILLUSTRATIONS

	<u>Fig.</u>
Ramjet combustion chamber showing positions in which igniters have been tested.	1
SR.580A. 10 sec. standard tracking flare and details of modifications	2
Early stages of burning of a standard 10 sec. tracking flare	3
" " " " " " Modified 10 sec. tracking flare	4
Section through a cardboard lined flare	5
Section through an unlined steel case flare	6
Section through SR.306 - 8 sec. igniter showing fault which can cause a 'blind'	7
Experimental SR.306 ('Cendite') fuse	8
Burning of F.7 type igniters in ramjet flame holding cone (As fitted in JTV test vehicle)	9
Details of ramjet 'flash' igniters	10
Showing burning of type F.7 igniter	11
Incomplete combustion of charge when bursting pressure of cap is considerably reduced (cap not secured) Type F.7 igniter	12
'Flash' type igniter fired under 30g showing burn through of case	13
Type F.7 igniter	14
Comparison of Chlorate and Cerium Low Tension Fuses (Close up view)	15
Comparison of peak flame Chlorate and Cerium Low Tension fuses	16
Construction of low tension fuse	17
Ignition of Compressed SR.306 by Cerium Low Tension Fuse without primer	18
Details of improved type A.R.E.10 igniter	19

1 Introduction

1.1 A ramjet depends upon its forward speed for the compression of the air burnt within it and, in consequence, for the propulsion of a test vehicle or weapon, it will normally only be used when acceleration to supersonic velocities is achieved by other means. Under these conditions the ramjet is preferably ignited as soon as the forward speed is sufficient for combustion to be maintained. A flame, a spark or other source of high temperature gas or particles is required to initiate combustion in the ramjet. When the ramjet fuel is a liquid hydrocarbon, pyrotechnics have been generally used for ignition because of the high heat release available and the ease with which they can be installed and operated.

1.2 This report describes the development of several types of pyrotechnic igniters undertaken for the 6 in. Reid air blast burner ramjets, fitted to the J.T.V. test vehicles in which aviation Kerosene is used as a fuel.

2 Requirements for Ramjet Ignition

2.1 On a ramjet, combustion is often maintained by providing a baffle stabilized, fuel fed, pilot flame; in this case a short duration pyrotechnic flare may be used for ignition. An alternative sometimes employed is to use a continuously burning pyrotechnic flare, to pilot the main combustion. Thus the general problem of ramjet ignition is either to light the pilot flame by a small pyrotechnic or to provide a continuously burning flare. The conditions under which either type of pyrotechnic must function are similar.

2.2 Ignition in Flight

2.21 In flight, the test vehicle or weapon will be accelerated longitudinally at some 30g from a launching platform and later in the flight, possibly during ignition, the acceleration normal to the axis may be as high as 15g. Vibration may be present. The fuel-air mixture passing over the pyrotechnic before combustion is established will be in a highly turbulent state and at a temperature of perhaps 1200°C.

2.22 For a weapon it is desirable to ignite the ramjets as soon as the forward velocity is sufficient for the thrust to be appreciable in order to reduce the total impulse necessary for acceleration. In addition a smoother start may be achieved if the ramjets are lit as soon as combustion is possible.

2.23 A typical procedure for starting up a fuel piloted ramjet is to start the fuel supply and fire the pyrotechnic igniter as the vehicle is launched, then ignition should take place as soon as the fuel-air mixture is within the stability or inflammatory limits. Some combustion chambers will not light at subsonic speeds and others will not burn around sonic speeds ($M = 1$) because the temperature and pressure of the air in the combustion chamber are low and the velocity in comparison is high. Until combustion is established the velocity of the air through the ramjet is much higher than when it is burning normally and in some cases, to ease the ignition conditions, the ramjet is fitted with a restrictor in the tail pipe to reduce the exit area; the restrictor is either burnt out when combustion is established, or removed by some other means.

2.24 A pyrotechnic fired at launch, for a fuel piloted combustion chamber, must continue burning until the weapon or test vehicle reaches a Mach number at which stable combustion is possible and it may be desirable for it to continue burning until the launching acceleration is completed if the fuel control system is affected by g, or is not very rapid in response. An alternative procedure is to fire a short duration

or "flash type" pyrotechnic igniter at the instant after launching when the conditions for ignition are correct. For flash ignition it is thought likely that a far higher rate of heat release than for an igniter of longer duration is required to establish conditions similar to those when the ramjet is burning and so stabilize combustion instantaneously.

2.3 Ignition on the Test Bed

2.31 It is not usually possible on the test bed to simulate the changes in air temperature and flow through the ramjet that occur during the high acceleration. The procedure frequently adopted is to carry out ignition tests at spot points. This is most conveniently done by adjusting the air and fuel flows to the appropriate values and then firing the pyrotechnic igniter. The igniter must therefore be capable of withstanding the test conditions for several minutes although in flight these conditions are only transitory.

2.32 To operate satisfactorily under both bench and flight conditions igniters must:-

- (i) be proofed against fuel at the operating temperature, which in this case is around 120°C for say 5 minutes.
- (ii) withstand some 30g in any direction.
- (iii) withstand the vibration which is expected.
- (iv) be reliable and consistent in performance.
- (v) take a minimum electrical current.

3 Preliminary Bench Tests

3.1 The 6 in. ramjet in which the tests were conducted is fuel piloted. It is fully described in a previous report¹ but a diagram of the combustion chamber is given in Fig.1 which shows the arrangement of the primary and main air blast fuel jets and cone shaped stabilizer or flame holder.

3.2 In early bench tests, ignition was effected by a train of electric sparks from a booster coil. The ramjet was lit at a very low subsonic air velocity and this was gradually increased until the desired supersonic test condition was reached. This method was satisfactory on a coupled rig but under free jet test conditions, it was extremely difficult to raise the airspeed of the free jet stream up to supersonic without extinguishing the ramjet.

3.3 For ignition tests this method was not satisfactory, because the flight conditions of acceleration to supersonic speeds could not be simulated and the spot method, using a steady fuel flow at the available Mach number of 1.35 was adopted. All attempts to light the combustion chamber with a 24 volt booster coil were unsuccessful, so some tests were carried out with pyrotechnic igniters containing a standard incendiary composition, SR.306. These tests indicated that this method could be satisfactorily developed for this type of combustion chamber.

3.4 Only a limited number of ignition tests could, at this time, be completed as the plant was due for overhaul. The thermal requirements for ramjet ignition could not be ascertained but the indications were that, with the pyrotechnic compositions tested, a heat release of above 2,000 cal/sec. was required and that the higher the heat release the more certainty there was of ignition.

3.5 For a 6 in. ramjet the space available for igniters is limited and the igniters must be of such a size and so positioned that the combustion is not adversely effected by their presence. As pyrotechnics are not normally 100% reliable in operation, duplication of igniters is generally desirable. For these reasons only a comparatively small igniter could be used and therefore a composition having a high heat release on a volume basis, was required.

3.6 The problem was discussed with pyrotechnic authorities and manufacturers, who advised that, if possible, standard pyrotechnic compositions should be used, thereby eliminating unknown factors in manufacture, safety, storage etc. It was decided that before experimental armament establishments or Royal Ordnance Factories could undertake igniter development, experiments were necessary to define the requirements more precisely. Two series of tests were therefore conducted in parallel, the first using SR.580 tracking flares, which are a standard store, and the second, special igniters containing the composition SR.306 previously tested, which could be made up by local manufacturers. Both compositions have a high heat release on a volume basis.

3.7 In the following descriptions of the igniters, various pyrotechnic compositions such as SR.580, SFG.12 etc. are mentioned. Detailed specifications of these compositions are obtainable from:-

The Chief Chemical Inspector,
Chemical Inspectorate,
Ministry of Supply,
Block A/4 Station Approach Buildings,
Kidbrook, S.E.3.

4 S.R.580A 10 sec. Tracking Flare

4.1 Construction

4.11 The SR.580A composition is a standard flare filling with a magnesium-sodium nitrate base, its heat release being 1700 cal/grm. and when compressed in the 10 sec. tracking flare has a density of 1.7 gm/cc. The construction and operation of this tracking flare follows standard pyrotechnic practice. The case and base are of mild steel and the SR.580 charge is filled in 5 increments each of which is inserted as loose powder and compressed into the case. The top increment includes the primer train of SR.252, SFG.12 and gunpowder cambric which is fired by a low tension LMNR/chlorate, sulphur shrouded, fuse. The fuse is crimped into a copper fuse tube soldered into the closure cap, which is a push fit into the steel case, (see Fig.2).

4.12 Initial tests of these flares proved this form of ignition to be worth further investigation. As supplied these flares were not proof against hot kerosene and under test bench conditions the sulphur shroud of the fuse melted and permitted kerosene to enter and desensitize the fuse and primer. The high test rig temperature also causes the steel case to expand and the closure cap to become loose. As the metal cap is made of 30 s.w.g. (0.012 in.) tinsplate the fit is not closely controlled and some caps will not stand rough handling. To improve the proofing of the flare the sulphur shroud securing the fuse, was deleted and asbestos string substituted. The closure cap was made secure by peening over the case in four places, the cap and fuse tube then being sealed with cellulose acetate (see Fig.2). These modifications improved reliability on the test rig, but not to the standard required.

4.13 The primer used, forms gas on burning and, very occasionally, in normal use, the primer explodes rather than burns, with the result that the main charge does not ignite. It was found in further rig tests that such explosive 'blinds' were occurring frequently and this was attributed to the increased rate of burning resulting from the high temperature and the improved sealing of the closure cap.

4.14 High speed photographs of this type of flare, when fired under atmospheric conditions with zero air velocity, show that when the closure cap is expelled the low intensity initiating flame of the primer is exposed and that the intensity of the flame fades before the charge commences to burn (see Fig.3). It is considered that the flare could be easily extinguished by the high velocity fuel-air stream at these early stages of burning. These tests indicated that either a gasless or a comparatively slow burning primer was required if the igniter was to be proofed against fuel and to work at high temperatures; in addition either the primer flame must be sufficiently robust to withstand exposure or the cap must remain in place and burn through when the main charge has commenced to burn (see Fig.4 for desired characteristics of burning).

4.15 Upon occasions an SR.580A flare would fail to burn across an increment joint. This was considered to be due to the expansion of the steel case which reduces the adhesion of the increments as the heat of combustion of the flare advances through the charge and when combined with the vibration of the ramjet, the increment breaks away leaving the remainder of the charge unburnt, "blind". Frequently during ignition tests, large pieces of burning charge could be seen passing out of the ramjet tail pipe, such pieces considerably reduce the total burning time of the flare. To increase the strength of the increment joints the top of each increment is always roughened to key it to the next, but it is not possible to produce a bond as strong as the individual increments. Figs. 5, 6 and 7 show the section through three types of flare igniter, it will be noticed that there is a change in the homogeneous packing of the charge at the joint of the increment.

4.16 To assist in retaining increments on large diameter pyrotechnics the cases are often lined with cardboard. This enables the compacting pressure through the increments to form indentations in the cardboard liner, so keying the charge to the liner and reducing the heat flow to the casing, (see Fig.5). The small diameter of the SR.580A 10 sec. tracking flare made the incorporation of a cardboard liner difficult.

4.2 Ignition Tests

4.21 Ignition tests were made on a free jet rig², usually at a simulated flight speed of $M = 1.35$ and air fuel ratios of 9:1 to 15:1. The igniter or flare to be tested was inserted into the combustion chamber, the air speed and temperature worked up to the conditions required, the fuel turned 'on' and adjusted to the required flow, when all conditions were correct the flare was fired. This method imposed a severe test on the proofing and construction of the flares, as the time taken to reach spot conditions varied from 3 to 5 min.

4.22 The SR.580A flares were tested in pairs as duplication was desirable to achieve sufficient reliability, and were mounted in various positions, (see Fig.1). Ignition of the ramjet was not obtained at $M = 1.35$ but did occur at $M = 0.7$. A tail pipe restrictor which reduced the cross sectional area by 20% was tried and the ramjet lit at $M = 0.7$ and $M = 1.35$ but at these conditions combustion at ignition was very unstable and there was a 4 to 5 sec. ignition delay after the flares had been fired.

4.23 Using a 25% venturi shaped restrictor in the tail pipe and two SR.580 tracking flares positioned as at 'C' (see Fig.1) the Bristol Aeroplane Co. were able to obtain satisfactory ignition during bench tests of a 6 in. Reid air blast burner ramjet at $M = 1.3$. This arrangement of flares was therefore tried in flight in the J.T.V. test vehicle, the flares being fired 3 sec. before launch to enable the combustion of the flare to be well established before flight commenced. However, the combustion during ignition was unstable, as it was on the R.A.E. free jet rig.

4.24 As it was not found possible to establish stable combustion when using this type of igniter, further development at this stage was abandoned. Later, during the development of other igniters a new low tension fuse was found that would ignite SR.580 and SR.580A without primers (see Paras. 9.6 and 12.1 Fig.4). This arrangement, which is now being used on SR.580 tracking flares with great success, led to the development of a larger diameter cardboard lined SR.580 igniter, tests of which are described in Para.12.5.

5 S.R.306 8 sec. Igniter

5.1 Construction

5.11 This igniter was produced in parallel with, and as an alternative to, the SR.580A 10 sec. flare, and had approximately the same heat release per sec., (see Table). The SR.306 composition is a standard incendiary mixture known as 'Cendite', containing aluminium, barium nitrate and hammer scale (Fe_3O_4). This mixture when compressed is one of the more difficult compositions to ignite and a number of primer trains were tried. The igniter case was of aluminium $\frac{3}{4}$ o/d \times $2\frac{1}{4}$ in. long and the mild steel base was a press fit in the case and secured by a cannellure. The charge of 26.4 grms. was filled in three increments, ignition was by means of a low tension LMNR/chlorate, sulphur shrouded fuse through the primer train. The fuse was crimped into a copper fuse tube soldered into the closure cap which was a push fit into the aluminium case. This arrangement of fuse and closure cap was altered in a similar manner as was the SR.580 tracking flare, to improve the proofing against fuel (see Fig.7).

5.12 The first primer train tried was SFG and SR.252 pressed into the bottom of a well formed in the top increment. The sides of the well sometimes collapsed and masked the primer, causing "blinds". The primer train ultimately adopted was the same as that employed in the 4 lb. Mk.IV incendiary bomb and consisted of gunpowder cambric, SR.252 and SFG.12 pressed with the top increment of 50% SR.306 and 50% SR.252. This arrangement was more robust but reduced the main charge burning time from 8 to 5 sec.

5.13 The total burning time of these igniters, when burnt in the ramjet, varied considerably and often the igniter would 'blind' at an increment as the case burnt away with the charge. Fig. 7 shows a fault in the top increment which can contribute towards a 'blind'. The 'blinding' at increments could have been reduced by fitting a cardboard liner but as in the case of the SR.580A tracking flare the diameter was too small for this to be done.

5.14 The first batch of 50 igniters incorporating the improved proofing and incendiary bomb primer were 100% reliable and enabled much test bench experience to be gained, but a number of a repeat order 'blinded' and others burnt erratically. Investigation and tests were made at the Contractor's works but the reason was not finally determined

and the performance of the first batch could not be reproduced. Sometime later, after further tests, it was concluded that this was due to variations in batches of SR.306, (see Para.6.11).

5.15 In an attempt to ignite compressed SR.306 without a primer, a wire bridge was compressed in with the top increment of the SR.306 charge but when the firing current was applied an explosion occurred which shattered the surrounding SR.306 and ignition failed. As an alternative a small wire bridge coated with a paste of SR.306 and nitro cellulose, to form a match (see Fig.8) was tried with success, but as some 20 amps was required to fire the match this means of ignition was not proceeded with (see Para. 9.6).

5.2 Ignition Tests

5.21 Igniters from the first batch made were tested on the free jet test rig² and when mounted in pairs in position A or B (see Fig.1) they would ignite the ramjet at $M = 1.35$, combustion being smooth and sustained. The ramjet lit as soon as the main composition in the igniter was burning, this occurred 3 sec. after the igniter had fired. Of the 10 igniters fitted to dummy J.T.V.I. Mk.V flight test vehicles, 9 burnt satisfactorily and 1 commenced to burn but failed at the second increment joint.

5.22 Later batches of igniters gave erratic results and a number of blinds occurred, in particular, igniters tested in flight in hot rounds of the J.T.V. test vehicle 'blinded' at increment joints. The development of this type of igniter was therefore discontinued.

6 S.R.306 R.A.E. Flash Igniter Types F.1 and F.2

6.1 Construction

6.11 During the development work conducted on the compressed SR.306 igniter, it was found that loose SR.306 could be ignited directly with a low tension LMNR/Chlorate fuse and this indicated the possibility of developing a flash type of igniter with a very high short duration heat release. Loose SR.306 burns very rapidly and if lightly contained is expelled as a burning cloud. Using this principle the first igniters were designed with 'blow off' metal caps. The specification for SR.306 (CS/940C) permits a wide range of sizes of 'blown' aluminium powder to be used. If uniform performance and easy ignition is to be achieved the sieve size of this powder must be closely controlled. With this in mind tests were made and a suitable combination of commercial aluminium powders selected. Details of the SR.306 used in the flash igniters is contained in the Table.

6.12 The igniter case was of aluminium $\frac{3}{4}$ in. o/d \times $2\frac{1}{4}$ in. long, the mild steel base was a press fit in the case and secured by a cannellure. The charge of 13.25 grms of loose SR.306 was packed in by vibrating the case, ignition was by means of a chlorate low tension fuse. In the first instance the sulphur shroud of the fuse was replaced by asbestos string and the fuse crimped into a copper fuse tube soldered into the closure cap which was a push fit into the aluminium case. To proof the igniter against fuel and moisture the closure cap and fuse tube was coated with cellulose acetate. This igniter was designated Type F.1.

6.2 Ignition Tests

6.21 To ensure reliability these igniters were used in pairs and mounted in position A, (see Fig.1). Tests on the free jet test rig² proved them to be reliable and worth further development. It was possible to light the ramjet over a range of air-fuel ratios, varying from 9:1 to 15:1, at a simulated airspeed of $M = 1.35$. In flight these igniters were

used in seven J.T.V.I. test vehicles and, as far as could be ascertained by examination upon recovery and a study of the high speed film, functioned correctly except in one instance when an electrical fault occurred. Ramjet ignition was only obtained in 5 instances but the failure could not be attributed to the performance of the igniters³.

6.22 It was found that the performance of the F.1 igniter was not entirely consistent unless the fit of the metal closure cap was closely controlled. This required selective assembly. When a cap was a tight fit a more violent explosion occurred and combustion of the charge was complete, but if a cap was a slack fit the explosion was of lower intensity and either the charge was incompletely burnt or it continued burning within the igniter case, (compare Figs. 11 and 12) which show the results of similar differences on a later mark of igniter. By positioning the fuse in the base of the case (Type F.2) complete expulsion of the charge was achieved, but no marked improvement in consistency of performance was obtained. Close control of the closure cap fit was still necessary.

6.23 In order to control the explosion pressure and thereby improve consistency of performance a small number of igniters were made with bursting discs in place of the usual press fit caps, the charge being fired by a fuse in the base. To enable the bursting disc to be fitted the diameter of the igniter was increased to 1 in. o/d; it was also thought that the heat gained, from this increase in capacity, would assist ignition of the ramjet under adverse conditions. From proof tests made it was found that a 0.003 in. thick soft copper disc gave sufficient control of the explosion to ensure efficient burning of the charge, whilst a 0.007 in. thick disc caused an explosion of such intensity that it would have damaged the burner. As a 0.003 in. disc is easily damaged and, because of its flexibility, difficult to proof against fuel or moisture; no actual ramjet ignition tests were conducted.

7 S.R.306 R.A.E. Flash Igniter, Type 4

7.1 Construction

7.11 This igniter was a development of the F.1 and 2 type igniters, and was designed to give increased heat release and improved reliability. The igniter was constructed with an aluminium case 1 in. o/d x 2 $\frac{1}{2}$ in. long and the mild steel base was pressed into the case and secured by a cannellure. This was the maximum size that could be used if two igniters were to be fitted in the flame stabilizing cone (see Fig.9). The charge of 32 grms. of loose SR.306 was vibrated into the case and fired by a low tension LMNR/chlorate fuse fitted into the base. Instead of the usual press fit metal closure cap or bursting disc this igniter was fitted with a Neoprene rubber bursting cap which was retained by a rubber bead and cannellure, the whole cap being finally secured by a wire lashing (see Fig.10).

7.2 Proof Tests

7.21 To check the functioning of this type of igniter proof tests were made and high speed photographs taken. Tests at atmospheric conditions proved the igniter to be very consistent in performance; it was estimated that over 95% of the SR.306 was always burnt, (see Fig.11). When comparing Figs. 9 and 11 it will be noticed that there is a 0.010 sec. variation in ignition delay between igniters of the same type. To simulate ramjet test bench conditions igniters were heated in kerosene at 120°C. for 5 min. and then fired. High speed photographs revealed that after heating at 120°C the burning time of the charge is reduced from 0.25 to 0.12 sec. with a corresponding decrease in ignition delay from 0.03 sec. to 0.018 sec. The hot kerosene caused a slight softening of the Neoprene cap which was responsible for some variation in performance. It was also found that it

was possible for the softened Neoprene to flow, when under pressure, from beneath the wire lashing and allow the cap to blow off at a lower pressure instead of bursting. When this occurs the combustion efficiency of the charge is lowered, (compare Figs. 11 and 12). To reduce the softening effect of the hot kerosene on the cap, a protective coating of Cellulose Acetate was applied; this was quite successful and increased the bursting pressure of the cap when hot from 50 to 60 p.s.i. Normal bursting pressure is 60 to 80 p.s.i. Apparently the accelerated burning of the charge when hot compensates for the lower bursting pressure of the cap. Before using this type of igniter for flight or bench tests it was subjected to vibration and g tests (see following paras.).

7.22 When g tested special attention was paid to the possibility of the charge being centrifuged onto or away from the fuse. The only slight malfunction observed during these tests was when 30g was applied normal to the axis. On one igniter, a small part of the charge was not expelled and burnt through the casing, (see Fig.13). The remaining 9 igniters tested at this condition did not burn through the casing, but there were indications that a very small amount of charge was 'hanging' to the wall of the cases. A further 10 igniters fired with 25g at this condition, functioned normally. During these tests not one igniter failed to burn satisfactorily.

7.23 Vibration tests (12-160 c.p.c., $\pm 10g$) were made through a range of amplitudes and frequencies with igniters mounted in various attitudes. The closure cap was removed from one igniter and the behaviour of the charge observed whilst passing through a wide range of amplitudes and frequencies. It was found that the charge behaved in one of two ways, it 'boiled up' or 'packed down'. Accordingly some igniters were vibrated for 10 min. at the frequency which produced the most pronounced 'boiling' and others at that giving greatest packing and then fired. Some of these were fired whilst vibrating. By visual observation no change in performance could be detected.

7.3 Ignition Tests

7.31 Bench tests of this type of igniter on the free jet rig² showed that using either one or two igniters, ramjet ignition was instantaneous at any condition within the range of air-fuel ratios 9:1/15:1 at a simulated air speed of $M = 1.35$.

7.32 The first two flight trials of this type of igniter were successful, both ramjets on each test vehicle lighting up and burning smoothly. Evidence after recovery revealed that all the igniters had functioned correctly. In later flight trials at a higher Mach number 6 igniter failures occurred. Examination of the defective igniters showed that, although the fuses had fired, there was no trace of the charge having burnt. As a check on the inflammability of the charge of such igniters, new fuses were fitted and the igniters rebuilt. None of these rebuilt igniters failed to burn.

7.33 In view of these unexplained failures repeat bench and proof tests were made and in addition a small batch of igniters subjected to extremes of temperature, -78°C to 140°C . Immediately after soaking for 5 min. at these temperatures the igniters were fired. In none of these tests did a failure occur.

7.34 As these tests did not reproduce a failure the functioning of the low tension LMNR/chlorate fuse was examined, (see Para.9.1). The tests indicated that the heat release varied appreciably and it is considered that a low heat release coupled with some vibration or g effect

might account for the flight failure. To improve reliability it was considered desirable to try a fuse with similar electrical requirements and a larger reserve of heat. It was discovered that Messrs. I.C.I. produce such a fuse, which is known as "gasless LMNR/Cerium fusehead (strengthened type)". These fuses were tested and found superior in every way, (see Para. 9.4 and igniters Types F.6 and F.7).

8 S.R.306, R.A.E. Flash Igniter Types F.6 and F.7

8.1 Construction

8.11 These igniters are of the same construction as the F.4 type except that the chlorate fuse is replaced by the gasless cerium fuse. In the type 6 igniter the fuse is assembled with a Neoprene plug which locates the fuse head $\frac{3}{4}$ in. from the bottom of the charge, (see Fig.10). During proof tests a small part of the charge was found in the bottom of two igniters and it was concluded and later proved, that as the fuse head was not right at the bottom, the charge was not completely expelled.

8.12 To ensure complete expulsion of the charge, the Neoprene plug was deleted and the fuse leads twisted and bent back to direct the fuse head at the base of the igniter, (see Fig.10). With this modification the type number was changed to 7. Extensive proof tests were conducted and the igniter proved to be satisfactory in every respect. Precise constructional details of this type of igniter are contained in Provisional Specification G.W.58.

8.2 Ignition Tests

8.21 At this time intensive ramjet ignition tests were being conducted on the 6 in. Reid air blast burner because of unexplained flight failures. For these tests the type F.7 igniter was used. It was found that the length of the pitot intake used in free jet tests had considerable effect on the ignition and the smoothness of combustion. With a short intake ($8\frac{1}{2}^{\circ}$ included angle) ignition and combustion characteristics varied with the change in vapour pressure of the different batches of aviation kerosene fuel used. When a longer intake (5° included angle) was fitted or a measuring section introduced behind the short intake, the ignition and combustion characteristics were not appreciably affected by changes in the vapour pressure of the fuel. With the long intake repeated tests showed that the ramjet could be lit with one or two F.7 igniters at any fuel flow within the stability limits of the burner.

8.22 For earlier free jet tests, a measuring section had usually been fitted behind a short intake, whilst in flight tests a short intake only was used. The use of a short intake has, undoubtedly, accounted for some of the failures of the ramjet to light in flight, but longer intakes were fitted on two test vehicles, with two F.7 flash igniters in each ramjet and again one ramjet of each vehicle failed to light. The reason for this failure is not understood.

8.23 Altogether more than 500 of these types of igniters have been manufactured and not one failure has occurred, although they have only been used with a Reid air blast burner in a 6 in. ramjet, it is thought that they may have wider application.

8.24 Fig.14 shows the finished igniter with storage plug fitted to base, this $\frac{1}{4}$ B.S.F. setbolt has to be removed before the igniter can be mounted. To protect the igniter against moisture during storage and the Neoprene cap against hot fuel, the whole igniter has been coated with Cellulose Acetate.

9 Low Tension Fuses

9.1 The unexplained failures of the R.A.E. Flash Igniter Type 4 when used in flight, (see Para. 7.32) placed suspicion on the consistency of performance of the low tension LMNR/chlorate fuse. For identification purposes the head of this fuse is coloured blue. To determine the cause of these failures the following tests were conducted.

9.2 Electrical tests in which the fuse head was gradually heated by slowly raising the firing current proved that slow heating of the fuse head had no deleterious effects. The fuse always fired satisfactorily before the minimum firing current of 0.4 amps was reached.

9.3 As a rough test on the consistency of performance, 50 fuses were proof fired and from observation there was considerable variation in the intensity and size of the flames. This test indicated that there was a possibility that the heat release from some of these fuses may be marginal for the ignition of SR.306 loose powder. To improve reliability it was considered necessary to obtain a fuse with a greater heat release and requiring the same firing current.

9.4 As the result of the writer's visit to Dr. W. Taylor of Messrs. I.C.I., who manufacture low tension fuses, a suitable production fuse was found; it is identified as "gasless LMNR/ceerium fuse (strengthened type)", the head of the fuse being coloured red.

9.5 Visual comparison and high speed photographs of these two types of fuse revealed that the chlorate fuse burns as a shower of relatively low temperature sparks, total burning time 0.070 sec. The ceerium fuse in comparison burns with a fast compact flame with some candescent fragments, total burning time 0.021 sec. Photographs comparing the burning of these two types of fuse and their construction are shown in Figs. 15, 16 and 17. For both types of fuse a minimum firing current of 0.6 amps is recommended. To assist in wiring and checking the firing circuit of the igniters the ceerium fuse was fitted with two different coloured firing leads. Other types of fuse requiring a comparatively higher firing current may be suitable, but as it was desired to make these igniters so that they could be fired either in flight or at launch a low tension fuse requiring a small firing current had to be used.

9.6 The superior heat release of the ceerium fuse was proved when a number of compressed ($2\frac{1}{2}$ ton/sq.in.) SR.306 igniters, each fitted with a single ceerium fuse and no primer, were fired without a failure (see Fig.18). The chlorate fuse will not ignite compressed SR.306 without a suitable primer train. As SR.580 is more readily ignited than SR.306, it was decided to remove the chlorate fuse and primer from 15 SR.580A 10 sec. tracking flares, to test the ignition of SR.580A using a ceerium fuse without primers. These tests were successful (see Para. 12.1).

10 S.R.105, 10 sec. Igniters, Type ARE.7

10.1 Construction

10.11 In view of the satisfactory ignition obtained with SR.105 on the 'Boeing' flare piloted burner at The Bristol Aeroplane Co., it was considered necessary to test this composition in igniters for the 6 in. ramjet. It was decided to try a single large diameter igniter as experience gained with ceerium fuses indicated the possibility of building igniters of such reliability that duplication was unnecessary. The large diameter would permit the use of a cardboard liner and other refinements which would contribute to reliability. A.R.E., Tandu, were requested to design and supply these igniters to a very brief R.A.E. specification.

10.12 The igniters supplied, were constructed with aluminium cases and bases, the cases being lined with 1/10 in. thick cardboard. The diameter was $1\frac{3}{4}$ in. and the length $2\frac{1}{2}$ in. The 80 grms. of SR.105 charge was filled and pressed in increments, the top and last increment followed by and pressed with the 12 grms. of magnesium-ferric oxide primer. The single gasless LMNR/cerium low tension fuse was located in a vee groove formed in the primer. the fuse leads passing out through a hole in the side of the case. To close the top of the igniter a 20 s.w.g. (0.036) aluminium disc was placed on top of the primer, the side of the case being pressed over to secure the disc. The disc and fuse lead entry were sealed with shellac. The total burning time was 10 sec.

10.2 Ignition Tests

10.21 Using one ARE.7 igniter mounted in the flame holding or stabilizing cone, position 'A' Fig.1, it was possible to obtain ignition and smooth, stable combustion at a simulated air speed of $M = 1.35$, at any point within the stability limits.

10.22 The reliability of these igniters was not satisfactory as the shellac proofing failed and the kerosene entered the igniter and desensitized the fuse. Of the 20 igniters tested, 3 failed due to explosive blinds, showing that a more reliable primer than $Mg Fe_2 O_3$, which also deteriorates in storage, was necessary. Flight tests were not conducted.

11 S.R.105, 13 sec. Igniter, Type A.R.E.10

11.1 Construction

11.11 Tests at the R.A.E. proved that a 5 gm. pellet of SR.580 pressed into a charge of SR.105 gave smooth 'take-over' and reliable ignition. The results of these tests were discussed with A.R.E., Tondu, who used SR.580 as a primer in the ARE.10 igniter. In this design the primer was 5 grms. of SR.580, filled loose and pressed in with the top increment. Two gasless LMNR/cerium low tension fuses fitted with rubber seals where the leads enter the case were used, the igniter being finally proofed with Cellulose Acetate. The length was increased to $2\frac{3}{4}$ in. and the compacting pressure raised to give a total burning time of 13 sec., which was desired for flight tests.

11.2 Ignition Tests

11.21 The ARE.10 igniter has been tested on the free jet ramjet test rig, using the spot method of testing as previously described, and in flight. Altogether 30 igniters have been fired without failure and no loss of charge has been observed. On the free jet rig the ramjet, as with the ARE.7 igniters, lit at all points within the stability range tried. The igniter has been used in two J.T.V. flight test vehicles and in the first both ramjets lit shortly after launch and continued burning until the vehicle broke up, while in the second vehicle one ramjet lit just after launch and the other at 'separation', both continued burning until the end of flight which occurred some seconds after the igniters had burnt out. The delayed ignition of one ramjet was caused by incorrect fuel flows during the launching acceleration. This igniter proved to be the best long burning igniter tried.

11.3 Improved Type A.R.E.10

11.31 An improved ARE.10 design has been passed to A.R.E., Tondu, for manufacture (see Fig.19). In this design the fuse leads are pressed between the cardboard liner and the aluminium case and will pass out through holes in the base. This arrangement protects the fuse leads against chafing and rough handling and will considerably improve the

proofing of the igniter against moisture and hot kerosene. To give a soft start and obviate the risk of 'explosive blinds' the design incorporates a thin aluminium bursting disc, 40 s.w.g. (0.0048) below which is placed a disc of steel gauze. The gauze, in addition to supporting the thin bursting disc permits any gases generated to pass and, should the primer shatter or be shattered it retains the burning pieces long enough to ensure ignition of the charge. When the charge commences to burn the gauze is burnt away. To prove this device conclusively, a large number of igniters with broken primers would be required, but five such igniters were manufactured and not one 'blind' occurred.

12 Miscellaneous Tests

12.1 To test the ignitability of SR.580A using a gasless LMNR/cerium fuse without primer, fifteen SR.580A 10 sec. tracking flares were modified. Removal of the primer and the elimination of all air space reduced the length of the flare by $\frac{1}{2}$ in. The fuse was located in the closure cap, which in turn was pressed on to the top of the charge and retained by crimping over the flare case in four places (see Fig.2).

12.2 Free jet rig ignition and proof tests demonstrated conclusively that, by deleting the gaseous primer and holding the closure cap in position until the main charge was burning, reliability of the flare was greatly improved. Ramjet ignition characteristics were unchanged, (see Para. 4.2). Figs. 3 and 4 compare the various stages of ignition of the modified and unmodified flares.

12.3 Being aware that difficulty was being experienced in igniting tracking flares at high altitudes, the results of the foregoing tests were passed to the flare manufacturers concerned. A large number of primerless SR.580 flares have since been manufactured and used without a single ignition failure.

12.4 When manufacturing an SR.580 store, which is to be fused direct with a cerium fuse, it is important that the store be allowed to stand for 48 hours before closing. This will enable the crust of Acaroid resin which forms on the top of the charge to be removed.

12.5 As it was proved that SR.580A could be reliably ignited without primers it was decided to ascertain the possibility of lighting the ramjet using an SR.580 igniter with a greater heat release per second than the SR.580A tracking flare. Two types were made, Type A had a heat release of 39,700 cal/sec. and was $1\frac{3}{4}$ in. dia. \times $2\frac{3}{4}$ in. long, Type B had a heat release of 17,000 cal/sec. and was $1\frac{1}{4}$ in. dia. \times $2\frac{3}{4}$ in. long, (for comparison see Table).

12.6 Ignition tests on the free jet rig were made and although both types would light the ramjet, combustion was very rough whilst the igniter was burning. Type B caused such rough combustion that further tests of this igniter were stopped to avoid damaging the burner. Tests using SR.580 were discontinued but in an attempt to learn more about the cause of rough combustion, three types of igniter were made at Tondu ARE.12, 15 and 16. The charge of these igniters was based on SR.580 but contained different weights of magnesium and were designed to give approximately the same heat release per second as the successful ARE.10 igniter (see Table).

12.7 When tested on the free jet rig Types ARE.12 and 16 gave explosive unstable burning for the duration of the igniter, combustion was not established. The Type ARE.15 igniter, which is rich in magnesium, showed no sign of lighting the ramjet whatsoever, not a spark or flame emerged from the ramjet tail pipe. When fired in still air the igniter burnt fiercely with showers of high velocity sparks.

12.8 It has since been learnt that SR.580 is considered to be a 'pulsating burner'. The different effect on ramjet combustion of the presence of sodium nitrate as compared with barium or strontium nitrate may be due either to the different breakdown of these oxygen carriers or to some catalytic effect.

12.9 Magnesium thermite was considered as a possible composition for an igniter. Two mixes were tried, one a straight forward thermite, ARE.13, and the other ARE.14, containing barium nitrate in addition. It was thought that tests of the two compositions would give some indication of the type of flame most suited to ramjet ignition. When proof tested the flame of the ARE.13 proved to be slow in developing and was smaller in comparison with the flame emitted by the ARE.14, which was similar to the ARE.10 (SR.105). On free jet test, ARE.13 and 14 gave an ignition delay of 2 - 7 sec., and 1 - 2 sec. respectively, ramjet combustion being smooth and stable over a wide range of air-fuel ratios at $M = 1.35$.

13 Pyrotechnic Compositions

13.1 There are undoubtedly a large number of factors governing the performance of a pyrotechnic composition as a ramjet igniter and the tests conducted have, of necessity, been far too limited for any definite conclusions to be reached, but the following observations are made.

13.2 The rate of heat release of the composition SR.580A required to light the 6 in. Reid air blast burner ramjet has been found to be in the neighbourhood of 10,000 cal/sec. while with the SR.306 composition, ignition was obtained with a heat release of 3,600 cal/sec. The lower heat release required with the aluminium based composition may be due to the higher maximum temperature possible (boiling point $Al_2O_3 = 3,000^\circ C$ $MgO = 2,800^\circ C$) or to the effect of the different oxygen carriers.

13.3 Of the successful igniters, those which contained a nitrate and produced a large voluminous flame gave more rapid ignition of the ramjet at supersonic conditions. The use of strontium or barium nitrate as an oxygen carrier gave better ignition and smoother ramjet combustion than sodium nitrate.

13.4 Extensive ramjet ignition tests were made with SR.105 and SR.306 in particular. Both compositions gave satisfactory ignition and smooth combustion and can be readily ignited with a cerium low tension fuse, SR.306 directly and SR.105 with a SR.580 primer. Because of its higher heat release, SR.306 may be more conveniently used where space limitations apply.

14 Conclusions

14.1 The pyrotechnic igniters described herein have been developed specifically for the Reid air blast burner 6 in. ramjet but the recommendations made as a result of these tests should apply to igniters for any other ramjet.

14.2 It is concluded that pyrotechnic igniters are a suitable form of ignition for ramjets and provided the recommendations made are followed, the high degree of reliability required can be obtained. Detailed designs for igniters which have proved successful are given.

14.3 The scope of the investigation being limited, only tentative recommendations can be made regarding the required characteristics of the pyrotechnic compositions for ramjet ignition. They are:-

- (a) A large volume of flame should be produced.

(b) The oxygen carrier should promote hydrocarbon combustion when decomposed.

(c) A high heat release is desirable.

14.4 Of the continuous burning igniters tested the ARE.10 type was the best. It is considered that a similar igniter using SR.306 instead of SR.105 would also give good results. The Type F.7 Flash Igniter has been extensively tested and proved entirely reliable.

14.5 No further work is contemplated.

REFERENCES

<u>Ref. No.</u>	<u>Author</u>	<u>Title</u>
1	J. Reid	The further development of a 6 in. dia. ramjet combustion chamber. R.A.E. Report G.W.12, dated February, 1952.
2	J. Reid and L. Fuller	Cold flow tests on a pitot diffuser at $M = 1.34$. R.A.E. Technical Note G.W.186.
3	R.W.L. Reed	A history of the J.T.V. Twin Ramjet Test Vehicle (To be issued shortly).

Attached:-

Table
Drgs. GW/P/3676 to 3679
Negs. 100442 to 100452

Advance Distribution:-

MOS Headquarters

Chief Scientist
CGWL
CS(A)
PDSR(A)
DGTD(A)
PDGW Action Copy + 65
DMARD
D Eng RD
AD Eng RD6
DMXRD
GWAB (Dr R.C. Knight)
TPA3/TIB 100

RAE

Director
DD(E)
DD(A)
RPD 3
Aero Dept 3
Arm Dept
GWTW 2
NGTE Pyestock 4
Library

Details of Ramjet Igniters Tested

Igniter Type	Total Burning Time Incl. Primer	Total Burning Time With Ramjet	Sec.	Weight of Charge	Density of Charge	Gr./cc	Calories per Gram of Charge in Still Air	Calories Released per Sec. in Still Air	Total Calories Released by Charge in Still Air	Ramjet Ignition Delay	Sec.	Details of Charge	Performance in Ramjet
SR. 580A. Tracking Flare	10	9	23	1.7	1700	4,000	39,000	4-5	Primer: Gun Powder Cambric and SR. 252 Weight 2gm. Charge: SR. 580A (Compressed) Magnesium Grade 0 60% Sodium Nitrate 36% Acetoid Resin 4%	Ignition not Sustained	Gave rough combustion, using two flares, ignition not sustained after flares burnt out (see Para. 4.2).		
SR. 306. Igniter	8	4-6	26	2.5	960	25,000	approx. burning time of primer and mixed increment 3 sec.	3	Primer: G/P Cambric, SR. 252 and SFG. 12 Weight 2 gm. Charge: SR. 306 (Compressed) Aluminum Powder 20% Barium Nitrate 35% Hammer Scale 40% Boric Acid 5% Top increment 50% SR. 306 and 50% SR. 252 mixed.	Gave smooth combustion but reliability poor (see Para. 5.2)			
SR. 306. R...E. Flash Igniter Types F.1 and F.2	<1	-	13	1.3 Dry	960	12,400	<0.1	Primer: None Charge: SR. 306. Powder (Special Grade) -300 Blown Aluminum Powder 10% -200 Flake " 10% Barium Nitrate 35% Hammer Scale 40% Boric Acid 5%	Gave smooth combustion but inconsistent performance (see Para. 6.2)				
SR. 306. R...E. Flash Igniter 0.25 Types F4, F6 and F7.	-	-	32	1.3 Dry	960	30,700	<0.1	Primer: None Charge: SR. 306. Powder (Special Grade) as F.1 and F.2 types	Latest Type F.7. gave smooth combustion, consistent and reliable performance (see Para. 8.2)				
SR. 105. Igniter. Type .RE.7	10	8	80	1.5	1400	112,000	<0.1	Primer: Magnesium-Ferric Oxide Mixture Weight 12 gm. Charge: SR. 105 (Compressed) Magnesium Grade V 5% Boiled linseed Oil 4% Strontium Nitrate 38% Polyvinyl Chloride 5%	Gave smooth combustion but poor reliability (see Para. 10.2)				
SR. 105. Igniter. Type .RE.10	13	11	95	1.5	1400	133,000	<0.1	Primer: SR. 580. Weight 5 gm. Charge: SR. 105 (Compressed). as .RE.7 Type	Gave smooth combustion, consistent performance and excellent reliability (see Para. 11.2)				

Continued Over

CONFIDENTIAL

Details of Ramjet Igniters Tested (Contd.)

Igniter Type	Total Burning Time Incl. Primer Sec.	Total Burning Time With Ramjet Sec.	Weight of Charge Grams	Density of Charge Gm/cc	Calories per Gm of Charge in Still Air	Total Calories Released By Charge in Still Air	Ramjet Ignition Delay Sec.	Details of Charge	Performance in Ramjet
Igniter Type ARE.12	10	8	105	- 1050	11,500	110,000	Unstable Ignition not Sustained	Primer: SR.580 Weight 5 gm. Charge: Magnesium Grade V 30% Acaroid Resin 4% Sodium Nitrate 66%	Explosions but no ignition, (See Para.12.7).
Igniter. Type ARE.16	5	4	36	- 1600	11,500	56,000	Unstable Ignition not Sustained	Primer: SR.580 Weight 3 gm. Charge: Magnesium Grade V 40% Lithographic Varnish 2% Sodium Nitrate 56%	Explosions but no ignition, (See Para. 12.7).
Igniter. Type ARE.15	5	-	23	- 2200	10,000	50,000	No Ignition	Primer: None Charge: Magnesium Grade V 66% Acaroid Resin 4% Sodium Nitrate 30%	No ignition whatsoever, (See Para. 12.7).
Igniter. Type ARE.13	8	5-7	165	- 860	18,000	142,000	2 to 7	Primer: SR.252 Weight 3 gm. Charge: Magnesium Grade V 30% Hammer Scale 70%	Smooth combustion but erratic burning of the igniter varying ignition delays and burning times, (See Para. 12.9).
Igniter. Type ARE.14	8	6	160	- 1000	21,000	160,000	1 to 2	Primer: SR.252 Weight 3 gm. Charge: Magnesium Grade V 20% Barium Nitrate 40% Hammer Scale 40%	Gave smooth and stable combustion, (See Para. 12.9).
SR.580. Igniter. Type A	4.5	3.3	105	1.5	1700	178,500	0.8	Primer: None Charge: SR.580 Magnesium Grade IV 60% Sodium Nitrate 36% Acaroid Resin 4%	Gave very rough combustion, (See Para. 12.6).
SR.580. Igniter. Type B	4.5	3.3	45	1.5	1700	76,500	1	is Type A	Gave such rough combustion that tests were discontinued to avoid damage to burner, (See Para. 12.6).

NOTE:- As it has not been possible to measure the exact burning time of the various primers when an igniter burns, and as the filling of commercially manufactured igniters is done by volume measurement, the heat release figures quoted for the above igniters must be considered as close approximations.

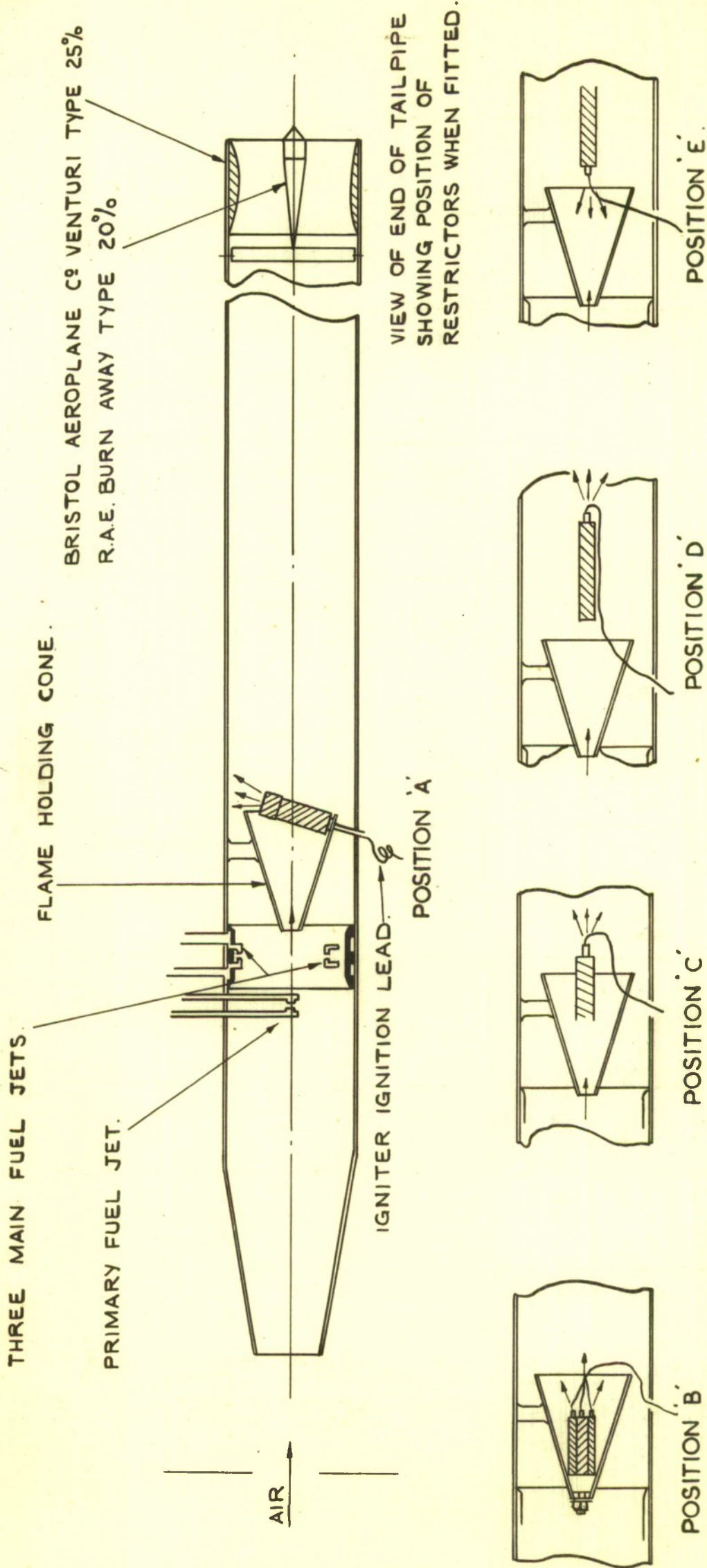
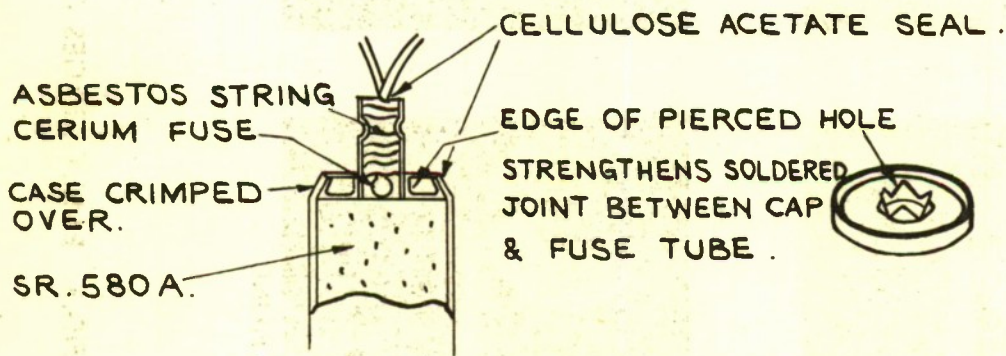
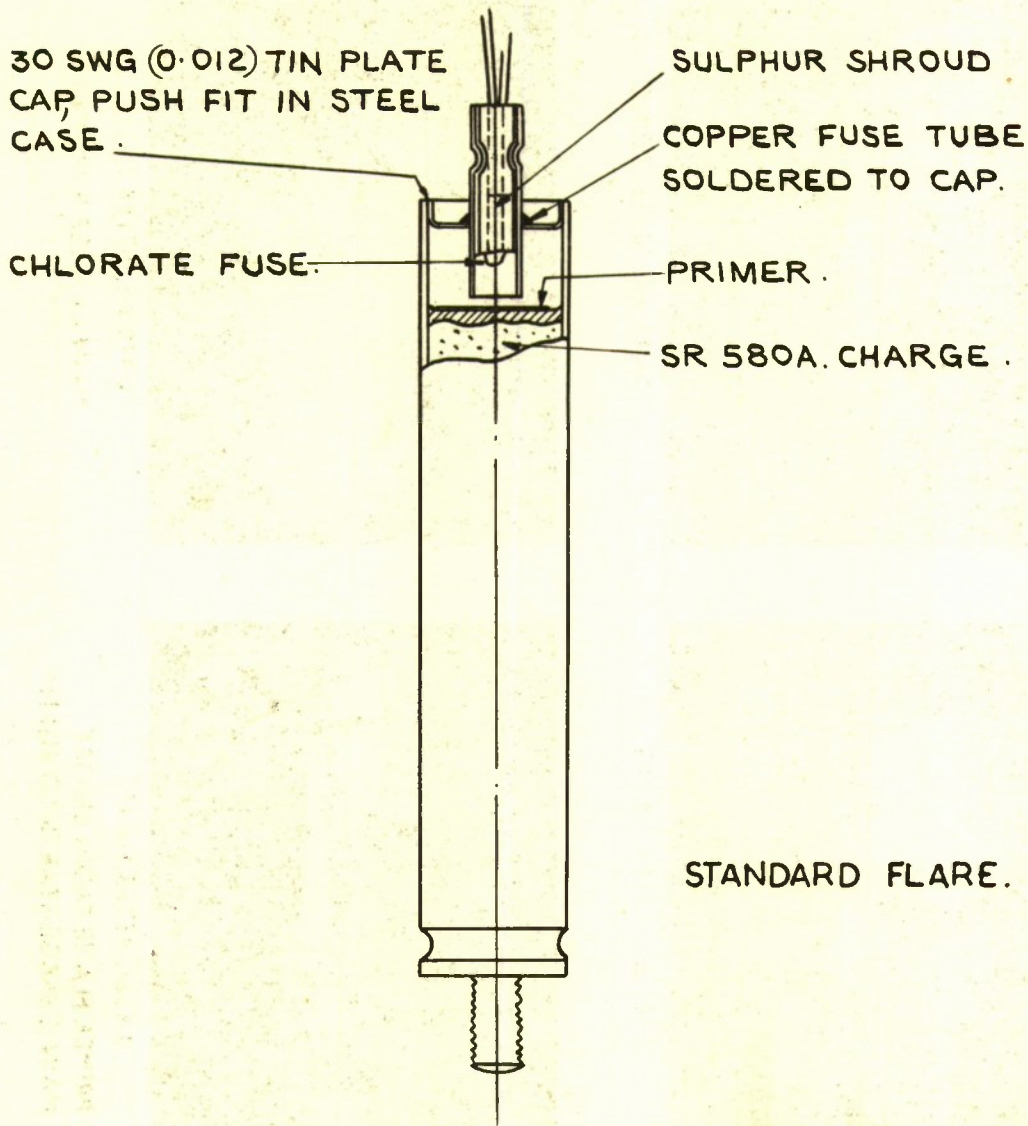

FIG. 1. RAMJET COMBUSTION CHAMBER SHOWING POSITIONS IN WHICH IGNITERS HAVE BEEN TESTED.



DETAILS OF MODIFICATIONS.

SCALE :- 1:1

FIG2.SR.580A 10 SEC.STANDARD TRACKING FLARE & DETAILS OF MODIFICATIONS.

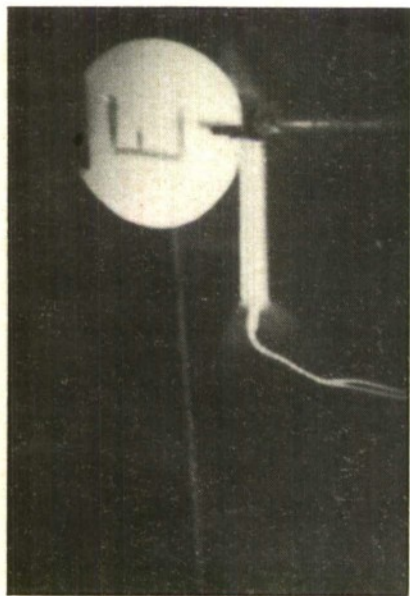

FIRED

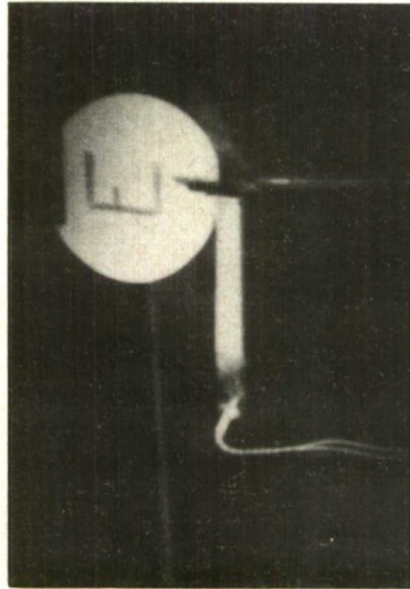

0.001 sec. AFTER FIRING

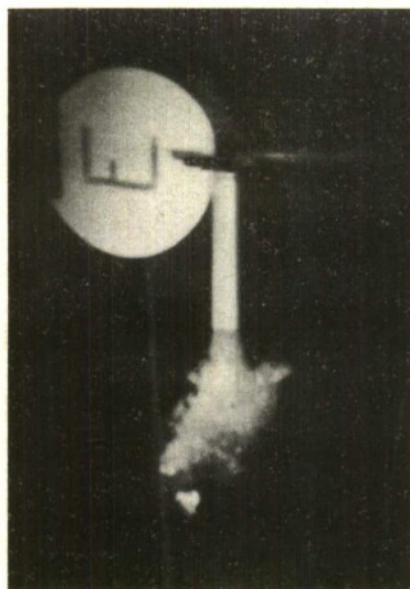

0.010 sec. AFTER FIRING

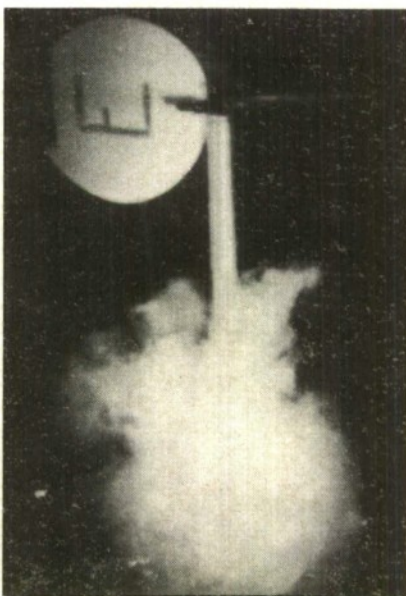

0.090 sec. AFTER FIRING

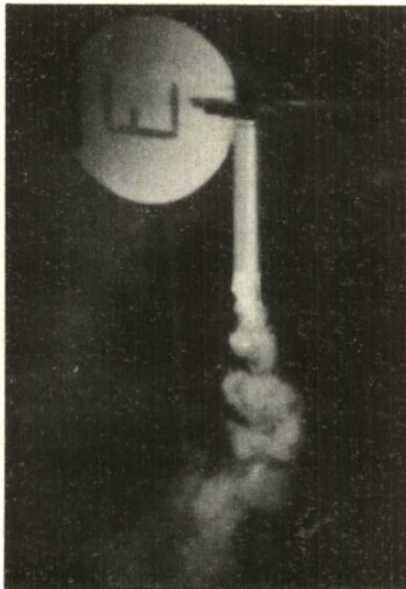

0.4 sec. AFTER FIRING
PRIMER FLAME FADES BEFORE
MAIN CHARGE STARTS TO BURN

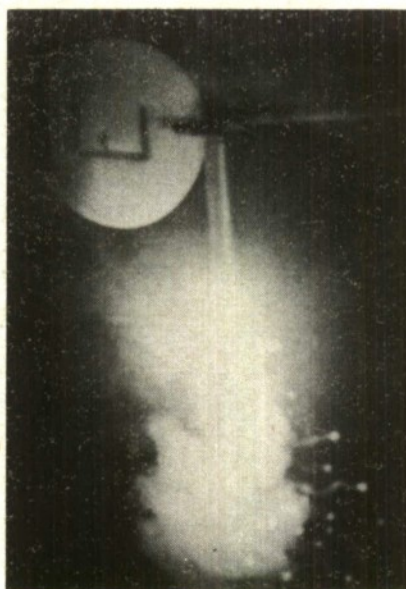

0.710 sec. AFTER FIRING
MAIN CHARGE BURNING

SCALE:- 2 in. = 1 ft.

FIG.3. EARLY STAGES OF BURNING OF A STANDARD 10 sec. TRACKING FLARE
(PRIMED WITH SR.252)

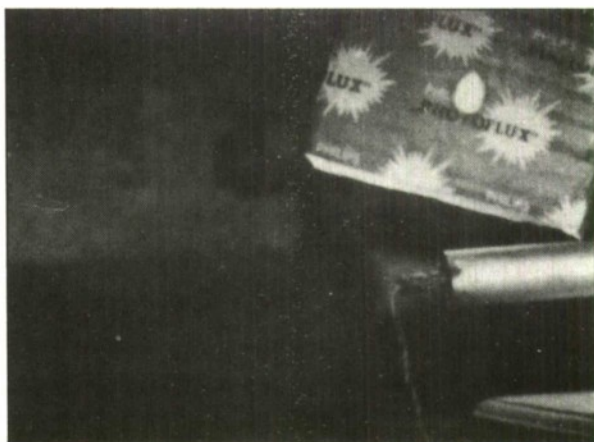

0.004 sec. AFTER FIRING

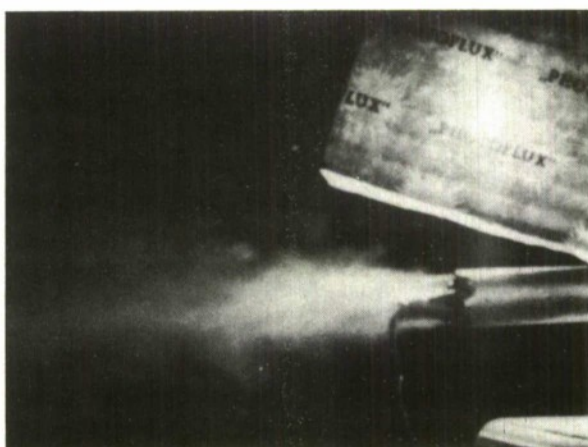

BURN THROUGH OF STEEL CAP
0.200 sec. AFTER FIRING



CAP BURNT AWAY AND CHARGE
BURNING 0.475 sec. AFTER FIRING

FIG.4. EARLY STAGES OF BURNING OF A
MODIFIED 10 sec. TRACKING FLARE
(CERIUM FUSE, NO PRIMER)

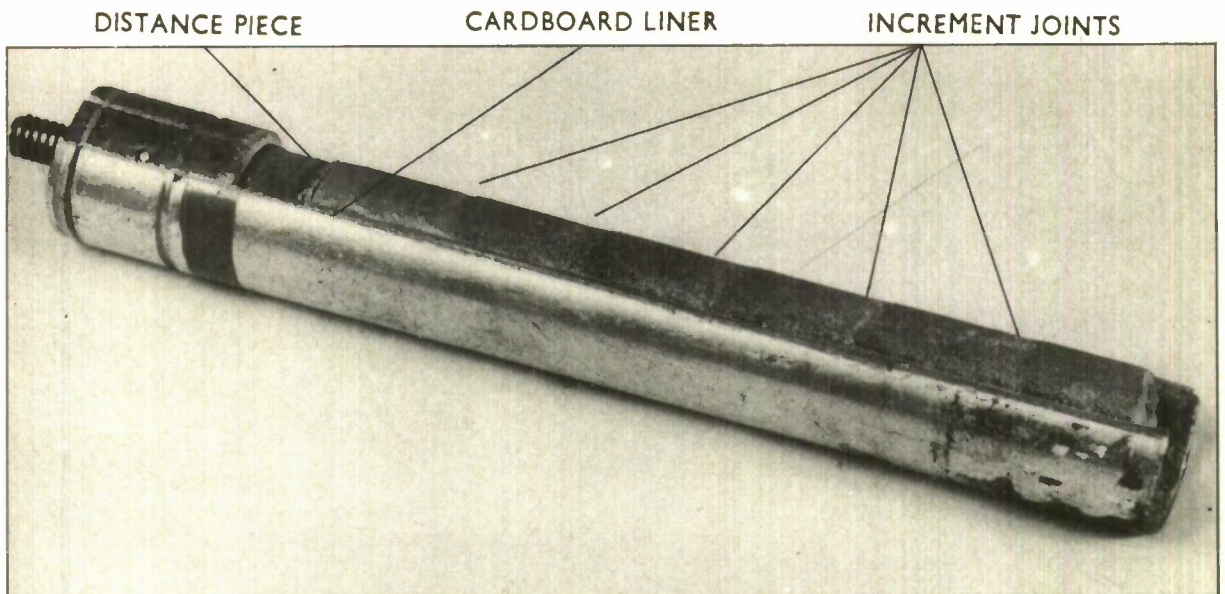

FIG.5. SECTION THROUGH CARDBOARD LINED FLARE

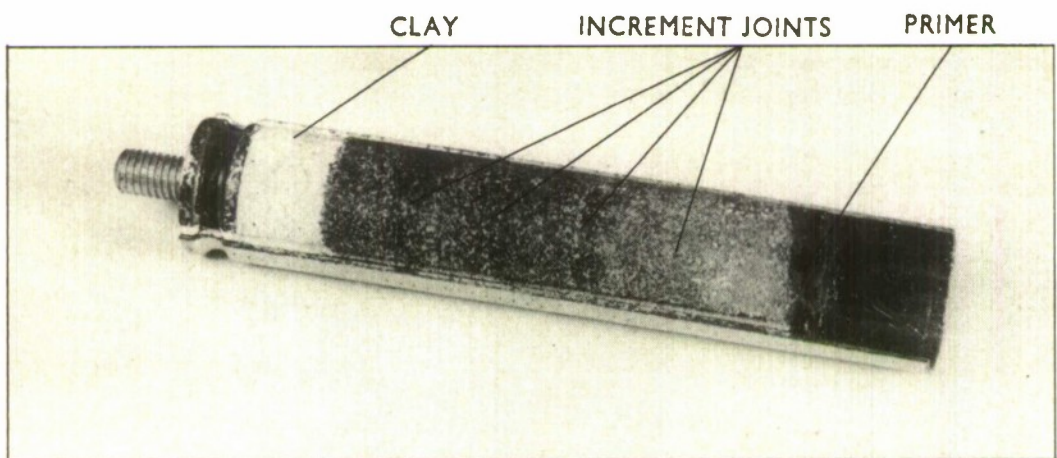

FIG.6. SECTION THROUGH AN UNLINED STEEL CASE FLARE

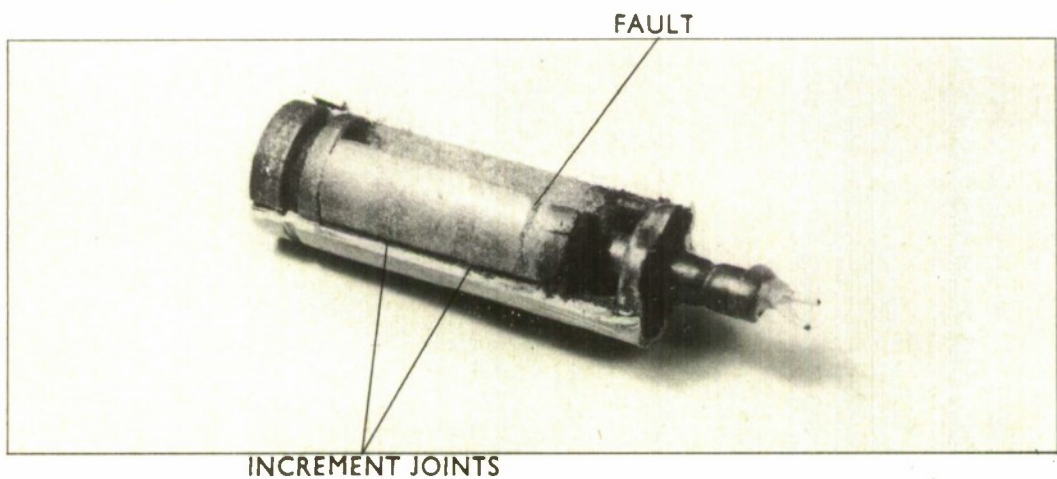
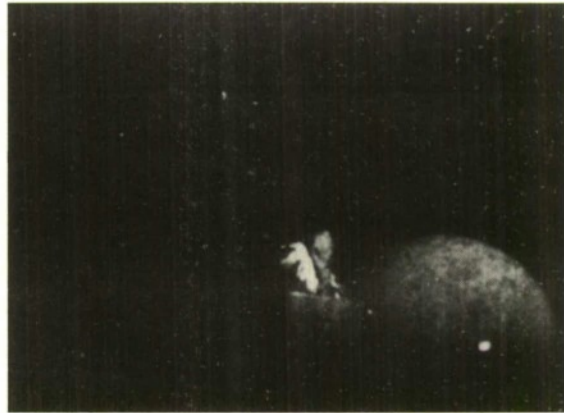
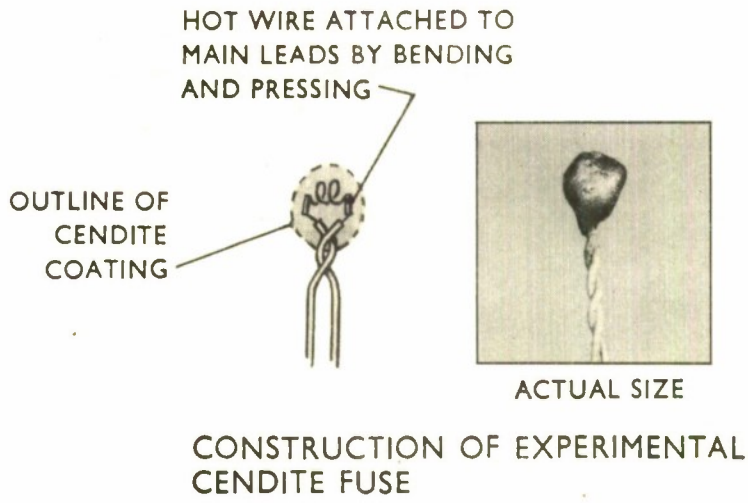

FIG.7. SECTION THROUGH SR 306-8 sec. IGNITER SHOWING FAULT WHICH CAN CAUSE A 'BLIND'



0.192 sec. AFTER FIRING



0.194 sec. AFTER FIRING



0.370 sec. AFTER FIRING

TOTAL BURNING TIME 1 sec. APPROX.

FIG.8. EXPERIMENTAL SR306 ("CENDITE") FUSE



IGNITERS IN POSITION



0.030 sec. AFTER FIRING. ESTIMATED
LAG OF R.H. IGNITER, 0.010 sec.



BURNING CHARGE BREAKING THROUGH
NEOPRENE CAP, 0.031 sec. AFTER FIRING

FIG.9. BURNING OF TYPE F7 IGNITERS IN
RAMJET FLAME HOLDING CONE
(AS FITTED IN J.T.V. TEST VEHICLE)

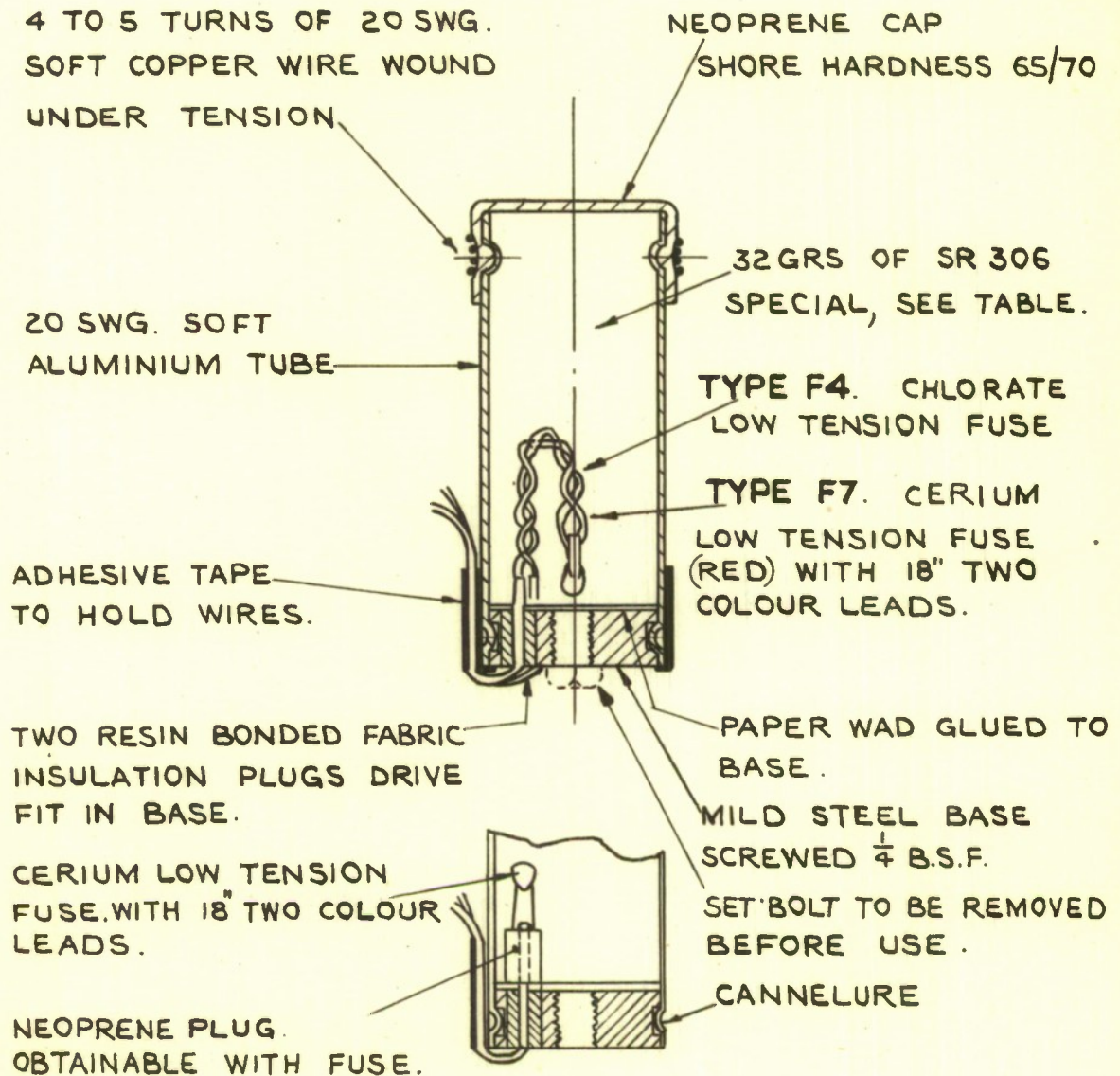

TYPE F6.

NOTE :-

SCALE :- 1:1

- (a) FOR MANUFACTURING DETAILS SEE R.A.E. SPECIFICATION G.W.58.
- (b) IGNITER COATED WITH CELLULOSE ACETATE.

FIG 10. DETAILS OF RAMJET FLASH IGNITERS.



NEOPRENE CAP OF IGNITER EXPANDING
0.019 sec. AFTER FIRING

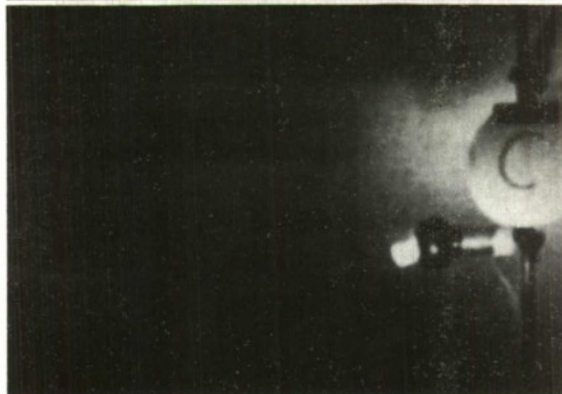

BURNING CHARGE BREAKING
THROUGH, 0.020 sec. AFTER FIRING

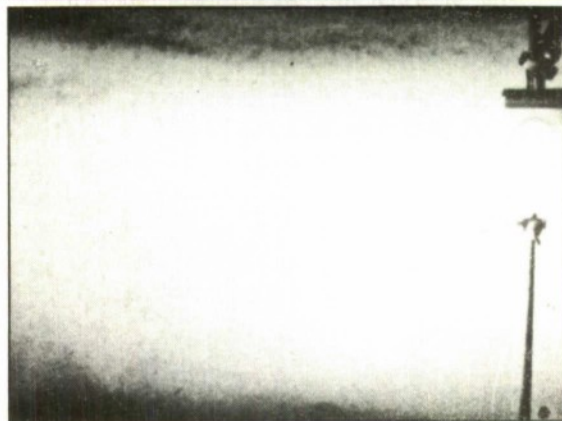

EXPLOSION, 0.021 sec. AFTER FIRING

SCALE:- $\frac{1}{8}$ in. = 1 in.



DISTANT VIEW SHOWING SHAPE
AND SIZE OF FLAME, 0.051 sec.
AFTER FIRING



PEAK OF EXPLOSION,
0.071 sec. AFTER FIRING

SCALE:- 1 in. = $1\frac{1}{2}$ ft.

FIG.11. SHOWING BURNING OF TYPE F7 IGNITER



NEOPRENE CAP LIFTING
0.034 sec. AFTER FIRING



INCOMPLETE COMBUSTION OF
CHARGE, 0.041 sec. AFTER FIRING



END OF FIRST EXPLOSION
0.060 sec. AFTER FIRING

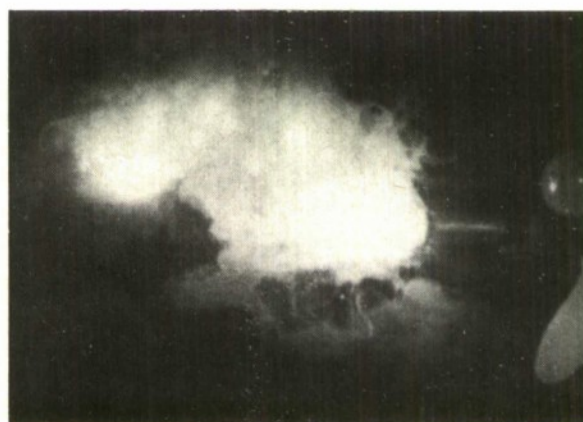

PEAK OF SECOND EXPLOSION
0.160 sec. AFTER FIRING

FIG.12. INCOMPLETE COMBUSTION OF CHARGE WHEN BURSTING PRESSURE OF CAP IS CONSIDERABLY REDUCED, (CAP NOT SECURED). TYPE F7 IGNITER



FIG.13. FLASH TYPE IGNITER FIRED UNDER 30g
SHOWING BURN THROUGH OF CASE



STORAGE PLUG TO BE
REMOVED BEFORE USE

FIG.14. TYPE F7 IGNITER

SCALE:- FULL SIZE

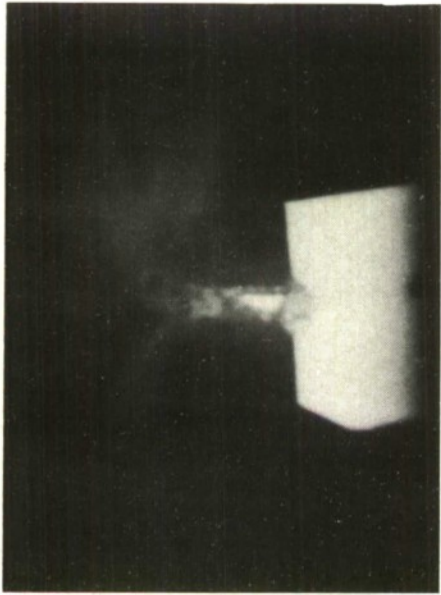

CHLORATE FUSE

FIRE

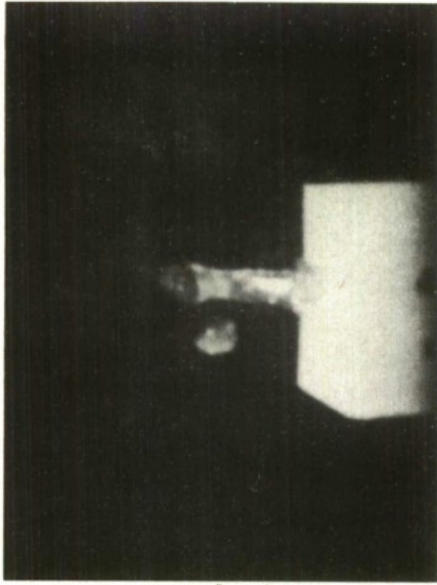

0-002 sec. AFTER FIRING

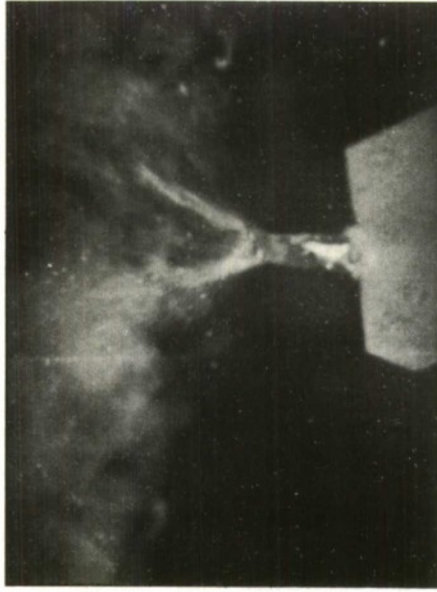

PEAK OF FLAME 0-058 sec. AFTER FIRING



CERIUM FUSE

FIRE



0-002 sec. AFTER FIRING



PEAK OF FLAME 0-005 sec. AFTER FIRING

FIG.15. COMPARISON OF CHLORATE AND CERIUM LOW TENSION FUSES. (CLOSE UP VIEW)



CHLORATE FUSE 0.014 sec. AFTER FIRING



CERIUM FUSE 0.007 sec. AFTER FIRING

SCALE:- APPROX. $\frac{1}{2}$ SIZE

FIG.16. COMPARISON OF PEAK FLAME, CHLORATE AND CERIUM LOW TENSION FUSES

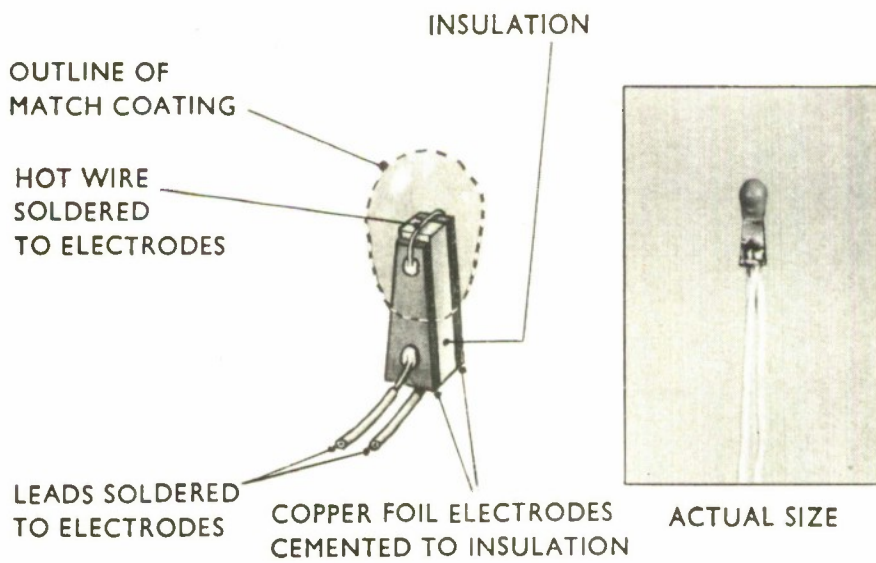
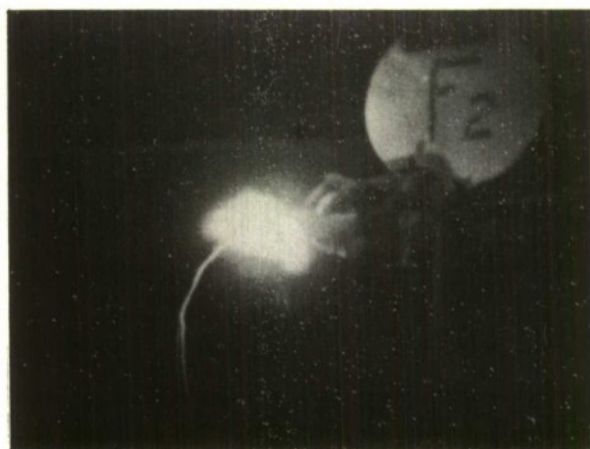
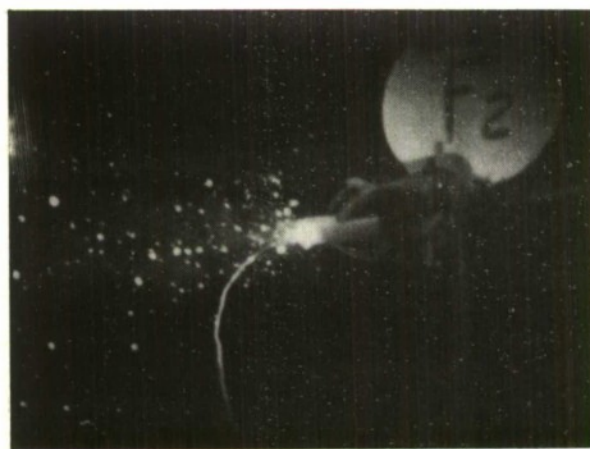

FIG.17. CONSTRUCTION OF LOW TENSION FUSE



BURNING 0.010 sec. AFTER FIRING



BURNING 0.330 sec. AFTER FIRING

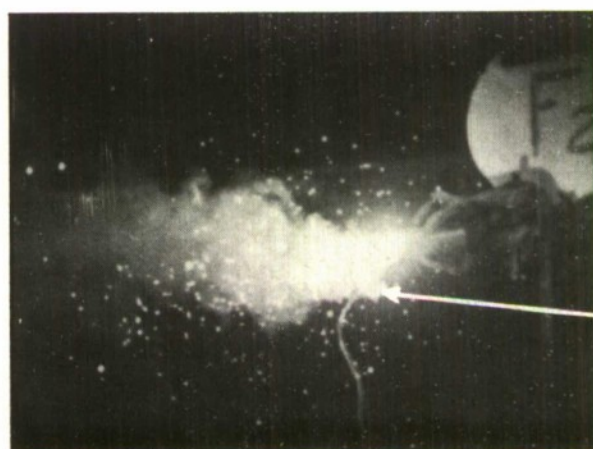

STEEL CAP BURNT AWAY
0.675 sec. AFTER FIRING

FIG.18. IGNITION OF COMPRESSED SR306 BY CERIUM
LOW TENSION FUSE WITHOUT PRIMER

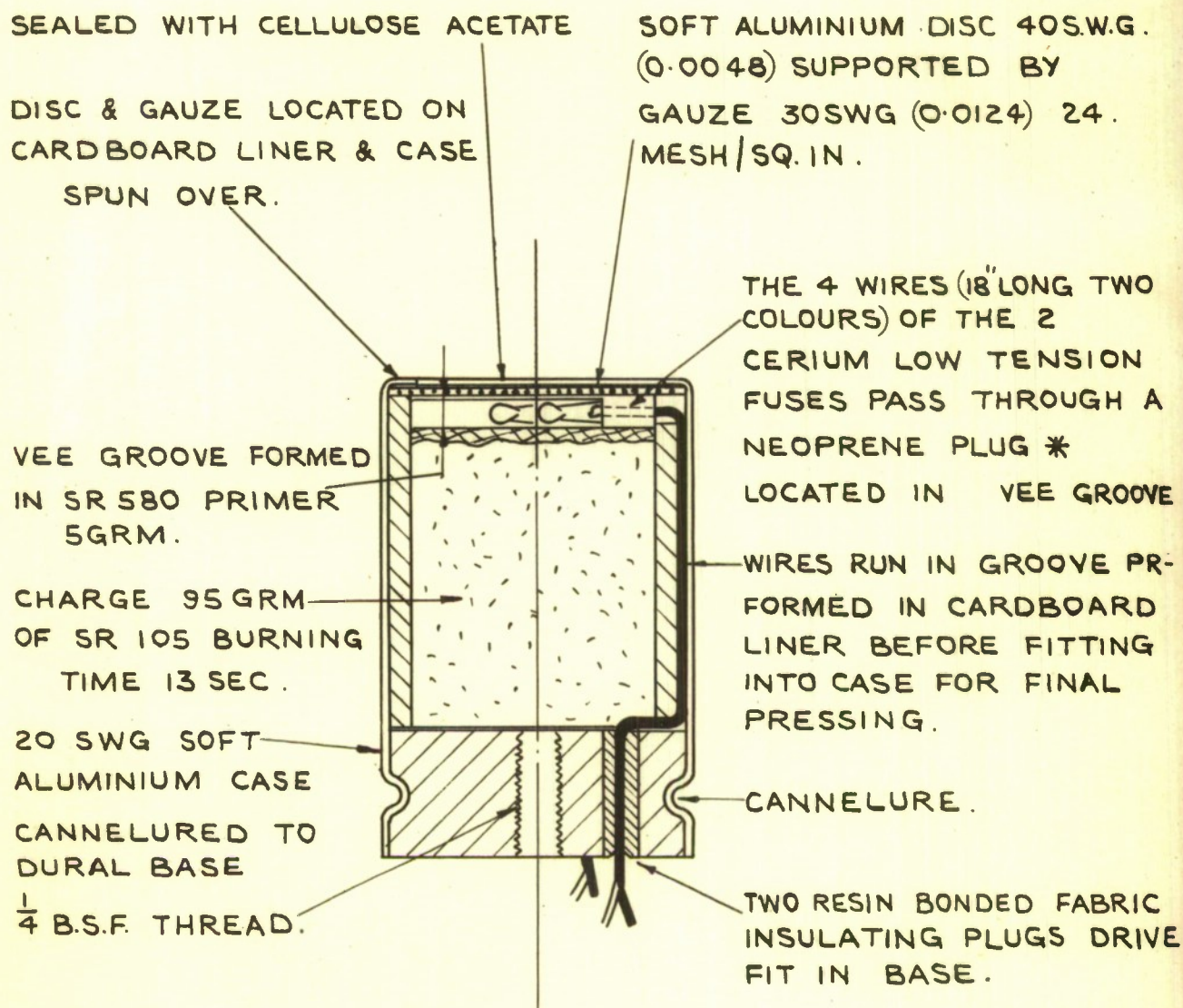

SCALE:- 1:1

NOTE :-

- (a) THE NEOPRENE FUSE PLUG * CAN BE OBTAINED WITH THE FUSE.
- (b) THE BASE OF THE IGNITER CAN BE REDUCED TO $\frac{3}{8}$ " THICK IF A LONGER BURNING TIME IS REQUIRED OR THE OVERALL HEIGHT REQUIRES REDUCTION.

FIG 19. DETAILS OF IMPROVED TYPE A.R.E.I.O. IGNITER



*Information Centre
Knowledge Services*
[dstl] Porton Down,
Salisbury
Wilts
SP4 0JQ
Tel: 01980-613753
Fax 01980-613970

Defense Technical Information Center (DTIC)
8725 John J. Kingman Road, Suit 0944
Fort Belvoir, VA 22060-6218
U.S.A.

AD#:
Date of Search: 16 February 2007

Record Summary:

Title: Development of pyrotechnic igniters for a 6 inch ramjet (RAE TN GW 200)
Covering dates 1952
Availability Open Document, Open Description, Normal Closure before FOI Act: 30 years
Former reference (Department) ARC 15102
Held by The National Archives, Kew

This document is now available at the National Archives, Kew, Surrey, United Kingdom.

DTIC has checked the National Archives Catalogue website (<http://www.nationalarchives.gov.uk>) and found the document is available and releasable to the public.

Access to UK public records is governed by statute, namely the Public Records Act, 1958, and the Public Records Act, 1967. The document has been released under the 30 year rule. (The vast majority of records selected for permanent preservation are made available to the public when they are 30 years old. This is commonly referred to as the 30 year rule and was established by the Public Records Act of 1967).

This document may be treated as UNLIMITED.