

ACTIVITIES ON TIME AND FREQUENCY AT SHANGHAI OBSERVATORY

Zhai Zaocheng, Zhuang Qixiang, Hu Jinlin and Kiu Wunwei
Shanghai Observatory
Chinese Academy of Sciences
Shanghai, China

ABSTRACT

The activities on time and frequency during recent two years at Shanghai Observatory are summarized as follows:

1. Atomic Frequency Standards. Several improvements to the H-masers and the primary laboratory's Cs standard were introduced at the Shanghai Observatory. A transportable hydrogen maser has been recently developed.

2. Atomic Time Scale. The recent progress in Shanghai Observatory's atomic time scale AT(SO) is described. The formation of the Chinese Joint Atomic Time (TAJ) is also presented.

3. Satellite T/F transfer. Recent developments in time synchronization via GMS ranging signal are discussed.

4. Time Service and T/F Applications.

5. Future Plans for Time and Frequency.

Shanghai Observatory is one of two observatories which are responsible for determining the national standard of frequency and for keeping Chinese standard time based on the Coordinated Universal Time (UTC) which is disseminated by BPM, BPL and XSG transmissions. To carry out these objectives, studies have been made on atomic frequency standards, atomic time scales, time transfer methods, including satellite techniques and other T/F measurement systems and so on. The following sections will deal with some of the results on these subjects during the past 2 years.

1. Atomic Frequency Standards

1.1 Hydrogen Maser

Shanghai Observatory began its hydrogen maser development at the beginning of 1970 and so far has developed 6 hydrogen masers which are of the typical construction of conventional hydrogen maser. Figure 1 shows one of them. Their design characteristics were described in References 3, 4, and 6. After 1984, three of Shanghai Observatory's hydrogen masers were improved again with the modifications of cavity-bulb assembly and beam optics. The modified masers showed a frequency stability of $7E-15$ for sampling time of 100 seconds.

Since 1985, development of a new hydrogen maser has begun. The new generation, shown in Figure 2, emphasizes the rigidity and mechanical and thermal stability, especially for the very critical cavity-bulb assembly. In the new design we absorbed

Report Documentation Page

*Form Approved
OMB No. 0704-0188*

Public reporting burden for the collection of information is estimated to average 1 hour per response, including the time for reviewing instructions, searching existing data sources, gathering and maintaining the data needed, and completing and reviewing the collection of information. Send comments regarding this burden estimate or any other aspect of this collection of information, including suggestions for reducing this burden, to Washington Headquarters Services, Directorate for Information Operations and Reports, 1215 Jefferson Davis Highway, Suite 1204, Arlington VA 22202-4302. Respondents should be aware that notwithstanding any other provision of law, no person shall be subject to a penalty for failing to comply with a collection of information if it does not display a currently valid OMB control number.

1. REPORT DATE DEC 1986	2. REPORT TYPE	3. DATES COVERED 00-00-1986 to 00-00-1986			
4. TITLE AND SUBTITLE Activities on Time and Frequency at Shanghai Observatory		5a. CONTRACT NUMBER			
		5b. GRANT NUMBER			
		5c. PROGRAM ELEMENT NUMBER			
6. AUTHOR(S)		5d. PROJECT NUMBER			
		5e. TASK NUMBER			
		5f. WORK UNIT NUMBER			
7. PERFORMING ORGANIZATION NAME(S) AND ADDRESS(ES) Shanghai Observatory, Chinese Academy of Sciences, Shanghai, China,		8. PERFORMING ORGANIZATION REPORT NUMBER			
9. SPONSORING/MONITORING AGENCY NAME(S) AND ADDRESS(ES)		10. SPONSOR/MONITOR'S ACRONYM(S)			
		11. SPONSOR/MONITOR'S REPORT NUMBER(S)			
12. DISTRIBUTION/AVAILABILITY STATEMENT Approved for public release; distribution unlimited					
13. SUPPLEMENTARY NOTES Proceedings of the Eighteenth Annual Precise Time and Time Interval (PTTI) Applications and Planning Meeting, Washington, DC, 2-4 Dec 1986					
14. ABSTRACT see report					
15. SUBJECT TERMS					
16. SECURITY CLASSIFICATION OF:			17. LIMITATION OF ABSTRACT Same as Report (SAR)	18. NUMBER OF PAGES 9	19a. NAME OF RESPONSIBLE PERSON
a. REPORT unclassified	b. ABSTRACT unclassified	c. THIS PAGE unclassified			

many design ideas of the masers which were developed by Dr. R.F.C. Vessot in SAO (Reference 1). The possible cavity-stress change owing to the expansion co-efficient is taken up by a special washer called the Belleville spring, similarly, thermal-induced radial stress on the base is relieved by rollers. In order to increase thermal stability, the cavity is made of CER-VIT, a material of unbeatable dimensional stability and long-term resistance to dimensional creep, and with a thermal co-efficient of $1E-8$ per degree centigrade. The storage bulb was made to be very thin (160 grams) so as to reduce thermal mistuning of the cavity due to the change of temperature coefficient of dielectric constant within the resonator.

Another major departure between the new design and the old masers is the size of dissociator glassware and the layout of the RF coil. The change in dissociator size is an increase in volume by a factor of 2. The magnetic shield consists of four layers of 1J85 moly permalloy.

Design experience with the old maser has shown that temperature gradients are a problem. This can be solved by including separate zones of thermal control for the bell jar and the oven. The temperature controller has achieved a precision of 0.001 per degree centigrade.

The new generation is being assembled now. Hopefully, it will be made to oscillate by the end of this year.

1.2 Lab Cs standard

The Lab Cs standard which is used at Shanghai Observatory was originally built by the National Institute of Metrology of China in Beijing. Since 1980, it has been improved at Shanghai Observatory. The improved design is described in References 3, 4 and 5. Evaluation showed its frequency stability to be about $5E-13$ /hour, while its accuracy is about $2E-12$.

Since 1985, the Lab Cs standard has been continually improved with the following designs:

1. Redesigned and fabricated the U-cavity with a single waveguide without any connectors on it instead of the original cavity construction which consisted of nine pieces of waveguide. This will reduce the frequency shift due to phase difference.
2. Redesigned and fabricated two permanent magnets instead of the original electrical one. In order to increase magnetic field strength and gradient, the new design adapts a large radius and a big aperture between the two poles.
3. The other components such as oven, detector and C-field construction were also redesigned and refabricated. Figure 3 shows the new beam optics with the new parts assembled.
4. Two ion pumps were added to the vacuum system so as to increase pumping speed and raise the vacuum limitation.

Hopefully, the improved Cs standard will be working by the middle of next year. It is expected that the new design will give better performance.

2. Atomic Time Scales

2.1 The atomic time scale at Shanghai Observatory

Shanghai Observatory's atomic time scale (marked AT(SO) and UTC(SO)) was established on January 8, 1978. Since then, it has been developing step by step and its performance level has also progressed gradually. The formation and algorithm were described in References 2, 3 and 5. The related improvements during recent years are introduced briefly as follows:

The time-keeping clock assembly now consists of four sets of commercial Cs clocks (one is with high performance tube) instead of the original Rb clocks.

A new time measuring system which can automatically monitor and collect data was established. It is equipped with a time counter (HP5370A) with resolution of 20ps, and is controlled by a computer. We also built a 1pps time difference automatic measurement system (1pps-TDAMS) with measuring precision of 0.2 ns for short-term time difference and 1 - 1.5 ns for long-term (Reference 7) as well as an experimental dual mixer time difference automatic measurement system (DMTD-AMS) with time difference measuring precision of 1 - 2 ps and frequency measuring precision of $2E-12$ /second, $5E-15$ /hour and $5E-16$ /day (Reference 8).

There is no humidity control in our atomic time Lab. Using recent long-term internal and external comparison data, we discovered that the time fluctuations of commercial Cs clocks at Shanghai Observatory have a corresponding periodical phenomena with seasonal humidity changes. After deducting the effect of the humidity changes, the time fluctuation and the rate fluctuation of clocks(SO) are improved by about 40%. Therefore, we have posed an atomic time algorithm with weight average and periodical rate correction (WAPRC). According to the change of the average humidity every month in the Lab., a periodical rate correction term is added into the weight average time scale. Thus, the uniformity of the AT(SO) is obviously improved.

Since 1984, AT(SO) has become one of 11 independent atomic time scales which are employed by BIH in the world. In order to see the level of AT(SO), taking the TAI-TA(SO) data which are published by BIH from January 1986 to August 1986 for example, the time fluctuation is about 89 ns rms and the frequency stability is about $7.6E-14$ (with sample time of 10 days). In addition, for the atomic clock weights, the average weight of the clocks(SO) from February 1984 to April 1986 is about 134 which has exceeded the average weight (about 121) of all clocks which are taking part in the BIH system during the same period.

2.2 The Joint Atomic Time Scale

The Chinese Joint Atomic Time Scale (TAJ) was established as a high precision time and frequency reference, which is based on the MOWA algorithm and many sets of commercial Cs clocks, hydrogen masers and a primary Lab Cs standard distributed nationwide, and linked by many kinds of synchronization techniques, such as LF, TV and portable clock. The system consists of the clocks of Shaanxi Observatory(CSAO), Shanghai Observatory(SO), Beijing Observatory(BAO), Wuchang Time Observatory of Institute of Geodesy and Geophysics(WTO) and Beijing Radio Institute of Metrology and Test(BRIM). The CSAO is responsible for the unified calculation and publishing the "Time & Frequency Bulletin". TAJ is coordinated with UT which is determined by astronomical observation to form the UTC(JM) reference. The basic structure of the system is shown in Figure 4. The "Time & Frequency Bulletin" of TAJ has been published

since October 1985. The primary results show $2E-14$ of uniformity and $3E-13$ of frequency accuracy. And the UTC(JM) is synchronized to 5 us with respect to UTC(BIH) and has a frequency stability of $2E-13$ /day.

3. Satellite T/F Transfer

Time and frequency transmission on HF band at Shanghai Observatory has been carried out for a long period of time and varieties of time comparisons and synchronization methods have been experienced and conducted, such as Loran-C, TV synchronization, portable clock, laser pulses and geostationary satellites. The details have been described in Reference 9.

Recently, the work on time transfer using the ranging signal of the Japanese Geostationary Meteorological Satellite (GMS-3) is under way in Shanghai Observatory. GMS is located at 140 degree east longitude, so it is suitable for precise time comparison between China, Japan and other countries in Asia. A receiver for the ranging signal has been developed at Shanghai Observatory, which demodulates the 27.8 khz and 200 khz side-tone ranging signal for time comparison purposes. During the receiver-measuring test in March of 1986, a residual standard deviation of 17.4 ns for single measurement has been achieved. The block diagram of Shanghai Observatory's receiving system with 6 meters antenna is shown in Figure 5, and the photo of the measuring system is shown in Figure 6. The delay of the receiving system at Shanghai Observatory will soon be measured, and a microcomputer will be incorporated into the measuring system. After that, a time comparison experiment between Shanghai Observatory and Radio Research Laboratories, Japan, will be routinely conducted.

Due to the high accuracy of the ranging signal measurements, research work on satellite positions and motion will also be performed by using the simultaneous measurement data at three ground stations.

4. Time Service and T/F Application

The time service function is carried out at Shanghai Observatory through time signal transmissions (XSG and civil time radio broadcasting), T/F metrology and the publishing of the "Atomic Time Bulletin" for the users of both regional and nationwide.

Time and frequency standards also play an important role in several research projects of at the Shanghai Observatory, such as VLBI, Satellite Laser Ranging, Doppler Observation by man-made satellite, Earth Rotation and Geodynamics. Having a stable time and frequency standard as well as an accurate time synchronization link are the core for those applications mentioned above.

During recent years, Shanghai Observatory has built a new VLBI system which consists of a 25 meter antenna (Figure 7) and a Mark III terminal. A third generation Satellite Laser Ranging System has also been completed. With these advanced systems, new prospects for clock synchronization experiments via VLBI and Laser ranging at Shanghai Observatory have been opened up.

5. The Future Plan for Time and Frequency

5.1 The primary Lab Cs standard is being improved and is expected to have better performance. It will make atomic time scales AT(SO) and TAJ more accurate and independent.

- 5.2 The research work on the hydrogen maser will be continued. With the increase in stability and reliability, it will join the timekeeping clock assembly, so as to improve the short to mid-term uniformity of the atomic time scale.
- 5.3 Research work on timing, positioning and satellite orbit determination are planned using GPS and geostationary satellite.
- 5.4 Using the advanced timing systems of the Shanghai Observatory, VLBI clock synchronization and Laser time comparison experiments are expected with other time and frequency laboratories around world.

For all the activities planned and mentioned above, anyone interested in cooperating will be welcomed.

REFERENCES

- (1). Levine(M.W), Vessot(R.F.C) etc., "A Hydrogen Maser Design for Ground Application" Proc. of the 8th PTTI meeting, 1976
- (2). Atomic time Lab., "The Independent Atomic Time Scale at Shanghai Observatory" Annals of Shanghai Observatory, 1980
- (3). Chi-hsiang Chuang and Tzauh-cheng Jair, "Atomic Time and Frequency Standards Development at Shanghai Observatory, China" IEEE Trans IM-29, No3,1980
- (4). Zhai Zao-cheng, "Shanghai Observatory's Hydrogen Masers" JIETE Vol 27,11, 1981
- (5). Zhuang Qi-xiang, "Application of ARIMA Model to the Forecasting of Atomic Time" Annals of Shanghai Observatory, 1982
- (6). Zhai Zao-cheng, Zhuang Qi-xiang, "A Brief Introduction to the Atomic Time and Frequency Standards at Shanghai Observatory" Proc. of 38th Annual Symposium on Frequency Control, 1984
- (7). Hu Jin-lin, "The Analysis of Measuring Precision of 1pps Time-difference Automatic Measuring System" Annals of Shanghai Observatory, 1985
- (8). Hu Jin-lin, "Dual Mixer Time Difference Automatic Measuring System and Its Applications" Annals of Shanghai Observatory, 1985
- (9). Zhuang Qi-xiang, "Time Dissemination at Shanghai Observatory" Proc. of the 17th PTTI meeting, 1985

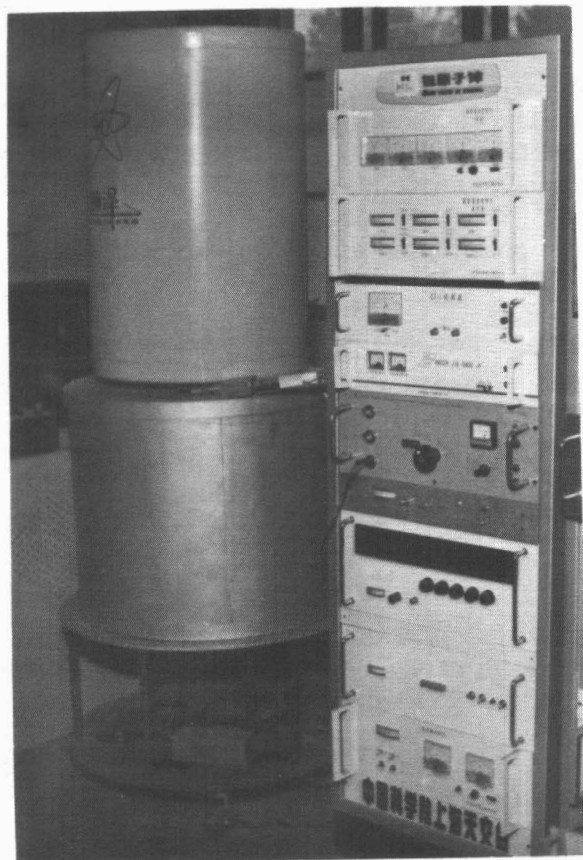

Fig.1 H6 hydrogen maser

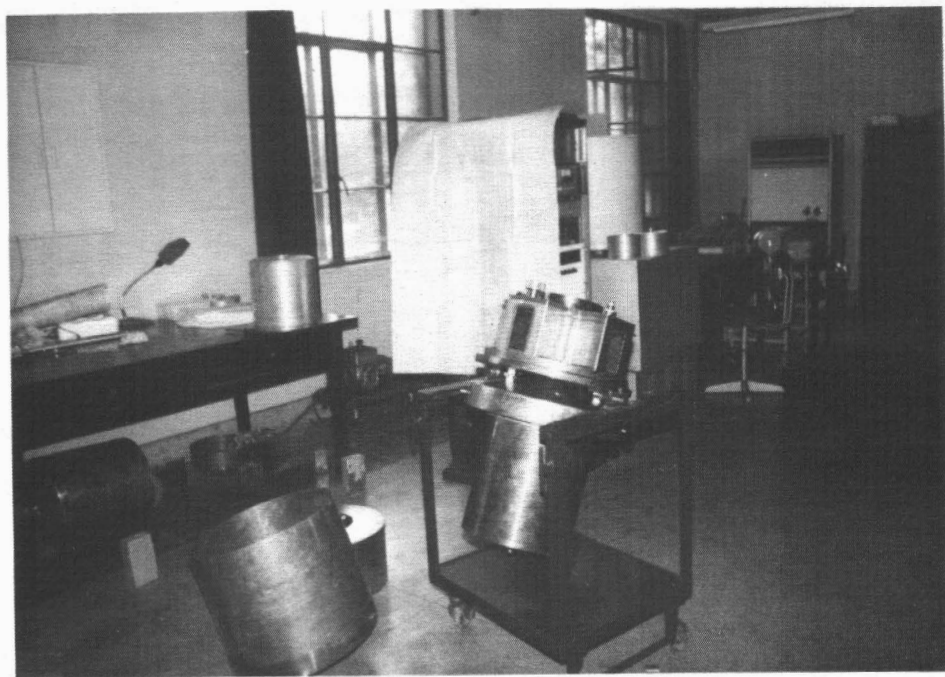

Fig.2 The new hydrogen maser

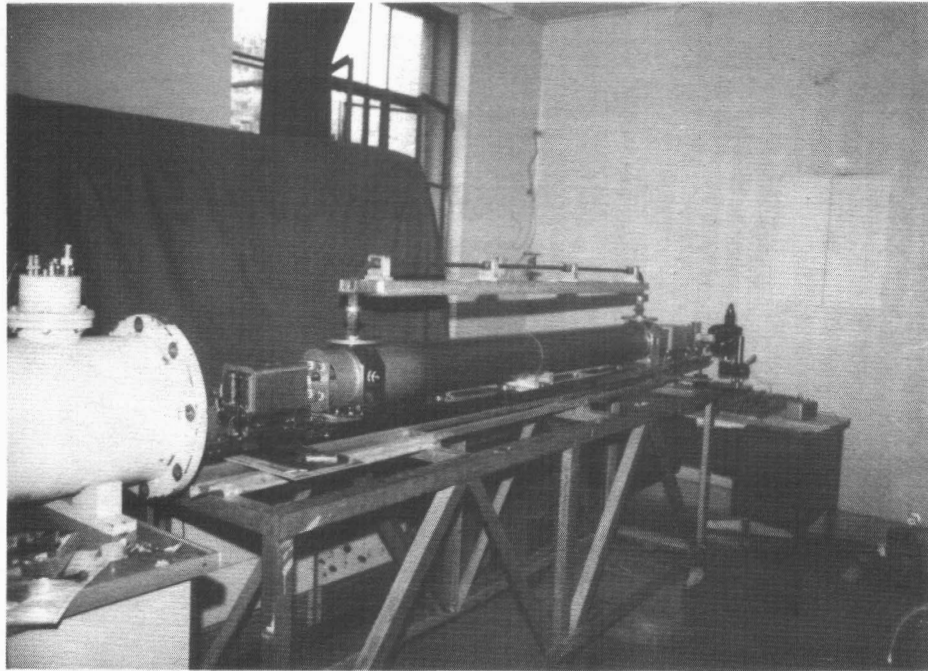

Fig.3 The improved Lab Cs standard

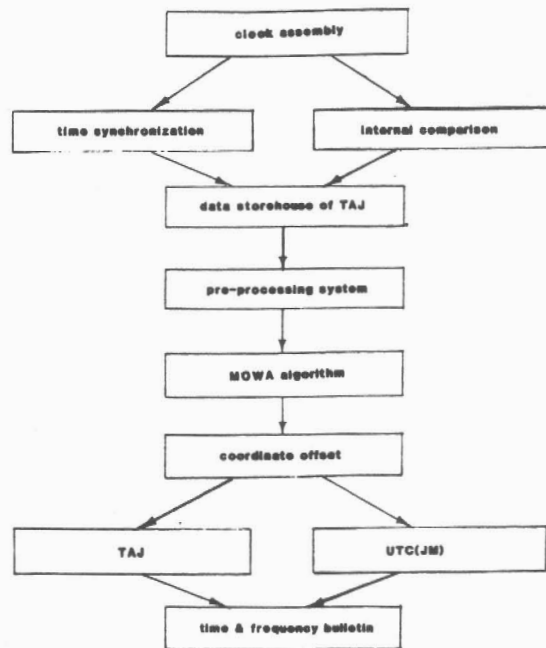

Fig.4 The structure of TAJ system

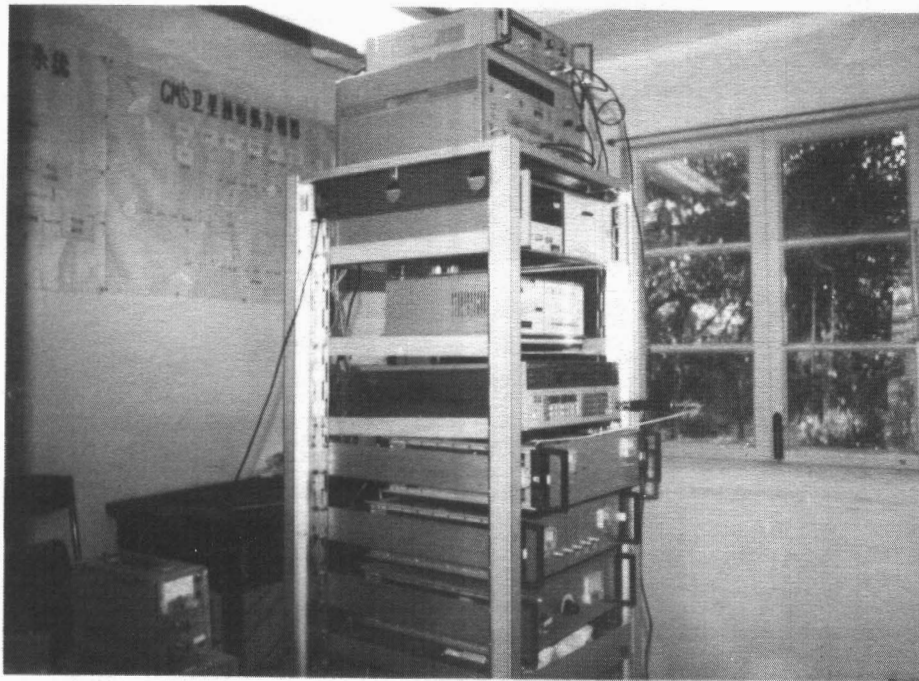

Fig.5 The measuring system of GSM receiver

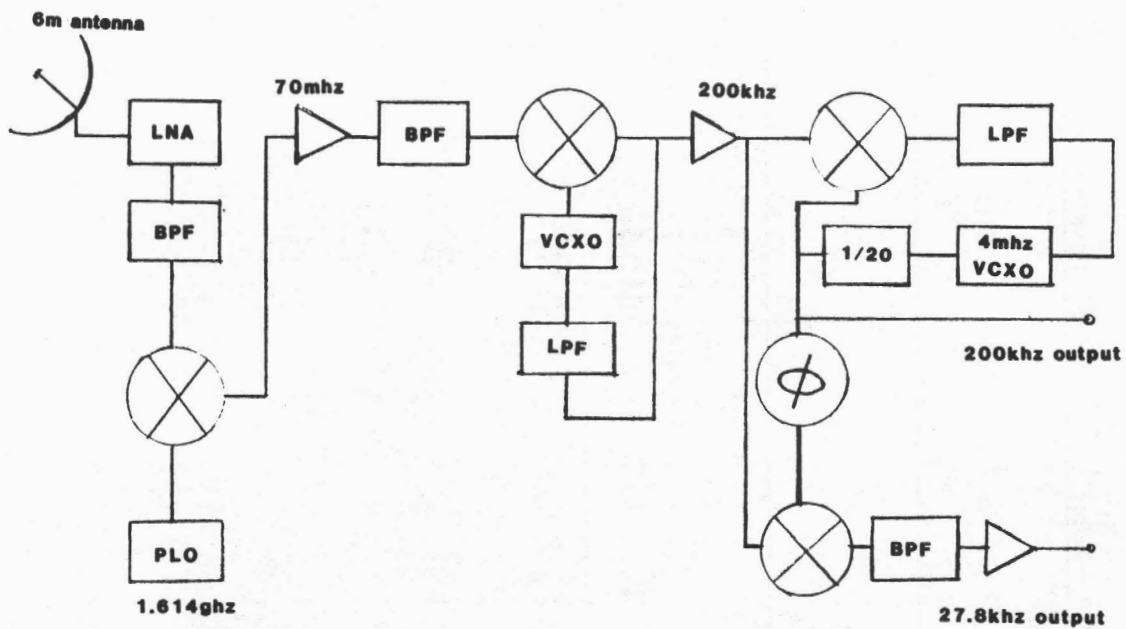

Fig.6 The block diagram of GSM receiving system

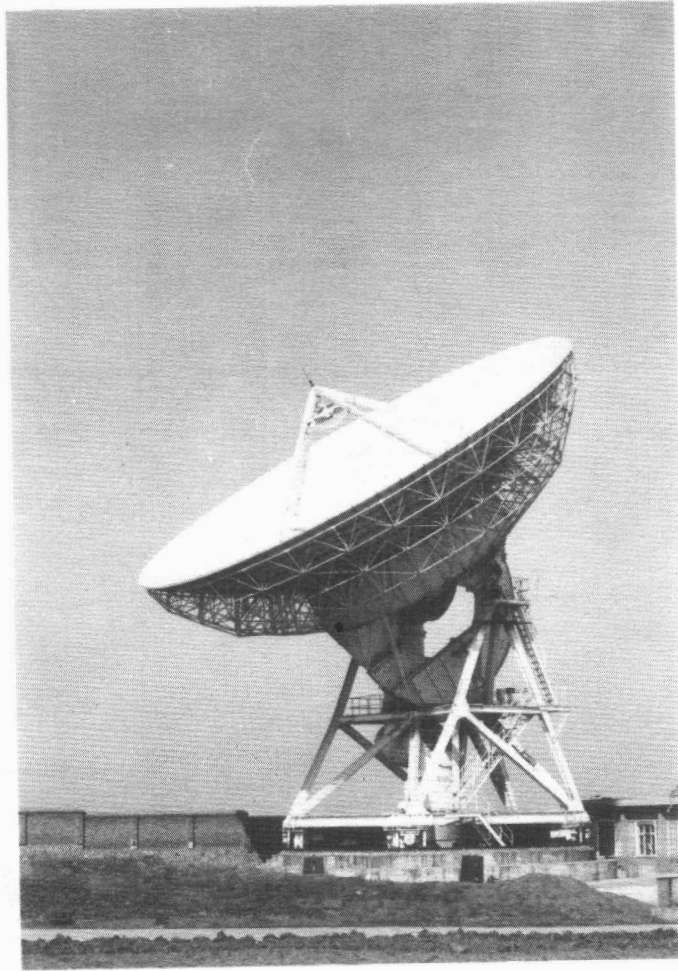

Fig.7 The 25 meter antenna for VLBI