

IRAQI CIVIL DEFENSE
HEADQUARTERS
BAGHDAD, IRAQ

SIGIR PA-06-090
APRIL 26, 2007

Report Documentation Page

Form Approved
OMB No. 0704-0188

Public reporting burden for the collection of information is estimated to average 1 hour per response, including the time for reviewing instructions, searching existing data sources, gathering and maintaining the data needed, and completing and reviewing the collection of information. Send comments regarding this burden estimate or any other aspect of this collection of information, including suggestions for reducing this burden, to Washington Headquarters Services, Directorate for Information Operations and Reports, 1215 Jefferson Davis Highway, Suite 1204, Arlington VA 22202-4302. Respondents should be aware that notwithstanding any other provision of law, no person shall be subject to a penalty for failing to comply with a collection of information if it does not display a currently valid OMB control number.

| | | | | | |
|--|------------------------------------|-------------------------------------|----------------------------|---|---------------------------------|
| 1. REPORT DATE 26 APR 2007 | | 2. REPORT TYPE | | 3. DATES COVERED 00-00-2007 to 00-00-2007 | |
| 4. TITLE AND SUBTITLE Iraqi Civil Defense Headquarters Baghdad, Iraq | | | | 5a. CONTRACT NUMBER | |
| | | | | 5b. GRANT NUMBER | |
| | | | | 5c. PROGRAM ELEMENT NUMBER | |
| 6. AUTHOR(S) | | | | 5d. PROJECT NUMBER | |
| | | | | 5e. TASK NUMBER | |
| | | | | 5f. WORK UNIT NUMBER | |
| 7. PERFORMING ORGANIZATION NAME(S) AND ADDRESS(ES) Office of the Special Inspector General for Iraq Reconstruction, 400 Army Navy Drive, Arlington, VA, 22202-4704 | | | | 8. PERFORMING ORGANIZATION REPORT NUMBER | |
| 9. SPONSORING/MONITORING AGENCY NAME(S) AND ADDRESS(ES) | | | | 10. SPONSOR/MONITOR'S ACRONYM(S) | |
| | | | | 11. SPONSOR/MONITOR'S REPORT NUMBER(S) | |
| 12. DISTRIBUTION/AVAILABILITY STATEMENT Approved for public release; distribution unlimited | | | | | |
| 13. SUPPLEMENTARY NOTES | | | | | |
| 14. ABSTRACT | | | | | |
| 15. SUBJECT TERMS | | | | | |
| 16. SECURITY CLASSIFICATION OF: | | | 17. LIMITATION OF ABSTRACT | 18. NUMBER OF PAGES | 19a. NAME OF RESPONSIBLE PERSON |
| a. REPORT unclassified | b. ABSTRACT unclassified | c. THIS PAGE unclassified | | | |



SPECIAL INSPECTOR GENERAL FOR IRAQ RECONSTRUCTION

April 26, 2007

MEMORANDUM FOR DIRECTOR, IRAQ RECONSTRUCTION MANAGEMENT
OFFICE
COMMANDING GENERAL, GULF REGION DIVISION,
U.S. ARMY CORPS OF ENGINEERS

SUBJECT: Report on Iraqi Civil Defense Headquarters, Baghdad, Iraq (Report Number
SIGIR PA-06-090)

The Office of the Special Inspector General for Iraq Reconstruction is providing this report for your information and use. We assessed the design and construction work being performed at the Iraqi Civil Defense Headquarters compound located in Baghdad, Iraq to determine whether the intended objectives of the contract will be achieved. This assessment was made to provide you and other interested parties with real-time information on relief and reconstruction projects to enable appropriate action to be taken, if warranted. The assessment team included two engineers/inspectors and three auditors/inspectors.

The comments received from the Commanding General, Gulf Region Division in response to a draft of this report addressed the recommendations, and the actions taken and planned should address the issues we identified. As a result, comments to this final report are not required.

We appreciate the courtesies extended to our staff. If you have any questions please contact Mr. Brian Flynn at brian.flynn@sigir.mil or at 914-360-0607. For public or congressional queries concerning this report, please contact SIGIR Congressional and Public Affairs at publicaffairs@sigir.mil or at 703-428-1100.

Stuart W. Bowen, Jr.
Inspector General

Special Inspector General for Iraq Reconstruction

SIGIR PA-06-090

April 26, 2007

Iraqi Civil Defense Headquarters, Baghdad, Iraq

Synopsis

Introduction. This project assessment was initiated based on an official request by the Gulf Region Division Facilities and Transportation Sector representatives. The overall objectives were to determine whether completed projects complied with the terms of their contracts and task orders and to evaluate the effectiveness of the monitoring and controls exercised by administrative quality assurance and contract officers. We conducted this project assessment in accordance with the Quality Standards for Inspections issued by the President's Council on Integrity and Efficiency. The assessment team included two engineers/inspectors and three auditors/inspectors. The overall objective of the project was to fully renovate the Civil Defense Headquarters and other buildings on the site to become a fully operational and usable facility.

Project Assessment Objectives. The objective of this project assessment was to provide real-time relief and reconstruction project information to interested parties to enable appropriate action to be taken, when warranted. Specifically, we determined whether:

1. Project components were adequately designed prior to construction or installation;
2. Construction or rehabilitation met the standards of the design;
3. The contractor's quality control plan and the U.S. Government's quality assurance program were adequate;
4. Project sustainability was addressed; and
5. Project results were consistent with original objectives.

Conclusions. The assessment determined that:

1. Not all project components were adequately designed prior to renovation and construction at the Iraqi Civil Defense Headquarters. The United States Army Corps of Engineers could not locate the required 30% and 60% design submittal packages; instead providing only the 100% final design drawing submittal package. Without the required design submittal packages, we could not determine if the requisite information was included. In addition, the government representative who apparently had access to the design submittal packages, rejected the 30% and 90% design drawings because they were incomplete and lacked important information necessary for construction.

We reviewed the design drawing submittal marked as the 100% final drawing package and found it inadequate due to the absence of quality, detailed design construction drawings. The contractor's drawings lacked significant and basic design details, such as the rough-in and finish-out for the installation of plumbing fixtures (a riser diagram for both fresh water and soil piping) and the need for an adequate number of cleanouts and traps. Without detailed design drawings, the subcontractor does not have adequate guidance to properly install the water lines and plumbing fixtures. In addition, the submitted design drawings did not include

electrical design for each line identifying the amount of load on one particular breaker and the number of outlets and/or lighting fixtures on each line. The absence of this critical information significantly increases the potential for a short circuit, which could lead to an electrical fire.

Further, with regards to the Sally Port gates, we believe the mechanism to move the gate from one end to the other was not adequately designed and configured. A properly designed steel rolling gate would have included load calculations, such as the weight of the gates while in motion, to determine the correct size motor to operate the gates. The motor provided does not have adequate horse power to move the gate; consequently, the motor cannot produce the required torque to operate the gates. In addition, another poorly designed aspect of this gate system is that it does not provide any locking mechanism once it reaches the destination point (the other wall). The intent of this gate was to provide explosive-proof security for the Iraqi Civil Defense Headquarters compound, which means prohibiting a suspected vehicle from entering the compound. However, there are no mechanisms to keep the door in the intended (locked) position.

2. Instances were noted in which work performed did not meet the standards of the contract and task order. The contract and task order identified the minimum standards for construction, such as the International Plumbing Code and International Electro-Technical Committee. We identified construction deficiencies such as poor plumbing, electrical, and Sally Port gate installations. In addition, the plumbing work did not comply with the prescribed international standards.
3. The contractor's quality control plan was sufficiently detailed, including the use of daily quality control reports to document construction deficiencies; yet the contractor's quality control program implementation failed to identify significant construction deficiencies, such as poor plumbing installation practices. Specifically, the daily quality control reports did not identify any construction deficiencies or international standard violations. In addition, the daily quality control reports did not contain any test and/or inspection results. Further, no quality control deficiency log existed for this project.

The government quality assurance program was not fully operational. The daily quality assurance reports were vague and did not document critical information, such as insight into any problems encountered at the site. The Quality Assurance Representative's site photographs showed deficiencies; however, the root cause of the problem was not addressed and corrective actions, if taken, were not always documented. In addition, the Quality Assurance Representative did not identify any instances in which the subcontractor did not follow the required international standards. Obvious violations of the International Plumbing Code, such as exposed sewer pipes leading from the ground floor bathroom to the outside manhole, were not identified and corrected.

4. Sustainability was addressed in the task order requirements, but not adequately administered. Documented instances of non-compliance with contract and task order required international standards for plumbing and electrical installation, give concern that the existing problems will worsen over time and render at least part of the Iraqi Civil Defense Headquarters buildings unusable. For example, the continuing water leakage onto the ground floor Operations Room has already limited the use of a portion of the Operations Room; while the electrical fires

around the fluorescent light fixtures present continual safety problems for the entire headquarters facility.

Further, the as-built drawings submitted by the contractor, in many cases, do not reflect the work that was actually done. Accurate information in the as-built drawings is needed for proper operations and maintenance, effective warranty enforcement, and future repair and renovation work.

Finally, according to the United States Army Corps of Engineers, the basic contract warranties provide provisions against poor quality workmanship by the contractor; while the task order warranties provided provisions for equipment and materials only. In addition, United States Army Corps of Engineers representatives described the cost plus task order as a “level of effort” agreement and the only provisions against poor quality workmanship are latent defects and fraud. They do not believe the contractor’s performance for this project constituted fraud or latent defects; therefore, they contend there is no remedy for the poor quality workmanship identified throughout this report under the warranties clause of this task order. Also, the United States Army Corps of Engineers stated that in order to enforce the warranties, the government would have to pay the contractor for its overhead costs under an Administrative Task Order. As a result, the United States Army Corps of Engineers indicated that it had determined it would be more cost effective to issue local contracts for the warranty repairs.

5. The Iraqi Civil Defense Headquarters is occupied and used by the Iraqi Civil Defense Directorate for its headquarters’ functions. However, the renovation and construction results were not fully consistent with the original contract and task order objectives. At the time of our inspections, the renovated main office buildings were experiencing plumbing failures and electrical fires, which will leave the Iraqis with continual maintenance issues.

The United States Army Corps of Engineers representatives pointed out that the water leaks may be due to installation of showers by the Iraqi Civil Defense Headquarters’ staff after completion of contract work. Though the showers installed by Iraqi Civil Defense Headquarters’ staff were a minimum of 27 feet from the site of the water leak, it is possible that the showers were responsible for the leak or some portion of the leak. Additionally, upon being alerted to the electrical fires the United States Army Corps of Engineers initiated immediate action to determine the cause of the fires.

Recommendations. We recommend that the Commanding General, Gulf Region Division:

1. Determine the cause of the plumbing leaks and take action to repair any portion due to deficient work on the part of the U.S. Government contractor
2. Complete the investigation initiated during our assessment to determine the cause of the electrical fires. If the light fixtures are the cause, require the manufacturer to replace all lighting fixtures throughout the facility. If the light fixtures are not the cause of the electrical fires, seek additional funding to perform an engineering analysis to determine the specific cause of the electrical fires.

Management Comments. The Gulf Region Division concurred with comments to SIGIR’s recommendations noting that Iraqi Civil Defense personnel had occupied the Headquarters building for 24 months and that in that time numerous modifications had

emerged such as the addition of showers and rewiring of electrical fixtures. Despite the problems identified in the report, the facility is functional and in daily use by several hundred employees.

GRD explained that since the building occupants had employed self-help construction, it could be difficult to ascertain if deficiencies stem from the original construction or if they are compounded by self-help modifications. Nevertheless, GRD committed to conducting an assessment of the identified plumbing and electrical discrepancies within 30 days of the publication of this final report and to pursue corrective actions for any deficiencies related to the original contractor's work.

Evaluation of Management Comments. Management comments addressed the issues raised in the reports. The Gulf Region Division's planned actions are responsive and should identify the cause(s) of the plumbing and electrical deficiencies. The appropriate corrective actions will be taken by the Gulf Region Division once the origins of the plumbing and electrical deficiencies are identified.

Table of Contents

| | |
|---|----|
| Synopsis | i |
| Introduction | |
| Objective of the Project Assessment | 1 |
| Pre-Site Assessment Background | 1 |
| Contract, Task Order and Costs | 1 |
| Project Objective | 1 |
| Description of Facility (pre-construction) | 1 |
| Scope of Work of the Task Order | 4 |
| Project Design and Specifications | 4 |
| Site Assessment | |
| Work Completed | 8 |
| Test Results and As-Built Drawings | 45 |
| Work In Progress and Work Pending | 52 |
| Project Quality Management | |
| Contractor Quality Control Program | 55 |
| Government Quality Assurance Program | 56 |
| Project Sustainability | 59 |
| Conclusions | 60 |
| Recommendations | 62 |
| Management Comments | 63 |
| Evaluation of Management Comments | 63 |
| Appendices | |
| A. Scope and Methodology | 64 |
| B. Contract, Task Orders, and Modifications | 65 |
| C. Acronyms | 67 |
| D. Report Distribution | 68 |
| E. Management Comments | 70 |
| F. Assessment Team Members | 74 |

Introduction

Objective of the Project Assessment

The objective of this project assessment was to provide real-time relief and reconstruction project information to interested parties to enable appropriate action to be taken, when warranted. Specifically, we determined whether:

1. Project components were adequately designed prior to construction or installation;
2. Construction or rehabilitation met the standards of the design;
3. The contractor's quality control (QC) plan and the U.S. government's quality assurance (QA) program were adequate;
4. Project sustainability was addressed; and
5. Project results were consistent with original objectives.

Pre-Site Assessment Background

Contract, Task Order, and Costs

The Iraqi Civil Defense Headquarters (ICD HQ) project was completed under Contract W914NS-04-D-0009, dated 26 March 2004, as a cost plus award fee for the base period. The contract was between the Coalition Provisional Authority and Parsons Delaware, Inc., Pasadena, California (Parsons). Contract W914NS-04-D-0009 minimum cost, including option periods, was \$500,000 and the maximum total of all task orders under the contract was \$900,000,000.

There was one task order (TO) associated with this particular contract – TO 02. TO 02, dated 24 April 2004, was not to exceed \$742,450.00. Modification 01, dated 12 July 2004, definitized the TO to renovate the ICD HQ in the amount of \$1,354,583.00. Modification 08, dated 2 June 2005, increased the TO to \$3,000,064.00.

For a detailed list of the basic contract, contract modifications, TO, and TO modifications, see Appendix B.

Project Objective

The overall objective of TO 02 was to fully renovate the ICD HQ and other buildings on the site to a fully operational and usable facility for the headquarters' sections. Additional work was added to the original scope of work (SOW) to expand the interior and exterior of the facilities to accommodate additional room space for all departments of the Civil Defense Ministry of Interior.

Description of the Facility (pre-construction)

The description of the facility (pre-construction) was based on information obtained from the contract, the United States Army Corps of Engineers (USACE) Gulf Region Division (GRD) project file, and Iraqi Civil Defense Directorate (ICDD) personnel. The project site is located at the existing ICD HQ compound in Baghdad, Iraq. The surrounding area consists of residential homes and government buildings, such as the

Ministries of Human Rights and Trade, and the abandoned Iraqi National Congress building. The existing facility consists of one three-story main headquarters building, a separate two-story building providing additional office and training space for department personnel, and three small, independent rooms housing the generator, transformer, and pump. The main headquarters building is an L shaped building located on the middle of the complex; while the other buildings are located along the western section of the complex (Figure 1). The original facility was constructed in 1991; however, severe looting and burning after the 2003 war left the ICD HQ buildings severely dilapidated and in need of significant rehabilitation (Site Photos 1 through 4).

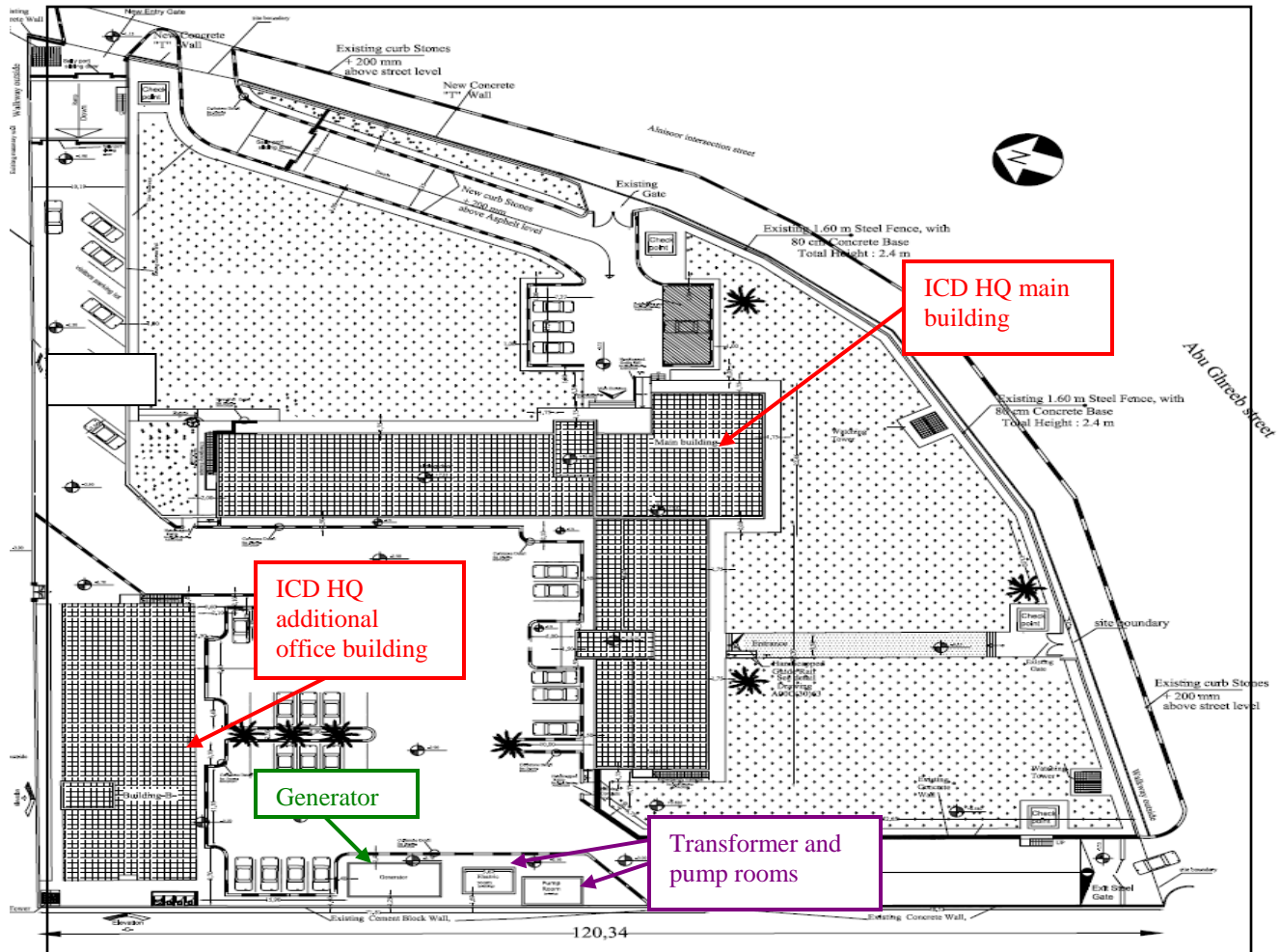

Figure 1. Layout of the ICD HQ compound



**Site Photo 1. Exterior view of the existing ICD HQ building
(Photo courtesy of the USACE)**



**Site Photo 2. Exterior view prior to renovation
(Photo courtesy of the USACE)**



**Site Photo 3. View of ICD HQ hallway after severe looting in 2003
(Photo courtesy of the USACE)**



**Site Photo 4. Previously existing generator room
(Photo courtesy of the USACE)**

Scope of Work of the Task Order

The intent of TO 02 was to “fully renovate the Civil Defense Headquarters and the site to a fully operational and usable facility for the Headquarters’ functions.” This required reconstruction and renovation, which included expanding the interior and exterior of the compound facilities in order to accommodate all departments of the ICD HQ. Project work included the following:

- repairing plumbing and renovating restrooms
- installing safety and fire alarm systems
- renovating and replacing security facilities
- repairing and replacing the electrical system
- upgrading the mechanical and structural facilities

Additional work was added to the Scope of Work (SOW) in November 2004, which consisted of the design, construction, and renovation of the following:

- transformer
- parking area and entrance for the Director General (DG)
- check points
- guard towers
- fire exits
- Sally Ports
- Texas barriers
- bathrooms

Project Design and Specifications

The contractor was required to provide design, calculations, computer aided design drawings, complete as-built drawings, and manuals in English and Arabic. In addition, the contractor was required to submit the following to the Sector Project Management Office (SPMO) or Resident/Project Engineer:

- 15% (conceptual) design
- 30% (renovation) design
- 60% (new construction or structural repair) design

The TO required the design and installation of equipment, materials, and work to conform to the following standards, except where otherwise indicated. (a) Underwriters Laboratories Inc. listed material, (b) German standards, or (c) British standards. Equipment enclosure types shall be in compliance with the National Electrical Manufacturer’s Association or the International Electro-Technical Committee’s standards. Material and equipment installed under this contract shall be for the appropriate application and locally available. The contractor may propose equipment, material, and work that meet the intent of the publications listed here, provided documented justification requests for such alternates are submitted and approved by the SPMO.

- International Building Code (IBC)
- International Existing Building Code (IEBC)
- International Electro-Technical Committee (IEC)
- International Fire Code (IFC)
- International Plumbing Code (IPC)
- American Society for Testing and Materials (ASTM)
- American Concrete Institute (ACI)
- International Mechanical Code (IMC)

According to the contract's SOW, design reviews are required to determine: the quality of the design, incorporation of value engineering opportunities, systems integration, meeting of operational and functional objectives, maintenance of costs within the budget, constructability, cost effectiveness, and final compliance of construction documents with design criteria and relevant codes. In addition, "construction cannot proceed without approval by the SPMO of all construction documents."

According to GRD documentation, the contractor submitted 30% renovation design drawings, 90% design drawings, and 100% final design drawings for review; however, GRD could not locate the actual 30% design and 90% design drawings for our review. Instead, we relied upon the government's review of the 30% design drawings and 90% design drawings, which occurred on 8 July 2004 and 21 September 2004, respectively. For the 30% design drawings, the government representative did not find the submittal package to be complete, since he specifically requested the contractor submit "Electrical and Mechanical Drawings;" while for the 90% design drawings, the government representative recommended the design drawings be "rejected" because they are "incomplete and lack important information necessary for construction."

Due to the lack of the required design drawing submittals, we were unable to determine if the submittals included the following:

- site plans – with existing and new underground/above ground utilities
- elevations
- architectural plans – with construction details
- HVAC plans – with construction details and equipment installation details
- plumbing plans – with rough-in and finish-out details
- repair plans – showing limits and types of finishes
- electrical plans and electrical single line diagram – showing details for equipment installation, schedules of fixtures, and mains and branch circuit distribution detail

Specifically, we needed to determine if the design submittal package included:

- mechanical design featuring flow diagrams
- system layouts
- electrical distribution system design including flow diagrams
- system layouts
- specifications for the station's electrical substation and electrical generator

A submittal log was needed to document and track the following information:

- number of design and product/equipment submittal
- date of original submittal
- type of submittal
- description of submittal
- name of government representative assigned/reviewing the design submittals
- approval/rejection of submittal with comments and notes
- status (if previously rejected)
- corrective actions were addressed from the rejected submittals
- final approval and acceptance of submittal

As a result, construction on the ICD HQ continued even though the contractor had not provided the adequate and complete design drawing submissions.

We reviewed the design drawing submittal marked as the 100% final drawing package and found them inadequate due to the absence of quality, detailed design construction

drawings. It is customary to show construction detail for individual items as well as Typical Details for items or components used at multiple locations. All construction detail shows the material, method, and critical dimensions to perform the task for the benefit of the installer. The contractor's drawings lacked significant and basic design details, such as the rough-in and finish-out for the installation of plumbing fixtures (a riser diagram for both fresh water and soil piping) and the need for an adequate number of cleanouts and traps. Further, there was a significant omission with regards to the location and correct type of building expansion joints.

Detailed design drawings for the rough-in and finish-out of the plumbing fixtures were not provided by the contractor. Instead the drawings were generic and did not specify the distance the hot and cold water lines should extend beyond the wall (i.e. rough-in) for the plumber to connect to the shower faucet and head (Figure 2). In addition, the drawings do not provide an enlargement of one toilet or shower as an example to provide specific installation details, such as the type of plumbing fixtures to use (i.e. finish-out). Without detailed design drawings, the subcontractor does not have adequate guidance to properly install the water lines and plumbing fixtures.

Based upon our review of the GRD design submittal documentation, it appears inadequate to renovate and construct the ICD HQ. Without the required design submittal packages, we could not determine if the requisite information was included. In addition, the government representative who apparently had access to the design submittal packages, rejected the 30% and 90% design drawings because they were not complete and lacked important information.

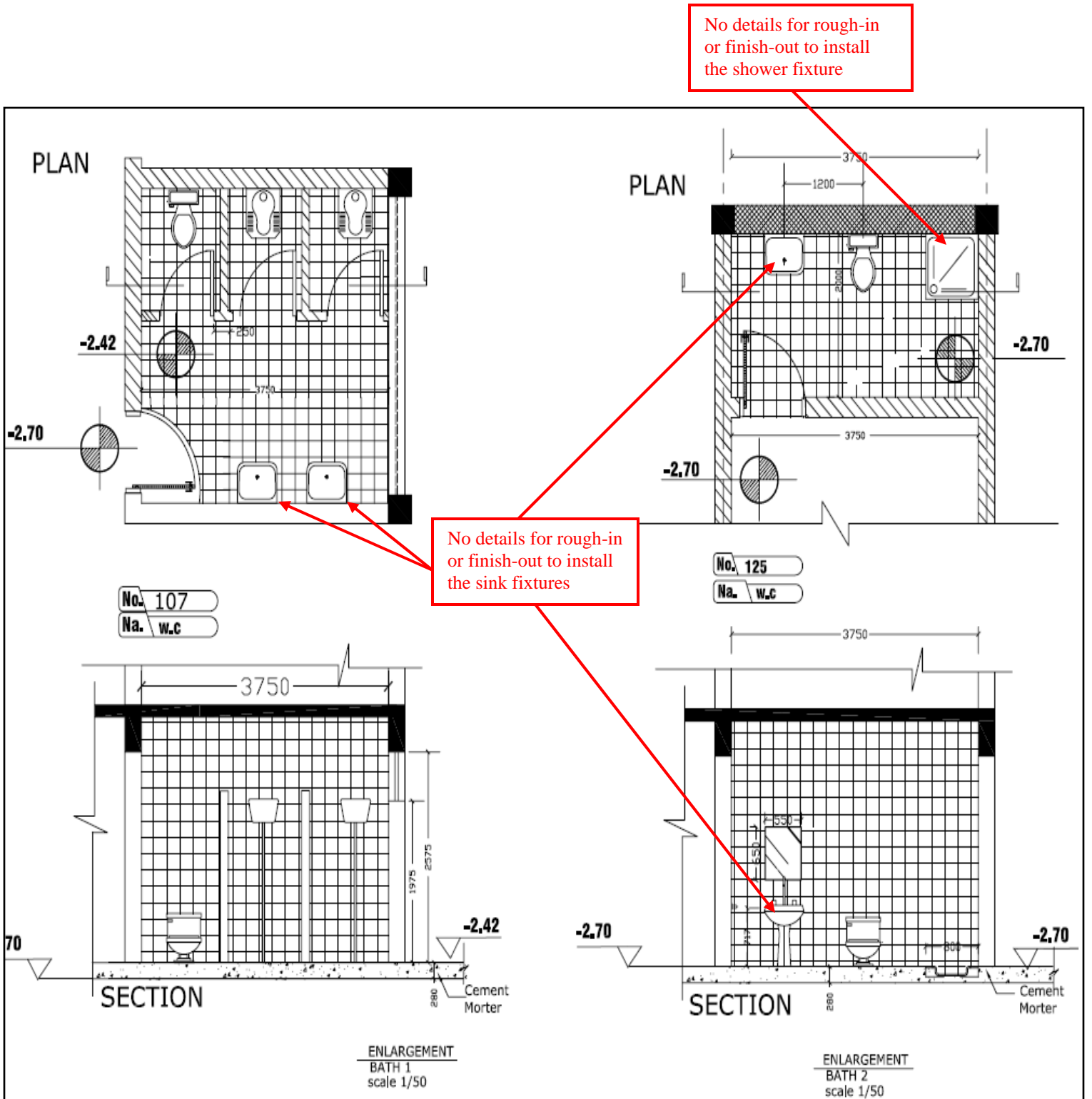

Figure 2. Contractor's as-built drawing for building A bathroom (enlargement)

Site Assessment

On 24 January 2007, 27 February 2007, 12 March 2007, and 12 April 2007 we performed on-site assessments of the ICD HQ project. On our first site visit, we were accompanied by ICD engineers, the USACE GRD Deputy Program Director, and the GRD audit liaison; while on our last site visit, we were accompanied by the USACE Gulf Region Central (GRC) Commander and Project Engineer (PE).

During our site visits we observed ICD HQ personnel conducting day to day business within the facility.

Work Completed

According to the USACE GRD, at the time of our initial site visit, Parsons had completed all of the project requirements, with the exception of outstanding “punch list” warranty work by the subcontractor.

Repairing Plumbing and Renovating Bathrooms

Within the ICD HQ main building, there are 13 bathrooms (three on the ground floor, six on the first floor and four on the second floor). The ICD HQ main building was designed with the four second-floor bathrooms located directly above five of the six first-floor bathrooms; while the five first-floor bathrooms are directly above the ground floor Operations Room (Figures 3, 4, 5, and 6). According to the contractor’s as-built drawings, there are four different styles of bathrooms, varying by the number of toilets, sinks, and showers in each one. Water and other waste materials from the showers, wash basins, and toilets drain from the second floor to the first floor to the ground floor.

The original ICD HQ bathrooms were destroyed as a result of the looting and burning in 2003 (Site Photos 5 and 6), which required new bathroom facilities. The TO SOW required the contractor to furnish the labor and materials to completely restore the ICD HQ bath and toilet rooms. The TO SOW specifically stated the “design and construction must comply” with the IPC. In addition, the TO specifically stated that the “plumbing system shall be installed and/or repaired complete with necessary fixtures, fittings, traps, valves, drains and accessories to be fully operational and free of leaks.”

During our site visits, we identified water damage within the ICD HQ bathrooms (Site Photos 7 and 8). Our observations, coupled with discussions with ICD HQ personnel and review of daily QA reports, suggest the bathroom plumbing installation did not adhere to the standards of the IPC.

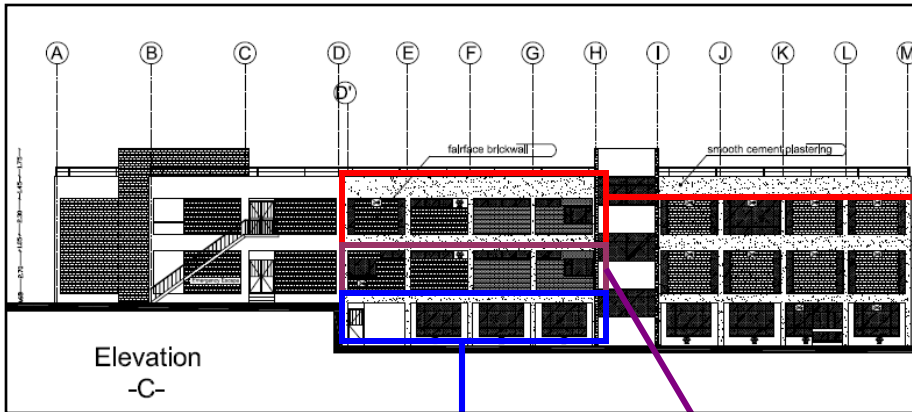

Figure 3. Cross section view of the ICD HQ main building

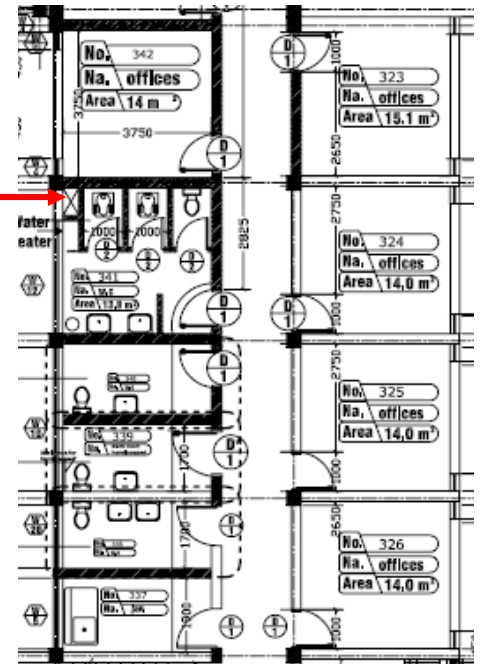

Figure 4. Bathroom section of 2nd story

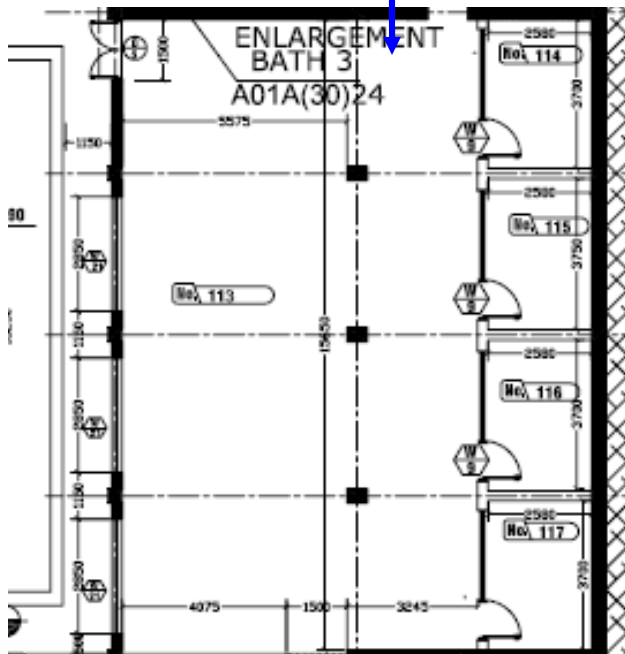

Figure 6. Ground floor Operations Room

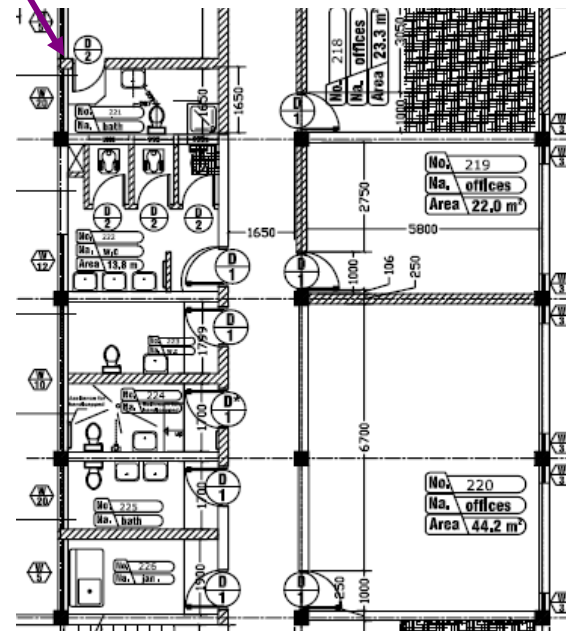
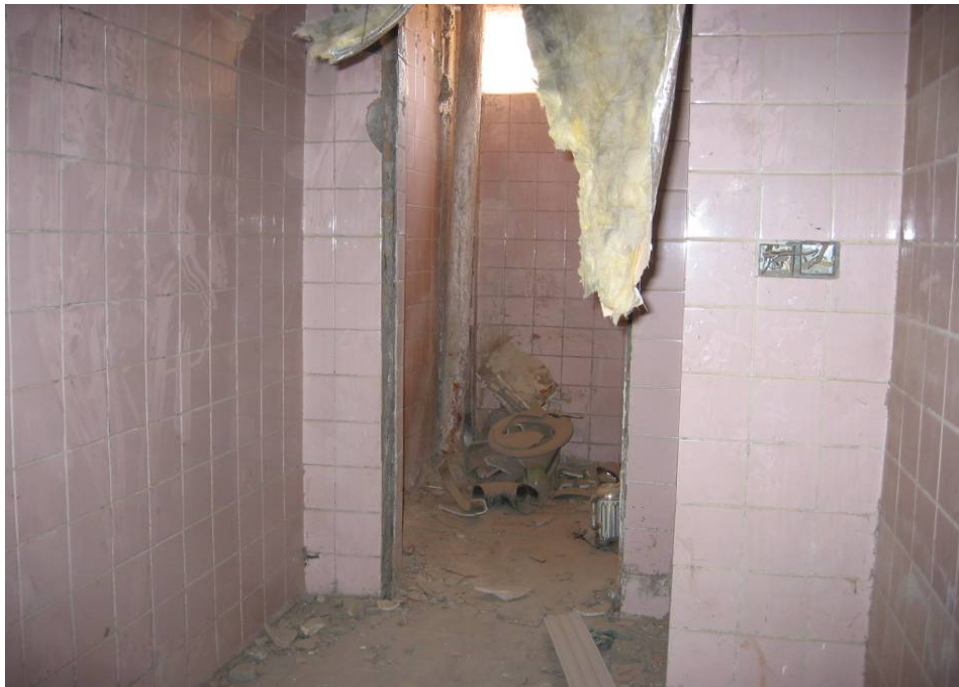

Figure 5. Bathroom section of 1st story



Site Photo 5. Condition of bathroom prior to renovation (Photo courtesy of the USACE)



Site Photo 6. Condition of bathroom prior to renovation (Photo courtesy of the USACE)



**Site Photo 7. Water damage to ceiling of 1st floor bathroom
(Photo courtesy of the USACE)**

**Site Photo 8. Additional view of water damage to ceiling
(Photo courtesy of the USACE)**

IPC Standards

The IPC was designed to provide “minimum standards to safeguard life or limb, health, property and public welfare by regulating and controlling the design, construction, installation, quality of materials, location, operation and maintenance or use of plumbing equipment and systems. Specifically, the IPC code is:

“...founded on principles intended to establish provisions consistent with the scope of plumbing code that adequately protects public health, safety and welfare; provisions that do not unnecessarily increase construction costs; provisions that do not restrict the use of new materials, products or methods of construction; and provisions that do not give preferential treatment to particular types or classes of materials, products or methods of construction.”

In addition, the intent of the IPC is to provide “modern, up-to-date plumbing code addressing the design and installation of plumbing systems through requirements emphasizing performance.”

Cleanouts

Section 708 of the IPC requires the use of cleanouts. A cleanout is a soil pipe fitting and associated piping connected to a building sewer or lateral sewer line. Cleanouts provide access to the soil pipe to unclog and/or remove substances preventing the flow. This feature for soil pipe facilitates normal maintenance and diagnosis of problems and helps to prevent extensive and unwarranted repair. According to IPC Section 708.3.5, cleanouts “shall be installed at each change of direction of the building drain or horizontal waste or soil lines greater than 45 degrees.”

The contractor did not provide the required cleanouts for soil pipe at multiple locations of the ICD HQ buildings. For example, each toilet and shower required the use of a cleanout since the drains connected to the sewer lines at a change in direction. In addition, there are no traps installed for the shower soil pipes. Without the required

cleanouts or traps for the toilets and when soil pipes change directions, solid waste is very likely to collect and ultimately clog the pipes, resulting in backup of the waste water and an unpleasant odor. However, GRD representatives stated that cleanouts are not required for each sink, toilet, and shower because backups can be fixed with the “use of snakes.” While the use of snakes may be effective in clearing out some backups, it will have significant limitations. For example, a snake will only reach so far into a pipe and will often only push the substance clogging the line further down the pipe. At some point, the snake will not be able to reach far enough to continue clearing the pipe (Site Photo 9). Further, GRD representatives previously stated at another project site that Iraqis do not use snakes to clear drains and/or pipes.

In addition, GRD representatives stated that having a single cleanout at the end of a straight run of soil pipe was adequate. However, we identified instances where the subcontractor used poor installation techniques for the single cleanout (Site Photo 10). The top has been cemented and will not come off to allow access to the cleanout, which rendered this cleanout useless for any type of maintenance and/or repair purposes.

As a result of not complying with the IPC requirement, the ICD HQ will be faced with a continual maintenance problem, including the backup and overflow of waste water onto the floor. Without a cleanout, the only method to unclog the pipe would be to completely disassemble it.

The as-built drawings for the ICD HQ bathrooms indicate cleanouts were only used at the far end of a straight run of soil pipe, not for every toilet trap and change of direction (Figure 7). Since the 30% and 60% design drawings were unavailable for our review, we cannot determine whether the government engineers reviewing the bathroom design drawings failed to detect and identify the lack of sufficient number of cleanouts and traps at the correct locations. However, the government design reviews do not mention the absence of cleanouts and traps at the correct locations as a deficiency.

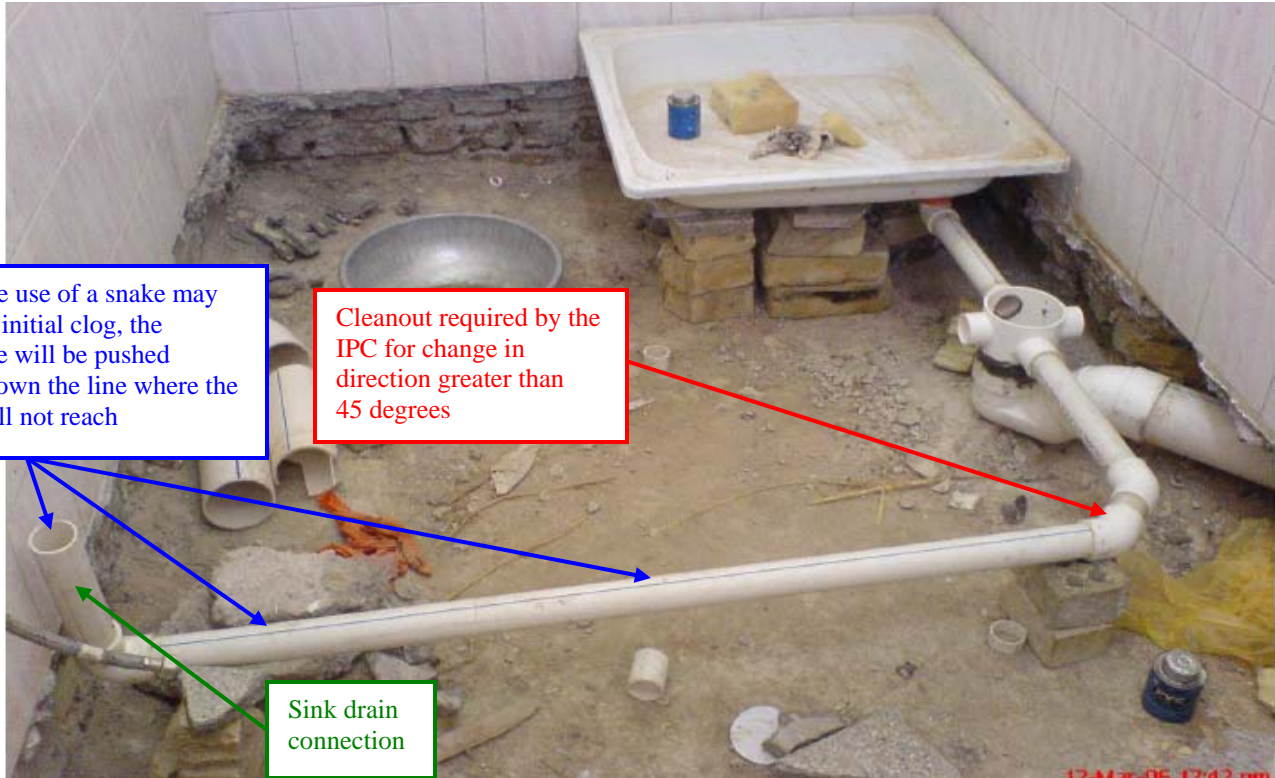

Site Photo 9. Plumbing installation techniques used by the subcontractor – specifically, a lack of required cleanouts (Photo courtesy of the USACE)



Site Photo 10. Cleanout at the end of a straight lateral run of 6-inch sewer pipe. Poor installation resulted in the cleanout being unusable.

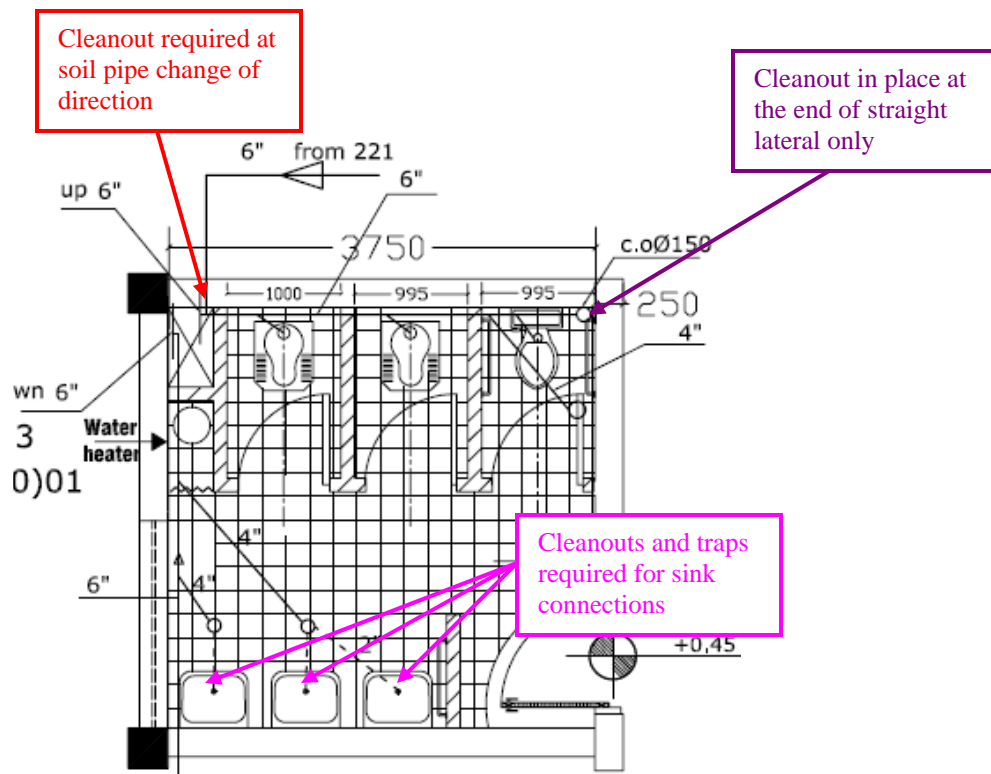

Figure 7. Contractor as-built drawing for ICD HQ building A bathroom

Cemented Joints

It appears that the contractor did not always comply with IPC code Section 707, which specifically prohibits the embedding of plumbing pipes in cement or concrete to seal them in lieu of Polyvinyl Chloride (PVC) bonding compound to seal plumbing joints. Since all of the plumbing pipes had been buried in concrete prior to our site visits, we were unable to visually determine whether the subcontractor had cemented the joints; however, a review of the daily QA reports appeared to confirm that this subcontractor did not always use PVC bonding compound to seal plumbing joints (Site Photos 11 and 12). The daily QA report stated the bathroom pipes had been installed and were ready for testing. Our review of Site Photo 11 indicated that some pipe connections were joined with an unknown bonding material; while other pipe connections do not appear to be bonded together with any type of material. The manufacturer recommended bonding material is critical to ensure water tight joint connections.

In addition to cementing the joints, the subcontractors buried the sewer pipes under the cement floor. Any leak from a joint or crack allows water to leave the pipe and migrate into the available cracks and voids within a raised concrete floor. Since PVC pipe material cannot bond with concrete, water and moisture migrate along the outer surface of the pipes. This practice not only significantly increases the weight of each floor of the building; it also places additional weight upon the unsupported segments of PVC plumbing pipe and undue stress of joints – both lead to increasing the risk of joint cracks and leaks. The construction methods and techniques used are antiquated and grossly inefficient. This type of construction does not offer the opportunity for routine maintenance or for repairs to the plumbing system without significant and major demolition. For example, any sewer line leak that develops would require the entire floor

be dug up in order to identify and correct the source. The subcontractor experienced this problem in March 2006 when significant leaks from the original bathroom plumbing were identified. The subcontractor had no alternative but to completely demolish the bathroom floors to locate, identify, and replace the faulty plumbing (Site Photo 13). Site Photo 13 also shows that the subcontractor used full and partial bricks as aggregate within the cement mix for the raised floor.

Finally, Site Photo 11 illustrates another design and installation problem with the bathroom plumbing. The photo shows a 2-inch sink drain pipe, which needs to make 6 turns in order to flow into the main 6-inch sewer line. These unnecessary numbers of connections exponentially increases the chances of sentiment clogs and leaks.

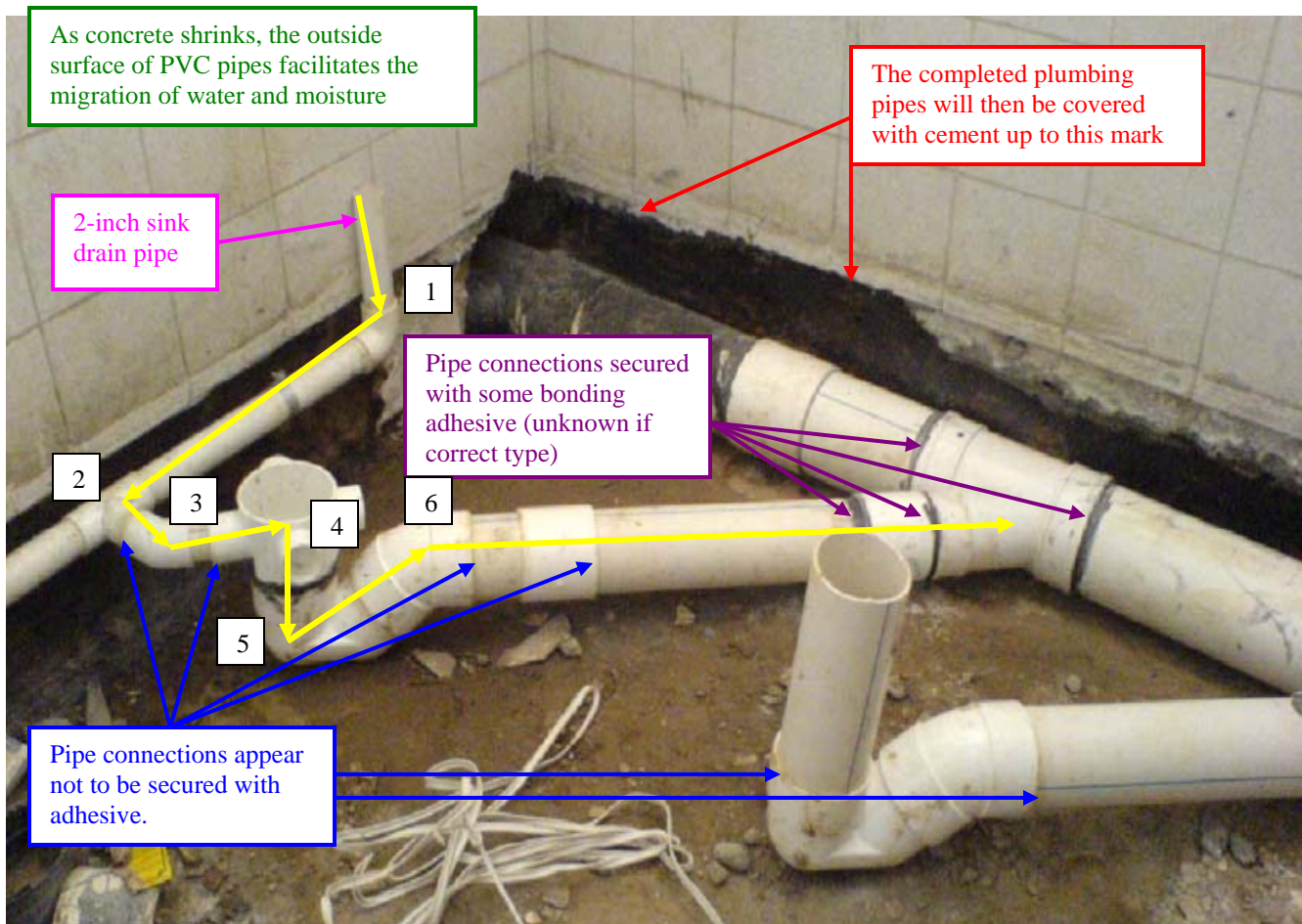

Site Photo 11. Subcontractor's bathroom plumbing assembly prior to pouring cement (Photo courtesy of the USACE)



Site Photo 12. Bathroom after concrete has been poured and tile being applied (Photo courtesy of the USACE)



Site Photo 13. Burying the plumbing pipes required demolishing the floor to correct poor installation techniques (Photo courtesy of the USACE)

Protection of Components of the Plumbing System

Section 305.9 of the IPC states:

“Components of a plumbing system installed along alleyways, driveways, parking garages or other locations exposed to damage shall be recessed into the wall or otherwise protected in an approved manner.”

We identified approximately 15 feet of exposed plumbing sewer pipes leading from the ground floor bathroom to the outside manhole (Site Photos 14 and 15). The exposed sewer pipes are not protected. For example, the sidewalk shown in Site Photo 15 is less than five feet from the entrance/exit of the Operations Room. Any ICD HQ personnel not paying attention may trip over the exposed pipe, resulting in potential injury or breaking the pipe. In addition, PVC pipe is not designed to withstand excessive temperatures and the typical Iraqi summer will eventually cause the pipes to crack. Broken and/or cracked exposed sewer pipes will create environmental and health hazards for the ICD HQ personnel.

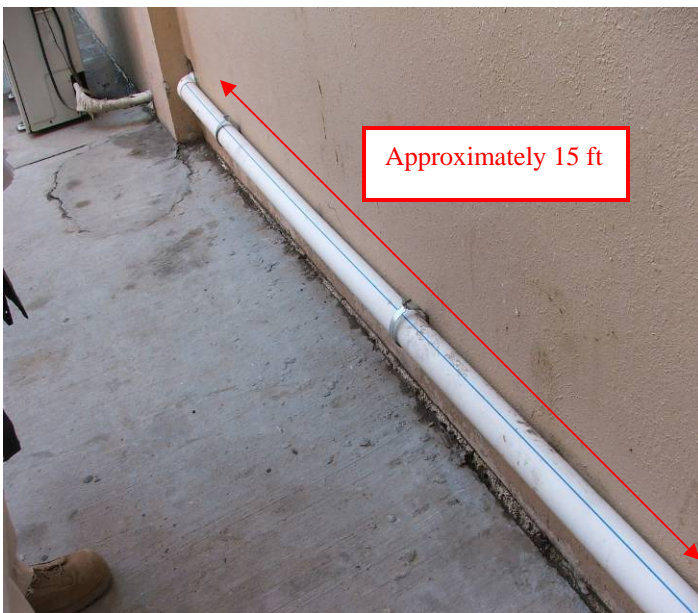

Site Photo 14. Exposed PVC plumbing pipe running from ground floor bathroom to sewer manhole

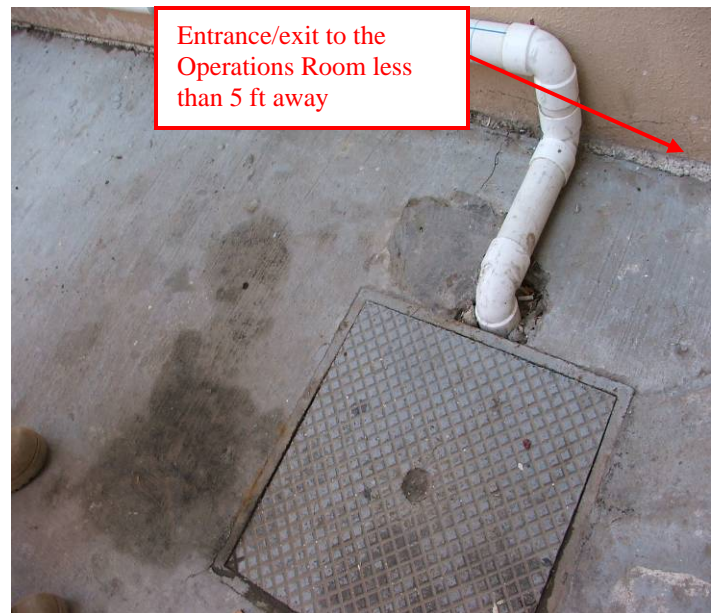

Site Photo 15. Exposed PVC plumbing pipe from ground floor bathroom to the sewer manhole

Inferior Installation Techniques Used

The subcontractor did not always use the proper installation technique, which resulted in water leakage from one floor to the next. Specifically:

- Floor drains are not adequately sealed to the floor surface and/or properly affixed to adjacent fittings with the proper adhesive or sealant, which causes water to drain outside rather than inside the drain collectors (Site Photos 16 and 17).
- Bathroom and janitor rooms were not adequately water proofed.

During our site visit, we lifted a drain cover, which exposed a pooling of sewer water and germs collecting underneath. The contractor did not properly seal the drain cover into the mortar, allowing water to seep underneath, which facilitated the growth of algae. We found cracks, voids, holes, and openings around the drain pipe in the floor. These

conditions allow water to drain outside and travel along the pipe. As a result, the ceiling below this drain will experience significant water damage. In addition, prolonged wet and moist condition with dirt, dust and human body waste will foster the growth of mold, harmful bacteria, unsanitary, and potentially hazardous environmental and health conditions.

The Iraqi practice of cementing around PVC pipe is deficient because cement does not adhere to PVC pipe. Water proofing the bathroom and janitor rooms is crucial for two reasons. First of all, if the sinks and/or toilets leak or overflow, any opening will allow the water an opportunity to penetrate. In addition, the Iraqi custom is to clean bathrooms and janitor rooms by pouring a large amount of water onto the floor and squeegee the water into the drain; therefore, the floors and walls must be water proofed to avoid any leaks seeping into the raised cement floor. During our site visits, we identified examples where the subcontractor's water proofing techniques were substandard (Site Photos 18 and 19). This deficient workmanship will result in water seeping through the openings and damaging the ceiling below.



Site Photo 16. First floor bathroom floor drain

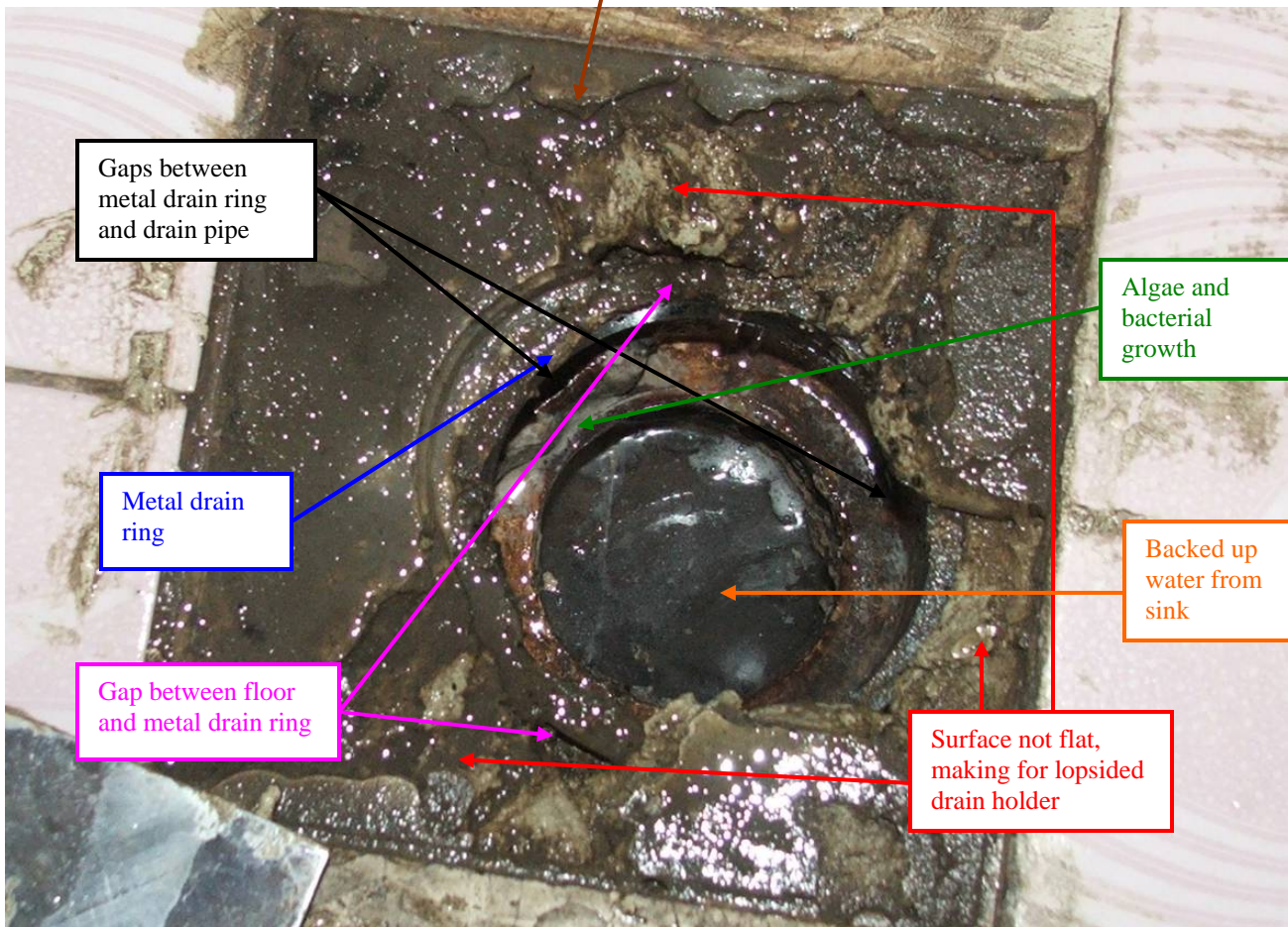

Site Photo 17. Close-up view of first floor drain with cover removed



**Site Photo 18. Poor installation workmanship
(floor not completely waterproofed)**

Gap resulting from cement not adhering to PVC pipe. Water from a leaking sink, overflowing toilet, or for cleaning the floor will run down opening and onto the ceiling of floor below.

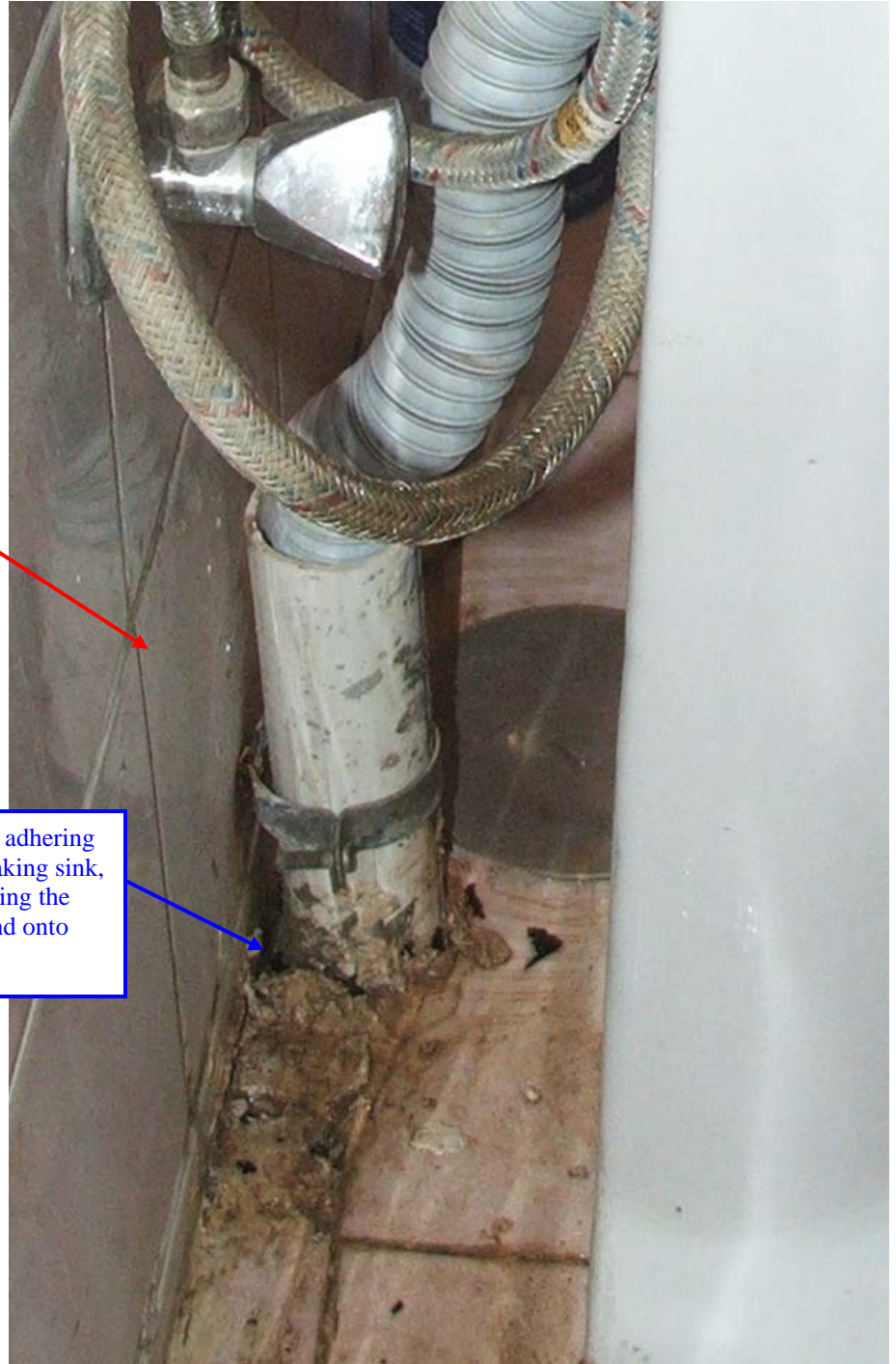

Site Photo 19. Enlarged view of Site Photo 17

Significant Interior Water Damage

On our first site visit, the ICD HQ personnel immediately brought us to the ground floor Operations Room where we identified water damage and staining on the ceiling, walls, and floor of the ground floor (Site Photos 20, 21, and 22). We made return visits to the ICD HQ to determine if the plumbing issues were still unresolved with the GRD and contractor. On our final visit, we identified a significant increase in water damage to the Operations Room (Site Photos 23, 24, and 25).

Cause(s) of Leaking Water

GRC representatives believe the cause of the water damage resulted from work performed by the ICD HQ. Specifically, GRC representatives stated the ICD HQ personnel installed two showers in rooms that were not designed to handle significant amounts of water. The possibility exists that it is water from these showers that is leaking through the floor and running down to the Operations Room. A GRC representative stated she “smelled” the substance on the Operations Room wall and determined it was not sewer water since she “did not smell ammonia.”

However, according to discussions with ICD HQ personnel, the water leaks resulted from poor construction techniques, specifically the subcontractor’s failure to follow the TO required IPC standards. The ICD HQ personnel stated that the dark stain on the pillar is from sewer water, and they are currently dealing with the potential for environmental and health hazards within the room by limiting its use as the designated Operations Room.



Site Photo 20. Water damage in ground floor Operations Room



Site Photo 21. Close up view of water damage on ceiling



Site Photo 22. Water damage on floor of the ground floor Operations Room



Site Photo 23. Water damage within the ground floor Operations Room from our first site visit



Site Photo 24. Additional water damage to ground floor since our first site visit



Site Photo 25. Close-up view of water damage

ICD HQ Installed shower

ICD HQ personnel acknowledge contracting on their own to install two showers, one in a previously existing janitor room and one in a bathroom consisting of a toilet, bidet, and sink. The ICD HQ installed showers do not include shower pans; consequently, the shower water is forced to empty through the floor drain. The shower in the bathroom is on the second floor; while the shower in the janitor's room is on the first floor (Site Photo 26).

GRC representatives assert the water damage inside the ground floor Operations Room and the exterior of the main building is caused by the two showers. Specifically, the shower water splashes onto the wall tiles and directly onto the floor. According to GRC representatives, neither the floors nor the walls in the janitor room and bathrooms are water proofed. As a result, shower water leaked through the wall onto the exterior of the building (Site Photo 26) and through the floor. The design of each floor plumbing system connected the bathroom showers, drains, and toilets lines to the main 6-inch sewer line, which runs horizontally across each floor (Site Photo 26). The main 6-inch sewer line, like the rest of the plumbing, is covered under the raised cement floor. The GRC PE believes the shower water leaked through the second and third floors, traveled from the far side of the ground floor ceiling (near the stairs) across the ceiling to the ground floor Operations Room pillar (Figure 8). The GRC PE's explanation for this occurrence is that the water traveled to the "point of least resistance."

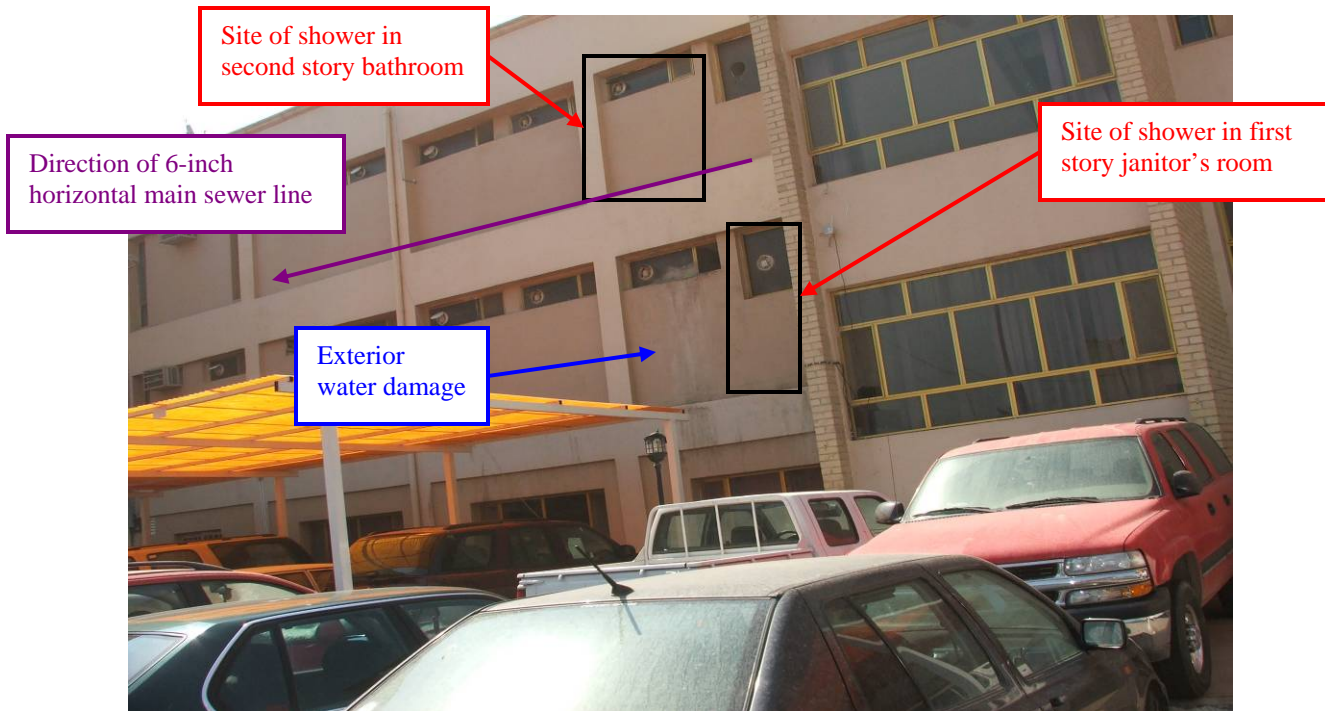

Site Photo 26. Exterior view of the ICD HQ facility

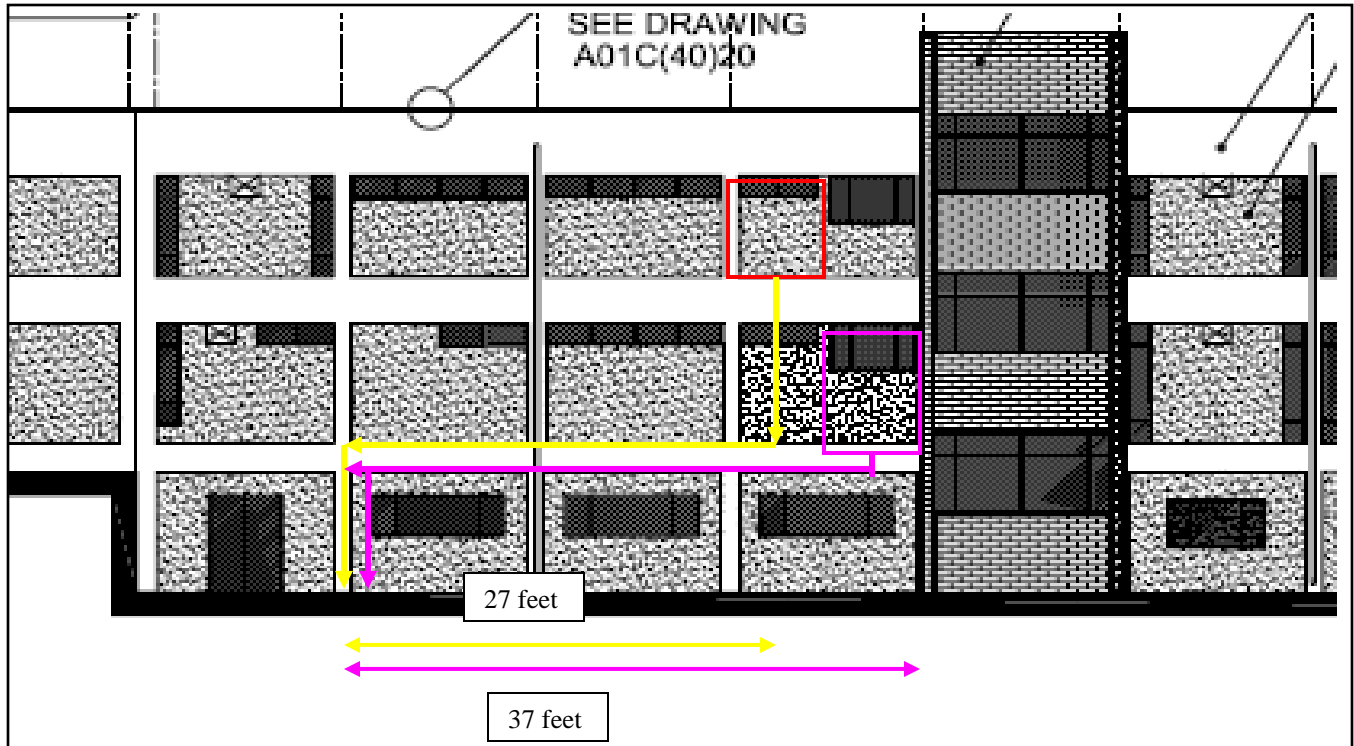

Figure 8. Exterior view of the ICD HQ facility, specifically, the first and second story rooms the GRC PE believes are responsible for the water damage to the ground floor Operations Room

Poor plumbing installation techniques

ICD HQ personnel stated the subcontractor previously failed to adequately and properly install the bathroom plumbing, which resulted in significant water leaks throughout the facility. For example, according to the USACE GRC Quality Assurance Representative (QAR), on 7 March 2006, stated the following:

“All the bathrooms in the first & the second floor in the building (A) have water leak problem, also in building (B) the bathrooms have the same problems, the walls & the ceilings that damaged by the leaks should be treated.”

GRC documentation confirmed that eight bathrooms needed to be redone to correct previously poor plumbing installation responsible for the significant water leak damage; however, GRC representatives were unable to provide documentation that all eight bathrooms were repaired. Instead, the daily QA reports stated the “repair only two bathrooms in the first floor.” It is not known if the subcontractor repaired the two bathrooms directly above the ground floor Operations Room. In addition, ICD HQ personnel contend that the subcontractor did not adequately repair the plumbing problems, which have resulted in damaged ceilings to the bathrooms and the Operations Room.

Determining the actual cause(s) of the water leakage

First of all, the significant water damage to the first floor bathroom ceiling (Site Photos 7 and 8) is the direct result of poor plumbing installation of the second story bathroom directly above it.

Identifying the primary cause of the water leakage into the ground floor Operations Room is difficult because the installed plumbing for the bathrooms directly over the Operations Room are buried in cement. However, during our last site visit, we carefully reviewed the positions of GRC and the ICD HQ representatives to determine the most likely cause of the damage.

GRC's assertion that the ICD HQ installed showers caused the extensive damage in the ground floor Operations Room seemed to us improbable. In order for GRC's theory to be accurate, the second story shower water must leak through both the wall and floor tiles to the ground floor ceiling and then travel across the ceiling approximately 27 feet to the Operations Room pillar. Also, the shower in the first floor janitor's room has to leak through the floor tiles to the ground floor ceiling and then travel across the ceiling approximately 37 feet to the Operations Room pillar. While the building exterior showed prominent signs of water damage, the ceiling in the Operations Room showed little evidence of traveling water leakage (Site Photo 27).

ICD HQ personnel's contention that the subcontractor's poor plumbing installation directly over the ground floor leak caused the extensive damage to the Operations Room is more likely. Located directly above this water damage are two sets of bathroom facilities. The larger of the two facilities consists of 3 toilets, 3 sinks, and two floor drains; while the smaller bathroom consists of one toilet, one sink, and one shower with a pan and floor drain (Figures 9, 10, and 11 and Site Photo 28). These two bathrooms contain a total of 11 water features with intricate plumbing systems connected to a 6-inch lateral PVC pipe. The numerous joints and the installation techniques employed by the subcontractor present multiple opportunities for leaks to occur. In addition, we previously mentioned that the original plumbing installation was poorly done and resulted in water leakage. Any water leakage from either bathroom would deposit water directly below on the Operations Room pillar and beam.

In April 2006, the subcontractor completed the replacement of water damaged plaster on the ground floor Operations Room beam and reworked part of water damaged utility chase in the Operations Room pillar. No photographs of the original water damage to the Operations Room pillar were available, but comparing the area of the repair work to the current water damage, it is almost identical (Site Photos 29 and 30). The caption of the daily report accompanying Site Photo 29 is that:

“Leaks from the first floor bathrooms through the ceiling, the contractor want to repair only this part in the ground floor ceiling.”

During our site visits, we measured the full extent of the water damage to the ground floor Operations Room and first floor bathroom ceilings (Site Photo 31). In both instances, the water damage stops at a location approximately 13 feet perpendicular on the beam surface from the exterior wall, where the 6-inch lateral serving the bathrooms on each floor are located. The design of the first floor bathroom 121 has the shower, toilet, and sink connected via a 4-inch lateral sewer line running from right to left (Figure 12); while the bathroom 119 has three eastern toilets connected through a 4" sewer line also running right to left (Figure 12). The 4-inch lateral sewer line for each bathroom connects to the main 6-inch sewer line in the chase. The distance from both the shower

to the wall and the farthest toilet to the wall is approximately 12 feet. Therefore, the area and location of the water damage to the ground floor Operations Room pillar and beam is almost exactly the same area as the sewer lines directly above in the first floor bathrooms.

Existence of some water damage leading up to the Operations Room pillar; however, there is no visible trail of leaking water (blue line)

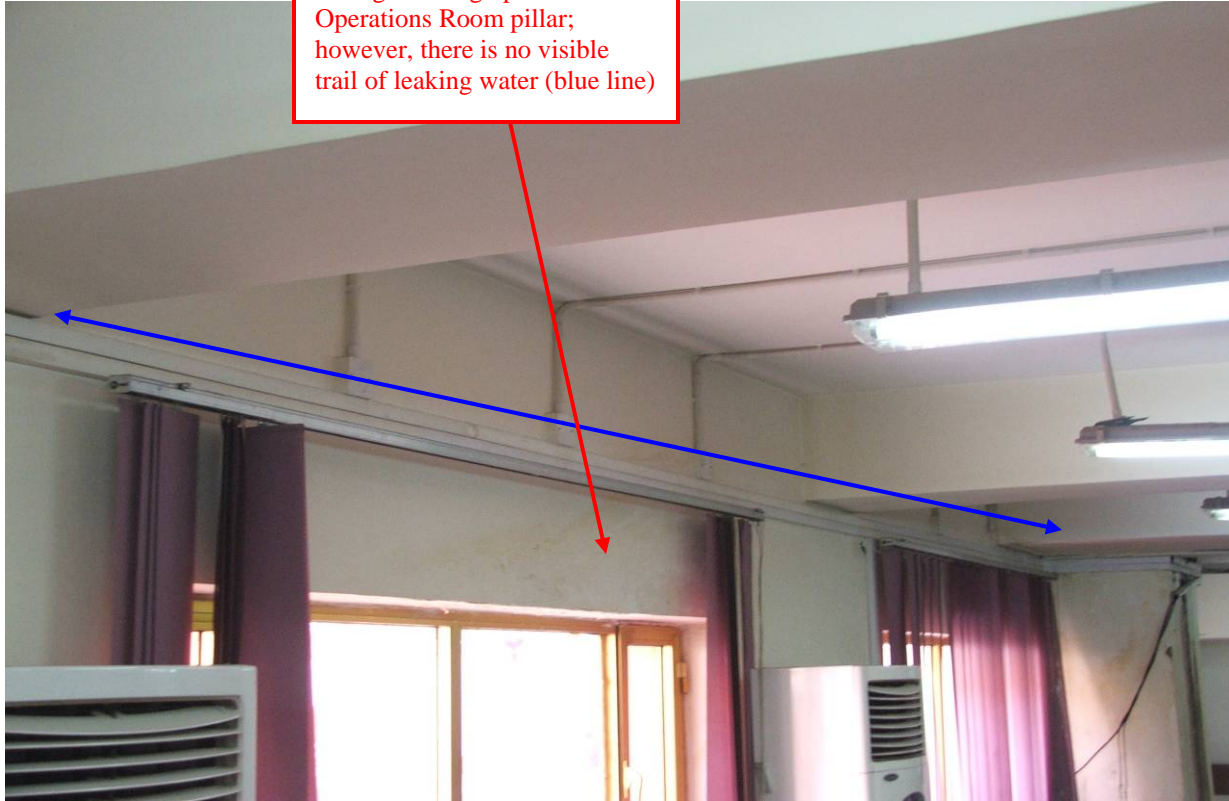

Site Photo 27. View of limited water damage on the ground floor Operations Room ceiling

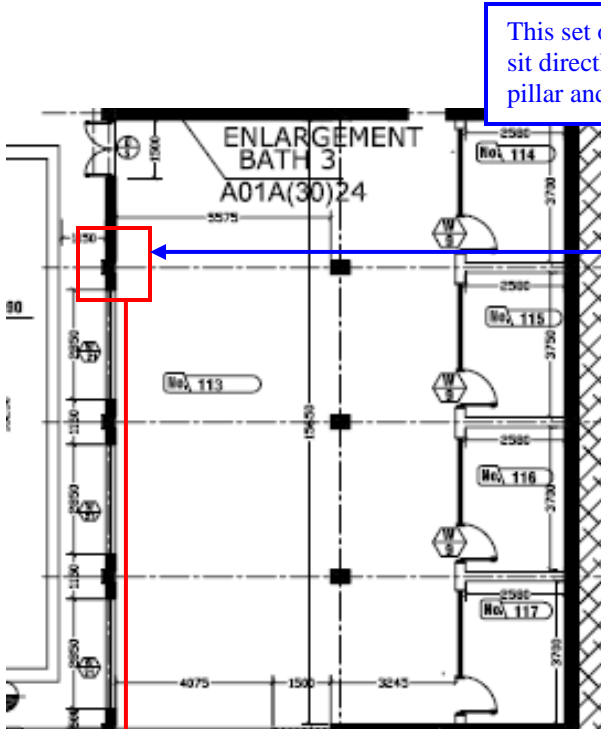

Figure 9. Diagram location of water damage to the ground floor Operations Room

This set of first floor bathrooms sit directly over the damaged pillar and beam

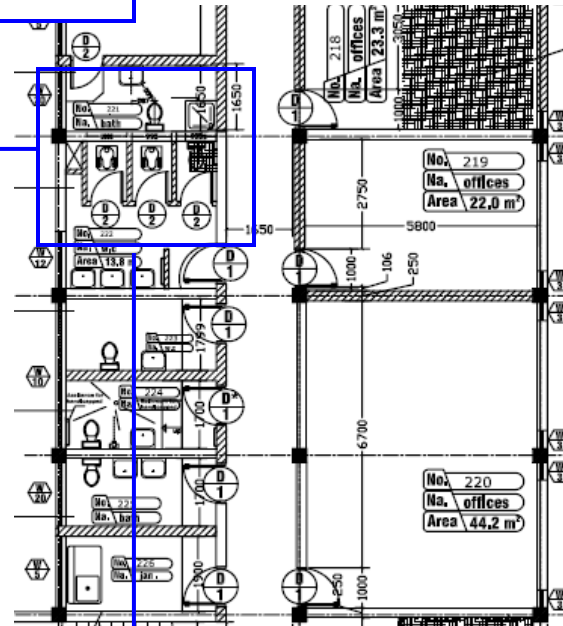

Figure 10. Diagram location of first story bathroom (directly over the damaged wall on the ground floor)



Site Photo 28. End result of poor plumbing installation techniques used in the bathroom directly above this ground floor room

First floor sewer line runs directly above and inside the enclosed pillar

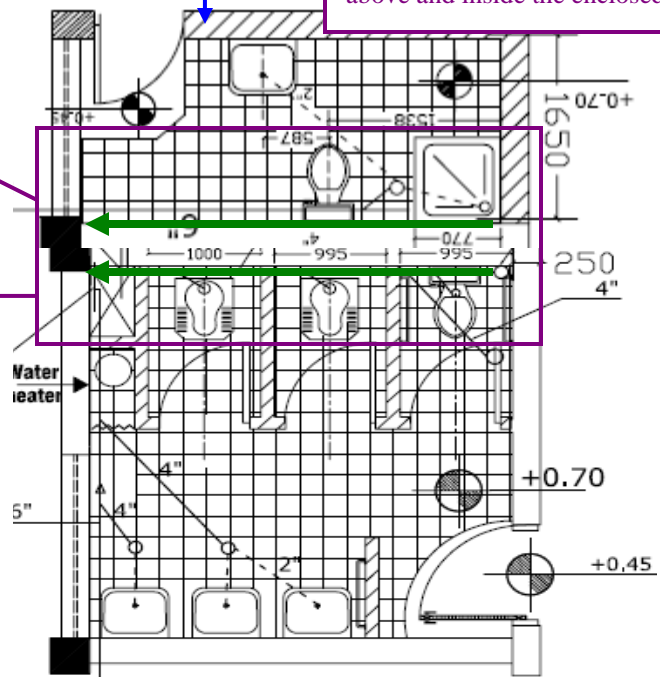

Figure 11. View of bathroom plumbing sewer pipe line (located directly over the ground floor Operations Room)



Site Photo 29. Area of water damage to the ground floor Operations Room replaced by the subcontractor in April 2006 (Photo courtesy of the USACE)



Site Photo 30. Area of water damage almost identical to previous water damage

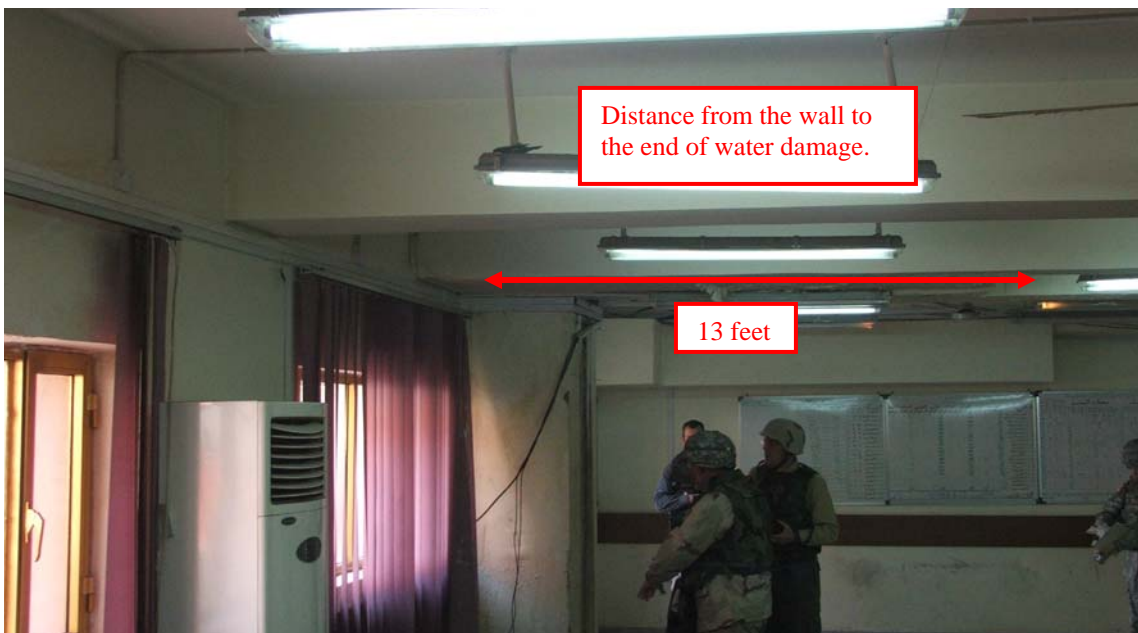

Site Photo 31. Distance from the wall to the end of water damage within the ground floor Operations Room

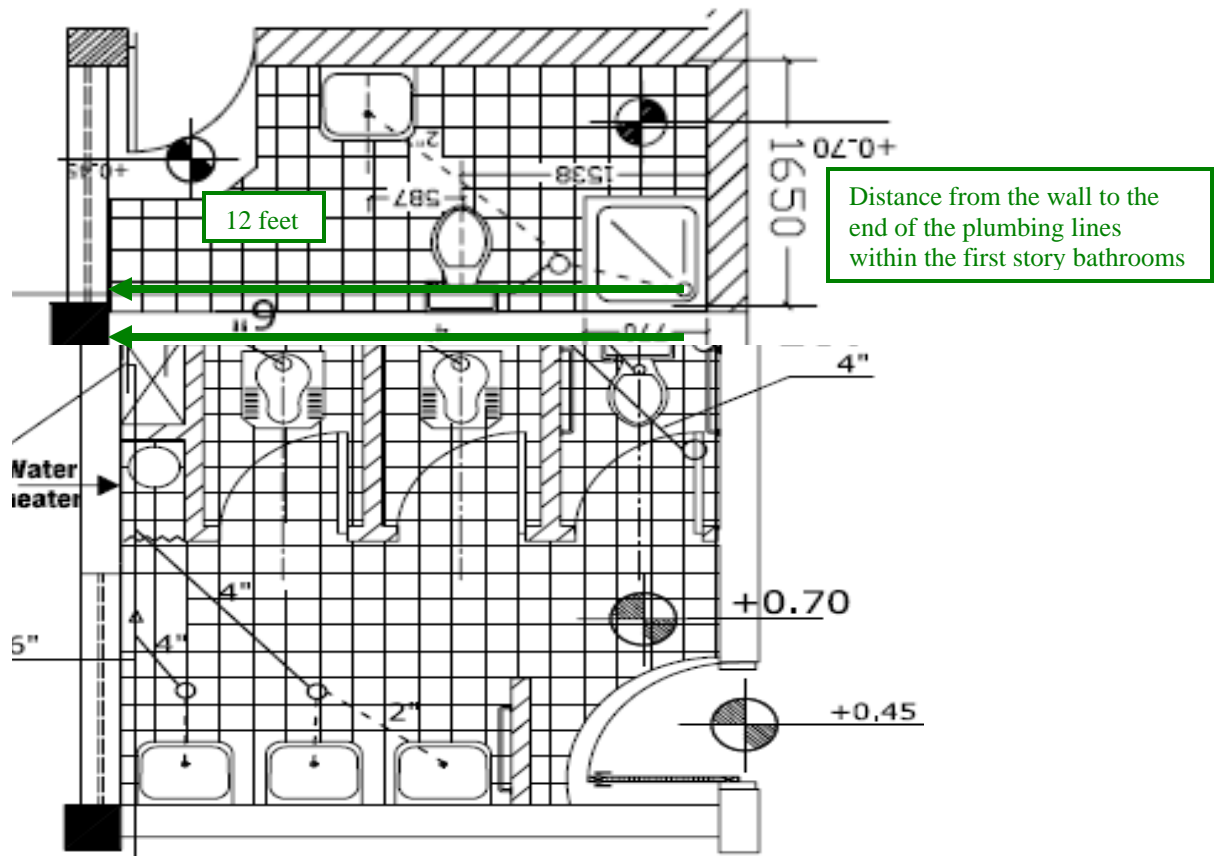

Figure 12. Illustration of plumbing lines, which are located directly above the ground floor water damage

In addition, during our site visits, we identified evidence of water leaks in the first floor chase (Site Photos 32, 33, and 34). The leaks appear at both the ceiling and floor of the chase. The location of the first floor chase is directly on top of the Operations Room pillar. Any water leakage from the first floor chase would drop straight onto the Operations Room pillar and beam.

During our last site visit, evidence of poor plumbing installation were still apparent within the facility, most notably the first floor bathroom ceiling had significant signs of water leakage damage and the floor drain, which was not properly installed (Site Photo 35). This particular drain is directly above the Operations Room beam and there is a noticeable gap between the floor and the metal drain ring. All water on the floor will drain partially down the drain pipe while some water will continually drain outside the pipe and onto the Operations Room beam.

A daily QA report stated that for the bathrooms, a “bitumen & the mastic layers will be spread over the floor & the walls edge as a water proof layer.” However, during our final site visit, the GRC representatives stated the bathroom floors and walls were not waterproofed. The design for the subcontractor installed shower on the first floor consisted of a shower pan (with a drain) but no shower rod to hang a shower curtain in order to keep splashing water from going outside the shower pan. If the bathroom floors and walls are not waterproofed, the subcontractor installed first floor shower, located directly above the Operations Room beam, would result in significant amounts of water splashing onto the walls and the main floor drain. Without any waterproofing of the floor and walls, this water would fall directly onto the Operations Room beam.

Finally, during our last site visit, in an effort to confirm GRC's theory of water leaking from the first and second floors on the left all the way down to the ground floor Operations Room pillar and beam on the right, we thoroughly inspected the ground floor ceiling. We noticed water damage at various points in the Operations Room; however, these water spots appeared to be old and dried out (Site Photos 36 and 37), while water was still dripping from the ceiling slab of the Operations Room (the slab connected to the pillar) (Site Photo 38). This appeared to disprove GRC's theory that water traveled approximately 37' from left to right within the Operations Room. The more likely scenario is the significant water damage resulted from leaks within the two first floor bathrooms directly on top of the Operations Room beam.



Site Photo 32. Water damage within the first floor bathroom chase



Site Photo 33. Close up view of top of Site Photo 32



Site Photo 34. Close up view of bottom of Site Photo 32



Site Photo 35. Poorly installed floor drain in the first floor bathroom



Old water stains

Site Photos 36 and 37. Old and dried out water spots on the ground floor Operations Room ceiling



Site Photo 38. Continuously dripping water on the ground floor Operations Room beam

Additional concerns from water damage

Aside from the potential health and environmental hazards from leaking sewer water, the water is dripping directly on electrical wires (Site Photos 39, 40, and 41). The wires were poorly covered and the constant leaking water has broken off the plastic covering. The live wires are being exposed to water leaking onto them, significantly increasing the risk of electrocution and/or electrical short-circuiting and/or a fire hazard.

In addition, the water leakage is so pervasive that the ground floor tiles in the Operations Room have buckled (Site Photos 42 and 43).



Site Photo 39. Water damage to ground floor Operations Room

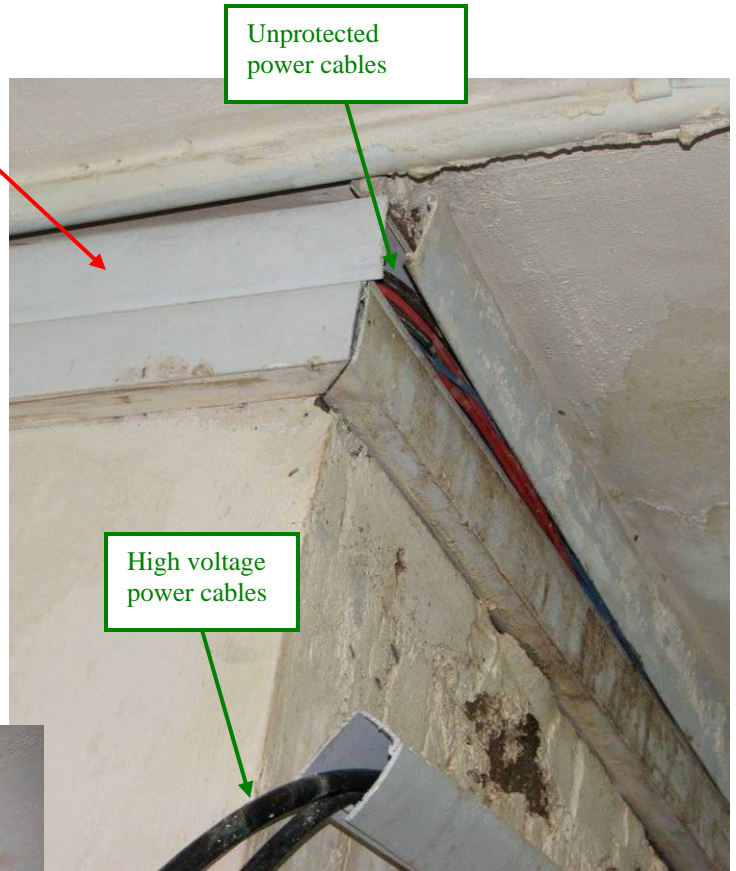

Site Photo 40. Unprotected live wires exposed to leaking water



Site Photo 41. Leaking water on the ceiling and open area of light fixture



Site Photo 42. Tile buckling in the ground floor Operations Room (resulting from pervasive water leakage)



Site Photo 43. Additional view of tile buckling

Lighting, Ceiling Fans, and Outlets

The TO SOW required the installation of new lighting, switched power outlets, and lighting switches. The lighting design was to use energy efficient, low heat producing fixtures so that no more than four different types of bulbs are required. In addition, the TO SOW called for the upgrade of the electrical system; specifically, new electrical power and lighting system to include commercial grade wiring, panels, breakers, switches, outlets, junction boxes, connectors, and fixtures. The TO SOW specifically stated the “design and construction must comply” with the IEC.

Since the ICD HQ buildings were stripped clean of lighting fixtures during the 2003 looting, the contractor needed to install lighting and ceiling fans in each room, which was reflected in Parsons’ as-built drawings. The typical room consisted of four double fluorescent lights (each four feet long) and one ceiling fan (Figure 13).

On our first site visit, ICD HQ personnel immediately brought to our attention electrical fire damage around several fluorescent light fixtures. We identified at least six different locations where electrical fires occurred (Site Photos 44 and 45). The ICD HQ personnel believe the cause of the electrical fires is either a power surge by the transformer or the installation of poor quality fluorescent light fixtures/workmanship.

ICD HQ personnel removed the light fixtures involved in the electrical fires, and in some cases, replaced the light with a new one.

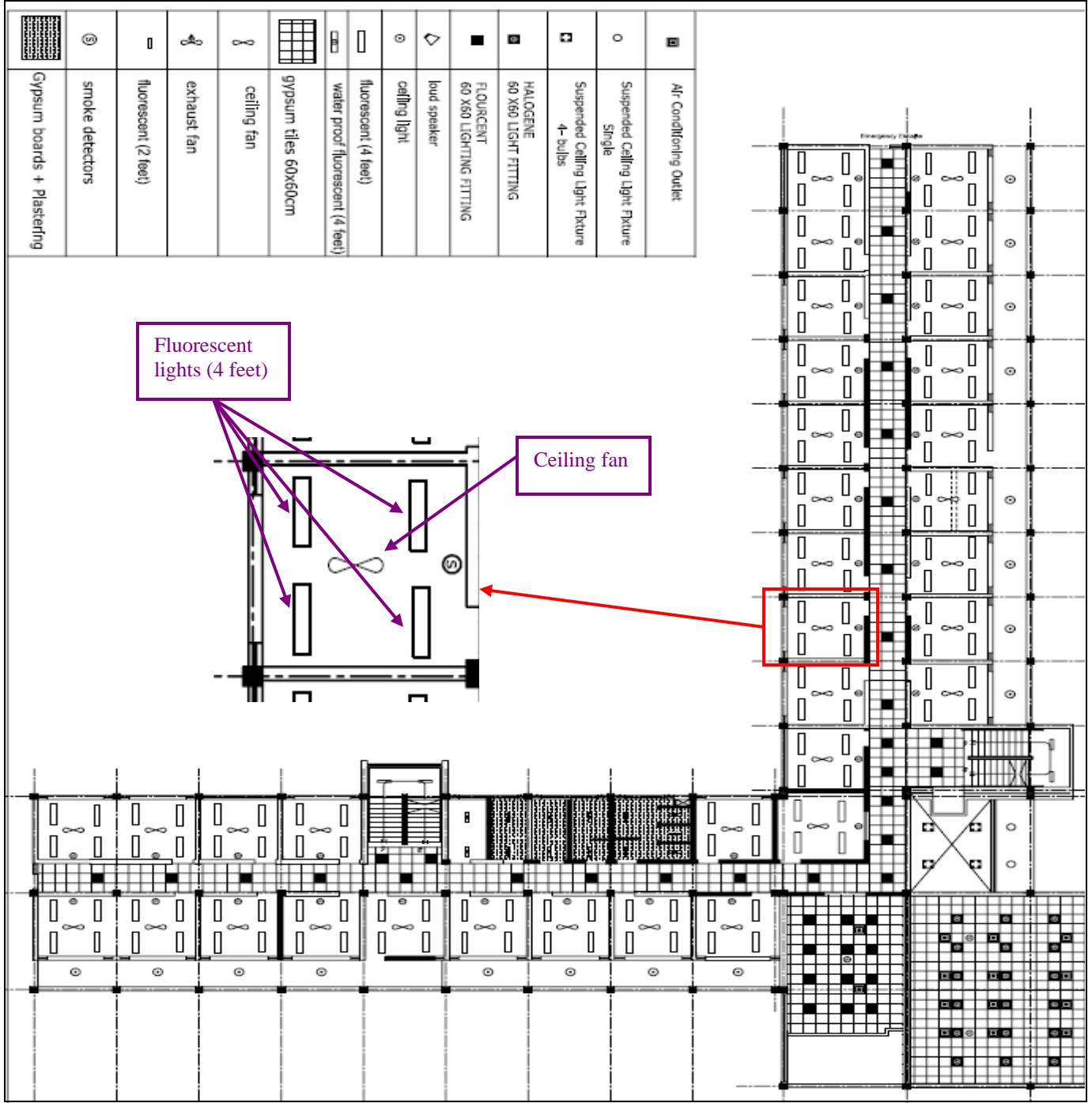

Figure 13. Contractor as-built drawing of the third floor light fixtures



Site Photos 44 and 45. Electrical fire damage around the fluorescent light fixtures

Transformer

The TO SOW required a step-down transformer to interface between the Baghdad City Electrical department incoming high voltage power sources. Parsons provided and connected a transformer to the local grid; however, there is a disagreement between the ICD HQ personnel and Parsons as to whether or not the transformer was “new” or “used.” The ICD HQ personnel believe it is a faulty used transformer because it has a rusted top plate and bolts (Site Photo 46); while a GRD representative stated the reason for the rusted look was the transformer “may have been sitting in a storage lot.” Parsons was to “supply documentation that proves this is a ‘new’ transformer and not a used one.” The only documentation GRC could provide was a letter from Parsons stating a “new transformer was provided.”

The ICD HQ personnel asserted that the faulty transformer resulted in power surges, contributing to the electrical fires. This theory does not appear to be the reason of the electrical fires. The transformer provides electrical power for the entire ICD HQ facilities, including light fixtures, ceiling fans, outlets, and computers. However, the ICD HQ personnel reported no problems with either ceiling fans or computers. Considering the amount of electrical power they draw, power surges would have a significant effect upon computers.

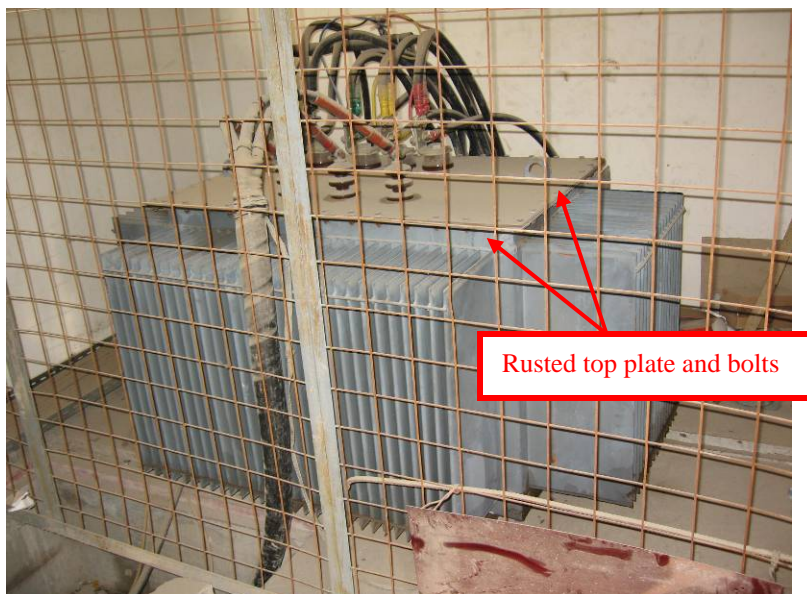

Site Photo 46. ICD HQ personnel believe this is a used transformer because of its used look (rusted top plate and bolts)

Potential Causes of Electrical Fires

According to GRD documentation, electrical fires were recorded as early as November 2005. However, with no design drawing submittals to review, we cannot determine if the electrical design was poor and contributed to the electrical fires by having too much load on one particular breaker. For example, if too many outlets and/or lighting fixtures are on one circuit, the potential for an overload significantly increases, which could lead to an electrical fire.

Further, without dismantling a light fixture for a forensic analysis, we cannot definitively determine if the quality of the subcontractor's work was directly responsible for the electrical fires. However, we observed a sample of the subcontractor's work by lifting up a false ceiling panel in the hallway. The installation work quality appeared to be poor. Specifically, the subcontractor used potentially dangerous installation techniques, such as allowing dangling electrical wiring and placing electrical wires inside unsecured plastic tubing (Site Photos 47 and 48). Finally, the subcontractor also positioned electrical wires carrying various loads dangerously close to each other (Site Photo 49). The subcontractor's carelessness or lack of understanding of electrical standards may have contributed to the electrical fires.

GRD representatives believe a possible cause of the electrical fires is electrical modifications made by ICD HQ personnel to one electrical panel. For example, during our last site visit, GRC representatives pointed out the ground floor electrical panel, which they believe was modified by the ICD HQ personnel (Site Photo 50). GRC representatives stated this electrical panel looks significantly different than other electrical panels installed by the subcontractor. An ICD HQ representative, when asked if any modifications were done to this particular electrical panel, stated he did not know. However, this electrical panel controlled the ground floor electricity, and we did not notice any electrical fires on this floor. The electrical fires occurred primarily on the first and second floors. Therefore, it does not appear that any modifications the ICD HQ may have done to the electrical panel caused the multiple electrical fires.

Without a parts and product submittal package documenting the specific type and design of light fixture, switches, receptacles, fans, wires/conductors, and power panels installed, it is difficult to determine if the lighting fixture directly led to the electrical fires. However, during our last site visit, the GRC PE took two old light fixtures because he remembered a recent U.S. Air Force recall of certain light fixtures. The GRC PE stated he will research the matter further and determine if the subcontractor provided light fixtures were deficient; this would identify the cause of the electrical fires and possibly result in the manufacturer replacing all faulty light fixtures at the ICD HQ facility. If the light fixture is not the cause of the electrical fire, an engineering analysis will be required to determine the root cause of the fires.

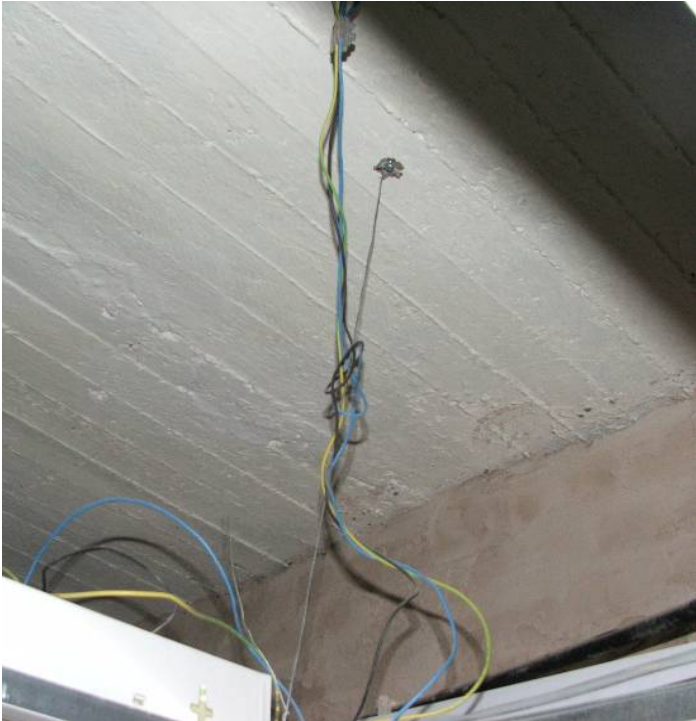

Site Photo 47. Poor electrical installation technique (allowing wires to dangle freely from the ceiling slab)

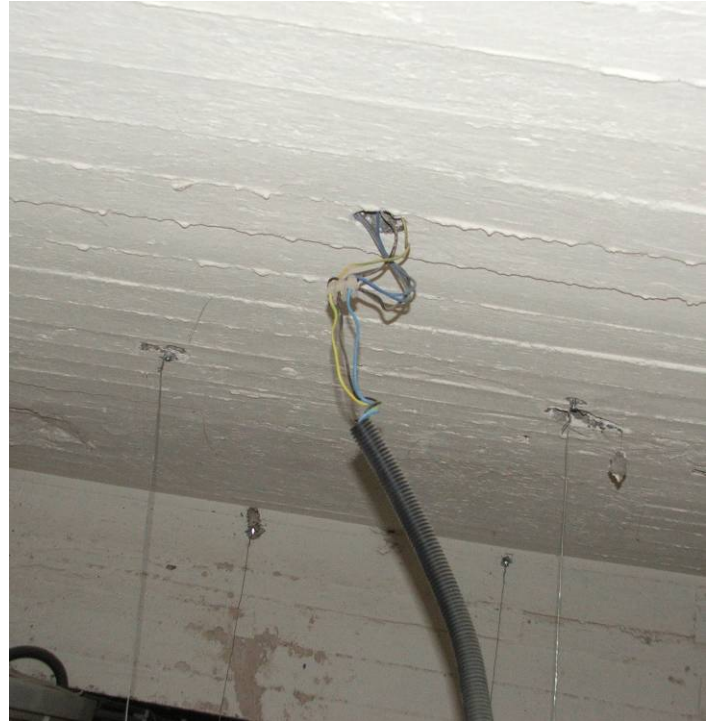

Site Photo 48. Electrical wires within a plastic tube

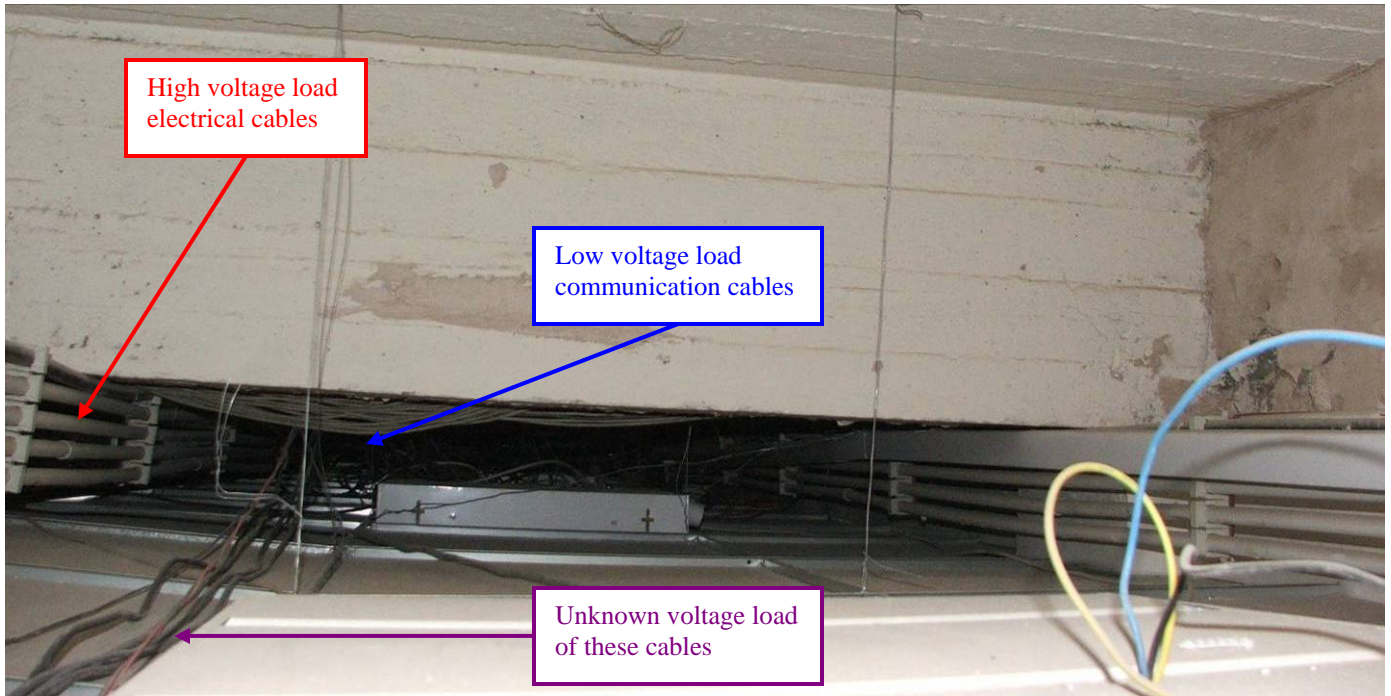

Site Photo 49. Electrical wires carrying varying voltage loads dangerously close to each other

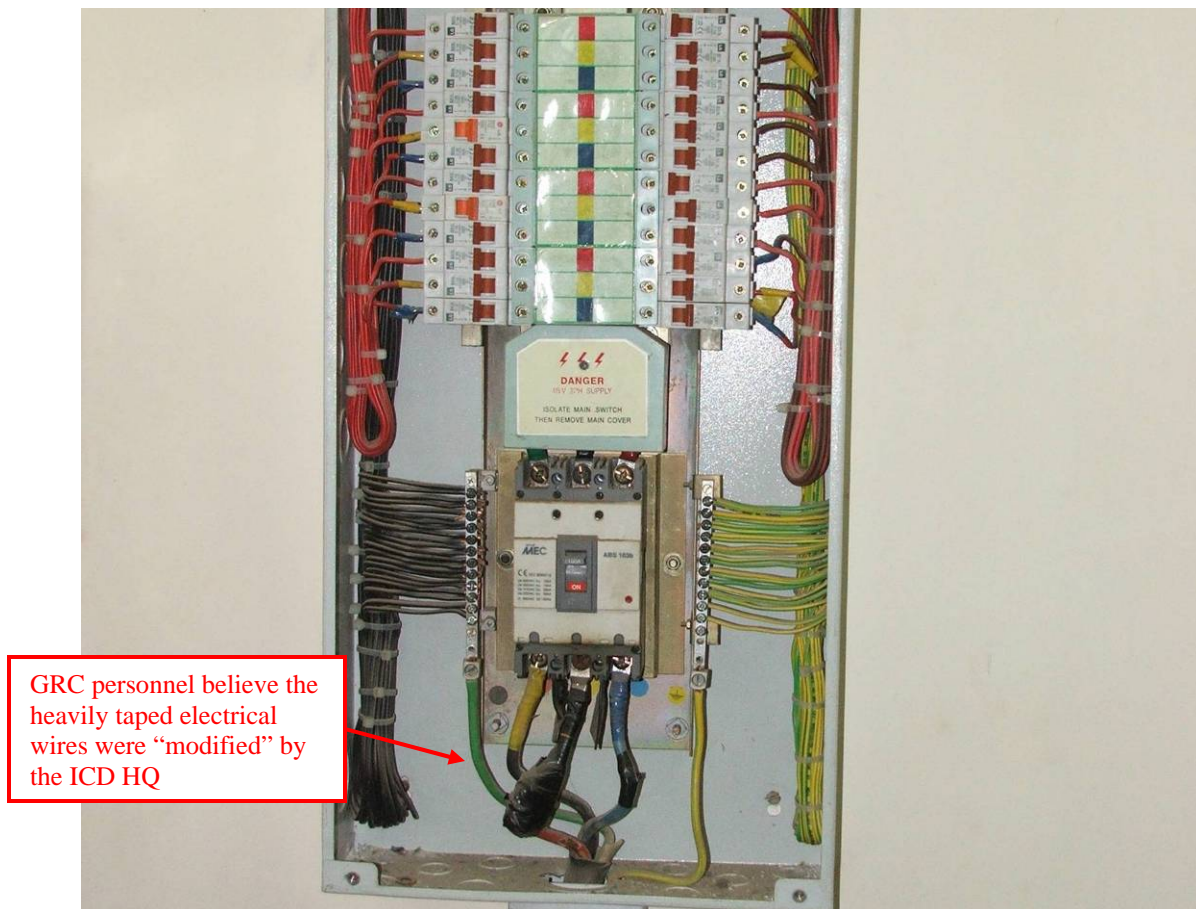

Site Photo 50. Electrical panel GRC believes ICD HQ personnel modified

Generator Power

The TO SOW required the connection of generator power to essential circuits for emergency lighting, essential equipment supporting communications and command center, and life safety systems. Considering the importance of the command and control center for the ICD HQ, it is critical to have essential power available without any lapse. A time-lapse between the loss of primary power from the city's power supply and the power generator picking up the load must be instantaneous. To make this happen, an automatic transfer switch is very important to transfer electrical load from normal power to essential power provided by the standby power generator for the continual function of this command and control location.

During our site visit, we did not see any electrical equipment to facilitate transfer of the power source from the normal city's power grid to the emergency generator. Automatic power source transfer switch and associated assemblies are required for continual operation of this building. In absence of electrical design drawings, we cannot conclude the existence of the required equipment.

The SOW did not specify the size and capabilities of the generator; however, the subcontractor submitted a proposal stating that their electrician's calculations determined that an 800 KVA generator "will be quite enough to regenerate the power for the whole building." The generator model was to be a Cukurova or Aksa, with an automatic change over, and a total cost of \$110,000.

During our site visit, we identified the generator as a Cummins Power Generation, Model Number 651DQCC, manufactured in 2004 (Site Photos 40 and 41). The listed frequency of 50 Hz is the equivalent of 900 KVA. In the absence of test documentation for the generator set, we are unable to determine the adequacy and functionality of this generator set.

The ICD HQ personnel stated the generator overheats after approximately 1-2 hours of normal use. This deficiency has been documented in several punch-list agreements between Parsons and GRD. The ICD HQ attempted to fix the problem by adding an exhaust vent and radiator to the generator to effectively cool the generator (Site Photos 51 and 52). According to ICD HQ personnel, these add-ons have helped marginally, but the generator still has to be shut down because it will overheat. To date, according to ICD HQ personnel, the problem still has not been adequately addressed by Parsons or GRD and the ICD HQ does not have adequate power to operate essential life safety systems.

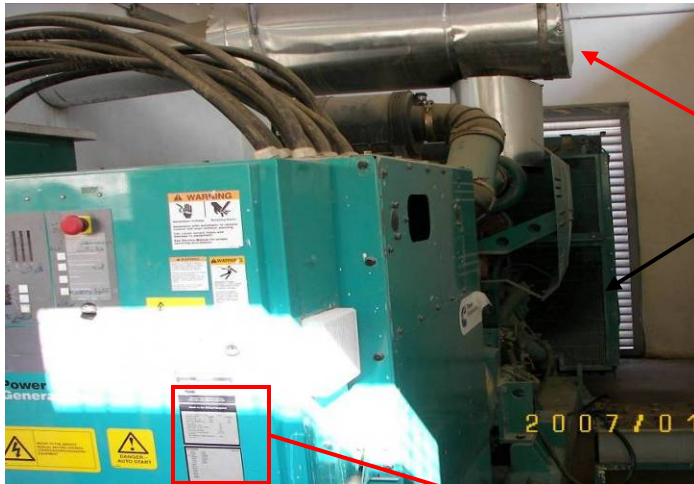

Exhaust system (red arrow) and radiator (black arrow) added to the generator in an effort to cool it down. While this has helped, the generator still suffers from overheating.

Site Photo 51. Generator power for the ICD HQ buildings

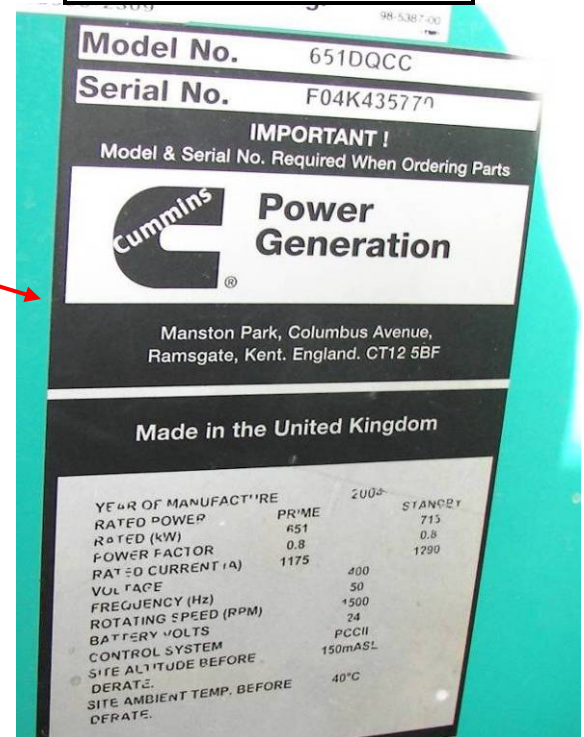

Site Photo 52. Enlargement of generator face plate

Sally Port Gates

The TO SOW required the installation of four remote-controlled anti-explosive armored steel rolling gates. Two gates were to be erected at each of the two Sally Ports of entry within the ICD HQ compound (Figures 14 and 15). The movement of the gate is achieved by two wheels at the bottom of the gate traveling on a track embedded in the pavement. A motor was installed to provide the needed torque to operate the gates.

During our initial site visit, ICD HQ personnel stated the Sally Port gates are not operational. The design for the operation of the gate was not available and the as-built drawings do not include any specifications for the motor. In our opinion, the mechanism to move the gate from one end to the other was not adequately designed and configured. A properly designed steel rolling gate would have included load calculations, such as the weight of the gates while in motion, to determine the correct size motor to operate the gates. In addition, considering the weight of the gate doors, at least four wheels were necessary to move it across the track. The subcontractor provided motor does not have adequate horse power to move the gate; consequently, the motor cannot produce the required torque to operate the gates. In addition, the gates appear to have not been properly treated with a prime coat of paint prior to installation since they had rust spots

and peeling paint. Since the gates were not properly primed or painted, the continual rust will eventually lead to weakening of the gates (Site Photos 53 and 54).

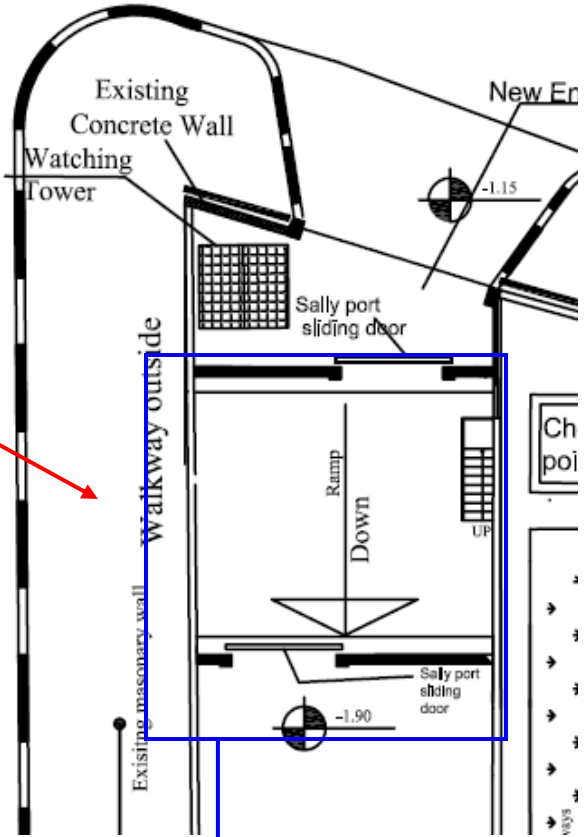
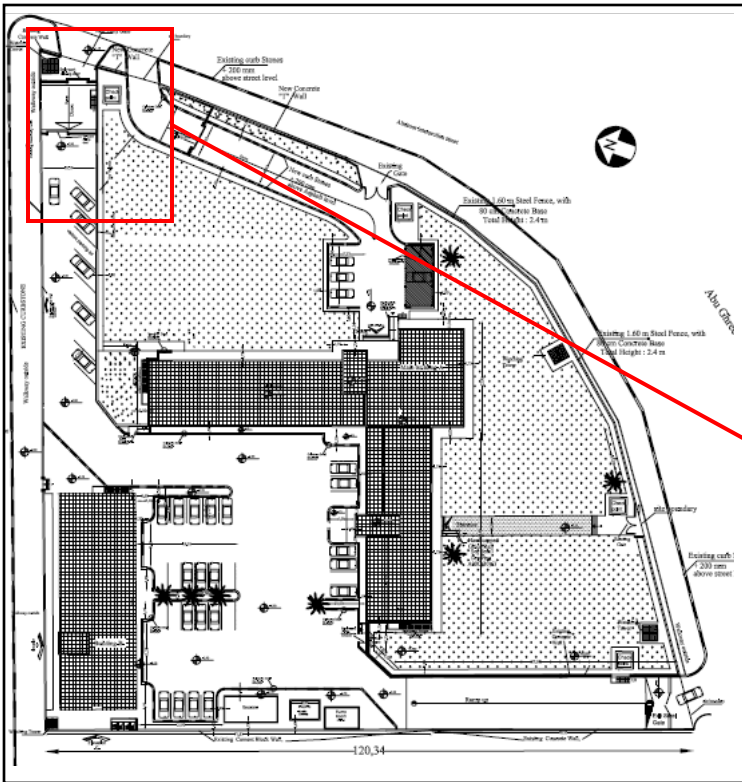

Inadequate size motor – does not produce enough torque to move the gate



Site Photo 53. Enlargement of Sally Port gate motor

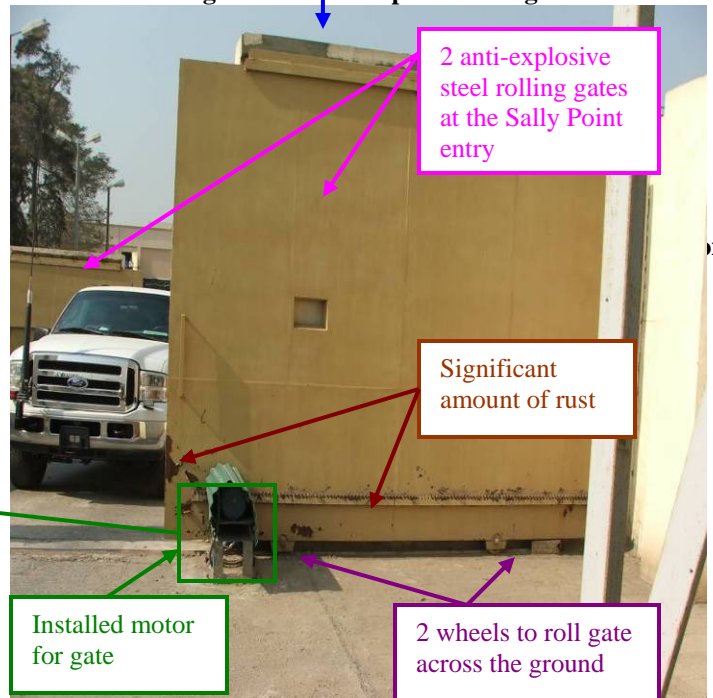

Site Photo 54. Sally Port gate

Another poorly designed aspect of this gate system is that it does not provide any locking mechanism once it reaches the destination point (the other wall). The intent of this gate was to provide explosive-proof security for the ICD HQ compound, which means prohibiting a suspected vehicle from entering the compound. In order to adequately stop the vehicle from entering, the sliding gate has to lock into either the ground or the other wall upon contact. This door does not meet the necessary means to prevent forced entry or provide resistance to an explosion. There are no mechanisms to keep the door in the intended (locked) position (Site Photos 55 and 56).

Since security is of the utmost importance at the ICD HQ and the Sally Port gates failed to provide it, the ICD HQ, at its own expense, installed manually operated security gates at the compound (Site Photo 57).

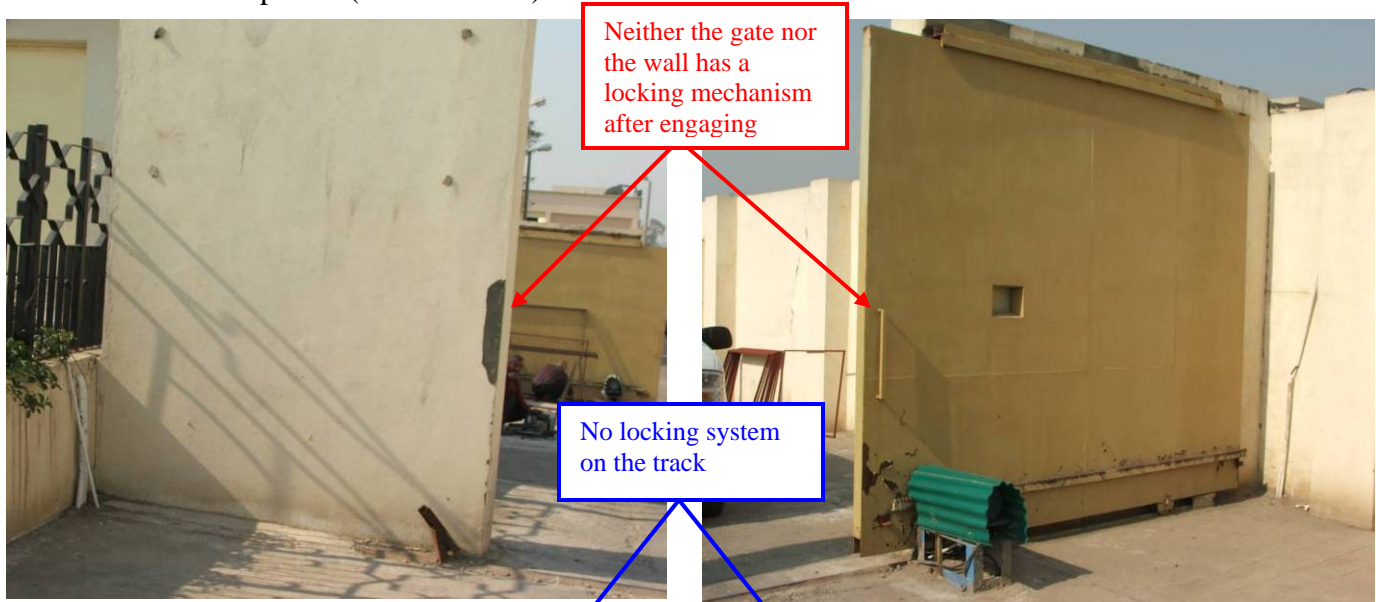

Site Photo 55. Left side of Sally Port gate

Site Photo 56. Right side of Sally Port gate



Site Photo 57. Manual gate installed by the ICD HQ

Test Results and As-Built Drawings

Test Results

As part of its close out documentation, Parsons needed to provide GRD with its testing results. Test results and logs are required for the water and sewer pipes, concrete pours, HVACs, generator, and transformer. This documentation is critical since it confirms the systems were working at the time of turnover to the ICD HQ. The required and customary documentation used to document test results include:

- actual test results and logs
- evidence of test setup
- type of equipment used (i.e. brand name and model number)
- names of the witnesses present

The close-out documentation provided to us by GRD did not contain any test results.

The ICD HQ believes the generator and transformer are both substandard. Test results of both pieces of equipment would indicate whether the subcontractor provided the ICD HQ with quality equipment.

Considering the significant problems the ICD HQ is dealing with concerning the plumbing, generator, and transformer, the test results and logs are crucial in determining whether the issues are subcontractor work deficiencies or ICD HQ maintenance issues.

As-Built Drawings

As-built drawings are a set of drawings which depict the actual as-built conditions of the completed construction. They indicate any construction deviations from original design and show all features of the project as actually built. According to USACE Engineering Regulation (ER) 415-345-38, “customers must have complete, accurate and timely as-built information for proper operations and maintenance, effective warranty enforcement, and future repair and rehabilitation work.”

The as-built drawings do not include any electrical drawings; specifically, there are no electrical line drawings and branch circuit distribution plans. Without this information, the ICD HQ personnel will not know the size of the circuit load and breakers, type, quality, and gauge of wire, as well as load factor for distribution design. This information is critical for proper maintenance and repair of the electrical system.

We mentioned in the Design section of this report that GRD was not satisfied with the quality and accuracy of Parsons’ as-built drawings. In some instances, the as-built drawings do not reflect the reality of the rehabilitation and construction work performed.

Expansion Joints

Specific expansion joint details are critical, since properly designed and correctly installed joint systems are capable of protecting buildings and structures from damage caused by thermal expansion and contraction as well as anticipated foundation movements. Two separate as-built drawings refer to expansion joints – one at the roof and the other at the suspended ceiling (Figures 16 and 17). Yet, the as-built drawings do not reference exactly where on the roof and suspended ceiling the expansion joints are located. In addition, there were no as-built drawings documenting the specification of expansion joints for the each floor and wall of the ICD HQ building or the location of the expansion joints. According to the

“complete” as-built drawings, no expansion joints were used on the floor, wall, or roof of the ICD HQ building. However, both GRD and ICD HQ personnel stated that at least one expansion joint was installed on the exterior wall of the ICD HQ building (Site Photo 58). The location of this expansion joint is questionable because it does not appear to be in the correct spot (Figure 18). Further, the installation of the expansion joint does not appear to be done correctly (Site Photo 59). The intent of an expansion joint is to allow a building to withstand thermal expansion and contraction and foundation movements; however, the fact that the subcontractor put plaster on top of the expansion joint negates its effectiveness.

We found no evidence of the installation of any type of expansion joint system at any location in this building.

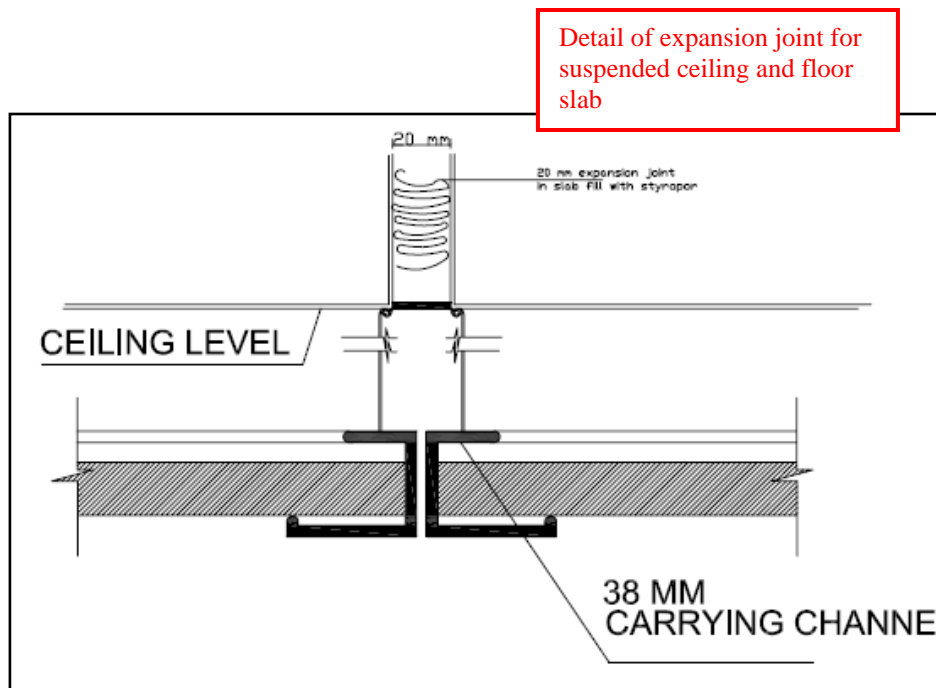

Figure 16. Contractor’s as-built drawing for expansion joint for ceiling and floor slab

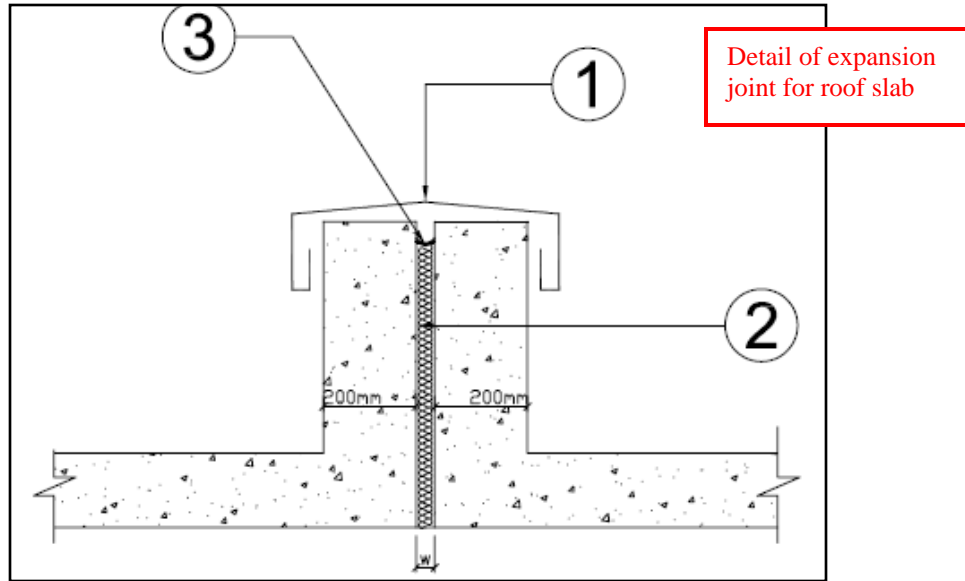

Figure 17. Contractor's as-built drawing for expansion joint for roof slab



Site Photo 58. Location of the expansion joint



Site Photo 59. Enlarged view of expansion joint material

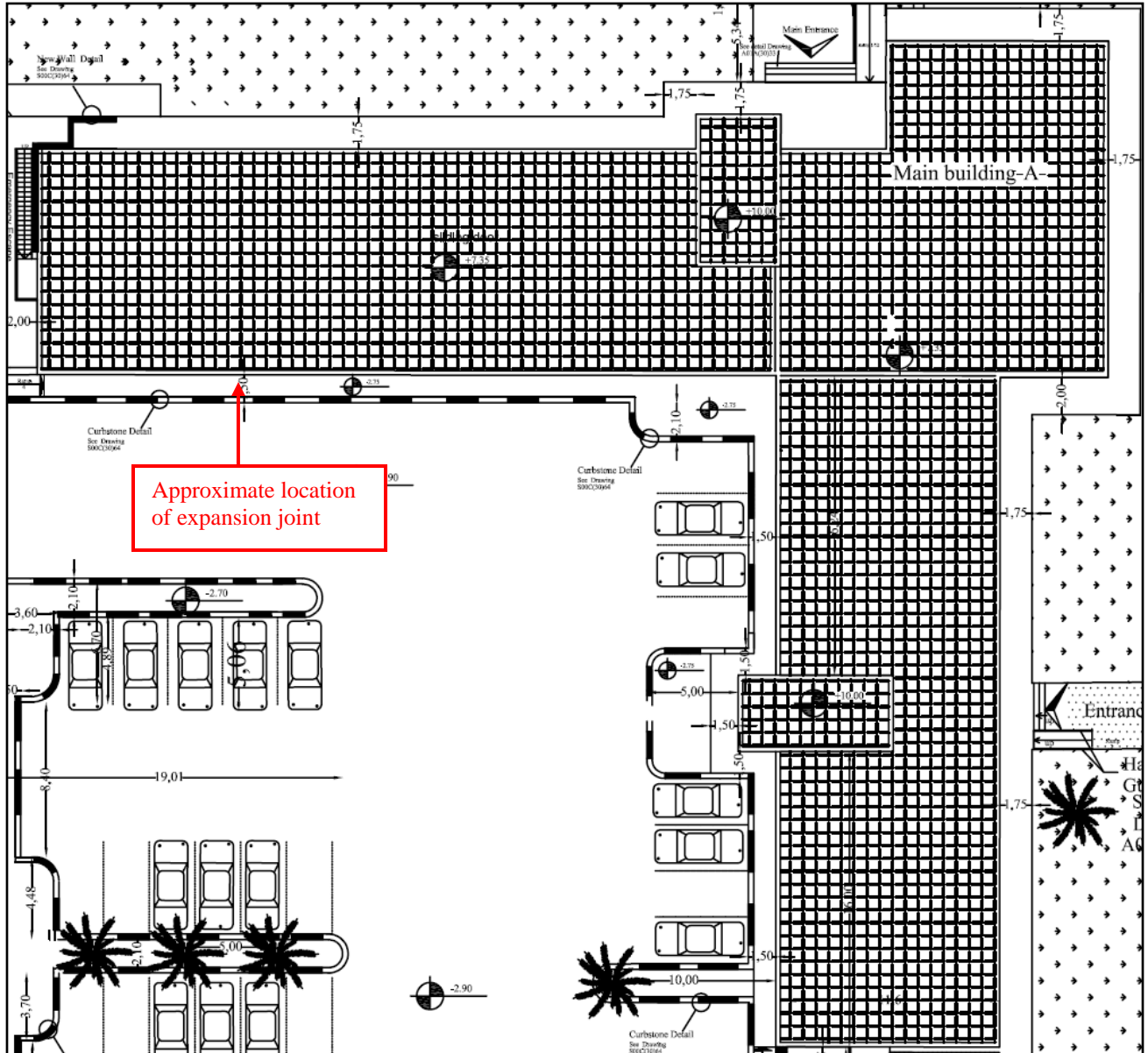

Figure 18. According to GRD and ICD HQ personnel, the location of the expansion joint at the compound

Sally Port Sliding Gate

The as-built drawings for the Sally Port sliding gate indicate that each gate has four rollers/wheels and one vision hole (Figure 19). However, during our site visits, we identified that each gate had only two rollers/wheels and at least one gate had no vision hole (Site Photo 60). The lack of two additional rollers means the weight of the anti-explosive gate is distributed over two fewer wheels, resulting in additional stress on the two rollers. The vision hole is critical to enable the sliding gate guard to identify those attempting to enter the ICD HQ compound. Without a vision hole, the guard will have to partially open the sliding door in order to identify anyone approaching; this significantly increases the danger to the guard and the compound.

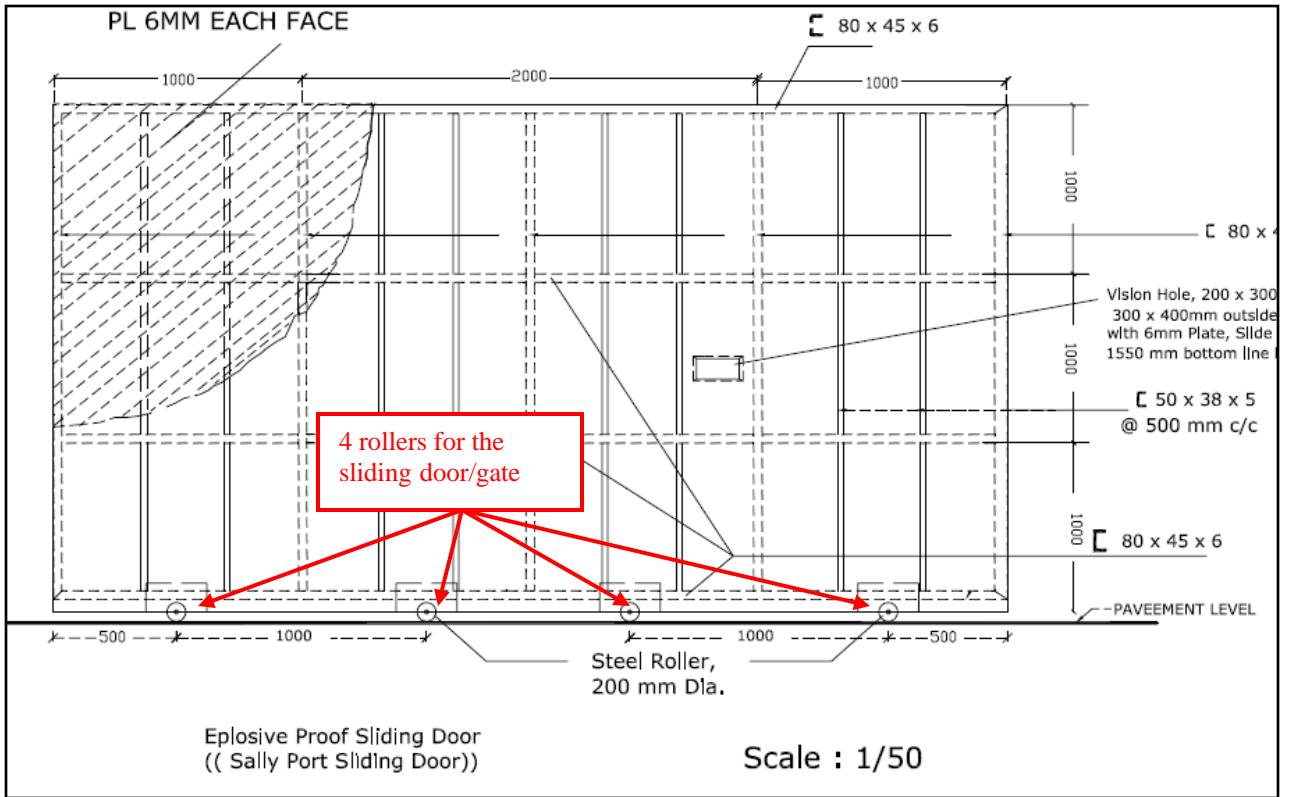
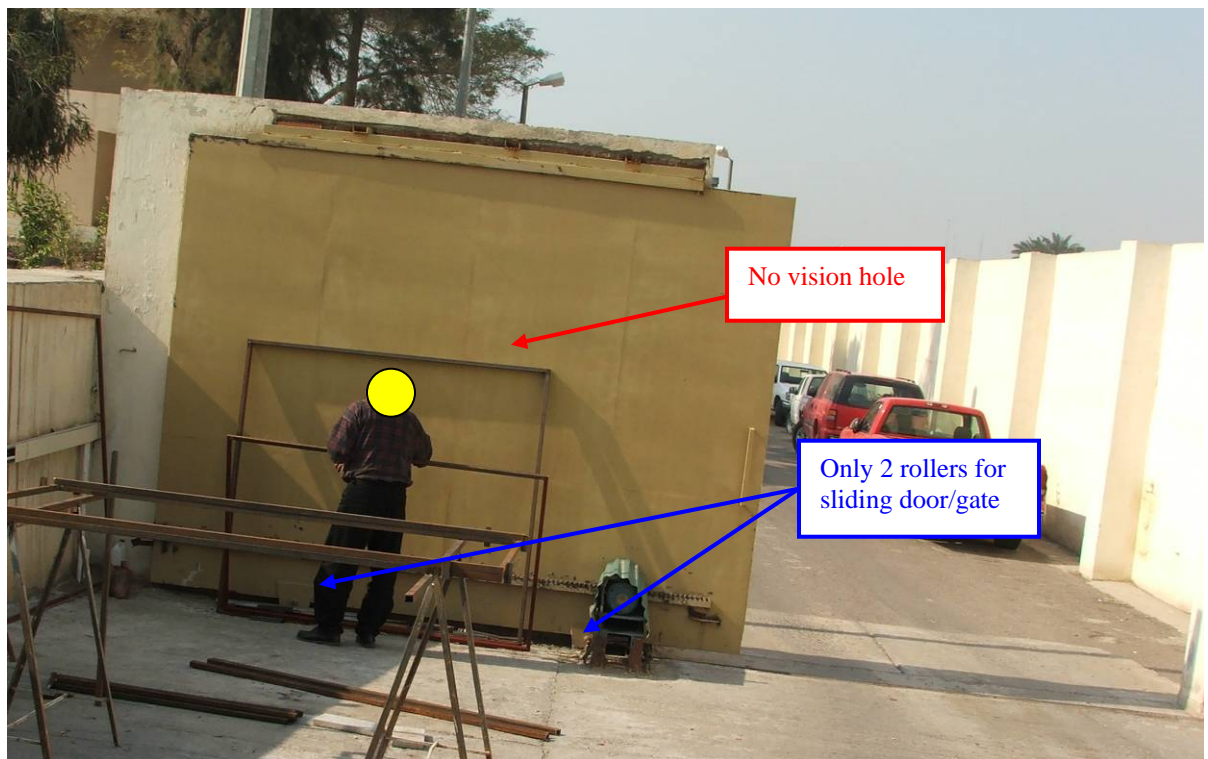

Figure 19. Sliding door fabrication detail (from as-built drawings)



Site Photo 60. Sally Port gate and motor

Sewage Lines

The sewage line site plan as-built drawings for the ICD HQ main building does not provide a correct sewage flow diagram (Figure 20). For example, in one instance sewage appears to flow in opposite directions (Figure 21), which is not possible considering the sewage lines run directionally by gravity. We lifted the manhole cover (Site Photos 61 and 62) and determined that the sewage actually flowed from Box 4 to Box 3. In another instance, the direction of the sewage flow is not correct. Figure 21 shows sewage directional flow running from Box 4 to the left toward Box 5; however, when we lifted the manhole cover, we determined the flow of the sewage line was running from Box 5 to the right to Box 4 and then downward to Box 3 (Figure 22 shows the correct directional flow of sewage lines).

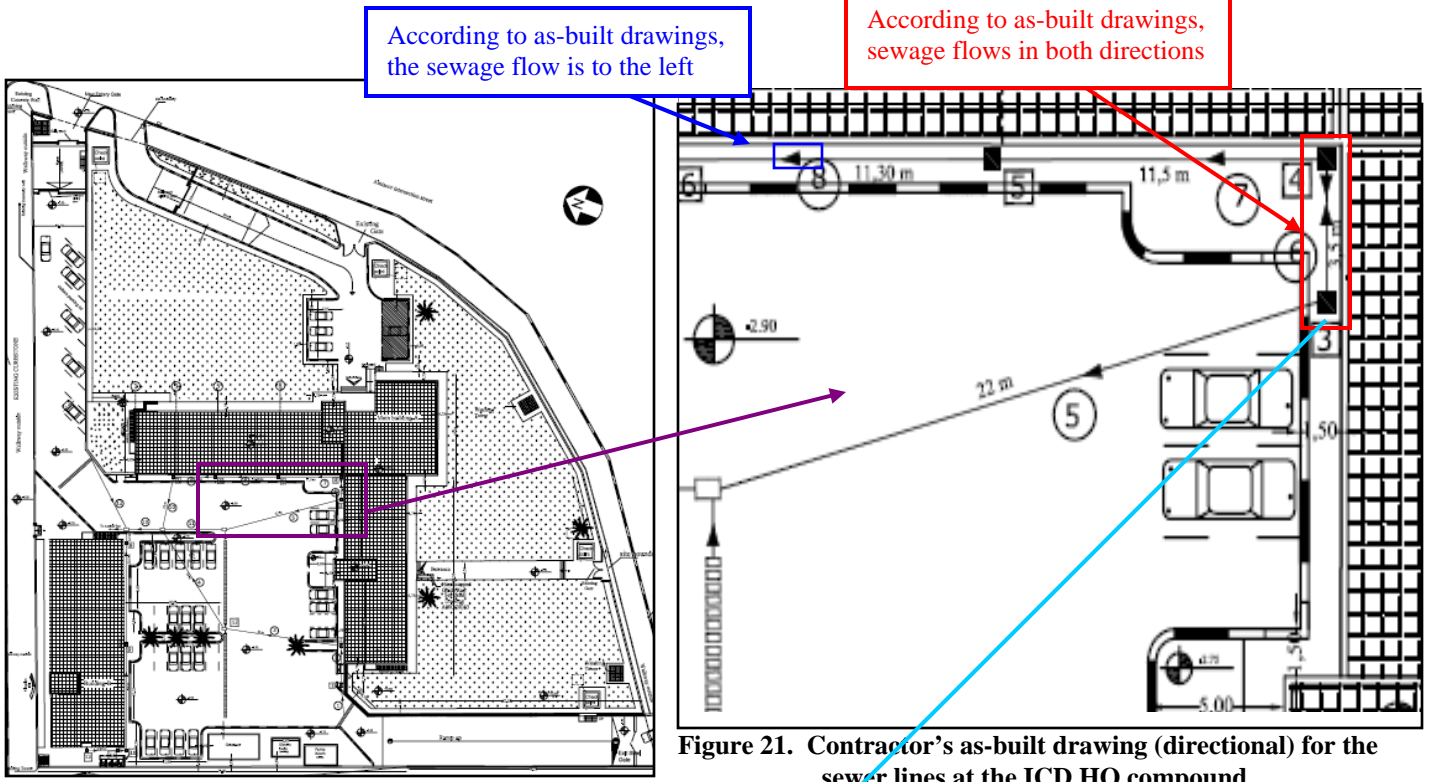

Figure 20. ICD HQ compound

Figure 21. Contractor's as-built drawing (directional) for the sewer lines at the ICD HQ compound

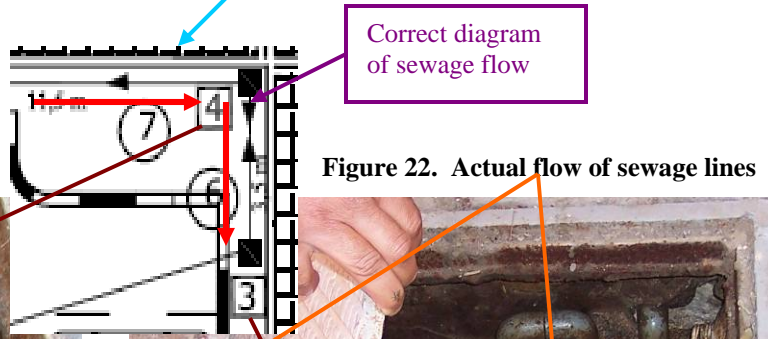
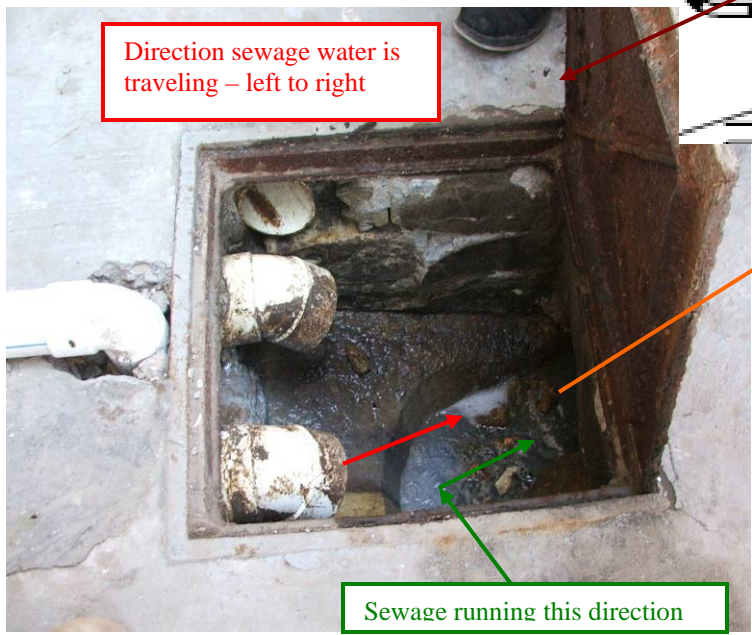
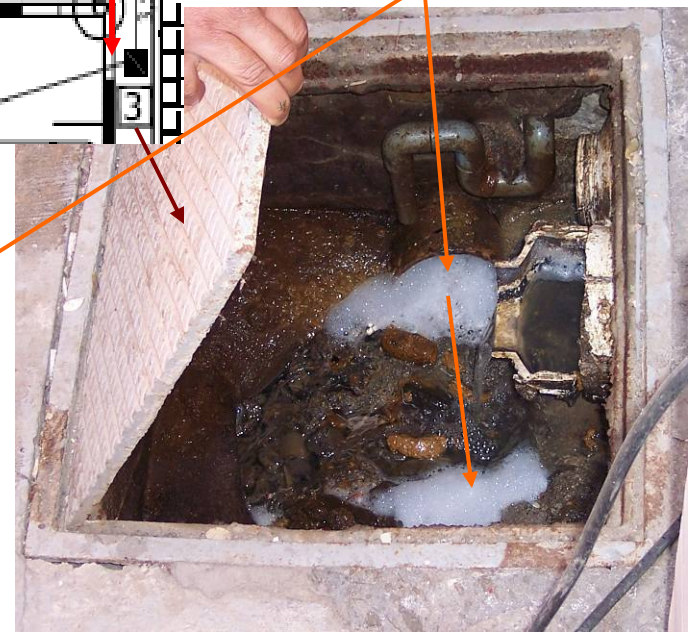

Figure 22. Actual flow of sewage lines



Site Photo 61. Manhole #4 from contractor's as-built drawing



Site Photo 62. Manhole #3 from contractor's as-built drawing

Work in Progress and Work Pending

At the time of our initial site visit, GRD representatives stated the project was complete. However, at this time there appears to be a difference of opinion as to the status of the project. The ICD HQ personnel believe the contractor and subcontractor are still responsible for the punch list of deficiency items; while GRD and Parsons believe the project has been completed.

According to the TO SOW, a final inspection must be done prior to acceptance of the project. The inspection was to concentrate on the items identified at the pre-final inspection “Punch List” and recorded in the pre-final report. The final inspection report must “(1) certify that items of the plan have been implemented and that the construction is complete; (2) include a record of as-built drawings verifying that development standards have been met. At the final inspection, the Contractor will present a completed DD Form 1354, Transfer and Acceptance of Real Property to the CPA or appropriate organization for signature and acceptance.”

Beneficial Occupancy

The transfer of the ICD HQ renovation and construction project to the ICDD should have been simultaneous with the acceptance of the construction from the contractor. According to USACE ER 415-345-38, “...only facilities which have been completed according to contract (task order) requirements, or substantially completed with minor deficiencies which will not interfere with the designed use of the facilities, will be accepted from the contractor and transferred to the customer.”

On 11 March 2005, a Beneficial Occupancy inspection of the ICD HQ project was conducted by representatives from GRC and Parsons. The inspection identified 7 pages of deficiencies and punch list items that “still require correction and/or replacement...” Deficiencies and punch list items such as the following were noted during the inspection:

- “slab poured without vibrating the concrete”
- “the electrical outlets not installed properly”
- “need fire alarm detector” and
- “in the room 235 there is concrete slab poured without taking any samples for test”

According to GRD documentation, the DG of the ICD HQ on 29 April 2005 requested a Beneficial Occupancy inspection of the project in order to use the facilities. However, on 5 May 2005, the facility was “not ready to be occupied – lacked fire alarms/emergency exit lighting.”

Final Inspection/Certificate of Project Completion and Turn-Over

On 1 July 2005, a Parsons senior vice-president/program manager and GRC PE jointly signed the Final Inspection form for the ICD HQ, acknowledging that the “work performed under the subject contract meets the standards set forth in the contract plans, and specifications and that all warranty, as-built drawings, operating manuals, etc. have been turned over to the appropriate PCO representatives.”

During the final inspection, a single page of deficiencies and punch list items was created and noted on the form signed by Parsons and GRC.

On 1 July 2005, Parsons generated its own “Certificate of Project Completion and Turn-Over” form which “Certifies the Project Milestones of Final Acceptance has been

achieved.” This form was signed by representatives from PCO, USACE, the ICD HQ project manager, and Parsons. However, instead of preparing the TO required DD Form 1354, Transfer and Acceptance of Real Property, apparently Parsons attempted to use this form to turn over the ICD HQ project to the USACE, since no ICD HQ personnel were requested to sign it or even asked if the deficiency and punch list items from the 11 March 2005 Beneficial Occupancy inspection were completed. One of the punch list items from the 1 July 2005 final inspection was to “verify the proper operation of sally port doors.” Considering the Sally Port doors provide security for the entire ICD HQ compound, it is questionable how either Parsons or the USACE determined this project was acceptable for turn over.

In addition, on 20 July 2005, the government’s review of the as-built drawings determined they were “incomplete and incorrect and do not reflect our comments made on the previous submission.” The as-built drawings were so questionable that the reviewer suggested the following:

“...the Construction Manager who has been following the work on a daily basis verify the accuracy of these drawings if they truly represent the work as it was done. If they do, then most of the work done is incorrect and does not comply with any code. I am therefore rejecting this submission.”

Further, even though the Final Inspection form dated 1 July 2005 stated that “all warranty, as-built drawings, operating manuals, etc have been turned over to the appropriate PCO representatives,” a USACE document stated that as of 3 July 2005, the contractor still had to “forward O&M manuals and catalog cuts to PCO.” In addition, as of 28 July 2005, the deficiency items from the final inspection were still outstanding.

Considering the numerous examples of violations of the contract and TO required international standards for plumbing and electrical installation identified throughout this report, we question the validity of the PE sign off on the project stating the “work performed under subject contract meets the standards set forth in contract plans...”

Outstanding Deficiency Items

From July 2005 through December 2005, the contractor continued to work on the existing deficiency lists. In addition, in January 2006, according to GRD documentation, an “agreed upon punch list has been developed by all parties.” The contractor spent the next several months correcting the deficiencies. On 15 April 2006, GRD documentation stated that it “received information for our Iraqi QA that the work on the punch list has been completed.” Three days later, GRD confirmed that the “punch list has been completed.”

Notice of Contract Completion

On 1 June 2006, GRC issued a Notice of Completion document stating that the “U.S. Army Corps of Engineers relinquish responsibility of the facility from Parsons Delaware, Inc. to the Ministry of Interior. Final completion of the subject facility was accomplished 11th April 2006.”

The Notice of Completion also stated the “construction has been checked by our Quality Assurance Representative and accepted as completed per the contract between the U.S. Army Corps of Engineers and Parsons Delaware, Inc.”

The Notice of Completion continued with the following:

“...the Government retains all rights under the Warranties clause of the contract on all work associated with punch list items only. The Warranty period shall commence on the date of final completion of warranty items, stated previously. Care and maintenance of subject facility other than warranty service on punch list items is now the responsibility of Ministry of the Interior.”

This Notice of Completion did not mention the specific punch list items to which it was referring. At the time of this document, there had previously been four separate punch lists generated from the following events:

- Beneficial Occupancy inspection (11 March 2005)
- Final Inspection (1 July 2005)
- Punch list GRD stated was “agreed upon by all parties” (January 2006)
- Punch list from 3 May 2006 (noted on the Notice of Completion document)

Considering each punch list contained different items, the Notice of Completion is ambiguous at best as to which punch list items the warranty clause still covered. In addition, this document does not detail the rationale for why the entire project is still not under warranty.

Status of the Deficiencies, Punch List Items, and Warranties

The Notice of Contract Completion letter was signed by representatives from GRC, Parsons, and the ICDD. However, the ICDD representatives noted the following on the document:

“please refer to our civil defence [sic] attached punch list dated 3 May, 2006.”

ICD HQ personnel stated that the ICDD representative only signed the document because he was promised the attached punch list would be honored by GRC and Parsons. The 3 May 2006 ICDD punch list consisted of the following items:

- generator overheating
- replacing the transformer
- fire alarm defective
- replacing 3 malfunctioning computers
- water leakage onto the ground floor Operations Room

However, according to ICD HQ personnel, after signing this document, GRD representatives informed the ICDD representatives that their conditions were not acceptable.

With regard to the Notice of Completion form, in a meeting on 9 April 2007, GRD representatives stated the warranty clause language included on the form was added by the USACE PE and not legally binding.

According to Modification 17 to the basic contract:

“...the SUBCONTRACTOR’s warranties set forth in paragraph A above shall extend for a period of eighteen (18) months after the date of final written acceptance of the Work by Contractor and Owner, or twelve (12) months after the start of regular operation or use of the Work by Owner, whichever occurs first.”

A GRD Memorandum for the Record, dated 27 January 2007, stated that the ICD HQ “facility has had beneficial occupancy since March 2006.” Considering beneficial

occupancy occurred prior to the date of written acceptance of the work by the contractor and owner, the subcontractor's warranties extend until March 2007.

Since the ICDD representative made the GRC and Parsons representatives aware of construction deficiencies, specifically notifying GRC and Parsons through the use of punch lists of continual plumbing leakage problems, prior to the expiration of the warranty, Parsons and its subcontractor are still responsible for corrective actions. Even though GRD representatives viewed the construction deficiencies in January 2007 (well within the warranty period), no effort has been made to have the subcontractor repair or replace the defective work, which has only worsened since our initial site visit.

Project Quality Management

Contractor Quality Control Program

Department of the Army ER 1180-1-6, dated 30 September 1995, provides general policy and guidance for establishing quality management procedures in the execution of construction contracts. According to ER 1180-1-6, "...obtaining quality construction is a combined responsibility of the construction contractor and the government."

The contract for the ICD HQ required the contractor to establish and maintain an effective QC system in compliance with the contract clause title "Inspection of Construction." This required the contractor to maintain an inspection system and perform inspections to ensure that the work performed conformed to contract requirements. The contractor must maintain complete inspection records and make them available to the government. The QC system consists of plans, procedures, and organization necessary to produce end products which comply with the contract requirements.

Parsons developed a QC plan for TO 02, which established procedures and practices for effective determination of conformance to the standards of quality for materials, construction procedures, and final design of the TO project specifications. The plan stressed the careful inspection, testing, oversight, and documentation during the entire construction phase. Parsons QC Representatives (QCR) completed a daily QC report for all activities at the site. In addition, preparatory and initial inspection reports, test results, non-conformance reports, and other requested information is to be included.

GRD provided us with approximately 180 daily QC reports for the ICD HQ project. The daily reports covered the time period of July 2004 through June 2005. The daily QC reports contained information such as the number of workers on site each day, the work accomplished, equipment at the site, materials delivered to the site, inspection and test results, non-conformance items found, and government personnel on site.

We reviewed all the GRD provided daily QC reports and found them inadequate. The QCR monitored field activities and completed daily QC reports; however, the daily QC reports did not always include sufficiently complete daily observations of what occurred at the site, problems encountered at the site that required corrective actions, or solutions achieved to correct the problems at the site. For example, each daily QC report was vague when describing work accomplished ("continue work in the site plan excavations"). Further, not a single daily QC report identified a construction deficiency or an international code violated at the ICD HQ. Considering at least 10 pages of deficiencies and punch list items were identified during the pre and final inspections, the absence of any daily QC deficiencies makes us question the capabilities and

qualifications of the QCR. In addition, the QCR failed to document and, more importantly, correct the subcontractor's violations of the IPC, which we documented throughout this report. The plumbing issues the ICD HQ personnel are facing currently are a direct result of the subcontractor not adhering to the IPC standards; and it was the QCR's responsibility to enforce the international standards.

The daily QC reports did not contain any test and/or inspection results. In each of the 180 daily QC reports, the "Inspection/Testing" section was blank. In the "Test Results" section of this report, we stated that Parsons did not provide the government any test results for any of the work done for this project. Therefore, there is no certainty that any of the plumbing or electrical systems were tested prior to turn over to the ICDD.

Further, aside from the first couple weeks, the daily QC reports did not contain any construction photographs, which are crucial to any successful QC program. A qualified QCR would provide detailed photographs, which reinforce the narrative information within the daily QC reports. In addition, photographs of deficiencies caught and corrected is an effective QCR tool. Further, providing daily site photographs allows those individuals responsible for reviewing the daily QC reports the opportunity to identify additional deficiencies missed by the QCR. Without any photographs from the critical construction stages of the project (i.e. plumbing and electrical installation) no additional deficiencies could be caught.

Finally, no QC deficiency log existed for this project. Deficiency logs are important to document identified deficiencies and the corrective actions taken to correct each deficiency. Without a QC deficiency log, it is unknown what, if any, deficiencies were caught and corrected.

Government Quality Assurance Program

USACE ER 1110-1-12 and the Project and Contracting Office (PCO) Standard Operating Procedure (SOP) CN-100 specified requirements for a government QA program. Specifically, PCO SOP CN-100 provides guidance for the GRD staffs to "...ascertain if the contractor CQC system is functioning and the specified level of construction quality is being attained."

GRD provided us with three months worth of daily QA reports; the daily QA reports covered the time frame from May 2005 to July 2005. We reviewed the daily QA reports and determined they were vague and did not document critical information. For example, the daily QA reports consisted of a single page (in many instances only half a page) that only addressed the following topics and questions:

- Daily report to higher HQ
- What work activities were being performed?
- General remarks
- What contractors were on the jobsite today?

The daily QA reports were vague regarding the work performed ("work on install the interior lights wires for the water pump room") and provide little insight into any problems encountered at the site. For example, in the 23 April 2005 daily QA report, the Quality Assurance Representative (QAR) stated the following:

"The steel sections used in the guard tower frame covered by the rust, also the steel sections did (sic) not welded properly which produce unsymmetrical frame."

The standard practice is to document construction deficiencies and corrective actions taken by the subcontractor through the use of a QA deficiency log. However, no deficiency log was maintained by the QAR. Consequently, it is unknown if the QAR attempted to correct the problem of the subcontractor using previously rusted steel sections for the guard tower.

The QAR did provide site photographs to accompany the daily QA reports. While the site photographs documented some construction deficiencies, the narratives do not identify or address the underlying cause of each deficiency. For example, in a 6 March 2006 daily site photograph, the QAR stated:

“All the bathrooms & the kitchens in the first & the second floor have leaks problems & some have ceramic tiles takeoff.”

The attached site photograph showed the deficiency; however, the only cause identified was “leaks problems” and no corrective action was determined. It appears that the subcontractor simply removed the cracked and raised tiles and replaced them. Without identifying and addressing the cause of the leak, replacing the tile will not ultimately correct the problem.

Further, the QARs failed to identify any instances where the subcontractor did not follow the required international standards. For example, the QAR on 14 March 2006 provided a photograph of interior bathroom plumbing that clearly violates IPC standards (Site Photo 11). The plumbing pipes do not have the required cleanouts and the joints will be cemented in place. The QAR’s narrative below the picture does not mention that the subcontractor’s practices do not follow IPC standards; instead, the narrative stated that the pipes were ready for testing.

The GRC Resident Engineer (RE) did not effectively supervise the QARs. The RE was responsible for reviewing the daily QA reports, and when the QAR provided photographs showing significant water leakage from the bathrooms (Site Photos 63 and 64), the RE should have realized the subcontractor’s plumbing installation techniques were not in compliance with required code. The RE was responsible for identifying this fact and proactively correcting it. Yet there is no indication the RE brought this to the attention of the QAR or subcontractor.

In addition, the GRC RE should have visited the construction site periodically to gauge the performance of the QARs, the QCR, and the subcontractor. Had the GRC RE visited the ICD HQ project site, he would have seen the ground floor sewer PVC pipe ran outside the main building to the manhole (Site Photos 14 and 15). This would have been further proof that not only was the subcontractor violating IPC standards, but also that the QAR was not effectively identifying and including any obvious deficiencies in any previous daily QA reports. However, according to the 180 daily QC reports provided by GRD, no one from the government visited the site from July 2004 through June 2005.



**Site Photo 63. Water damage identified in previous QA reports
(Photo courtesy of USACE)**



**Site Photo 64. Water damage identified in previous QA reports
(Photo courtesy of USACE)**

Indications of significant water leaks

Overall Quality Management

It appears that Parsons did not effectively manage, and the USACE did not provide adequate oversight of the renovation and construction of the ICD HQ project. Parsons was required to manage the renovation and construction of the project and provide QC; while the USACE was responsible for providing QA oversight of the renovation and construction for the U.S. government. Neither the QC nor the QA daily reports identified the fact that the subcontractor did not follow the standards required by the contract and the TO. For example, the QAR caption to the photograph (Site Photo 75) from the 6 March 2006 daily QA report stated the following:

“Leaks from the first floor bathrooms through the ceiling, the contractor want to repair only this part in the ground floor ceiling.”

When we visited the same location one year later, we identified the same damage in the exact same place (Site Photos 65 and 66). The daily QA report only documented the location of the leak, not the cause of it. In addition, the QAR and RE allowed the contractor to dictate the area of cleanup. The QAR and RE should have required the contractor to dig up the entire area to isolate and determine the cause of the leak and make the required corrective actions.

Consequently, ineffective on-site management and lack of adequate government oversight at the ICD HQ project has resulted in continuing construction quality issues.

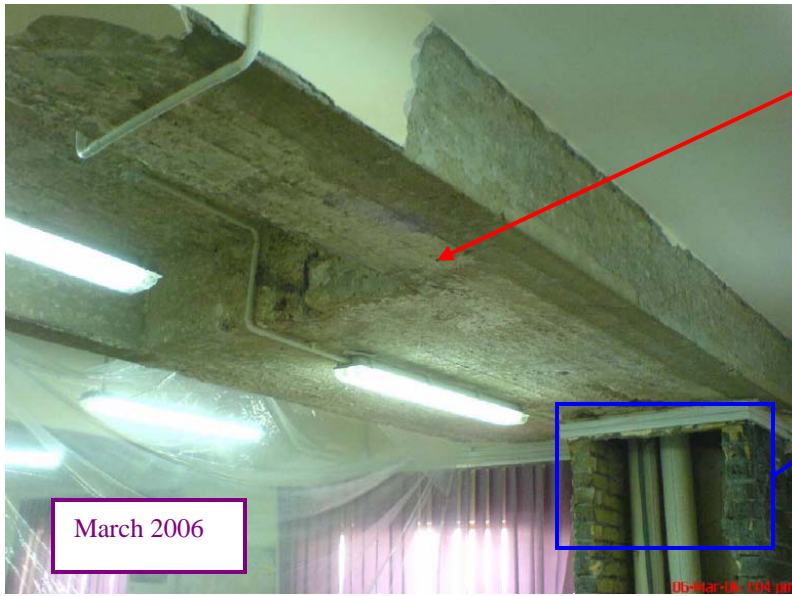

Site Photo 65. Location of previous water damage
(Photo courtesy of USACE)



Site Photo 66. Water damage one year later

Project Sustainability

The contract's Warranty of Construction clause stated that the contractor warrants that work performed under this contract conforms to the contract requirements and is free of any defect in equipment, material, or design furnished, or workmanship performed by the contractor or any subcontractor or supplier at any tier. This warranty shall continue for a period of 1 year from the date of final acceptance of the work. If the government takes possession of any part of the work before final acceptance, this warranty shall continue for a period of 1 year from the date the government takes possession.

The contractor shall remedy at the contractor's expense any failure to conform, or any defect. In addition, the contractor shall remedy at the contractor's expense any damage to government owned or controlled real or personal property, when the damage is the result of the following:

- The contractor's failure to conform to contract requirements
- Any defect of equipment, material, workmanship, or design furnished

The contractor shall restore any work damaged in fulfilling the terms and conditions of this clause. The contractor's warranty with respect to work repaired or replaced will run for 1 year from the date of repair or replacement.

If the contractor fails to remedy any failure, defect, or damage within a reasonable time after receipt of notice, the government shall have the right to replace, repair, or otherwise remedy the failure, defect, or damage at the contractor's expense.

Modification 17, dated 12 January 2006, to the basic contract stated the following with regards to warranties:

“the SUBCONTRACTOR’s warranties set forth in paragraph A above shall extend for a period of eighteen (18) months after the date of final written acceptance of the Work by Contractor and Owner, or twelve (12) months after the start of regular operation or use of the Work by Owner, whichever occurs first.”

In addition, Modification 17 also stated the following with regards to warranties:

“All labor, equipment, and materials furnished by SUBCONTRACTOR pursuant to paragraph A above to correct defects shall be warranted by SUBCONTRACTOR in accordance with the warranties set forth in paragraph A above for a period of twelve (12) months from the date of acceptance by Contractor of such correction.”

The TO specifications required that the contractor provide warranties for all equipment and operation for 12 months after issuance of the Contractor’s Release. In addition, the contractor must provide the catalog cuts of major equipment items, materials list, materials manufacturers/suppliers, and manuals in Arabic and English.

Meeting with GRD regarding warranties

During our meeting on 9 April 2007, GRD representatives stated that contract Modification 17 was not applicable for this project for three reasons. First, Modification 17 was issued after the TO had been definitized and was almost complete. Second, after a legal review of Modification 17, GRD determined the modification was unenforceable because the basic contract agreement was between the Government and Parsons, not the subcontractor; therefore, Parsons’ warranties with the subcontractor could not be directly passed to the Government. Further, GRD representatives stated that the TO warranties supersede the basic contract’s warranties. The basic contract warranties provide provisions against poor quality workmanship by the contractor; while the TO warranties provided provisions for equipment and materials only. According to GRD representatives, a cost plus TO is a “level of effort” agreement and the only provisions against poor quality workmanship are latent defects and fraud. GRD representatives believe that the contractor’s performance of this project does not constitute either fraud or latent defects; therefore, they contend there is no remedy for the poor quality workmanship identified throughout this report under the warranties clause of the TO.

Finally, GRD representatives stated that in order to enforce the warranties, the Government would have to pay Parsons for its overhead costs under an Administrative Task Order. GRD representatives said it would be more cost effective to issue another contract for the warranty repairs than to pay Parsons its overhead costs to do the required warranty repairs.

Conclusions

Based upon the results of our site visit, we reached the following conclusions for our assessment objectives. Appendix A provides details pertaining to Scope and Methodology.

1. Not all project components were adequately designed prior to renovation and construction at the Iraqi Civil Defense Headquarters. The United States Army Corps of Engineers could not locate the required 30% and 60% design submittal packages; instead providing only the 100% final design drawing submittal package. Without the required design submittal packages, we could not

determine if the requisite information was included. In addition, the government representative who apparently had access to the design submittal packages, rejected the 30% and 90% design drawings because they were incomplete and lacked important information necessary for construction.

We reviewed the design drawing submittal marked as the 100% final drawing package and found it inadequate due to the absence of quality, detailed design construction drawings. The contractor's drawings lacked significant and basic design details, such as the rough-in and finish-out for the installation of plumbing fixtures (a riser diagram for both fresh water and soil piping) and the need for an adequate number of cleanouts and traps. Without detailed design drawings, the subcontractor does not have adequate guidance to properly install the water lines and plumbing fixtures. In addition, the submitted design drawings did not include electrical design for each line identifying the amount of load on one particular breaker and the number of outlets and/or lighting fixtures on each line. The absence of this critical information significantly increases the potential for a short circuit, which could lead to an electrical fire.

Further, with regards to the Sally Port gates, we believe the mechanism to move the gate from one end to the other was not adequately designed and configured. A properly designed steel rolling gate would have included load calculations, such as the weight of the gates while in motion, to determine the correct size motor to operate the gates. The motor provided does not have adequate horse power to move the gate; consequently, the motor cannot produce the required torque to operate the gates. In addition, another poorly designed aspect of this gate system is that it does not provide any locking mechanism once it reaches the destination point (the other wall). The intent of this gate was to provide explosive-proof security for the ICD HQ compound, which means prohibiting a suspected vehicle from entering the compound. However, there are no mechanisms to keep the door in the intended (locked) position.

2. Instances were noted in which work performed did not meet the standards of the contract and task order. The contract and task order identified the minimum standards for construction, such as the International Plumbing Code and International Electro-Technical Committee. We identified construction deficiencies, such as poor plumbing, electrical, and sally port gate installation. In addition, the plumbing work did not comply with the prescribed international standards.
3. The contractor's quality control plan was sufficiently detailed, including the use of daily quality control reports to document construction deficiencies; yet the contractor's quality control program implementation failed to identify significant construction deficiencies, such as poor plumbing installation practices. Specifically, the daily quality control reports did not identify any construction deficiencies or international standard violations. In addition, the daily quality control reports did not contain any test and/or inspection results. Further, no quality control deficiency log existed for this project.

The government quality assurance program was not fully operational. The daily quality assurance reports were vague and did not document critical information, such as insight into any problems encountered at the site. The Quality Assurance Representative's site photographs showed deficiencies; however, the root cause of the problem was not addressed and corrective actions, if taken, were not always documented. In addition, the QAR did not identify any instances in which the

subcontractor did not follow the required international standards. Obvious violations of the International Plumbing Code, such as exposed sewer pipes leading from the ground floor bathroom to the outside manhole, were not identified and corrected.

4. Sustainability was addressed in the task order requirements, but not adequately administered. Documented instances of non-compliance with contract and task order required international standards for plumbing and electrical installation, give concern that the existing problems will worsen over time and render at least part of the ICD HQ buildings unusable. For example, the continuing water leakage onto the ground floor Operations Room has already limited the use of a portion of the Operations Room.; while the electrical fires around the fluorescent light fixtures present continual safety problems for the entire headquarters facility.

Further, the as-built drawings submitted by the contractor, in many cases, do not reflect the work that was actually done. Accurate information in the as-built drawings is needed for proper operations and maintenance, effective warranty enforcement, and future repair and renovation work.

Finally, according to the USACE, the basic contract warranties provide provisions against poor quality workmanship by the contractor; while the task order warranties provided provisions for equipment and materials only. In addition, USACE representatives described the cost plus task order as a “level of effort” agreement and the only provisions against poor quality workmanship are latent defects and fraud. They do not believe the contractor’s performance for this project constituted fraud or latent defects; therefore, they contend there is no remedy for the poor quality workmanship identified throughout this report under the warranties clause of this task order. Also, the USACE stated that in order to enforce the warranties, the government would have to pay the contractor for its overhead costs under an Administrative Task Order. As a result, the USACE indicated that it had determined it would be more cost effective to issue local contracts for the warranty repairs.

5. The ICD HQ is occupied and used by the Iraqi Civil Defense Directorate for its headquarters’ functions. However, the renovation and construction results were not fully consistent with the original contract and task order objectives. At the time of our inspections, the renovated main office buildings were experiencing plumbing failures and electrical fires, which will leave the Iraqis with continual maintenance issues.

The USACE representatives pointed out that the water leaks may be due to installation of showers by the ICD HQ after completion of contract work. Though the showers installed by ICD HQ were a minimum of 27 feet from the site of the water leak, it is possible that the showers were responsible for the leak or some portion of the leak. Additionally, upon being alerted to the electrical fires the USACE initiated immediate action to determine the cause of the fires.

Recommendations

We recommend that the Commanding General, Gulf Region Division:

1. Determine the cause of the plumbing leaks and take action to repair any portion due to deficient work on the part of the U.S. Government contractor.

2. Complete the investigation initiated during our assessment to determine the cause of the electrical fires. If the light fixtures are the cause, require the manufacturer replace all lighting fixtures throughout the facility. If the light fixtures are not the cause of the electrical fires, seek additional funding to perform an engineering analysis to determine the specific cause of the electrical fires.

Management Comments

The Gulf Region Division concurred with comments to the recommendations contained in the report. Specifically, the Gulf Region Division stated it will complete an assessment of the identified plumbing and electrical deficiencies within 30 days and pursue corrective actions for any deficiencies related to the original contractor's work.

Evaluation of Management Comments

Management comments addressed the issues raised in the reports. The Gulf Region Division's planned actions are responsive and should identify the cause(s) of the plumbing and electrical deficiencies. The appropriate corrective actions will be taken by the Gulf Region Division once the origins of the plumbing and electrical deficiencies are identified.

Appendix A. Scope and Methodology

We performed this project assessment from January through April 2007 in accordance with the Quality Standards for Inspections issued by the President's Council on Integrity and Efficiency. The assessment team included two engineers/inspectors and three auditors/inspectors.

In performing this Project Assessment we:

- Reviewed contract documentation to include the following: Contract, Contract Modifications, Task Order 2, Task Order 2 Modifications, Contract documentation, and Scope of Work;
- Reviewed the design package (drawings and specifications), quality control plan, contractor's quality control reports, United States Army Corps of Engineers (USACE) quality assurance reports, construction progress photos, punch lists, and turnover letters;
- Interviewed the USACE Gulf Region Central personnel and USACE Gulf Region Division personnel; and
- Conducted on-site assessments and documented results at the Iraqi Civil Defense Headquarters reconstruction and renovation project in Baghdad, Iraq.

Appendix B. Contract, Task Order, and Modifications

The Iraqi Civil Defense Headquarters (ICD HQ) project was completed under Contract W914NS-04-D-0009, dated 26 March 2004, as a cost plus award fee for the base period. The contract was between the Coalition Provisional Authority and Parsons Delaware, Inc., Pasadena, California (Parsons). Contract W914NS-04-D-0009 minimum, including option periods, is \$500,000 and the maximum total of all orders under the contract is \$900,000,000. There were 19 modifications to the initial contract:

- Modification # P00001, issued 3 August 2004, included the language for processing invoices.
- Modification # P00002, issued 3 August 2004, included the language for processing invoices.
- Modification # P00003, issued 13 August 2004, corrected the modification number on the last modification issued, dated 3 August 2004, from P00001 to P00002.
- Modification # P00004, issued 18 October 2004, transferred administrative responsibility for task orders issued for this contract to the United States Army Corps of Engineers (USACE) Gulf Region Division (GRD). The contracting officer reserves the right to modify this delegation for specific TOs.
- Modification # P00005, issued 20 October 2004, incorporated the attached letter of instruction regarding procedures for hostage reporting into the contract.
- Modification # P00006, issued 8 November 2004, incorporated the revised Award Fee Plan and to adjust the Award Fee Period. The initial award fee period was extended to 26 December 2004. Beginning the 26 March 2005, the six month award fee periods would resume.
- Modification # P00007, issued 3 December 2004, incorporated the Subcontracts (FAR 52.244-2), Competition in Subcontracting (FAR 52.244-5), and Inspection of Services – Cost Reimbursement (FAR 52.246-5) clauses into the contract. In addition, the warranty language in the TO issued under the contract is restricted to commercial warranties provided by the original equipment manufacturer. As a result of this modification, there is neither an increase nor a decrease in the total amount of this contract.
- Modification # P00008 was not located in the contract file and the following offices (Project and Contracting Office (PCO), the USACE Area Engineer, Resident Engineer (RE), Quality Assurance Representative (QAR), and Parsons Task Manager) were contacted regarding Modification #P00008, but were unable to locate the modification. Modification P00015 stated that Modifications P00003, P00005, P00007, and P00008 do not exist.
- Modification # P00009, issued 4 August 2005, incorporated Defense Federal Acquisition Regulation Supplemental 245.505-14 Contract Clause Defense Federal Acquisition Regulation Supplemental 252-245.7001 Reports of Government Property in the contract.
- Modification # P00010, issued 8 August 2005, transferred administrative responsibility for the TOs issued for this contract to the USACE GRD district offices directly. The Memorandum of Understanding is effective 21 July 2005.
- Modification # P00011, issued 25 August 2005, further amended the Award Fee Plan of the base contract. The changes are made unilaterally and are effective for the award fee period(s) starting after 26 September 2005.
- Modification # P00012, issued 26 October 2005, included the following sentence to the Statement of Work 00020 2.6: “Contractor may obtain fuel from Government sources, when available, in support of this contract.”

- Modification # P00013, issued 29 October 2005, rescinded Modification P00012, effective date 6 October 2005. There is no change to Modification P00012, effective date 26 October 2005.
- Modification # P00014, issued 27 November 2005, is to change the word “fifth” in Section 00020 Statements of Work, Paragraph 2.3.5 to “twentieth”.
- Modification # P00015, issued 27 December 2005, changed modification P00001 to read P00002, effective date as 3 August 2004. Modification P00001 had an effective date of 6 April 2004. Modification P00015 stated that Modifications P00003, P00005, P00007, and P00008 do not exist.
- Modification # P00016, issued 28 December 2005, incorporated the requirements for subcontract and capacity development reporting into the Subcontracting Excellence Program Database in accordance with the Subcontracting Excellence Program Database Standard Operating Procedure PR-127 previously furnished.
- Modification # P00017, issued 12 January 2006, included a warranties section for the contract. Except as described above, all terms and conditions remain unchanged and in full force and effect.
- Modification # P00018, issued 5 February 2006, is the transfer GP#743906-1120 (2000 liter fuel tank) from contract number W914NS-04-D-0009 (Parsons Security & Justice) to contract number W914NS-D-0006 (Parsons BHE). All other terms and conditions remain unchanged.
- Modification # P00019, issued 8 February 2006, is to exercise the option for the period of 26 March 2006 through 25 March 2007 in accordance with the option to extend the term of the contract. All other terms and conditions remain unchanged.

There was one TO associated with work at the ICD HQ – TO 02. TO 02, dated 24 April 2004, was not to exceed \$742,450.00. This TO included a notice to proceed and requested a Rough Order of Magnitude for specific site work at the Civil Defense Headquarters. TO 02 currently contains 8 modifications.

- Modification 01, dated 12 July 2004, definitized the TO to renovate the ICD HQ in the amount of \$1,354,583.00.
- Modification 02, dated 1 August 2004, assigned contract administration of the TO to the USACE.
- Modification 03, dated 25 January 2005, authorized Parsons to proceed on TO 02 and increased the not to exceed amount from \$1,354,583.00 to \$2,567,200.00.
- Modification 04, dated 12 February 2005, definitized SOW in Modification 3 and increases contract costs from \$1,200,976.00 to a total of \$2,567,201.00. The base fee was increased from \$36,024.00 to \$67,716.00, an increase of \$31,692.00. The award fee was increased from \$117,583.00 to \$241,984.00, an increase of \$124,401.00. Added a clause to the contract that DCAA will audit the contractor’s final certified cost proposal.
- Modification 05, dated 28 February 2005, allows the contractor to invoice for award fee in the amount of \$74,959.00. The TO is decreased from \$2,567,201.00 to \$2,553,973.00.
- Modification 06, dated 22 May 2005, authorized invoicing for the award fee for the period 26 September 2004 through 26 March 2005. Reduced by \$29,101.00 the award fee pool for unearned fees. Authorized the contractor to invoice \$64,200.00 for award fee.
- Modification 07, dated 29 May 2006, authorized the contractor to invoice \$0.00 and descope the unearned award amount of \$60,496.00 for the period of 27 September 2005 through 26 March 2006.
- Modification 08, dated 2 June 2005, increased funds in response to Parson’s request for equitable adjustment dated 12 December 2005. The TO increased by \$535,688.00 from \$2,464,376.00 to \$3,000,064.00.

Appendix C. Acronyms

| | |
|---------|---|
| ACI | American Concrete Institute |
| ASTM | American Society of Testing and Materials |
| DG | Director General |
| ER | Engineering Regulation |
| GRC | Gulf Region Central |
| GRD | Gulf Region Division |
| ICDD | Iraqi Civil Defense Directorate |
| ICD HQ | Iraqi Civil Defense Headquarters |
| IBC | International Building Code |
| IEBC | International Existing Building Code |
| IEC | International Electro-Technical Committee |
| IFC | International Fire Code |
| IPC | International Plumbing Code |
| Parsons | Parsons Delaware, Inc. |
| PE | Project Engineer |
| PCO | Project and Contracting Office |
| PVC | Polyvinyl Chloride |
| QA | Quality Assurance |
| QAR | Quality Assurance Representative |
| QC | Quality Control |
| RE | Resident Engineer |
| SOP | Standard Operating Procedure |
| SOW | Scope of Work |
| SPMO | Sector Project Management Office |
| TO | Task Order |
| USACE | United States Army Corps of Engineers |

Appendix D. Report Distribution

Department of State

Secretary of State

Senior Advisor to the Secretary and Coordinator for Iraq

Director of U.S. Foreign Assistance/Administrator, U.S. Agency for
International Development

Director, Office of Iraq Reconstruction

Assistant Secretary for Resource Management/Chief Financial Officer,
Bureau of Resource Management

U.S. Ambassador to Iraq

Director, Iraq Reconstruction Management Office

Mission Director-Iraq, U.S. Agency for International Development

Inspector General, Department of State

Department of Defense

Secretary of Defense

Deputy Secretary of Defense

Under Secretary of Defense (Comptroller)/Chief Financial Officer

Deputy Chief Financial Officer

Deputy Comptroller (Program/Budget)

Deputy Assistant Secretary of Defense-Middle East, Office of Policy/International
Security Affairs

Inspector General, Department of Defense

Director, Defense Contract Audit Agency

Director, Defense Finance and Accounting Service

Director, Defense Contract Management Agency

Department of the Army

Assistant Secretary of the Army for Acquisition, Logistics, and Technology

Principal Deputy to the Assistant Secretary of the Army for Acquisition,
Logistics, and Technology

Deputy Assistant Secretary of the Army (Policy and Procurement)

Director, Project and Contracting Office

Commanding General, Joint Contracting Command-Iraq/Afghanistan

Assistant Secretary of the Army for Financial Management and Comptroller

Chief of Engineers and Commander, U.S. Army Corps of Engineers

Commanding General, Gulf Region Division

Chief Financial Officer, U.S. Army Corps of Engineers

Auditor General of the Army

U.S. Central Command

Commanding General, Multi-National Force-Iraq

Commanding General, Multi-National Corps-Iraq

Commanding General, Multi-National Security Transition Command-Iraq

Commander, Joint Area Support Group-Central

Other Federal Government Organizations

Director, Office of Management and Budget
Comptroller General of the United States
Inspector General, Department of the Treasury
Inspector General, Department of Commerce
Inspector General, Department of Health and Human Services
Inspector General, U.S. Agency for International Development
President, Overseas Private Investment Corporation
President, U.S. Institute for Peace

Congressional Committees and Subcommittees, Chairman and Ranking Minority Member

U.S. Senate

Senate Committee on Appropriations
 Subcommittee on Defense
 Subcommittee on State, Foreign Operations and Related Programs
Senate Committee on Armed Services
Senate Committee on Foreign Relations
 Subcommittee on International Operations and Organizations, Democracy and Human Rights
 Subcommittee on International Development and Foreign Assistance, Economic Affairs and International Environmental Protection
 Subcommittee on Near East and South and Central Asian Affairs
Senate Committee on Homeland Security and Governmental Affairs
 Subcommittee on Federal Financial Management, Government Information, Federal Services and International Security
 Permanent Subcommittee on Investigations
 Subcommittee on Oversight of Government Management, the Federal Workforce, and the District of Columbia

U.S. House of Representatives

House Committee on Appropriations
 Subcommittee on Defense
 Subcommittee on State, Foreign Operations, and Related Programs
House Committee on Armed Services
House Committee on Oversight and Government Reform
 Subcommittee on Government Management, Organization, and Procurement
 Subcommittee on National Security and Foreign Affairs
House Committee on Foreign Affairs
 Subcommittee on Middle East and South Asia
 Subcommittee on International Organizations, Human Rights, and Oversight

Appendix E. Management Comments



REPLY TO
ATTENTION OF

DEPARTMENT OF THE ARMY
U.S. ARMY CORPS OF ENGINEERS
GULF REGION DIVISION
BAGHDAD, IRAQ
APO AE 09348

CEGRD-CG

20 April 2007

MEMORANDUM FOR Special Inspector General for Iraq Reconstruction, US Embassy Annex,
M-202, Old Presidential Palace, APO AE 09316

SUBJECT: Revised Draft SIGIR Project Assessment Report – Iraqi Civil Defense Headquarters,
Baghdad, Iraq (SIGIR-PA-06-090)

1. This memorandum provides the U.S. Army Corps of Engineers, Gulf Region Division (GRD) response to the subject project assessment report.
2. In the report, SIGIR concludes that the construction was not consistent with the contract objectives and singles out plumbing and electrical issues, in particular. It is important to recognize that the Iraqi Civil Defense (ICD) has occupied the facilities for over 24 months. Despite the problems identified in the report, the facility is fully functional and in daily use by several hundred employees. Since occupying the facility, the ICD occupants have made numerous modifications, such as electrical rewiring and the construction of additional showers. We believe these later modifications have contributed to or caused any problems at the facility.
3. GRD is the U.S. Government's lead construction agency in Iraq and is committed to producing safe, reliable construction projects that meet the requirements specified in the contract. GRD will complete an assessment of the identified plumbing and electrical deficiencies within 30 days of the publication of the final SIGIR report. If the deficiencies are related to the original work, GRD will pursue corrective actions.
4. GRD concurs with comments to SIGIR's recommendations. Enclosure 1 provides GRD responses to the recommendations and Enclosure 2 provides additional ICD site photographs.
5. If you have any questions, please contact Mr. Milton Naumann at (540) 665-5021 or his email Milton.L.Naumann@tac01.usace.army.mil

- 2 Encls
1. GRD Responses
2. ICD Site Photos

for

MICHAEL J. WALSH
Brigadier General, USA
Commanding

COMMAND REPLY

SIGIR Revised Draft Assessment Report – Iraqi Civil Defense Headquarters, Baghdad, Iraq (SIGIR-PA-06-090)

1. **Introduction.** The U.S. Army Corps of Engineers (USACE), Gulf Region Division (GRD) is the U.S. Government's lead construction agency in Iraq and is committed to ensuring all its construction projects are safe, reliable and meet the specified requirements of our clients.

The draft SIGIR Report on the Iraqi Civil Defense Headquarters identifies electrical and plumbing deficiencies. Iraqi Civil Defense personnel have occupied these facilities for over 24 months since GRD transferred them to the Government of Iraq. Over this 24 month period numerous facility modifications have emerged such as the addition of showers and rewiring of electrical fixtures. Since the building occupants employed self-help construction it can be difficult to ascertain if deficiencies stem from the original construction or if they are compounded by self-help modifications.

USACE Gulf Region Division will conduct an assessment of the identified plumbing and electrical discrepancies. The assessment will be completed within 30 days of the publication of the final SIGIR report and focus on ensuring the original renovation project produced a complete, reliable and safe Iraqi Civil Defense Headquarters.

2. **SIGIR Recommendations and Gulf Region Division Comments.** SIGIR recommended that the Commanding General, USACE Gulf Region Division:

a. Recommendation 1. Determine the cause of the plumbing leaks and take action to repair any portion due to deficient work on the part of the U.S. Government contractor.

Command Reply. Concur with comment. As previously mentioned, the Iraqi Civil Defense personnel have occupied these facilities for over 24 months. Over this period numerous facility modifications are evident. From our site inspection on 7 April 2007, it is unclear if plumbing leaks are deficient work on the part of the U.S. Government contractor or if they were created by the building occupants' self-help projects.

It is evident that the occupants performed modifications to the U.S. Government contractor's work. Some of these changes include adding showers in areas not designed for a wet application. These self-help showers appear to be the underlying root cause of the leaks associated with water damages to the ground floor conference room. The USACE Gulf Region Division will conduct an assessment of the identified discrepancies to ensure the original renovation project produced a complete, reliable and safe Iraqi Civil Defense Headquarters. If plumbing deficiencies related to the original work are confirmed, we will pursue corrective action.

Enclosure 1

b. Recommendation 2. *Complete the investigation initiated during our assessment to determine the cause of the electrical fires. If the light fixtures are the cause, require the manufacturer replace all lighting fixtures throughout the facility. If the light fixtures are not the cause of the electrical fires, seek additional funding to perform an engineering analysis to determine the specific causes of the electrical fires.*

Command Reply. Concur with comment. From our site inspection on 30 March 2007, we confirmed that some of the original light fixtures were replaced, but were unable to confirm the cause of the problem. The USACE Gulf Region Division will conduct an assessment of the identified discrepancies to ensure the original renovation project produced a complete, reliable and safe Iraqi Civil Defense Headquarters. If electrical deficiencies related to the original work are confirmed, we will pursue corrective action.



Iraq Civil Defense Headquarters open and operating.

Appendix F. Project Assessment Team Members

The Office of the Assistant Inspector General for Inspections, Office of the Special Inspector General for Iraq Reconstruction, prepared this report. The principal staff members who contributed to the report were:

Angelina Johnston

Kevin O'Connor

Yogin Rawal, P.E.