



**NAVAL
POSTGRADUATE
SCHOOL**

MONTEREY, CALIFORNIA

THESIS

**TRANSIENT EFFECTS OF POLYMER-ORGANIC LIGHT
EMITTING DIODES AND THEIR IMPACT ON INDIVIDUAL
IDENTIFICATION FRIEND/FOE (IFF)**

by

James M. Elmore

December 2008

Thesis Advisor:
Second Reader:

Nancy Haegel
Pete Crooker

Approved for public release; distribution is unlimited

THIS PAGE INTENTIONALLY LEFT BLANK

| REPORT DOCUMENTATION PAGE | | | Form Approved OMB No. 0704-0188 | |
|---|--|---|---|--|
| Public reporting burden for this collection of information is estimated to average 1 hour per response, including the time for reviewing instruction, searching existing data sources, gathering and maintaining the data needed, and completing and reviewing the collection of information. Send comments regarding this burden estimate or any other aspect of this collection of information, including suggestions for reducing this burden, to Washington headquarters Services, Directorate for Information Operations and Reports, 1215 Jefferson Davis Highway, Suite 1204, Arlington, VA 22202-4302, and to the Office of Management and Budget, Paperwork Reduction Project (0704-0188) Washington DC 20503. | | | | |
| 1. AGENCY USE ONLY (Leave blank) | | 2. REPORT DATE December 2008 | 3. REPORT TYPE AND DATES COVERED Master's Thesis | |
| 4. TITLE AND SUBTITLE Transient Effects of Polymer-Organic Light Emitting Diodes and their Impact on Individual Identification Friend/Foe (IIFP) | | | 5. FUNDING NUMBERS | |
| 6. AUTHOR(S) LT James Monroe Elmore | | | | |
| 7. PERFORMING ORGANIZATION NAME(S) AND ADDRESS(ES) Naval Postgraduate School Monterey, CA 93943-5000 | | | 8. PERFORMING ORGANIZATION REPORT NUMBER | |
| 9. SPONSORING /MONITORING AGENCY NAME(S) AND ADDRESS(ES) N/A | | | 10. SPONSORING/MONITORING AGENCY REPORT NUMBER | |
| 11. SUPPLEMENTARY NOTES The views expressed in this thesis are those of the author and do not reflect the official policy or position of the Department of Defense or the U.S. Government. | | | | |
| 12a. DISTRIBUTION / AVAILABILITY STATEMENT Approved for public release; distribution is unlimited. | | | 12b. DISTRIBUTION CODE A | |
| 13. ABSTRACT (maximum 200 words) The Individual Identification Friend/Foe (IIFP) patch is a unique system designed to prevent shooter-on-shooter fratricide in a battlefield environment. Using a Polymer-Organic Light Emitting Diode (p-OLED) as the emitter for the IIFP system provides many unique opportunities and challenges in system design. Both high overall brightness in the Infrared (700-900 nm) region and fast turn-on time (e.g., the time it takes from application of bias voltage to full intensity of the emitter) are important for the IIFP system to be successful. In this thesis, six p-OLED candidates are tested for potential use in the IIFP device. The best candidate was determined to be a mixture of two different ink formulations (4:1; Yellow:Red) combined with an updated cathode design. This provided a 410% increase in brightness and faster turn-on compared to the original Covion Yellow emitter in the Infrared. This thesis also includes initial research on material properties of the p-OLED that determine the key factors that went into material selection. P-OLEDs differ from inorganic semiconductors in that the p-n junction is created after a bias voltage is applied and the width of the p-i-n regions varies with the bias voltage applied to the material. Two distinct transient effects during turn-on are determined, and the turn-on intensity as a function of time is able to be modeled as an exponential rise-to-maximum function with two exponential time constants, one on the order of 1 s and the other on the order of 10 s. | | | | |
| 14. SUBJECT TERMS LEP, p-OLED, Conjugated Polymer Organic Light Emitting Diode, IIFP, IIFP, transient behavior | | | 15. NUMBER OF PAGES 65 | |
| | | | 16. PRICE CODE | |
| 17. SECURITY CLASSIFICATION OF REPORT Unclassified | 18. SECURITY CLASSIFICATION OF THIS PAGE Unclassified | 19. SECURITY CLASSIFICATION OF ABSTRACT Unclassified | 20. LIMITATION OF ABSTRACT UU | |

THIS PAGE INTENTIONALLY LEFT BLANK

Approved for public release; distribution is unlimited

**TRANSIENT EFFECTS OF POLYMER-ORGANIC LIGHT EMITTING DIODES
AND THEIR IMPACT ON INDIVIDUAL IDENTIFICATION FRIEND/FOE
(IIF)**

James M. Elmore
Lieutenant, United States Navy
B.S., United States Naval Academy, 2002

Submitted in partial fulfillment of the
requirements for the degree of

MASTER OF SCIENCE IN PHYSICS

from the

**NAVAL POSTGRADUATE SCHOOL
December 2008**

Author: James M. Elmore

Approved by: Nancy Haegel
Thesis Advisor

Pete Crooker
Second Reader

James Luscombe
Chairman, Department of Physics

THIS PAGE INTENTIONALLY LEFT BLANK

ABSTRACT

The Individual Identification Friend/Foe (IIFF) patch is a unique system designed to prevent shooter-on-shooter fratricide in a battlefield environment. Using a Polymer-Organic Light Emitting Diode (p-OLED) as the emitter for the IIFF system provides many unique opportunities and challenges in system design. Both high overall brightness in the Infrared (700-900 nm) region and fast turn-on time (e.g., the time it takes from application of bias voltage to full intensity of the emitter) are important for the IIFF system to be successful.

In this thesis six p-OLED candidates are tested for potential use in the IIFF device. The best candidate was determined to be a mixture of two different ink formulations (4:1; Yellow:Red) combined with an updated cathode design. This provided a 410% increase in brightness and faster turn-on compared to the original Covion Yellow emitter in the Infrared.

This thesis also includes initial research on material properties of the p-OLED that determine the key factors that went into material selection. P-OLEDs differ from inorganic semiconductors in that the p-n junction is created after a bias voltage is applied and the width of the p-i-n regions varies with the bias voltage applied to the material. Two distinct transient effects during turn-on are determined, and the turn-on intensity as a function of time is able to be modeled as an exponential rise-to-maximum function with two exponential time constants, one on the order of 1 s and the other on the order of 10 s.

THIS PAGE INTENTIONALLY LEFT BLANK

TABLE OF CONTENTS

| | | |
|-------------|---|-----------|
| I. | INTRODUCTION..... | 1 |
| A. | WHAT IS IFF?..... | 1 |
| B. | CURRENT IFF DEVICES IN USE | 1 |
| C. | NEED FOR TRIGGERED IFF..... | 4 |
| D. | THESIS OVERVIEW | 6 |
| II. | IFF BACKGROUND, CURRENT DEVICES AND THE NEED FOR NEW MATERIALS | 7 |
| A. | WHAT IS A P-OLED? | 7 |
| B. | PREVIOUS AND CURRENT IFF PATCH DESIGNS..... | 11 |
| C. | EQUIPMENT AND EXPERIMENTAL SETUP..... | 15 |
| D. | INITIAL TESTS OF NEW EMITTER MATERIAL. | 18 |
| E. | NEED FOR BETTER MATERIALS | 26 |
| III. | ANALYSIS OF NEW EMITTER MATERIALS FOR USE IN NEXT GENERATION PATCHES | 27 |
| A. | NEW EMITTER MATERIALS..... | 27 |
| B. | TURN-ON BEHAVIOR OF NEW EMITTER MATERIALS..... | 30 |
| C. | EFFECTS OF COMPLIANCE VOLTAGE | 34 |
| D. | THE BEST MATERIAL..... | 37 |
| IV. | ANALYSIS OF TRANSIENT EFFECTS IN P-OLED MATERIALS..... | 39 |
| A. | I-V CURVES | 39 |
| B. | VOLTAGE VS. INTENSITY DURING THE TURN-ON PERIOD | 41 |
| C. | MEASUREMENT OF TRANSIENT EFFECTS DURING TURN-ON... | 42 |
| V. | CONCLUSION AND REMARKS | 47 |
| A. | NEW MATERIAL FOR THE NEXT GENERATION DEVICE | 47 |
| B. | INITIAL MEASUREMENTS OF TRANSIENT PHENOMENA | 47 |
| C. | FURTHER RESEARCH..... | 48 |
| | LIST OF REFERENCES | 49 |
| | INITIAL DISTRIBUTION LIST | 51 |

THIS PAGE INTENTIONALLY LEFT BLANK

LIST OF FIGURES

| | | |
|------------|--|----|
| Figure 1. | Example of IR reflectors worn by US soldiers ^[2] | 3 |
| Figure 2. | IR reflector illuminated by IR light source. | 3 |
| Figure 3. | Pheonix IR Beacon [3]..... | 4 |
| Figure 4. | The majority of third generation night vision devices primarily detect IR light [5]..... | 5 |
| Figure 5. | Band Energy Diagram of a Light Emitting Diode [9]. | 8 |
| Figure 6. | P-OLED construction diagram [6]..... | 9 |
| Figure 7. | Add-Vision p-OLED design [10]..... | 10 |
| Figure 8. | Sample coupon provided by Add-Vision..... | 11 |
| Figure 9. | Spectral output of yellow emitter with 3 mA driving current..... | 12 |
| Figure 10. | IR image of emitter area. | 12 |
| Figure 11. | Second generation IIFF patch. | 13 |
| Figure 12. | Third generation IIFF patch. | 14 |
| Figure 13. | Image of two IIFF third generation patches at 400 m..... | 14 |
| Figure 14. | Block diagram of experimental setup. | 16 |
| Figure 15. | Ocean Optics USB-4000 spectrometer. | 16 |
| Figure 16. | Sample in place and ready for data to be collected. For the actual experiments this would be covered to block interfering light..... | 17 |
| Figure 17. | Overall setup. | 17 |
| Figure 18. | Intensity as a function of time and wavelength of yellow p-OLED material. | 19 |
| Figure 19. | Intensity as a function of time and wavelength after five minutes 3 mA DC current. | 20 |
| Figure 20. | Intensity as a function of time and wavelength after five hour rest period..... | 20 |
| Figure 21. | Intensity vs. time for initial turn-on, after a 5 minute warm-up at 3 mA and after a 5 hour rest period with no activations for the Covion yellow material | 21 |
| Figure 22. | Spectral response of the Covion Yellow emitter and two concentrations of mixture. | 22 |
| Figure 23. | Intensity as a function of time and wavelength for the initial turn-on of 2:1 (left) and 3:1 (right) mixtures. Note the difference in the intensity scales on the Z-axis. | 23 |
| Figure 24. | Intensity as a function of time and wavelength after five minute warm-up for 2:1 (left) and 3:1 (right) mixtures. Note the difference in the intensity scales on the Z-axis..... | 23 |
| Figure 25. | Intensity as a function of time and wavelength after 5 hour rest period for 2:1 (left) and 3:1 (right) mixtures. Note the difference in the intensity scales on the Z-axis..... | 24 |
| Figure 26. | Intensity vs. time for initial turn-on, after a 5 minute warm-up at 3 mA and after a 5 hour rest period with no activations for the Covion yellow material | 24 |

| | | |
|------------|--|----|
| Figure 27. | Intensity vs. time for initial turn-on, after a 5 minute warm-up at 3 mA and after a 5 hour rest period with no activations for the Covion yellow material | 25 |
| Figure 28. | Night vision image of current patch (left,) 2:1 (yellow:red) sample (middle) and Covion Yellow sample (right.)..... | 27 |
| Figure 29. | Overall spectral response of different mixtures, all with Cathode A..... | 28 |
| Figure 30. | Overall Intensity for 1:1 and 4:1 mixtures with Cathode A | 29 |
| Figure 31. | Overall Intensity for the 4:1 mixture with Cathode A and Cathode B | 29 |
| Figure 32. | 1:1 concentration, Cathode A | 31 |
| Figure 33. | 1:1 concentration, Cathode B..... | 31 |
| Figure 34. | 4:1 concentration, Cathode A. | 32 |
| Figure 35. | 4:1 concentration, Cathode B..... | 32 |
| Figure 36. | Pure yellow sample, Cathode A..... | 33 |
| Figure 37. | Intensity vs. Time for the 4:1 mixture with both Cathode A and Cathode B at the 700 nm wavelength..... | 33 |
| Figure 38. | Intensity vs. Time for the 4:1 mixture with Cathode B and the Covion yellow material at 700 nm..... | 34 |
| Figure 39. | Intensity as a function of time during current bias pulsing for 4:1 Cathode A vs. 4:1 Cathode B..... | 35 |
| Figure 40. | Intensity as a function of time during current bias pulsing for 1:1 Cathode B vs. 4:1 Cathode A | 36 |
| Figure 41. | I-V curves for 4:1 Cathode B material..... | 40 |
| Figure 42. | Peak intensity (arbitrary units) and Voltage (V) as a function of time during the turn-on of 4:1 Cathode B material..... | 42 |
| Figure 43. | Peak intensity (normalized to maximum value after warm-up) vs. time (s) of the 4:1 Cathode B material | 43 |
| Figure 44. | Peak intensity (normalized to the maximum value after warm-up) vs. time (s) of the 1:1 Cathode A, 1:1 Cathode B and 4:1 Cathode B materials. | 44 |

ACKNOWLEDGMENTS

Many thanks are due to Matt Wilkinson, Devin MacKenzie, Yuka Yoshioka and Eric Jones at Add-Vision, Inc. for their superb production of quality samples to test and commitment to providing newer, and better, materials for use in the IIFF device. None of this would have been possible without their contribution.

This work was supported in part by a contract from the Rapid Reaction Technology Office of the Office of the Secretary of Defense, DDR&E.

I would like to acknowledge the prior work of Captain Patrick Williams, USMC and Lieutenant Johannah Schumacher, USN.

The technical assistance of Sam Barone and the fabrication efforts of George Jaksha at NPS contributed immensely to this research and enabled superb experimental design.

Professor Pete Crooker at NPS was more than a second reader. His experience as a physicist helped me understand the more difficult concepts of this subject area immensely.

I owe the success of this thesis to Professor Nancy Haegel, my thesis advisor. Her patience, determination and encouragement were instrumental to not just the success of this thesis, but my growth as a physicist. Any of my future successes in Physics will be because of her.

THIS PAGE INTENTIONALLY LEFT BLANK

I. INTRODUCTION

A. WHAT IS IFF?

Identification Friend or Foe (IFF) is a group classification of devices which use coded radio signals to rapidly identify unknown aircraft, ships or vehicles, increasing situational awareness and providing another indicator for the classification of targets. Conventional IFF found on commercial and military platforms is based on a “interrogate and respond” system that allows one platform to broadcast a coded signal (interrogate) and the responding platform to reply (squawk) with their own coded signal (response) that includes information “modes” such as mission, unit code, air traffic control designation, altitude and cryptographically secured friend/foe statement.

IFF was first used in WWII by the Royal Air Force in 1939, and the method of operation remained fundamentally the same until the early 1990s. The IFF transponder on the interrogated ship or aircraft would respond to a coded frequency in the interrogating ship’s radar. Modern systems rely on a separate transponder and are independent of the navigational radar system.

B. CURRENT IFF DEVICES IN USE

IFF interrogators and transponders are large hardware devices that allow for the sending and receiving of information, as well as control interfaces that allow the user to program specific IFF modes to squawk, as well as interface with military cryptographical systems for modes that require encrypted signals [1]. Military ships and aircraft have access to all IFF modes, while civilian aircraft and traffic controllers are limited in their use.

Civilian aircraft only have access to two IFF modes. Mode 3 is a commercial designation, designated by the air traffic controller (ATC,) providing immediate identification of the aircraft by other ATCs. They also squawk Mode C, which reports the aircraft’s altitude.

Military platforms, however, have access to a number of other Modes. They can squawk Mode 1 (mission designator,) Mode 2 (unit designator,) Mode 3 (same as civilian Mode 3,) and Mode 4 (friend/foe reply.) More modern IFF systems now have more complex interrogation replies which include GPS position and other selective features [1].

Individual IFF devices for soldiers are more rudimentary in nature. Because of weight limitations, large hardware systems are not feasible for every soldier. Furthermore, crypto security prevents individual soldiers from carrying sensitive information that could compromise IFF security for the military forces at large. Because of that, individual IFF solutions, thus far, have been limited to infra-red (IR) reflective tape or IR beacons.

Figure 1 is an example of IR reflective tape, or Glo-tapeTM, which is either a reflective patch or strip worn on the uniform that only reflects IR light. If an IR beacon or targeting laser illuminates the friendly target wearing the reflective tape the strong reflection will be an immediate indication that the targeted person is a friendly unit. Modern night vision systems primarily see in the IR region, allowing targeting lasers and reflective patches/beacons to be invisible to the naked eye, yet visible through night vision devices.



Figure 1. Example of IR reflectors worn by US soldiers^[2]

Figure 2 shows a single IR reflective patch viewed at 100 m and illuminated with the IR flood source from an AN/PVS-14 night vision monocular. The image was taken using a video camera equipped with a generation III night vision image intensifier.

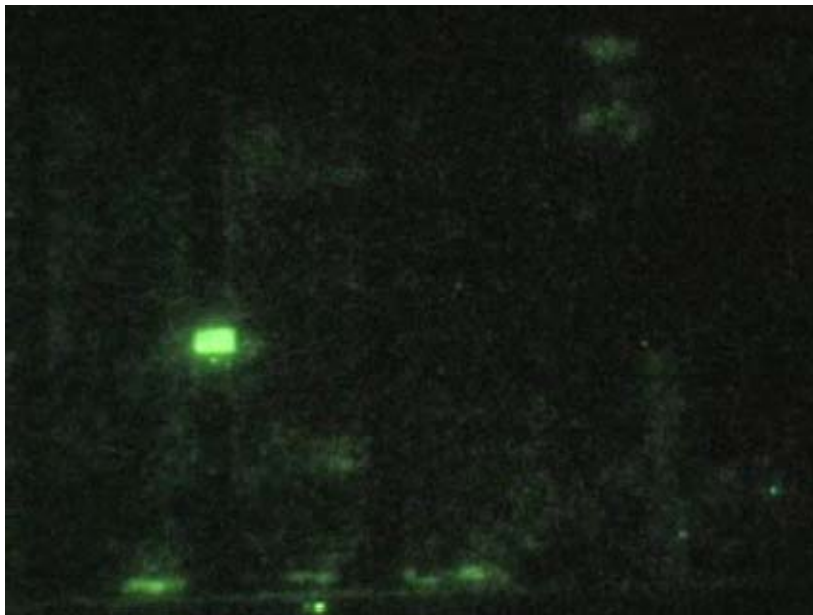

Figure 2. IR reflector illuminated by IR light source.

IR beacons are IR emitters, battery powered, attached to the uniform by Velcro. They emit a constant IR signal, pulsed so that anyone looking through a night vision device can distinguish the IR signal from background lighting. The beacons are usually attached to a 9V battery source and emit IR light from an LED source. Figure 3 shows a Phoenix IR beacon which has a maximum viewing range of 4 km [3].



Figure 3. Phoenix IR Beacon [3]

C. NEED FOR TRIGGERED IIFF

At the turn of the century, access to night vision device (NVD) technology, especially third generation NVDs, was limited. However, in recent years, proliferation of night vision technology is growing, if not already widespread. Reports of terrorist organizations obtaining NVDs [4] are limited in the open press, but the mere fact that some are obtaining modern night vision equipment is a direct threat to US and Allied forces that are dependent on the ability to be “invisible” at night. Until recently, military units operating under the cover of darkness, using IR (invisible to the naked eye) Identification devices only seen through NVDs, had the advantage of being able to operate at night without fear of detection. Now, with the proliferation of NVD devices

among enemy combatants, they are more likely to be detected under cover of darkness with IR beacons or reflectors, and the problem will continue to grow as the degree of proliferation increases.

Furthermore, given the increasing number of IR signatures in the battle space, it is a limitation that a simple reflector does not have a distinct signal, so that a simple reflection is potentially lost in the background. A triggered device, delivering a pulsed response, will allow for quicker identification in the rapid pace of nighttime operations. The speed and lethality of modern weapons necessitates an immediate and easily discernable response. Figure 4 shows the primarily IR spectral response of the latest generation of night vision systems.

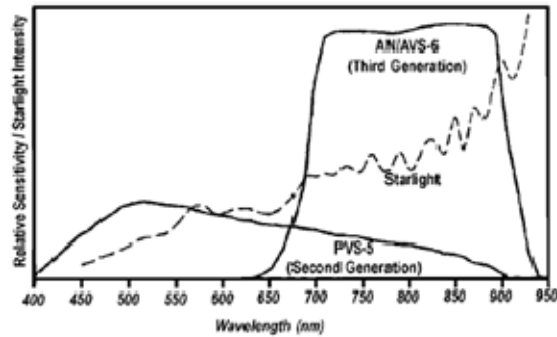

Figure 1-3. Third Generation (GEN-III) I2 Tube Technology

Figure 4. The majority of third generation night vision devices primarily detect IR light [5].

Conventional radio frequency IFF devices require large, expensive hardware unsuitable for individual issue that prohibits its use among individual ground soldiers. However, to counter the proliferation of NVDs, some form of reactive IFF technology will be an important factor in upcoming conflicts in the mitigation of shooter-on-shooter fratricide. The legacy IFF “interrogate and respond” system is the only practical solution, and the challenge lies in creating such a system using smaller, cheaper technology and building on current technology in use by U.S. and Allied forces.

An effective Individual IFF (IIFF) system will have several requirements. First, it will have to be covert (e.g., operate in the IR region and be undetectable to the naked eye.) Secondly, it will need to have a triggered response (similar to conventional IFF's interrogate and respond system) in order to maintain covertness to even night vision when not triggered. Thirdly, it must be rugged, durable, lightweight and flexible. Lastly, it will need to seamlessly integrate into current standard operating procedures (SOP) requiring minimal changes, if any, to existing SOP.

Light Emitting Polymers (LEP) are new materials that can be used in the fabrication of these triggered IIFF devices. Unlike traditional diodes, they are thin film emitters that are lightweight and flexible and can be used to create ultra-thin devices that can be easily worn on the uniform in addition to (or in place of) traditional IR reflective tape or IR beacons. However, the use of LEPs in this application requires research into both their infrared emission and their short-term transient response, topics not addressed for their more common commercial applications.

D. THESIS OVERVIEW

In this work, research is presented into new polymer Organic Light Emitting Diodes (p-OLED) for use in the IIFF patch. Chapter I described IFF and the need for triggered IIFF patches. Chapter II contains background information on p-OLED emitters, current generation IIFF patches, current emitter specifications and an explanation of the need for newer, brighter and faster IR-emitting materials. Chapter III analyzes these newly synthesized materials in a manner similar to their actual application in the device and proposes a candidate material for the next generation of IIFF patches currently being developed for testing by US Special Operations Command under a Technology Transition Initiative of the office of the Secretary of Defense. Chapter IV presents research on specific material properties, to include overall brightness, response time(s) and efficiency. Chapter V will conclude and make suggestions for future work.

II. IFF BACKGROUND, CURRENT DEVICES AND THE NEED FOR NEW MATERIALS

A. WHAT IS A P-OLED?

Polymer organic light emitting diodes (p-OLED) were first constructed in the late 1970s [6]. At that time, it was discovered that conjugated polymers could conduct electric charges, enabling their use as conductors and, more importantly, semiconductors. In fact, the 2000 Nobel Prize in Chemistry went to Alan Heeger for “the discovery and development of conducting polymers [7].” Alan Heeger began his career with a PhD in Physics from University of California, Berkley, and continued his work in conducting polymers at the University of Pennsylvania where he focused on interdisciplinary studies between Chemistry and Physics, resulting in his Nobel Prize [8].

Diodes are electronic devices consisting of a semiconductor doped to create a p-n junction. In a light emitting diode (LED,) holes are injected into the valence band and electrons are injected into the conduction band under forward bias. These holes and electrons recombine to produce light. The wavelength of light is determined by the band-gap energy of the material (i.e., the potential difference between the conduction and valence bands in the doped semiconductor material.) Figure 5 shows the band-energy diagram of a typical semiconductor LED.

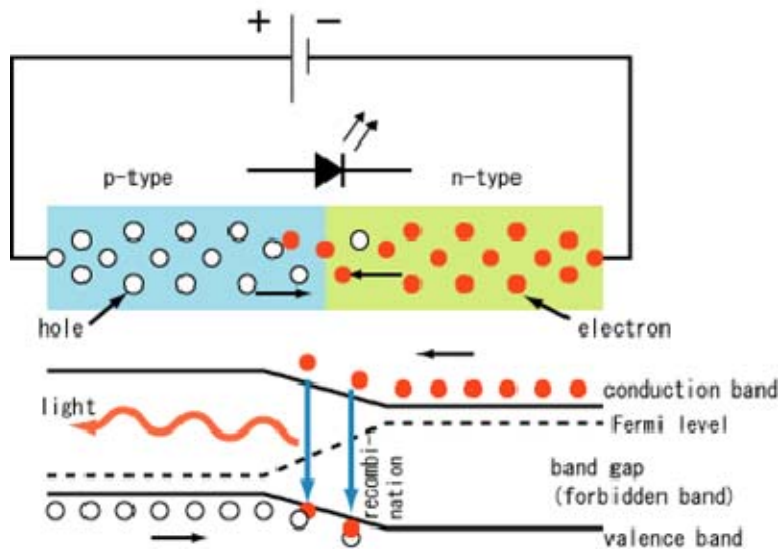

Figure 5. Band Energy Diagram of a Light Emitting Diode [9].

Conjugated organic polymer semiconductors act similar to inorganic LEDs, allowing for their use as polymer organic light emitting diodes. These early p-OLEDs were not very efficient and highly unreliable until the early 1990s when efficient electroluminescence in thin-film p-OLEDs was discovered. Further research into liquid soluble conjugated polymers allowed the light emitting polymer (LEP) to be screen printed, allowing for inexpensive creation of these thin film LEPs in p-OLED devices.

Figure 6 shows how P-OLEDs were originally constructed in a forward layer process, where a hole injection layer, such as poly(ethylene dioxythiophene) or polyaniline, is screen printed onto a indium tin-oxide layer on a rigid glass substrate. Then the LEP layer, based on a conjugated polymer such as poly(2-methoxy,5-(2'-ethyl-hexoxy)-1,4-phenylenevinylene) or methyl-substituted ladder-type polyparaphenylene, is screen printed on the hole injection layer. A top conductive electrode of calcium is vapor phase deposited onto the LEP layer, followed by an aluminum layer [6].

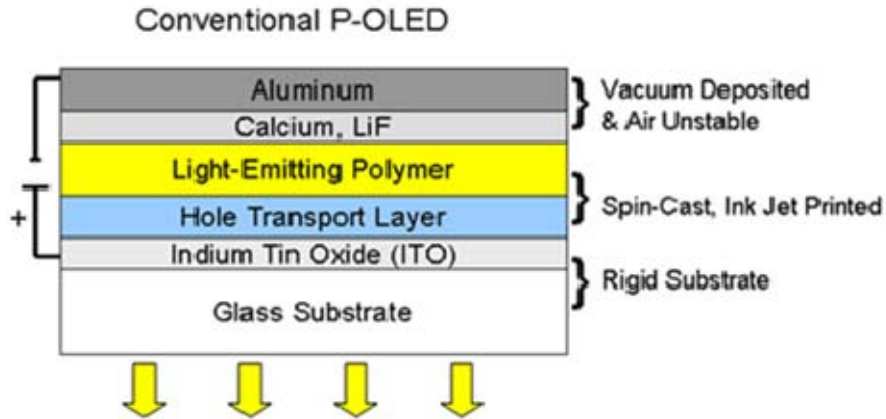

Figure 6. P-OLED construction diagram [6].

In a reverse build construction, the bottom conductive cathode is first vapor phase deposited onto the substrate, followed by the LEP layer, hole injection layer and finally the indium tin-oxide anode [6].

These p-OLEDs are used to create high resolution, high efficiency displays. In a Liquid Crystal Display (LCD) the light is provided by a back-light and the LCD plane filters out much of that light to create an image on the screen. In a p-OLED display the material itself emits light, eliminating the need for a back-light, making the display more power-efficient, increases the viewing angle and reduces the thickness of the display. These displays can be used in a wide variety of applications, including televisions, computer monitors, hand-held devices, cellular telephones and any other device requiring the use of a digital display.

Add-Vision is a company that has developed a unique application for p-OLEDs. Instead of the high-resolution displays that are manufactured using vapor deposition under vacuum, they designed low resolution p-OLED displays are screen-printed in normal atmosphere, eliminating the need for the expensive vapor deposition process, making the displays much less expensive to manufacture. Furthermore, unlike the small molecule OLED displays, these new emitters could be printed on a plastic (PET/PEN) substrate, making them flexible. These displays are not useful in high resolution

applications, but are suited to applications that require very thin and flexible patterned light sources, such as vehicle displays, cellular telephone keypad displays, illuminated advertisements and any device requiring the use of a low-voltage, thin emitter.

Figure 7 shows Add-Vision's design, where they formulated a way to screen print the cathode layer, rather than vapor deposition, enabling the entire p-OLED construction to be conducted in normal atmospheric air in a much less expensive and time-consuming manner than vapor deposition. They use silver for the cathode because it is less reactive than calcium and utilize a plastic substrate with higher oxygen permeability. In this design, with advances in low work function screen printed materials, there is no need for electron and hole transport layers, reducing the design to three layers (anode, LEP, cathode) on a flexible substrate [9].

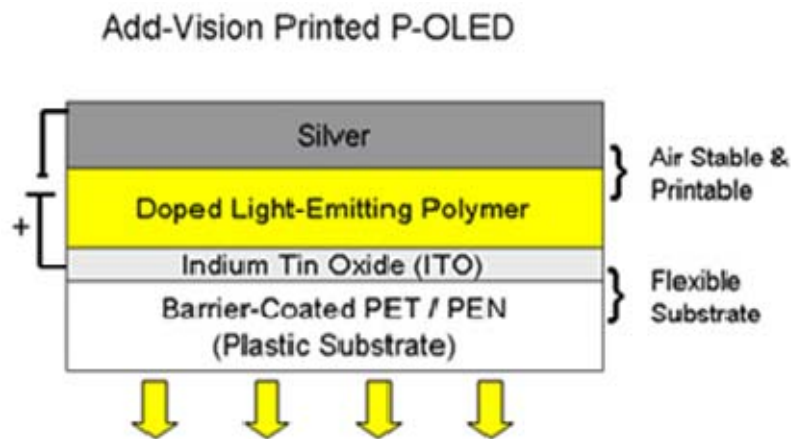

Figure 7. Add-Vision p-OLED design [10]

Unlike semiconductor LEDs, the material is not doped to produce a p-n junction. Rather the LEP material is doped with ions such that when a bias voltage is applied, these ions create a p-n junction within the material. When the p-n junction is created, light can be emitted.

Our research focuses on the optical effects of the optimization of both the cathode design and LEP formulation, resulting in a much faster and brighter p-OLED for use in prototype IIFF patches. P-OLEDs are useful because, unlike traditional LEDs, the p-OLEDs are printed on a thin, flexible plastic substrate allowing for the patch to be

wearable on a uniform in the same manner as the current IR reflective patches. Figure 8 is an image of the sample coupons tested in this experiment. Each coupon contains two 1 cm^2 emitters that share a common positive terminal. One selects which emitter to power by connecting one or both negative terminals.

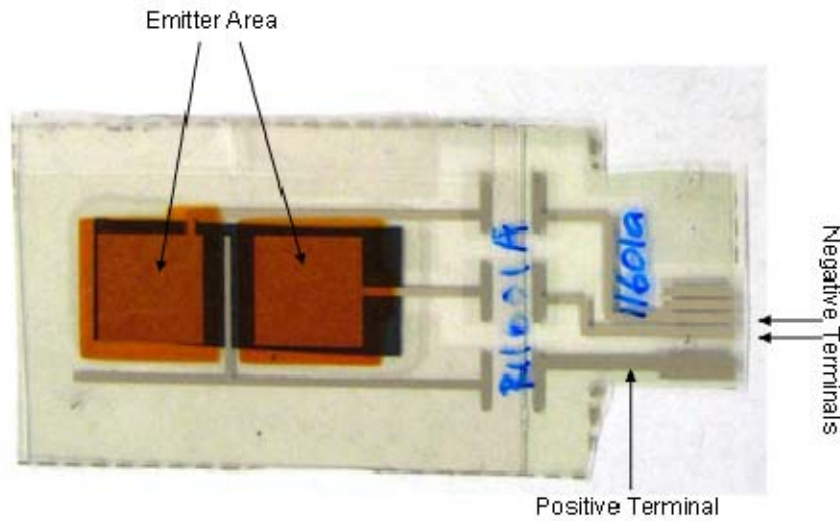

Figure 8. Sample coupon provided by Add-Vision

B. PREVIOUS AND CURRENT IIFF PATCH DESIGNS

All early prototype versions of the IIFF patch use a Covion yellow emitter as the source of IR light. Even though the material emits predominately in the visible range, as seen in Figure 9, there is a tail into the IR (past 700 nm) that was sufficiently bright to be useable. Figure 10 shows the IR output of a prototype IIFF patch.

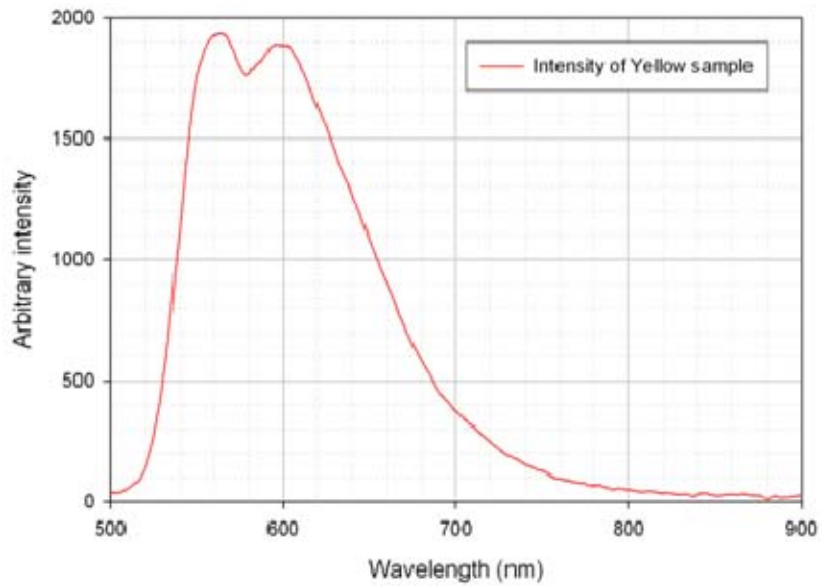

Figure 9. Spectral output of yellow emitter with 3 mA driving current.



Figure 10. IR image of emitter area.

The second generation IIFF patch was constructed using a coin cell battery, circuit board, driver, photodiode sensor and yellow emitter with 700 nm filter encased in a rigid plastic shell. The emitter area is in a chevron pattern with 4 cm² emitter area. It

was compact and wearable, but the lack of replaceable battery required the patch to be discarded once the battery expired. Figure 11 shows a picture of a generation 2 IFF patch.



Figure 11. Second generation IFF patch.

The next generation patch used a similar design, but replaced the coin cell battery with a replaceable AAA battery that was packaged along the short edge of the patch on the sensor side. The device included a selectable “beacon mode” that provided a continuously blinking emission, which required the use of a larger battery. Unfortunately, while allowing the battery to be replaced, the size of the battery made the package harder to wear than the coin cell version. This version had the same sensor and emitter design, but the package was much larger and the large battery enclosure was not flexible. Figure 12 is a picture of the generation 3 IFF patch.



Figure 12. Third generation IIFF patch.

The third generation patch has an effective range tested to 700 m, viewable through an AN/PVS-15B NVD. Testing with video capture devices was effective to 400 meters. Figure 13 was captured as part of a field test of the generation 3 devices.



Figure 13. Image of two IIFF third generation patches at 400 m.

C. EQUIPMENT AND EXPERIMENTAL SETUP

Figure 14 shows a block diagram of the experimental setup. All measurements of the spectral response and transient behavior of new emitter materials are done with an Ocean Optics USB-4000 spectrometer (Figure 15,) which provides time-resolved spectral plots of the light output of the materials. The spectrometer uses a USB interface to connect to a Dell D630 laptop computer running Ocean Optics' Spectrasuite program. The spectrometer operates by passing the light, collected with a 400 μm fiber optics cable through a 25 μm entrance slit, onto a collimating mirror that reflects the light to a diffraction grating which illuminates a 3 kilopixel linear CCD array. Unlike a monochromator, which only detects light at discrete wavelengths, the USB-4000 provides instantaneous measurement of light from 500-1100 nm with 0.3 nm resolution. Furthermore, the high-speed acquisition utility allows for time-dependant spectral response at up to 38 ms sample intervals.

Current pulses are generated using either Keithley 2400 SourceMeter or Keithley 220 programmable current sources. The Keithley 2400 must be programmed via computer interface, but the Keithley 220 is capable of manual program input through the keypad on the front panel.

Voltage measurements are provided by a Tektronix TDS 3032B oscilloscope, which can save waveforms to a disk that can upload to another computer for analysis.

The light output from the sample (Figure 16) is collected and transmitted to the USB-4000 spectrometer (Figure 15) by a 400 μm diameter fiber optics cable. The spectrometer is connected to a laptop computer running Ocean Optics Spectrasuite™ program. Figure 17 provides an overall view of the experimental set-up.

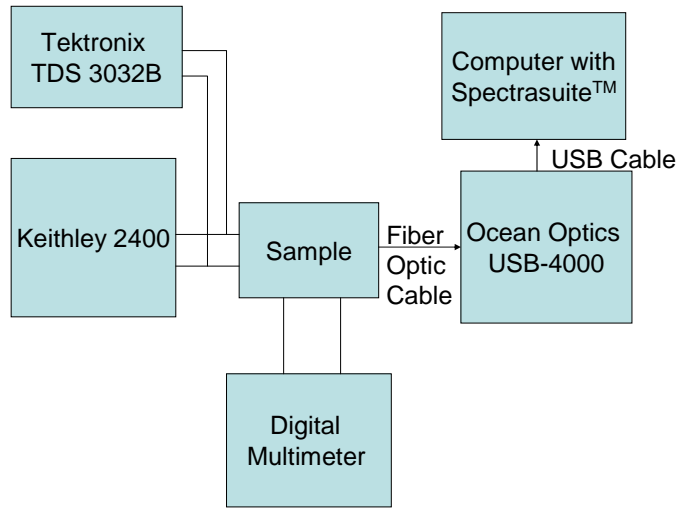

Figure 14. Block diagram of experimental setup.



Figure 15. Ocean Optics USB-4000 spectrometer.

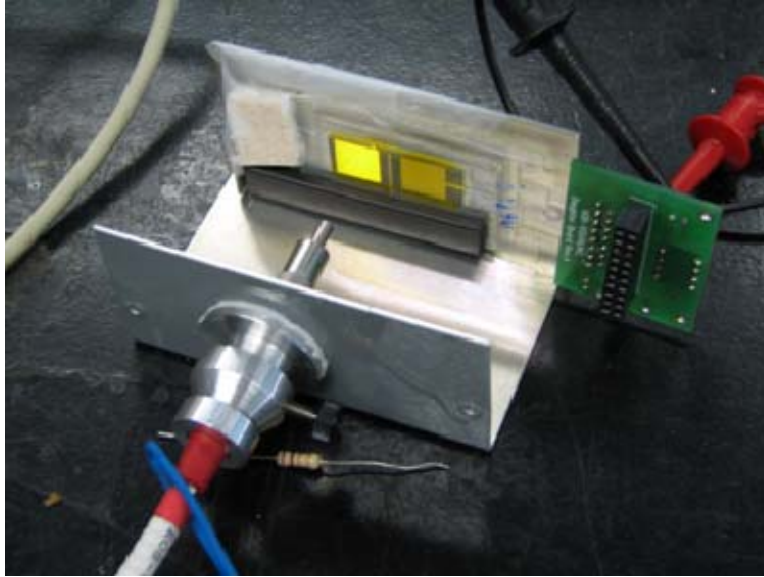

Figure 16. Sample in place and ready for data to be collected. For the actual experiments this would be covered to block interfering light.



Figure 17. Overall setup.

D. INITIAL TESTS OF NEW EMITTER MATERIAL.

The p-OLED material used in the current patch design met design requirements; however there is much room for improvement. Improvements to the current material would include a faster turn-on, overall brightness in the region of interest (700-900 nm) and increased optical efficiency.

The p-OLED material does not respond to electrical charge as fast as a semiconductor LED would. There is a turn-on transient time, in which the device “warms up” to its full maximum intensity. The length of this transient is determined by the materials, both polymer and cathode, used to make the emitter and will be discussed further in Chapter IV. The recombination times that determine semiconductor LED transients operate on a nanosecond time scale, which is nine orders of magnitude faster than the recombination in the p-OLED materials that operate on a time scale measured in seconds.

As one can see in the following graphs, the maximum intensity of the emission for a given drive current responds on a time scale of seconds to minutes. Figures 17-19 are 3-d plots of the Covion yellow emitter with emission wavelength (nm) on the x-axis, time (ms) on the y-axis and intensity (arbitrary units) on the z-axis. Figure 18 shows the intensity produced by an initial series of five 0.5 s pulses over a period of 5 seconds at a current of 3 mA with a 60 V compliance voltage. The current pulses were generated with a Keithley 2400 current source, the data were acquired with an Ocean Optics USB 4000 spectrometer and the graphs were produced with Sigmaplot 9.0.

As can be seen, the first pulse is barely visible on this scale, but by the fifth pulse the intensity is much higher. Figure 19 shows the same response to the same series of pulses, only this time the material has been “warmed up” with a constant 3 mA current for five minutes, and the intensity is much brighter and constant over the five pulses. Figure 20 again shows the response to the same five pulse sequence, but this time the material has been left dormant (no applied bias) for five hours after the five minute warm-up period. The intensity of the emitted light is comparable to measurements taken immediately after warm-up. Earlier data taken by Capt Patrick Williams, USMC show

that the “turn off” transient for optical response from the material is much longer than the turn-on transient [11]. In fact it takes almost 16 hours for the material to return to a “turned off” condition. Figure 21 is a comparison of intensity vs. time for the initial turn-on, after a 5 minute warm-up at 3 mA and after a 5 hour rest period with no activations.

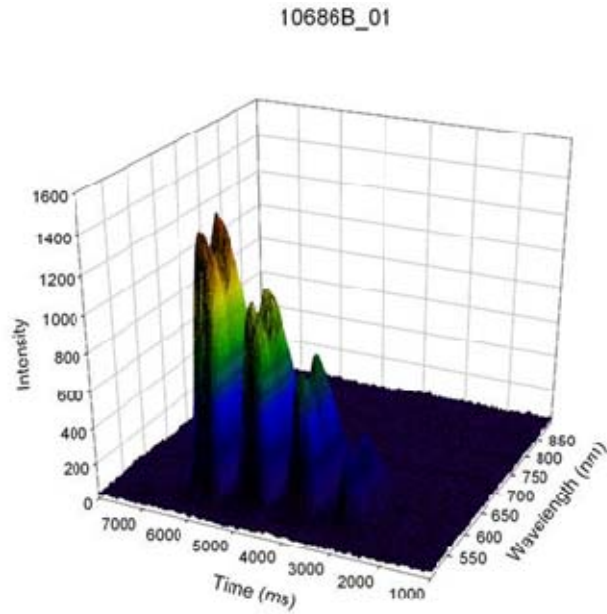

Figure 18. Intensity as a function of time and wavelength of yellow p-OLED material.

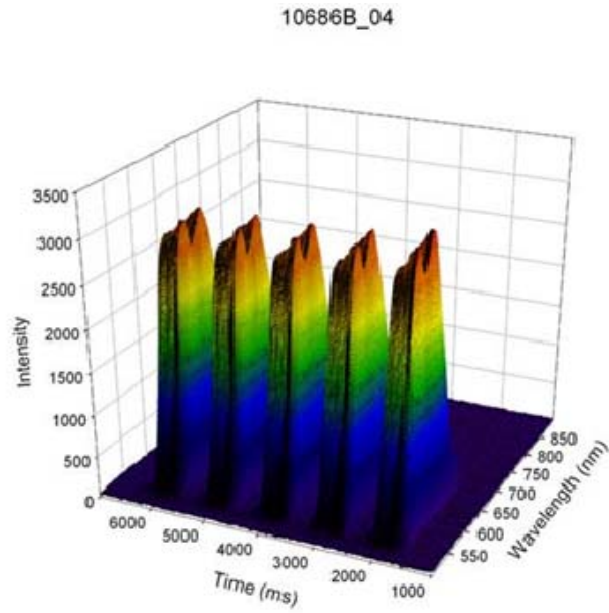

Figure 19. Intensity as a function of time and wavelength after five minutes 3 mA DC current.

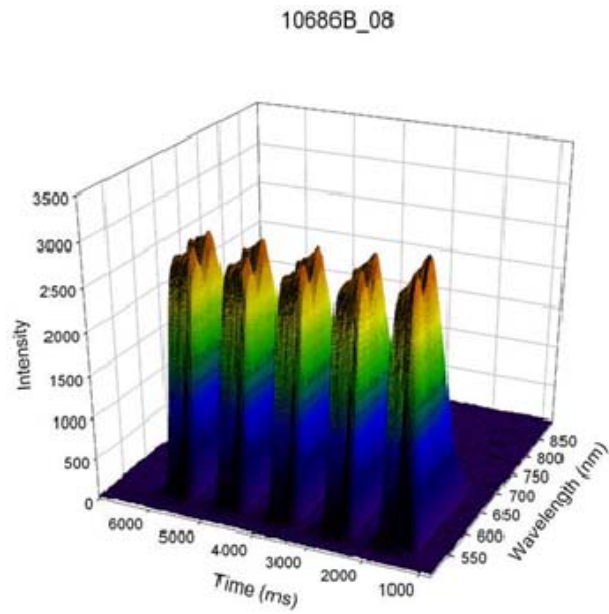

Figure 20. Intensity as a function of time and wavelength after five hour rest period.

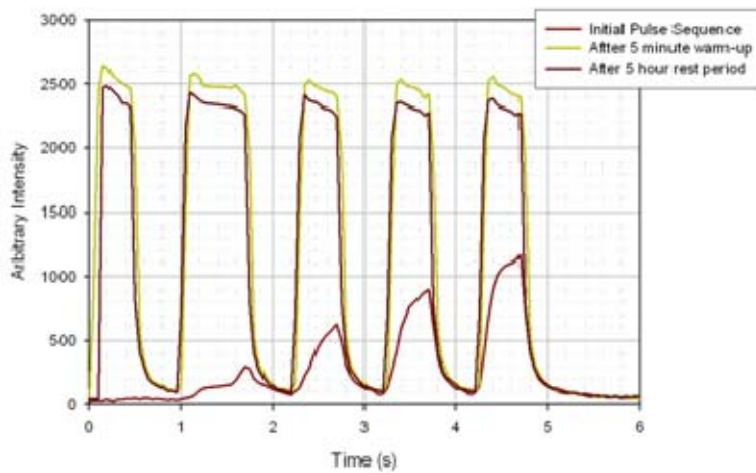

Figure 21. Intensity vs. time for initial turn-on, after a 5 minute warm-up at 3 mA and after a 5 hour rest period with no activations for the Covion yellow material

The yellow emitter is sufficiently fast, however the majority of non-IR light will be filtered out, resulting in low effective IR efficiency. Optimized performance for this application requires a stronger IR emitter. Add-Vision first produced a screen-printed red emitter for enhanced IR emission in 2007. This emitter has a much lower overall intensity, but the intensity in the IR was increased significantly. However, the material stability and turn-on transient time were not suitable for use in the IIFF patches.

The next emitter tested was a mixture of the red and yellow material. The goal was to produce an emitter that exhibited the transient behavior of the yellow material with the wavelength response of the red material. The initial wavelength response tests looked promising. We tested two mixtures; sample 9780B is a 2:1 (yellow:red) mixture and sample 9784A is a 3:1 mixture. Sample 10686B (Covion Yellow) is the latest version of the yellow emitter. Figure 22 shows the spectral response of these new materials compared to the original Covion yellow.

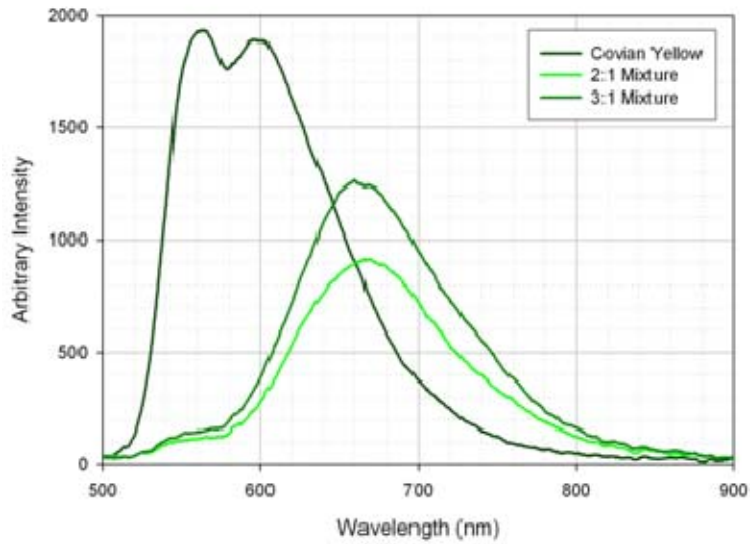

Figure 22. Spectral response of the Covian Yellow emitter and two concentrations of mixture.

From the data in Figure 21, the 2:1 concentration is 2.4 times brighter in the 700-900 nm range, and the 3:1 concentration is 4.0 times brighter in the 700-900 nm range based on numerical integration of the spectral response. What is surprising is the mixture with the higher concentration of yellow material is actually brighter in the IR than the one with less yellow material.

When the turn-on transient was tested, however, neither sample really matched the speed of the pure yellow sample. Figures 23-27 show the response to the same pulse characteristics and experimental set-up as the pure yellow sample.

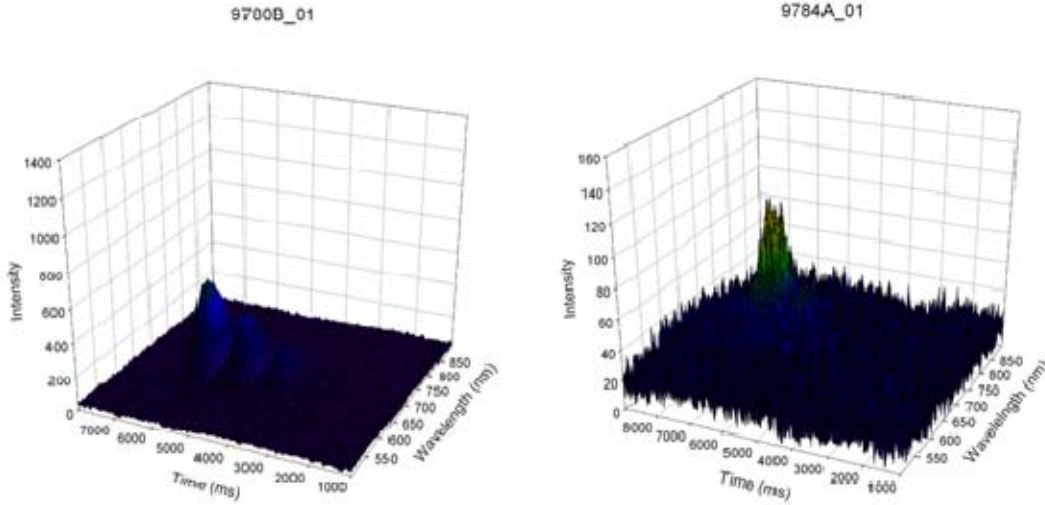

Figure 23. Intensity as a function of time and wavelength for the initial turn-on of 2:1 (left) and 3:1 (right) mixtures. Note the difference in the intensity scales on the Z-axis.

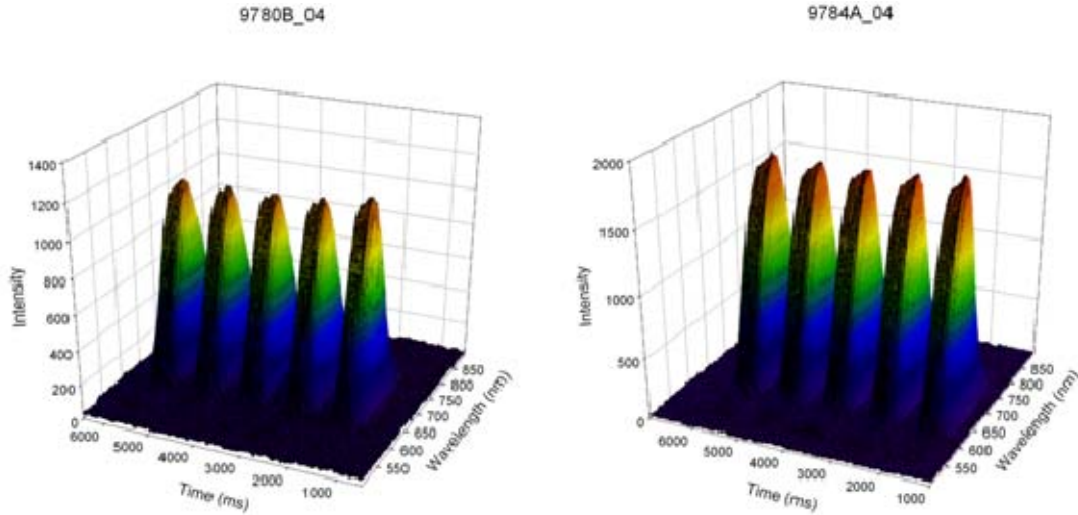

Figure 24. Intensity as a function of time and wavelength after five minute warm-up for 2:1 (left) and 3:1 (right) mixtures. Note the difference in the intensity scales on the Z-axis.

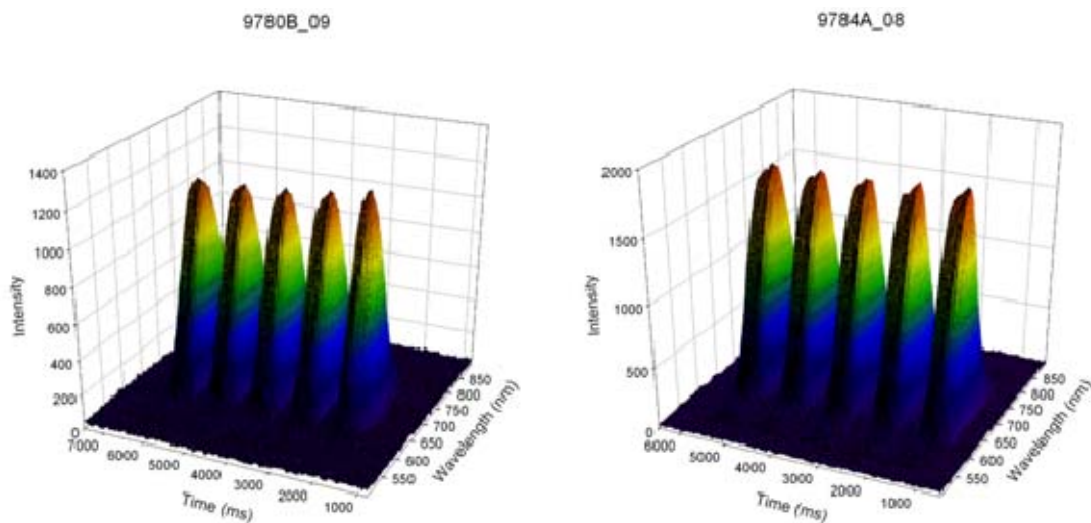

Figure 25. Intensity as a function of time and wavelength after 5-hour rest period for 2:1 (left) and 3:1 (right) mixtures. Note the difference in the intensity scales on the Z-axis.

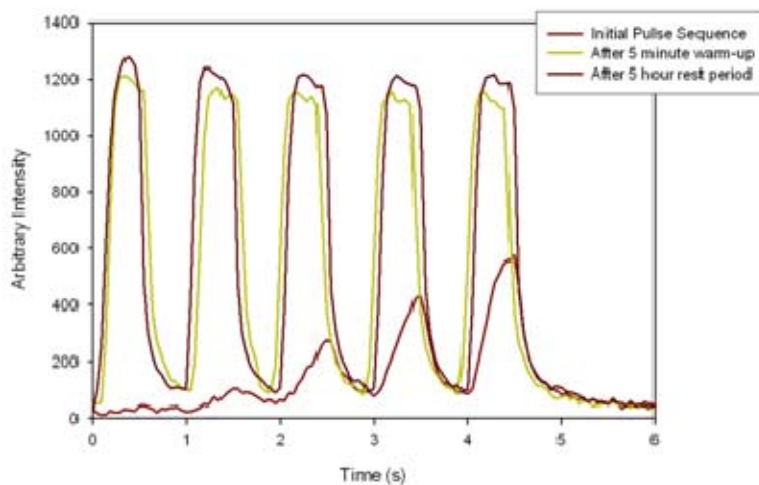

Figure 26. Intensity vs. time for initial turn-on, after a 5 minute warm-up at 3 mA and after a 5 hour rest period with no activations for the Covion yellow material

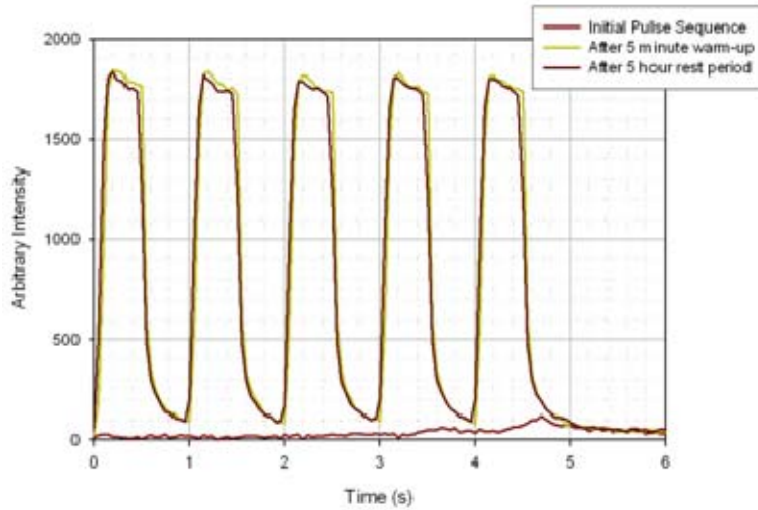

Figure 27. Intensity vs. time for initial turn-on, after a 5 minute warm-up at 3 mA and after a 5 hour rest period with no activations for the Covion yellow material

As one can see, both mixtures exhibited the same turn-off characteristics as the yellow, but the turn-on transient behavior was much slower. For the overall brighter 3:1 mixture, the turn-on was slower. At this point selecting either mixture for the IIF application would require the device to perform its own initial warm-up activation to insure that the patch would be visible if triggered in the field. The efficiency of the red sample in terms of optimized spectral response was counteracted by the inefficiency of needing this warm-up activation.

A 4:1 (yellow:red) sample was also provided, and initial testing by Add-Vision was promising, however the material shorted (i.e., defects in the LEP layer allowed electricity to flow directly from the cathode to anode) destroying its diode characteristics.

The results of these tests were very startling. We expected the higher concentrations of yellow to be faster, but dimmer in the red region. However, the overall intensity in the red region was *brighter* with a higher concentration of yellow sample, but the turn-on characteristics were *less* like the yellow with increasing concentration of yellow in the mixture. The electro-optical performance of the mixtures is clearly not linear variations between the “yellow only” and “red only” properties.

E. NEED FOR BETTER MATERIALS

Additional samples and a better understanding of what was happening in both the LEP layer and LEP-metal interface are required to determine the optimum concentration for a fast, bright material for use in the patch. The yellow, 2:1 or 3:1 materials would each result in a compromise. Either the material would be fast and dim, or slow and bright. The initial tests show that the yellow material would require almost no warm-up, but have minimal emission in the IR. The 3:1 concentration would be much brighter in the IR, but require a turn-on sequence that would be a drain on potential battery life. It seems that the 2:1 concentration would make the best compromise, as it is significantly brighter with an acceptable turn-on, but compromise is not the preferred solution. A combination of materials is needed that is both faster and brighter.

III. ANALYSIS OF NEW EMITTER MATERIALS FOR USE IN NEXT GENERATION PATCHES

A. NEW EMITTER MATERIALS

In Chapter II, mixtures of red and yellow emitter materials were analyzed in an effort to realize the turn-on benefits of the yellow material with the wavelength response of the red material. The initial batch of mixtures had surprising results. The mixture with the higher concentration of yellow produced more light in the IR region, but had a much slower turn-on than the mixture with the higher concentration of red. We took our experimental set-up to Camp Roberts to produce actual night vision images of the new materials to confirm our lab results, and the results were consistent. We used the Micro CCD program to analyze the intensity of the samples in the photographs, and the yellow sample matched the intensity of the current patch (when the intensity was corrected for differences in emitter surface area) and the 2:1 sample was more than twice as bright. Figure 28 is the image we analyzed.

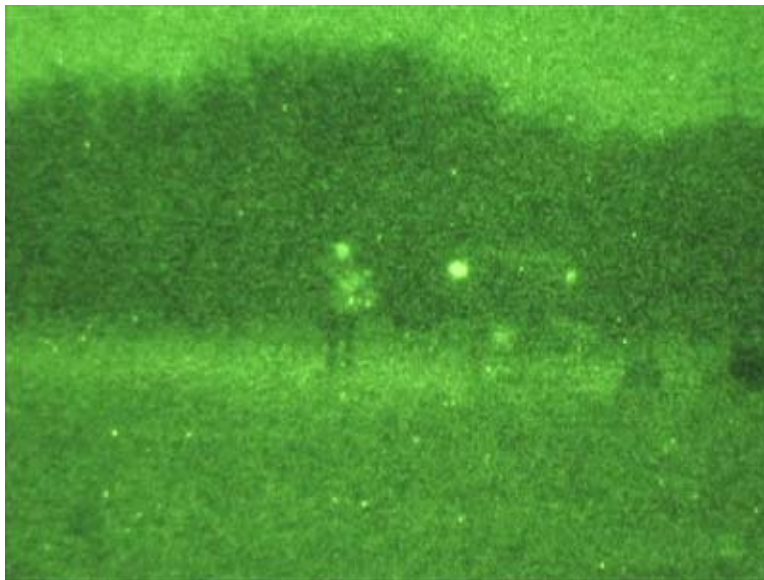

Figure 28. Night vision image of current patch (left,) 2:1 (yellow:red) sample (middle) and Covion Yellow sample (right.)

However, even though the sample is brighter overall, it does not have a fast enough turn-on to eliminate the need for a long initial warm-up, resulting in a significant power drain on the device and reduced battery life. What is needed is a material that is both faster and brighter.

Add-Vision has since produced materials with new concentrations, including 1:1 (yellow:red) and 4:1 (yellow:red) mixtures with two different cathode designs. Cathode A is the original cathode used in the current patch, while Cathode B is a new design that reduces turn-on time, lowers the operating voltage and increases overall brightness. No samples 2:1 or 3:1 samples were produced with Cathode B. Figure 29 shows the spectral response from all four mixtures with Cathode A.

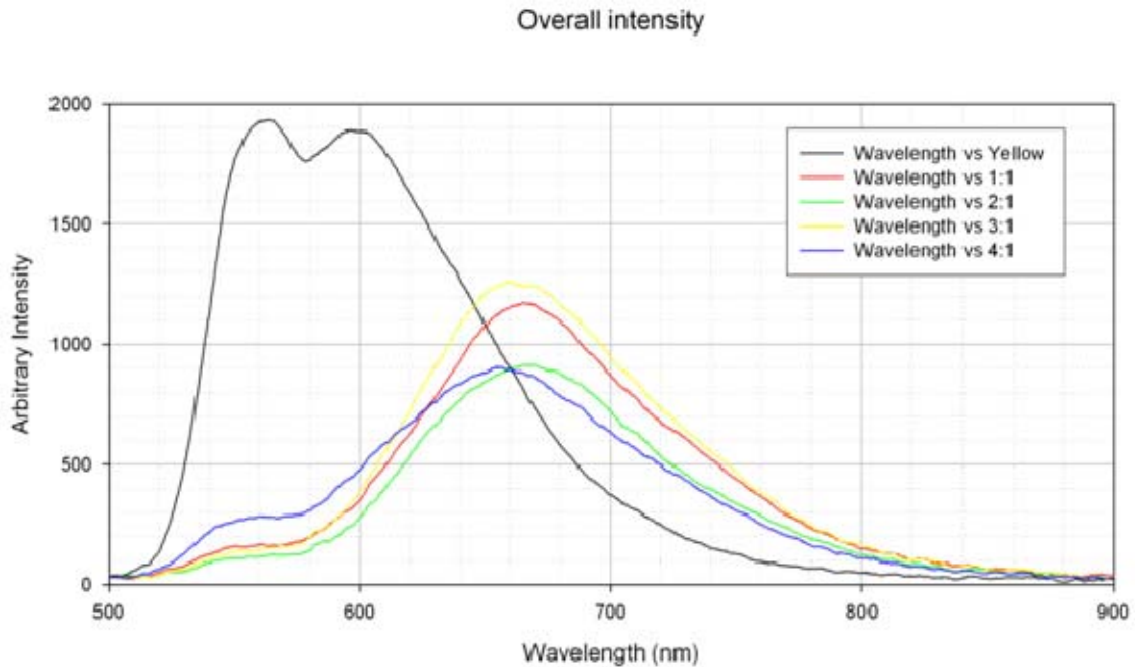

Figure 29. Overall spectral response of different mixtures, all with Cathode A.

As one can see in Figure 29, the 3:1 mixture has a higher intensity in all regions, but the turn-on behavior shown in Chapter II makes it unsuitable for use in the patch. Based on turn-on behavior, the 4:1 and 1:1 concentrations are the best candidates thus far, even if they are not as bright, with this cathode, as the 3:1 mixture. We continued by

comparing the overall spectral response of the 1:1 and 4:1 mixtures for each cathode design. Figure 30 shows the spectral response of the original Covion yellow compared to the 4:1 and 1:1 Cathode A mixtures. Figure 31 shows the spectral response of the 4:1 sample for both Cathode A and Cathode B.

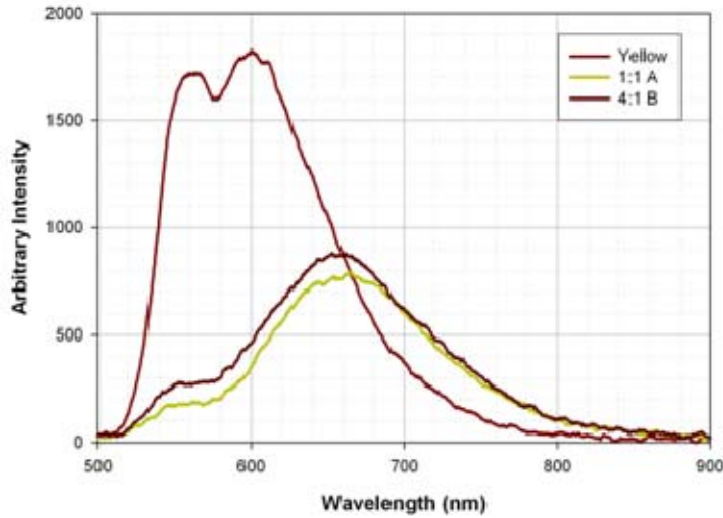

Figure 30. Overall Intensity for 1:1 and 4:1 mixtures with Cathode A

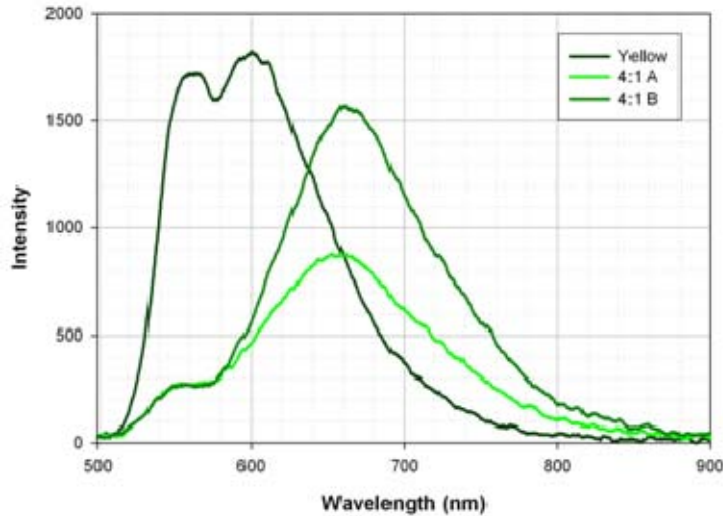

Figure 31. Overall Intensity for the 4:1 mixture with Cathode A and Cathode B

As one can see in Figure 31, Cathode B increases the overall intensity of the mixture significantly, especially in the 700-900 nm region. The 4:1 Cathode B mixture is 4.1 times brighter than the original yellow sample in the IR. Of course, just as important as intensity, is the turn-on behavior.

B. TURN-ON BEHAVIOR OF NEW EMITTER MATERIALS

Figures 32-36 show the turn-on behavior of both mixture concentrations with each Cathode design. The pure yellow mixture only has Cathode A.

Most of the experimental set-up remains the same, however there are some differences. The five pulse sequence was replaced with a 12 pulse, 0.5 s per pulse sequence over a period of 12 seconds and the distance of the fiber probe from the sample was increased slightly to insure accurate collection of the entire sample area. The probe was placed 3 cm from the surface of the sample. The graph layout remains the same; Spectral response on the x-axis, time on the y-axis and intensity on the z-axis. All graphs use the same scale on the intensity axis to show the large difference in behavior between the different samples. Figure 37 shows the time-dependant intensity of the 4:1 material with each cathode design, and Figure 38 shows the time-dependent intensity of the 4:1 mixture with Cathode B and the original Covion yellow material.

1:1 (Y:R) Cathode A

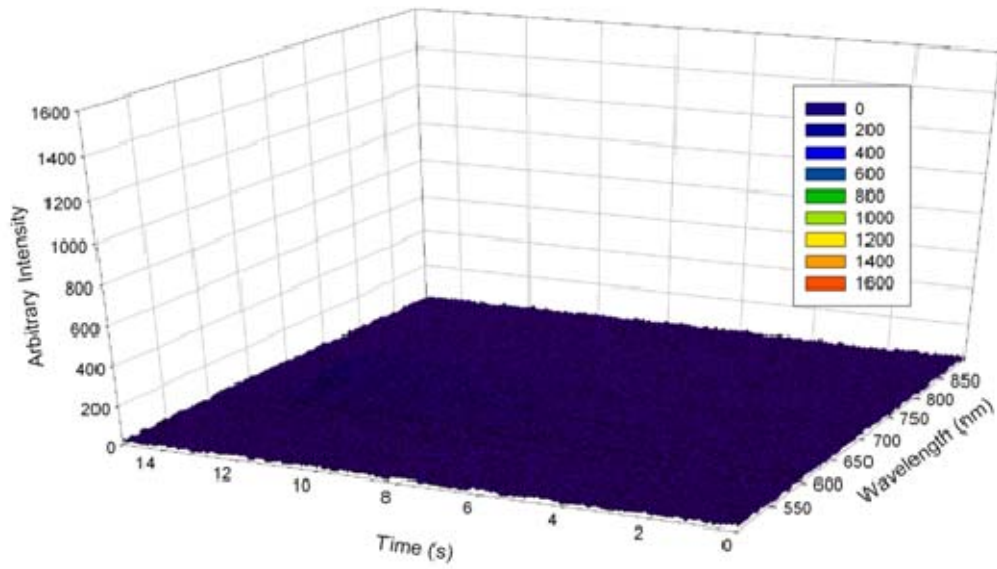

Figure 32. 1:1 concentration, Cathode A

1:1 (Y:R) Cathode B

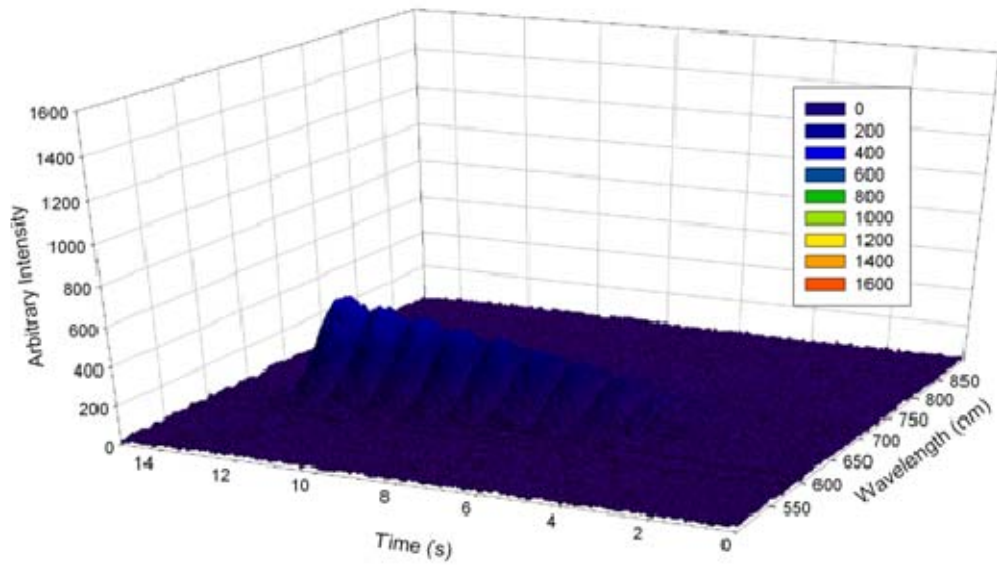

Figure 33. 1:1 concentration, Cathode B

4:1 (Y:R) Cathode A

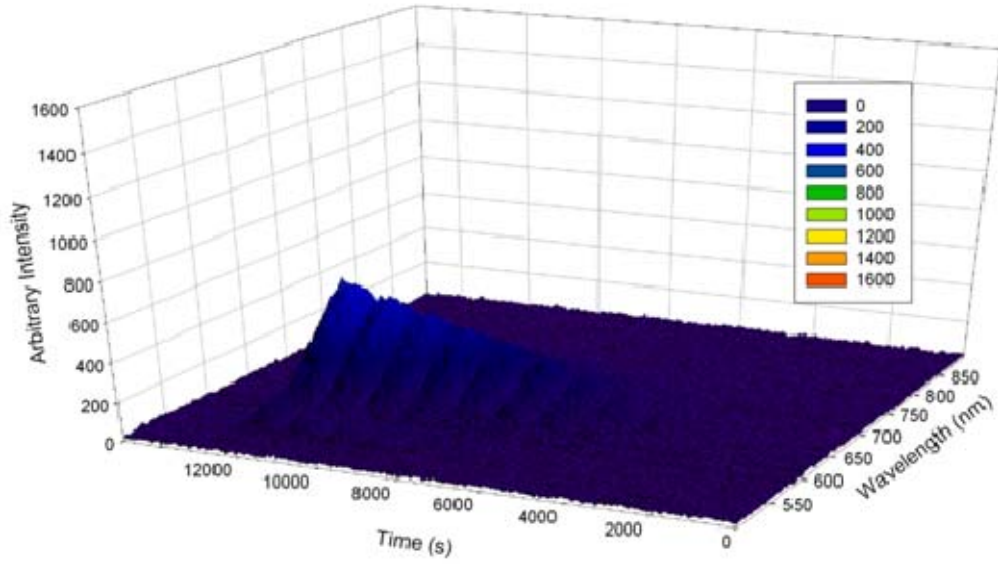

Figure 34. 4:1 concentration, Cathode A.

4:1 (Y:R) Cathode B

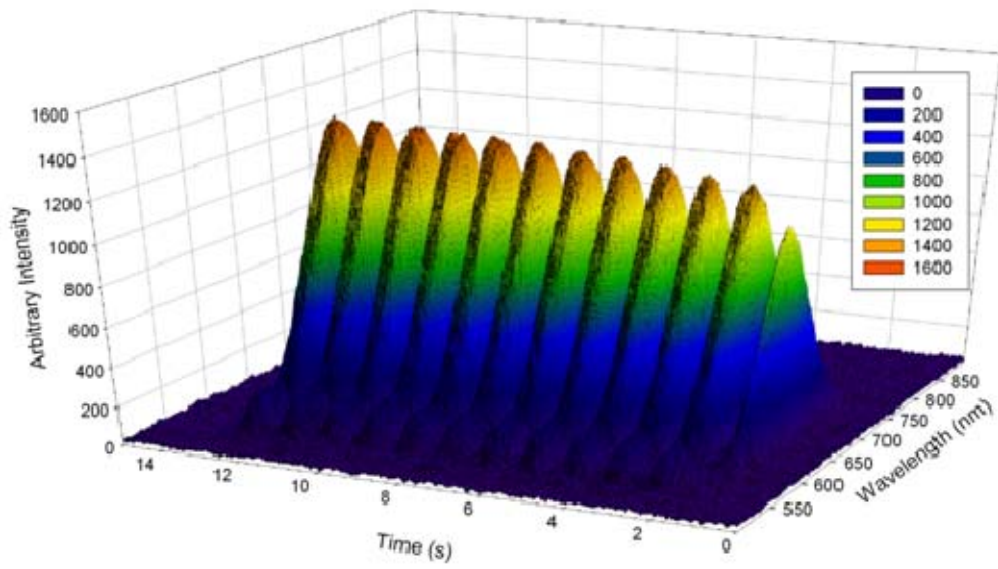

Figure 35. 4:1 concentration, Cathode B.

SYB

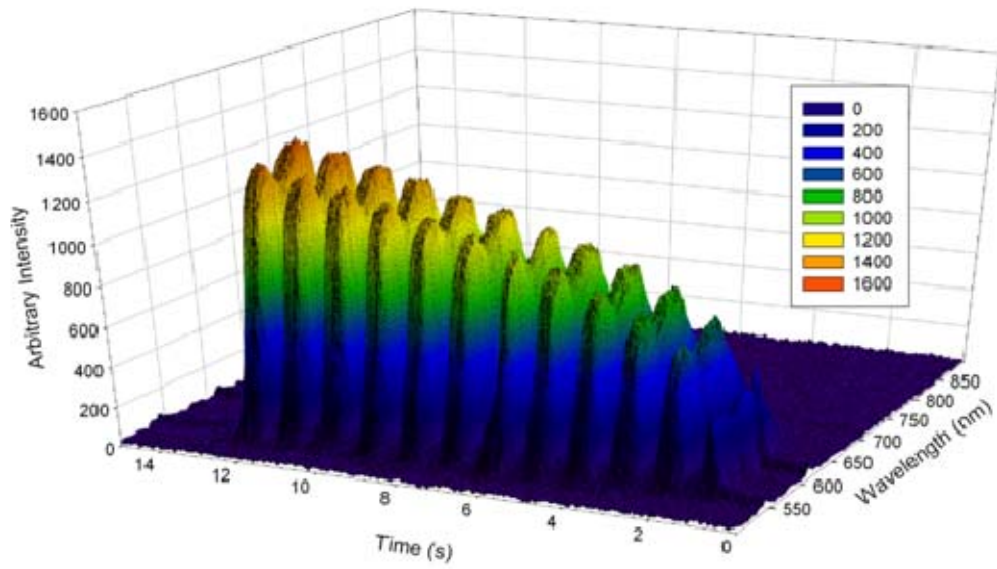

Figure 36. Pure yellow sample, Cathode A

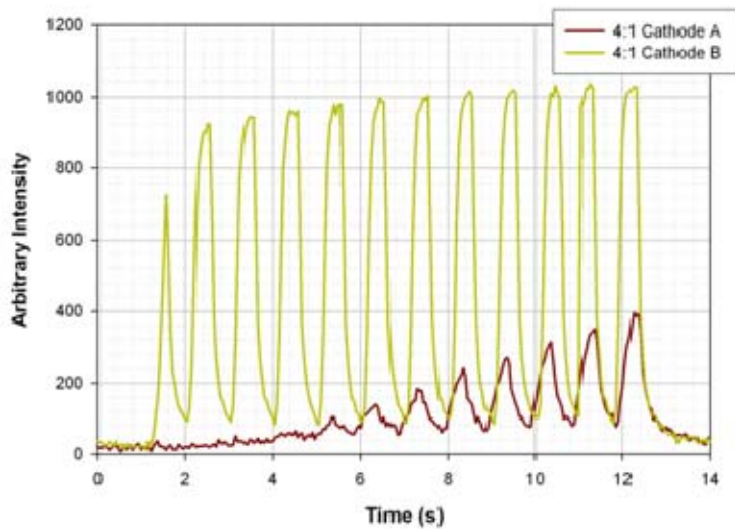

Figure 37. Intensity vs. Time for the 4:1 mixture with both Cathode A and Cathode B at the 700 nm wavelength.

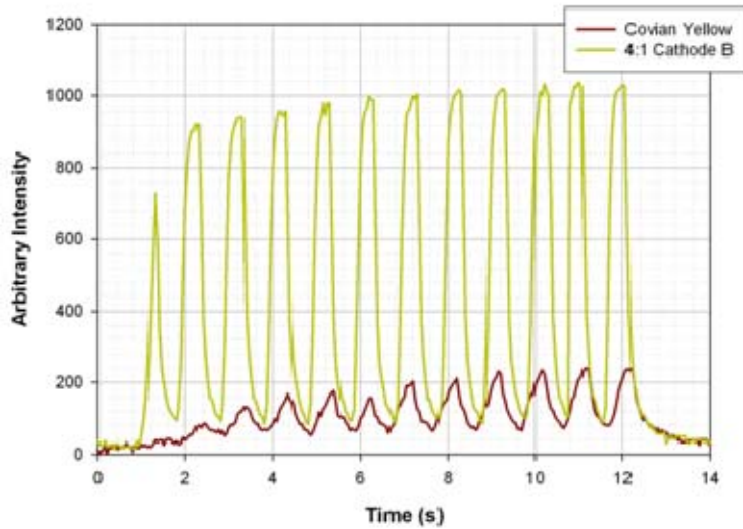

Figure 38. Intensity vs. Time for the 4:1 mixture with Cathode B and the Covian yellow material at 700 nm.

As one can see, there is a clear difference in the transient behavior for both of the mixtures and cathode design. Compared to the other samples with Cathode A, the pure yellow sample is still faster than either mixture concentration; however, the 4:1 Cathode B mixture is still the fastest overall. In fact, it reaches 91% of peak intensity during the second pulse. This is the result needed. Now there is no compromise. The 4:1 Cathode B sample is both brighter in the region of interest and displays faster turn-on characteristics than the original yellow sample.

C. EFFECTS OF COMPLIANCE VOLTAGE

Upon further inspection of all the graphs so far, one may have noticed some odd behavior in these turn-on trends. One would expect the intensity to increase exponentially if a single process was involved, but many of the samples display a linear increase in peak intensity. This is a result of the compliance voltage imposed upon the samples.

Compliance voltage is a set voltage that the current source can not exceed in order to protect the device. A constant current source will only provide the programmed current if the required voltage to do so is less than the compliance voltage. In all cases,

the resistance of the sample decreases during the turn-on of the sample. When the material is initially pulsed, the resistance is so high that the current source cannot source the desired 3 mA. In fact, in many cases the current source was “pinned” at the compliance voltage for many seconds. This effect produces the linear increase in intensity, which reflects variations in both voltage and driving current.

The rate at which material resistance decreases is related to both the sample type and cathode design. Figure 39 is a plot of the peak intensity (671 nm) of the 4:1 sample for each cathode design. The intensity was normalized to the peak intensity for each sample to better illustrate the difference. As one can see, the turn-on of the sample with Cathode B is much faster than Cathode A, even independent of overall brightness.

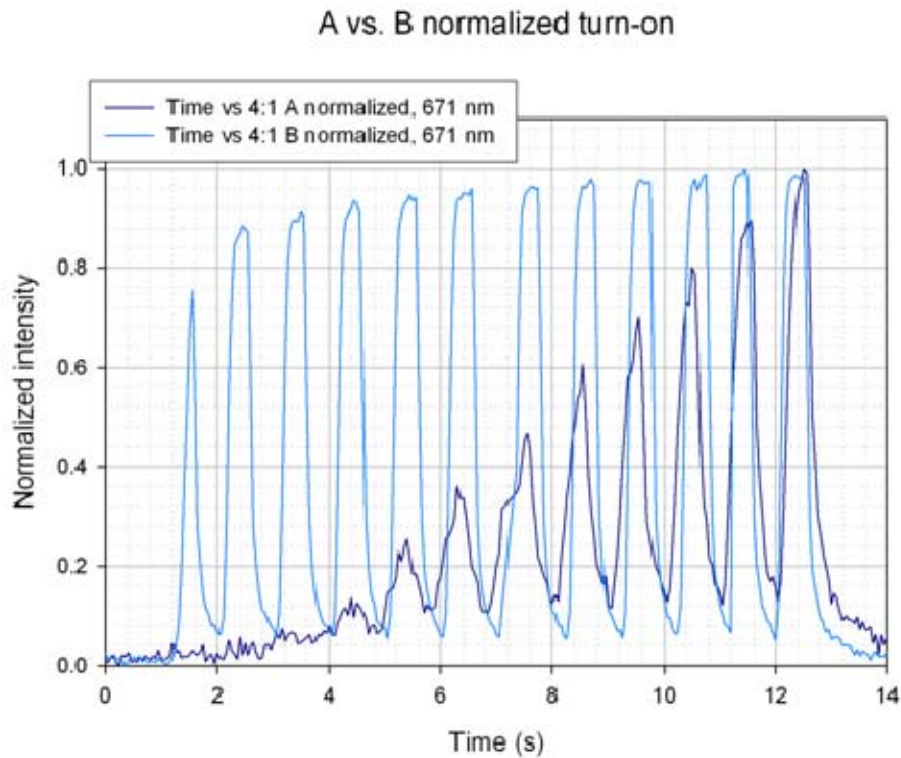

Figure 39. Intensity as a function of time during current bias pulsing for 4:1 Cathode A vs. 4:1 Cathode B.

Figure 40 further illustrates the difference between both sample composition and cathode design. The graph compares the 1:1 Cathode B sample to the 4:1 Cathode A sample, also normalized to peak intensity. As one can see, the 1:1 Cathode B material initially experiences a greater increase in intensity. However, after a few seconds, the 4:1 Cathode A sample dominates and the linear trend (result of material resistance dropping and current through the sample increasing) is faster.

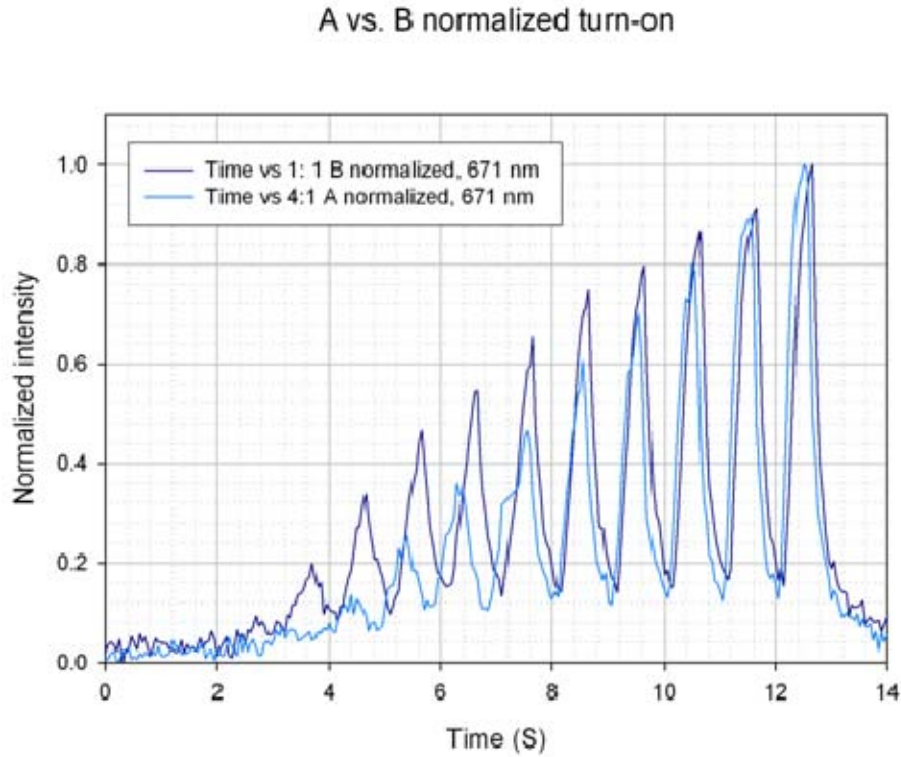

Figure 40. Intensity as a function of time during current bias pulsing for 1:1 Cathode B vs. 4:1 Cathode A

This data suggest that there are two different processes involved, and Chapter 4 will focus on the analysis of these transient behaviors.

D. THE BEST MATERIAL

At the end of this round of testing, we can conclude that the 4:1 Cathode B sample is the best material to date for use in the IIFB emitters. The only remaining question involves using the faster cathode design with the fastest material overall, pure yellow. However, the 4:1 Cathode B sample is sufficiently fast that a faster material is not necessary, and the intensity in the IR region would be lower using the yellow sample, so there is no reason to use it given the transient response we attained with the 4:1 sample.

Furthermore, after analyzing these materials one can clearly see that there is more than one process occurring during turn-on. The next chapter will focus on providing more fundamental transient measurements to provide insight into the physical mechanisms involved that lead to the change in resistance and the two distinct transient effects.

THIS PAGE INTENTIONALLY LEFT BLANK

IV. ANALYSIS OF TRANSIENT EFFECTS IN P-OLED MATERIALS

A. I-V CURVES

In every diode, there is an exponential relationship between the current and voltage, under forward bias. That is, as the applied forward bias voltage increases, the current through the diode increases exponentially according to the diode equation:

$$I = I_o (e^{\frac{V_d}{V_t}} - 1)$$

where I is the current through the diode, I_o is the saturation current, V_d is the bias voltage and V_t is the thermal energy of the diode. The thermal energy of the material conforms to the thermal energy equation:

$$V_t = \frac{kT}{q}$$

where k is Boltzmann's constant, T is the absolute temperature in Kelvin and q is the magnitude of the electron charge. The thermal energy of a material at room temperature (300 K) is approximately 25.8 meV. A plot of current vs. voltage using the diode equation produces an I-V curve for the diode.

In a normal semiconductor diode the I-V curve remains constant at a given temperature. However, the p-OLED material exhibits a “memory” behavior in the I-V curve. The curve varies depending on the warm-up to a set current; e.g., if you run a constant current through the material until the turn-on transient effects are negligible you will measure a different I-V curve than if the material were previously driven at a different current. Figure 41 shows three distinct I-V curves for the 4:1 Cathode B material warmed up to three different currents.

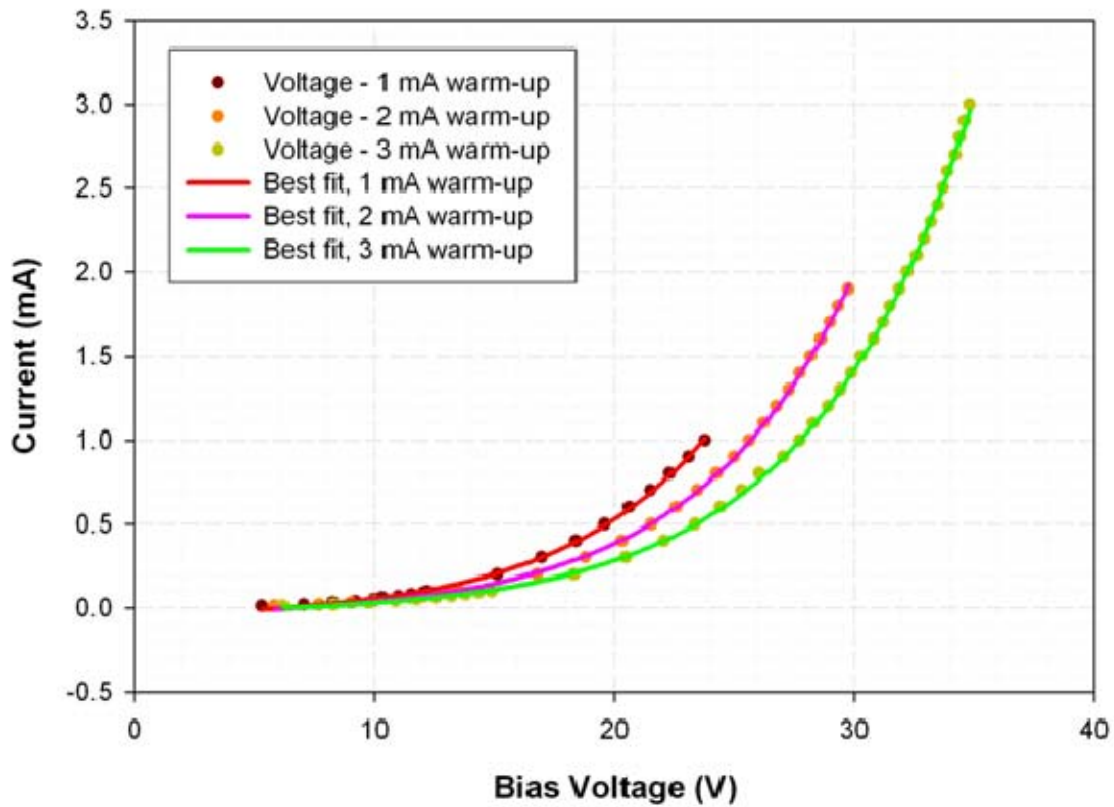

Figure 41. I-V curves for 4:1 Cathode B material

For these measurements the material was warmed using 1 mA current for five minutes, the voltage was measured and current was reduced incrementally while measuring the resulting voltage. Then the material was warmed with a 2 mA current, the measurements repeated, and then warmed to 3 mA and repeated the measurements. As one can clearly see, all three I-V curves fit a different exponential plot. For fixed voltages, the resistance of the material increases as it is warmed to a higher current.

The reason for this increase in resistance is due to the way the p-i-n junctions are formed in a p-OLED. As a bias voltage is applied across the material the conjugated polymer is electrochemically p-type doped at the anode and n-type doped at the cathode, creating a light-emitting p-n junction and an intrinsic region is created between the two [14]. In the p-OLEDs provided by Add-Vision, a larger bias voltage creates a larger

intrinsic region, increasing the resistance of the material. By initially driving the material with a higher current, a higher bias voltage is applied resulting in this expansion of the p-i-n region and increase of resistance of the material.

B. VOLTAGE VS. INTENSITY DURING THE TURN-ON PERIOD

As mentioned before, not only does the resistance increase when a higher bias voltage is applied when warming the sample to a higher current, but during the initial turn-on period of the sample the production of ions to create the p-i-n junction dramatically reduces the resistance of the sample during this warm-up period. The ion creation, leading to the forming of the p-i-n junction, is calculated by the equation:

$$Q = \int_0^{t_{JF}} I(t) dt$$

where Q is the doping charge, t_{JF} is the time required to form the p-i-n junction and $I(t)$ is the current through the material [15]. From this equation you can see the ions in the doped p and n regions increase with a higher current, allowing more light to be emitted from the recombination of electrons and holes in the junction.

Figure 42 shows a decrease in voltage of the sample while the intensity of the light produced by the emitter increases. This experiment was performed at a lower bias current (1 mA) with a higher compliance voltage (72 V) to eliminate the effects of compliance voltage during the experiment.

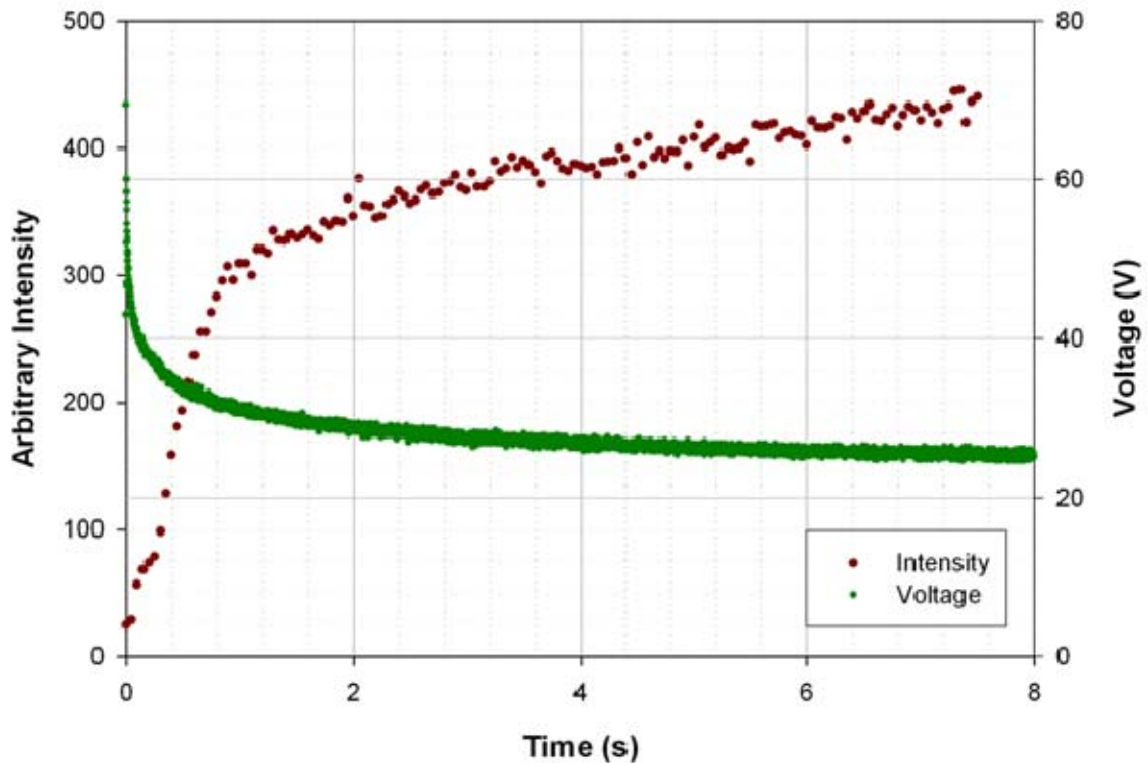

Figure 42. Peak intensity (arbitrary units) and Voltage (V) as a function of time during the turn-on of 4:1 Cathode B material

As one can see, the bias voltage drops significantly during the initial turn-on, and then reduces to the steady-state value of approximately 24 V. This decrease in voltage is a result of the p-i-n junction forming, allowing electrons and holes to recombine to produce light, and subsequently the intensity of the emitted light increases.

Once the effects of compliance voltage are eliminated one can clearly see there are two distinct processes happening during turn-on, producing two different transient effects evident in the increasing intensity of the emitted light.

C. MEASUREMENT OF TRANSIENT EFFECTS DURING TURN-ON

Figure 43 is a graph of the normalized peak intensity of the emitted light as a function of time for the 4:1 Cathode B material. The peak intensity was normalized to the maximum intensity after 5 minutes of 1 mA current.

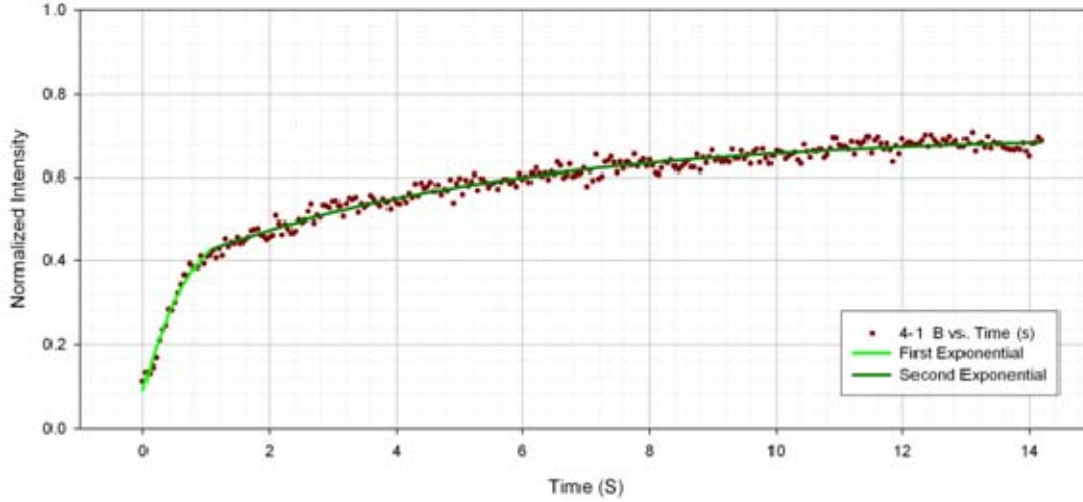

Figure 43. Peak intensity (normalized to maximum value after warm-up) vs. time (s) of the 4:1 Cathode B material

To distinguish the different transient effects, we used the Sigmaplot 9.0 fitting routine to fit a simple exponential rise to maximum plot to the section of the plot corresponding to the two different transient responses. The fitting routine analyzes the points of the plot to fit a three parameter exponential function according to the formula:

$$y = y_o + Ae^{bx}$$

As one can see, each section fits very well to a single exponential, with the intermediate period producing a sharp bend where the two exponentials meet. By combining the exponentials into a single double-exponential equation, as shown in Figure 44, the plotted equation fits very well to the entire range of values. The equation for the double exponential is

$$y = y_o + Ae^{bx} + Ce^{dx}$$

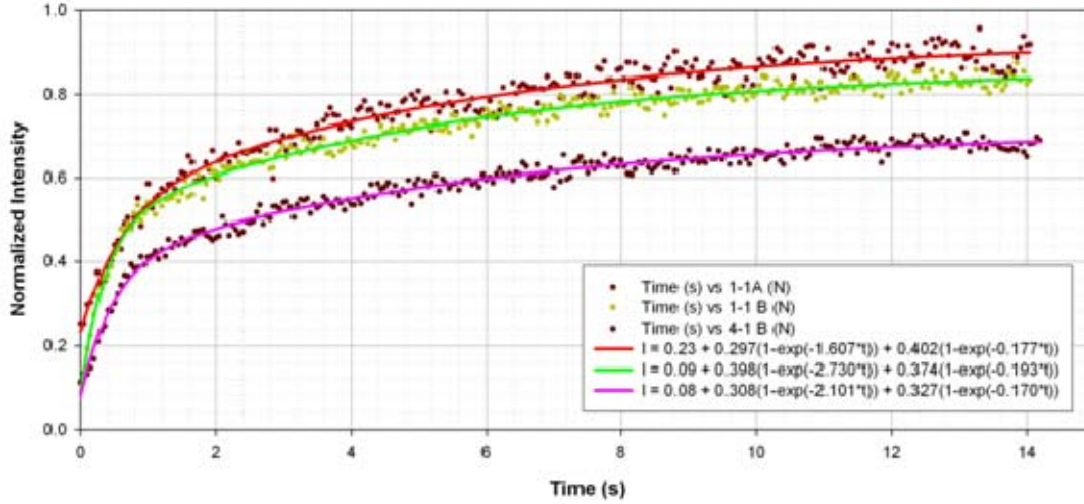

Figure 44. Peak intensity (normalized to the maximum value after warm-up) vs. time (s) of the 1:1 Cathode A, 1:1 Cathode B and 4:1 Cathode B materials.

Figure 44 shows that without the effects of compliance voltage the 4:1 Cathode B material is actually slower than the 1:1 materials during turn-on. In Chapter III I showed that the 4:1 Cathode B material had the fastest turn-on time to peak intensity and greatest overall brightness compared to the other mixtures. The difference is due to the compliance voltage imposed by the device; the resistance of the 4:1 Cathode B material reduces faster, allowing more current to pass and more ions to form, increasing the intensity of the emitter. Since the resistance is reduced much slower in the other samples, the material spends a longer amount of time pinned to compliance, not allowing the full 3 mA current to pass, resulting in a slower turn-on to full intensity when a 36 V compliance is imposed.

In order for light to emit, the p-i-n junction must form within the material. Since light is emitted and the intensity increases quickly during this initial transient it appears the first transient is a result of this junction forming. The second transient is much harder to classify and is most likely a result of how the charges are injected from the cathode into the material. Both the combination of cathode design and how the cathode and material reacts at the interface region affect how charge is injected into the material.

Further research and more complicated experiments that can better discriminate between resistance change and bias voltage compared to the intensity must be conducted to better analyze both transient regions.

THIS PAGE INTENTIONALLY LEFT BLANK

V. CONCLUSION AND REMARKS

A. NEW MATERIAL FOR THE NEXT GENERATION DEVICE

Much progress has been made in the realm of low-cost polymer-organic light emitting diodes. When this project initially started there was little interest among p-OLED manufacturers in either short turn-on times or brighter intensity in the IR region. The new materials supplied by Add-Vision show great promise in both areas, and Add-Vision will continue to provide brighter and faster samples for use in future generations of the IIFF system.

The best material to date for use in the IIFF system is the 4:1 (Y:R) mixture using the new cathode design (Cathode B.) This material has a 410% increase in brightness in the IR region when compared to the original Covion yellow sample. It also has a near instantaneous turn-on when tested for use in the IIFF device application. The material provides 80% of maximum intensity within the first pulse and over 95% of maximum intensity in the second pulse, making a “warm-up” activation during device turn-on unnecessary.

B. INITIAL MEASUREMENTS OF TRANSIENT PHENOMENA

The new samples provided by Add-Vision showed that both overall brightness and turn-on time of the material are affected by material composition and cathode design. Although we have determined the best material for use in the IIFF device and determined that the new cathode design improves performance, it is still unclear how the material composition changes the brightness and turn-on time. We concluded that there is a double exponential relationship between intensity and turn-on time. The first transient in the double exponential function corresponds to the creation of the p-i-n junction within the material, however, although we believe the second transient is a function of the charge injection into the material, it is still unclear whether it is a function of the cathode design, the interface where the cathode and material join or both.

C. FURTHER RESEARCH

Although the 4:1 Cathode B material has been identified as suitable material for use in the IIFF design Add-Vision continues to improve its product and is currently developing new ink formulations that will provide a higher concentration of spectral response in the IR region. Research needs to be conducted on overall brightness in the IR region, turn-on time and how they both compare to the current best sample.

Furthermore, although we have shown the existence of the double exponential response in the turn-on of the sample and have identified some of the physical mechanisms responsible for this behavior, more research needs to be conducted to completely identify the many mechanisms present in these materials.

LIST OF REFERENCES

- [1] Mickey McCarter. "Identification Friend or Foe," *Special Operations Technology*, Vol. 2, Issue 6, September 13, 2004, retrieved November 21, 2008, <http://www.special-operations-technology.com/article.cfm?DocID=610>.
- [2] Johannah Schumacher. "Time dependant behavior of Light Emitting Polymers for potential Individual Identify Friend or Foe (IIFF) Applications," Naval postgraduate School, December 2007.
- [3] "Phoenix Light" from Global Security website, retrieved November 21, 2008, <http://www.globalsecurity.org/military/systems/ground/phoenix-light.html>.
- [4] Matthew Kalman. "Hezbollah night-vision gear was from Britain, Israel says," San Francisco Chronicle, August 20, 2006, retrieved November 21, 2008, <http://www.sfgate.com/cgi-bin/article.cgi?f=/c/a/2006/08/20/MNGK9KLVH41.DTL&hw=hezbollah+night+vision&sn=002&sc=917>.
- [5] Unites States Marine Corps night vision devices training manual, provided by Major Brian Forney.
- [6] John G. Victor, Matthew C. Wilkinson and Susan A. Carter. "Screen printing light-emitting polymer patterned devices," *U.S. Patent* No. 6,605,483, August 12, 2003
- [7] Alan J. Heeger. "Semiconducting and metallic polymers," Nobel Lecure, December 8, 2000, retrieved November 21, 2008, http://nobelprize.org/nobel_prizes/chemistry/laureates/2000/heeger-lecture.pdf.
- [8] Alan J. Heeger, Autobiography, *Les Prix Nobel/Nobel Lectures*, 2001, retrieved November 21, 2008, http://nobelprize.org/nobel_prizes/chemistry/laureates/2000/heeger-autobio.html.
- [9] Schematic diagrams of light emitting diodes, Wikipedia Commons, 2008, retrieved November 21, 2008, <http://en.wikipedia.org/wiki/File:PnJunction-LED-E.PNG>.
- [10] Susan A. Carter and John G. Victor. "Screen printable electrode for light emitting polymer device," *U.S. Patent Application* 20030153141, August 14, 2003.
- [11] Patrick S. Williams. "Triggered infrared emitter displays for Individual Identify Friend-or-Foe (IIFF) and Vehicular Mounted Identify Friend-or-Foe (VMIFF) devices," *Naval Postgraduate School*, June 2007.

- [12] Ed Caram and Joe Contreras. "Danger in uniform," Newsweek, July 5, 2007, retrieved November 21, 2008, <http://www.newsweek.com/id/33243>.
- [13] Junfeng Fang, et.al., "Understanding the operation of light emitting electrochemical cells," *Applied Physics Letters*, August 12, 2008.

INITIAL DISTRIBUTION LIST

1. Defense Technical Information Center
Ft. Belvoir, Virginia
2. Dudley Knox Library
Naval Postgraduate School
Monterey, California
3. Professor James H. Luscombe
Naval Postgraduate School
Monterey, California
4. Professor James H. Luscombe
Naval Postgraduate School
Monterey, California
5. Professor Nancy M. Haegel
Naval Postgraduate School
Monterey, California
6. Professor Peter P. Crooker
Naval Postgraduate School
Monterey, California
7. Lieutenant James M. Elmore
Naval Postgraduate School
Monterey, California
8. Dr. Devin McKenzie
Director of Technology
Add-Vision, Inc.
Scott's Valley, California