



**AFRL-RH-WP-TR-2009-0004**

**Operational Effects Assessment Visualization Tool  
(OEAVT)**

**Christopher R. Hale**

**Richard Loreaux**

**Harry H. Heaton**

**Roger Overdorf**

**Robert S. McClure**

**Science Applications International Corporation**

**4031 Colonel Glenn Hwy**

**Beavercreek OH 45431**

**December 2008**

**Final Report for July 2004 to December 2008**

Approved for Public Release; Distribution  
is unlimited.

**Air Force Research Laboratory  
711th Human Performance Wing  
Human Effectiveness Directorate  
Warfighter Interface Division  
Collaborative Interfaces Branch  
Wright-Patterson AFB OH 45433**

## **NOTICE AND SIGNATURE PAGE**

Using Government drawings, specifications, or other data included in this document for any purpose other than Government procurement does not in any way obligate the U.S. Government. The fact that the Government formulated or supplied the drawings, specifications, or other data does not license the holder or any other person or corporation; or convey any rights or permission to manufacture, use, or sell any patented invention that may relate to them.

This report was cleared for public release by the 88th Air Base Wing Public Affairs Office and is available to the general public, including foreign nationals. Copies may be obtained from the Defense Technical Information Center (DTIC) (<http://www.dtic.mil>).

### **TECHNICAL REVIEW AND APPROVAL**

**AFRL-RH-WP-TR-2009-0004**

**THIS TECHNICAL REPORT HAS BEEN REVIEWED AND IS APPROVED FOR  
PUBLICATION.**

#### **FOR THE DIRECTOR**

**//signed//**

Donald L. Monk  
Program Manager  
Collaborative Interfaces Branch

**//signed//**

Daniel G. Goddard  
Chief, Warfighter Interface Division  
Human Effectiveness Directorate  
711th Human Performance Wing

This report is published in the interest of scientific and technical information exchange, and its publication does not constitute the Government's approval or disapproval of its ideas or findings.

# REPORT DOCUMENTATION PAGE

*Form Approved*  
**OMB No. 0704-0188**

Public reporting burden for this collection of information is estimated to average 1 hour per response, including the time for reviewing instructions, searching data sources, gathering and maintaining the data needed, and completing and reviewing the collection of information. Send comments regarding this burden estimate or any other aspect of this collection of information, including suggestions for reducing this burden to Washington Headquarters Service, Directorate for Information Operations and Reports, 1215 Jefferson Davis Highway, Suite 1204, Arlington, VA 22202-4302, and to the Office of Management and Budget, Paperwork Reduction Project (0704-0188) Washington, DC 20503.

**PLEASE DO NOT RETURN YOUR FORM TO THE ABOVE ADDRESS.**

<b>1. REPORT DATE</b> ( <i>DD-MM-YYYY</i> ) 19-12-2008		<b>2. REPORT TYPE</b> Final		<b>3. DATES COVERED</b> ( <i>From - To</i> ) July 2004 – December 2008	
<b>4. TITLE AND SUBTITLE</b> Operational Effects Assessment Visualization Tool (OEAVT)				<b>5a. CONTRACT NUMBER</b> FA8650-04-C-6475	
				<b>5b. GRANT NUMBER</b>	
				<b>5c. PROGRAM ELEMENT NUMBER</b> 63231F	
<b>6. AUTHOR(S)</b> Christopher R. Hale Richard Loreaux Harry H. Heaton Roger Overdorf Robert S. McClure				<b>5d. PROJECT NUMBER</b> 2830	
				<b>5e. TASK NUMBER</b> 30	
				<b>5f. WORK UNIT NUMBER</b> 28303011	
<b>7. PERFORMING ORGANIZATION NAME(S) AND ADDRESS(ES)</b> Science Applications International Corporation 4031 Colonel Glenn Hwy Beavercreek OH 45431				<b>8. PERFORMING ORGANIZATION REPORT NUMBER</b>	
<b>9. SPONSORING/MONITORING AGENCY NAME(S) AND ADDRESS(ES)</b> Air Force Materiel Command Air Force Research Laboratory 711th Human Performance Wing Human Effectiveness Directorate Warfighter Interface Division Collaborative Interfaces Branch Wright Patterson AFB OH 45433-7022				<b>10. SPONSOR/MONITOR'S ACRONYM(S)</b> 711 HPW/RHCP	
				<b>11. SPONSORING/MONITORING AGENCY REPORT NUMBER</b> AFRL-RH-WP-TR-2009-0004	
<b>12. DISTRIBUTION AVAILABILITY STATEMENT</b> Approved for Public Release; Distribution is unlimited.					
<b>13. SUPPLEMENTARY NOTES</b> 88ABW/PA Cleared 01/13/09, 88ABW-09-0061.					
<b>14. ABSTRACT</b> The goal of the OEAVT program was to create innovative, decision-actionable work support systems that would enable the AOC Operational Assessment Team to plan and carry out assessment of effects-based plans within a dynamically evolving air campaign. This would be accomplished by providing intuitive, high-level visualizations of mission effects, mechanisms and their interrelationships during the air operations planning and assessment phases of successive ATO cycles. SAIC's technical approach to developing OEAVT was guided by a desire to achieve three major objectives. These were to (1) thoroughly understand the requisite OA knowledge, skills, and experience that would enable design and development of an innovative, effective OA support system; (2) apply proven, reliable engineering processes that would ensure effective development of the OEAVT; and (3) implement an evaluation methodology that would expose OEAVT to a Test Readiness Level 6 environment, in order to demonstrate its operational effectiveness and create opportunities for transition to the operational setting.					
<b>15. SUBJECT TERMS</b> Operational Assessment, Effects Based Operations, Assessment Visualization					
<b>16. SECURITY CLASSIFICATION OF:</b> Unclassified			<b>17. LIMITATION OF ABSTRACT</b>	<b>18. NUMBER OF PAGES</b>	<b>19a. NAME OF RESPONSIBLE PERSON</b>
a. REPORT U	b. ABSTRACT U	c. THIS PAGE U	SAR	277	Donald Monk
					<b>19b. TELEPHONE NUMBER</b> ( <i>Include area code</i> )

This page blank intentionally.

# Table of Contents

<b>1. INTRODUCTION.....</b>	<b>1</b>
<b>2. PURPOSE OF THE OEAVT PROGRAM.....</b>	<b>3</b>
2.1 TASK 1: TRANSLATE COGNITIVE TASK ANALYSIS (CTA) INTO SYSTEM ENGINEERING REQUIREMENTS.....	3
2.1.1 Conduct Cognitive Systems Analysis (CSA) of Operational Assessment teams.....	3
2.1.2 Validate CSA results.....	3
2.1.3 Compile CSA Results into a System Engineering Tool/Database.....	4
2.2 TASK 2: EVALUATE OEAVT CANDIDATE SOLUTIONS.....	4
2.3 TASK 3: DEVELOP OEAVT SOLUTIONS.....	4
2.4 TASK 4: CONDUCT OPERATIONAL TEST.....	5
2.5 TASK 5: REPORT RESULTS.....	5
<b>3. DOCUMENT OVERVIEW.....</b>	<b>6</b>
<b>4. OPERATIONAL DIFFERENCES BETWEEN TACTICAL ASSESSMENT AND OPERATIONAL ASSESSMENT.....</b>	<b>7</b>
4.1 BEHAVIORAL AND COGNITIVE DIFFERENCES BETWEEN TA AND OA.....	9
4.1.1 Purpose of analysis.....	9
4.1.2 Objects of analysis.....	10
4.1.3 Workflow characteristics.....	10
4.1.4 Types of decisions and decision processes.....	11
4.1.5 Criteria for success.....	11
<b>5. STRUCTURE OF THE OEAVT DEVELOPMENT TEAM.....</b>	<b>13</b>
5.1 SUBCONTRACTORS.....	13
<b>6. OEAVT PROGRAM CHALLENGES.....</b>	<b>14</b>
<b>7. DESCRIPTION OF COGNITIVE SYSTEMS ENGINEERING METHODOLOGY UNDERLYING OEAVT DEVELOPMENT.....</b>	<b>16</b>
7.1 DOMAIN ANALYSIS AND DERIVATION OF PERCEPTUAL/COGNITIVE REQUIREMENTS.....	16
7.2 MAP CSE RESULTS TO SYSTEM ENGINEERING REQUIREMENTS ANALYSIS ACTIVITIES AND PRODUCTS.....	17
7.3 DEVELOP A SYSTEM MODEL.....	19
7.4 DERIVE SYSTEM REQUIREMENTS.....	19
7.5 MAP REQUIREMENTS TO PERCEPTUAL/COGNITIVE WORK ELEMENTS.....	19
7.6 VISUALIZATION DESIGN.....	20
<b>8. OEAVT OA COGNITIVE AND WORK ANALYSIS.....</b>	<b>21</b>
<b>9. OEAVT SYSTEM ENGINEERING.....</b>	<b>26</b>
9.1 STEP 1: PERFORM OEAVT CONCEPT MAP ANALYSIS.....	27
9.2 STEP 2: DEVELOP FUNCTIONAL SYSTEM REPRESENTATION AND ANALYSIS.....	28
9.3 STEP 3: SME REVIEW OF FUNCTIONAL REPRESENTATION.....	30
9.4 STEP 4: MAP FUNCTIONAL AND COGNITIVE REQUIREMENTS.....	30
9.5 STEP 5: SCOPE REQUIREMENTS.....	32
<b>10. OEAVT SOFTWARE ARCHITECTURE.....</b>	<b>34</b>
10.1 SOFTWARE ENGINEERING OVERVIEW.....	34
10.2 SOFTWARE COMPONENTS.....	35
10.3 SCVOA APPLICATION.....	36
10.3.1 <b>Demonstration Mode.</b> .....	37
10.3.2 <b>Demonstration Data.</b> .....	37

10.3.3	<b>Plan Hierarchy Visualization</b> .....	37
10.3.4	<b>Assessment Visualizations</b> .....	38
10.3.5	<b>Value Model</b> .....	38
<b>11.</b>	<b>OEAVT SYSTEM COMPONENTS</b> .....	<b>42</b>
<b>11.1</b>	<b>Action–Effect Contrast Visualization</b> .....	<b>42</b>
11.1.1	Purpose .....	42
11.1.2	Development Process.....	43
11.1.3	Current Status and Capability .....	44
<b>11.2</b>	<b>Geo-spatial Effects Visualization (GEV)</b> .....	<b>53</b>
11.2.1	Purpose .....	53
11.2.2	GEV Development.....	53
11.2.3	Current Status and Future Development .....	56
<b>11.3</b>	<b>TBONE-IWPC Indicator Interface (TI3)</b> .....	<b>56</b>
11.3.1	Purpose .....	56
11.3.2	Development.....	57
11.3.3	Current Status .....	60
<b>11.4</b>	<b>Global Effects Matrix-Synchronization (GEM-S) IO Assessment Visualization Design and Prototype</b> .....	<b>62</b>
11.4.1	Purpose .....	62
11.4.2	GEM-S Assessment Development.....	63
11.4.3	Current Status and Future Development .....	65
<b>12.</b>	<b>REFERENCED DOCUMENTS</b> .....	<b>73</b>
<b>13.</b>	<b>ACRONYMS AND ABBREVIATIONS</b> .....	<b>74</b>
<b>APPENDIX A</b>	<b>OEAVT CONCEPT MAPS AND CRITICAL DECISION SPREADSHEETS</b> .....	<b>A-1</b>
<b>APPENDIX B</b>	<b>OEAVT SYSTEM MODEL (CORE EFFBDS)</b> .....	<b>B-1</b>
<b>APPENDIX C</b>	<b>OEAVT SYSTEM REQUIREMENTS</b> .....	<b>C-1</b>
<b>APPENDIX D</b>	<b>GEO-SPATIAL EFFECTS VISUALIZATION (GEV)</b> .....	<b>D-1</b>
<b>APPENDIX E</b>	<b>GEM-S IO ASSESSMENT PROTOTYPE VISUAL SPECIFICATION</b> .....	<b>E-1</b>

## List of Figures

FIGURE 1: THE TARGETS AND ASSESSMENT TEAMS (TAT) COLLECTS, FUSES, SYNTHESIZES, REPORTS, AND FORMULATES RECOMMENDATIONS ON TACTICAL TASKS (TT) .....	7
FIGURE 2: EFFECTS-CHAIN CONSTRUCTS EMPLOYED BY TTLE TO DELIVER DISCRETE TTOS.....	8
FIGURE 3: CSE TO SYSTEM ENGINEERING REQUIREMENTS MAPPING .....	18
FIGURE 4: ONTOLOGICAL CATEGORIES USED IN THE OEAVT CSE ANALYSIS .....	22
FIGURE 5: SYSTEM ANALYSIS PROCESS.....	26
FIGURE 6: CORE DATABASE.....	27
FIGURE 7: TOP LEVEL OPERATIONAL ASSESSMENT TASK DIAGRAM .....	28
FIGURE 8: DECOMPOSITION OF THE “EXECUTION” OPERATIONAL TASK .....	29
FIGURE 9: “ANALYZE OPERATIONAL RESULTS” DECOMPOSITION.....	29
FIGURE 10: CORE EXAMPLE OF A FUNCTION AND THE ASSOCIATED ORIGINATING REQUIREMENTS .....	31
FIGURE 11: EXAMPLE OF TWO OEAVT REQUIREMENTS .....	32
FIGURE 12: SCVOA PACKAGE OVERVIEW.....	36
FIGURE 13: GREATHOUSE TRUTH TABLE .....	38
FIGURE 14: VALUE MODEL ROLL-UP .....	40
FIGURE 15: THE AECV SUPPORTS ASSESSMENT THROUGH THE USE OF THREE PANES .....	45
FIGURE 16: AECV SUMMARY VIEW .....	45
FIGURE 17: AECV TREND VIEW .....	46
FIGURE 18: INDICATOR CONFIDENCE VALUES ARE SHOWN AS CODED BLOCKS UNDER INDICATOR TEXT .....	48
FIGURE 19: PANEL USED TO EDIT INDICATORS AND WEIGHTS .....	49
FIGURE 20: CONFIDENCE ZONE EDITOR .....	49
FIGURE 21: INDICATOR DATA SOURCES .....	50
FIGURE 22: PLAN ELEMENT VALUE STATUS .....	50
FIGURE 23: HIERARCHICAL SEARCH THROUGH PLAN ELEMENTS .....	51
FIGURE 24: GEV PHOTOSHOP MOCKUP.....	54
FIGURE 25: GEV GUI CONCEPT.....	55
FIGURE 26: GEV SCHEMATIC DESIGN MOCKUP RENDERED IN OPENMAP .....	56
FIGURE 27: TI3 MODIFICATION TO eCAT GUI .....	58
FIGURE 28: TBONE ASSESSMENT DATA CHAIN .....	59
FIGURE 29: TI3 CONOPS .....	59
FIGURE 30: TI3 INDICATOR ASSESSMENT INITIAL SCREEN .....	60
FIGURE 31: TI3 KEYWORD SEARCH FORMAT.....	61
FIGURE 32: TI3 BROWSE FORMAT.....	62
FIGURE 33: UNCLASSIFIED SURROGATE FOR THE GEM-S “HORSE BLANKET”.....	63
FIGURE 34: INITIAL IFO ASSESSMENT CONCEPT GRAPHIC PRESENTED TO JIOWC.....	64
FIGURE 35: BASIC IFO ASSESSMENT DISPLAY, WITH A DIRECTION/MAGNITUDE GRID.....	65
FIGURE 36: ACTIVE IO ASSESSMENT DISPLAY, WITH A DURATION/DEGREE CAPACITY REDUCTION GRAPH .....	66
FIGURE 37: INDICATOR HISTORY CONCEPT .....	69
FIGURE 38: MULTIPLE COLLATERAL EFFECTS CONCEPT FOR ACTIVE IO.....	70

## List of Tables

TABLE 1: SUMMARY COMPARISON OF TA AND OA .....	12
TABLE 2: COGNITIVE WORKFLOW ELEMENTS (CWE) IDENTIFIED FROM THE CSE ARTIFACTS .....	25

This page blank intentionally.

# 1. Introduction

Effects-Based Operations (EBO) provides a new paradigm for conceiving and conducting military campaigns. Supplement One to the Commander's Handbook for an Effects Based Approach to Joint Operations (13 March 2006) defines EBO as, "Operations that are planned, executed, assessed, and adapted based on a holistic understanding of the operational environment in order to influence or change system behavior or capabilities using the integrated application of select instruments of power to achieve directed policy aims." The handbook also points out that EBO is comprised of a continuous loop of three basic processes: planning, execution and assessment. The focus of this effort is on the final leg of the EBO triangle, assessment.

Within the air component of the joint forces structure, the Strategy Plans Team (SPT) of the Strategy Division has the responsibility for translating the Joint Forces Commander's (JFC) desired effects into a strategy of operational objectives, tactical objectives, and tactical tasks. Air strategy objectives and tasks are developed through a Course of Action (COA) analysis where alternative approaches are specified and where the strengths and weaknesses of each are compared to determine which is superior.

EBO is a performance-based process with measurable goals. The SPT specifies Measures of Effectiveness (MoE) to assess progress toward goals. The Operational Assessment Team (OAT) develops and implements a plan that gathers data on indicators and other factors defined by planners to generate the performance metrics. Thus, the OAT implements the feedback loop that allows the SPT to evaluate how their plan is progressing and make adjustments where necessary. Current strategy planning and assessment processes are mostly manual. This is due, in part, to the complex, somewhat fuzzy nature of the strategy processes. An important role of the Operational Effect Assessment Visualization Tool (OEAVT) envisioned by the original Program Research and Development Announcements (PRDA) was to help formalize the processes, data, and assessments used by the Strategy Division by providing a top level visualization of the battle space.

While there are a variety of problems the strategy visualization tools must solve, a problem common to both the SPT and OAT is that they currently are "disconnected" from the Air and Space Operations Center (AOC) data environment (e.g., the Theater Battle Management Core System and other key systems). By disconnected, we mean that strategy planning products, which contain the MoEs, are not entered into the AOC data environment. Also, by having no visibility into the AOC data environment, the OAT is prevented from establishing automated collection of the air campaign results required to make assessments.

One result of this lack of access is an inability to link a given Air Tasking Order (ATO) to the broader effects-based plan. This loss of operational context results in "open-loop" air campaigns, in which plans cannot be adapted to the evolution of operations. Thus, AOC Combat Operations Division personnel have access to the ATO but they do not have access to information about a particular target's importance to the broader campaign strategy desired effects or to the status of that target with respect to the goals of the JFACC and JFC. Thus, it is possible to adversely affect implementation of the plan by re-tasking strike assets to lower valued targets.

A second significant impact is that it is difficult for the OAT to assess how well effects are being achieved because (1) they lack insight into how effects are implemented through a given ATO and (2) the AOC data environment does not have the capability to record and organize execution data, strike results and non-kinetic activities in a form readily interpretable by the assessment team. Essentially, this means that the feedback loop, which makes EBO possible, is broken in the AOC.

## **2. Purpose of the OEAVT Program**

The goal of the OEAVT program was to create innovative, decision-actionable work support systems that would enable the AOC OAT to plan and carry out assessment of effects-based plans within a dynamically evolving air campaign. This would be accomplished by providing intuitive, high-level visualizations of mission effects, mechanisms and their interrelationships during the air operations planning and assessment phases of successive ATO cycles.

SAIC's technical approach to developing OEAVT was guided by a desire to achieve three major objectives. These were to (1) thoroughly understand the requisite OA knowledge, skills, and experience that would enable design and development of an innovative, effective OA support system; (2) apply proven, reliable engineering processes that would ensure effective development of the OEAVT; and (3) implement an evaluation methodology that would expose OEAVT to a Test Readiness Level 6 environment, so as to demonstrate its operational effectiveness and create opportunities for transition to the operational setting. The baseline plan for achieving these three objectives consisted of five technical tasks:

### **2.1 Task 1: Translate Cognitive Task Analysis (CTA) into System Engineering Requirements.**

#### **2.1.1 Conduct Cognitive Systems Analysis (CSA) of Operational Assessment teams.**

Task 1 focused on gathering operational, behavioral and work information needed to understand the Operational Assessment domain, the tasks involved in carrying out assessment and the opportunities, strategies and constraints involved in planning for and implementing an assessment program for particular air campaigns. The CSA included analyses of OA work domains; analyses of assessor tasks and strategies; and analyses of the socio-technical and organizational factors important in the conduct of operational assessment. An additional goal of the effort was identification of critical measures of performance (i.e., key performance factors) that could be used as metrics for OAT tools and operational effectiveness.

#### **2.1.2 Validate CSA results.**

The CSA results obtained were validated prior to the initiation of system development. Validation was accomplished by subjecting the results to review by Air Force uniformed and/or civilian personnel who were Subject Matter Experts (SME) in Strategy Division operations. Results obtained in the validation process were used to update and/or correct results of the analysis conducted.

### 2.1.3 Compile CSA Results into a System Engineering Tool/Database

This task was to ensure that CSA results were included in OEAVT system requirements. This was required for effective development of visualization support for the OA domain. We relied on both our own process and complimentary system engineering tools to accomplish this objective. Our review of available system and software engineering tools revealed that the CORE®<sup>1</sup> tool was the most suitable for incorporating and transforming the results of a CSA into system engineering content suitable for requirements development.

## 2.2 Task 2: Evaluate OEAVT Candidate Solutions

The requirement for Task 2 as laid out in the Statement of Work, (SOW), states that SAIC is to use the system engineering requirements derived from the CTA developed in Task 1, to accomplish an analysis to determine solution categories. Based on these solution categories, SAIC is to develop and create prototype display and database design concepts and analytically evaluate each to determine viability.

Our approach to evaluating candidate solution categories is an explicit merger of cognitive, human factors, and system and software engineering processes. This merger ensures that insights into OEAVT user needs derived from the CTA are converted into sound visualization and other concepts. One of the main systems of records at the time was Information Warfare Planning Capability (IWPC). This system was investigated as a starting point. Review of the previous work done by ManTech was also accomplished. It was decided that a significant conceptual and technological gap existed in the current AOC tools from what the output of the CTA indicated was needed. We decided to design our own set of User interfaces extensive prototyping prior to development. These prototypes were manipulated and critiqued by prospective users and our own OA SMEs.

## 2.3 Task 3: Develop OEAVT Solutions

This task involved developing the OEAVT software system components. Capability Maturity Model® Integration (CMMI<sup>SM</sup>) Level 3 processes were applied to development of the system. Software requirements were generated from the System Requirements and a software architectural design then followed. The software components were developed using Java<sup>TM2</sup> and the individual units were tested to verify functionality. This task also included the integration of software components that make up the OEAVT system. See Section 12 for more detail on the development of the OEAVT System.

---

1 CORE is a registered trademark of Vitech Corporation, 2070 Chain Bridge Road Suite 100 Vienna, Virginia 22182

2 Java is a trademark of Sun Microsystems Inc.

## **2.4 Task 4: Conduct Operational Test**

The SOW requirement for this Task was for the OEAVT system software to operate successfully at an operational test. The SOW states, that the OEAVT software system, completed as part of the spiral development process, shall be integrated with the Task 3 database and evaluated within an operational context using a scenario-specific database. Successful completion of the operational test shall result in a Technology Readiness Level (TRL) 6 system. At TRL 6, a representative model or prototype system would be tested in a relevant environment. The demonstration might represent an actual system application, or it might only be similar to the planned application, but use the same technologies.

To satisfy this SOW requirement, SAIC conducted the operational testing at the Warfighter Analysis of Innovative Technologies and Concepts (WAIT & C) event at Langley, AFB. Members of the SAIC team attended this event as part of an ongoing series of technology demonstrations carried out by the GCIC. Focus of this event was on operational planning and assessment. Eight SMEs were invited to the event to serve as evaluators of the technologies under demonstration. The OEAVT system was successfully demonstrated for each SME. Opportunities for improvement were recorded and then prioritized and weighted against our current solution and available funding. A decision was then made as to whether the improvement could be incorporated into the OEAVT development. Operational SMEs provided an excellent opportunity to showcase OEAVT's new Operational Assessment capabilities.

## **2.5 Task 5: Report Results**

The output of Task 5 is a final technical report documenting results of the OEAVT system development effort, as well as the engineering methods used to produce the system. This final report also includes a copy of the data used to document results in a format readily usable by future Operational Assessment team's visualization tool developers.

### 3. Document Overview

In the remainder of this document we report on the development of OEAVT and present the system that has resulted from that development effort. We begin with a discussion of the differences between Tactical Assessment (TA) and Operational Assessment (OA) in Section 5. This sets the context for the analyses, engineering and development discussions that follow. This description of differences is followed by a discussion of the OEAVT team in Section 6, including members from the prime contractor and each sub-contractor. This will allow us to describe the roles played by each team member in the development of the system.

We then follow in Section 7 with a brief discussion of some of the challenges that we encountered during the evolution of OEAVT. This was a complex program, as open systems typically are, with many “moving parts.”

Section 8 outlines the general manner in which the OEAVT team developed the system. Development was based on an integrated joint cognitive system methodology that has been used successfully in a number of system engineering efforts by members of the SAIC team. Section 9 of the report describes the cognitive and work analyses carried out in the initial stages of OEAVT development.

A detailed description of OEAVT system engineering follows in Section 10. The software architecture of the system is presented in Section 11. The final discussion of the report, Section 12, includes descriptions of the system components that resulted from the OEAVT engineering and development processes. These include the Theater Battle Operations Net-centric Environment-Information Warfare Planning Capability (TBONE-IWPC) Indicator Interface (TI3) module, the Action-Effects Contrast Visualization (AECV) module, the Geo-spatial Effects Visualization (GEV) module and the Global Effects Matrix-Synchronization (GEM-S) module. The report concludes with Appendices containing detailed descriptions of the analysis and engineering products of the program.

#### 4. Operational Differences Between Tactical Assessment and Operational Assessment

The distinction between combat or tactical assessment (TA) and Operational Assessment (OA) is often blurred, even by practicing USAF assessors. The cognitive and behavior aspects of TA and OA were both examined over the course of this effort to better understand and define these aspects of assessment.

Operational assessment is the highest level of assessment at the Joint Forces Air Component Commander (JFACC) level. It provides plan status and recommendations to both JFACC and Combined Forces Commander (CFC). Personnel include operations research analysts, pilots, navigators, information operators, intelligence analysts, etc. They are assigned to the Operational Assessment Team (OAT) in the Strategy Division. Their assessments derive from a combination of intelligence, operations, and logistics sources. According to the *Air Force EBO Lexicon*, OA is the “*Joint force components’ evaluation of the achievement of their objectives, both tactical and operational, through assessment of effects, operational execution, environmental influences, and attainment of the objectives’ success indicators, in order to develop strategy recommendations.*”

In particular, OA focuses on higher-order elements of a plan, defined in terms of logical sequences of causes and effects. Based on Air Force Tactics, Techniques, and Procedures (AFTTP) *Air and Space Strategy*, an operational line of effect (OLE) is defined as “*a logical line that defines, in sequence and purpose, the orientation of operational-level actions and associated causal links and effects, tactical lines of effect and their associated tactical objectives and any additional causal links in the delivery of an operational objective.*” This relationship is shown in Figure 1.

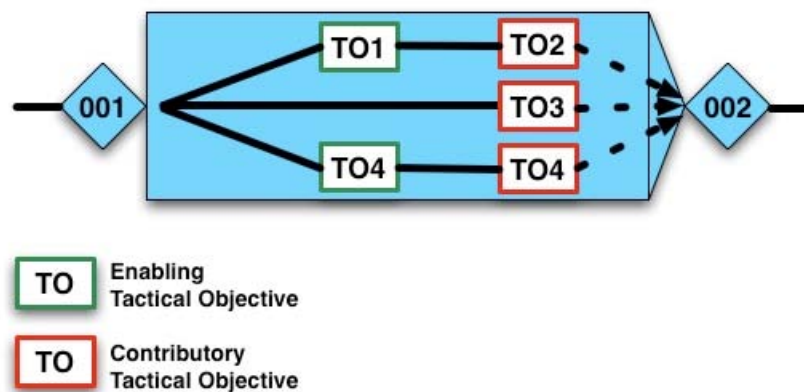

**Figure 1: The Targets and Assessment Teams (TAT) Collects, Fuses, Synthesizes, Reports, and Formulates Recommendations on Tactical Tasks (TT)**

OA relies on Tactical Assessment to gauge progress toward achieving Operational Objectives (OOs). It measures the status of Tactical Tasks and Tactical Objectives (TOs) to arrive at the status of OOs. Operational assessors must always be mindful, however, of the reason for their assessment of OOs. Their fused results are intended to be applied to the status of campaign effects, including end-state conditions. The latter should be the central focus in all cases, to determine the overall campaign status, how we are supporting it, and when we can decrease and halt operations.

TA is the lowest level of assessment at the Joint Forces Air Component Commander (JFACC) level. It provides target/plan status and recommendations to the OA Team. TA occurs in the Tactical Assessment Cell (TAC), which is part of the Targets and Assessment Team (TAT) in the ISR Division. Personnel primarily consist of intelligence analysts and targeteers. Their information is almost exclusively derived from intelligence sources. Based on the *Air Force EBO Lexicon*, TA is the “overall determination of the success of tactical operations.”

TA focuses on actions carried out in support of tactical tasks, and direct and second-order effects of those actions on planned targets. Based on Air Force Tactics, Techniques, and Procedures (AFTTP) Air and Space Strategy, a Tactical Line of Effect (TLE) is the element of the Effects-Based Operational Design (EBOD) construct that captures and details the operational design for the delivery of a TO along a particular OLE. A TLE is defined as “a logical line that defines, in sequence and purpose, the orientation of tactical task lines of effect, their associated intended tactical task objectives (TTOs), and any additional causal links in the delivery of a tactical objective.”

In the same manner that the TLE is the scheme of effects (i.e., TTOs) that will deliver a TO, a Tactical Task Line of Effect (TTLE) is the “logical line that defines, in sequence and purpose, the orientation of tactical actions, consequential direct and indirect effects and associated causal linkages in the delivery of an intended tactical task objective.” TTLEs will normally employ one of three basic effects-chain constructs that will detail the plan for delivering an intended discrete TTO. This sequence is shown in Figure 2.

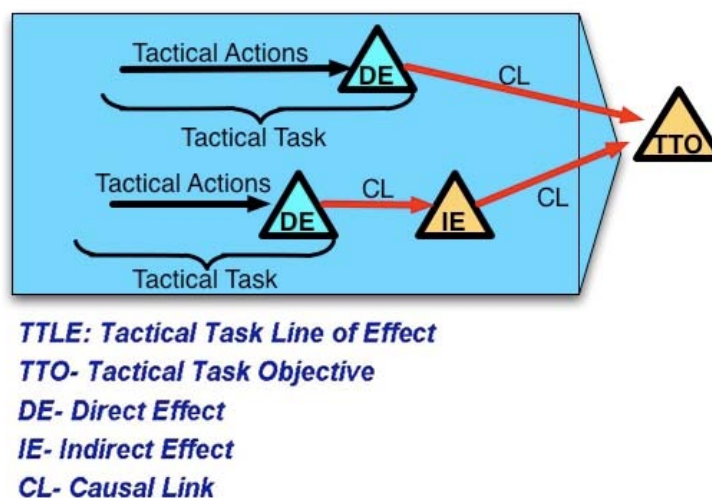

**Figure 2: Effects-chain Constructs Employed by TTLE to Deliver Discrete TTOs**

The boundary layer between TA and OA also is worth noting. On the one hand, TA is taken as all the plan elements and attributes up to, but excluding the Tactical Objective (TO), while on the other, it may include the TO level as well. Regardless of the delineation, specific guidance must be given to all assessors involved, with consideration given for resource availability, capability, and product delivery.

TA feeds OA by means of “rolling up” tactical-action, as well as effect status. Tactical assessors gauge the progress of Tactical Tasks (TTs) by monitoring changes in target status. This is done through collection, fusion, and synthesis of tactical evidence. Reporting, accompanied by recommendations, is then made to the OAT. However, this is by no means the sole basis of OA. Rather independent evidence must be analyzed at each level, with assessments based on a broad spectrum of inputs.

#### **4.1 Behavioral and Cognitive Differences Between TA and OA**

In addition to the operational differences between tactical and Operational Assessment discussed above, there are several cognitive and behavioral differences as well. These differences fall into five categories: Purpose of analysis; objects of analysis; workflow characteristics; types of decisions made in each type of assessment and the processes used to reach decisions; and the criteria for success.

##### **4.1.1 Purpose of analysis**

Each type of assessment differs in purpose. Tactical assessment (TA) is focused primarily on estimating the physical, functional and mission-related capabilities of individual target systems in response to attacks carried out against those systems. Operational assessment focuses on determining whether progress toward planned, desired effects is proceeding satisfactorily and, if not, what are the sources of the shortfalls and what changes to the operational plan can be made to achieve the desired effects in a timely manner. The emphasis on destroying, disrupting or neutralizing individual systems through the application of air power often will focus the attention and efforts of the TA team on kinetic effects. Any focus on non-kinetic effects often is implicit. The focus of operational assessment, on the other hand, is explicitly both kinetic and non-kinetic in its pursuit of effects. From the point of view of TA, an abandoned radar should be destroyed. From the OA point of view, a radar that is not being used to threaten friendly air assets represents a desirable outcome and progress toward an effect. That the radar is abandoned because leaflets convinced the crew to return home, rather than risk their lives to defend an assigned area, makes little difference to the achievement of the desired effect. Non-kinetic means enjoy the same effectiveness status as kinetic means for the operational assessor. The emphasis of TA on single systems, or small collections of systems, indicates a focus on local objectives and considerations. The operational assessor, on the other hand, focuses on more global considerations such as systems of systems (SoS), socio-economic structures and political considerations. There also is a concern with interactions between these “systems” on the part of the operational assessor. Tactical assessment focuses on first-order effects. Operational

assessment attempts to account for effects at the second-order and beyond. Thus, complex causal analysis is more of a concern for OA than for TA. A major purpose driving TA is a concern with reconstitution, re-assignment and re-attack. That is; when will a system, previously disabled, be re-enabled; when should a system be attacked again; and what assets should be assigned or re-assigned to carry out a strike. Conversely, a major concern of OA is with re-allocation. The fundamental question is: In order to maintain (or regain) satisfactory progress toward desired effects, what and how do resources need to be re-allocated, relative to current allocations.

#### 4.1.2 Objects of analysis

These two types of assessment also differ in the objects of their analysis. The primary objects of analysis in TA are physical systems: radars, airfields, command buildings, power stations and other physical installations. Operational assessment, by contrast, takes both physical and conceptual systems as its objects of analysis. In addition to the physical objects enumerated above, OA also concerns itself with political, economic and social systems. The systems that each type of assessment considers will range from single systems, in the case of TA, to systems-of-systems (SoS), in the case of OA. The operational assessor also will be concerned with the interactions among systems as well as the systems themselves. When considering networks, the tactical assessor will concentrate on single nodes of networks. Operational assessors, conversely, will be concerned with entire networks and the relationships between these networks.

#### 4.1.3 Workflow characteristics

These two types of assessment also differ in their workflow characteristics. The workflow that best characterizes TA is linear in nature, proceeding from early analysis Bomb Damage Assessment (BDA) through successive stages to late analysis Mission Effects Assessment (MEA). The workflow of OA is more non-linear in character. The operational assessor performs analysis on plan elements that are not arranged in a strict hierarchy (although there is often some priority set on operational objectives). Thus, analytical focus will move among plan elements and other tasks in a non-linear manner. This implies that TA will be subject to a stricter sequencing than will be the case for OA. For example, in TA one performs BDA before Functional Damage Assessment (FDA). Each stage follows, more or less, logically on another. Operational assessors can better be described as exhibiting a “random access” of analytical objects as information about these objects becomes available or as other requirements prompt analysis. The final difference, again related to the discussion above, is that information arrival tends to follow a synchronous pattern in TA. Early information bears on the process of BDA, later information is relevant to other processes (Physical Damage Assessment, FDA, MEA, etc.). Information availability is more asynchronous in OA. Information relevant to the assessment of operational plan elements is made available to the OAT in a first-arrival, first-announced manner, more or less independent of plan element priority, OAT request, the ATO in force, point in the air campaign or other factors.

#### 4.1.4 Types of decisions and decision processes

These differences in purpose, objects of analysis and workflow naturally lead to differences in the types of decisions between TA and OA. The decisions made by tactical assessors are concerned with sequencing and/or scheduling, state estimation, and assignment. These derive from the emphases in TA on reconstitution, re-assignment and re-attack. These requirements drive tactical assessors to be concerned with the problem of how to manage assets in ways that will satisfy these emphases, while maintaining the integrity of the effects-based plan and operational tempo of the overall air campaign. The major criterion underlying these types of decisions for the tactical assessor, then, will be that of optimization. The decision categories that apply to OA, on the other hand, include decisions focusing on plan modifications, diagnosis and troubleshooting, and allocation. In evaluating an Effects-Based Plan (EBP) the OAT will inevitably encounter deviations of actual results from those planned to occur, with respect to either degree of conformance or time (e.g., are we on schedule?). When these occur, operational assessors will troubleshoot the situation to locate the sources of the shortfall and then attempt to diagnose the causes. When this activity has been successful they will recommend steps that either put the air campaign back on track or adapt the plan to better fit the evolving operational environment. These decisions will often be accompanied by allocation recommendations. These coordinated decisions on the part of operational assessors are complex and interdependent. It is virtually impossible to approach any degree of optimization in making them. Instead, operational assessors pursue a relaxed criterion throughout this process. The assessors try to make decisions that are “good enough” for the conditions under which they operate.

#### 4.1.5 Criteria for success

Each type of assessment, therefore, uses different criteria for success. Tactical assessment attempts to optimize resources and maintain strict schedules as accurately as possible. An important success measure for TA is the number of targets “serviced.” This includes maintaining the “service levels” of these targets throughout the course of the air campaign. Tactical assessors also strive to understand local effects. The primary criterion for Operational Assessment revolves around the tradeoff between achieving desired effects and minimizing the risks of that achievement. The OAT can maintain the “right” balance in this tradeoff by thoroughly understanding the causal structure of the air campaign and by attaining a global comprehension of air operations and their relationships to the overall operation. The importance of gaining an understanding of causal structure often is signaled in comments from operational assessors like “did our actions cause the effect I am seeing,” “are we doing the right things,” and “are we doing things right.”

Behavioral and cognitive differences between TA and OA are summarized in Table 1 below.

**Table 1: Summary Comparison of TA and OA**

	<b>Tactical Assessment</b>	<b>Operational Assessment</b>
<b>Purpose</b>	<ul style="list-style-type: none"> <li>• Kinetic &amp; non-kinetic</li> <li>• Local</li> <li>• 1<sup>st</sup> order</li> <li>• Reconstitution</li> <li>• Re-assignment</li> <li>• Re-attack</li> </ul>	<ul style="list-style-type: none"> <li>• Kinetic &amp; non-kinetic</li> <li>• Global</li> <li>• Nth order</li> <li>• Re-apportionment</li> <li>• Re-allocation</li> </ul>
<b>Objects of Analysis</b>	<ul style="list-style-type: none"> <li>• Physical</li> <li>• Single systems</li> <li>• Single nodes of networks</li> </ul>	<ul style="list-style-type: none"> <li>• Physical &amp; conceptual</li> <li>• SoS &amp; their interactions</li> <li>• Networks</li> </ul>
<b>Workflow Differences</b>	<ul style="list-style-type: none"> <li>• Linear</li> <li>• Strict sequencing</li> <li>• Synchronous</li> </ul>	<ul style="list-style-type: none"> <li>• Non-linear</li> <li>• “Random access”</li> <li>• Asynchronous</li> </ul>
<b>Types of Decisions</b>	<ul style="list-style-type: none"> <li>• Sequencing/scheduling</li> <li>• State estimation</li> <li>• Optimizing</li> <li>• Assignment</li> </ul>	<ul style="list-style-type: none"> <li>• Plan alterations</li> <li>• Diagnosis/troubleshooting</li> <li>• Satisficing</li> <li>• Allocation</li> </ul>
<b>Decision Processes</b>	<ul style="list-style-type: none"> <li>• Directed search</li> <li>• Confirmatory</li> <li>• Constructive</li> </ul>	<ul style="list-style-type: none"> <li>• Opportunistic search</li> <li>• Diagnostic</li> <li>• Integrative</li> </ul>
<b>Criteria for Success</b>	<ul style="list-style-type: none"> <li>• Resources optimized</li> <li>• Schedules maintained</li> <li>• Targets neutralized</li> <li>• Local effects understood</li> </ul>	<ul style="list-style-type: none"> <li>• Effects produced</li> <li>• Risk minimized</li> <li>• Causal structure understood</li> <li>• Global comprehension of ops</li> </ul>

## **5. Structure of the OEAVT Development Team**

SAIC assembled a multidisciplinary team to carry out the OEAVT effort. In keeping with our general development methodology for joint cognitive systems, disciplinary participants for the team were defined at the beginning of the project and remained throughout the project, thereby ensuring that all important aspects of the system development remained in the forefront from early analysis to later software engineering. The SAIC team consisted of scientists and engineers in cognitive science, systems engineering, software engineering and assessment operations. Additionally, non-SAIC team members included experts in the AOC and TBMCS, cognitive system engineers involved in the Phase I cognitive task analyses, and SMEs possessing experience in operational (and tactical) assessment. In keeping with the nature of the system under development and the work being supported, the project was led by a cognitive scientist.

### **5.1 Subcontractors**

Each of the subcontractors on the OEAVT project provided a specific contribution to development. Lockheed-Martin, Inc. brought prior AOC and specific TBMCS operational and integration experience to the project. The ManTech Cognitive Systems Engineering Center (CSEC) provided continuity from the “AOC Strategy Division Decision Analysis” Phase I effort in the form of previous Strategy Division cognitive task analyses. They also produced visualization concepts for indicator management that were incorporated into the AECV and module of OEAVT. These will be discussed in a later section of this report. Securboration, Incorporated and L3 Communications, Incorporated provided Subject Matter Experts throughout the life of the program. Their assistance in initial analysis of operational assessment, formulation of a system model and subsequent requirements, and ongoing evaluation of concepts through several developmental stages were invaluable in keeping the development team on the right track and producing the right product for the assessment task and the warfighters carrying out assessment. The Securboration SME also provided access to the Operational Assessment community and served as liaison to the Dynamic Air and Space Effects-based Assessment (DASEA) program.

## 6. OEAVT Program Challenges

There were three areas of complexity faced by the OEAVT program: The systems of record challenge, integration challenges across new system development efforts, and the general evolution of the OA concept.

The presence of TBMCS and IWPC as systems of record in the AOC led to challenges. At the outset of the OEAVT program, it was assumed that the visualization capability developed by the OEAVT team would integrate with, or otherwise rely on, these systems of record. However, other organizations were developing potential replacements for these systems. Thus, there was uncertainty as to what environment OEAVT would have to interact with during operations. The IWPC system was reaching its end of life as the OEAVT program was beginning. However, no replacement had been selected as late as the halfway point of OEAVT. This left the visualization capability of OEAVT in need of a computational engine to carry out much of the lower-level tasking upon which assessment depends; including search functions, some data fusion, and tactical level computation and roll-up. While the best “vision” for success would have been to have OEAVT ride “on top of” such a computational engine, this integration was not achieved.

Throughout the life of the program several other development efforts were underway. Each of these was addressing an aspect of the OA problem, sometimes in ways complimentary to OEAVT and sometimes in redundant ways. As one would expect, the existence of these separate efforts posed integration challenges for a complete, seamless solution to OA support. Of particular significance in this regard was the development, and later cancellation, of Theater Battle Operations Net-Centric Environment (TBONE). TBONE represented the future integrated information backbone for the AOC. With the cancellation of this effort, no integrated information capability exists within the Strategy Division, nor is one expected for the foreseeable future. Since TBONE was cancelled in the middle of the OEAVT program, a shift in focus was required, due to the loss of expected information services from TBMCS 1.1.3. Instead, a hodgepodge of disparate systems will continue to be a significant challenge for developers and operators alike. As a result, largely manual activities supporting operational processes will remain the norm. The fact remains that realization of effective and efficient operations absolutely requires automation advances far beyond what we are seeing today.

Finally, the evolution of the OA concept has continued to evolve throughout the life of the OEAVT program. The Strategy & Assessment Requirements Sub-Working Group was created by the AFC2ISRC prior to the start of the OEAVT program. It has served as the main interface between Air Combat Command (ACC) and the OEAVT program. It has provided a forum for discussing assessment requirements, as well as associated issues and ideas. In addition, it has been the organizational forum for bringing together warfighters and developers on a regular basis. A challenge that, at least from the OEAVT point of view, was not addressed during the program was an inability to fully integrate requirements developed by different groups involved in addressing aspects of operational assessment. Requirements for OA were developed from at least four points of view, across as many organizations. These included an operational point of view, a systems engineering point of view, a software point of view and a cognitive engineering point of view. Unfortunately, there was no complete integration of these requirements. Subsequently, system developments based on these disparate requirements diverged rather than converging toward mutual support.

## **7. Description of Cognitive Systems Engineering Methodology Underlying OEAVT Development**

The SAIC team relied on an adaptation of “conventional” Cognitive Systems Engineering (CSE) methods and processes throughout the analysis, design and development phases of the OEAVT program. We describe the methodology in this section. Our application of the methodology to the development of the OEAVT system is described in section 9.

Our methodology is based on the firm conviction that adequate development of visualization and decision support systems must be guided by a thorough understanding of the operational, behavioral and collaborative factors at play in the work domain being addressed. A crucial concept in this stance is that the to-be-developed system should provide adaptive support to its users. This can be contrasted with more traditional approaches that strive to automate critical work processes and/or replace humans with synthetic “operators.” The OEAVT team adapted this conventional viewpoint by developing a methodology that integrated cognitive systems techniques and artifacts with rigorous system engineering and software development processes.

### **7.1 Domain analysis and derivation of perceptual/cognitive requirements**

The application of this methodology to the support of visual thinking begins with a CSE analysis. Our analysis typically focuses on five areas. First, a work domain analysis is conducted to gather information about goals and requirements present in the domain of the design, work constraints and dependencies, opportunities or affordances utilized by workers, and the functions and physical forms of current technologies. Second, control task analysis identifies required activities, tasks and workflow relationships inputs, outputs, and knowledge states required to support successful work in the domain of interest. Third, we identify strategies used to execute activities and tasks. Our focus here is on critical cues and other triggering conditions for each of the tasks, critical decisions, common errors, communication patterns, and tools used to carry out the work, and the data products used during task accomplishment. Fourth, we identify the socio-technical factors present in the domain. Relevant information includes organizational structures, conditions that trigger changes to these structures (e.g., conditions creating ad hoc teams), and coordination/collaboration dynamics. Fifth, we identify perceptual and cognitive competencies required for success in the domain. We characterize these as perceptual and cognitive work elements used to manage work, achieve associated goals, and collaborate with teammates. We collect this information into a set of structured concept maps containing the information enumerated above.

## **7.2 Map CSE results to system engineering requirements analysis activities and products**

A thorough CSE analysis is a necessary, but not sufficient, part of successful system design. Unless the information gathered during CSE analysis is meaningfully integrated with system engineering requirements analysis, then it remains a disconnected data set, too often ignored by system developers. We avoid this problem by explicitly mapping CSE analysis results to system engineering requirements analysis and products. We define 11 system engineering requirements analysis activities, as shown in the center section of Figure 3.

Most of these activities constitute functional analysis. However, two of the remaining categories are crucial to success because they explicitly define both the goals of the system under design and constraints that will come into play during the design. Cognitive and traditional system engineers participate in this mapping exercise, explicitly identifying where each result of the CSE analysis will be placed within the system engineering functional analysis. This often requires some re-casting of terminology and level of specification contained in the CSE analysis. This is desirable, as it helps to translate the CSE analysis into a form appropriate for system requirements analysis and facilitates a close working partnership between the CSE analyst and system engineer. Most importantly, performing this mapping ensures that information gathered during the CSE analysis is included in the system engineering requirements analysis products that will be used to guide subsequent system development.

### CTA Analysis Products

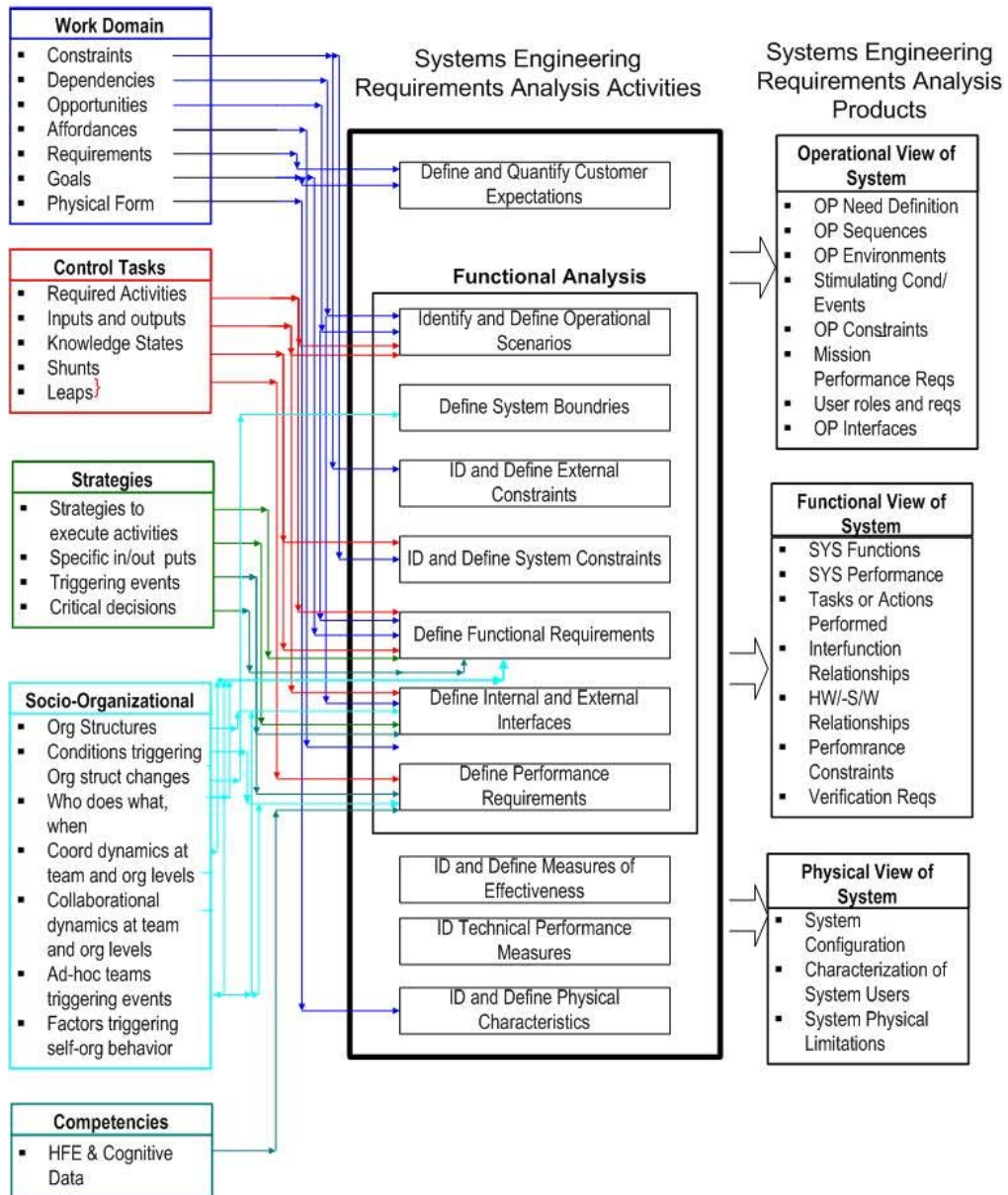

**Figure 3: CSE to System Engineering Requirements Mapping**

### **7.3 Develop a system model**

All the information from the previous analyses then is used to develop a set of system engineering models in CORE, a commercially available case tool that allows management of the entire development project from this point onward. Working with SMEs, we develop a set of hierarchically organized diagrams of the work domain that includes information about system functionality, inputs and outputs, sequence, constraints and dependencies, triggering conditions and end-states and so on. Because we perform the CSE – system engineering analysis mapping discussed above, we can be confident that the information gathered during the CSE analysis will be included in the system engineering model developed at this stage of the design.

### **7.4 Derive system requirements**

The completed CORE diagrams form the basis of requirements identification. System requirements can be generated automatically by the CORE system. These system requirements then are augmented with requirements identified by mapping the CORE-generated set against the concept maps and other artifacts of the CSE analysis. Each requirement is labeled with a reference to its source and color-coded to indicate whether it is a system-only requirement or a requirement involving user participation with the system under design.

### **7.5 Map requirements to perceptual/cognitive work elements**

We can be confident, at this point, that the information gathered during CSE analysis is represented in the requirements that will guide system design. What remains is the crucial step of explicitly relating the requirements to visualization design. We accomplish this in two steps: first, by mapping each requirement to the perceptual and cognitive work elements that will satisfy it and second, by creating an executable model of each requirement. We discuss the first step here. The second step will be discussed in the next section.

Imagine the following requirement for a visualization system designed to support Effects-Based Assessment (EBA):

*The system shall provide a way to derive intended and unintended effects from tactical assessment results.*

Clearly, certain competencies must be used to satisfy this requirement. We identify these by referring to the concept maps developed during CSE analysis. In this example, the requirement above can be satisfied with a combination of the following work elements: abduction (inference to the best explanation), acquisition, classification, detection, evaluation, interpretation and recognition. Referring to the concept maps we enter applicable work elements into a spreadsheet opposite a list of the system requirements, one set of work elements for each requirement. If there are elements that do not apply to any requirement, then either the element is used unnecessarily in the concept maps or a requirement is missing from the system engineering analysis. The concept maps thus provide the database containing work elements required to satisfy requirements. These elements will usually comprise a relatively small set but will, in the right combinations, successfully address a large collection of requirements. Once each requirement has been assigned one or more perceptual and cognitive elements, we are ready to begin the creation of executable models.

## 7.6 Visualization Design

Each cognitive and perceptual element has basic visualization requirements defined for it that we assume are consistent across contexts. For example, the cognitive element *compare* involves examining two or more objects in terms of their similarities and differences. The visualization requirements for this element include displaying the attributes and values of objects being compared to users. Further, these “objects” should be displayed in a way that facilitates the comparison being carried out, that is, by highlighting the similarities and differences through some method of ranking, coding or some other means. As this example shows, there will be a basic structure associated with each element as well as performance parameters for the elements. Parameters for *compare* might include the number of to-be-compared elements that can be held in short-term memory and sensitivity limitations on attribute similarity used in comparisons.

The requirements provide the context, constraints and boundaries of visualization design for each primitive element. Thus, while the basic requirements will not change across elements the values of parameters associated with modeling of elements will change according to the context of each requirement. Consider, for example, a requirement to compare an air attack result against a target, located close to a mosque, with the intended point of attack to assess progress toward an effect. In this case the sensitivity parameter for the comparison would be set to a high value, since collateral damage to the mosque would lower the assessment of success toward effect. The comparison of planned to actual result would indicate success only if the attack were extremely precise, that is, resulted in no damage to the mosque.

By this method we develop visualization concepts for each primitive in context. Common requirement/primitive combinations are collected together into common visualization concepts. The individual concepts then are aggregated into higher-level collections to form visualizations at the screen level. This process is iterated against the CORE functional model, thereby allowing validation of visualizations by ensuring that the system follows the processes outlined in that model.

## 8. OEAVT OA Cognitive and Work Analysis

The process used in developing the OEAVT system was based on a CSE methodology created from the system engineering and integration point of view (as outlined above). That is, CSE was defined to be an integrated member in an overall system engineering and development process leading to working operational systems. This is in contrast to a philosophy that defines CSE as the lead discipline in system development efforts. In the disciplinary partnership that results from the former philosophical model, CSE analysis strives to satisfy two objectives simultaneously. This first goal is to carry out the analyses needed to clearly understand the nature of the work involved in operational assessment. If successful, this understanding will include organizational, socio-technical and collaborative processes in addition to the more traditional processes involved in the work of individual operators. The second goal of this type of CSE analysis is to gather the content, and communicate that content, in a manner that can be best used in identifying system requirements and defining a system model that includes the important CSE considerations uncovered in the originating analysis. The methodology described below satisfies these two objectives.

We began the OEAVT project with a CSE analysis of operational assessment. The analysis was based on four sources of information. Previous analyses had been conducted in an earlier phase of the program. Although these analyses focused on the overall processes used across the Strategy Division rather than specifically on detailed assessment processes, they were useful as baseline material to inform our analyses. Operational documents formed another important source of information for our analyses. These included the AFOTTP that was currently in effect at the time of the analyses, briefings and instructional materials focused on operational assessment, results of the Air Force Assessment Task Force (ATF) meetings on definitions, processes, lexicon and nomenclature regarding operational assessment. Our third information source was that of observations and interviews conducted at operating locations, exercises and working meetings. These included International North Atlantic Treaty Organization (NATO) Exercises, Joint Expeditionary Forces Experiment (JEFX) and the April 2006 Warfighter Analysis Workshop (WAW). The final, and most important, source of information was that provided by the SMEs on the SAIC development team. We relied on two SMEs throughout the life of the project. These two experts were uniquely positioned to inform our analyses of assessment and to provide ongoing design assistance and evaluation throughout development. One of these SMEs developed and taught Operational Assessment at the 705<sup>th</sup> Command and Control Unit. The other SME was the Assessment Team Chief at the 8<sup>th</sup> Air Force when the OEAVT project began. After leaving the Air Force he continued to play a crucial role in the development of Operational Assessment concepts on several programs in addition to OEAVT.

Our analysis was organized according to the five areas outlined by Vicente (1999). These included a work domain analysis, control task analysis, strategies analysis, socio-technical analysis and competencies/limitations analysis. We documented these analyses in a set of concept maps that were organized according to an ontology containing information in each of the five analytical categories enumerated above. The concept map ontology is shown in Figure 4. Our focus in the work domain analysis was on the structure and logical relationships present in the operations of the Strategy Division, with emphasis on OAT processes. Our work domain analysis focused on a number of categories important to the accomplishment of assessment,

including operational requirements, processes, and activities; data and data sources; triggers, pre-conditions and constraints; products and artifacts.

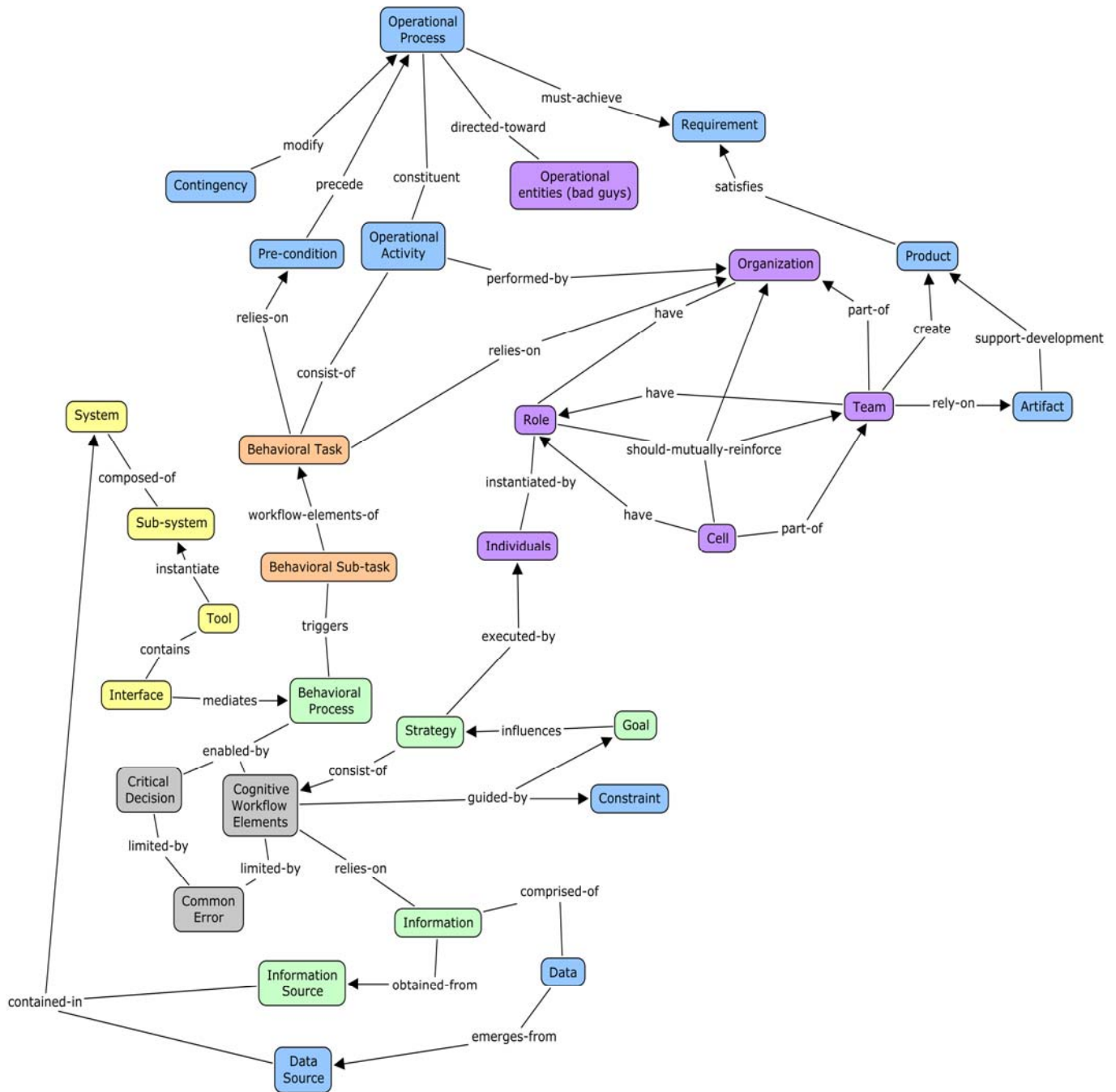

**Figure 4: Ontological Categories Used in the OEAVT CSE Analysis**

Control tasks were the focus of our second area of analysis. Vicente (1999) defines control task analysis as the identification of task requirements associated with known, recurring situations. Accordingly, our ontology included tasks and sub-tasks as elements of the control task analysis. Another crucial element of the control task analysis was to identify and characterize the critical decisions that operators made during the unfolding of assessment episodes. We used the critical decision method (Klein, Calderwood and McGregor, 1989) to supplement our control task analysis with these characterizations. Control tasks are shown as salmon-colored concepts in Figure 4.

The control task analysis was followed by a strategies analysis. Whereas control task analysis addresses the question of what needs to be done, strategies analysis asks how things are done. Our main emphasis in the strategy analysis for OEAVT was to focus on behavioral processes and cognitive work elements used by assessors to accomplish the control tasks required for operational assessment. Behavioral processes exist at the macro level, while cognitive work elements are micro-level processes. We also identified the information and information sources used to carry out these strategies; the goals, constraints, pre-conditions and contingencies that affected processes and work elements; and the errors that were common to strategy use. The investigation of strategies is, arguably, the most detailed and time-consuming analysis carried out in the overall CSE investigation. Program constraints often will limit the extent of this level of analysis, particularly at the Cognitive Workflow Elements (CWEs) level. That was the case for the OEAVT program. Thus, our cognitive workflow elements analysis was largely inferential in nature. That is, we inferred CWEs from the behavioral processes identified in the overall analyses of the work assessment environment. Our CWE analysis was then halted at the point of identification, and we moved on to system design activities.

Our socio-technical analysis concentrated on the systems and tools with which assessors must interact and on the organizations and teams involved in assessment. One factor that is not often appreciated about the AOC environment is the number and diversity of systems that play a role (both positive and negative) in the development of new technology like OEAVT. Legacy systems and evolving technology had to be taken into consideration during the design of OEAVT. Some of these systems represented “services” that OEAVT either would have to use or might benefit from. Others represented candidate “hosts” within which OEAVT might reside. Similarly, tools provided both beneficial and non-beneficial influences. Chief among these was Microsoft Excel, used by many of the assessment teams for a variety of tasks. The challenge of this tool was that each team had adapted it to their unique needs and methodologies, thereby posing a challenge for the evolution of OEAVT as a single tool. The organizational leg of our socio-technical analysis was concentrated on the formal organizations and teams involved in (we used this term broadly) assessment, as well as on the informal, ad-hoc teams that formed and “de-formed” as assessment progressed over time. Organizational information that we identified included formal organizational identity, defined and ad-hoc teams, and roles played by these entities.

The fifth aspect that we considered was that of capabilities and limitations associated with the tasks and processes of assessment. Normally, such an analysis would consider many of the cognitive and perceptual limitations that are common in the human factors engineering analysis of performance in time-critical, highly risky operations. However, time and resource limitations on the OEAVT design team, along with the fact that assessment is not as sensitive to these performance concerns, led us to relax this analysis. Accordingly, we concentrated only on time, information requirements and complexity in our capabilities and limitations analysis.

The concept maps developed in the early stages of the OEAVT program are shown in Appendix A. Fourteen concept maps were developed, covering pre-execution and execution phases of the air campaign. As can be seen, several of the concept maps apply to operational processes normally associated with tactical assessment. These include BDA, functional damage assessment, physical damage assessment and mission effects assessment. Their presence in our analysis indicates that the separation between tactical and Operational Assessment was not straightforward at the time the concept maps were developed. In fact, both of the SMEs participating in our analysis recommended that the OEAVT team include these concept maps in our overall analysis. That they are not developed to a great level of detail indicates (1) the uncertainty on the part of the SMEs about where the line between tactical and Operational Assessment should be drawn and (2) the feeling on the part of the design team, after further document review, discussion with additional operational personnel and observation of operational exercises; that these processes did, in fact, fall more on the tactical side of the line. The remaining concept maps in Appendix A captured our analysis of Operational Assessment at varying levels of detail befitting the time available for this phase of analysis and the perceived centrality of the process to assessment overall. The concept maps were supplemented with information from the critical decision analysis. This information is presented in the spreadsheets contained in Appendix A. In these spreadsheets, the critical decisions arising from the Cognitive Work Requirements (CWR) identified in Phase I were enumerated along with information requirements, common errors and other information needed to design adequate assessment support. The information from the concept maps and that from the critical decision analyses were combined together and; along with documentation from operational sources, informal contacts with operational personnel and SMEs outside the project, attendance at exercises and other operational events, and participation in assessment working groups; formed the basis for system engineering analyses and requirements development.

Prior to the development of system requirements the design team identified cognitive workflow elements (CWE) needed to successfully execute assessment strategies. The CWE were identified by analyzing the control task and strategy information in each of the concept maps and critical decision matrices. Table 2 contains the CWE that were identified in this manner. The purpose of this analysis was to identify a set of elements, exhaustive in their coverage of assessment that could be used to create a traceability matrix relating specific design commitments in the OEAVT interfaces and operating logic to the system requirements.

**Table 2: Cognitive Workflow Elements (CWE) Identified from the CSE Artifacts**

Acquire	Communicate	Discriminate	Infer	Monitor
Aggregate	Compare	Estimate	Integrate	Plan
Assign	Decide	Evaluate	Identify	Prioritize
Choose	Describe	Generate	Interpret	Recognize
Classify	Detect		Match	Verify

## 9. OEAVT System Engineering

The development of the engineering model and system requirements for OEAVT followed a structured process based in traditional systems analysis extended to include the products of cognitive analysis. An overview of the process is illustrated in Figure 5. Products from the systems engineering processes (analysis, interviews, models, and requirements) were captured in the Systems Engineering tool CORE.

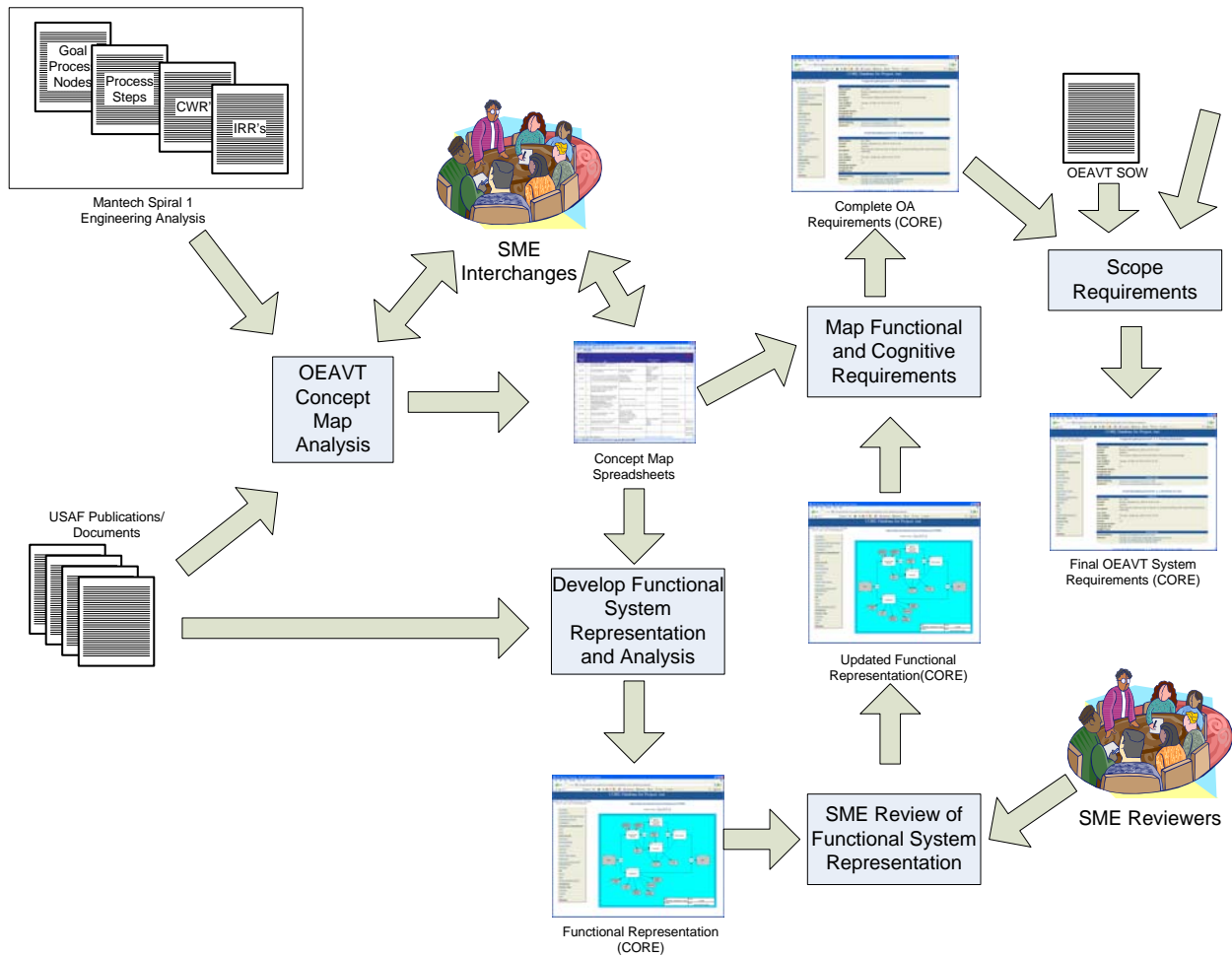

**Figure 5: System Analysis Process**

## 9.1 Step 1: Perform OEAVT Concept Map Analysis

The first step in the process was to perform concept map analysis. Section 9 describes the process that the OEAVT team used to develop the concept maps for the Operational Assessment activities in the AOC and provides a detailed description of the development and analysis process and activities. The output of the concept map analysis included both the ManTech Spiral 1 and 2 cognitive engineering analysis products (such as Goal Process Nodes (GPN), Process Steps (PS), Cognitive Work Requirements (CWR) and the Information Relationship Requirements (IRR)) and a set of spreadsheets that contained engineering requirements developed using the concept map analysis. The CORE database schema had to be extended so that the GPN's, PS's, CWR's, IRR's, and workflow information could be stored and the relationship between these specific attributes could be represented in CORE. The document or analysis source(s) of each CORE entry were logged permitting attribution for each cognitive analysis product. Figure 6 (below) illustrates a sample CORE page showing a GPN, the source of the data, and supporting relationships.

The screenshot shows a web browser window titled "CORE Database Homepage - Microsoft Internet Explorer". The main heading is "CORE Database for Project: OEAVT". Below the heading, there is a navigation menu with the following items: Activities, Cognitive Work Requirement, CompletionCriterion, Constaints & Dependencies, CWR, Data, Data Sources, Document, Engineer, ExternalGraphic, Function, Goal Process Node, Implication, Information Relationship Requirements, IRR, Issue, Item, Participants, Process Step, Products, and Workflow. The main content area displays the details for "Goal Process Node: 3.2 Successfully Infer Adversary Goals".

Attributes	
<b>Abbreviation</b>	
<b>Created</b>	Monday, December 13, 2004 at 02:09:58 PM
<b>Creator</b>	Overdorf
<b>Description</b>	The purpose of GPN 3.2 (Infer Adversary Goals) is to develop and maintain an understanding of adversary end-states that may impact Aerospace Objectives (GPN 1.1). GPN 3.2 (Infer Adversary Goals), thus, supports the selection of Aerospace Objectives (GPN 1.1), by providing information about end-states the coalition believes the adversary desires (or should desire). The identification of Adversary Goals is supported by Posited Adversary Capabilities (GPN 3.4) and inferences about Adversary Will (GPN 3.6). Propositions about Adversary Capabilities foster identification of the adversary's dangerous and likely goals. Inferences about Adversary Will help to ensure that Inferred Adversary Goals are not constrained by assumptions of a rational adversary. Because GPN 3.2 produces inferences about Adversary Goals (only the adversary knows their goals with certainty), inference validity is a constant concern. As a result, the inputs that support inferences about Adversary Goals must be monitored continuously. Indicators (GPN 4.4) support the continuous assessment of Inferred Adversary Goals.
<b>Last Modified</b>	Tuesday, December 14, 2004 at 03:08:36 PM
<b>Number</b>	3.2
Relationships	
<b>Achieved By</b>	<a href="#">Process Step 3.2.a Potential Adversary Goals</a> <a href="#">Process Step 3.2.B Identify Relevant Adversary Goals</a> <a href="#">Process Step 3.2.c Inferred Adversary Goals</a> <a href="#">Process Step 3.2.d Assess Adversary Goals</a> <a href="#">Process Step 3.2.e Assessed Adversary Goals</a>
<b>documented by</b>	<a href="#">Document 2 Spiral 2 -Aerospace Command&amp;Control Cognitive Analysis Report</a>
<b>Monitored By</b>	<a href="#">Cognitive Work Requirement 3.2.x.2 Evaluate quality of inferred adversary goal set</a> <a href="#">Cognitive Work Requirement 3.2.x.3 Monitor extent to which inferred adversary goal set provides information for the development of aerospace</a> <a href="#">Cognitive Work Requirement 3.2.x.4 Assess potential for inferred adversary goals to impact aerospace objectives</a>
<b>owned by</b>	<a href="#">Engineer Overdorf</a>
<b>reveals</b>	<a href="#">Implication GPN 3.2 Implications</a>

Figure 6: CORE Database

## 9.2 Step 2: Develop Functional System Representation and Analysis

The next step in the process was to develop a model of the Operational Assessment process within the AOC. Air Force documentation was examined to discover the documented (or expected way) that Operational Assessment was to be conducted. AFTTP 2-3.2 was used extensively to identify tasks/activities that were required in the Operational Assessment process, the sequencing of these tasks, inputs to the tasks and outputs from the tasks. Activity networks were developed in a “top down” manner starting with high-level tasks or activities. Figure 7 (below) illustrates the top level AOC functional description of operational assessment. Each of the top-level tasks was then further decomposed to reveal progressively lower level assessment operations. Figure 8 reveals a decomposition of Operational Assessment during the execution phase of the conflict. At each level of decomposition, information/products required for the task, and information/ products produced by a task were documented. Figure 9 shows a decomposition of the “Analyze Operational Results” task and the associated task inputs, outputs and task triggers. CORE supports the network representation (and output) in a variety of notations (FFDB, enhanced FFDB, IDEF0, and N2). Different views were used depending on if they enlightened activity relationships or better-revealed sequencing. The source of the information for the identified tasks was traced to the information source in the “documented by” field.

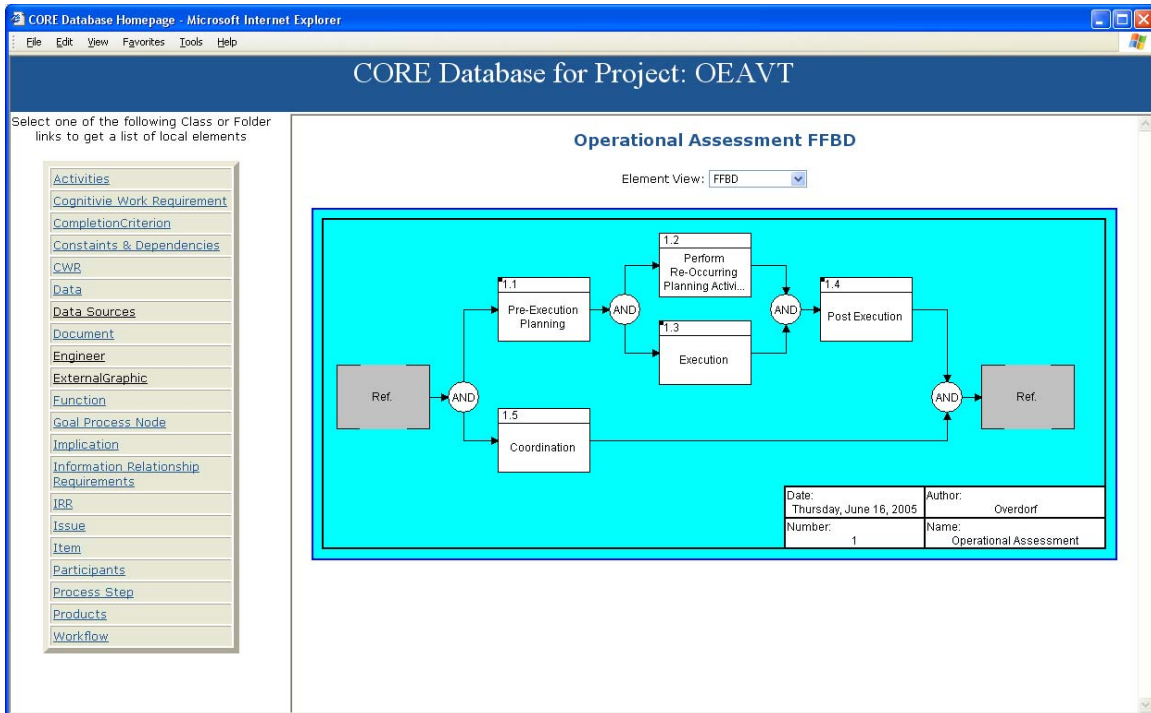

Figure 7: Top Level Operational Assessment Task Diagram

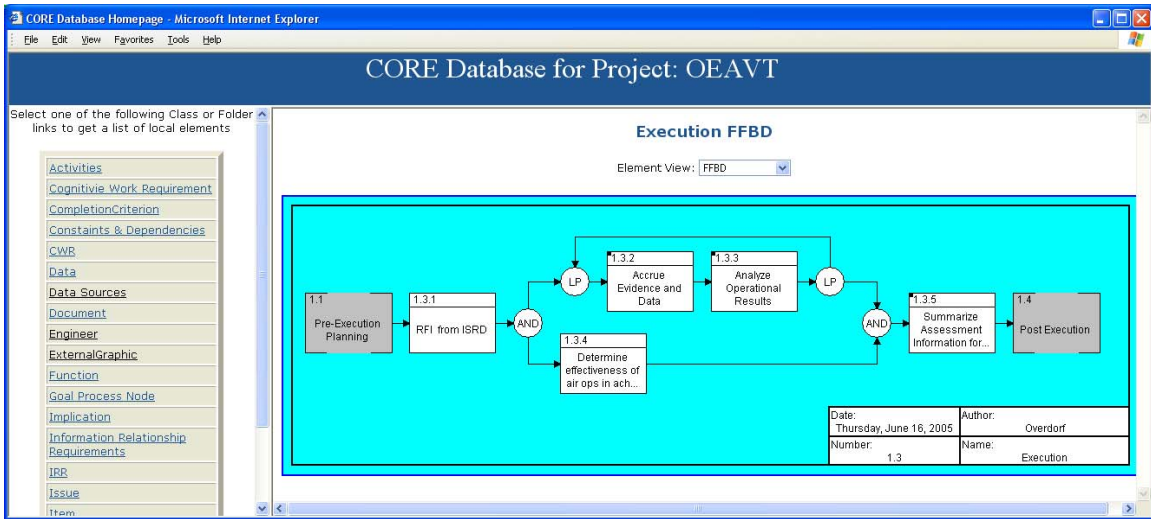

Figure 8: Decomposition of the “Execution” Operational Task

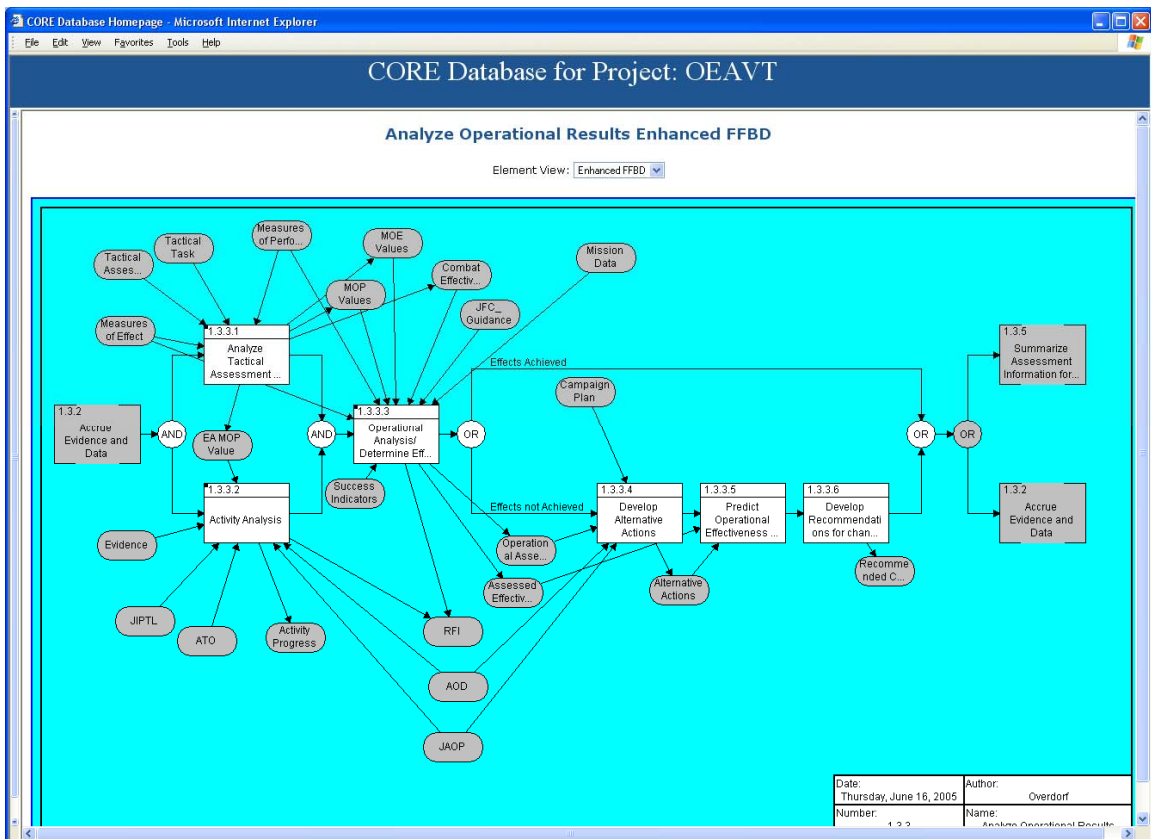

Figure 9: “Analyze Operational Results” Decomposition

The OEAVT model is documented as a hardcopy set of Enhanced Functional Flow Block Diagrams generated by CORE and a set of interactive “html” browser forms. Appendix B contains the hardcopy set of model diagrams.

### **9.3 Step 3: SME Review of Functional Representation**

The next step in the process was to review the “doctrinally correct” Operational Assessment process network with SMEs from the assessment community. Over a series of sessions, the SMEs reviewed each task, the inputs/outputs, and the sequencing from the drawing. Often, they provided additional details that permitted the network to be revised and corrected and the process better understood. Occasionally, they provided insight into differences between Operational Assessment as a concept and Operational Assessment as practiced in the AOC. Each change by an SME was noted in CORE and attributed to the particular SME. At the completion of this step, a baseline model of Operational Assessment was in-place.

### **9.4 Step 4: Map Functional and Cognitive Requirements**

The baseline model of Operational Assessment highlighted what must be done to perform Operational Assessment in the AOC. The next step in the process involved the creation of a set of system requirements for OEAVT that would permit it to support all of the OA tasks on at least some level. Each function in the network was examined to determine if, and how, OEAVT might support the function. The OEAVT tool was assigned a set of system requirements for each function that provided the specified level of support. These requirement assignments were broadly scoped and targeted for a “large scale” OEAVT implementation encompassing almost all assessment tasks. Layered on these requirements, were the cognitive requirements developed in the concept map analysis associated with cognitive work, information, and workflow. Each requirement was entered as an “Originating Requirement” (CORE name) and linked to the function and related analysis. Figure 10 illustrates an example of a function (“RFI from ISR”) and shows the functional hierarchy, supporting documents, outputs, and originating requirements.

CORE Database Homepage - Microsoft Internet Explorer

File Edit View Favorites Tools Help

## CORE Database for Project: OEAVT

Select one of the following Class or Folder links to get a list of local elements

	Attributes																																								
<ul style="list-style-type: none"> <li><a href="#">Activities</a></li> <li><a href="#">Annotation</a></li> <li><a href="#">Cognitive Work Requirement</a></li> <li><a href="#">CompletionCriterion</a></li> <li><a href="#">Component</a></li> <li><a href="#">Constraints &amp; Dependencies</a></li> <li><a href="#">CWP</a></li> <li><a href="#">Data</a></li> <li><a href="#">Data Sources</a></li> <li><a href="#">Document</a></li> <li><a href="#">ExternalGraphic</a></li> <li><a href="#">ExternalText</a></li> <li><a href="#">Function</a></li> <li><a href="#">Glossary</a></li> <li><a href="#">Goal Process Node</a></li> <li><a href="#">Implication</a></li> <li><a href="#">Information Relationship Requirements</a></li> <li><a href="#">Interface</a></li> <li><a href="#">IRR</a></li> <li><a href="#">Issue</a></li> <li><a href="#">Item</a></li> <li><a href="#">OriginatingRequirement</a></li> <li><a href="#">Participants</a></li> <li><a href="#">Process Step</a></li> <li><a href="#">Products</a></li> <li><a href="#">System</a></li> <li><a href="#">Text</a></li> <li><a href="#">Workflow</a></li> </ul>	<h3 style="text-align: center;">Function: 1.3.1 RFI from ISRD</h3> <table border="1" style="width: 100%; border-collapse: collapse;"> <tr> <td><b>Abbreviation</b></td> <td></td> </tr> <tr> <td><b>Created</b></td> <td>Friday, March 04, 2005 at 01:13:39 PM</td> </tr> <tr> <td><b>Creator</b></td> <td>Overdorf</td> </tr> <tr> <td><b>Description</b></td> <td>This is an Assessment Team request for information to ISRD based on the operational plan AFOTTP 3.5.5.2.7: Coordinate Request for Information (RFI), collection, and production requirements with the ISRD to ensure continuous support of OA functions and processing activities and especially the analysis and evaluation of the effects achieved by joint air operations</td> </tr> <tr> <td><b>Doc. PUID</b></td> <td></td> </tr> <tr> <td><b>Duration</b></td> <td></td> </tr> <tr> <td><b>Execution Level</b></td> <td>Follow Decomposition</td> </tr> <tr> <td><b>Last Modified</b></td> <td>Tuesday, February 14, 2006 at 11:15:56 AM</td> </tr> <tr> <td><b>Log Message</b></td> <td></td> </tr> <tr> <td><b>Number</b></td> <td>1.3.1</td> </tr> <tr> <td><b>Priority</b></td> <td></td> </tr> <tr> <td><b>Query Criterion</b></td> <td></td> </tr> <tr> <td><b>Timeout</b></td> <td></td> </tr> <tr> <th colspan="2" style="text-align: center;">Relationships</th> </tr> <tr> <td><b>_accomplished-by</b></td> <td><a href="#">Workflow Not on CMAPS</a></td> </tr> <tr> <td><b>augmented by</b></td> <td><a href="#">ExternalGraphic Execution</a> <i>Position: 1</i></td> </tr> <tr> <td><b>decomposes</b></td> <td><a href="#">Function 1.3 Execution</a></td> </tr> <tr> <td><b>documented by</b></td> <td><a href="#">Document 4 AFOTTP 2-3.2 Non-Draft Version</a> <a href="#">Document 8 Ken Morrow Interview</a> <a href="#">Document 11 SME Meeting June 2005</a></td> </tr> <tr> <td><b>outputs</b></td> <td><a href="#">Item RFI</a></td> </tr> <tr> <td><b>traced from</b></td> <td><a href="#">OriginatingRequirement 2.6.2 Access to Mission Outcome data</a> <a href="#">OriginatingRequirement 2.6.3 Access to Adversary data</a> <a href="#">OriginatingRequirement 6.1.2 Request CA Info</a> <a href="#">OriginatingRequirement 6.3.1 Access to ISR data</a> <a href="#">OriginatingRequirement 7.2.3 Access Adversary data</a> <a href="#">OriginatingRequirement 10.12 Request Intel Info</a></td> </tr> </table>	<b>Abbreviation</b>		<b>Created</b>	Friday, March 04, 2005 at 01:13:39 PM	<b>Creator</b>	Overdorf	<b>Description</b>	This is an Assessment Team request for information to ISRD based on the operational plan AFOTTP 3.5.5.2.7: Coordinate Request for Information (RFI), collection, and production requirements with the ISRD to ensure continuous support of OA functions and processing activities and especially the analysis and evaluation of the effects achieved by joint air operations	<b>Doc. PUID</b>		<b>Duration</b>		<b>Execution Level</b>	Follow Decomposition	<b>Last Modified</b>	Tuesday, February 14, 2006 at 11:15:56 AM	<b>Log Message</b>		<b>Number</b>	1.3.1	<b>Priority</b>		<b>Query Criterion</b>		<b>Timeout</b>		Relationships		<b>_accomplished-by</b>	<a href="#">Workflow Not on CMAPS</a>	<b>augmented by</b>	<a href="#">ExternalGraphic Execution</a> <i>Position: 1</i>	<b>decomposes</b>	<a href="#">Function 1.3 Execution</a>	<b>documented by</b>	<a href="#">Document 4 AFOTTP 2-3.2 Non-Draft Version</a> <a href="#">Document 8 Ken Morrow Interview</a> <a href="#">Document 11 SME Meeting June 2005</a>	<b>outputs</b>	<a href="#">Item RFI</a>	<b>traced from</b>	<a href="#">OriginatingRequirement 2.6.2 Access to Mission Outcome data</a> <a href="#">OriginatingRequirement 2.6.3 Access to Adversary data</a> <a href="#">OriginatingRequirement 6.1.2 Request CA Info</a> <a href="#">OriginatingRequirement 6.3.1 Access to ISR data</a> <a href="#">OriginatingRequirement 7.2.3 Access Adversary data</a> <a href="#">OriginatingRequirement 10.12 Request Intel Info</a>
<b>Abbreviation</b>																																									
<b>Created</b>	Friday, March 04, 2005 at 01:13:39 PM																																								
<b>Creator</b>	Overdorf																																								
<b>Description</b>	This is an Assessment Team request for information to ISRD based on the operational plan AFOTTP 3.5.5.2.7: Coordinate Request for Information (RFI), collection, and production requirements with the ISRD to ensure continuous support of OA functions and processing activities and especially the analysis and evaluation of the effects achieved by joint air operations																																								
<b>Doc. PUID</b>																																									
<b>Duration</b>																																									
<b>Execution Level</b>	Follow Decomposition																																								
<b>Last Modified</b>	Tuesday, February 14, 2006 at 11:15:56 AM																																								
<b>Log Message</b>																																									
<b>Number</b>	1.3.1																																								
<b>Priority</b>																																									
<b>Query Criterion</b>																																									
<b>Timeout</b>																																									
Relationships																																									
<b>_accomplished-by</b>	<a href="#">Workflow Not on CMAPS</a>																																								
<b>augmented by</b>	<a href="#">ExternalGraphic Execution</a> <i>Position: 1</i>																																								
<b>decomposes</b>	<a href="#">Function 1.3 Execution</a>																																								
<b>documented by</b>	<a href="#">Document 4 AFOTTP 2-3.2 Non-Draft Version</a> <a href="#">Document 8 Ken Morrow Interview</a> <a href="#">Document 11 SME Meeting June 2005</a>																																								
<b>outputs</b>	<a href="#">Item RFI</a>																																								
<b>traced from</b>	<a href="#">OriginatingRequirement 2.6.2 Access to Mission Outcome data</a> <a href="#">OriginatingRequirement 2.6.3 Access to Adversary data</a> <a href="#">OriginatingRequirement 6.1.2 Request CA Info</a> <a href="#">OriginatingRequirement 6.3.1 Access to ISR data</a> <a href="#">OriginatingRequirement 7.2.3 Access Adversary data</a> <a href="#">OriginatingRequirement 10.12 Request Intel Info</a>																																								

**Figure 10: Core Example of a Function and the Associated Originating Requirements**

Figure 11 shows two of the originating requirements for function “RFI from ISRD”. Note that each originating requirement traces to multiple functions and that the source of the requirement is documented.

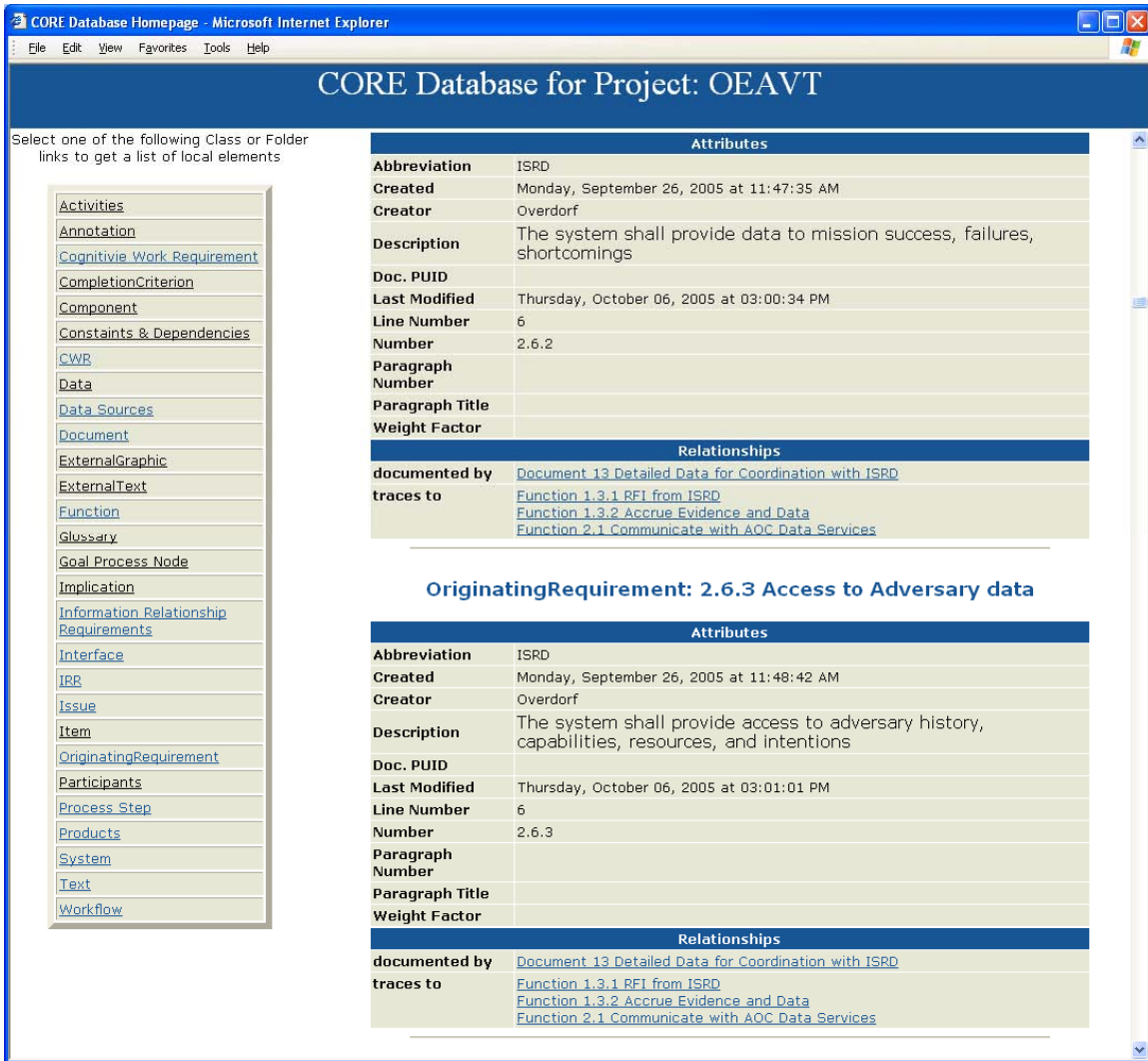

Figure 11: Example of Two OEA VT Requirements

## 9.5 Step 5: Scope Requirements

The final step in the process was scoping the requirements. The model created by the process included the OA tasks for all phases of a conflict. It was obvious, early on, that it would not be possible to support all of Operational Assessment with the OEA VT tool. Rather than decide, a-priori, what Operational Assessment tasks OEA VT would perform, it was decided to look at the tasks that OA needed to perform and assign the most relevant ones to OEA VT. The scoping task involved an examination of each of the OA functions and the associated originating requirements. The OEA VT team conducted internal reviews of the desired functionality, compared the desired functionality with the statement of work, and prioritized choices based on discussions with the OA SMEs. Candidate lists of requirements to eliminate were created. These lists were formally reviewed and iterated with the customer until a final list of

requirements was developed. The final list of requirements is documented in Appendix C. Note that the appendix includes all of the 334 original requirements and that a number of these requirements “generated” issues (CORE column name). The issues in the “generates” column document the disposition of the original requirement. A blank in the “generates” field, indicates that the requirement was accepted. Other issues include: “out of scope”, defective, and “potential” requirements. Requirements with these issues were ultimately rejected. Other “generates” issues resulted in changed, but ultimately accepted, requirements.

## 10. OEAVT SOFTWARE ARCHITECTURE

### 10.1 Software Engineering Overview

The OEAVT Software Engineering effort was a rigorous process conforming to the OEAVT Project Management Plan and executed in compliance with CMMI<sup>SM</sup> Level 3 processes. The OEAVT Software Implementation is to be used in Air Operations Center (AOC), targeting the Operational Assessment Team (OAT) as the principle user. From the outset, the OEAVT visualizations were designed as separable/stand-alone components subscribing to a common data model (using a publication/subscription mechanism) and communicating via anonymous controller events utilizing the Model-View-Controller (MVC) design pattern<sup>3</sup> (with particular emphasis on the Java implementation<sup>4</sup>).

The final instantiation of the OEAVT Software Implementation was the *System for Cognitive Visualization of Operational Assessment* (SCVOA). The SCVOA was a stand-alone application designed to demonstrate the OEAVT visualizations. The original goal of integration with AOC systems of record was not realized, primarily because of program direction decisions made outside of OEAVT and AFRL/RH. These included cancellation of the TBONE program and the decision to “fast track” other systems for fielding in the AOC. The SCVOA software design, however, has been optimized for interfacing with future AOC systems of record once they have been fielded.

The SCVOA incorporated most of the major assessment concepts envisaged during the investigatory phase of the project including elements of cognitive workflow. Central to the application workflow was the concept of perspectives. The notion of “perspectives<sup>5</sup>” in the generic sense is not new. However, the SCVOA was the first application we know of that implemented *assessment perspectives*. We used assessment perspectives to help manage cognitive workflow in the application.

The SCVOA has four defined perspectives: Action-Effect Contrast Visualization (AECV), Geo-spatial Visualization (GEV), Indicator Analysis Manager (IAM), and the Assessment Task Manager (ATM). Of the four perspectives, only the AECV perspective was fully implemented due to time and budget constraints. The GEV module was removed from OEAVT after the planning and assessment contractor development teams determined that it was redundant to a similar capability contained within the planning system. Again, this system could have utility in supporting some aspects of assessment, if the operational community decided that geo-spatial information was a desirable feature in an assessment support system. The other two perspectives were populated with static concepts.

---

3 Applications Programming in Smalltalk-80<sup>TM</sup>: How to use Model-View-Controller (MVC). Steve Burbeck, Ph.D, 1987, 1992. Online, University of Illinois at Urbana-Champaign. (12 Aug, 2008). <http://st-www.cs.uiuc.edu/users/smarch/st-docs/mvc.html>

4 Java BluePrints – J2EE Patterns. Sun Microsystems, Inc. Online. (12 Aug, 2008). <http://java.sun.com/blueprints/patterns/MVC-detailed.html>

5 Using Perspectives in the Eclipse UI. Object Technology International, Inc., 2001. Online, Eclipse.org. (13 Aug, 2008). <http://www.eclipse.org/articles/using-perspectives/PerspectiveArticle.html>

## 10.2 Software Components

The SCVOA is a pure Java implementation, making use of three open-source libraries (in the form of Java JAR files) in addition to the standard libraries available in the Java J2SE 1.4.2 environment. The three open-source libraries are:

- JFreeChart<sup>6</sup> (jcommon.jar, jfreechart.jar) – used to implement all bar charts (including the AECV itself) and the spider web plot.
- Apache Batik<sup>7</sup> (batik-awt-util.jar) – used to generate the gradient in the AECV.
- H2 Database<sup>8</sup> (h2.jar) – used to implement persistent data storage (used by the Persistent Data Store [PDS] package).

The SCVOA itself is comprised of four major Java packages as shown in Figure 12. The top-level package has the fully qualified name of “mil.af.afrl.hec.” Directly underneath the top-level package are the four primary software components:

1. mil.af.afrl.hec.aecv – contains all of the AECV-specific source modules
2. mil.af.afrl.hec.awm – contains all of the AWM-specific source modules
3. mil.af.afrl.hec.gev – contains all of the GEV-specific source modules (currently unimplemented).
4. mil.af.afrl.hec.scvoa – contains all of the SCVOA-specific source modules, including the “common” modules.

---

6 JfreeChart. Object Refinery Limited, 2005-2008. Online. (13 Aug, 2008). <http://www.jfree.org/jfreechart/>

7 Batik SVG Toolkit. The Apache Software Foundation, 2000-2008. Online. (13 Aug 2008). <http://xmlgraphics.apache.org/batik/>

8 H2 Database Engine. The H2 Group. Online. (13 Aug, 2008). <http://h2database.com/>

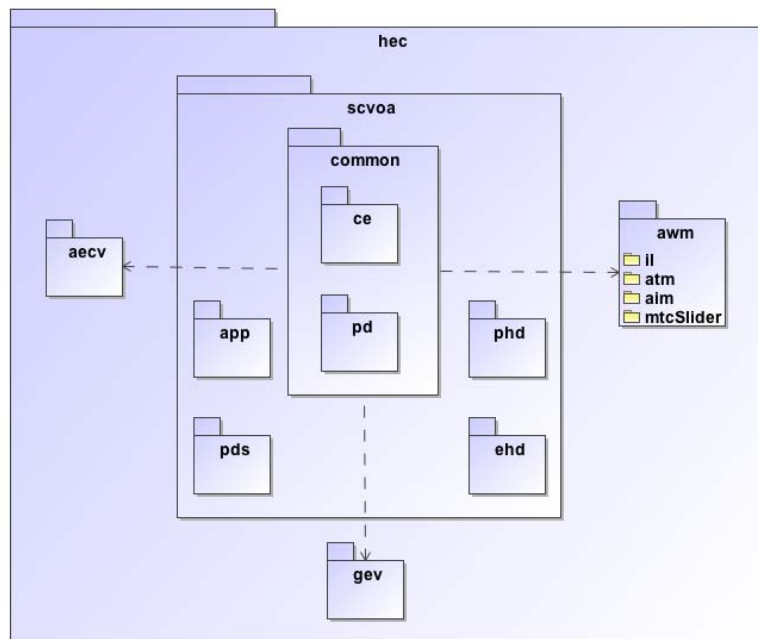

**Figure 12: SCVOA Package Overview**

The packages and modules in `mil.af.afrl.hec.scvoa.common` are “common” to all packages in the SCVOA (intimated by the dashed-lines in Figure 12). The SCVOA is explicitly designed to be separable at the package level. For example, the `aecv` package has no dependencies upon (i.e. does not require in order to compile or be instantiated) the `awm` package or the plan hierarchy display (`phd`) package. However, the `aecv`, `awm`, and `phd` packages depend upon the `scvoa.common` package.

The `scvoa.common` package contains all of the components of the data model. The `scvoa.common.ce` sub-package contains all of the classes and interfaces needed to support Controller Events. The `scvoa.common.pd` sub-package contains all of the classes and interfaces needed to support Persistent Data publication and subscription. These three packages are required by just about every component in the SCVOA.

### 10.3 SCVOA Application

The implementation of the SCVOA application itself can be found in the `scvoa.app` package. Due to its demonstrative nature, this package has dependencies upon all of the other packages. The application package encapsulates all of the user interface logic in the main window, including the `perspective` software implementation and the day controller.

### 10.3.1 Demonstration Mode

One of the unique features of the SCVOA is the ability to restart the application and initialize as if it were at a different point in time than “the current real time.” This facilitates demonstrations of the application by showing the assessment at one point in the conflict, then “fast-forwarding in time” to see how the assessment has changed later in the conflict.

This feature was implemented by engineering the application so that each scenario in the persistent data store (PDS) has a single absolute time reference for the start of the conflict (i.e., “D-0”). All other time references in the PDS are relative to D-0. By pushing D-0 back in time, the assessor effectively moves forward in simulated time. This is all handled quite transparently by the SCVOA.

### 10.3.2 Demonstration Data

As the data model solidified, it became clear that the SCVOA would require a significant amount of data in order to display something meaningful. Clearly this kind of data would be available in a real military conflict such as one the tool was designed for. The question was, “How do we demonstrate and test?”

To that end, we created an unclassified sample scenario with sufficiently detailed data to show both how the application works and why it is relevant. As a happy aside, it provided most of the conditions we required in order to perform acceptance testing.

Normally, the initial data for the system would be acquired via machine-to-machine interfaces from AOC systems of record. We were constrained by the need to have an unclassified data set. Rather than write an entire user interface for our data entry that would be superfluous in the real AOC environment, we chose to create the data using a spreadsheet and import the data as comma-separated value (CSV) files.

Attaining data consistency and coherence with a spreadsheet proved to be challenging. Initial inconsistencies were often revealed during the import process by a database constraint failure. Further data checks were added to the data import mechanism to enhance data entry validation. As the tool matured, the visualizations themselves proved to be of significant value in ferreting out the last data inconsistencies.

### 10.3.3 Plan Hierarchy Visualization

The *scvoa.phd* package (hereafter referred to as the “PHD”) encapsulates the Plan Hierarchy Visualization. This visualization is JTree implementation with Controller Event generation and Persistent Data Subscription to the Campaign Plan and Effects. The PHD is a good example of the minimal implementation needed for a functional SCVOA component.

### 10.3.4 Assessment Visualizations

All of the supporting assessment visualizations (except for the AECV itself) are encapsulated in the *mil.af.afrl.hec.awm* package. This includes:

- Effect Attribute Visualization
- Indicator Attribute Visualization
- Indicator List (including the IWPC eCAT Spider Diagram)
- Threshold Visualization
- Weight Visualization
- Multi-Thumb Color Slider

### 10.3.5 Value Model

The Value Model implementation can also be found in the *mil.af.afrl.hec.awm* package. The SCVOA implements the Value Model as its own thread, running on demand in response to a significant change in the data model. During first invocation, the Value Model traverses the entire Effect Hierarchy once, bringing all assessments up-to-date as needed. For large effect hierarchies, this initial assessment may take a perceptible amount of time.

The Value Model provides the assessor with a quantitative assessment of the effects-based plan. The following discussion summarizes the concepts.

Central to the Value Model is the comparison of effort expended with assessed effectiveness in the form of a truth table Figure 13.

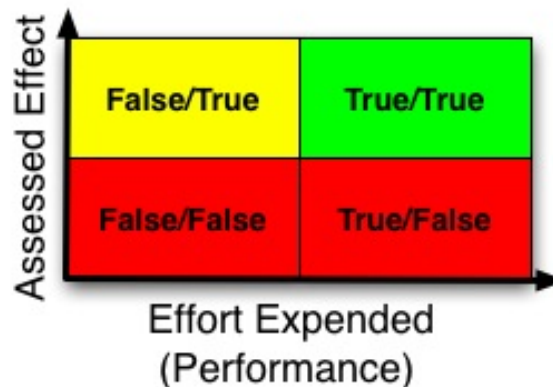

**Figure 13: Greathouse Truth Table**

As a "two-by-two" table, there are four conditions: two that are normal (i.e. they conform to expectations) and two that signal a condition requiring investigation. The conditions are expressed in the form of effort expended/effectiveness assessed. True and false suggest extreme limits in the existence of an effort expended and an effect to be assessed.

1. False/False – no effort expended, no assessed effect. This condition is to be expected and does not particularly merit additional investigation.
2. True/True - effort expended and a corresponding level of effectiveness is noted. This condition is also what the assessor expects and is not an indication of something amiss.
3. True/False – effort expended, but no assessed effectiveness. This condition requires further investigation into why the effect is not being achieved.
4. False/True – no effort expended, but a perceived effectiveness has been assessed. This also bears further investigation into the underlying data supporting the assessment. In this case, the apparent effectiveness is suspect until an explanation has been deduced.

Conversion of these two input conditions from boolean values to rational numbers allows an assessment to be quantified within a continuous assessment space.

However, a scale over which effort and effectiveness can be evaluated must be determined. The OEAVT team chose to quantify performance in terms of DMPI-Sortie-Equivalents (DSEs). (*For an explanation of DMPIs and DSEs as applied to kinetic planning and assessment, see AFTTO 3-3.AOC, 1 November 2007 FINAL, section 3.3.3.3*). A DSE table was built with assigned DSEs for specific combinations of delivery platform and ordnance. This document postulates ways to describe non-kinetic effort (e.g. refueling sorties, PsyOps, etc.) in terms of DSEs.

Assessed effectiveness is, in the end, a subjective evaluation of an effect based on established assessment criteria (Indicators) and the weight assigned to those criteria. The Value Model allows the assessor to transform that evaluation into a continuous assessment space with objective results in the form of the Value Model roll-up (see Figure 14 below).

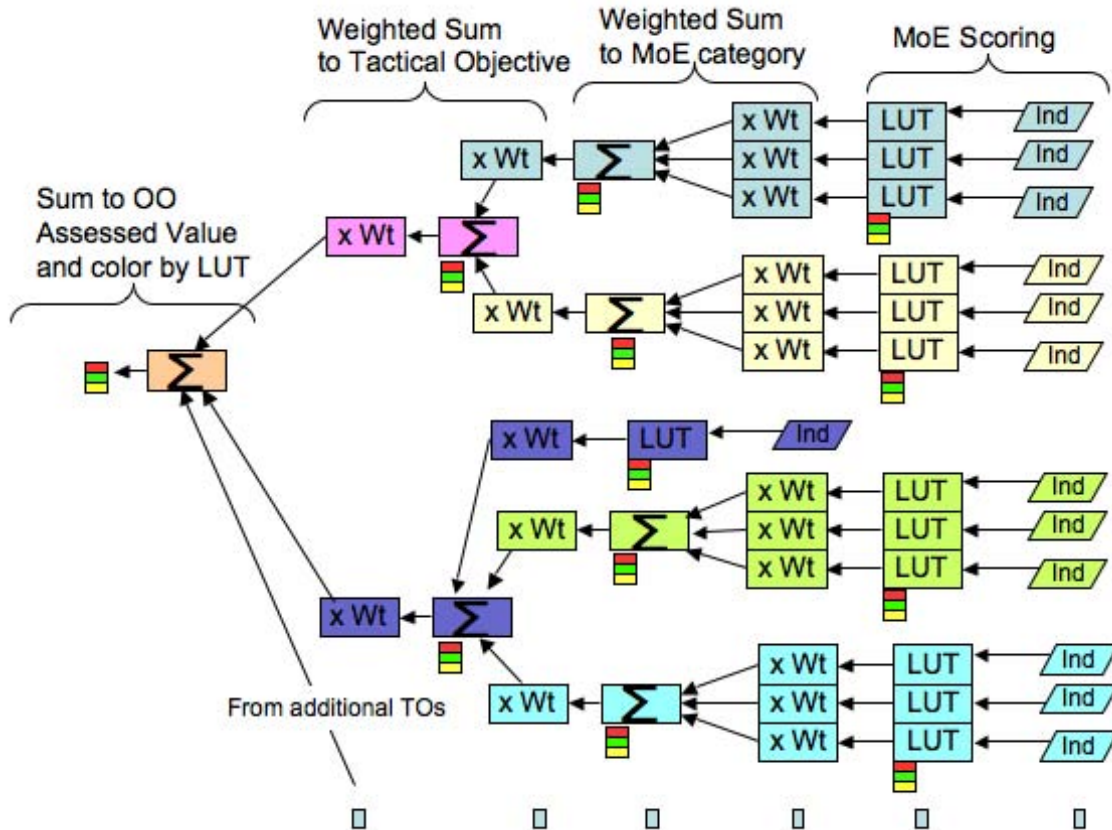

**Figure 14: Value Model Roll-up**

The primary calculation in the Value Model is a *summation of products*: weight times Indicator assessed effectiveness. An assumption of the Value Model is that all the weights in the calculation must add up to one (1). The OEAVT value model is a weighted mean, with the requirement that all of the weigh coefficients are positive and sum to one. (Note that this special case of a weighted mean with positive weight coefficients that sum to one is also known as a convex combination).

As the diagram shows, the Value Model is analogous to a tree in the sense that the leaves of the tree are the Indicators associated with the Tactical Tasks in the Campaign Plan. The Value Model calculation for Tactical Task assessed effectiveness is a simple summation of products for that Tactical Task's Indicators.

Continuing the tree analogy, the twigs in the tree are the rolled-up assessed values of the Tactical Tasks. In this analogy, the Tactical Objectives would be the small branches in the tree. The roll-up for the Tactical Objectives is complicated by the fact that a Tactical Objective may (and probably will) have associated Indicators in addition to its child Tactical Tasks. The Value Model must take into account both (Indicators and Tactical Tasks) in the roll-up calculation for the Tactical Objective.

The weights of the associated Indicators *and* the child Tactical Tasks must add up to one (1). The Operational Objectives (the major branches in the tree) roll-up in the same manner as the Tactical Objectives, taking into account both their own Indicators and their child Tactical Objectives.

The assessor is responsible for updating or adding new Indicator values based on new tactical/operational information and adjusting the weights as the dynamics of the conflict change.

## **11. OEAVT System Components**

Four major components were developed for the OEAVT system during the life of the program. Not all of these components reside in the current version of the system. One challenge that the development team had throughout the life of the program was the dynamic nature of the operational environment. This led to changing requirements and, in some cases, re-directions based on program decisions at the ACC level.

One example of this was the development, and subsequent discarding, of the (TI3). Development was begun when it seemed increasingly clear that TBMCS would be replaced with TBONE. The TI3 was then put into development in order to acquire the strike results from TBONE that would be needed to “feed” the AECV. When the TBONE effort was subsequently cancelled the TI3 component was discarded, although this module could still be extremely valuable in supporting the OAT’s need to acquire strike results for purposes of assessment.

Another development was the assessment visualizations for the Global Effects Matrix-Synchronization (GEM-S). This effort was to improve initial visualization concepts developed by personnel of the Joint Information Operations Warfare Center (JIOWC).

### **11.1 Action–Effect Contrast Visualization**

#### **11.1.1 Purpose**

The AECV system is the centerpiece of OEAVT. It supports the two primary functions of Operational Assessment. These are the assessments of progress toward desired effects; and the management and evaluation of indicators, evidence and tactical assessments upon which Operational Assessments are based. These functions stood at the top of an operational requirements hierarchy that emerged during the early portions of the program from operational documents, research documents, observations of field operations and interviews with assessment SMEs. Previous analyses of the assessment environment also reinforced the existence of these functions as two of the three crucial aspects of successful assessment. Based on the operational, cognitive and system analyses carried out in early project stages, the OEAVT team decomposed these two high-level functions into several component functions. This decomposition formed the basis for the development of the system requirements upon which specific capabilities would be developed. Each is briefly introduced below in the section on Current Status.

### 11.1.2 Development Process

The AECV was an outgrowth of a general work domain and cognitive analysis of Operational Assessment carried out in the initial stages of the OEAVT program. These analyses were themselves, refinements of analyses of the Strategy Division carried out in Phase I of the RH for AOC program. The Phase I analyses were carried out by ManTech Corporation and focused on activities carried out across the entire Strategy Division. Accordingly, the analyses carried under the OEAVT program focused more exclusively on the operational and behavioral activities carried out by the Operational Assessment Team in support of Operational Assessment. The analyses we conducted were assessment-wide, that is; information bearing on all aspects of assessment, from pre-execution assessment planning through post-execution archival activities, was collected and analyzed. As part of our systems analysis, the OEAVT team then selected a subset of this characterization of assessment for further development. The AECV was the centerpiece of that development.

The analyses carried out by the OEAVT team relied on 3 primary data sources. The first was existing documentation about operational and cognitive work aspects of Operational Assessment. The team reviewed material in this category including instructional materials, AFTTP materials, operational manuals, publications and papers presented at conferences and scholarly papers addressing the subject of assessment (theses, dissertations and so on). A second information source included attendance at exercises in which assessment played a prominent role and at workshops and other meetings involving the strategy planning and assessment communities within the Air Force. At these events we had a chance to interview operational personnel, observe operational and work processes relevant to assessment, and engage in informal discussions of various aspects of assessment. The third information source consisted of detailed and ongoing interactions with our own SMEs and other expert members of the Air Force planning and assessment community. All of our activities with all of these information sources were focused on characterizing the process of Operational Assessment from three points of view: an operational view, a work view and a behavioral view. These three views, captured in both the concept maps and the subsequent system model, are crucial and equally important facets of a successful system of visualization support. As shown in Appendix A, the constituents of these views included operational processes and activities, requirements, preconditions and contingencies, products and data (in the case of operational views); systems and interfaces, task hierarchies, organizational considerations, and artifacts (in the case of work views); and processes and cognitive work elements, information, critical decisions, goals and strategies (in the case of behavioral views).

This information was used by the OEAVT team to carry out system analysis following the work domain and cognitive engineering analyses and to develop the system model for assessment that followed the initial system analysis. It was during this initial system engineering analysis that the team defined the boundaries of the system for subsequent development. That is, the initial cognitive engineering analysis defined assessment. The subsequent system engineering analysis defined what aspects of assessment the system would support. When the boundaries of the OEAVT system had been identified, the team then developed the system model. The portions of the concept maps and critical decision analyses that were relevant to the in-scope system to be

developed served as the baseline documents for system model definition. System model development was led by the project system engineer. However, the model itself was developed by a team consisting of the lead system engineer, analysts that had conducted the cognitive engineering analysis, and the project SMEs. This ensured that the system model contained the information needed to generate valid requirements while also containing important information from the work and cognitive analyses. This step was critical, as system model development often is done solely as an engineering analysis. This can result in a failure to include crucial cognitive and work considerations in the system requirements. The system model developed for the overall OEAVT system is shown in Appendix B.

The system model was used to generate overall system requirements. These are shown in Appendix C. The OEAVT team used the system requirements to identify major areas of capability. These areas were aggregated into the subsystems of the visualization tool. In general, our analysis indicated that assessment consisted of four major activities: Planning activities, the actual process of assessment, indicator and work management, and post assessment activities. We chose to base development on assessment processes and indicator/work management based on our analyses and interviews with operational assessors. In the next section we briefly summarize its major elements and features as currently configured.

### **11.1.3 Current Status and Capability**

The AECV supports effects assessment by permitting the assessor to contrast current air campaign status with planned progress, scaled simultaneously against effort and effectiveness in a defined value space. These contrasts can be applied to elements at all levels of an effects-based plan. The AECV also supports management and evaluation of indicators and evidence by providing configuration access to this information at any point during the assessment process. Assessors can define new indicators, adjust the confidence associated with indicators, and view indicator data sources and historical information for any selected plan element.

The AECV is organized into three primary work areas, as shown in Figure 15. The progress visualization pane contains the primary information upon which ongoing Operational Assessment is based. This pane contains information about planned and actual progress of the air campaign, presented as both a summary snapshot and dynamic trend information. The navigation/indicator pane contains controls that allow assessors to navigate and configure the AECV and to explore and manage indicator information for the plan elements shown in the progress visualization pane. The configuration pane, shown at the bottom of Figure 15, allows assessors to develop and edit indicator specifications, add new indicators, edit indicator text and enter justifications for assessment decisions. Each pane will now be discussed in more detail.

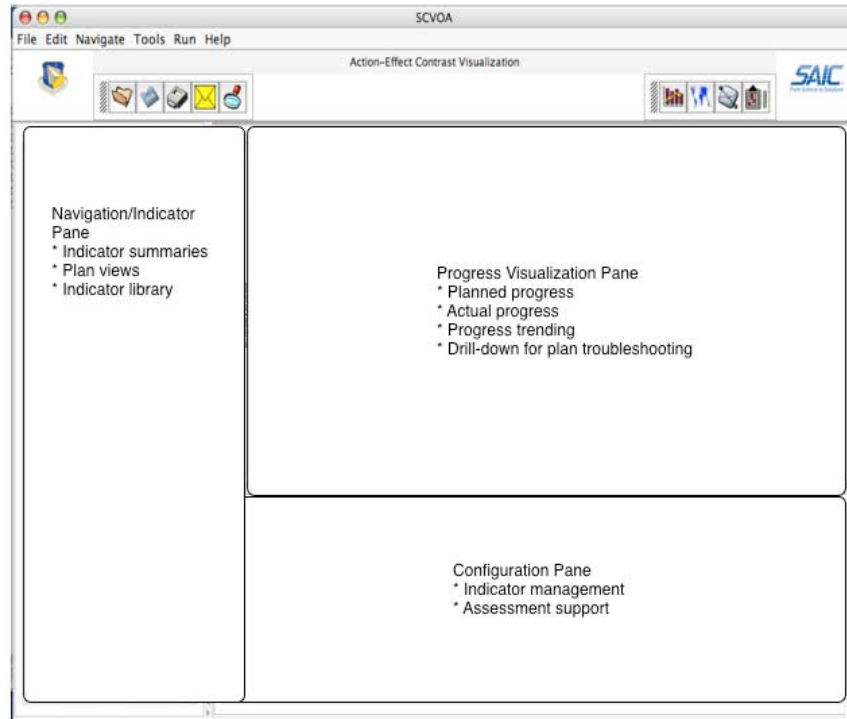

**Figure 15: The AECV Supports Assessment Through the Use of Three Panes**

The AECV progress visualization pane presents two alternative views for assessment support: a Summary View and a Trend View. In the Summary View, multiple effects, rendered as operational objectives, are plotted on a single AECV gradient representing the selected day (as selected by the Day Controller). A summary view gradient is shown in Figure 16.

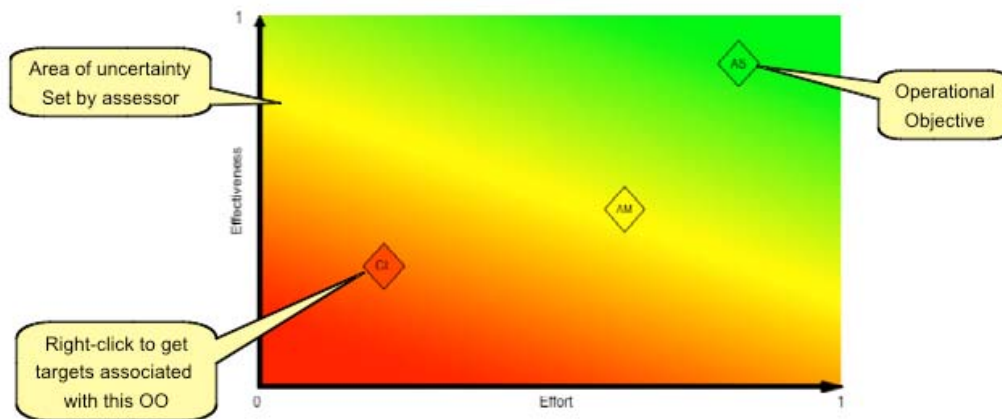

**Figure 16: AECV Summary View**

In the Trend View, multiple gradients are rendered with trend lines plotted to represent both assessed effectiveness and planned effectiveness. Figure 17 shows a trend view example.

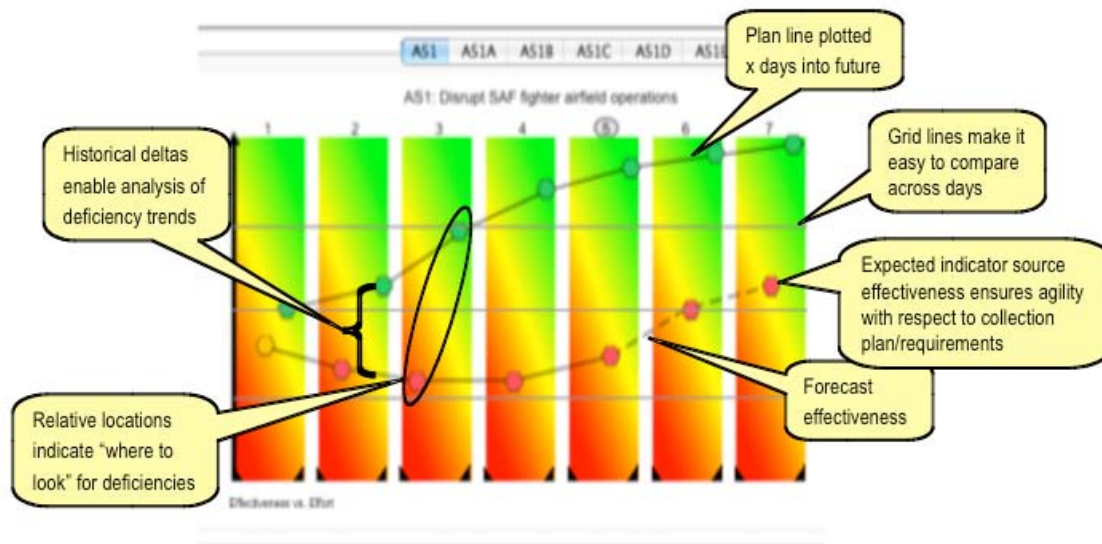

**Figure 17: AECV Trend View**

Each panel gradient of the trend view is a compressed version of the gradient shown in the summary view, compressed to the unit of time (hour, day, month, etc.) chosen by the assessor. Panels contain the same two dimensions of effort and effectiveness that are contained in the summary view as well as the three adjustable areas of certainty as shown in the summary view. Each panel can be adjusted in width. Two points are contained in each panel. One point represents the planned effort/effectiveness for the time unit chosen. This point will always be placed to the far right edge of each panel, as one always expects to expend all effort that is planned. The location of the point vertically will be a function of expected effectiveness for the time period in question. The second point represents the actual effort/effectiveness for the time period of interest. The placement of this point will vary in both the horizontal (effort) and vertical (effectiveness) dimensions as a function of actual air campaign results. Both points are color-coded to indicate the confidence associated with their placement. Obviously, the points representing planned effort/effectiveness will always be coded green. The actual point can vary from red, through yellow, to green. The distance between the points indicates “deviation from plan.” Points are connected with lines across time gradients, thereby showing a trending of effort and effectiveness across the time increments chosen by the assessor.

The AECV addresses several specific areas of assessment within these two broad categories. The system allows assessors to load a range of OA plans developed in other applications, such as MS Excel, for use in assessment. This allows the assessment team maximum flexibility in developing assessment plans according to the methodologies unique to their operating environments.

Once an OA plan is loaded assessors can configure the AECV progress visualization pane by setting the values of the assessment gradient, defining the number of panels in the trend assessment display, defining the units of assessment (months, days, hours). A summary gradient or a set of trend panels for a plan element of the assessor's choice can be displayed.

Contrasting actual progress at specific points during the air campaign to planned progress plotted out at the beginning of the campaign is one of the central responsibilities of the OA team. It is crucial that assessors be able to see this progress (or lack of progress) (1) at a glance (2) with some indication of the confidence that they can place in the displayed progress, (3) with some indication of the direction in which progress is trending, and (4) with information that provides insight into how best to troubleshoot problematic areas. Members of the OA team contrast actual to planned progress toward effects by comparing trend lines representing these two indices on the work pane portion of the AECV. The trend lines are overlaid on a gradient describing a value space in dimensions of effort and effectiveness. This four-valued space is rendered as a continuous gradient extending from green (low effort – high effectiveness), through yellow, to red (high effort – low effectiveness). Each trend-line anchor is rendered in one of three colors to indicate the confidence in the assessment i.e., in the placement of the anchor on each unit gradient. These colors are red (low confidence), yellow (guarded confidence) and green (high confidence). The placement of these trend lines, anchored to each unit gradient, across an assessor-selected period of time provides the OA team with at-a-glance indications of progress toward effects, with confidence estimates attached to these contrasts. The plan element displayed provides assessors with the information needed to quickly target troubleshooting activities if progress seems to be non-existent or trending downward.

Assessments of progress toward effects have little meaning without accompanying estimates of confidence. The OEAVT system provides two types of confidence estimates. In the first type, confidence in the progress toward effects is shown as variations in the colors of trend line anchors in the progress visualization pane. This was summarized above. The second type of confidence estimate applies to indicator performance and is shown in the navigation/indicator panel. The confidence in each indicator will be shown as a small block under the indicator text containing one of three letter codes for low (L), moderate (M) and high (H) confidence. These blocks also are color coded, as shown in Figure 18. The confidence associated with indicators can be set manually in the configuration pane. The top portion of the indicator summary contains a configurable display that provides at-a-glance updates of the performance of each indicator for a plan element of interest. This display is both location and color-coded. Each individual indicator is shown in separate panels under the configurable display. Each panel contains the indicator text, the plan element to which the indicator “belongs,” confidence estimates for the indicator, a configurable diagram summarizing the performance of data used to index the indicator, and indicator values as defined in the OA plan.

It also is important for the OA team to be able to predict the effectiveness associated with plan elements. This is accomplished in the progress visualization pane by extending the prediction trend line across gradients associated with future assessment units. For example, as shown in Figure 18, a predicted plan line might extend 3 days into the future. The anchor points of these expected trend lines will always be placed at the maximum of the effort scale, since one expects that all planned effort will be expended. Anchor placement in the effectiveness dimension will be a function of the predicted effectiveness for the unit in question.

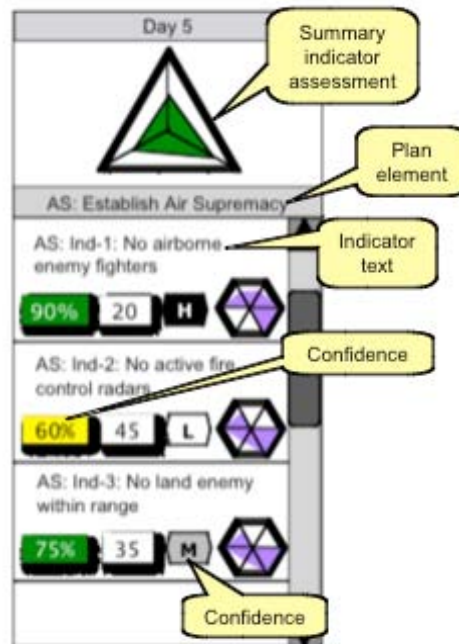

**Figure 18: Indicator Confidence Values are Shown as Coded Blocks Under Indicator Text**

The management of indicators is of almost equal importance to the actual assessments. An Operational Assessment is invalid if it is based on the “wrong” indicators or if the “right” indicators are not configured in a way that they provide a meaningful context for assessments. Effective indicator management, then, consists of two co-equal parts: defining a diagnostically coherent set of indicators for the plan elements defined by the plans team and dynamically configuring the indicator set so that assessments are interpreted in ways that can provide near-optimal information to the plans team and JFACC. The OEAVT system supports these two goals through the configuration panel. The configuration panel is used to define indicators for each plan element; assign values and weights, or edit these, for each indicator; set confidence zones associated with air campaign results; edit indicator data sources; and adjust plan element value status. The design of these AECV indicator management components benefited greatly from analyses and concept development carried out by the ManTech Cognitive Systems Engineering Center (CSEC), under sub-contract to SAIC.

Figure 19 shows the configuration panel for specifying indicators and their weights. As indicators are fed into the AECV from the value model they are added to the indicator panel shown in Figure 19. Their weights then can be dynamically specified as the air campaign evolves by moving the pointers on the adjustment bar shown at the right of Figure 19. Weights can be locked for particular indicators by clicking the lock symbol to the right of each indicator text.

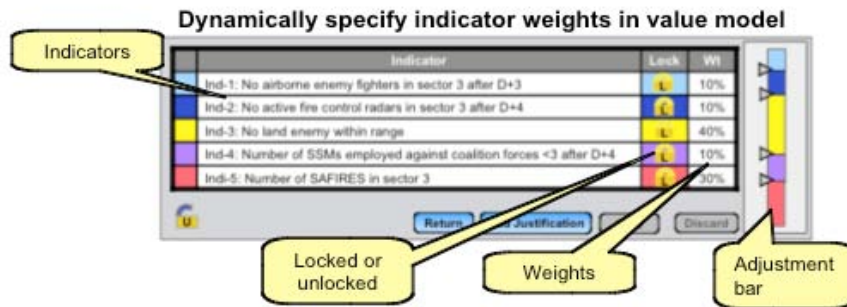

**Figure 19: Panel Used to Edit Indicators and Weights**

Confidence zones for each plan element can be set with the confidence zone editor shown in Figure 20. Based on information associated with each indicator in the value model, confidence zones will be set that reflect assessor judgments of the points at which results indexed by that indicator pass from unfavorable, through cautionary, to favorable outcomes. Assessors can edit these values dynamically simply by moving the boundary pointers to a new, desired location on the confidence bar.

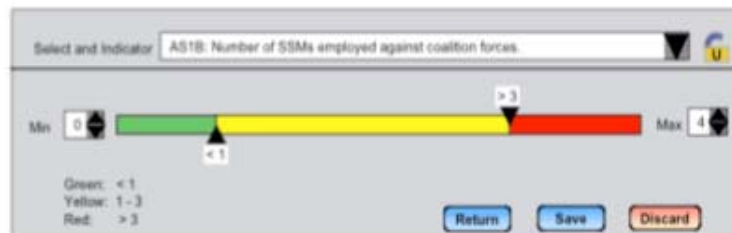

**Figure 20: Confidence Zone Editor**

Indicator data sources also can be edited, as shown by Figure 21. For each indicator, shown at the top of the display against a yellow background, there will be several data sources that collectively contribute to the evaluation of the indicator. These data sources are updated as new results become available, allowing assessors to inspect them dynamically as the air campaign unfolds. The source of each report is shown to the left of the report text, and will include each of the normal intelligence sources. Confidence is shown next to each source. The time of the report also is shown to the right of the report itself. Using this panel, assessors can page through the sources for each indicator by selecting a desired indicator with the drop-down indicator selector. Indicator weight, value and confidence can each be edited through the use of the panel to the right of the indicator text.

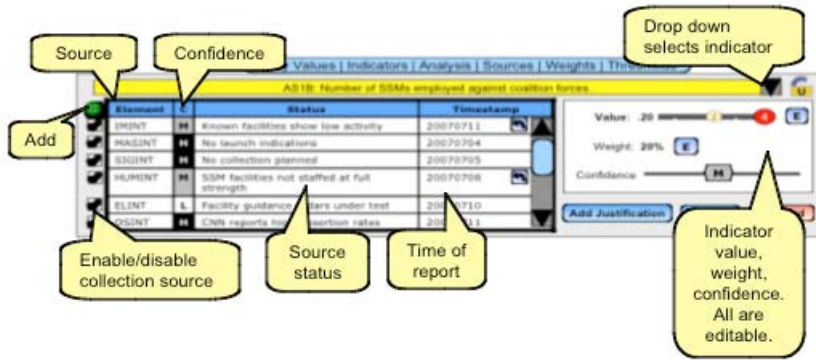

**Figure 21: Indicator Data Sources**

Assessors can edit plan elements dynamically by using the plan element value status panel, shown in Figure 22. This panel is both a status panel and an editing panel. The status portion of the panel is shown on the left side of Figure 22. This area displays a daily summary of the plan element of interest for both the effectiveness and effort dimensions. Planned values in each of these dimensions are shown as blue histogram elements, with the plan value printed inside the histogram. Actual values are shown immediately below, again as histograms with values printed inside. This allows both an at-a-glance comparative evaluation of progress toward accomplishment of the plan element as well as a more analytical evaluation (if so desired) based on the digital values. This is in keeping with a general principle of visualization design: Support quick, effortless (analogical) evaluations of progress through at-a-glance visual “thinking” along with more effortful, analytical (digital) inspection or exploration, if needed or desired. The right side of the plan element value status panel allows assessors to edit plan element weights and confidence so as to keep them aligned with the evolution of the air campaign. When this information is changed, assessors will typically be required to provide some justification for the changes. This is supported with the addition of a justification block under the editing panel.

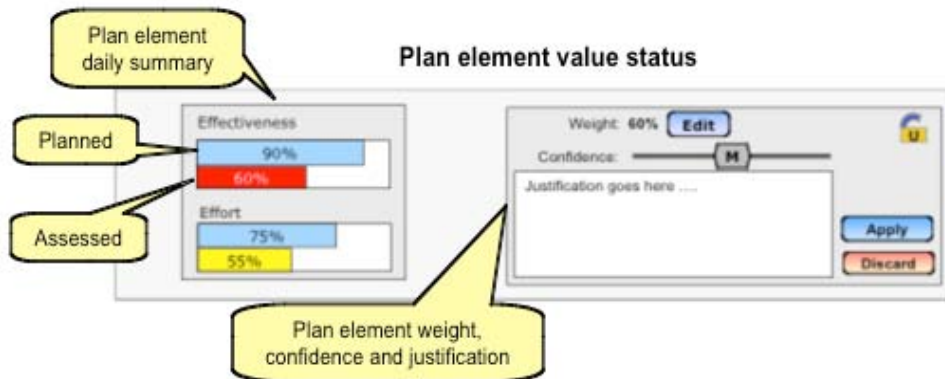

**Figure 22: Plan Element Value Status**

When results deviate from the plan, it will be necessary for the OA team to “troubleshoot” the air campaign. All three panes in the AECV are used to successfully carry out this troubleshooting. The progress visualization pane is used to detect the presence of a deviation between planned and actual progress. Additionally, assessors use this pane to determine the general area of the plan in which the problem exists. That is, is the deviation from plan at the operational objective level, the tactical objective level or the tactical task level? The progress visualization pane supports this exploration by allowing the assessor to search hierarchically through plan elements, inspecting deviations from each element in the hierarchy. This hierarchical search is shown in Figure 23.

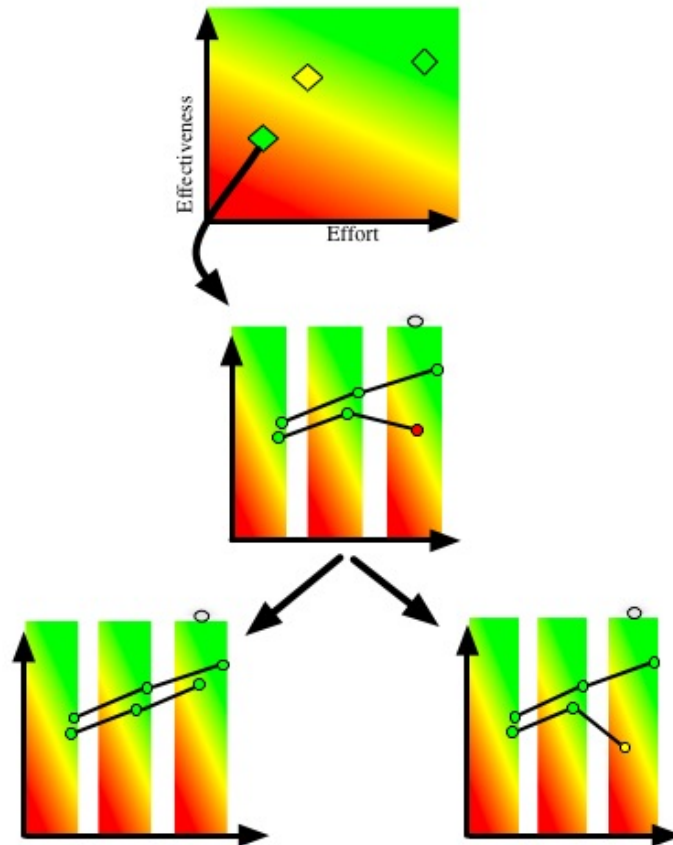

**Figure 23: Hierarchical Search Through Plan Elements**

The top-level summary display shows an operational objective in the red area, indicating lack of progress toward effects. Its green code indicates high confidence in the lack of progress. The assessor then drills down to one of the tactical objectives (TO) in an effort to locate the reasons for the lack of progress. This is shown in the middle display. Here we can see that there is a discrepancy between planned and actual progress in the third panel. The assessor then drills down further to some of the tactical tasks for that TO, finding the problem with tactical task CL1B. Specific corrective action then can be recommended. Alternatively, the assessor might make adjustments to the value model, the indicators or the data upon which the indicators are

based in order to tune the dynamic assessment plan. By searching in increasing detail from top-level summary to individual operational objectives, and then selectively down through tactical objectives to tactical tasks, assessors can pinpoint the sources of plan deviations. They then can inspect individual and groups of indicators associated with the focal plan element to determine the “causes” of plan deviations.

A pervasive aspect of Operational Assessment is the need to manage uncertainty. The uncertainty inherent in Operational Assessment arises from several sources including measurement uncertainty associated with selection and implementation of indicators, the uncertainty associated with the accuracy and timeliness of results during ongoing air operations, uncertainty arising from the combining of individual assessments into aggregate assessments (often referred to as assessment roll-ups), and uncertainty arising from indicator specifications (that is, is this indicator specified in a way that is meaningful to the needs of the assessment?). The OEAVT system implements several means of addressing uncertainty in Operational Assessment. In terms of infrastructure the system is designed to provide reporting of strike results as they become available, thereby minimizing uncertainty due to timeliness. Uncertainty due to indicator measurement accuracy is addressed by allowing assessors to define and dynamically reset the confidence associated with each indicator. The uncertainty that can arise from initial definition of indicators, carried out during OA planning, can be addressed through the use of an archival indicator library that contains features such as intelligent search, system suggestions regarding indicators that have been useful in past operations of a similar nature and so on. Although this library was not implemented in the current version of OEAVT, design concepts were developed and have been included in archival documentation contained in the appendices. Uncertainty also arises in connection with the type of operation being undertaken and with the methodology in use for assessment. Some types of operations (e.g., traditional kinetic operations) will tend to be “less uncertain” than other types (e.g., peacekeeping or humanitarian operations). In the former example both the indicators and the assessment methodologies tend to be more familiar, more “trustworthy,” more easily understood and interpreted by assessors. This is less so in the latter examples. Thus, an effective assessment support system should allow assessors to express this “contextual uncertainty.” The OEAVT system accomplished this through the use of a configurable gradient, allowing assessors to define regions of uncertainty as well as positive and negative certainty for each of the plan elements contributing to overall Operational Assessment. This gradient allows assessors to, in effect; visualize their impression of the risk associated with the operation under assessment. The last source of uncertainty that the OEAVT system addressed was that of effort/effectiveness ratios. Both of these dimensions are important to a complete assessment. It is not, however, acceptable to consider them in isolation. Rather, individual plan element assessments should allow at-a-glance understanding of deviations in both dimensions. The OEAVT system accomplished this requirement by presenting trend lines varying in both effort and effectiveness dimensions simultaneously.

In summary, the AECV component of the OEAVT provides the capability to create the visualizations which aid the assessor in determining if the desired operational effects are being achieved during the execution of the battle plan. The OEAVT system software, (allows the assessor) to assess the level to which desired operational objectives are being achieved by determining the extent to which planned actions are achieving planned/desired effects. The

software system provides the Assessor with at-a-glance insight into:

- Air operations progress, sources and causes of plan deviations
- Analysis capability to enable effective development of recommendations to Air Component Commanders
- Assess progress toward operational objectives by reference to the overall plan element
- Assess progress toward tactical objectives
- Actual and expected progress, and finally,
- Identify new opportunities for actions or effects

While AECV and the OEAVT system software provides discrete quantitative assessment data, its strength lies in how it draws the assessor's attention to areas in the strategic plan that are relevant in terms of assessment.

## **11.2 Geo-spatial Effects Visualization (GEV)**

### **11.2.1 Purpose**

The Geo-spatial Effects Visualization (GEV) was proposed to address the shortcoming of bar graphs and spotlight charts in portraying assessments in geo-spatial context. The GEV sought to preserve the simplicity of spotlight assessment colors assigned to indicators placed in geo-spatial context. This map display provided understanding not only of the assessment results, but the adequacy of the assessment model in geo-spatial terms: Were indicators being sampled in critical corridors? Did assessed effects, when plotted spatially, suggest new avenues to strike at an adversaries center-of-gravity? The GEV display was intended to provide at-a-glance presentation of information to address such questions.

### **11.2.2 GEV Development**

An initial whitepaper was written and presented to 711 HPW/RHCP that detailed the reasons why Geo-spatial Effect Visualization is necessary in effect assessment, listed the data sources required to implement the capability, and suggested approaches for implementation. (Geo-spatial Effects Visualization (GEV) - A White Paper For Air Force Research Laboratories / Human Effectiveness).

An internal study was conducted on the human perception of symbols on maps, with an emphasis of understanding overlays on depictions of terrain, lines of communication, and political boundaries. The guidelines resulting from this effort were documented in, *OEAVT Concept Design Principles: Map Displays*, 27 January 2006, which is attached as Appendix D.

The application of some of these design principles can be seen in an Adobe Photoshop® mockup of a GEV display, depicted in Figure 24. The following display characteristics are used:

- Stoplight colors based on the CIE-LAB color space designed to allow legibility of overlay text.
- Shaded terrain relief and unsaturated colors in the base map graphic to enhance legibility of overlays.
- A later GEV concept, using transparency to indicate the “weight” of an indicator, thus showing the importance of the red indicator relative to the other indicators by the intensity of its surrounding “halo”.

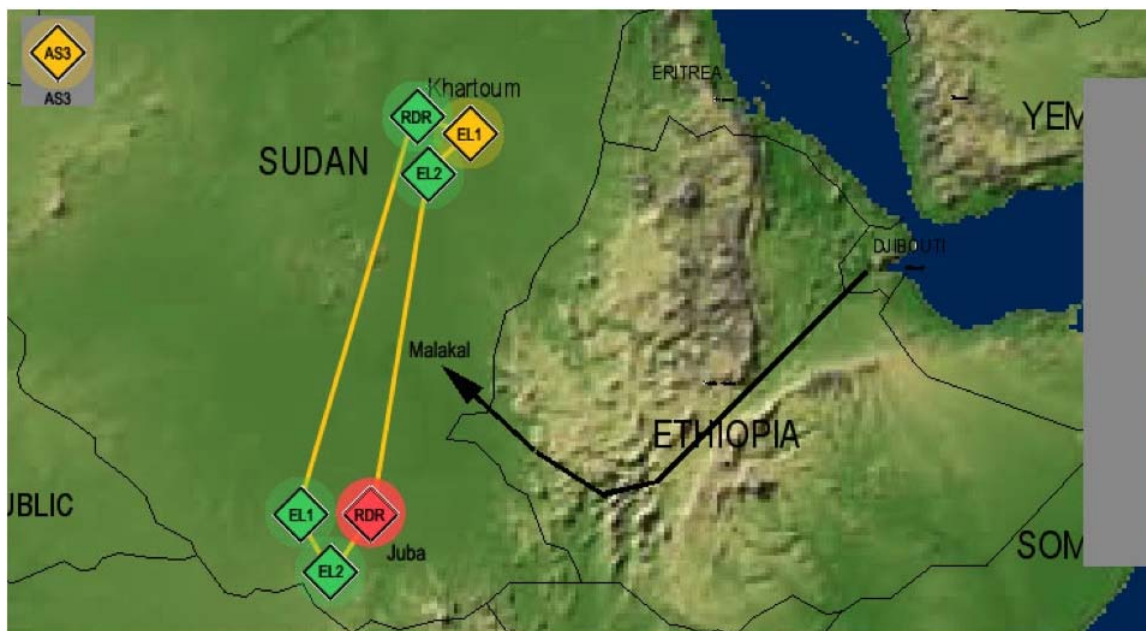

**Figure 24: GEV Photoshop mockup**

A Trade Study was conducted to ascertain the functional capabilities of several candidate mapping applications against notional functional requirements (Appendix D). Candidates reviewed included OpenMap, ArcGIS, OSSim, Google Earth Basic and Pro, Google Maps, JView, and uDig. From this trade study, OpenMap was selected as the mapping tool to be utilized in initial GEV design and prototyping. OpenMap’s main benefits were: It is open source, and it has a full API, fully configurable from GUI layout to data handling for each layer. It’s only real detraction was that it is solely a 2D mapping library. But there were no plans to add any 3D capabilities in the first design.

An initial design was created around the OpenMap library. OpenMap is layer based, and so the GEV was designed around a layer/overlay architecture. Initial layers were a Base Layer

containing by use selection either rendered DTED data or CADRГ imagery. Overlaid on the base layer would be one or more PMESSI layers—Political, Military, Economic, Social, Infrastructure, and Information. The initial design would focus on basics like city and state names, roads, utilities. The top overlays would consist of the effect assessments.

A GUI Conceptual design was created, as depicted in Figure 25 below.

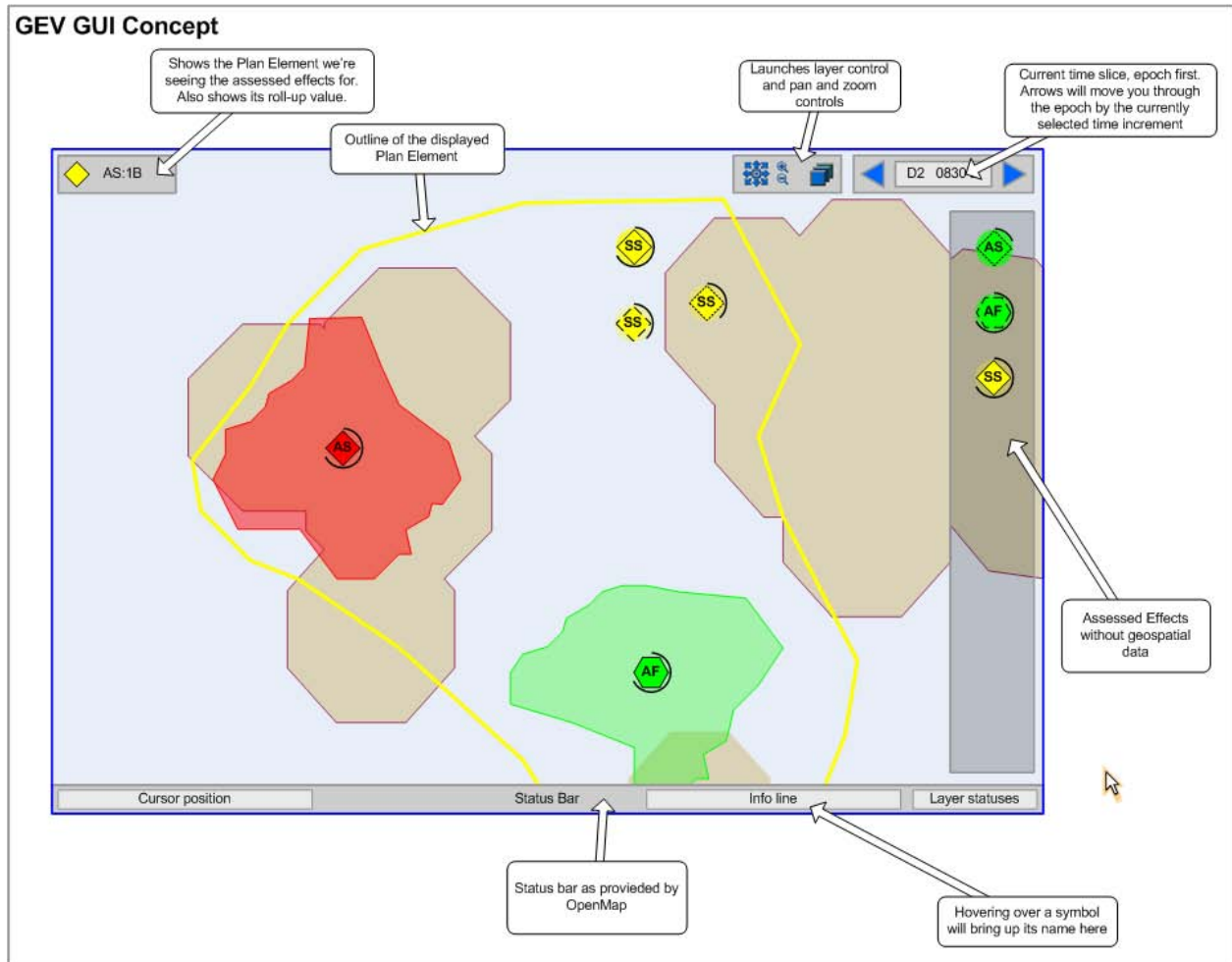

**Figure 25: GEV GUI Concept**

From that, OpenMap was used to create a set of design mockups. (Appendix D). The core of the design was the visualization of effects by an area of effect that would be colored per stoplight status (Green, Yellow, Red), with a solid outline. The area for a given element would be generated from aggregating child plan element locations, or at the lowest level, target locations. Plan element type would be shown through the use of icons. The icons are also colored per stoplight status, and the area around the icon would be filled with a level of transparency correlating to the weight of that plan element’s assessment. Figure 26 depicts the basic design mockup in schematic form, showing the map area, assessment summary symbol, geographic and non-geographic assessment symbols, and a basic toolbar:

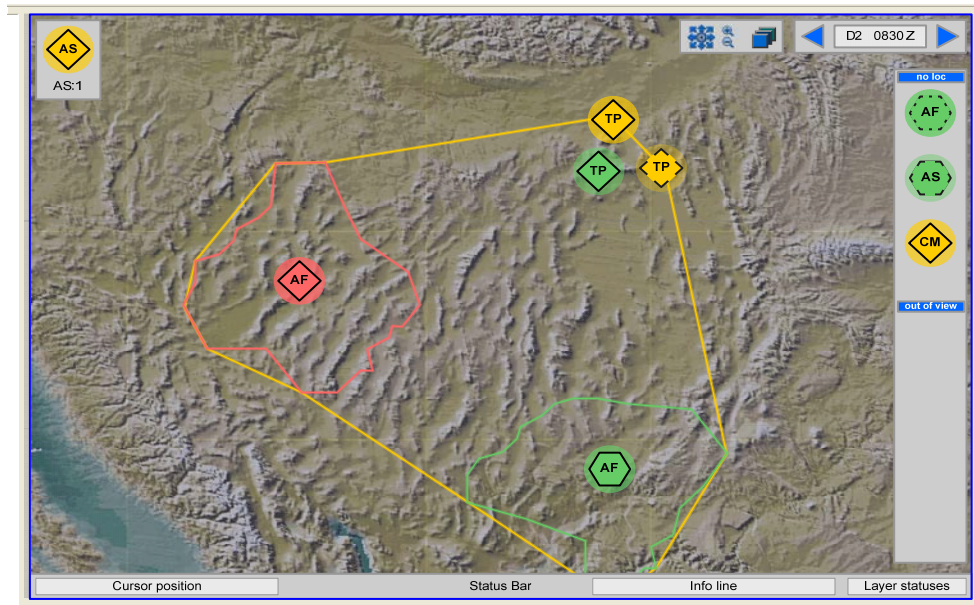

**Figure 26: GEV schematic design mockup rendered in OpenMap**

### 11.2.3 Current Status and Future Development

Due to budgetary constraints, further development of geo-spatial effects was put on hold in June, 2007. The design and remaining issues were documented in OEAVT Geo-spatial Effects Visualization (GEV) Software Design Notes, July 2, 2007, previously delivered to 711 HPW/RHCP.

## 11.3 TBONE-IWPC Indicator Interface (TI3)

### 11.3.1 Purpose

The TBONE-IWPC Indicator Interface (TI3) was conceived as a proof-of-concept machine-to-machine integration between IWPC and TBONE. Its intent was to capture information residing in the TBONE strike results database and make it available to the IWPC assessment component (the Enhanced Causal Analysis Tool (eCAT) module), thereby making visible to the OAT information bearing on Operational Assessment. Under this vision, TI3 was officially designated as the “Indicator Support System” within the IWPC development community.

From its conception, the intent was for TI3 to be a simple, low-impact augmentation to eCAT. To realize this intent, and in keeping with program desires and engineering constraints articulated by the primary IWPC integrator (General Dynamics), SAIC isolated the TI3 integration code into a separate module accessible from eCAT. This kept any required changes to eCAT at a minimum.

### 11.3.2 Development

The genesis for TI3 arose during a Strategy and Assessment (S&A) Requirements Sub-Working Group (RWSG) Technical Exchange Meeting (TIM) held in March, 2005. This TIM was held to investigate data requirements for TBONE. A consideration of Operational Assessment during this meeting indicated that a need existed to make tactical strike results available to IWPC, the Operational Assessment system of record. The OEAVT team was tasked to develop a solution that would accomplish this integration.

Upon approval by the IWPC integrator of the TI3 system engineering plan, SAIC began prototyping a concept for enabling search and display of TBONE strike results and other assessment-relevant data in eCAT. The first milestone was a simple proof-of-concept search capability that would allow analysts to access TBONE data services, located on TBMCS DevNet, in order to acquire tactical information to support Operational Assessment.

The centerpiece of this capability was the TBONE Data Surf Board (TBDSB). The key to the surf board is the TBONE MetaData, which would allow us to pre-populate a set of drop-down boxes with data that were implicitly accurate for that instance of TBONE (since it was based on the meta-data). For the first iteration of the TBDSB, we derived our metadata using Java introspection of the TBONE DataObjectSet class. This helper application allows developers to construct and execute TBONE ad hoc queries without having to re-write the program. The team developed a TBDSB GUI and successfully loaded a hand-built TAS Object (the base class WebTAS object in the TBONE data model). In the mean time, we experimented with a rote TBONE counter (TBDC) that did nothing more than traverse the TBONE meta-data and return counts of all the object instances in TBONE, thereby creating a phase 1 working version of the TBDSB that allowed simple queries to be made.

In parallel with phase 1 TBDSB development, SAIC proceeded with initial modifications to eCAT. In keeping with the engineering constraint of "minimal changes to eCAT," SAIC implemented a single change to the eCAT GUI in the form of an additional button (circled in Figure 27).

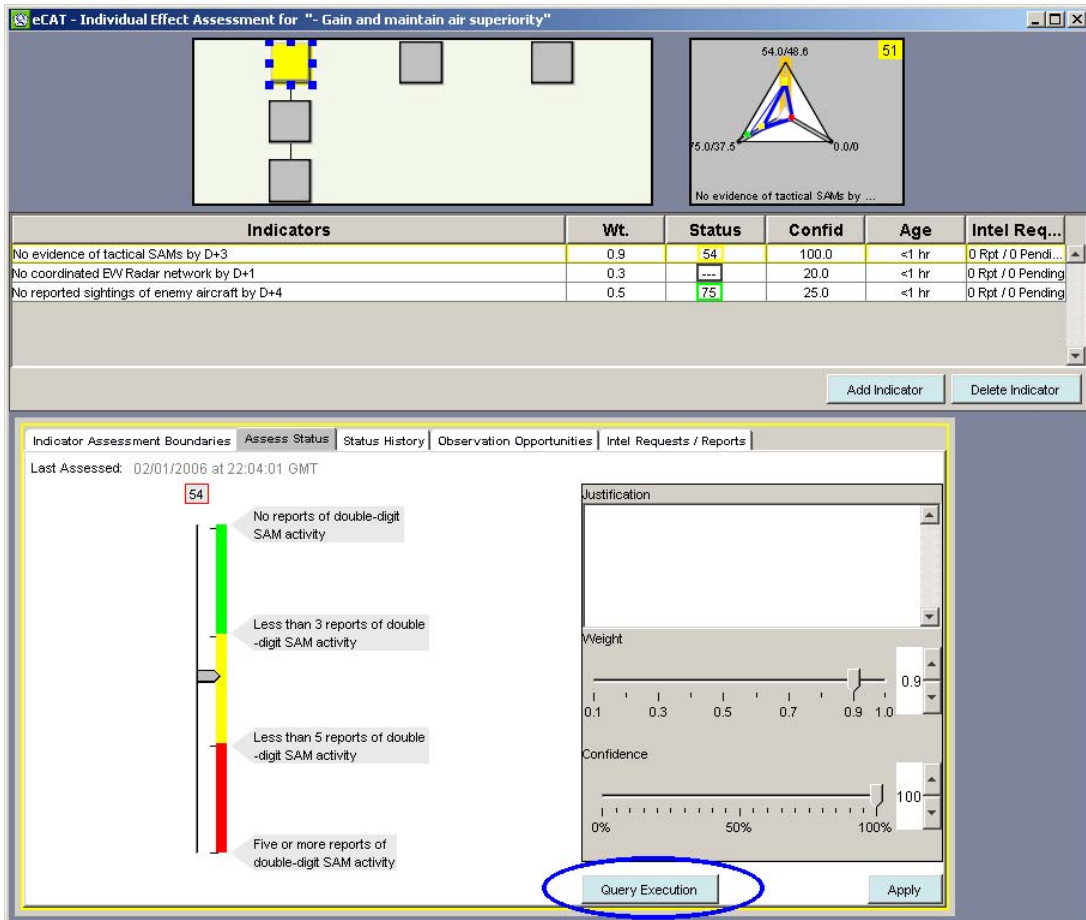

**Figure 27: TI3 Modification to eCAT GUI**

The second version of the TBDSB made direct use of meta-data available in TBONE rather than using Java introspection. This reliance on TBONE meta-data greatly improved the stability of the surf board. Assessment data within the TBONE data model were associated with TBONE strike results, as shown in Figure 28. In order to access this information, assessors entered queries based on elements of the effects-based plan and indicators associated with those plan elements. This information was then drawn from the TBONE tactical strike results database. The results were provided to assessors through a TI3 interface integrated into the eCAT module of IWPC.

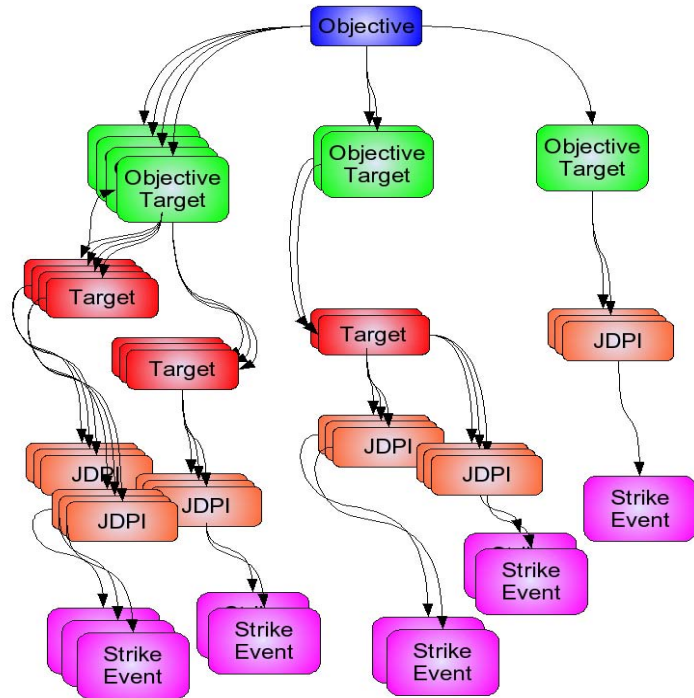

**Figure 28: TBONE Assessment Data Chain**

Concurrent with the second phase of TBDSB development, SAIC developed a pop-up window for integration into IWPC that would have the proper IWPC look-and-feel and interact correctly with the rest of the IWPC windows (i.e. close when the parent window closed, etc.). The resulting concept of operations for the TI3 is represented in Figure 29.

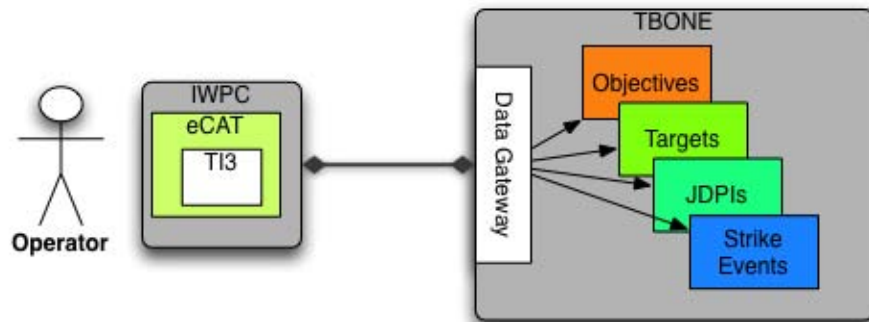

**Figure 29: TI3 ConOps**

### 11.3.3 Current Status

The TI3 is invoked from inside eCAT by clicking the "Query Execution" button on the eCAT "Assess Status" screen (Figure 27). This action will display the TI3 "Indicator Assessment" pop-up window, initialized with query parameters based on the current Effect and Indicator selected in eCAT (Figure 30).

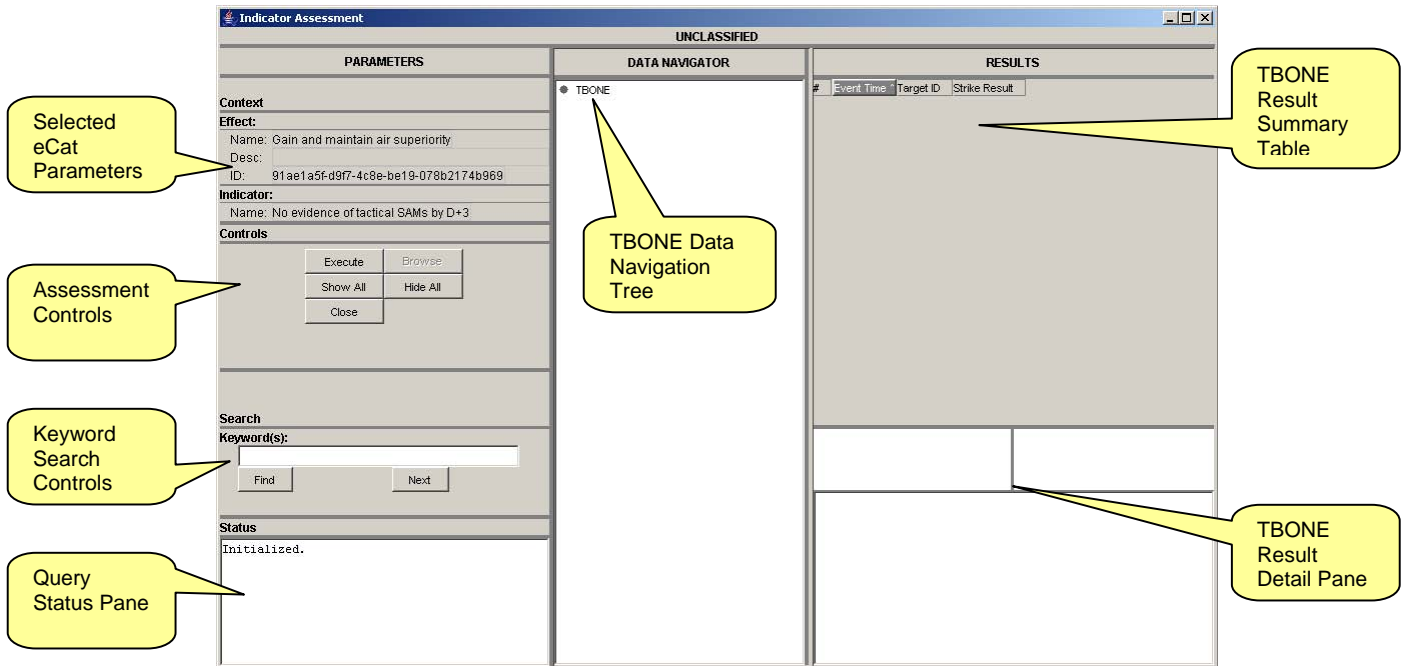

**Figure 30: TI3 Indicator Assessment Initial Screen**

The assessor clicks the "Execute" button (middle-left) to initiate the TBONE query. The "Data Navigator" pane (center) is then populated in real time as assessment data are retrieved from TBONE. Assessors are free to peruse results while queries are in progress. When a query is complete, the "Status Window" (lower-left) will indicate "Query finished."

Selecting a result line in the Results table will reveal the details of that Strike Request in the pane below the table.

The Indicator Assessment window can be switched between two display formats. The first format is keyword search mode (Figure 31), allowing the assessor to perform an automated search for one or more keywords. In this format, matching results are highlighted in the "Results" area and the corresponding data element is highlighted in the target tree displayed in the Data Navigator panel. The Result table scrolls as needed to reveal the highlighted search text.

The screenshot displays the Indicator Assessment application window, titled "Indicator Assessment" and "UNCLASSIFIED". The interface is divided into several panels:

- PARAMETERS:** Contains "Context" (Name: Gain and maintain air superiority, Desc: [blank], ID: 91ae1a5f-d9f7-4c8e-be19-078b2174b969), "Indicator" (Name: No evidence of tactical SAMs by D+3), and "Controls" (Execute, Browse, Show All, Hide All, Close buttons).
- DATA NAVIGATOR:** A tree view showing a hierarchy of targets under "TBONE". The selected target is "JDPI: PARKLING RAMP TEST 5" under "Target: MORONI HAHAI A AIRFIELD".
- RESULTS:** A table listing search results with columns for #, Target ID, Event Time, and Strike Result. The selected result is #15, Target ID A0602L, Event Time 12/23/2005 14:35, and Strike Result "Television station was heavily damaged, tower r...".
- Search:** A panel with "Keyword(s): television, market" and "Find" and "Next" buttons.
- Status:** A panel showing query progress: "query in progress ...", "Objectives found: 1", "Targets found: 8", "JDPIs found: 20", "Strike Events found: 20", "Query finished.", and "Found 'Television'".

Below the results table, there is a detailed view for the selected target:

Location: 113201S 0431619E	Target: A0602L
Time: 12/23/2005 14:35	Status Before: Operational
JDPI: PARKLING RAMP TEST 5	Status After: Repairable

Television station was heavily damaged, tower remains intact and presumably operational.

Figure 31: TI3 Keyword Search Format

The second format is browse mode (Figure 32), which maximizes the view of the results while hiding the parameter panel, the keyword search panel, and the status window. Assessors can switch back to keyword search format by clicking the "Return" button at the top-left of this display.

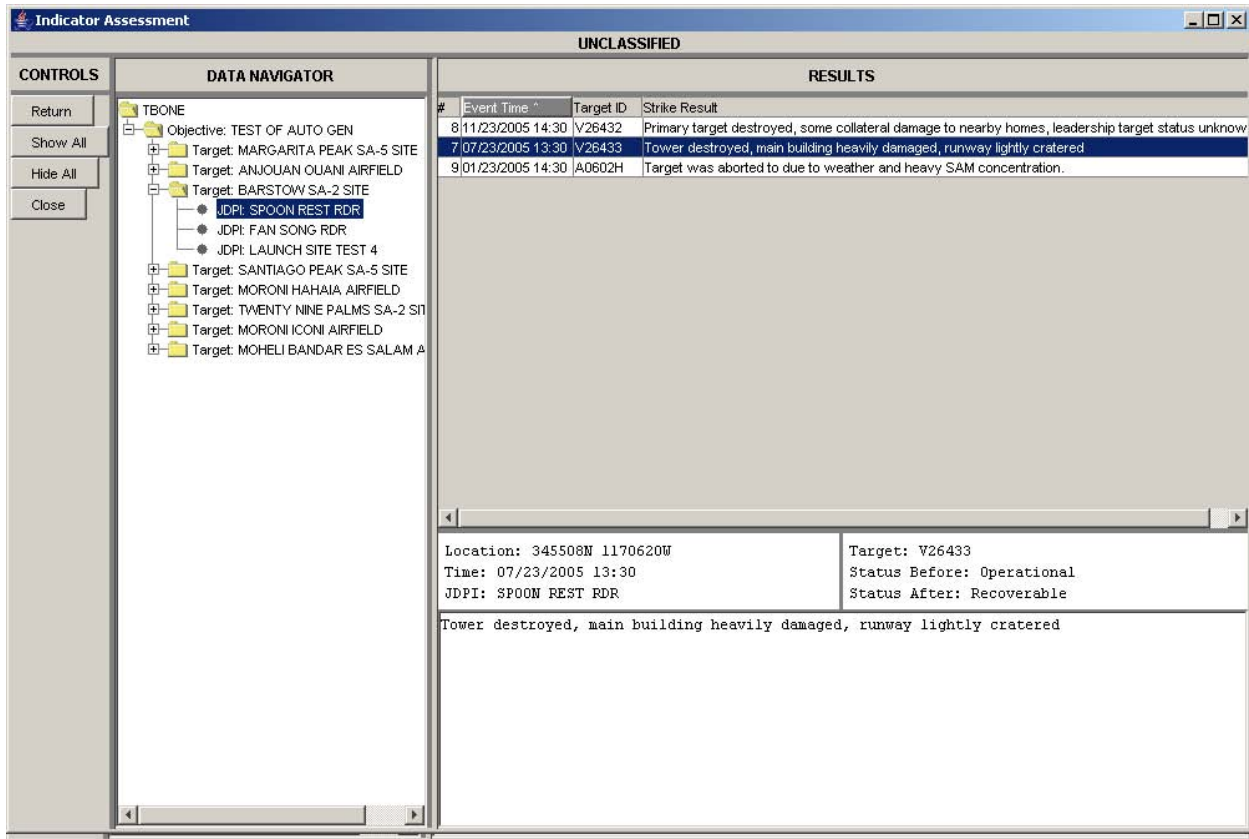

**Figure 32: TI3 Browse Format**

In April of 2007, the TBMCS Program Office officially cancelled TBMCS 1.1.4, including the TBONE development effort. This, in effect, also cancelled the TI3 effort. Thus, even though the capability was included in the SQT version of IWPC, the OEAVT team ended active development of the module at that point.

## 11.4 Global Effects Matrix-Synchronization (GEM-S) IO Assessment Visualization Design and Prototype

### 11.4.1 Purpose

This initial concept, further described in the following section, identified Influence Operation (IFO) activities accomplished by multiple organizations, and while recognizing the need for assessment, did not provide any visualizations for assessments. The Joint Forces Command (JFCOM) subsequently funded an SRA International effort to adopt the AFRL/RHC Course of Action (COA) Sketch tool to GEM-S needs, with SAIC contributing Information Operations (IO) assessment visualization concepts.

## 11.4.2 GEM-S Assessment Development

Development of the GEM-S Assessment Visualization Prototype was a short-term effort to address a lack of Influence Operations (IFO) assessment visualizations to support broad-ranging, national-level IO goals for the JIOWC). This effort originated at an Air Force Research Laboratory (AFRL) workshop where SAIC’s Operational Effect Assessment Visualization Technology (OEAVT) tools for visualizing the assessment of effects-based air operations were demonstrated to JFCOM personnel.

An initial elicitation trip to the GEM-S customer, the Joint Information Operations Warfare Center (JIOWC), introduced the broad scope of IFO activities, and the need for visualizing and assessing the various IFO activities associated with this plan. Classified topics were discussed in the elicitation, which are not further described. A spreadsheet-based visualization called the GEM-S had been constructed by the JIOWC/J24. This initial implementation of GEM-S, also known as the “horse blanket,” mapped national IFO objectives to a Primary Effects List (PEL), and in turn to an activity performed by a U.S. Government (DoD, State or other agency) or non-U.S. government activity. The status of the activity was color-coded to indicate active, planned, or needed. In this manner, the color code cells of the spreadsheet provided a rapid view of who was doing/planning what (at the level of program title), versus the objectives of the NIP. A column labeled “assessment,” mapped to objectives, was blank.

An unclassified surrogate of the “horse blanket” is depicted in Figure 33, and summarizes the basic elements of the synchronization matrix using a fictitious example of introducing electric vehicles to the U.S.

**Figure 33: Unclassified surrogate for the GEM-s “Horse Blanket”**

A second, unclassified elicitation session was held 19 December 2007 at SRA’s San Antonio facilities, and covered specifically the topic of IFO assessment. SAIC presented a small set of slides describing an IFO assessment concept, and received constructive feedback on IFO assessment.

The assessment visualization concepts for IFO presented during the second elicitation focused on characterizing the achieved effect of an IFO activity in terms of perception of the delivered message (direction) and penetration of the message in the target population (magnitude). Figure 34 provides an example graphic from that elicitation. The concept of magnitude versus direction was well received, and SAIC proceeded with further development of this concept.

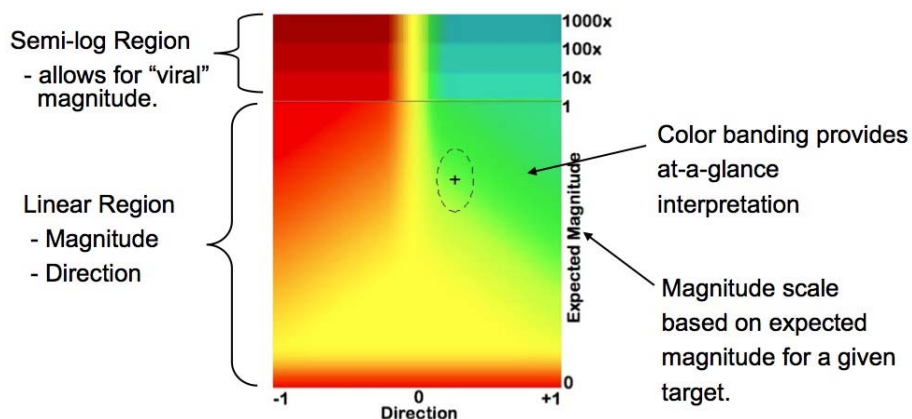

**Figure 34: Initial IFO assessment concept graphic presented to JIOWC**

No attempt to plot achieved effect versus expended effort was made due to the difficulty in uniformly quantifying effort across the activity domain of the GEM-S. Unlike kinetic air operations, where effort is fairly uniformly measured in Desired Mean Point of Impact (DMPI) – Sortie – Equivalents (DSEs), no uniform measure of IFO effort is known to exist. (*For an explanation of DMPIs and DSEs as applied to kinetic planning and assessment, see AFTTO 3-3.AOC, 1 November 2007 FINAL, section 3.3.3.3*).

A final, informal elicitation was conducted at the JIOWC, during the installation of the GEM-S/COA Sketch prototype. Classified topics were discussed along with the general nature of IFO assessment. A foreign media analyst and IFO assessor confirmed the utility of the direction/magnitude assessment paradigm and also provided samples of typical raw input provided to IFO assessors by commercial foreign media analyst, highlighting the need to refer to files in addition to operator provided comments in justifying assessments. Additional discussions were conducted on IO operations other than IFO. Jamming an adversary’s transmitter is an example of such an operation. Currently, the results of such operations are assessed on a “4-D” basis (i.e., Disrupt, Deny, Damage, Destroy), which can be thought of in terms of increasing duration and degree of effect on a target system. This discussion prompted the inclusion of what we will describe, for lack of a general term, as an “active” IO display, as opposed to IFO, in the prototype assessment tool.

### 11.4.3 Current Status and Future Development

The Prototype Assessment Visualization Tool was designed to support proof-of-concept demonstration to users for the purpose of refining and improving IO assessment displays. As such, it is not designed as a stand-alone tool, but as a visualization “engine,” which relies on an external system (COA Sketch) for Operational Plan inputs and underlying database. The prototype assessment visualization has been integrated to utilize the current COA Sketch database and API, and delivered to SRA International.

The original concept graphics were revised based on internal peer-review and IO SME review to depict two different basic assessment displays: one for IFO, and a second for “active” IO. These are depicted in Figure 35 and Figure 36 respectively. The functional capability and visual specification for the interface is described in greater detail in Appendix E.

Note that no interface is provided to manipulate the IO plan: this is created outside this tool in COA Sketch and imported for display. Controls are available to set:

- 1) Assessment values associated with IFO direction
- 2) Assessment values associated with IFO magnitude
- 3) Assessment values for duration for both desired and collateral indicators for active IO.
- 4) Assessment values for percent reduction in capability for both desired and collateral indicators for active IO.
- 5) Confidence for all indicators, both IFO and active IO.
- 6) Weights for all indicators and subordinate operations.



Figure 35: Basic IFO Assessment Display, with a Direction/magnitude Grid

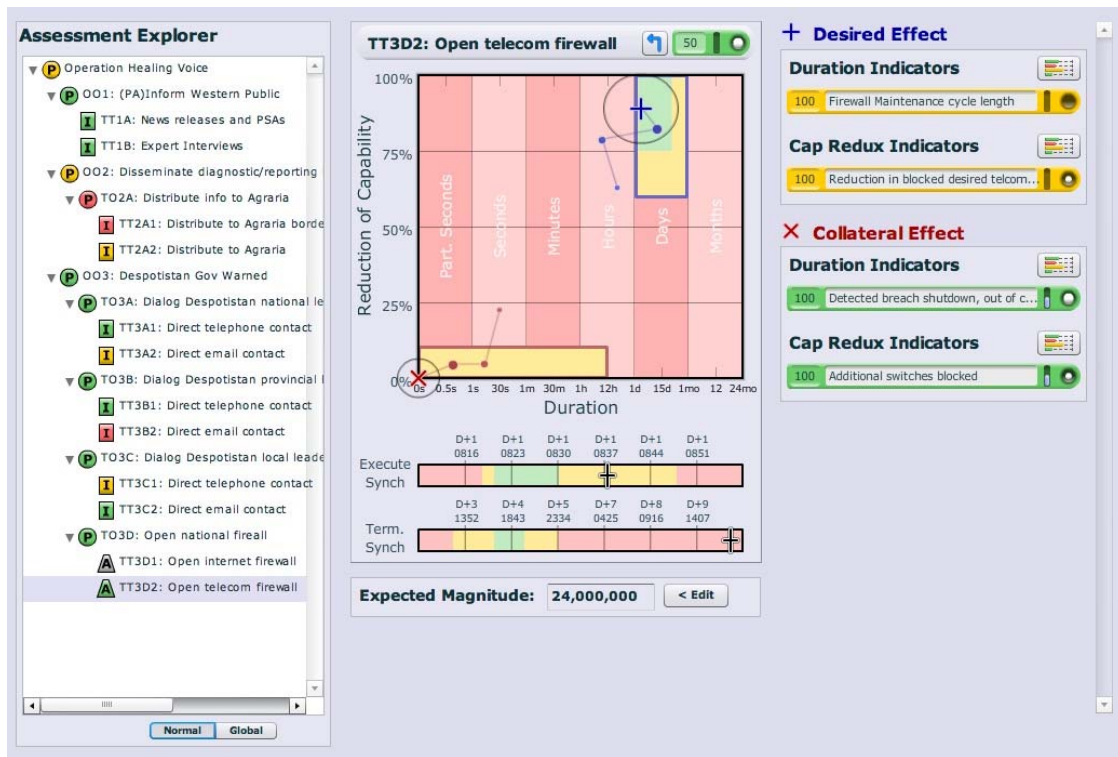

**Figure 36: Active IO Assessment Display, with a Duration/degree Capacity Reduction Graph**

The prototype assessment tool was evaluated internally by a mix of human factor engineers and by IO SMEs currently supporting the JIOWC and familiar with the IO assessment process. Overall findings were quite positive, with several general comments on good features:

- 1) The direction/magnitude display for IFO makes sense and is intuitive to understand.
- 2) The “active” display is also intuitive to understand and allows rapid characterization of the success of planned operations.
- 3) Supporting the mix/match of indicators and subordinate operations is flexible and supports real-world needs.
- 4) Controls and displays for assessed values, confidence, weights, and age are clear to understand and easy to use.
- 5) After an initial walkthrough, experienced IO assessors found the overall tool intuitive to use.

To support the evaluation, a fictional IO scenario was constructed, “Operation Healing Voice,” and an XML file was built to provide an assessment snapshot of this operation. This allowed SMEs and engineers performing the evaluation to see how the tool worked in context with an operation. Several areas for potential future improvement were identified in this process, and are discussed below:

1. Implement a capability to allow assessment of performance/effort.
2. Provide help reference to IO TTPs.
3. Provide mechanism for operator to define the indicator sampling technique.
4. Allow for review of justification history.
5. Display multiple collateral damage effects on the active IO display.
6. Improve the Operator Interface.
7. Alter the depiction of active IO desired or collateral effects to ovals.
8. Provide a detailed “analyst’s view” toggle for the active IO display to include point & click editing of effects bounds.
9. Provide a stand-alone capability; including local Op/effect input screens and database.
10. Allow expected magnitude to be set by indicator, rather than by effect.

Implement a capability to allow assessment of performance/effort. Current EBO doctrine calls for establishing both Measures of Performance (MoPs), and Measures of Effectiveness (MoEs). The prototype tool focuses exclusively on MoEs and their indicators. As discussed earlier, this design decision was based on the observation that performance (i.e., effort), especially for IFO, is difficult to measure in a uniform, repeatable fashion. Displays can certainly be added to evaluate MoPs, but the fundamental issue of uniform measurement must be addressed at the level of IO Tactics, Techniques and Procedures (TTP), in order to allow a meaningful comparison either within or between IO operations. This will require significant SME input, and subsequent acceptance by the IO community.

Provide help reference to IO TTPs. Within the realm of effects, the criteria for evaluating effects based on indicators follows TTPs (business process rules), that range from global to operation specific. Recognizing that assessors will vary in background and skill, and that the assessment of IFO in particular is subjective, help screens or windows that allow the operator to review these process rules in context to setting assessment values, confidences, and weights would aid in maintaining consistent assessments.

Provide mechanism for operator to define the indicator sampling technique. Equally important to assessment as selecting a measurable indicator is specifying the sampling method to be used. No provision currently exists for in COA Sketch or the assessment tool prototype to specify sampling method for an indicator. A related issue is the generation of an Assessment Information Request (AIR) needed to task collection assets under the tactical control of other commands to generate the data needed to satisfy the sampling method.

There is also an opportunity to apply statistical theory as a quality control measure to the sampling method. By describing the stochastic nature of an indicator and the sampling method and frequency applied, it is possible to predict the confidence yielded by a given sampling technique. This is currently a standard procedure in opinion polling, but is not routinely applied to other sample gathering techniques such as employing Intelligence, Surveillance, and Reconnaissance Division (ISR/D) assets. This can be used to determine if a given indicator is being sufficiently sampled, and just as useful, when it is being over-sampled and squandering a scarce collection asset. This metric does not address whether an indicator is appropriate or useful, but only that it is being sufficiently sampled to reach a given level of statistical confidence.

Allow for review of justification history. As currently implemented, the Assessment Tool requires that a user enter text or attach documents to justify each change in assessment, but provides no ability to review past justifications. Such review is essential to allow an analyst to review trend data. Suggested functionality includes:

- Scroll backwards in time through assessment justifications, showing each justification or attached file in chronological order.
- Provide symbols on the assessment display to show the approximate position of the displayed justification on the assessment trend-line.
- Display the actual date of the justification.
- Update the displayed indicator values (weight, assessed value, color) consistent with the point in time, and provide an indication of which indicator's justification is being displayed.

A concept for the history review interface is shown in Figure 37. Note that this should be a modal display: The user may review the history of indicator changes, but cannot adjust indicator values or alter roll-up assessments while in this mode.

Display multiple collateral damage effects on the active IO display. Based on user feedback, multiple collateral effects may result from IO actions. The most significant effects, not just a single effect, should be viewed on the Active IO display. To avoid rarely used complexity, it is suggested that the maximum number of collateral effects displayed for a single IO task be three. This does not mean that the user may only choose three collateral effects. Multiple indicators may be assigned and weighted to allow a sum of minor effects to be displayed as a single summary effect. In fact, with the display limit of three, a useful convention may be to display the two most significant collateral effects, and a summary for remaining minor effects. The presence of multiple effects requires that a weighting scheme be implemented to summarize collateral effects for the purpose of roll-up.

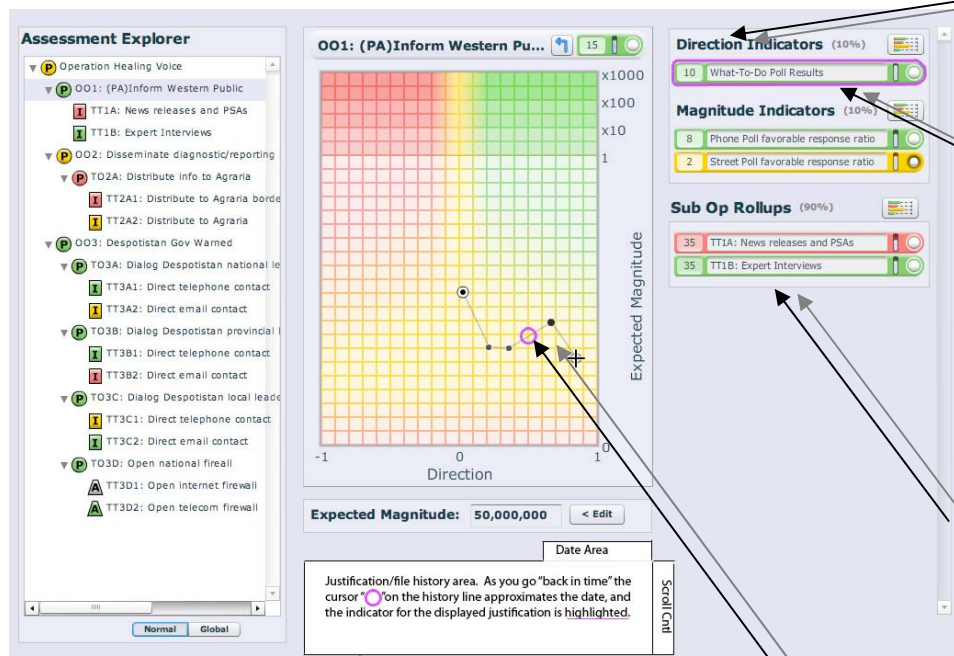

The roll-up assessment display should not be affected by the indicator history (grayed out). It needs to be clear to the user that this is a review of indicator assessments.

As justifications move backwards in time, the indicator being displayed should be highlighted, and its data reflect the changes. Scrolling back and forth in the history window should allow toggling between the older and newer states/data.

Subordinate operation roll-ups should not be affected by the history scroll-back. History reviews only indicator justifications and values. In fact, these roll-ups should be grayed out to avoid confusion.

Justification history should also allow attached files used for justifications to be opened in another window for review

The location of the history cursor on the trend line should vary with scroll control – start out on current, then slide back to show the approximate point on the trend line when an update occurred.

**Figure 37: Indicator History Concept**

A possible method of display for multiple collateral indicators is depicted in Figure 38. In the concept shown, collateral effect bounds and assessed points are shown as transparent over-lays, with the degree of transparency shown by the order in the stack. The currently selected collateral effect area is displayed as a solid fill. Non-selected areas are displayed as partially transparent fills behind this solid layer. Non-selected assessed points are depicted as partially transparent foreground symbols.

With these characteristics, this has a weakness in obscuring a smaller “background” allowable effect area under the foreground area, but preserves the “background” assessment “X” to indicate the presence of another assessment for review.

General Improvements to the Operator Interface. Several minor changes to the user interface were suggested based on a human engineering review. These include:

- 1) It is not obvious that the indicator bars on the right side of the display can be double-clicked to adjust an indicator. To improve their affordance, it is recommended to make them single-click to open and give them some mild hover effect when moused-over, possibly a background color change. Incorporating this difference will also let the user know when it can be clicked on or not since it is not always interact-able, e.g., in the edit weight set window.

- 2) Subordinate operation bars on the right side of this display behave differently than the indicator bars. It is recommended that subordinate operation bars should be represented somewhat differently to avoid confusion by the operator. A separate control could be provided; however, the tradeoff between adding an additional control versus increasing display clutter would need to be evaluated. Additional feedback from actual operators can refine this.
- 3) The operation level displayed in the center graphic, whether IFO or active IO, should be highlighted in the Assessment Explorer. Currently, the prototype initializes by showing the summary operation level, "Operation Healing Voice," but this is not highlighted in Assessment Explorer.
- 4) Remove the "X" for closing the window from the "Edit Weight Set" window to prevent the operator from clicking the X rather than using the Commit Changes button and thinking they actually made changes.

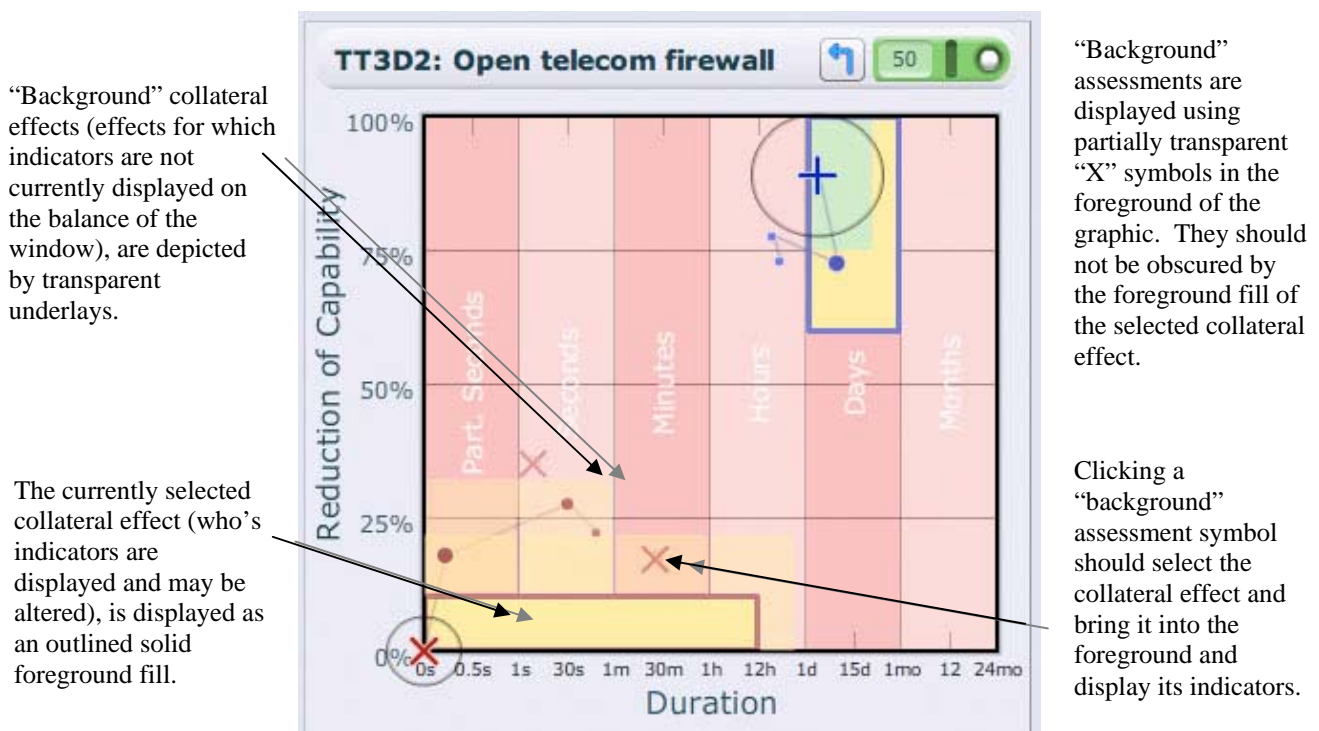

**Figure 38: Multiple Collateral Effects Concept for Active IO**

- 5) When there is only one indicator, the edit weight selection is irrelevant; thus, it is recommended to disable the edit weight selection button under this circumstance, to avoid confusion and frustration on the part of an operator who may not understand why the button exists but does not work.
- 6) Alter the depiction of active IO desired or collateral effects to ovals. Currently, rectangular regions are used to display desired and collateral effects bounds in terms of duration and degree of effect. It is likely that this may overstate the limits of these bounds near the corners of the rectangle when both factors are approaching their limits. An alternate to this display is an oval region defined at a minimum by semi-major/minor bounds that correspond to duration/degree of effect. However, as effects bounds are not necessarily symmetrical, the mathematically attractive solution of displaying a simple ellipse is insufficient. This is an area for mathematical exploration before committing to graphics prototypes, as a rigorous solution that lends itself to roll-up calculations may prove quite complex. The class of shapes known as Cassini ellipses and also Super ellipses may be useful, though the rigorous solution probably falls into the complex area of general elliptical curves.
- 7) Provide a detailed “analyst’s view” toggle for the active IO display to include point & click editing of effects bounds. The current active IO display uses multiple x-axis time scales on a single display to provide at-a-glance comparison of the rough durations of effects between IO tasks. However, this same display poorly supports the precise interpretation of durations by an analyst – at the right side of the display; the difference of a few pixels is a large change in duration.

This display should be able to be toggled to a single, uniform scale, selected by the user. If the collateral area on the scale selected extends beyond the display limits, either a pan control to move the windowed area of the display on the scale or a scale change should be implemented. Implementing this “analysts’ view” would potentially allow a click-and-drag interface for setting or modifying effect boundaries.

- 8) Provide a stand-alone capability; including local Op/effect input screens and database. As alluded to in the paragraph above, a stand-alone capability to enter at least a rudimentary IO plan, designating effects and indicators, is desired to support smaller operations, locally controlled IO operations, and compartmented activities. Ideally, this interface should be simple, with immediate feedback of the result. One suggested interface is to start with a blank tree view that contains a single, blank “Operation.” Right-clicking on this blank operation would allow a user to enter:

- Descriptive information for the selected element.
- Creation of a new operational effect subordinate to the selected level (tactical objective, IFO or IO tactical task, etc.).
- Creation of a new indicator subordinate to the selected level.

In this manner, a user familiar with the conventions of the display could rapidly construct a small plan from a blank tree, populating it with related indicators and subordinate tasks, by building and describing effects and indicators subordinate to a selected level.

Paired with this capability would be a locally resident database capable of storing both the plan and its history data.

- 9) Allow expected magnitude to be set by indicator, rather than by effect. In the Despotistan scenario, a desired IFO effect was to influence the government to allow NGO workers supported by foreign military to enter the country unmolested by either national troops or local militias. Since the desired effect impacted the entire country, the magnitude assigned was equal to the population (e.g., 24,000,000). However, the magnitude indicators used to determine the effect are numerically much smaller: detection of messages urging cooperation on official Despotistan broadcast channels (e.g., five channels possible), and observation of the withdrawal of heavy brigades from the border (e.g., twelve brigades).

In this case, the expected magnitude for each indicator differs from the expected magnitude of the effect: it can be argued that this is not an exceptional instance, but a normal occurrence in IFO assessment. It would be simpler for the assessor if indicator-specific expected magnitudes could be assigned and displayed for each indicator, so that the assessor is entering real-world numbers for the indicator rather than scaling the value in their head: the software can scale and weight the indicators for display in the overall effect summary.

Essentially, IFO assessment can be characterized as describing a population through a sort of clustered sampling method, using one or more sample frames and sampling weights. Thus in the example above, we are attempting to describe the receptivity of the population of Despotistan to foreign intervention by using two different sampling frames: 1) the content of government-controlled broadcasts, and 2) the behavior of forward based troops. Within these frames, the assessor will need to articulate a sampling strategy (e.g., When do I listen? How often do I look?). The recommended change recognizes that these two frames, while assumed to have a correlation to the affected population, in reality have their own individual magnitude. With this approach, if the assessor can fully characterize the size and distribution of the sample frame, it is possible to evaluate his selected sample strategy and assign a confidence limit.

## 12. Referenced Documents

AFOTTP 2-3.2, Air Force Operational Tactics, Techniques and Procedures, *Air and Space Operations Center*, 13 Dec 2004

AFTTP 3-3, Air Force Tactics, Techniques and Procedures, Operational Employment Air and Space Operations Center, 1 Nov 2007

The Commander's Handbook for an Effects-Based Approach to Joint Operations, Joint Warfighting Center, 24 Feb 2006

Supplement One to the Commander's Handbook for an Effects-Based Approach to Joint Operations, Joint Warfighting Center, 13 March 2006

Effects Based Approach to Operations, Lexicon of Related Terms and Definitions (EBO Lexicon), AFDC/CV, Maxwell AFB, 28 June 2006

Vicente, K.J. (1999). Cognitive work analysis: Toward safe, productive and healthy computer-based work. Hillsdale, NJ; Lawrence Erlbaum.

Klein, G.A., Calderwood, R. and McGregor, D. (1989). Critical decision method for eliciting knowledge. *IEEE Transactions on Systems, Man and Cybernetics*, 19(3), 462 – 472.

Applications Programming in Smalltalk-80™: How to use Model-View-Controller (MVC). Steve Burbeck, Ph.D, 1987, 1992. Online, University of Illinois at Urbana-Champaign. (12 Aug, 2008). <http://st-www.cs.uiuc.edu/users/smarch/st-docs/mvc.html>

Java BluePrints – J2EE Patterns. Sun Microsystems, Inc. Online. (12 Aug, 2008). <http://java.sun.com/blueprints/patterns/MVC-detailed.html>.

Using Perspectives in the Eclipse UI. Object Technology International, Inc., 2001. Online, Eclipse.org. (13 Aug, 2008). <http://www.eclipse.org/articles/using-perspectives/PerspectiveArticle.html>.

JfreeChart. Object Refinery Limited, 2005-2008. Online. (13 Aug, 2008). <http://www.jfree.org/jfreechart/>.

Batik SVG Toolkit. The Apache Software Foundation, 2000-2008. Online. (13 Aug 2008). <http://xmlgraphics.apache.org/batik/>

H2 Database Engine. The H2 Group. Online. (13 Aug, 2008). <http://h2database.com>

Heaton, H. H. (2007). HE-AOC Ops Review 30-May-2007 (HE-AOC Ops Review 30May07\_HHH.ppt)

### 13. Acronyms and Abbreviations

ACC	Air Combat Command	DASEA	Dynamic Air and Space Effects-based Assessment
ACUMEN	Advanced Capability for Understanding and Managing Effects Networks	DMPI	Desired Mean Point of Impact
AECV	Action-Effects Contrast Visualization	DSE	DMPI – Sortie – Equivalents
AFC2ISRC	Air Force Command and Control, Intelligence, Surveillance, and Reconnaissance Center	EBA	Effects-Based Assessment
AFDC	Air Force Doctrine Center	EBAO	Effects-Based Approach to Operations
AFTTP	Air Force Tactics, Techniques, and Procedures	EBO	Effects-Based Operations
AFRL	Air Force Research Laboratory	EBOD	Effects-Based Operational Design
AIR	Assessment Information Request	EBP	Effects-Based Plan
AOC	Air Operations Center	ESC	Electronic Systems Command
ATD	Advanced Technology Demonstration	FDA	Functional Damage Assessment
ATF	Air Force Assessment Task Force	FFDB	Functional Flow Block Diagrams
ATO	Air Tasking Order	GCIC	Global Cyberspace Integration Center
BDA	Bomb Damage Assessment	GEM-S	Global Effects Matrix-Synchronization
C2ISR	Command and Control Intelligence Surveillance and Reconnaissance	GEV	Geo-spatial Effects Visualization
CART	Combat Automation Requirements Testbed	GPN	Goal Process Nodes
CFC	Combined Forces Commander	IAM	Indicator Analysis Manager
CMMI <sup>SM</sup>	Capability Maturity Model <sup>®</sup> Integration	IFO	Influence Operation
COA	Course Of Action Analysis	IO	Information Operations
CSA	Cognitive Systems Analysis	IRR	Information Relationship Requirements
CSE	Cognitive Systems Engineering	ISRD	Intelligence Surveillance and Reconnaissance Division
CWE	Cognitive Workflow Element	IWPC	Information Warfare Planning Capability
CWR	Cognitive Work Requirements	JEFX	Joint Expeditionary Forces Experiment

JFACC	Joint Forces Air Component Commander	Assessment
JFC	Joint Forces Commander	SDT Strategy Development Team
JFCOM	Joint Forces Command	SME Subject Matter Expert
JIOWC	Joint Information Operations Warfare Center	SoS Systems of Systems
JMEM	Joint Munitions Effectiveness Manual	SPT Strategy Plans Team
MEA	Mission Effects Assessment	TA Tactical Assessment
MoE	Measures of Effectiveness	TAC Tactical Assessment Cell
MoP	Measures of Performance	TAT Targets and Assessment Team
MVC	Model-View-Controller	TBMCS Theater Battle Management Core System
OA	Operational Assessment	TBONE Theater Battle Operations Net-centric Environment
OEAVT	Operational Effect Assessment Visualization Tool	TI3 TBONE-IWPC Indicator Interface
OAT	Operational Assessment Team	TIM Technology Impact Matrix
OE	Operational Environment	TLE Tactical Line of Effect
OLE	Operational Line of Effect	TO Tactical Objective
OO	Operational Objective	TRL Test Readiness Level
PDA	Physical Damage Assessment	TT Tactical Tasks
PDS	Persistent Data Store	TTLE Tactical Task Line of Effect
PEL	Primary Effects List	TTO Tactical Task Objectives
PMESII	Political, Military, Economic, Social, Infrastructure, and Information	TTP IO Tactics, Techniques and Procedures
SCVOA	System for Cognitive Visualization of Operational	WAIT-C Warfighter Analysis of Innovative Technologies and Concepts workshop
		XGen Next-Generation Assessment Environment

This page blank intentionally.

# **APPENDIX A**

## **OEAVT CONCEPT MAPS AND CRITICAL DECISION SPREADSHEETS**

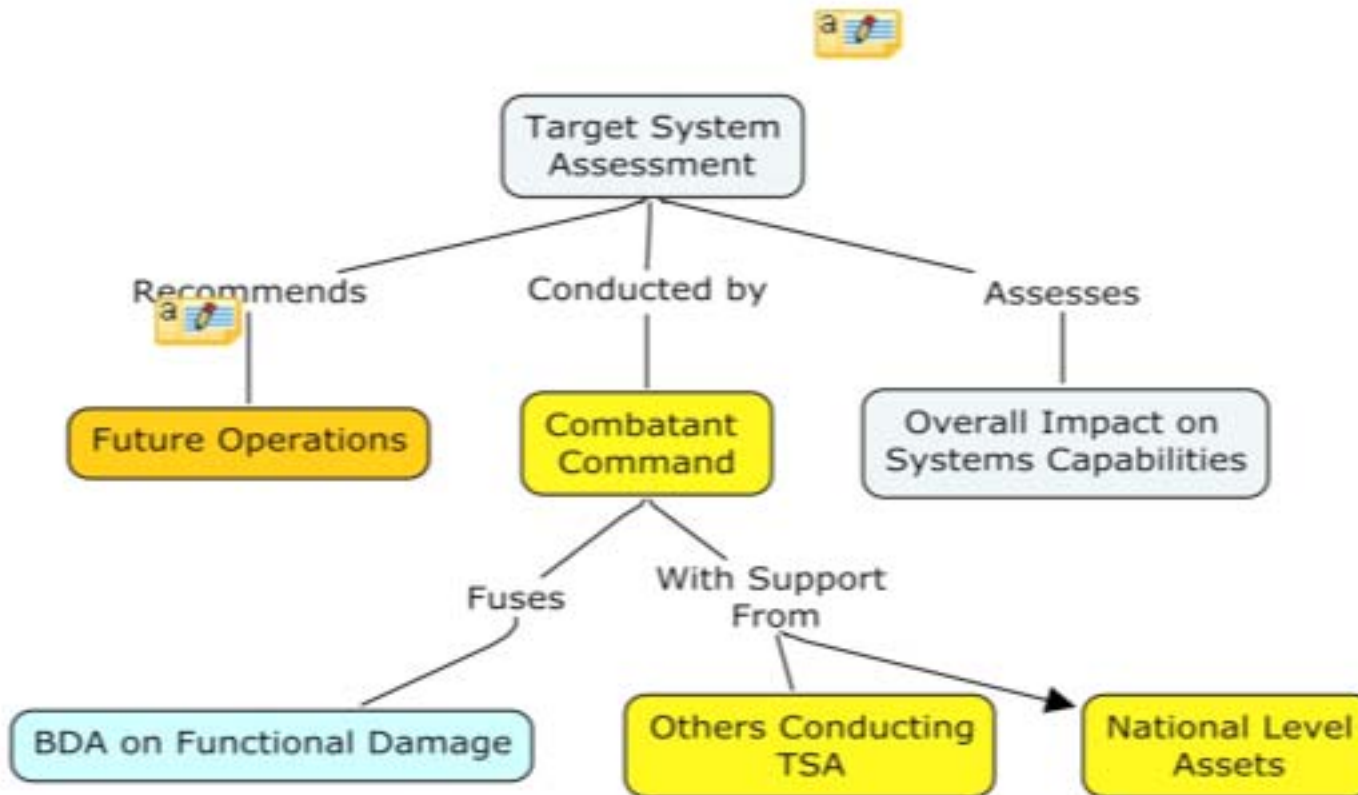

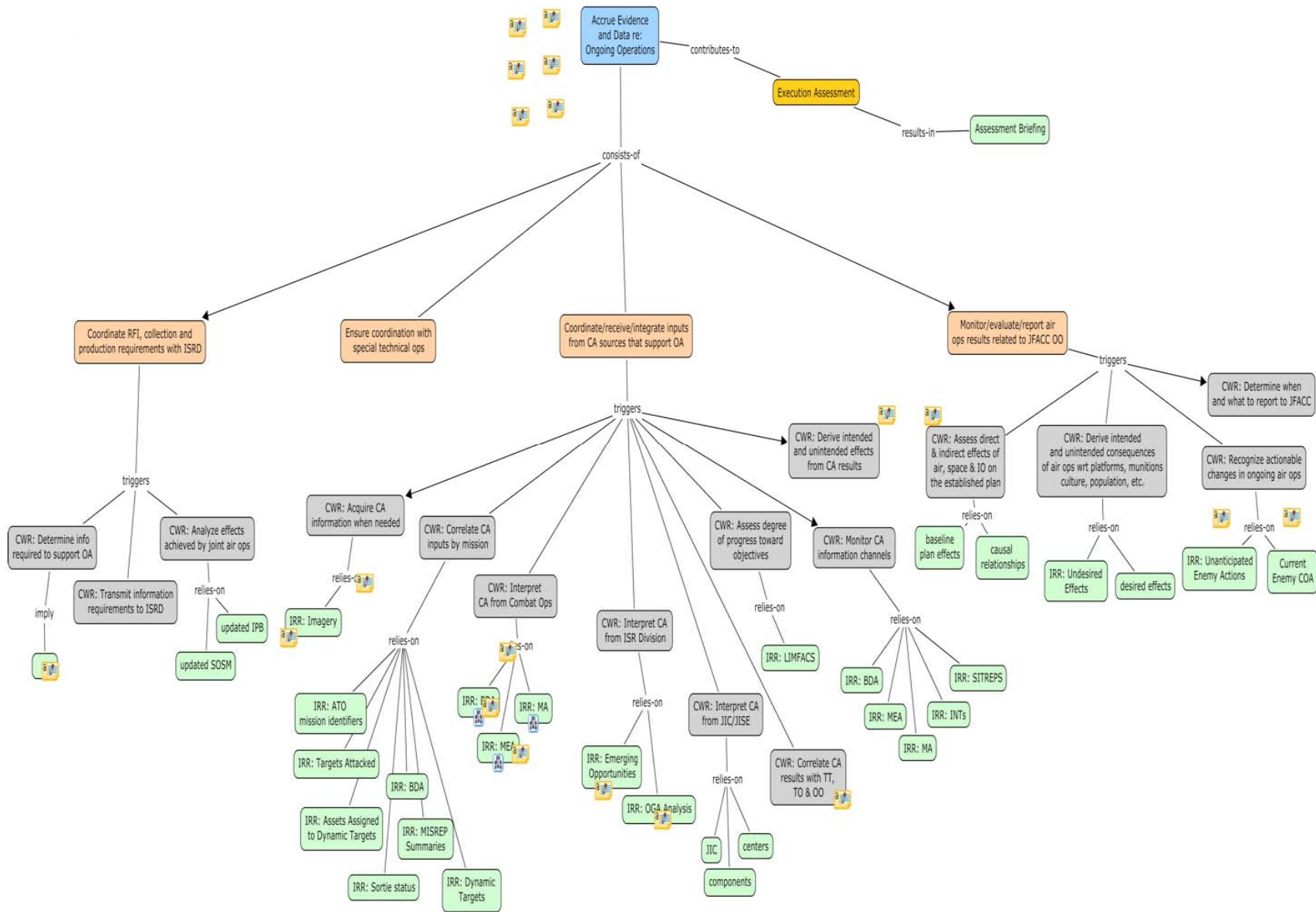

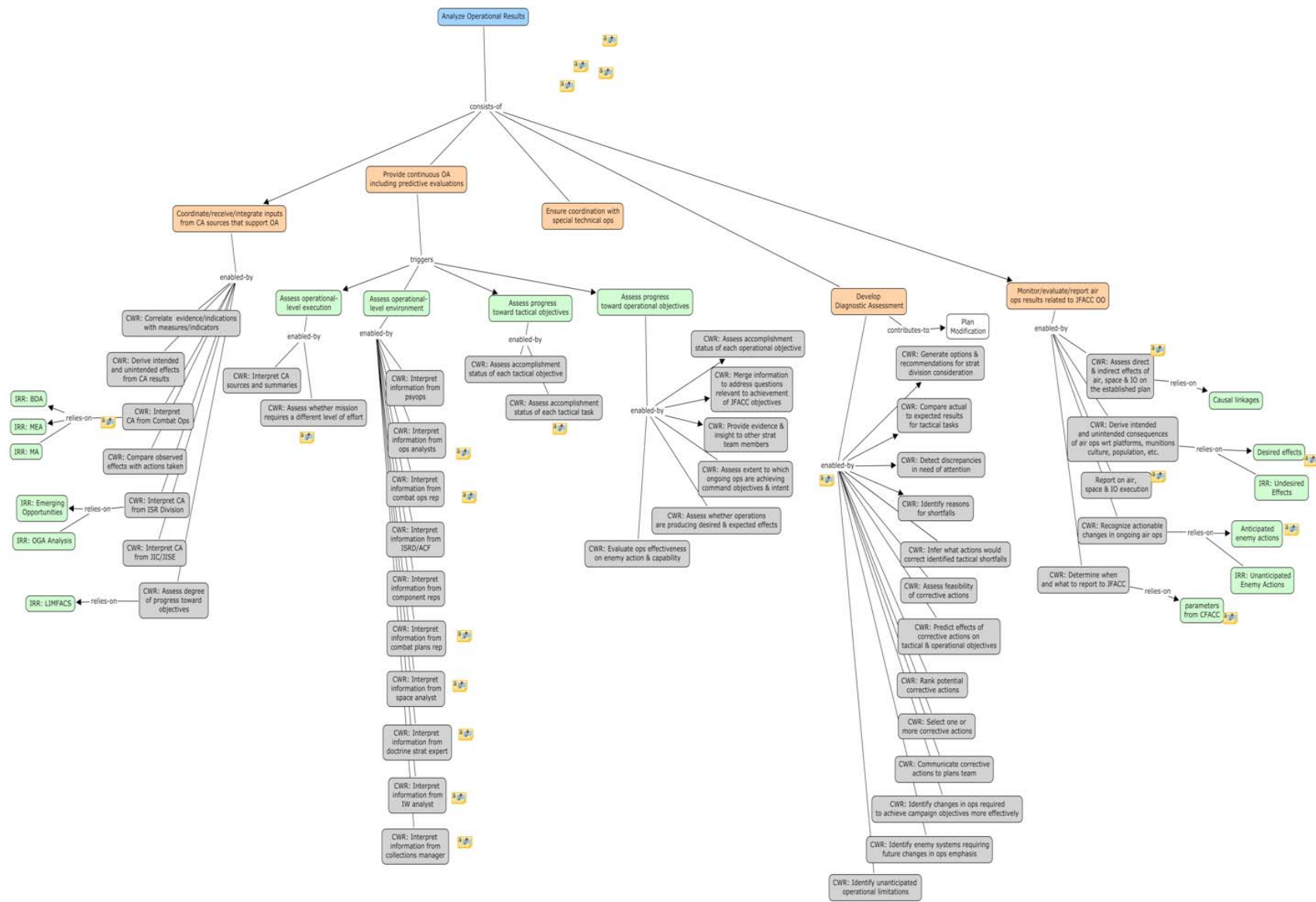

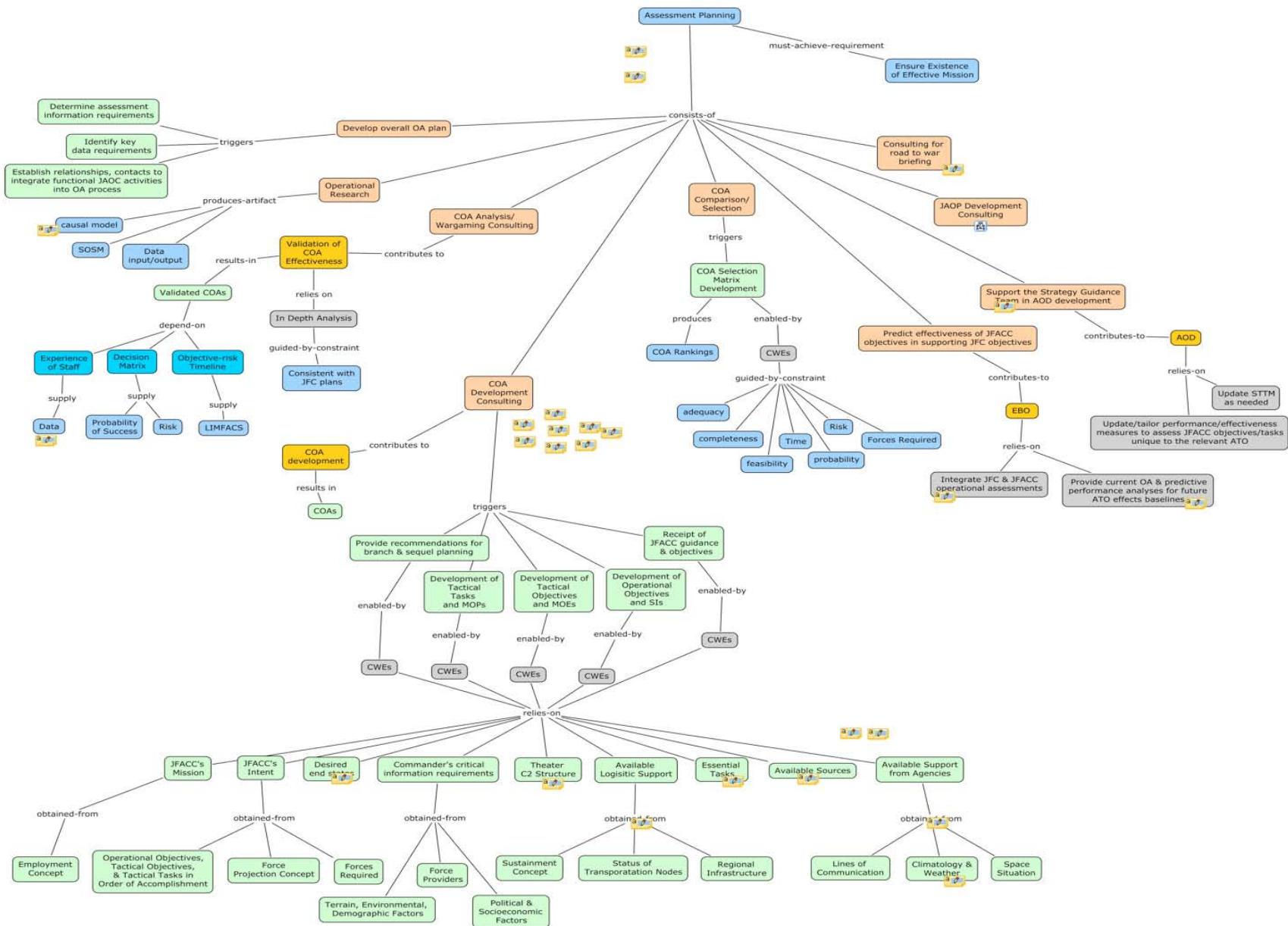

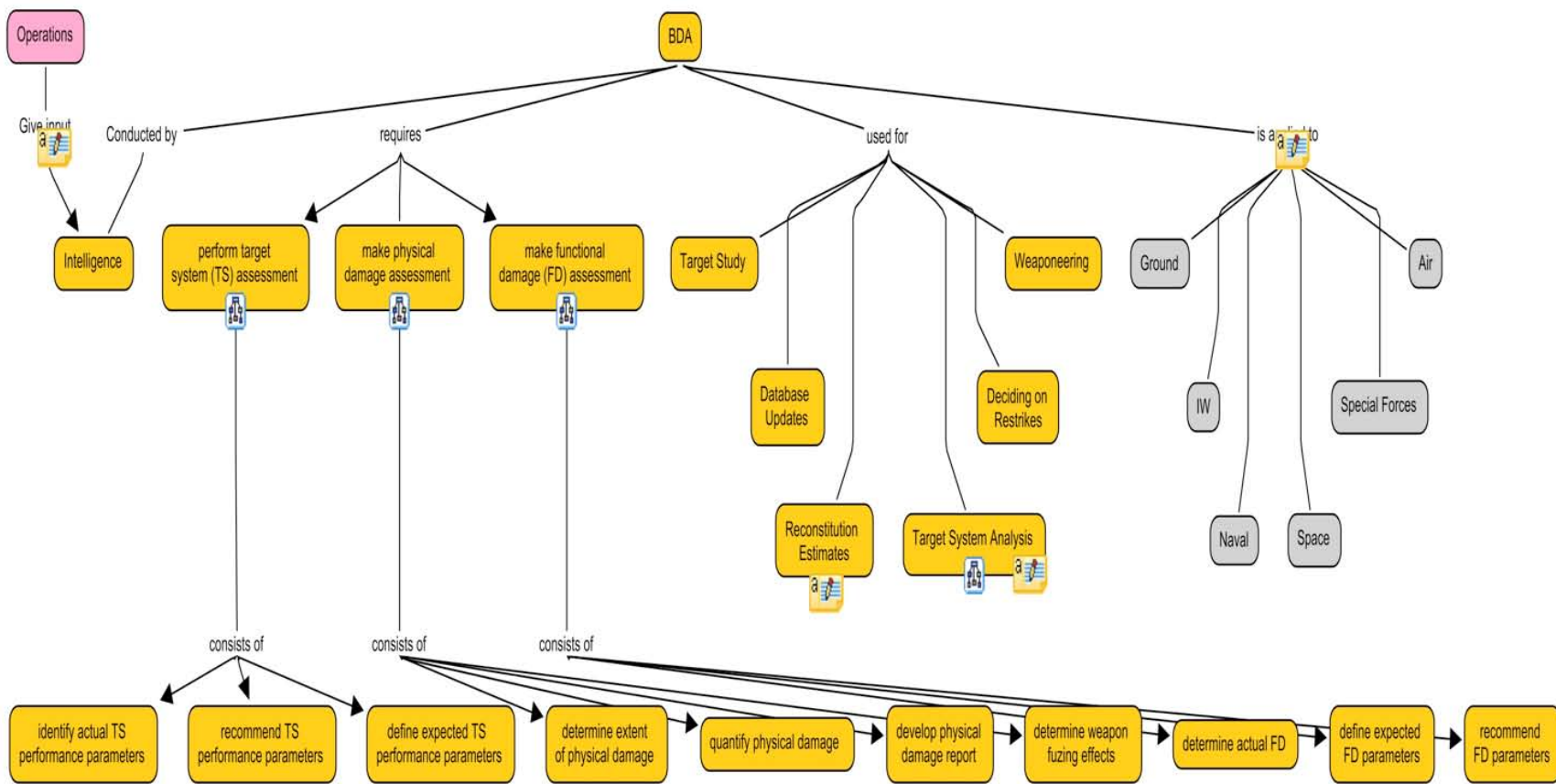

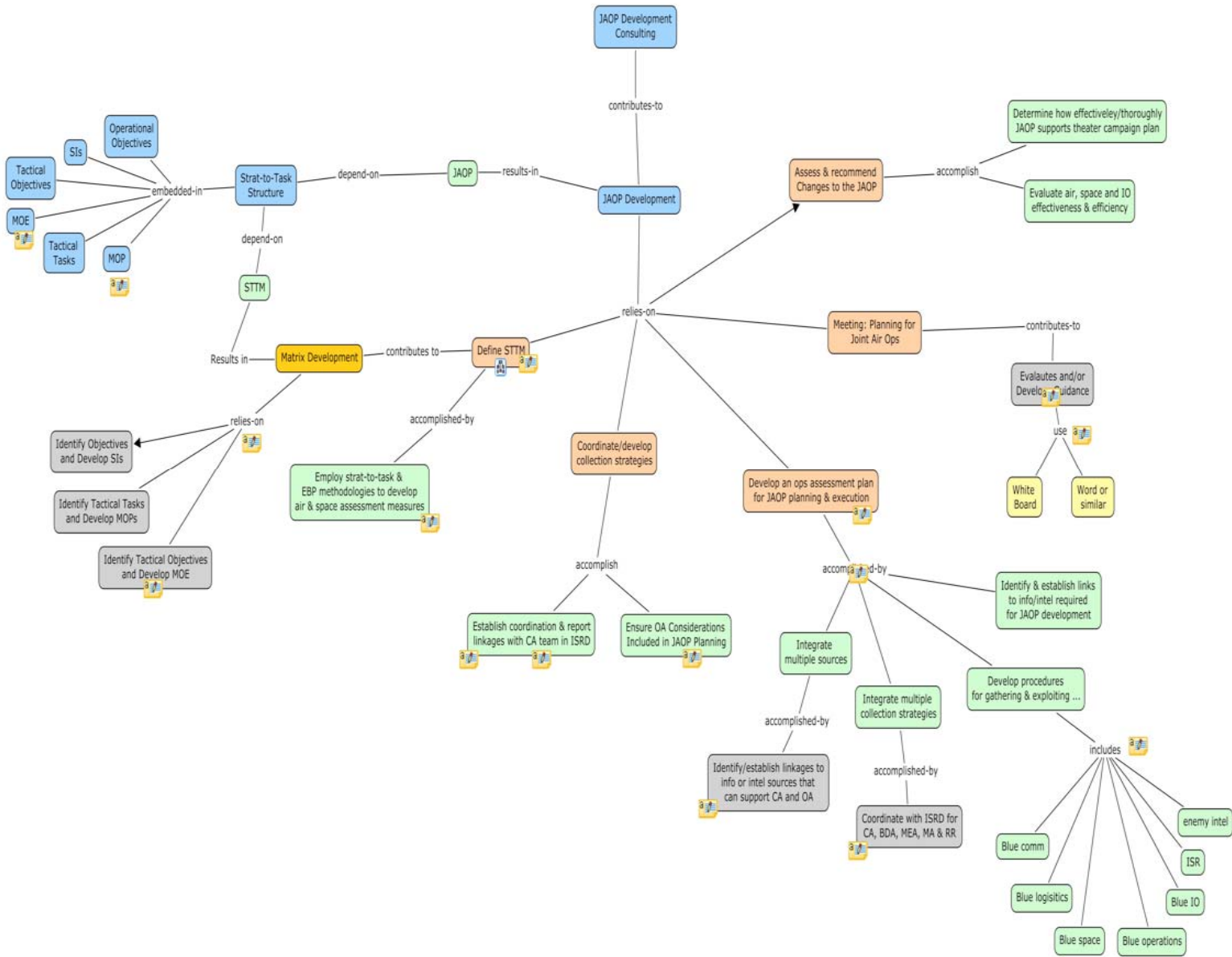

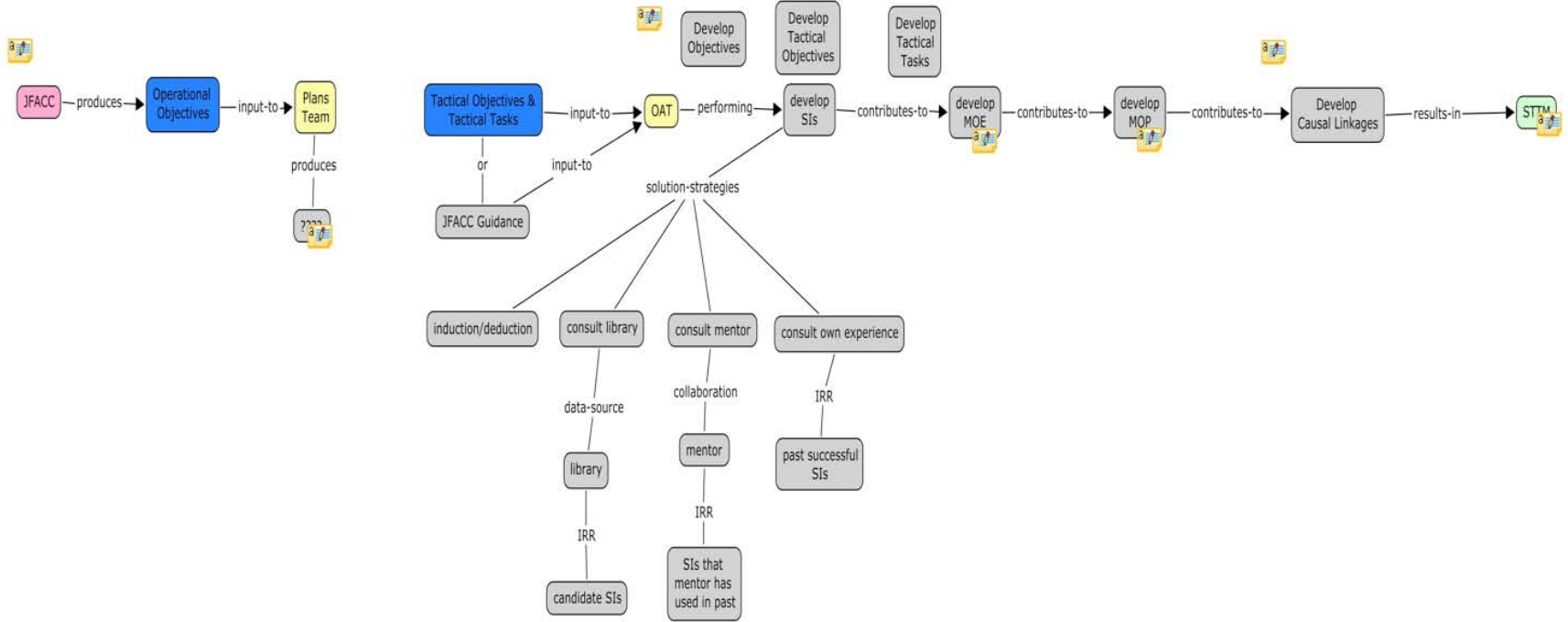

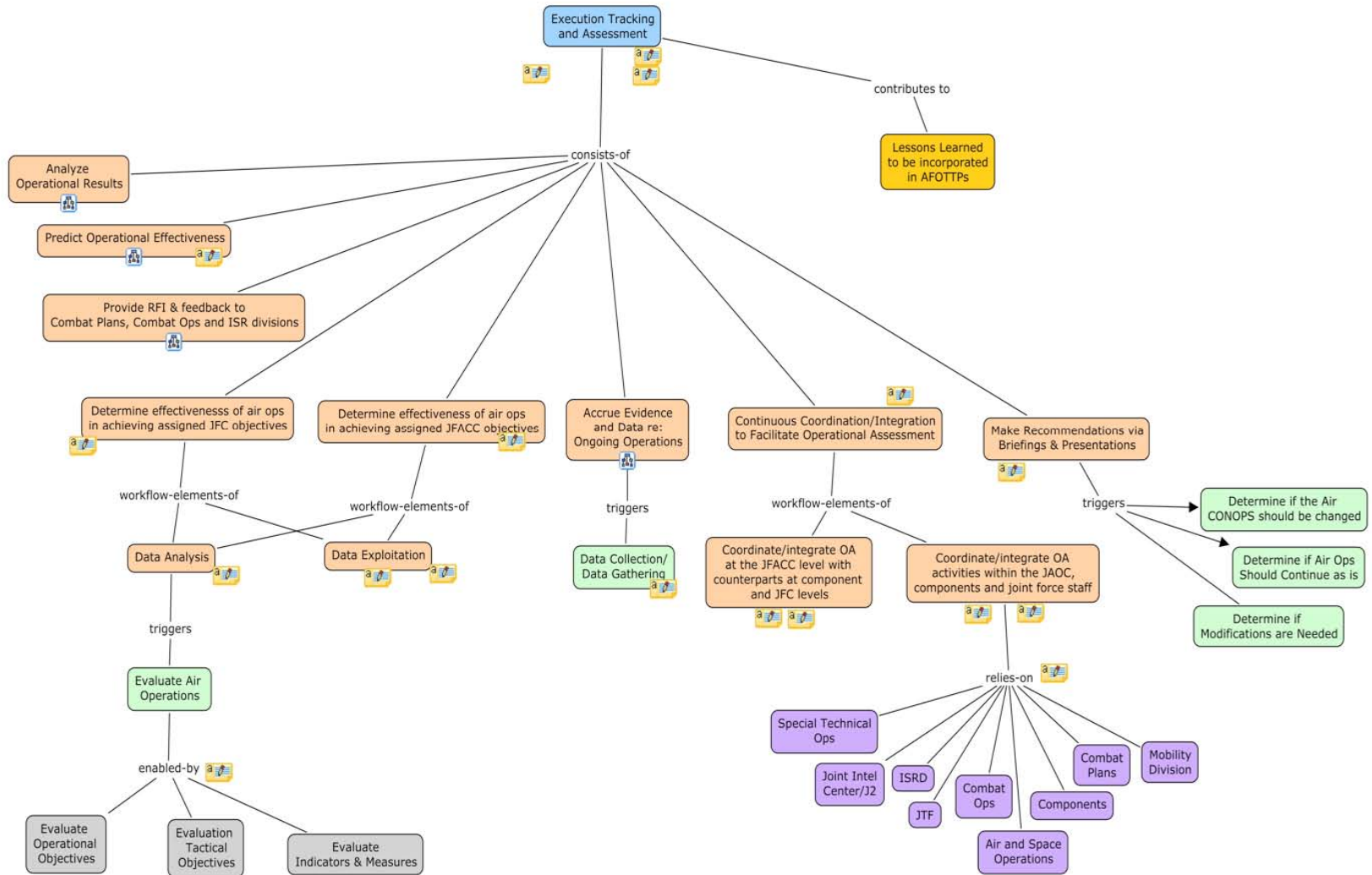

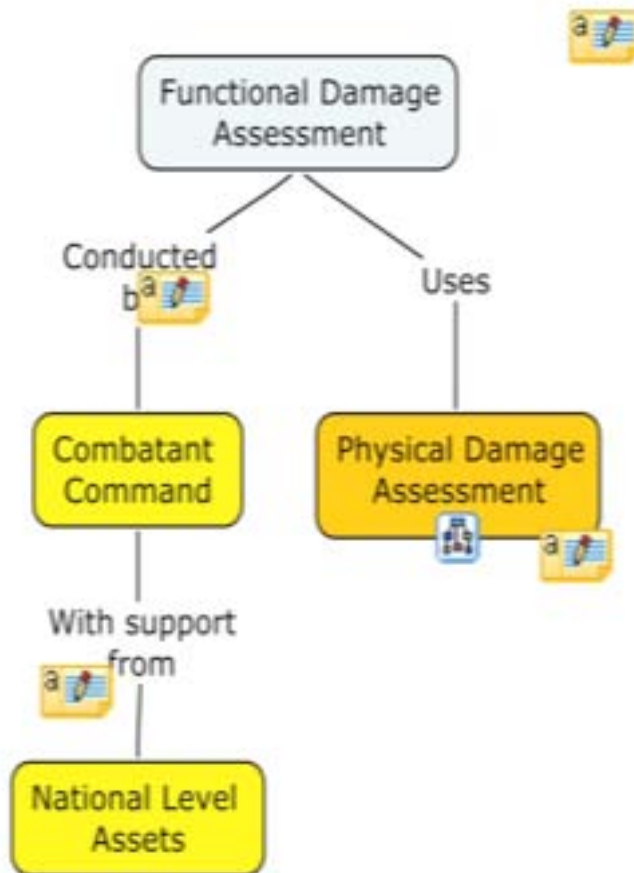

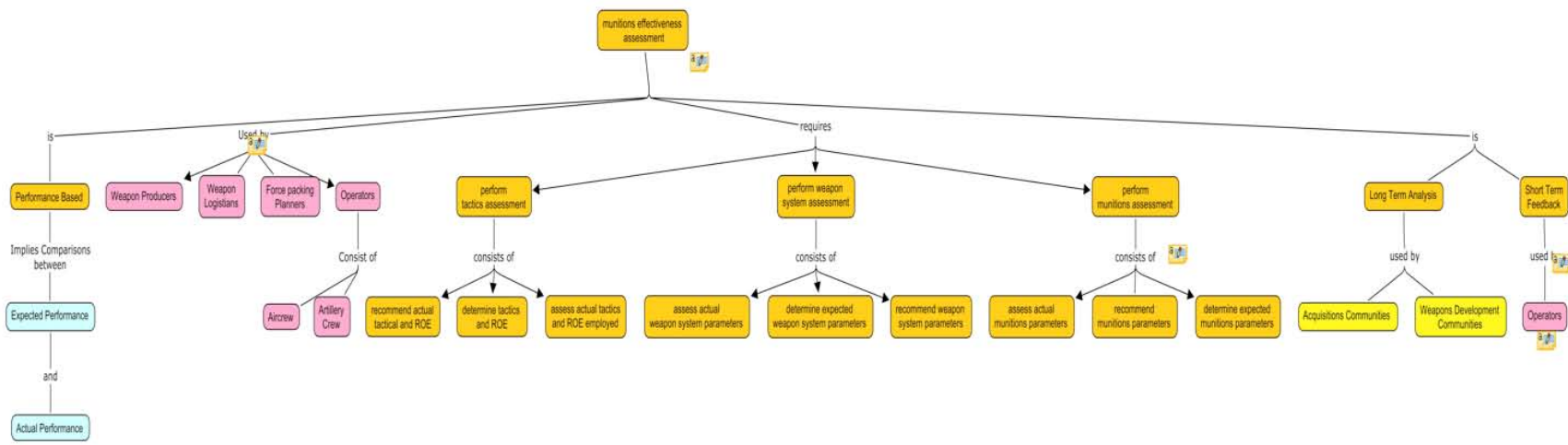

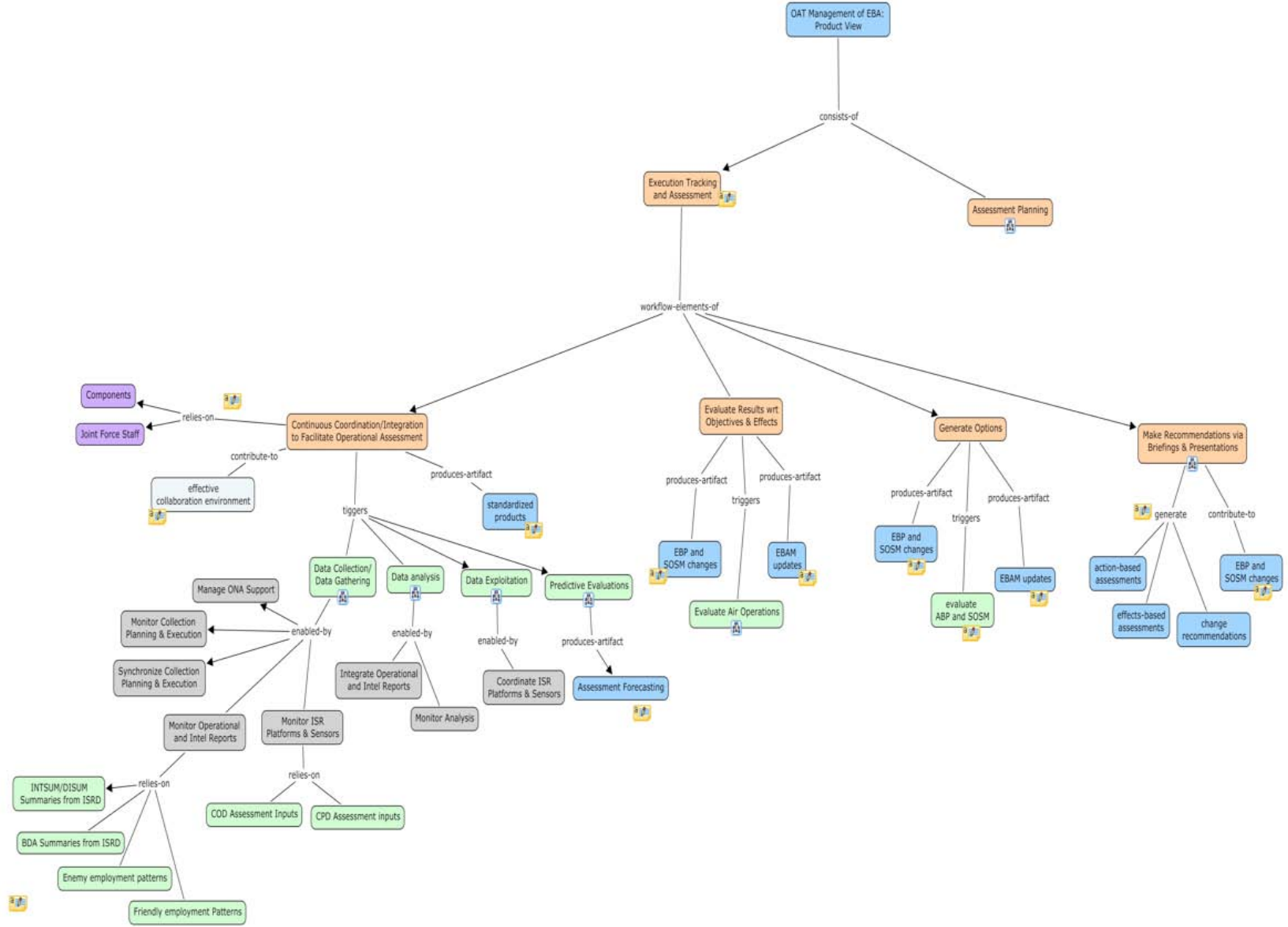

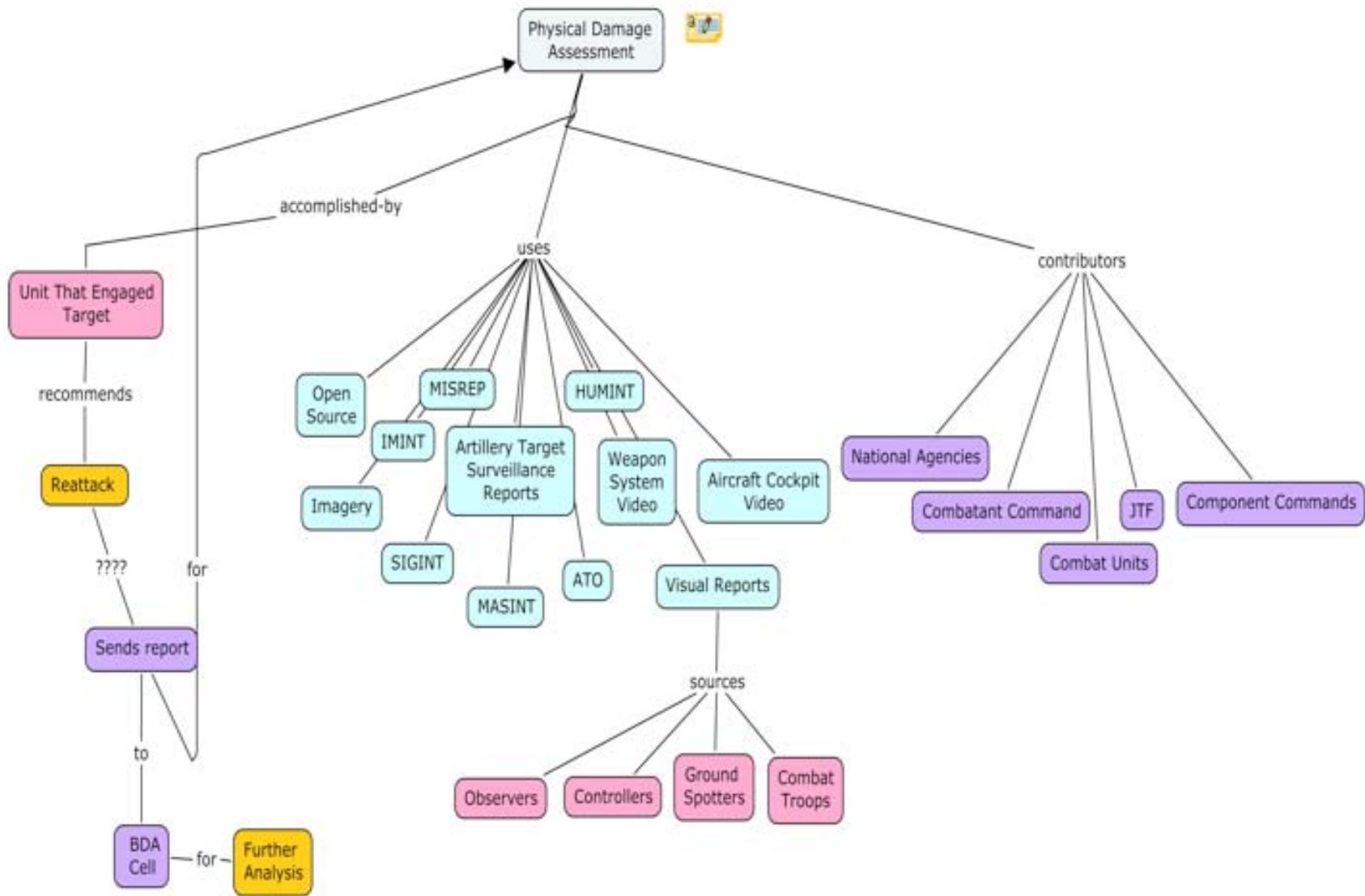

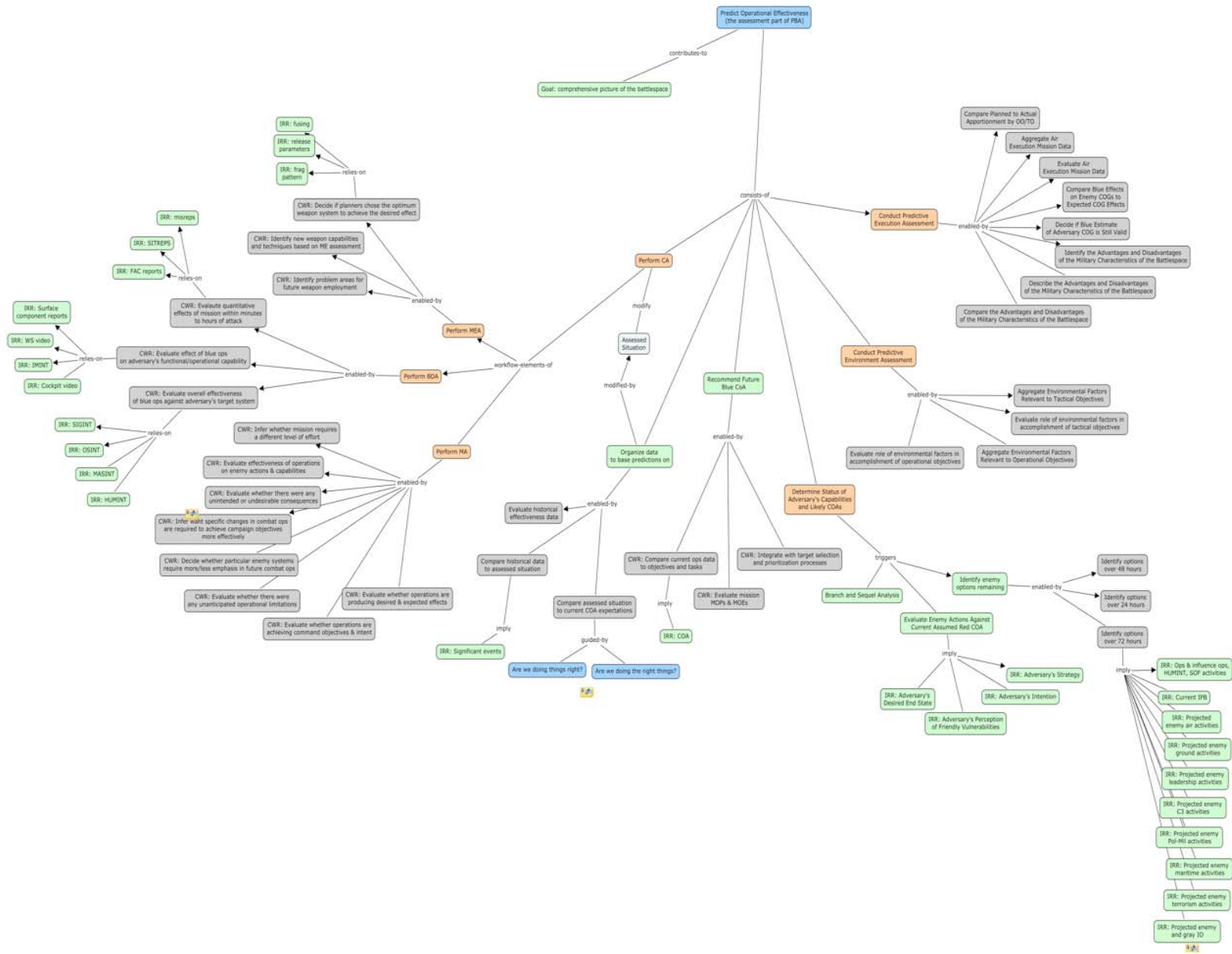

**Provide Continuous OA Including Predictive Evaluations**

Provide Continuous OA Including Predictive Evaluations										
Reference Code	#	CWR	IRR	Critical Cue and/or Factors	Critical Decisions	Actions	Common Errors	Communicate with	Data Products used	Requirements
	1	Assess operational level execution	*DMPI status  *SORTI Status  *WOE  *Actual vs planned  *Resources available/not available  *Objectives  *Desired effects  *Mission successes/failures	*Plan vs actual	*Determine if execution is going as planned	*Interpret CA sources and summaries  *Assess mission to check if it requires a different level of effort				*The system shall aid in determining if actual actions are taking place as planned

**Provide Continuous OA Including Predictive Evaluations**

Reference Code	#	CWR	IRR	Critical Cue and/or Factors	Critical Decisions	Actions	Common Errors	Communicate with	Data Products used	Requirements
	2	Assess operational level environment	*Weather *Terrain *Air space	*Change in weather *Change in terrain *Change in air space	*Determine if weather, terrain, and/or air spaces current/future will affect plan	*Interpret information from psyops  *Interpret information from ops analyst  *Interpret information from combat ops rep  *Interpret information from ISRD/ACF  *Interpret information from component rep  *Interpret information from combat plans rep  * Interpret information from space analyst  *Interpret information from doctrine strat expert  *Interpret information from IW analyst		*PSYOPS  *Ops Analysts  *Combat Ops rep  *ISRD/ACF  *Component Reps  *Combat Plans Rep  *Space Analyst  *Doctrine Strat Expert  *IW Analyst  *Collections Manager		*The system shall aid in determining if weather, terrain, and/or air spaces current/future will affect plan

**Provide Continuous OA Including Predictive Evaluations**

Reference Code	#	CWR	IRR	Critical Cue and/or Factors	Critical Decisions	Actions	Common Errors	Communicate with	Data Products used	Requirements
						*Interpret information from collections manager				
	3	Assess progress toward tactical objectives	*Accomplishment status of each TO *Accomplishment status of each TT *DMPI status *SORTI Status *WOE *Actual vs planned *Resources available/not available *Objectives *Desired effects	*Mission failures / successes	*Determine if tactical objectives will be achieved	Assess status				*The system shall aid in determining if tactical objectives will be achieved

**Provide Continuous OA Including Predictive Evaluations**

Provide Continuous OA Including Predictive Evaluations										
Reference Code	#	CWR	IRR	Critical Cue and/or Factors	Critical Decisions	Actions	Common Errors	Communicate with	Data Products used	Requirements
			*Mission successes/failures							

**Provide Continuous OA Including Predictive Evaluations**

Reference Code	#	CWR	IRR	Critical Cue and/or Factors	Critical Decisions	Actions	Common Errors	Communicate with	Data Products used	Requirements
	4	Assess progress toward operational objectives	*Accomplishment status of each OO  *Command objectives and intent  *Desired and expected effects  *Enemy actions, plans and capabilities  *Aggregated DMPI and SORTI status	*Mission failures / successes	*Determine if operational objectives will be achieved	*Assess accomplishment of each OO  *Merge information to address questions relevant to achievement of JFACC objectives  *Provide evidence to other strat team members  *Assess extent to which ongoing ops are achieving command objectives and intent  *Evaluate ops effectiveness on enemy action and capability				*The system shall aid in determining if operational objectives will be achieved

## Support the Strategy Guidance Team in AOD Development

Reference Code	#	CWR	IRR	Critical Cue and/or Factors	Critical Decisions	Actions	Common Errors	Tools used	Communicate with	Data Products used	Comments	Requirements
AFOTTP	1	Update/tailor performance measures to assess JFACC objectives and tasks unique to the relevant ATO	*Objectives		*Decide when measures need to be updated or changed  *Determine how to change them  *Determine if the measures or the objectives need to be changed	*Update / tailor measure				*JFACC guidance  *ATO  *MOE, MOP, Sis		*The system shall have access to Objectives  *The system shall have access to Tasks  *The system shall have access to ATO  *The system shall allow have access to all measures associated with tasks and objectives  *The system shall allow changes to be made to measures
AFOTTP	2	Update/tailor effectiveness measures to assess JFACC objectives and tasks unique to the relevant ATO	*Objectives		*Decide when measures need to be updated or changed  *Determine how to change them  *Determine if the measures or the objectives need to be changed							*The system shall provide the capability to view JFACC objectives, tasks, and their associated measures, and the AOD all at once

## Coordinate/Receive/Integrate Inputs from CA Sources that Support OA

Reference Code	#	CWR	"IRR"	Critical Cue and/or Factors	Critical Decisions	Actions	Common Errors	Tools used	Communicate with	Data Products used	Comments	Requirements
	1	Acquire CA information when needed	<ul style="list-style-type: none"> <li>*Know where information is located</li> <li>*Know source of information</li> <li>*Know time of information</li> <li>*Know what mission CA is for</li> </ul>	<ul style="list-style-type: none"> <li>*Source</li> <li>*Timing</li> <li>*Accuracy</li> <li>*Reliability</li> </ul>	<ul style="list-style-type: none"> <li>*Determine usefulness of report</li> <li>*Determine if report lines up with other report</li> </ul>	<ul style="list-style-type: none"> <li>*Read reports</li> <li>*Compare to other reports</li> </ul>	<ul style="list-style-type: none"> <li>*Not receive report</li> <li>*Not receive report in timely manner</li> </ul>	<ul style="list-style-type: none"> <li>*Web</li> <li>*Network</li> </ul>	<ul style="list-style-type: none"> <li>*Intel</li> <li>*Components</li> </ul>	Imagery	<p>The biggest problems are receiving the data and receiving it in a timely manner</p>	<ul style="list-style-type: none"> <li>*The system shall provide a way to receive combat assessment information</li> <li>*The system shall provide a way to request information</li> <li>*The system shall provide a way to "alert" people that a new report is available</li> </ul>
	2	Correlate CA inputs by mission	<ul style="list-style-type: none"> <li>*ATO mission identifiers</li> <li>*Targets attacked (DMPs)</li> <li>*Assets assigned to dynamic targets</li> <li>*Sortie status</li> </ul>	<ul style="list-style-type: none"> <li>*Reason why mission failed</li> </ul>	<ul style="list-style-type: none"> <li>*Determine impact of mission success/failure for the upcoming mission</li> </ul>					<ul style="list-style-type: none"> <li>*BDA</li> <li>*MISREP Summaries</li> </ul>		<ul style="list-style-type: none"> <li>*The system shall aid in correlating CA inputs to the mission</li> </ul>

## Coordinate/Receive/Integrate Inputs from CA Sources that Support OA

Coordinate/Receive/Integrate Inputs from CA Sources that Support OA												
Reference Code	#	CWR	"IRR"	Critical Cue and/or Factors	Critical Decisions	Actions	Common Errors	Tools used	Communicate with	Data Products used	Comments	Requirements
			*Mission successes  *Mission failures  *Reasons why missions failed									
	4	Interpret CA from ISR	*Emerging Opportunities  *OGA analysis  *Sortie/DMPI Status  *Mission successes  *Mission failures  *Reasons why mission failed	*DMPI Success / Failures  *Explanations of missions	*Determine if a re-roll is needed  *Determine if mission was a success/failure  *Determine if a modification to the plan is needed	*Make recommendations				*ISR reports		*The system shall provide access to ISR data (summaries)  *The system shall provide a way to compare data and rate it accordingly to usefulness

## Coordinate/Receive/Integrate Inputs from CA Sources that Support OA

Reference Code	#	CWR	"IRR"	Critical Cue and/or Factors	Critical Decisions	Actions	Common Errors	Tools used	Communicate with	Data Products used	Comments	Requirements
	5	Correlate CA results with TT, TO and OO	*Objectives *WOE *Priorities *Mission success/failures	*CA doesn't correlate with other data *CA indicates effects are not being achieved	*Determine if objectives are being met *Determine if WOE should be maintained or changed *Determine if data correlates or contradicts one another *Determine if we are maintaining priorities *Determine if a modification to the plan is needed	*Make recommendations				*ISR reports *Other summaries		*The system shall aid in correlating CA results with TT, TO, and OO *The system shall aid in determining if objectives are being met *The system shall aid in determining if WOE should be maintained or changed *The system shall aid in determining if data correlates or contradicts one another *The system shall aid in determining if we are maintaining priorities *The system shall aid in determining if a modification to the plan is needed

**Coordinate/Receive/Integrate Inputs from CA Sources that Support OA**

Reference Code	#	CWR	"IRR"	Critical Cue and/or Factors	Critical Decisions	Actions	Common Errors	Tools used	Communcate with	Data Products used	Comments	Requirements
	6	Assess Degree of progress toward objectives	*Plan  *WOE  *Time (day and hours)  *Where you are actually compared to plan	*Time  *WOE  *Actual vs Planned	*Determine if objectives are being met  *Determine if WOE should be maintained or changed  *Determine if a modification to the plan is needed  *Determine if you are ahead/behind plan  *Determine if another day needs to be added to achieve objectives					LIMFACS		*The system shall display progress towards objectives  *The system shall display the Plan  *The system shall display the WOE  *The system shall display the Time (day and hours)  *The system shall display where you are actually compared to plan  *The system shall aid in determining if objectives are being met  *The system shall aid in determining if WOE should be maintained or changed  *The system shall aid in determining if a modification to the plan is needed  *The system shall aid in determining if you are ahead/behind plan  *The system shall aid in determining if another day needs to be added to

**Coordinate/Receive/Integrate Inputs from CA Sources that Support OA**

Reference Code	#	CWR	"IRR"	Critical Cue and/or Factors	Critical Decisions	Actions	Common Errors	Tools used	Communicate with	Data Products used	Comments	Requirements
												achieve objectives

## Coordinate/Receive/Integrate Inputs from CA Sources that Support OA

Reference Code	#	CWR	"IRR"	Critical Cue and/or Factors	Critical Decisions	Actions	Common Errors	Tools used	Communicate with	Data Products used	Comments	Requirements
	7	Derive intended and unintended effects from CA results	*Know what the intended effects are	*Adversary behaviors  *System behaviors	*Determine if effects are being achieved  *Determine what is causing the effect  *Determine how the effect is being achieved and how long it will last	*Request more intel data						*The system shall provide a way to derive unintended and intended effects from CA results  *The system shall aid in determining if effects are being achieved  *The system shall aid in determining what is causing the effect  *The system shall aid in determining how the effect is being achieved and how long it will last
	8	Monitor CA information channels	*Know what to monitor	*Alert that something new is available	*Determine what objective the report summarizes	*Read summary	*Not knowing that something new is available			*BDA  *MEA  *MA  *INTS  *SITREPS		*The system shall provide a capability to monitor CA channels  *The system shall organize data

## COA Analysis/Wargaming Consulting

Reference Code	#	CWR	IRR	Critical Cue and/or Factors	Critical Decisions	Actions	Common Errors	Tools Used	Communicate with	Data Products used	Requirements
MM1, Reg	1	Blue COA war gamed against Red COA		<ul style="list-style-type: none"> <li>*completeness</li> <li>*Feasibility</li> <li>*Probability of friendly losses</li> <li>*Time to attain objectives and desired effects</li> <li>*Collateral damage</li> </ul>	<ul style="list-style-type: none"> <li>*Form their recommendation to the commander on which COA option to adopt</li> <li>*Do the assumptions have any impact on attaining the desired effects?</li> <li>*If I achieve the desired effect, how will the enemy respond?</li> <li>*How likely is this reaction?</li> <li>*How will I know?</li> <li>*Will it add to or subtract from my objective?</li> </ul>	<ul style="list-style-type: none"> <li>*May modify COA</li> <li>*Consider all facts and assumptions of the estimate and their possible effect on the action</li> <li>*Consider conflict termination issues. Think through own action, adversary reaction, and counteraction.</li> <li>*Assess the likelihood of achieving objectives and desired effects given likely enemy reactions (Look at the World through the eyes of the adversary)</li> </ul>					<ul style="list-style-type: none"> <li>*The system shall provide the capability to wargame COAs</li> <li>*The system shall provide a basic framework for the development of the COAs</li> <li>*The system shall "play" the outcome of COAs</li> <li>*The system shall identify weaknesses in the COA</li> <li>*The system shall display friendly losses</li> <li>*The system shall display both desired effects and undesired effects</li> <li>*The system shall display collateral damages based on COAs</li> <li>*The system shall display options to let user choose the best COAs</li> </ul>

## COA Analysis/Wargaming Consulting

Reference Code	#	CWR	IRR	Critical Cue and/or Factors	Critical Decisions	Actions	Common Errors	Tools Used	Communicate with	Data Products used	Requirements
					*If unintended effects occur, how might the enemy respond?  *How likely is this reaction, given the unintended effects?  *How will I know?  *How will allies/coalition partners respond?  *Why do I believe all of the above?						*The system shall provide a reporting mechanism  *The system shall allow modifications to COAs
MM1, REg	2	When COA are modified, recalculates the probability of attaining commanders intent as well as the changes in the criteria values	*know how to modify COA	*Significance of changes  *How changes affect the COA in regards to intent	*Determine if calculation indicates COA needs to be changed  *Determine how and where COA needs to be modified  *Determine if COA needs	*Recommend changes that enhance the COA					*The system shall recalculate the probability of attaining commanders intent as well as the changes in the criteria values when COAs are modified

## COA Analysis/Wargaming Consulting

Reference Code	#	CWR	IRR	Critical Cue and/or Factors	Critical Decisions	Actions	Common Errors	Tools Used	Communicate with	Data Products used	Requirements
					to be thrown out						
Reg	3	Create sequel plans that allow friendly forces to capitalize on achievement of objectives and desired effects									*The system shall allow the creation of sequel plans that allow friendly forces to capitalize on achievement of objectives and desired effects
Reg	4	Assess the likelihood of Undesired Effects occurring given the likely enemy reactions	<ul style="list-style-type: none"> <li>*History of adversary</li> <li>*Adversary allies</li> <li>*Adversary capabilities</li> <li>*Adversaries intent</li> </ul>	*Adversary behaviors	<ul style="list-style-type: none"> <li>*How might the enemy act to produce Undesired Effects?</li> <li>*Have I considered the consequences of all known Undesired Effects?</li> </ul>	<ul style="list-style-type: none"> <li>*Recommend changes that mitigate the risk of causing undesired effects</li> <li>*Create basic branch plans that address enemy reactions and mitigate risks of unintended and undesired effects</li> </ul>	<ul style="list-style-type: none"> <li>*Not get data on adversary</li> <li>*Not "catch" an unintended effect</li> </ul>			<ul style="list-style-type: none"> <li>*The system shall support and aid in the assessment of the likelihood of Undesired Effects occurring given the likely enemy reactions</li> <li>*The system shall provide the history of adversary</li> <li>*The system shall provide information concerning the adversary allies</li> <li>*The system shall provide information concerning adversary capabilities</li> <li>*The system shall provide information concerning</li> </ul>	

## COA Analysis/Wargaming Consulting

Reference Code	#	CWR	IRR	Critical Cue and/or Factors	Critical Decisions	Actions	Common Errors	Tools Used	Communicate with	Data Products used	Requirements
											<p style="text-align: center;">adversaries intent</p> <p>*The system shall aid in determining how might the enemy act to produce Undesired Effects.</p> <p style="text-align: center;">*the system shall aid in considering the consequences of all known Undesired Effects.</p> <p>*The system shall recommend changes that mitigate the risk of causing undesired effects</p> <p>*The system shall create basic branch plans that address enemy reactions and mitigate risks of unintended and undesired effects</p>

## COA Analysis/Wargaming Consulting

Reference Code	#	CWR	IRR	Critical Cue and/or Factors	Critical Decisions	Actions	Common Errors	Tools Used	Communicate with	Data Products used	Requirements
MM1	5	Visualize how operations will unfold based on the selected COA	*COA *Desired effects *Undesired effects *Intentions *History of adversary *Adversary allies *Adversary capabilities *Adversaries intent	*What part of COA is not working	*Determine if COA path is correct *Determine if COA path needs to be modified *Determine if COA will accomplish mission *Determine undesired/desired effects along pathway	*Play COA out from start to end *Evaluate steps within the COA					*The system shall aid in the visualization on how operations will unfold based on the selected COA *The system shall aid in determining if COA path is correct *The system shall aid in determining if COA path needs to be modified *The system shall aid in determining if COA will accomplish mission *The system shall aid in determining undesired/desired effects along pathway

## COA Analysis/Wargaming Consulting

Reference Code	#	CWR	IRR	Critical Cue and/or Factors	Critical Decisions	Actions	Common Errors	Tools Used	Communicate with	Data Products used	Requirements
AFOTTP	6	Ensure COA options attain commanders intent	<ul style="list-style-type: none"> <li>*Commanders Intent</li> <li>*Timing</li> <li>*Deadlines</li> <li>*Resources</li> </ul>		<ul style="list-style-type: none"> <li>*Determine if COAs have measurements that can be collected</li> <li>*Determine COAs meet standards (such as timing)</li> </ul>		<ul style="list-style-type: none"> <li>*Develop COAs that do not have measurements that can be gathered for assessment</li> </ul>				<ul style="list-style-type: none"> <li>*The system shall aid in the comparison of COA options to commanders intent to ensure intent is being met</li> <li>*The system shall aid in determining if COAs are measurable for assessment</li> </ul>
Reg	7	Use previously developed items for analysis	<ul style="list-style-type: none"> <li>*Desired effects</li> <li>*Timing</li> <li>*Prediction of enemy reactions</li> <li>*Unintended effects</li> <li>*Rationale for decisions made</li> </ul>	<ul style="list-style-type: none"> <li>*History of artifacts</li> <li>*Successful / failures</li> </ul>	<ul style="list-style-type: none"> <li>*Determine the need to search for archives</li> <li>*Determine which archives are useful</li> <li>*Determine how to search for archives</li> </ul>	<ul style="list-style-type: none"> <li>*Search for archives</li> <li>*Evaluate archives</li> </ul>	<ul style="list-style-type: none"> <li>*Not know that archives exist</li> <li>*Not know where to find archives</li> <li>*Not able to find archives</li> </ul>			<ul style="list-style-type: none"> <li>*The system shall provide access to archival data concerning past mission</li> <li>*The system shall provide a way to search for archives</li> <li>*The system shall provide a way to archive data</li> <li>*The system shall provide tips on how to search for archives</li> </ul>	

## COA Analysis/Wargaming Consulting

Reference Code	#	CWR	IRR	Critical Cue and/or Factors	Critical Decisions	Actions	Common Errors	Tools Used	Communicate with	Data Products used	Requirements
Reg	8	Build a timeline to identify when certain objectives are projected to occur			*Determine when events should occur  *Determine when events should be complete  *Determine what events precede others						*The system shall aid in building a timeline to identify when certain objectives are projected to occur  *The system shall plot and aid in determining when events should occur  *The system shall plot and aid in determining when events should be complete  *The system shall plot and aid in determining what events precede others
Reg	9	Identify advantages and disadvantages of each COA based on wargaming									*The system shall aid in identifying advantages and disadvantages of each COA based on wargaming

## COA Analysis/Wargaming Consulting

Reference Code	#	CWR	IRR	Critical Cue and/or Factors	Critical Decisions	Actions	Common Errors	Tools Used	Communicate with	Data Products used	Requirements
Reg	10	Refine each COA based on COA wargaming				<p>*Modify each COA based on enemy's most likely and most dangerous reactions based on recommendations, sequel and branch plans</p> <p>*Validate FrOB based on COA wargaming--if better results could be achieved with a different force mix, recommend such a FrOB.</p> <p>*Rank resources according to expected contributions of friendly and adversary forces to achieving desired effects with less risk of failure or greater probability of success</p>					<p>*The system shall allow refinement of each COA</p> <p>*The system shall allow to modification of COAs</p> <p>*The system shall aid in developing enemy's most likely and most dangerous reactions based on recommendations, sequel and branch plans</p> <p>*The system shall aid in validating FrOB based on COA wargaming</p> <p>*The system shall recommend a different force mix.</p> <p>*The system shall aid in and allow the ranking of resources according to expected contributions of friendly and adversary forces to achieving desired effects</p>
AFOTTP	11	Build a timeline to identify when certain tasks (actions) are projected to									<p>*The system shall aid in build a timeline to identify when certain tasks (actions) are projected to occur</p>

## COA Analysis/Wargaming Consulting

Reference Code	#	CWR	IRR	Critical Cue and/or Factors	Critical Decisions	Actions	Common Errors	Tools Used	Communicate with	Data Products used	Requirements
		occur									
AFOTTP	12	Build a timeline to identify when certain effects) are projected to occur									*the system shall aid in building a timeline to identify when certain effects) are projected to occur
AFOTTP	13	Develop a linkage to support a timely and accurate analysis	*Desired effects  *Timing  *Prediction of enemy reactions  *Unintended effects *Rationale for decisions made  *Timeline when objectives, tasks, and effects will take								*The system shall aid in developing linkage(s) to support a timely and accurate analysis

## COA Analysis/Wargaming Consulting

Reference Code	#	CWR	IRR	Critical Cue and/or Factors	Critical Decisions	Actions	Common Errors	Tools Used	Communicate with	Data Products used	Requirements
			place								

## COA Comparison/Selection

Reference Code	#	CWR	IRR	Critical Cue and/or Factors	Critical Decisions	Actions	Common Errors	Tools used	Communicate with	Data Products used	Comments	Requirements
AFOTTP	1	Receive JFACC guidance and objectives										*The system shall allow access to guidance and objectives
AFOTTP	2	Develop guidance	*Objectives *Desired effects	*Adversary behavior *Friendly resources								*The system shall provide the ability to develop guidance and objectives
AFOTTP	3	Develop TO	*Objectives *Desired effects		*Determine and develop objectives that will satisfy overall objectives  *Determine how many objectives are needed	*Attend meeting  *Brainstorm  *Develop TO		*Whiteboard  *Paper  *Word SW	*Other AOC divisions			*The system shall allow generation of Tos  *The system shall provide a template to develop Tos  *The system shall provide a way to save the objectives
AFOTTP	4	Develop MOEs for each TO	*Objectives *Desired effects  *TO		*Determine if measures are collectable  *Determine if measures are "good" measures	*Evaluate measures						*The system shall allow generation of MOEs  *The system shall provide a way to save MOEs  *The system shall provide a way to access old MOEs
AFOTTP	5	Develop OO	*Objectives *Desired effects  *Guidance		*Determine and develop objectives that will satisfy overall objectives  *Determine how many objectives are needed	*Attend meeting  *Brainstorm  *Develop OO		*Whiteboard  *Paper  *Word SW	*Other AOC divisions			*The system shall allow generation of Oos  *The system shall provide a template to develop Oos  *The system shall provide a way to save the objectives

## COA Comparison/Selection

Reference Code	#	CWR	IRR	Critical Cue and/or Factors	Critical Decisions	Actions	Common Errors	Tools used	Communicate with	Data Products used	Comments	Requirements
AFOTTP	6	Develop SI's for each OO	*Objectives *Desired effects *OO		*Determine if the Sis are "good" indicators	*Evaluate Sis						*The system shall allow generation of Sis *The system shall provide a way to save Sis *The system shall provide a way to access old Sis
AFOTTP	7	Develop TT	*Objectives *Desired effects *Resources available *Adversary system information *Friendly system information	*Adversary behaviors *Adversary resources *Adversary intent	*Determine if tasks will achieve objective *Determine risk with tasks *Determine how effective tasks will be *Determine amount of time tasks will take	*Develop tasks *Brainstorm *Attend meeting		*Whiteboard *Paper *Word SW	*Other AOC divisions	*IPB *INSUM / DISUM *TPFDD		*The system shall allow generation of TTs *The system shall allow access to TPFDD *The system shall allow access to Adversary system information (IPB, DISUM, INSUM) *The system shall provide a summary of friendly forces

## COA Comparison/Selection

COA Comparison/Selection												
Reference Code	#	CWR	IRR	Critical Cue and/or Factors	Critical Decisions	Actions	Common Errors	Tools used	Communicate with	Data Products used	Comments	Requirements
AFOTTP	8	Develop MOPs for each TT	*Objectives  *Desired effects  *COA  *Resources Available  *Intent  *Tactical tasks	*Friendly intent  *Friendly resources  *Time	*Determine if measures can be collected  *Determine if measures are "good"  *Determine how long it will take to collect measures	*Develop measures  *Evaluate measures						*The system shall allow generation of MOPs  *The system shall aid in determining if measures can be collected  *The system shall aid in determining if measures are "good"  *The system shall aid in determining how long it will take to collect measures
AFOTTP	9	COA comparison and selection	*Objectives  *Desired effects  *Adversary systems	*Adversary behaviors  *Adversary resources  *Adversary intent	*Determine which COA will best achieve objectives  *Determine which COA produces less risk	*Compare COA  *Rank COA						*The system shall allow comparison of multiple COAs  *The system shall aid in determining which COA will best achieve objectives  *The system shall aid in determining which COA produces less risk  *the system shall allow the comparison of COA  *The system shall allow the ranking of COA

## COA Comparison/Selection

Reference Code	#	CWR	IRR	Critical Cue and/or Factors	Critical Decisions	Actions	Common Errors	Tools used	Communicate with	Data Products used	Comments	Requirements
AFOTTP	10	Evaluate COA analysis / wargaming	*Objectives *Desired effects *Adversary systems									*The system shall provide various methods to analyze multiple COAs
Reg	11	Operational objectives are prioritized	*Objectives *Desired effects *Adversary systems									*The system shall allow operational objectives to be prioritized
Reg	12	Operational objectives are sequenced	*Objectives *Desired effects *Adversary systems									*The system shall allow operational objectives to be sequenced
Reg	13	Operational objectives are phased	*Objectives *Desired effects *Adversary systems									*The system shall allow Operational objectives to be phased

## COA Comparison/Selection

Reference Code	#	CWR	IRR	Critical Cue and/or Factors	Critical Decisions	Actions	Common Errors	Tools used	Communicate with	Data Products used	Comments	Requirements
Reg	14	Operational objectives weight of effort determined	*Objectives *Desired effects *Adversary systems *Resources available							*TPFDD		*The system shall allow Operational objectives weight of effort to be determined
Reg	15	TO are prioritized	*Objectives *Desired effects *Adversary systems									*The system shall allow TO to be prioritized
Reg	16	TO are sequenced	*Objectives *Desired effects *Adversary systems									*The system shall allow TO to be sequenced
Reg	17	TO are phased	*Objectives *Desired effects *Adversary systems									*The system shall allow TO to be phased

## COA Comparison/Selection

COA Comparison/Selection												
Reference Code	#	CWR	IRR	Critical Cue and/or Factors	Critical Decisions	Actions	Common Errors	Tools used	Communicate with	Data Products used	Comments	Requirements
Reg	18	TO weight of effort determined	*Objectives *Desired effects *Adversary systems *Resources available							*TPFDD		*The system shall allow TO weight of effort to be determined
Reg	19	TT are prioritized	*Objectives *Desired effects *Adversary systems									*The system shall allow TT to be prioritized
Reg	20	TT are sequenced	*Objectives *Desired effects *Adversary systems									*The system shall allow TT to be sequenced
Reg	21	TT are phased	*Objectives *Desired effects *Adversary systems									*The system shall allow TT to be phased

## COA Comparison/Selection

Reference Code	#	CWR	IRR	Critical Cue and/or Factors	Critical Decisions	Actions	Common Errors	Tools used	Communicate with	Data Products used	Comments	Requirements
Reg	22	TT weight of effort determined	*Objectives  *Desired effects  *Adversary systems  *Resources available							*TPFDD		*The system shall allow TT weight of effort to be determined

## COA Comparison/Selection

Reference Code	#	CWR	IRR	Critical Cue and/or Factors	Critical Decisions	Actions	Common Errors	Tools used	Communicate with	Data Products used	Comments	Requirements
Reg	23	Determine desired effects	<p>*Priority of effects</p> <p>*Sequencing of effects</p> <p>*Weight of effort</p> <p>*Duration of effect</p> <p>*The location of where effects needs to take place</p>	<p>*Timing aspect of attaining the effects</p> <p>*Priority of effects</p> <p>*Sequencing of effects</p> <p>*Weight of effort</p> <p>*Duration required of effect</p> <p>*Place of effect</p>	<p>*Why do I believe the actions taken will result in the desired effects?</p> <p>*Likelihood effects will attain Objectives (Why do I believe this?)</p> <p>*How will I know when effects are achieved (MOE)</p> <p>*What reaction do I expect from the enemy and why</p> <p>*What Indicators will identify success or failure in attaining the effect(s)</p> <p>*Why do I believe all of the above (rationale)</p>	<p>*Timing aspect of attaining desired effects is provided by focusing the prioritization, sequencing, phasing, and weight of effort, such as to attain them at the time, place and duration required</p>						<p>*The system shall display the priority of effects</p> <p>*The system shall display the sequencing of effects</p> <p>*They system shall display the Weight of effort</p> <p>*The system shall display the duration of effect</p> <p>*The system shall display the location of where effects needs to take place</p>

## COA Comparison/Selection

Reference Code	#	CWR	IRR	Critical Cue and/or Factors	Critical Decisions	Actions	Common Errors	Tools used	Communicate with	Data Products used	Comments	Requirements
Reg	24	Determine potential unintended effects	*Priority of effects *Sequencing of effects *Weight of effort *Duration of effect *The location of where effects needs to take place	*Timing aspect of attaining the effects	*Likelihood of them occurring and why *Impact on JFACC/JFC Objectives (positive and negative) *If negative impacts how can they be avoided *How will I know if/when unintended effects occur with what Indicators *What risk is associated with the unintended effects? Is it acceptable?		*Not receive data in timely manner			*Intel data *Other mission reports		*The system shall aid in determining potential unintended effects
Reg	25	Determine comparison criteria	*Objectives *Desired effects *Adversary systems *Resources available								Criteria usually will be determined by the JFACC, but suggested criteria include risk (of success and of failure), timeliness, and operability	*The system shall aid in determining comparison criteria

## COA Comparison/Selection

COA Comparison/Selection												
Reference Code	#	CWR	IRR	Critical Cue and/or Factors	Critical Decisions	Actions	Common Errors	Tools used	Communicate with	Data Products used	Comments	Requirements
Reg	26	Rate each COA against criteria	*Criteria		*Determine if COA meets criteria							*The system shall allow the ability to rate each COA against the criteria
Reg	27	Recommend highest rated COA	*Criteria *Objectives *Desired effects		*Is there any reason why I should choose a lower-rated COA?  If so, there may be other comparison criteria that should be considered.							*The system shall allow the ability to recommend the highest rated COA
Reg	28	Refine COA based on JFACC/JFC decision and guidance	*Criteria *Objectives *Desired effects *COA *Adversary systems		*Determine how to modify COA	*Modify COA						*The system shall provide the ability to modify COA
	29	Aid in the development of the STTM	*COA adequacy *Forces required *Risk									*The system shall provide the ability to develop the STTM

## COA Comparison/Selection

COA Comparison/Selection												
Reference Code	#	CWR	IRR	Critical Cue and/or Factors	Critical Decisions	Actions	Common Errors	Tools used	Communicate with	Data Products used	Comments	Requirements
			*Time *Completeness *Feasibility *Probability									

## COA Development

Reference Code	#	CWR	IRR	Critical Cue and/or Factors	Critical Decisions	Actions	Common Errors	Tools used	Communicate with	Data Products used	Comments	Requirements
MM1	1	Plan or sequence of action is how the goal or objective is going to be accomplish	*Objectives  *Desired effects  *Adversary systems  *Friendly systems  *Resources available	*Adversary behavior  *Adversary intent  *Adversary resources	*Determine if sequence of actions will effectively achieve objective  *Determine if an "event" needs to be modified to better achieve objectives	*Modify plan					*The system shall provide a plan or sequence of actions needed to achieve the goal  *The system shall provide a way to modify plan	
Reg	2	Analyze and identify friendly COGs	*COG Critical capabilities  *COG Critical requirements  *COG Critical Vulnerabilities  *Fielded forces  *Infrastructures		*Determine if COG is friendly or hostile						*The system shall provide the ability to analyze and identify friendly COGs  *The system shall provide the ability to identify COG Critical capabilities  *The system shall provide the ability to identify COG Critical requirements  *The system shall provide the ability to identify COG Critical Vulnerabilities	

## COA Development

COA Development												
Reference Code	#	CWR	IRR	Critical Cue and/or Factors	Critical Decisions	Actions	Common Errors	Tools used	Communicate with	Data Products used	Comments	Requirements
			*Moral  *Political									
Reg	3	Develop Effects (desired and undesired)	*Objectives  *Desired effects  *Adversary systems  *Friendly systems  *Resources available		*Why do I believe these effects will attain the operational objectives  *How will these effects support attaining the objectives?  *How will I know these effects have been achieved?  *Why do I believe these effects will occur?  *Will these other effects add to or subtract from	*Assess the likelihood of the desired effects attaining the objective. This requires an understanding of the cause and effect relationship.  *Recommend success indicators (MOEs) that will aid in assessment of desired effects (ISR Strategy and planning—third pillar of PBA)					*The system shall provide the capability to assess the likelihood of the desired effects attaining the objective.  *The system shall provide the capability to recommend success indicators (MOEs) that will aid in assessment of desired effects (ISR Strategy and planning—third pillar of PBA)  *The system shall provide the capability to Determine potential unintended effects  *The system shall provide the capability to Assess the likelihood of all unintended effects occurring? Assess the impact, or value, of the unintended effects with respect to the JFACC's and the JFC's objectives  *The system shall provide the capability to Recommend indicators that will aid in assessment of unintended effects (ISR)	

## COA Development

Reference Code	#	CWR	IRR	Critical Cue and/or Factors	Critical Decisions	Actions	Common Errors	Tools used	Communicate with	Data Products used	Comments	Requirements
					<p>accomplishing the objectives?</p> <p>*How can I avoid undesired effects?</p> <p>Can I modify the action or take some other action in addition to the original action?</p> <p>*How will I know when unintended effects have occurred?</p> <p>*Why do I believe these effects will attain the tactical objectives?</p> <p>*How will the actions support achieving these effects?</p>	<p>*Determine potential unintended effects</p> <p>*Assess the likelihood of all unintended effects occurring?</p> <p>Assess the impact, or value, of the unintended effects with respect to the JFACC's and the JFC's objectives</p> <p>*In cases where the impact is counterproductive, recommend actions that might mitigate the risk of undesired effects</p> <p>*Recommend indicators that will</p>					<p>Strategy and planning—third pillar of PBA)</p> <p>*The system shall provide the capability to Determine the tactical objectives that will accomplish operational objectives. Determine desired effects (direct and indirect) that will achieve objectives</p> <p>*The system shall provide the capability to Assess the likelihood of the desired effects attaining the objective. This requires an understanding of the cause and effect relationship (causal linkage)</p> <p>*The system shall provide the capability to Determine supporting actions/tasks</p> <p>*The system shall provide the capability to Refine COAs based on priority, sequence, phasing, weight of effort, and matched resources</p> <p>*The system shall provide the capability to Ensure Phases (and objectives) support JFC phasing, objectives, and end state</p> <p>*The system shall provide the capability to Sequence Tasks (Actions) to accomplish objectives and to</p>	

## COA Development

Reference Code	#	CWR	IRR	Critical Cue and/or Factors	Critical Decisions	Actions	Common Errors	Tools used	Communicate with	Data Products used	Comments	Requirements
						<p>aid in assessment of unintended effects (ISR Strategy and planning—third pillar of PBA)</p> <p>*Determine the tactical objectives that will accomplish operational objectives. Determine desired effects (direct and indirect) that will achieve objectives</p> <p>*Assess the likelihood of the desired effects attaining the objective. This requires an understanding of</p>						<p>*The system shall provide the capability to identify risk areas for each COA</p>

## COA Development

COA Development											
Reference Code	#	CWR	IRR	Critical Cue and/or Factors	Critical Decisions	Actions	Common Errors	Tools used	Data Products used	Comments	Requirements
						the cause and effect relationship (causal linkage)  *Determine supporting actions/tasks  *Refine COAs based on priority, sequence, phasing, weight of effort, and matched resources  *Ensure Phases (and objectives) support JFC phasing, objectives, and end state  *Sequence Tasks (Actions) to accomplish objectives and to  *Identify risk areas					

## COA Development

COA Development												
Reference Code	#	CWR	IRR	Critical Cue and/or Factors	Critical Decisions	Actions	Common Errors	Tools used	Communicate with	Data Products used	Comments	Requirements
						for each COA						

Reference Code	#	CWR	IRR	Critical Cue and/or Factors	Critical Decisions	Actions	Common Errors	Communicate with	Data Products used	Comments	Requirements
AFOTTP	1	Develop air and space assessment measures for assessing JFACC objectives and tasks during execution	<ul style="list-style-type: none"> <li>*JFACC objectives</li> <li>*JFACC tasks</li> <li>*Resources that will perform missions</li> <li>*Adversary history</li> <li>*Desired effects</li> <li>*Undesired effects</li> </ul>		<ul style="list-style-type: none"> <li>*Determine assessment measures</li> </ul>	<ul style="list-style-type: none"> <li>*Develop assessment measures</li> </ul>					<ul style="list-style-type: none"> <li>*The system shall support in developing assessment measures for missions</li> </ul>
MM1	2	What, where, how joint force will affect the enemy or the situation at hand	<ul style="list-style-type: none"> <li>*COA</li> <li>*Resources being used</li> <li>*Adversary capabilities</li> <li>*Adversary intentions</li> </ul>	<ul style="list-style-type: none"> <li>*Area surroundings</li> <li>*Buildings located in space</li> <li>*Other environmental features in area</li> </ul>	<ul style="list-style-type: none"> <li>*Determine the effectiveness of the COA in terms of specified measures that meet the objectives and guidance</li> </ul>						<ul style="list-style-type: none"> <li>*The system shall aid in the prediction of events that may occur during a COA (play out)</li> <li>*The system shall provide a graphical representation of the area</li> <li>*The system shall have access to adversary data</li> </ul>
MM1	3	Determine end state ---what is to be accomplished,	<ul style="list-style-type: none"> <li>*Desired effects</li> <li>*Undesired effects</li> </ul>		<ul style="list-style-type: none"> <li>*Determine which COA will best accomplish the end state</li> </ul>						<ul style="list-style-type: none"> <li>*The system shall provide a means to input end states and aid in the development of COAS to achieve end state</li> </ul>

**Coordinate with ISRD**

Reference Code	#	CWR	IRR	Critical Cue and/or Factors	Critical Decisions	Actions	Common Errors	Communicate with	Data Products used	Comments	Requirements
MM1	4	Determine the purpose or rationale provide why the goal is sought			*Determine what rational/goal is						*The system shall provide access to or a way to input the purpose or rationale as to why the goal is sought
MM1	5	Determine the plan or sequence of actions of how the goal or objective is going to be accomplished	*Adversary systems  *Friendly systems	*Weather  *Geography	*Determine the sequence of actions to achieve goal	*Develop plan(s)					*The system shall provide visually, a plan or sequence of actions on how the goal or objective is going to be accomplished  *The system shall provide access to environmental information such as weather.
MM1	6	Specify the resources for the plan	*Resources available  *SPINS or other rules		*Determine the "best" resource for a particular task	*Allocate resources to tasks	*Not have updated TPFID		TPFID		*The system shall display a listing of available resources for the plan (e.g. TPFID)
	8	Determine info required to support OA	*Types of information available  *"Who" and "how" will the information be gathered	*Time  *Accuracy  *Reliability	*Determine the types of information needed for assessment, and when the information is needed  *Determine who to ask for the information needed	*Request for information					*The system shall aid in determining what info is required to support OA  *The system shall allow the user to request information

## Coordinate with Special Technical Ops

Reference Code	#	CWR	IRR	Critical Cue and/or Factors	Critical Decisions	Actions	Common Errors	Tools used	Communicate with	Data Products used	Comments	Requirements
	1	Identify who you need to communicate with	*Mission  *Need to know who (positions) are needed to be part of your team  *Need to know how to get in contact with team members	*Location of team members  *Criticality of communications	*Decide on priorities of communications with various team members	*Contact team members to join communications	*Not contact or know if a critical team member	*COMMS (phone, red phone)  *Email  *Chat		*Org chart		*The system shall provide access to mission  *The system shall provide a list of team members  *The system shall provide a means to contact team members
	2	Choose proper communication mode	*Need to know what comms are working/not working  *Need to know the "best" comm mode for current job  *Need to know	*Various comm methods	*Decide on working status of comms  *Decide what the best comm mode is for the job		*Choose wrong comm mode for mission  *Choose a comm that is not working properly  *Choose a comm mode	*Comm modes				*The system shall provide various communication pathways  *The system shall provide ways to test comms  *The system shall provide a diagnosis of comms  *The system shall aid in the decision making of choosing a comm mode for mission

## Coordinate with Special Technical Ops

Reference Code	#	CWR	IRR	Critical Cue and/or Factors	Critical Decisions	Actions	Common Errors	Tools used	Communicate with	Data Products used	Comments	Requirements
			alternative comm pathways				that does not work for every team members					*The system shall display various communication pathways
	3	Ensure communication pathway is working	*Need to know how to test comms *Need to know procedures to test COMMS status *Need to know how to fix comms if not working properly	*Noise / no noise *No response	*Decide on best method to test comms *Decide on best method to fix comms	*Fix comms *Test comms	*Not test properly *Not know how to fix *Misdiagnose the problem					*The system shall provide methods to test comms *The system shall provide a diagnosis of problems with comms *The system shall provide checklists on how to fix problem

## Coordinate with Special Technical Ops

Reference Code	#	CWR	IRR	Critical Cue and/or Factors	Critical Decisions	Actions	Common Errors	Tools used	Communicate with	Data Products used	Comments	Requirements
	4	Ensure team members are using same pathway	*Need to know if team members are "hooked" into the correct comm pathway  *Need to know who is part of your team  *Need to know who you need to communicate with	*No response								*The system shall provide status of who is on-line  *The system shall provide a team summary
	5	Ensure a second comm method is chosen	*Need to know what the next best method for communication is  *Need to ensure comm is working	*Type of mission  *Team responsiveness to particular comms	*Decide on best comm method  *Decide if comm is working properly		*Choosing bad comm method					*The system shall provide listings of various comm modes

## Coordinate with Special Technical Ops

Reference Code	#	CWR	IRR	Critical Cue and/or Factors	Critical Decisions	Actions	Common Errors	Tools used	Communicate with	Data Products used	Comments	Requirements
	6	Set up communication pathway	<p>*Need to know how to set up communication pathway</p> <p>*Need to know how to alert team members what the comm pathway is</p> <p>*Need to know how to set up comms so the constant comms can be running</p>				<p>*Set comm pathway up wrong</p> <p>*Not alert team members what pathway is</p>					<p>*The system shall enable users to set up comm pathways</p> <p>*The system shall allow a alerts to let team members know what the comms pathway being used is</p>
	7	Coordinate with team concerning where and how often data / information will be stored or sent	*Know available places to store information				Communicate the wrong information,					*The system shall allow storage of information in a database

**Develop Diagnostic Assessment**

Reference Code	#	CWR	IRR	Critical Cue and/or Factors	Critical Decisions	Actions	Common Errors	Tools used	Communicate with	Data Products used	Requirements
	1	Generate options and recommendation for strat division consideration	*Plan  *Desired effects	*Unmeasurable COA	*Determine when a modification to the plan needs to be made	*Suggest changes with alternatives			Strat Team		*The system shall provide a means to develop options to strat plans and compare courses
	2	Compare actual to expected results for tactical tasks	*Desired effects  *Undesired effects  *Unintended effects  *Mission failures/successes	*Adversary behavior	*Determine if plan was successful	*Compare plan vs. actual events				Intel data	*The system shall allow the comparison of actual to expected results for tactical tasks

## Develop Diagnostic Assessment

Develop Diagnostic Assessment											
Reference Code	#	CWR	IRR	Critical Cue and/or Factors	Critical Decisions	Actions	Common Errors	Tools used	Communicate with	Data Products used	Requirements
	4	Identify reasons for shortfalls	*Mission  *COA  *Desired effects  *Undesired effects  *Unintended effects  *Adversary behavior  *Mission successes/failures  *WOE	*Adversary behavior  *Mission failures reasoning	*Determine what the shortfalls are  *Determine a way to overcome shortfalls  *Determine if a modification to the plan is needed	*Identify shortfalls  *Make recommendation					*The system shall identify shortfalls in missions and plans  *The system shall support the decision making of overcoming the shortfalls  *The system shall aid in determining if a modification to the plan is needed

## Develop Diagnostic Assessment

Develop Diagnostic Assessment											
Reference Code	#	CWR	IRR	Critical Cue and/or Factors	Critical Decisions	Actions	Common Errors	Tools used	Communicate with	Data Products used	Requirements
	5	Assess feasibility of corrective actions	*Resources available  *Actual vs Plan  *WOE for each objective  *Time needed for each objective  *Priorities	*WOE  *Time	*Determine if resources available for corrective actions  *Determine amount of change to plan, and what to change  *Determine WOE for each objective  *Determine the time needed to achieve each objective  *Determine priorities for next day according to actual vs planned	*Make recommendation				TPFID	*The system shall aid in and allow the assessment of the feasibility of the corrective actions  *The system shall determine if resources are available for corrective actions  *The system shall determine amount of change to plan, and what to change  *The system shall determine the WOE for each objective  *The system shall determine the time needed to achieve each objective  *The system shall determine the priorities for next day according to actual vs planned

**Develop Diagnostic Assessment**

Develop Diagnostic Assessment											
Reference Code	#	CWR	IRR	Critical Cue and/or Factors	Critical Decisions	Actions	Common Errors	Tools used	Communicate with	Data Products used	Requirements
	6	Predict effects of corrective actions on tactical and operational objectives	*Resources available  *Actual vs Plan  *WOE for each objective  *Time needed for each objective  *Priorities  *Intended effects	*Adversary systems  *Friendly systems	*Determine if corrective actions will produce undesired effects and desired effects	**Play" out COA				TPFID	*The system shall allow and aid in the prediction of effects of the corrective actions on tactical and operational objectives  *The system shall allow and aid in the prediction of the effects that the corrective actions on tactical and operational objectives will have

## Develop Diagnostic Assessment

Develop Diagnostic Assessment											
Reference Code	#	CWR	IRR	Critical Cue and/or Factors	Critical Decisions	Actions	Common Errors	Tools used	Communicate with	Data Products used	Requirements
	7	Rank potential corrective actions	<ul style="list-style-type: none"> <li>*Intended effects</li> <li>*Objectives</li> <li>*Priorities</li> <li>*Adversary and friendly systems</li> <li>*Resources available</li> </ul>	<ul style="list-style-type: none"> <li>*Environmental conditions</li> <li>*Adversaries current status</li> <li>*Risk</li> </ul>	<ul style="list-style-type: none"> <li>*Determine which plan will "best" accomplish objectives/effects</li> <li>*Determine which plan has less risk associated with it</li> </ul>						<ul style="list-style-type: none"> <li>*The system shall determine which plan will "best" accomplish objectives/effects</li> <li>*The system shall determine which plan has less risk associated with it</li> </ul>
	8	Communicate corrective actions to plans team	<ul style="list-style-type: none"> <li>*Know who to send modifications to</li> <li>*Know proper format of recommendations</li> <li>*Know what information to put in report</li> <li>*Know how to send report out</li> </ul>		<ul style="list-style-type: none"> <li>*Determine when to give report</li> <li>*Determine what information to put in the report</li> <li>*Determine how long the report should take</li> </ul>	*Communicate the report		Power Point			<ul style="list-style-type: none"> <li>*The system shall allow and aid in the selection of one or more corrective actions</li> <li>*The system shall provide a template for reports</li> <li>*The system shall allow and aid in the communication of the corrective actions to the plans team</li> </ul>

**Develop Diagnostic Assessment**

Develop Diagnostic Assessment											
Reference Code	#	CWR	IRR	Critical Cue and/or Factors	Critical Decisions	Actions	Common Errors	Tools used	Communicate with	Data Products used	Requirements
	10	Identify unanticipated operational limitations	*Resources available  *Actual vs Plan  *WOE for each objective  *Time needed for each objective  *Priorities  *Intended effects	*Changes in priorities  *Changes in objectives WOE  *Changes in resource availability	*Determine what limitations will have on achieving overall effect   *Determine how to overcome limitations						*The system shall aid in determining what limitations will have on achieving overall effect  *The system shall aid in determining how to overcome limitations

## Develop Overall OA Plan

Develop Overall OA Plan											
Reference Code	#	CWR	IRR	Critical Cue and/or Factors	Critical Decisions	Actions	Common Errors	Tools used	Communicate with	Data Products used	Requirements
AFOTTP	1	Develop an overall Operational Assessment plan to evaluate both JAOP planning and actual execution of joint air operations									*The system shall provide the ability to develop an OA plan  *The system shall provide the ability to compare and evaluate the OA plan against the JAOP  *The system shall provide the ability to evaluate OA in real time. during execution  *The system shall provide the ability to modify the OA plan in real time  *The system shall aid in the decision making of where and how the plan should be modified
AFOTTP	2	Build contact list showing links and impacts of specific key organizations on the OA process									*The system shall provide the capability to develop team member list(s)

Develop Overall OA Plan											
Reference Code	#	CWR	IRR	Critical Cue and/or Factors	Critical Decisions	Actions	Common Errors	Tools used	Communicate with	Data Products used	Requirements
AFOTTP	3	Develop an Operational Assessment plan for the JAOC	Plan includes:  *Evaluation of JAOP planning and execution that includes multiple sources  *Collection strategies, and procedures for gathering and exploiting enemy intelligence and friendly information (ISR, IO, space, operations, logistics, comms)		*Determine best collection strategies for mission(s)	*Develop plan  *Distribute plan					*The system shall allow for the creation of an assessment plan
	4	Integrate JFC and JFACC OAs				*Integrate JFC and JFACCs OA's into the plan					*The system shall allow the integration of both JFC and JFACC OAs
	5	Evaluate air, space, and IO effectiveness and efficiency			*Determine effectiveness and efficiency of plans  *Determine if changes need to be made to plans	*Review and evaluate plans			*Air Component  *Space Component		*The system shall allow for and support the evaluation of air, space, and IO effectiveness and efficiency
AFOTTP	6	Establish relationships, contacts to integrate functional JAOC	*Know who is part of the process	*Experience of individuals  *Individuals	*Determine who is an integral team member	*Make contacts			*Strat Team		*The system shall allow and support the capability to share information among team members  *The system shall allow and support the capability to

Develop Overall OA Plan											
Reference Code	#	CWR	IRR	Critical Cue and/or Factors	Critical Decisions	Actions	Common Errors	Tools used	Communicate with	Data Products used	Requirements
		activities into OA process	*Know what roles each person plays  *Know chain of command	knowledge of mission  *Amount of time in the area					*ISR		integrate data received from team members into the overall OA plan
AFOTTP	7	Determine assessment information requirements									*The system shall support and allow the development of assessment information requirements
AFOTTP	8	Evaluate the effectiveness of JFACC objectives in supporting JFC objectives	*JFC Objectives  *Resources available  *Credibility and reliability of products and their information	*Strength of support	*Determine each products effectiveness in supporting the overall campaign	Review:  *JAOP  *MAAP  *ATO  *Weapon eered Source JIPTL  *OPLAN	*Not receive data that is needed to do an effective evaluation			*JAOP  *MAAP  *ATO  *Weapon eered Source JIPTL  *OPLAN	*The system shall support evaluation of JFACC objectives  *The system shall allow access to JAOP, MAA, ATO, JIPTL, and OPLAN  *The system shall allow the ability to request the: JAOP, MAA, ATO, JIPTL, and OPLAN  *The system shall aid in the decision making and evaluation between product and objectives
AFOTTP	9	Identify and establish definitive linkages to any information or intel sources that can support combat and Operational Assessment functions within the JAOC	*Types of information available	*What is actually available to the team directly / indirectly	*Determine which sources are important / not important	*Create/set up linkages	*Not identify or know that an important link exists				*The system shall support and aid in the identification and establishment of any definitive linkages to information or intel sources that can support combat and Operational Assessment functions within the JAOC

## Develop Overall OA Plan

Develop Overall OA Plan											
Reference Code	#	CWR	IRR	Critical Cue and/or Factors	Critical Decisions	Actions	Common Errors	Tools used	Communicate with	Data Products used	Requirements
AFOTTP	10	Refine standard operation procedures specific to individual duties and responsibilities	<ul style="list-style-type: none"> <li>*Know duties and responsibilities associated with a role</li> <li>*Know roles needed for mission(s)</li> <li>*Know the SOP for each role</li> </ul>	<ul style="list-style-type: none"> <li>*Individual experience</li> <li>*Workload</li> <li>*Time frame</li> </ul>	<ul style="list-style-type: none"> <li>*Determine who will be assigned to what role</li> <li>*Determine how many tasks to give to one individual</li> </ul>	<ul style="list-style-type: none"> <li>*Assign roles and responsibilities</li> <li>*Assign SOP to individuals</li> </ul>	<ul style="list-style-type: none"> <li>*Not know if role is needed</li> <li>*Misassign responsibility</li> <li>*Not assign a responsibility</li> <li>*Not know of all SOPs</li> </ul>				<ul style="list-style-type: none"> <li>*The system shall allow for the refinement of standard operation procedures specific to individual duties and responsibilities</li> <li>*The system shall allow assignment of SOP to individuals</li> <li>*The system shall allow assignment of roles and responsibilities to individuals</li> <li>*The system shall aid in the identification of SOPs, roles, and responsibilities</li> </ul>
AFOTTP	11	Determine information requirements associated with assessments	<ul style="list-style-type: none"> <li>*Adversary information</li> <li>*Past mission information</li> <li>*Current mission information</li> <li>*Overall objectives</li> </ul>	<ul style="list-style-type: none"> <li>*Type of mission</li> <li>*Objectives</li> <li>*Time frame to achieve objectives</li> </ul>	<ul style="list-style-type: none"> <li>*Determine critical information requirements</li> <li>*Prioritize information requirements</li> </ul>		<ul style="list-style-type: none"> <li>*Not identify a information requirement</li> <li>*Not receive information</li> </ul>				<ul style="list-style-type: none"> <li>*The system shall allow input for and aid in the determination of information requirements associated with assessments</li> </ul>
AFOTTP	12	Obtain information or intel to support OA	<ul style="list-style-type: none"> <li>*Know where data may exist</li> <li>*Know proper division to ask for the various types of data</li> </ul>		<ul style="list-style-type: none"> <li>*Determine "best" type of intel data to be used</li> </ul>	<ul style="list-style-type: none"> <li>*Receive data</li> </ul>	<ul style="list-style-type: none"> <li>*Not have access to data</li> <li>*Data does not exist</li> </ul>		ISR D		<ul style="list-style-type: none"> <li>*The system shall allow the team to obtain and request information or intel</li> </ul>

## Develop Overall OA Plan

Develop Overall OA Plan											
Reference Code	#	CWR	IRR	Critical Cue and/or Factors	Critical Decisions	Actions	Common Errors	Tools used	Communicate with	Data Products used	Requirements
AFOTTP	13	Integrate OA from JFACC with its counterparts at the JFC level to ensure a cohesive picture between the campaign plan and the air and space portion of that campaign				<p>*During OIF, a senior Operational Assessment analyst was imbedded into the JFC's Campaign Operations Assessment Board in the J8 staff. This facilitated communication and synchronization of assessment activities up through HHQ.</p> <p>*Integrate air and space component OA with JFC counterparts</p>				<p>*Air reports</p> <p>*Space Reports</p>	<p>*The system shall allow the integration of the OA from JFACC with its counterparts at the JFC level</p> <p>*The system shall aid in the assessment of the OA Plan to ensure a cohesive picture between the campaign plan and the air and space portion of that campaign</p>
AFOTTP	14	Determine risk	<p>*COAs</p> <p>*Desired effects</p>		<p>*Determine loss</p> <p>*Determine cost</p> <p>*Determine if COA is routine or not</p> <p>*Ensure that standards for routine events are adequate to provide an acceptable level of risk.</p>	*Perform analysis / evaluation					<p>*The system shall aid and support in determining loss</p> <p>*The system shall aid and support in determining cost</p> <p>*The system shall aid and support in determining if COA is routine or not</p> <p>*The system shall aid and support in ensuring that standards for routine events are adequate to provide an acceptable level of risk.</p>

## Develop Overall OA Plan

Develop Overall OA Plan											
Reference Code	#	CWR	IRR	Critical Cue and/or Factors	Critical Decisions	Actions	Common Errors	Tools used	Communicate with	Data Products used	Requirements
AFOTTP	15	Determine benefits of plan	*Risks  *Objectives  *Know available controls to reduce risk	*Plan does not meet objectives	*Determine if plans meet objectives  *Determine if benefits outweigh risks  *Determine what factors can be used to control risk	*Balancing risk vs benefits  *Eliminate unnecessary risks.  *Reduce the magnitude of mission essential risks by applying controls	*Underestimate risk				*The system shall allow and aid in the balancing of risk vs benefits  *The system shall aid in and allow to eliminate unnecessary risks.  *The system shall aid in an allow to reduce the magnitude of mission essential risks by applying controls
AFOTTP	16	Review and refine plan			*Determine decision points where the commander is required by the higher guidance to formally assess progress and consider adjusting the plan  *Determine if lack of effects achievement is due to inappropriate actions or monitoring wrong MOE	*Evaluate roles and responsibilities of components, coalition members, and the DIE agencies in the EBA process  *Evaluate intelligence collection requirements  *Evaluate battle rhythm to track and continuously review the MOE and MP  *Evaluate methodology to examine areas of progress, lack of progress, and causality					*The system shall allow for the evaluation of roles and responsibilities of components, coalition members, and the DIE agencies in the EBA process  *The system shall allow for the evaluation of intelligence collection requirements  *The system shall allow for the evaluation of battle rhythm to track and continuously review the MOE and MP  *The system shall allow for the evaluation of methodology to examine areas of progress, lack of progress, and causality  *The system shall for the evaluation of the methodology to determine whether lack of effects achievement is due to inappropriate actions or monitoring wrong MOE

Develop Overall OA Plan												
Reference Code	#	CWR	IRR	Critical Cue and/or Factors	Critical Decisions	Actions	Common Errors	Tools used	Communicate with	Data Products used		Requirements
						*Evaluate methodology to determine whether lack of effects achievement is due to inappropriate actions or monitoring wrong MOE						

ISRD												
Reference Code	#	CWR	IRR	Critical Cue and/or Factors	Critical Decisions	Actions	Common Errors	Tools used	Communicate with	Data Products used	Comments	Requirements
AFOTTP	1	ISRD provide assessment of IPB, adversary COAs, COGs, Targeting, and ISR operations	*Adversary Activity  *Adversary status in battlespace  *Analysis on how ISR determined strategic/operational advantage and instantiate over the adversary  *Level of success achieved by the ACF at acquiring, defining, and	*Adversary strategy  *Adversary intention  *Adversary desired end state  *Adversary perception of friendly	*Are ACFs predictions of adversary behavior valid?  *Are ISR's (ACF's and Targets/CA's) estimate of adversary COGs still valid?  *Determine effectiveness of the ACF sections of the JAOP, AOD, RSTA Annex in terms of objective	Provide recommendations to modify strategy to better accomplish JFC/JFACC objectives and desired effects		PowerPoint	ISRD-personnel expertise  ----ACF Strategist  ----Targets strategist  ----ISR ops Strat	*ACF Operational assessment documents (briefings, reports)		*The system shall provide access to IPB assessment  *The system shall provide adversary COAs *The system shall provide access to COG information  *The system shall provide targeting information  *The system shall provide access to ISR operations

**ISR**

<b>ISR</b>												
Reference Code	#	CWR	IRR	Critical Cue and/or Factors	Critical Decisions	Actions	Common Errors	Tools used	Communicate with	Data Products used	Comments	Requirements
			closing gaps in the PB	Vulnerabilities  *Adversary intentions	and task accomplishment, adherence or divergence from the established plan, and optimum use of available resources							*The system shall provide information concerning adversary activity  *The system shall provide information on adversary status in battlespace  *The system shall access to ACF information  *The system shall provide adversary intentions  *The system shall provide adversary strategies  *The system shall provide adversary end state  *The system shall provide adversary "Cultural" information

**ISR D**

ISR D												
Reference Code	#	CWR	IRR	Critical Cue and/or Factors	Critical Decisions	Actions	Common Errors	Tools used	Communicate with	Data Products used	Comments	Requirements
AFOTTP	2	Targeting specialist provides targeting expertise to the OA process	*Timeliness and formatted CA ---BDA, MEA, MA (portions)			*Review BDA/MEA summaries	*Not get information in timely manner		Targeting Strategist	ISR uses  *BDA  *MEA  *MA	TS serves as the link between the CA cell in the ISR D and the OAT	*The system shall provide access to CA  *The system shall provide access to BDA  *The system shall provide access to MEA  *The system shall provide access to MA  *The system shall provide comms between OAT and Targeting specialist  *The system shall provide updates of status of CA, BDA, MEA, and MA
AFOTTP	3	Evaluate targeting strategy for effectiveness in meeting JFC/JFACC objectives and desired effects	*JFC/JFACC Objectives  *JFC/JFACC Desired Effects  *Targeting strategy	*Desired effects  *Undesired effects	*Determine effectiveness of targeting strategy compared to JFC/JFACC guidance	*Evaluate targeting strategy	*Miss critical information  *Incorrectly interpret information		Targeting Strategist	*Targeting strategy report		*The system shall provide access to JFC/JFACC objectives, and desired effects  *The system shall provide access to targeting strategy  *The system shall provide views to compare objectives, and desired effects to targeting strategy

## ISR D

ISR D												
Reference Code	#	CWR	IRR	Critical Cue and/or Factors	Critical Decisions	Actions	Common Errors	Tools used	Communicate with	Data Products used	Comments	Requirements
AFOTTP	4	Promulgate targeting strategy for effectiveness in meeting JFC/JFACC objectives and desired effects	*JFC/JFACC Objectives  *JFC/JFACC Desired Effects  *Know who to promulgate strategy to	*Ways to promulgate strategy	*Decide when strategy is ready  *Decide who needs to know	*Promulgate to proper teams	*Not ensuring that OAT requirements are clearly stated and understood		Targeting Strategist			*The system shall provide the capability to develop a targeting strategy  *The system shall provide a means to promulgate plan to team
AFOTTP	5	Review BDA/MEA summaries to ensure BDA/MEA is factored into MA, future target development / nomination and OA	*MA  *Target information  *Operational Assessment		*Ensuring that BDA/MEA is factored into MA, target dev/nom and OA	*Ensure that BDA/MEA is factored in			Targeting Strategist	ISR uses  *BDA  *MEA		*The system shall provide the capability to compare BDA/MEA to MA to ensure accuracy
AFOTTP	6	Evaluate BDA results for unintended effects	*Intended effects  *Desired effects  *Adversary capabilities	*Mission failure  *Adversary behavior  *Adversary capabilities	*Determine unintended effects	*Evaluate BDA	*Misinterpret information  *Not receive data in timely manner  *Not receive data		Targeting Strategist	BDA		*The system shall provide the capability to evaluate BDA for effects  *The system shall provide data to mission success, failures, shortcomings  *The system shall provide access to adversary history, capabilities, resources, and intentions  *The system shall provide ways to update team on status of BDA

## ISR D

ISR D												
Reference Code	#	CWR	IRR	Critical Cue and/or Factors	Critical Decisions	Actions	Common Errors	Tools used	Communicate with	Data Products used	Comments	Requirements
AFOTTP	7	Make re-attack recommendations	*Operational level objectives  *Mission success  *Mission failures  *Mission shortcoming  *Priorities  *Objectives  *Desired effects	*Actual effects  *Resources available  *Timing  *Undesired effects	*Determine if re-attack is needed	*Make recommendation			Targeting Strategist			*The system shall provide means to make a re-attack recommendation
AFOTTP	8	ISR ops strat and OAT work with ISR ops teams and PED Management team to obtain JAOC ISR operations assessment and refining subsequent JFACC ISR strategy	*JAOC operations assessment  *JFACC ISR strategy		*Determine what to refine and how to refine it.				*ISR Ops Strategist  *PED Management  *ISR Ops Teams			
AFOTTP	9	Assesses the results of TPED (Tasking, Processing, Exploitation, and Dissemination)	*Need to have TPED data	*Results vs planned  *Mission accomplished vs not accomplished  *Adversaries behaviors	*Determine what TPED indicates	*Evaluate TPED	*Incorrectly evaluate		ISR Ops Strategist	TPED		*The system shall provide access to TPED

## ISR D

ISR D												
Reference Code	#	CWR	IRR	Critical Cue and/or Factors	Critical Decisions	Actions	Common Errors	Tools used	Communicate with	Data Products used	Comments	Requirements
AFOTTP	10	Refine the ISR strategy	*ISR Strategy  *Mission  *OO  *TO  *TT		*Determine what changes to make to strategy	*Make modifications to ISR strategy			ISR Ops Strategist			*The system shall provide access to ISR strategy  *The system shall allow modifications to ISR strategy
AFOTTP	11	Measure mission operational factors	*Platform  *Sensor  *Crew  *Link issues  *Target deck satisfaction	*Resources down  *Resources unavailable  *Effectiveness					ISR Ops Strategist			
AFOTTP	12	MOEs to determine if PIRs/ISR tasks are being answered	*MOEs  *PIR/ISR Tasks						*ISR Ops Strategist  *ACF  *Targets Strategist			*The system shall provide access to PIR/ISR tasking
AFOTTP	13	Receive ISR input to the OAT plan to evaluate JAOP planning and execution	*ISR Reports	*BDA  *Effects					ISR Ops Strategist			

## ISR D

ISR D												
Reference Code	#	CWR	IRR	Critical Cue and/or Factors	Critical Decisions	Actions	Common Errors	Tools used	Communicate with	Data Products used	Comments	Requirements
AFOTTP	14	Evaluate the ISR strategy for effectiveness in meeting overall ISR requirements, JFC/JFACC PIRs and supporting JFC/JFACC strategy and plans			*Determine if ISR strategy meets all of the requirements	*Evaluate ISR strategy			ISR Ops Strategist			*The system shall provide a means to evaluate ISR strategy by evaluating it against PIRs, strategies, and plans
AFOTTP	15	Monitor the ISR strategy for effectiveness in meeting overall ISR requirements, JFC/JFACC PIRs and supporting JFC/JFACC strategy and plans				*Monitor ISR strategy			ISR Ops Strategist			*The system shall provide the ability to monitor ISR objectives
AFOTTP	16	Receive ISR report on sections of the JAOP and AOD and RSTA Annex effectiveness	*Objective  *Task accomplishment  *Adherence  *Divergence from the established plan  *Optimum use of available resources			*Receive report			ISR Ops Strategist	*ISR Report		*The system shall provide access to ISR report
AFOTTP	17	Receive ISR operations assessment documentation				*Receive report			ISR Ops Strategist	*ISR documentation		*The system shall provide access to ISR documentation

## ISR D

ISR D												
Reference Code	#	CWR	IRR	Critical Cue and/or Factors	Critical Decisions	Actions	Common Errors	Tools used	Communicate with	Data Products used	Comments	Requirements
AFOTTP	18	Receive data from operations and operational results	*ISR platform *Distributed PED performance  *Problems and limitations  *Collection satisfaction for pre-planned collection decks  *Timeliness  *Operational effectiveness/success of time sensitive collection re-taskings	*Successes / failures  *Effects (desired, undesired, unanticipated)		*Receive data	*Not receive data		ISR Ops Strategist	*SITREPS  *MISREPS  *Other reports		*The system shall provide access to multiple sources of reports
AFOTTP	19	Receive data if PIR is answered	*If the PIR is partially answered  *If the PIR is not answered  *Rational for the assessment  *What is the recommendation to best answer the PIR  *Are their associated ISR task proving effective		*Determine what state PIR is in, is it answered, not answered.....	*Evaluate PIR			ISR Ops Strategist			*The system shall allow evaluation of PIR

## ISR D

Reference Code	#	CWR	IRR	Critical Cue and/or Factors	Critical Decisions	Actions	Common Errors	Tools used	Communicate with	Data Products used	Comments	Requirements
AFOTTP	20	Evaluate MOEs for ISR tasks	*Status: not started, in progress, or completed  *Effectiveness of the tasks: not effective, partially effective, or effective	*Status of for each MOE	*Determine if MOE has been met and successful	*Evaluate MOE			ISR Ops Strategist			*The system shall allow evaluation of MOEs
AFOTTP	21	Assessment of intel data	*Desired effects  *Undesired effects  *Missions		*Determine accuracy of all data compared to intel data	*Evaluate intel data			ISR Ops Strategist	ISR uses  *IMINT  *SIGINT  *MASINT  *HUMINT		*The system shall allow evaluation of intel data compared to other sources of data

## JAOP Development Consulting

Reference Code	#	CWR	IRR	Critical Cue and/or Factors	Critical Decisions	Actions	Common Errors	Communicate with	Data Products used	Comments	Requirements
AFOTTP	1	Recommend changes to JAOP	*COA  *Objectives  *Desired effects  *Status of adversary  *Status of friendly		*Determine how effectively/thoroughly JAOP supports campaign plan  *Determine how thoroughly and effectively it supports the overall theater campaign plan from the perspective of operational assessment	*Evaluate Air, space, and IO effectiveness and efficiency			*JAOP  *Intel data *DISUM / INSUM		*The system shall aid in determining how effectively/thoroughly JAOP supports campaign plan  *The system shall aid in determining how thoroughly and effectively it supports the overall theater campaign plan from the perspective of operational assessment
AFOTTP	2	Recommend to Strategy Plans Team for branch and/or sequel planning considerations									*The system shall aid in recommending to Strategy Plans Team for branch and/or sequel planning considerations
AFOTTP	3	Identify/establish linkages with sources of information and intel that will be	*Know who to contact for pieces of information		*Determine critical sources of information  *Determine when	*Establish contacts with resources					*The system shall provide access to various types of resources  *The system shall provide a way to request

## JAOP Development Consulting

Reference Code	#	CWR	IRR	Critical Cue and/or Factors	Critical Decisions	Actions	Common Errors	Communicate with	Data Products used	Comments	Requirements
		required to support JAOP development in the planning stage and a dynamic Operational Assessment process during execution based on information and intelligence from sources within and outside JAOC			information is needed  *Determine reliable sources of information						for information
Reg	4	Provide a coherent EBO representation	*Desired effects  *Linkage to tasks/objectives  *Rational behind the decisions made in the process		*Determine how to assess the desired effects against objectives  *Determine how to determine if objectives are being met					*Indicators are a good start for better defining the Commanders Critical information requirements (CCIR) and providing increased focus for ISR tasking	*The system shall aid in determining how to assess the desired effects against objectives  *The system shall aid in determining how to determine if objectives are being met

## JAOP Development Consulting

Reference Code	#	CWR	IRR	Critical Cue and/or Factors	Critical Decisions	Actions	Common Errors	Communicate with	Data Products used	Comments	Requirements
			*Indicators								

## JAOP Development Consulting

Reference Code	#	CWR	IRR	Critical Cue and/or Factors	Critical Decisions	Actions	Common Errors	Communicate with	Data Products used	Comments	Requirements
Reg	5	Continue linking COA through the MAAP	*EBO Lexicon		<p>*What do we want the enemy to do?</p> <p>*What part of the enemy must we effect to make them do it?</p> <p>*What reaction do we anticipate and why do we think this?</p> <p>*What objectives are we supporting and how does this accomplish them? *Why do we want to achieve them (effects and objectives)?</p> <p>*Where and when and to what degree do we need to attain the desired effects?</p>					<p>Either the system must provide those executing with all of the relevant information or it must provide them the means with which to request and receive the information in a timely manner.</p>	<p>*The system shall aid in determining what we want the enemy to do?</p> <p>*The system shall aid in determining what part of the enemy must we effect to make them do it?</p> <p>*The system shall aid in determining what reaction do we anticipate and why do we think</p> <p>*The system shall aid in determining what objectives are we supporting and how does this accomplish them?</p>

## JAOP Development Consulting

Reference Code	#	CWR	IRR	Critical Cue and/or Factors	Critical Decisions	Actions	Common Errors	Communicate with	Data Products used	Comments	Requirements
MEBOPC	6	Develop an ops assessment plan for JAOP planning and execution	*Blue COMM, logistics, space, operations, IO,  *ISR  *enemy intel  *Commander preferred option for achieving the end state  *Prior intel collection plans one they are available		*Determine assessment shortfalls	*Integrate multiple sources  *Integrate multiple collection strategies  *Develop procedures for gathering and exploiting  *Identify and establish links to info/intel required for JAOP development  *Identify and establish linkages to info or intel sources that can support CA and OA  *Develop and periodically review/refine collection requirements required		ISRD	*BDA  *CA  *MEA  *MA  *RR		*The system shall provide the capability to integrate multiple sources  *The system shall provide the capability to integrate multiple collection strategies  *The system shall provide the capability to develop procedures for gathering and exploiting  *The system shall provide the capability to identify and establish links to info/intel required for JAOP development  *The system shall provide the capability to identify and establish linkages to info or intel sources that can support CA and OA  *The system shall provide the capability to develop and periodically review/refine collection requirements required by the blue planners

## JAOP Development Consulting

Reference Code	#	CWR	IRR	Critical Cue and/or Factors	Critical Decisions	Actions	Common Errors	Communicate with	Data Products used	Comments	Requirements
						by the blue planners					
MEBOPC	7	Develop STTM			<p>*Determine/describe the desired change to those elements and/or relationships in terms of a numerical graphical trend</p> <p>*Determine/describe the threshold of change to system elements and/or relationships that indicates completion of the related action</p>	<p>*Identify SI for OO</p> <p>*Identify MOE for TO</p> <p>*Identify MOP for TT</p> <p>*Describe the elements and or relationships of the system that need to be observed in order to determine whether the assigned actions have been completed</p>		*Component planners			<p>*The system shall aid in determining/describing the desired change to those elements and/or relationships in terms of a numerical graphical trend</p> <p>*The system shall aid in determining/describing the threshold of change to system elements and/or relationships that indicates completion of the related action</p>

**Monitor/Evaluate/Report Air Ops Results Related to JFACC OO**

Monitor/Evaluate/Report Air Ops Results Related to JFACC OO												
Reference Code	#	CWR	IRR	Critical Cue and/or Factors	Critical Decisions	Actions	Common Errors	Tools used	Communicate with	Data Products used	Comments	Requirements

**Monitor/Evaluate/Report Air Ops Results Related to JFACC OO**

Reference Code	#	CWR	IRR	Critical Cue and/or Factors	Critical Decisions	Actions	Common Errors	Tools used	Communicate with	Data Products used	Comments	Requirements
	1	Assess direct and indirect effects of air, space and IO on the established plan	*Adversary behaviors  *Mission successes/failures  *Desired/undesired effects  *Objectives  *COAs	*Changes in environment / weather	*Determine if the plan was successful  *Determine if measures were effective	*Evaluate data						*The system shall allow and aid in the assessment of both direct and indirect effects of air, space and IO on the established plan
	2	Derive intended and unintended consequences of air ops wrt platforms, munitions, culture, population	*Adversary behaviors  *Mission successes/failures  *Desired/undesired effects  *Objectives  *COAs	*Changes in environment / weather  *Changes in Adversary behavior	*Determine consequences							*The system shall allow and aid in the derivation of the intended and unintended consequences of air ops wrt platforms, munitions, culture, population

## Monitor/Evaluate/Report Air Ops Results Related to JFACC OO

Reference Code	#	CWR	IRR	Critical Cue and/or Factors	Critical Decisions	Actions	Common Errors	Tools used	Communicate with	Data Products used	Comments	Requirements
	3	Determine when and what to report to JFACC	*Plan vs. Actual *Mission success vs failures *Objectives *Effects	*Behind plan *Ahead of schedule *Not going to achieve plan	*Determine the difference between the plan and actual events *Determine how mission failures will affect the overall plan *Determine how effective mission successes were *Determine if we are behind plan *Determine if we are ahead of schedule *Determine if current COA will effectively achieve plan	*Report to JFACC		Power Point	JFACC			*The system shall allow and aid in determining when and what to report to JFACC *The system shall aid in determining the difference between the plan and actual events *The system shall aid in determining how mission failures will affect the overall plan *The system shall aid in determining how effective mission successes were *The system shall aid in determining if we are behind plan *The system shall aid in determining if we are ahead of schedule *The system shall aid in determining if current COA will effectively achieve plan
	4	Report on air space and IO execution	*Plan vs. Actual *Mission success vs failures *Objectives	*Behind plan *Ahead of schedule *Not going to achieve plan	*Determine what to report on *Determine how much information to put in presentation			Power Point				*The system shall aid in determining what to report on *The system shall aid in determining how much information to put in presentation

**Monitor/Evaluate/Report Air Ops Results Related to JFACC OO**

Reference Code	#	CWR	IRR	Critical Cue and/or Factors	Critical Decisions	Actions	Common Errors	Tools used	Communicate with	Data Products used	Comments	Requirements
			*Effects									
	5	Recognize actionable changes in ongoing air ops	*Unanticipated enemy actions  *current Enemy COA	*Change in pathways  *Change in weather	*Determine when changes have been made in ongoing air ops							*The system shall allow and aid in recognizing actionable changes in ongoing air ops
	6	Monitor collection planning	*Know when, who and how data is going to be collected	*Data not available on deadline	*Determine if another source or type of data can be used	*Monitor  Request for more other information			ISR			*The system shall keep track of incoming data according to the when, who and how

## Monitor/Evaluate/Report Air Ops Results Related to JFACC OO

Reference Code	#	CWR	IRR	Critical Cue and/or Factors	Critical Decisions	Actions	Common Errors	Tools used	Communicate with	Data Products used	Comments	Requirements
	7	Synch collection planning and execution	*Adversary behaviors  *Mission successes/failures  *Desired/undesired effects  *Objectives  *COAs  *Mission successes/failures  *DMPI and Sortie status	*Actual vs. Planned	*Determine if actual events coincide with the plan  *Determine if you are achieving your plan  *Determine where the plan is going wrong  *Determine if plan needs to be modified	*Evaluate plan against actual events  *Evaluate data				Intel data		*The system shall aid in determining if actual events coincide with the plan  *The system shall aid in determining if you are achieving your plan  *The system shall aid in determining where the plan is going wrong  *The system shall aid in determining if the plan needs to be modified
	8	Evaluate MOEs	*Collection plan  *Timing of execution of mission  *Timing when data is to be collected against mission		*Compare objectives and tasks to MOEs to determine effectiveness							*The system shall provide the capability to compare objectives and tasks to MOEs to determine effectiveness

## Monitor/Evaluate/Report Air Ops Results Related to JFACC OO

Reference Code	#	CWR	IRR	Critical Cue and/or Factors	Critical Decisions	Actions	Common Errors	Tools used	Communicate with	Data Products used	Comments	Requirements
	9	Evaluate MOPs	*Collection plan  *Timing of execution of mission  *Timing when data is to be collected against mission		*Compare tasks to MOPs to determine effectiveness							*The system shall provide the capability to compare tasks to MOPs to determine effectiveness
	10	Evaluate Sis	*Collection plan  *Timing of execution of mission  *Timing when data is to be collected against mission		*Compare objectives to Sis to determine effectiveness							*The system shall provide the capability to compare objectives to Sis to determine effectiveness
	11	Evaluate effects	*Time effect is to be in place	*Anticipated  *Unanticipated	*Determine if we actually implemented effect  *Determine duration of effect							*The system shall aid in determine if we actually implemented the effect  *The system shall aid in determining the duration of effect

## Monitor/Evaluate/Report Air Ops Results Related to JFACC OO

Reference Code	#	CWR	IRR	Critical Cue and/or Factors	Critical Decisions	Actions	Common Errors	Tools used	Communicate with	Data Products used	Comments	Requirements
	1 2	Produce briefings	*Recent air ops *Friendly status brief *Intel assessment *Options and recommendations *JFACC discussion topics *What data to include in report	*Time	*Determine what to put in report  *Determine recommendations  *Determine confidence  *Determine status	*Performed twice daily (Morning and night)		Power point		*Recent air ops *Friendly status brief *Intel analysis assessment *Components assessment *JFACC discussion topics	*Provides a baseline for JFC briefing  *Provides accomplishment of objectives	*The system shall provide the ability to determine what to put in report  *The system shall aid in determine recommendations  *The system shall aid in determining confidence  *The system shall aid in determining status

## OAT Chief

Reference Code	#	CWR	"IRR"	Critical Cue and/or Factors	Critical Decisions	Actions	Common Errors	Tools used	Communicate with	Data Products used	Requirements
----------------	---	-----	-------	-----------------------------	--------------------	---------	---------------	------------	------------------	--------------------	--------------

## OAT Chief

OAT Chief											
Reference Code	#	CWR	"IRR"	Critical Cue and/or Factors	Critical Decisions	Actions	Common Errors	Tools used	Communicate with	Data Products used	Requirements
AFOTTP	1	Set up daily meeting to discuss progress on air and space objectives				*Attend meeting					*The system shall provide reminders of re-occurring meetings
AFOTTP	2	Run daily meeting to discuss progress on air and space objectives	*Mission for the previous day  *Changes in objectives	*Success of previous day(s) in regards to objectives  *Failures  *Effects							*The system shall provide a means to access briefings that were briefed during meeting
AFOTTP	3	In conjunction with the OAT Chief and the CA Team, make re-attack recommendations based on achievement of operational level objectives.	*Desired effect  *Undesired effects  *Unintended effects  *Adversary behaviors	*Adversary behaviors in reaction to mission  *Success/failures of missions	*Determine if a re-attack is needed	*Make recommendation		*Targeting Strategist  *CA Team	*MEA  *BDA  *MA		*The system shall provide decision aiding tools to determine re-attack needs
AFOTTP	4	Execution Floor OA Representative(s) Report execution status to the OAT Chief and make recommendations toward the current operational assessment.	*Recommendations on execution status	*Execution status vs planned status	*Evaluate recommendations				*Execution Floor OA Representative(s)		*The system shall provide access to Execution Floor OA Representative(s) reports  *The system shall provide decision aiding tools to compare reports (actual events) to planned events to help develop a new/modified OA plan

## OAT Chief

OAT Chief											
Reference Code	#	CWR	"IRR"	Critical Cue and/or Factors	Critical Decisions	Actions	Common Errors	Tools used	Communicate with	Data Products used	Requirements
AFOTTP	5	Battlefield Coordination Detachment (BCD) Intel Analyst make recommendations to the OAT Chief for updates to the JFACC operational assessment.	*BCD Intel recommendations		*Evaluate recommendations				*Battlefield Coordination Detachment (BCD) Intel Analyst		*The system shall provide access to Battlefield Coordination Detachment (BCD) Intel Analyses reports
AFOTTP	6	Component Representatives make recommendations to the OAT Chief for updates to the JFACC operational assessment.	*Recommendations made from component reps		*Evaluate recommendations				*Component Representatives		*The system shall provide access to Component Representatives reports
AFOTTP	7	Identify manning requirements. Work to source and build the team.	*Positions to be filled  *Availability of personnel  *Qualifications of personnel  *Mission to be accomplished		*Determine how to build team						*The system shall provide team information (availability, role)  *The system shall provide a way to assign tasks to team members
AFOTTP	8	Develop comprehensive assessment plan, including process assessment plan	*JFC/JFACC Objectives  *Desired effects  *Undesired effects	*Success of previous day(s)  *Failures  *Effects	*Determine what OA plan will be	*Augment staff to develop a process assessment plan	*Not have all data needed to develop comprehensive plan				*The system shall provide decision aiding tools in plan development

## OAT Chief

OAT Chief											
Reference Code	#	CWR	"IRR"	Critical Cue and/or Factors	Critical Decisions	Actions	Common Errors	Tools used	Communicate with	Data Products used	Requirements
AFOTTP	9	Define and document roles and responsibilities of each team member	*What roles are and their responsibilities			Meet with each team member prior to deployment					*The system shall provide the ability to define and document roles and responsibilities of each team member
AFOTTP	10	Identify specific people to fill positions				*Use AF studies and analysis agency to help identify analysts to meet requirements  *Identify process assessment team. Bring them early into the planning process					*The system shall provide the ability to identify specific people to fill positions
AFOTTP	11	Determine clearance/access requirement	*Team Chief, Deputy Team Chief and an analyst need COAL Warfighter access (CW)  *What other positions require what clearances								*The system shall provide clearance/access requirement(s)
AFOTTP	12	Establish procedures to ensure the OA team published a complete, accurate, properly formatted, and timely OA Report	*Know what an accurate report looks like	*Objectives  *Task accomplishment  *Plan	*Determine if report is accurate, complete, and properly formatted	*Report and assess AOD, ITO, Weaponered Sourced JPITL, MAAP and JAOP effectiveness in terms of objective and task accomplishment, adherence or divergence from the established plan, and optimum use of available resources (e.g. sorties, munitions, etc.).				*AOD  *ITO  *Weaponered Sourced JPITL  *MAAP  *JAOP	*The system shall supply a standard formatted report to use and to compare

## OAT Chief

OAT Chief											
Reference Code	#	CWR	"IRR"	Critical Cue and/or Factors	Critical Decisions	Actions	Common Errors	Tools used	Communicate with	Data Products used	Requirements
AFOTTP	13	Establish standard operating procedures specific to the theater of operations (link to SOP)	*SPINS  *Other rules of the area  *Objectives								*The system shall allow the establishment of standard operating procedures that are specific to the theater of operations
AFOTTP	14	Establish OAT battle rhythm and work schedule									*The system shall allow the establishment of an OAT battle rhythm and work schedule
AFOTTP	15	Participate in daily strategy meetings	*JFC/JFACC Objectives  *Desired effects  *Undesired effects	*Determining what is measurable and not measurable for the OA plan	*Determining if COA can be measured and are logical for the OA team to assess and measure	*Participate in meetings			*Strat team		
AFOTTP	16	Brief Operational Assessment during the daily JFACC decision briefing	*Standard format of briefing	*Color coding  *What is intended to be emphasized	*Determine color coding  *Determine critical pieces of information	*Produce briefing	*Take too long to develop briefing  *Not have up to date information				*The system shall easily transfer data into a briefing format

**This page blank intentionally.**

# **APPENDIX B**

## **OEAVT SYSTEM MODEL (CORE EFFBDs)**

# CORE Database for Project: OEA VT

Select one of the following Class or Folder links to get a list of local elements

- Activities
- Annotation
- Cognitive Work Requirement
- CompletionCriterion
- Component
- Constaints & Dependencies
- CWR
- Data
- Data Sources
- Document
- ExternalGraphic
- ExternalText
- Function
- Glossary
- Goal Process Node
- Implication
- Information Relationship Requirements
- Interface
- IRR
- Issue
- Item
- OriginatingRequirement
- Participants
- Process Step
- Products
- System
- Text
- Workflow

## Operational Assessment Enhanced FFBD

Element View:

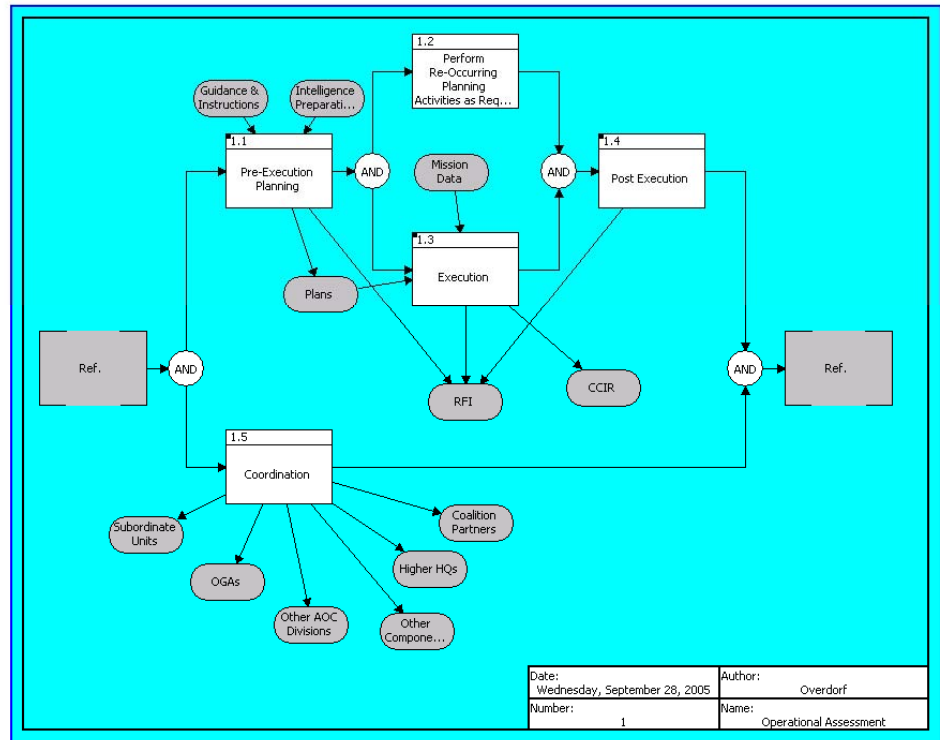

CORE Database Homepage - Microsoft Internet Explorer

File Edit View Favorites Tools Help

## CORE Database for Project: OEAVT

Select one of the following Class or Folder links to get a list of local elements

- Activities
- Annotation
- Cognitive Work Requirement
- CompletionCriterion
- Component
- Constraints & Dependencies
- CWR
- Data
- Data Sources
- Document
- ExternalGraphic
- ExternalText
- Function
- Glossary
- Goal\_Process\_Node
- Implication
- Information Relationship
- Requirements
- Interface
- JRR
- Issue
- Item
- OriginatingRequirement
- Participants
- Process Step
- Products
- System
- Text
- Workflow

### Pre-Execution Planning Enhanced FFBD

Element View: Enhanced FFBD

```

    graph LR
      Ref[Ref.] --> 1.1.1[Evaluate effectiveness of JFACC objectives in supporting JFC Guidance]
      1.1.1 -- AND --> 1.1.2[COA Development Consulting]
      1.1.2 --> 1.1.3[COA Analysis/Wargaming Consulting]
      1.1.3 --> 1.1.4[COA Comparison/Selection]
      1.1.4 --> SelectedCOA[Selected COA]
      1.1.2 --> 1.1.5[Operational Research]
      1.1.5 --> 1.1.6[Develop overall OA Plan]
      1.1.6 --> 1.1.7[JACP Development Consulting]
      1.1.7 --> 1.1.8[AOD development Consulting]
      1.1.8 -- AND --> 1.2[Perform Re-Occurring Planning Activities as Req...]
      1.2 --> 1.3[Execution]
  
```

The diagram is a Flowchart (FFBD) for Pre-Execution Planning. It starts with a 'Ref.' box pointing to task 1.1.1 'Evaluate effectiveness of JFACC objectives in supporting JFC Guidance'. This leads to an 'AND' connector, which then branches into two paths. The top path consists of tasks 1.1.2 'COA Development Consulting', 1.1.3 'COA Analysis/Wargaming Consulting', and 1.1.4 'COA Comparison/Selection', leading to 'Selected COA'. The bottom path consists of tasks 1.1.5 'Operational Research' and 1.1.6 'Develop overall OA Plan'. Both paths converge at an 'AND' connector, which leads to task 1.1.7 'JACP Development Consulting'. This leads to task 1.1.8 'AOD development Consulting', which then leads to another 'AND' connector. This connector leads to task 1.2 'Perform Re-Occurring Planning Activities as Req...', which finally leads to task 1.3 'Execution'. Various other elements like 'Military End State', 'Measures of Effect', 'COA Alternatives', 'COA Branches...', 'Operational & Tactical...', 'Measures of Perform...', 'Tactical Objectives', 'JACP Compose...', 'Operational Objectives', 'COA Effective...', 'Validated COAs', 'Rules of Engagem...', 'Special Instruction', 'Intelligence Preparati...', and 'Information Requiem...' are shown as inputs or outputs to the main task flow.

Date: Thursday, June 16, 2005	Author: Overdorf
Number: 1.1	Name: Pre-Execution Planning

CORE Database Homepage - Microsoft Internet Explorer

File Edit View Favorites Tools Help

# CORE Database for Project: OEAVT

Select one of the following Class or Folder links to get a list of local elements

- [Activities](#)
- [Annotation](#)
- [Cognitvie Work Requirement](#)
- [CompletionCriterion](#)
- [Component](#)
- [Constaints & Dependencies](#)
- [CWR](#)
- [Data](#)
- [Data Sources](#)
- [Document](#)
- [ExternalGraphic](#)
- [ExternalText](#)
- [Function](#)
- [Glossary](#)
- [Goal Process Node](#)
- [Implication](#)
- [Information Relationship Requirements](#)
- [Interface](#)
- [IRR](#)
- [Issue](#)
- [Item](#)
- [OriginatingRequirement](#)
- [Participants](#)
- [Process Step](#)
- [Products](#)
- [System](#)
- [Text](#)
- [Workflow](#)

## Evaluate effectiveness of JFACC objectives in supporting JFC objectives Enhanced FFBD

Element View: Enhanced FFBD

```

graph LR
    Ref[Ref.] --> 1.1.1.1[1.1.1.1 Integrate JFC & JFACC operational assessments]
    JFC_Guidance((JFC_Guidance)) --> 1.1.1.1
    1.1.1.1 --> AND((AND))
    AND --> 1.1.2[1.1.2 COA Development Consulting]
    AND --> 1.1.5[1.1.5 Operational Research]
    AND --> 1.1.6[1.1.6 Develop overall OA Plan]
  
```

Date: Thursday, June 16, 20...	Author: Overdorf
Number: 1.1.1	Name: Evaluate effectiveness of JFACC objectives in supporting JFC o...

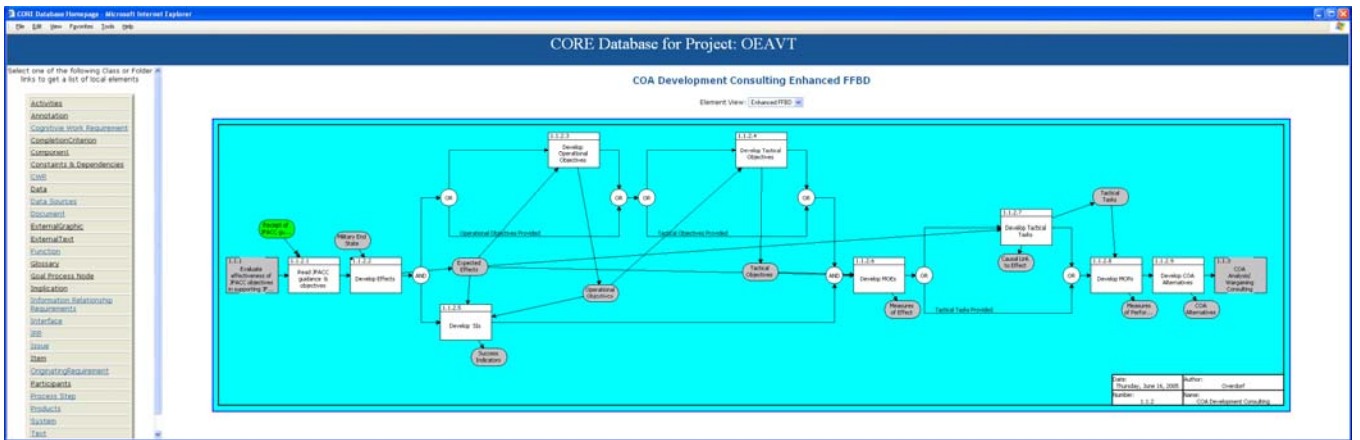

CORE Database Homepage - Microsoft Internet Explorer

File Edit View Favorites Tools Help

## CORE Database for Project: OEAVT

Select one of the following Class or Folder links to get a list of local elements

- Activities
- Annotation
- Cognitive Work Requirement
- CompletionCriterion
- Component
- Constaints & Dependencies
- CWR
- Data
- Data Sources
- Document
- ExternalGraphic
- ExternalText
- Function
- Glossary
- Goal Process Node
- Implication
- Information Relationship Requirements
- Interface
- IRR
- Issue
- Item
- OriginatingRequirement
- Participants
- Process Step
- Products
- System
- Text
- Workflow

### Develop Effects Enhanced FFBD

Element View: Enhanced FFBD

```

    graph LR
      A[1.1.2.1 Read JFACC guidance & objectives] -- AND --> B[1.1.2.2.1 Identify Intended Effects]
      A -- AND --> C[1.1.2.2.2 Identify Indirect Effects]
      A -- AND --> D[1.1.2.2.3 Identify Cumulative Effects]
      A -- AND --> E[1.1.2.2.4 Identify Undesired Effects]
      A -- AND --> F[1.1.2.2.5 Identify Cascading Effect?]
      B -- Intended Effects --> G(( ))
      C -- Indirect Effect --> G
      D -- Cumulative Effects --> G
      E -- Undesired Effects --> G
      F -- Cascading Effects --> G
      G -- AND --> H[1.1.2.3 Develop Operational Objectives]
      G -- AND --> I(( ))
      I -- OR --> J[1.1.2.4 Develop Tactical Objectives]
      I -- OR --> K[1.1.2.6 Develop MOEs]
      I -- AND --> L[1.1.2.5 Develop SIs]
  
```

The diagram illustrates the 'Develop Effects Enhanced FFBD' process. It begins with activity 1.1.2.1, 'Read JFACC guidance & objectives'. This activity leads to five parallel identification tasks: 1.1.2.2.1 'Identify Intended Effects', 1.1.2.2.2 'Identify Indirect Effects', 1.1.2.2.3 'Identify Cumulative Effects', 1.1.2.2.4 'Identify Undesired Effects', and 1.1.2.2.5 'Identify Cascading Effect?'. Each of these tasks produces a corresponding effect (Intended Effects, Indirect Effect, Cumulative Effects, Undesired Effects, and Cascading Effects). These effects are then combined via an AND gate to lead to activity 1.1.2.3 'Develop Operational Objectives'. Additionally, the combined effects lead to an OR gate, which branches into two paths: one leading to activity 1.1.2.4 'Develop Tactical Objectives' and another leading to activity 1.1.2.6 'Develop MOEs'. Finally, the combined effects also lead to activity 1.1.2.5 'Develop SIs' through an AND gate.

CORE Database Homepage - Microsoft Internet Explorer

File Edit View Favorites Tools Help

## CORE Database for Project: OEAVT

Select one of the following Class or Folder links to get a list of local elements

- [Activities](#)
- [Annotation](#)
- [Cognitive Work Requirement](#)
- [CompletionCriterion](#)
- [Component](#)
- [Constaints & Dependencies](#)
- [CWR](#)
- [Data](#)
- [Data Sources](#)
- [Document](#)
- [ExternalGraphic](#)
- [ExternalText](#)
- [Function](#)
- [Glossary](#)
- [Goal Process Node](#)
- [Implication](#)
- [Information Relationship Requirements](#)
- [Interface](#)
- [IRR](#)
- [Issue](#)
- [Item](#)
- [OriginatingRequirement](#)
- [Participants](#)
- [Process Step](#)
- [Products](#)
- [System](#)
- [Text](#)
- [Workflow](#)

### COA Analysis/Wargaming Consulting Enhanced FFBD

Element View: Enhanced FFBD

```

graph LR
    A1[COA Alternatives] --> B[1.1.3.1 Validation of COA Effectiveness]
    A2[COA Effective...] --> B
    B --> C[1.1.3.2 Provide recommendations for branch & sequel planning]
    C --> D[1.1.4 COA Comparison/ Selection]
    C --> E[Validated COAs]
    C --> F[COA Branches...]
    G[1.1.2 COA Development Consulting] --> B
  
```

CORE Database Homepage - Microsoft Internet Explorer

File Edit View Favorites Tools Help

## CORE Database for Project: OEAVT

Select one of the following Class or Folder links to get a list of local elements

- Activities
- Annotation
- [Cognitive Work Requirement](#)
- CompletionCriterion
- Component
- Constaints & Dependencies
- [CWR](#)
- Data
- [Data Sources](#)
- [Document](#)
- [ExternalGraphic](#)
- [ExternalText](#)
- [Function](#)
- Glossary
- Goal Process Node
- Implication
- [Information Relationship Requirements](#)
- [Interface](#)
- IRR
- [Issue](#)
- Item
- [OriginatingRequirement](#)
- Participants
- [Process Step](#)
- [Products](#)
- [System](#)
- [Text](#)
- [Workflow](#)

### COA Comparison/Selection Enhanced FFBD

Element View: Enhanced FFBD

```

graph LR
    A[1.1.3 COA Analysis/Wargaming Consulting] --> B[1.1.4.1 Develop COA Selection Matrix]
    B --> C[1.1.4.2 Populate COA Selection Matrix & Select COA]
    C --> D[1.1.7 JAOP Development Consulting]
    E((Validated COAs)) --> C
    B --> F((Selection Matrix))
    C --> G((Selected COA))
    
```

CORE Database Homepage - Microsoft Internet Explorer

File Edit View Favorites Tools Help

## CORE Database for Project: OEAVT

Select one of the following Class or Folder links to get a list of local elements:

- Activities
- Annotation
- Cognitive Work Requirement
- CompletionCriterion
- Component
- Constraints & Dependencies
- CWR
- Data
- Data Sources
- Document
- ExternalGraphic
- ExternalText
- Function
- Glossary
- Goal Process Node
- Implication
- Information Relationship
- Requirements
- Interface
- IRB
- Issue
- Item
- OriginatingRequirement
- Participants
- Process Step
- Products
- System
- Text
- Workflow

### JAOP Development Consulting Enhanced FFBD

Element View: Enhanced FFBD

Date:	Thursday, June 16, 2005	Author:	Overdorf
Number:	1.1.7	Name:	JAOP Development Consulting

CORE Database Homepage - Microsoft Internet Explorer

File Edit View Favorites Tools Help

## CORE Database for Project: OEAVT

Select one of the following Class or Folder links to get a list of local elements

- Activities
- Annotation
- Cognitive Work Requirement
- CompletionCriterion
- Component
- Constraints & Dependencies
- CWR
- Data
- Data Sources
- Document
- ExternalGraphic
- ExternalText
- Function
- Glossary
- Goal Process Node
- Implication
- Information Relationship Requirements
- Interface
- JRR
- Issue
- Item
- OriginatingRequirement
- Participants
- Process Step
- Products
- System
- Text
- Workflow

### Meeting; Planning for Joint Air Ops Enhanced FFBD

Element View: Enhanced FFBD

```

graph LR
    1.1.4[1.1.4 COA Comparison/ Selection] --> AND1((AND))
    1.1.5[1.1.5 Operational Research] --> AND1
    1.1.6[1.1.6 Develop overall OA Plan] --> AND1
    AND1 --> 1.1.7.1.1[1.1.7.1.1 Evaluates and/or Develops Guidance]
    1.1.7.1.1 --> AND2((AND))
    AND2 --> 1.1.7.2[1.1.7.2 Parallel JAOP development activities]
    AND2 --> 1.1.7.3[1.1.7.3 Define STIM]
  
```

CORE Database Homepage - Microsoft Internet Explorer

File Edit View Favorites Tools Help

## CORE Database for Project: OEAVT

Select one of the following Class or Folder links to get a list of local elements

- Activities
- Annotation
- Cognitive Work Requirement
- CompletionCriterion
- Component
- Constaints & Dependencies
- CWR
- Data
- Data Sources
- Document
- ExternalGraphic
- ExternalText
- Function
- Glossary
- Goal Process Node
- Implication
- Information Relationship Requirements
- Interface
- JRR
- Issue
- Item
- OriginatingRequirement
- Participants
- Process Step
- Products
- System
- Text
- Workflow

### Execution Enhanced FFBD

Element View: Enhanced FFBD

```

graph LR
    P11[1.1 Pre-Execution Planning] --> P131[1.3.1 RFI from ISRD]
    P131 --> AND1((AND))
    AND1 --> RFI((RFI))
    AND1 --> P134[1.3.4 Determine effectiveness of air ops in achieving assig...]
    P134 --> RFI
    RFI --> P132[1.3.2 Accrue Evidence and Data]
    RFI --> P133[1.3.3 Analyze Operational Results]
    P132 --> LP1((LP))
    P133 --> LP2((LP))
    LP1 --> P133
    LP2 --> AND2((AND))
    AND2 --> P135[1.3.5 Summarize Assessment Information for JFACC]
    AND2 --> Assessed((Assessed Effective...))
    Assessed --> P135
    P135 --> P14[1.4 Post Execution]
    
    MD((Mission Data)) --> P132
    TA((Tactical Assessme...)) --> P132
    P((Plans)) --> P132
    TT((Tactical Task)) --> P132
    E((Evidence)) --> P132
    IS((Intelligence Summaries)) --> P132
    ATO((ATO)) --> P132
    
    RE((Recommend ed Chang...)) --> P133
    CCIR((CCIR)) --> Assessed
  
```

Date: Thursday, June 16, 2005	Author: Overdorf
Number: 1.3	Name: Execution

# CORE Database for Project: OEAVT

Select one of the following Class or Folder links to get a list of local elements

- Activities
- Annotation
- Cognitive Work Requirement
- CompletionCriterion
- Component
- Constants & Dependencies
- CWR
- Data
- Data Sources
- Document
- ExternalGraphic
- ExternalText
- Function
- Glossary
- Goal Process Node
- Implication
- Information Relationship Requirements
- Interface
- IRR
- Issue
- Item
- OriginatingRequirement
- Participants
- Process Step
- Products
- System
- Text
- Workflow

## Accrue Evidence and Data Enhanced FFBD

Element View: Enhanced FFBD

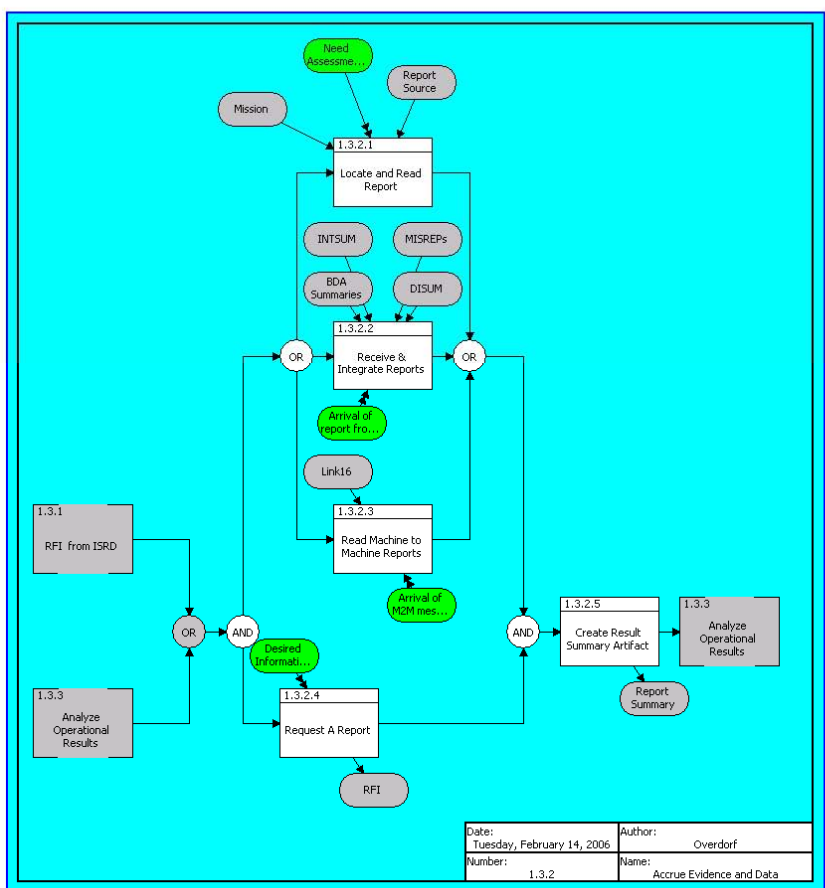

Date: Tuesday, February 14, 2006	Author: Overdorf
Number: 1.3.2	Name: Accrue Evidence and Data

CORE Database Homepage - Microsoft Internet Explorer

File Edit View Favorites Tools Help

## CORE Database for Project: OEAVT

Select one of the following Class or Folder links to get a list of local elements

- Activities
- Annotation
- Cognitive Work Requirement
- Completion Criterion
- Component
- Constraints & Dependencies
- CWN
- Data
- Data Sources
- Document
- External Graphic
- External Text
- Function
- Glossary
- Goal Process Node
- Implication
- Information Relationship
- Requirements
- Interface
- ISS
- Issue
- Item
- Originating Requirement
- Participants
- Process Step
- Products
- System
- Text
- Workflow

### Analyze Operational Results Enhanced FFBD

Element View: Enhanced FFBD

Date: Tuesday, February 14, 2006	Author: Overdorf
Number: 1.3.3	Name: Analyze Operational Results

# CORE Database for Project: OEA VT

Select one of the following Class or Folder links to get a list of local elements

- [Activities](#)
- [Annotation](#)
- [Cognitive Work Requirement](#)
- [CompletionCriterion](#)
- [Component](#)
- [Constraints & Dependencies](#)
- [CWR](#)
- [Data](#)
- [Data Sources](#)
- [Document](#)
- [ExternalGraphic](#)
- [ExternalText](#)
- [Function](#)
- [Glossary](#)
- [Goal Process Node](#)
- [Implication](#)
- [Information Relationship Requirements](#)
- [Interface](#)
- [IRR](#)
- [Issue](#)
- [Item](#)
- [OriginatingRequirement](#)
- [Participants](#)
- [Process Step](#)
- [Products](#)
- [System](#)
- [Text](#)
- [Workflow](#)

## Analyze Tactical Assessment Summaries Enhanced FFBD

Element View: Enhanced FFBD

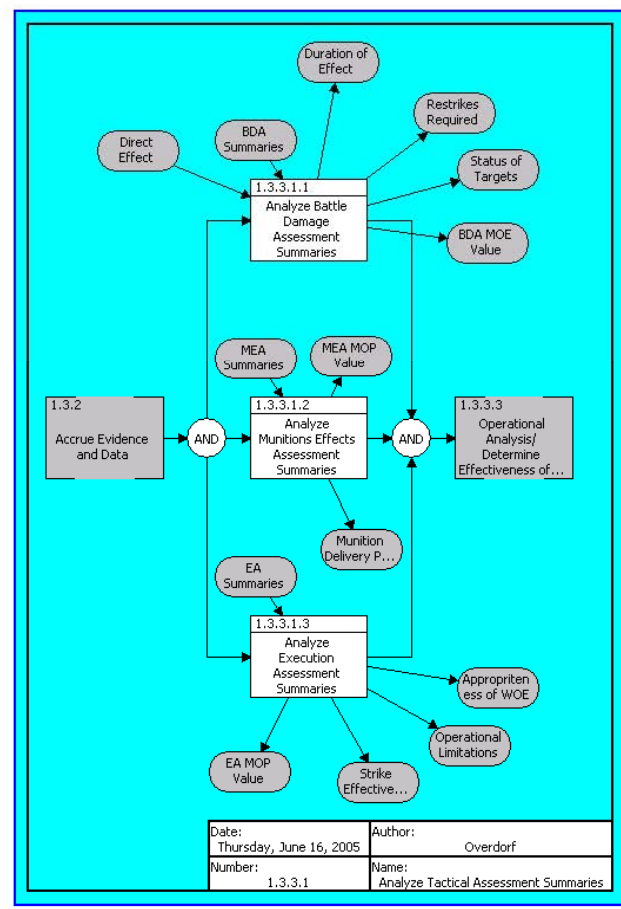

# CORE Database for Project: OEAVT

Select one of the following Class or Folder links to get a list of local elements

- Activities
- Annotation
- Cognitive Work Requirement
- CompletionCriterion
- Component
- Constaints & Dependencies
- CWR
- Data
- Data Sources
- Document
- ExternalGraphic
- ExternalText
- Function
- Glossary
- Goal Process Node
- Implication
- Information Relationship Requirements
- Interface
- IRP
- Issue
- Item
- OriginatingRequirement
- Participants
- Process Step
- Products
- System
- Text
- Workflow

## Activity Analysis Enhanced FFBD

Element View: Enhanced FFBD

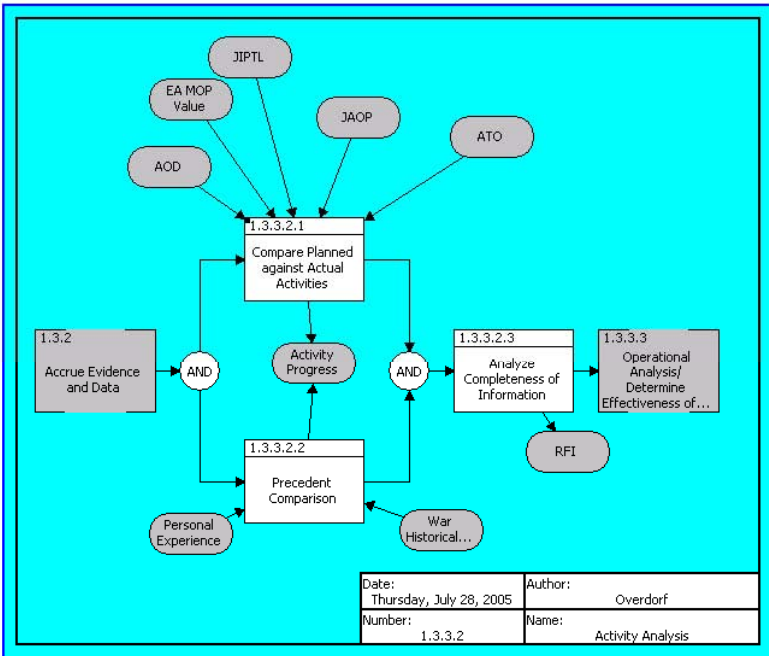

# CORE Database for Project: OEAVT

Select one of the following Class or Folder links to get a list of local elements

- Activities
- Annotation
- Cognitive Work Requirement
- CompletionCriterion
- Component
- Constaints & Dependencies
- CWR
- Data
- Data Sources
- Document
- ExternalGraphic
- ExternalText
- Function
- Glossary
- Goal Process Node
- Implication
- Information Relationship Requirements
- Interface
- IRR
- Issue
- Item
- OriginatingRequirement
- Participants
- Process Step
- Products
- System
- Text
- Workflow

## Compare Planned against Actual Activities Enhanced FFBD

Element View: **Enhanced FFBD**

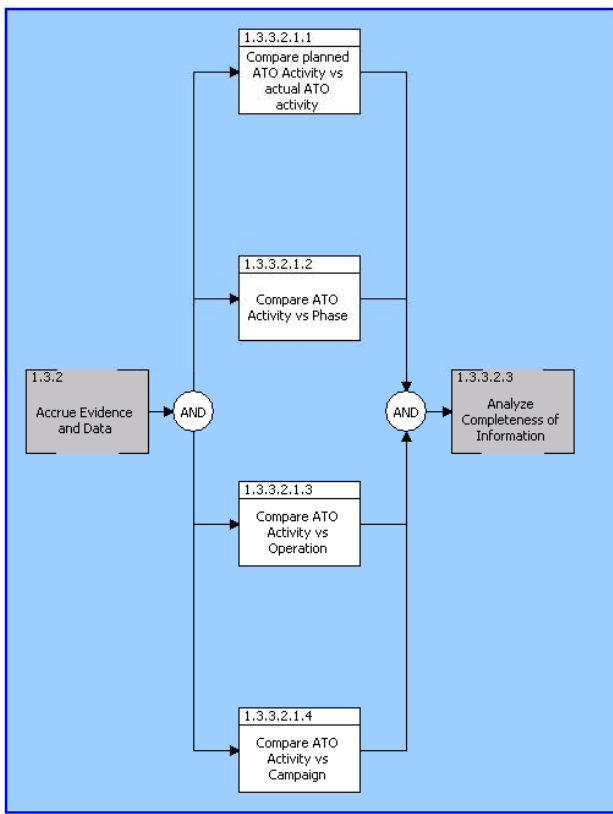

# CORE Database for Project: OEA VT

Select one of the following Class or Folder links to get a list of local elements

- [Activities](#)
- [Annotation](#)
- [Cognitive Work Requirement](#)
- [CompletionCriterion](#)
- [Component](#)
- [Constaints & Dependencies](#)
- [CWR](#)
- [Data](#)
- [Data Sources](#)
- [Document](#)
- [ExternalGraphic](#)
- [ExternalText](#)
- [Function](#)
- [Glossary](#)
- [Goal Process Node](#)
- [Implication](#)
- [Information Relationship Requirements](#)
- [Interface](#)
- [IRB](#)
- [Issue](#)
- [Item](#)
- [OriginatingRequirement](#)
- [Participants](#)
- [Process Step](#)
- [Products](#)
- [System](#)
- [Text](#)
- [Workflow](#)

## Operational Analysis/Determine Effectiveness of Air Campaign Enhanced FFBD

Element View: Enhanced FFBD

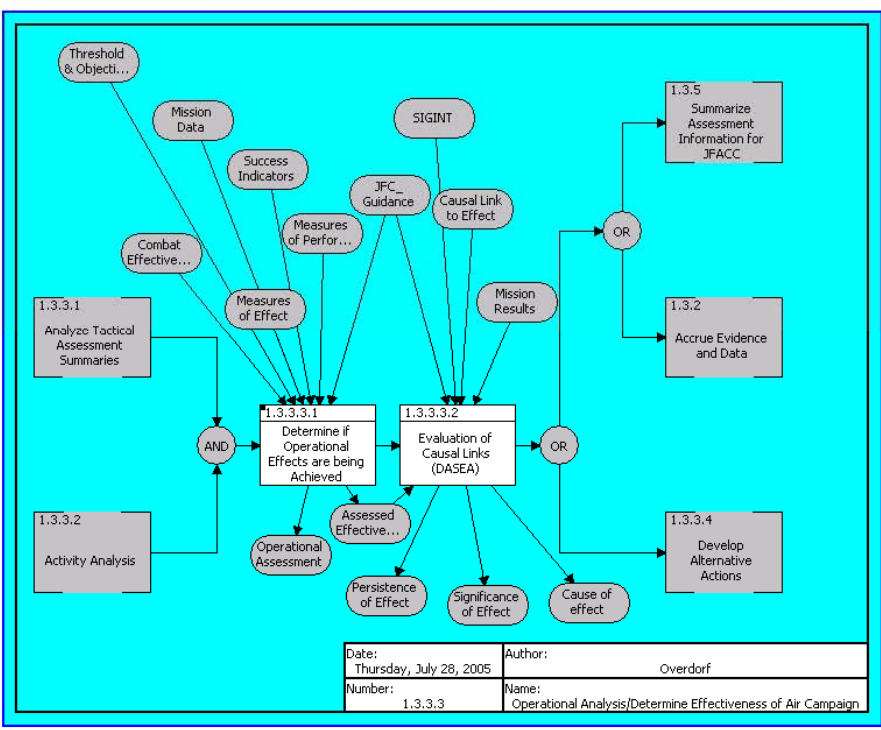

Date: Thursday, July 28, 2005	Author: Overdorf
Number: 1.3.3.3	Name: Operational Analysis/Determine Effectiveness of Air Campaign

# CORE Database for Project: OEAVT

Select one of the following Class or Folder links to get a list of local elements

- Activities
- Annotation
- Cognitive Work Requirement
- CompletionCriterion
- Component
- Constraints & Dependencies
- CWR
- Data
- Data Sources
- Document
- ExternalGraphic
- ExternalText
- Function
- Glossary
- Goal Process Node
- Implication
- Information Relationship Requirements
- Interface
- JRR
- Issue
- Item
- OriginatingRequirement
- Participants
- Process Step
- Products
- System
- Text
- Workflow

## Determine if Operational Effects are being Achieved Enhanced FFBD

Element View:

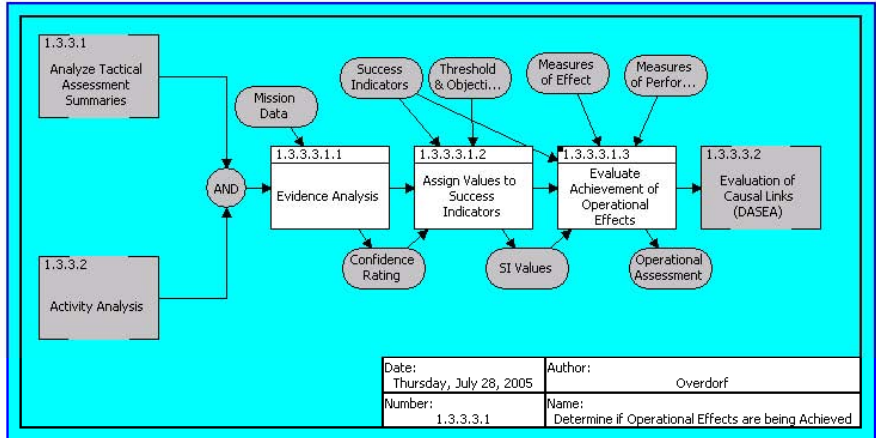

CORE Database Homepage - Microsoft Internet Explorer

File Edit View Favorites Tools Help

## CORE Database for Project: OEA VT

Select one of the following Class or Folder links to get a list of local elements

- Activities
- Annotation
- Cognitive Work Requirement
- CompletionCriterion
- Component
- Constaints & Dependencies
- CWR
- Data
- Data Sources
- Document
- ExternalGraphic
- ExternalText
- Function
- Glossary
- Goal Process Node
- Implication
- Information Relationship
- Requirements
- Interface
- IPR
- Issue
- Item
- OriginatingRequirement
- Participants
- Process Step
- Products
- System
- Text
- Workflow

### Evaluate Achievement of Operational Effects Enhanced FFBD

Element View: Enhanced FFBD

Date: Thursday, July 28, 2005	Author: Overdorf
Number: 1.3.3.3.1.3	Name: Evaluate Achievement of Operational Effects

# CORE Database for Project: OEA VT

Select one of the following Class or Folder links to get a list of local elements

- Activities
- Annotation
- Cognitive Work Requirement
- CompletionCriterion
- Component
- Constaints & Dependencies
- CWR
- Data
- Data Sources
- Document
- ExternalGraphic
- ExternalText
- Function
- Glossary
- Goal Process Node
- Implication
- Information Relationship
- Requirements
- Interface
- IPB
- Issue
- Item
- OriginatingRequirement
- Participants
- Process Step
- Products
- System
- Text
- Workflow

## Analyze and Validate SIs Enhanced FFBD

Element View: Enhanced FFBD

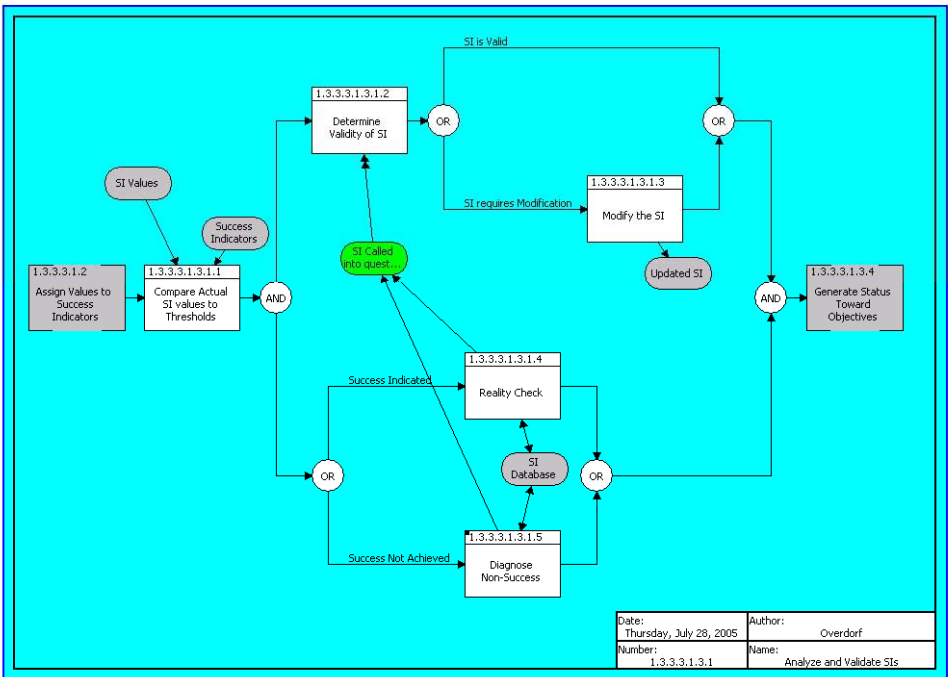

Date: Thursday, July 28, 2005	Author: Overdorf
Number: 1.3.3.3.1.3.1	Name: Analyze and Validate SIs

CORE Database Homepage - Microsoft Internet Explorer

File Edit View Favorites Tools Help

## CORE Database for Project: OEAVT

Select one of the following Class or Folder links to get a list of local elements

- Activities
- Annotation
- Cognitive Work Requirement
- CompletionCriterion
- Component
- Constraints & Dependencies
- CWR
- Data
- Data Sources
- Document
- ExternalGraphic
- ExternalText
- Function
- Glossary
- Goal Process Node
- Implication
- Information Relationship
- Requirements
- Interface
- IRR
- Issue
- Item
- OriginatingRequirement
- Participants
- Process Step
- Products
- System
- Text
- Workflow

### Diagnose Non-Success Enhanced FFBD

Element View: Enhanced FFBD

Date:	Thursday, July 28, 2005	Author:	Overdorf
Number:	1.3.3.3.1.3.1.5	Name:	Diagnose Non-Success

# CORE Database for Project: OEAVT

Select one of the following Class or Folder links to get a list of local elements

- Activities
- Annotation
- Cognitive Work Requirement
- CompletionCriterion
- Component
- Constaints & Dependencies
- CWR
- Data
- Data Sources
- Document
- ExternalGraphic
- ExternalText
- Function
- Glossary
- Goal Process Node
- Implication
- Information Relationship Requirements
- Interface
- JRR
- Issue
- Item
- OriginatingRequirement
- Participants
- Process Step
- Products
- System
- Text
- Workflow

## Compare Effects TimeLine Actual versus plan Enhanced FFBD

Element View: Enhanced FFBD

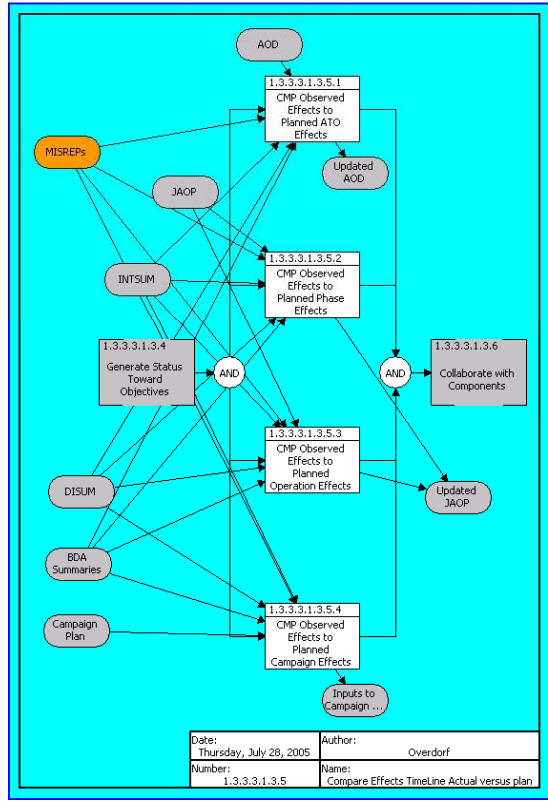

# CORE Database for Project: OEAVT

Select one of the following Class or Folder links to get a list of local elements

- [Activities](#)
- [Annotation](#)
- [Cognitive Work Requirement](#)
- [CompletionCriterion](#)
- [Component](#)
- [Constaints & Dependencies](#)
- [CWR](#)
- [Data](#)
- [Data Sources](#)
- [Document](#)
- [ExternalGraphic](#)
- [ExternalText](#)
- [Function](#)
- [Glossary](#)
- [Goal Process Node](#)
- [Implication](#)
- [Information Relationship Requirements](#)
- [Interface](#)
- [IRR](#)
- [Issue](#)
- [Item](#)
- [OriginatingRequirement](#)
- [Participants](#)
- [Process Step](#)
- [Products](#)
- [System](#)
- [Text](#)
- [Workflow](#)

## Summarize Assessment Information for JFACC Enhanced FFBD

Element View: Enhanced FFBD

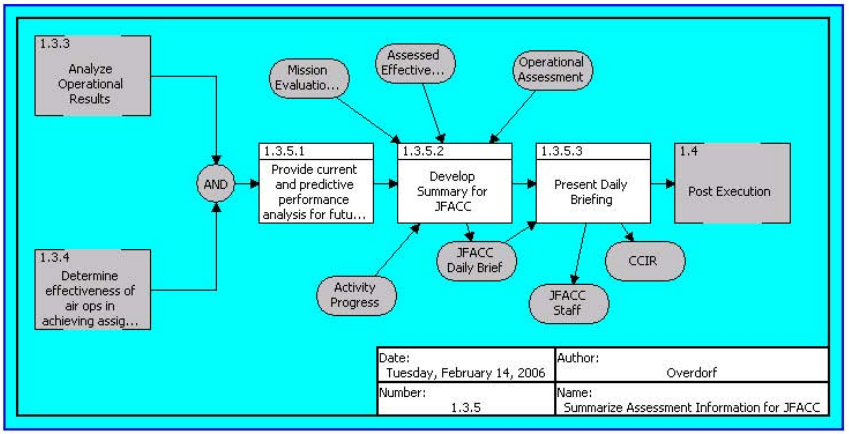

Date:	Tuesday, February 14, 2006	Author:	Overdorf
Number:	1.3.5	Name:	Summarize Assessment Information for JFACC

# CORE Database for Project: OEAVT

Select one of the following Class or Folder links to get a list of local elements

- Activities
- Annotation
- Cognitive Work Requirement
- CompletionCriterion
- Component
- Constaints & Dependencies
- CWR
- Data
- Data Sources
- Document
- ExternalGraphic
- ExternalText
- Function
- Glossary
- Goal Process Node
- Implication
- Information Relationship Requirements
- Interface
- JRR
- Issue
- Item
- OriginatingRequirement
- Participants
- Process Step
- Products
- System
- Text
- Workflow

## Post Execution Enhanced FFBD

Element View: Enhanced FFBD

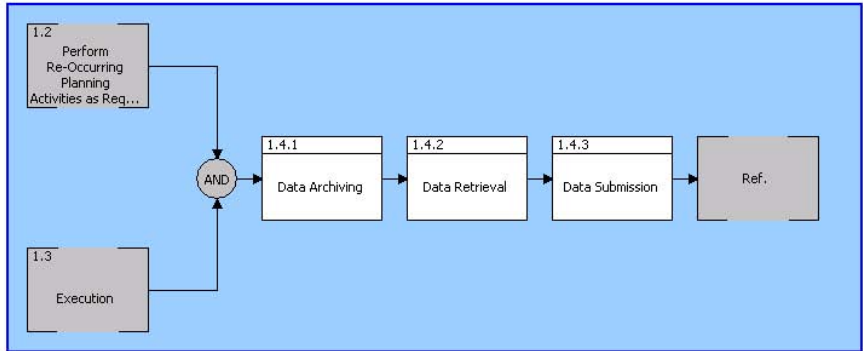

# **APPENDIX C**

## **OEAVT SYSTEM REQUIREMENTS**

Number & Name	Description	Status
1.1 Meeting Reminders	The system shall provide reminders of re-occurring meetings	15 Out of Scope Spreadsheet Requirements
1.2 Briefing Access	The system shall provide a means to access briefings that were briefed during meeting	Accepted
1.3 Re-attack Decision Aiding Tools	The system shall provide decision aiding tools to determine re-attack needs	15 Out of Scope Spreadsheet Requirements
1.4.1 Access to Execution Floor OA Reports	The system shall provide access to Execution Floor OA Representative(s) reports	16 Potential Requirements
1.4.2 Execution Floor OA Reports Aiding Tools	The system shall provide decision aiding tools to compare reports (actual events) to planned events to help develop a new/modified OA plan	Accepted
1.5 BCD Intel Analysis access	The system shall provide access to Battlefield Coordination Detachment (BCD) Intel Analyses reports	Accepted
1.6 Component Representative Report access	The system shall provide access to Component Representatives reports	15 Out of Scope Spreadsheet Requirements
1.7.1 Team Information	The system shall provide team information (availability, role)	15 Out of Scope Spreadsheet Requirements
1.7.2 Team Task Assignment	The system shall provide a way to assign tasks to team members	15 Out of Scope Spreadsheet Requirements
1.8 Decision Aiding Tools for Planning	The system shall provide decision aiding tools in plan development	15 Out of Scope Spreadsheet Requirements
1.9 Team Role Documentation	The system shall provide the ability to define and document roles and responsibilities of each team member	15 Out of Scope Spreadsheet Requirements
1.10 Filling Positions	The system shall provide the ability to identify specific people to fill positions	15 Out of Scope Spreadsheet Requirements
1.11 Clearance Access	The system shall provide clearance/access requirement(s)	15 Out of Scope Spreadsheet Requirements
1.12 Standard Report	The system shall supply a standard formatted report to use and to compare	Accepted
1.13 SOP procedures	The system shall allow the establishment of standard operating procedures that are specific to the theater of operations	15 Out of Scope Spreadsheet Requirements

<b>Number &amp; Name</b>	<b>Description</b>	<b>Status</b>
1.14 OAT Battle Rhythm	The system shall allow the establishment of an OAT battle rhythm and work schedule	15 Out of Scope Spreadsheet Requirements
1.15 Data to Briefing	The system shall easily transfer data into a briefing format	Accepted
2.1.1 IPB Assessment access	The system shall provide access to IPB assessment	Accepted
2.1.2 Adversary COA access	The system shall provide adversary COAs	16 Potential Requirements
2.1.3 COG access	The system shall provide access to COG information	16 Potential Requirements
2.1.4 Targeting Info access	The system shall provide targeting information	21 Additional Out-of-Scope Requirements
2.1.5 ISR OPs access	The system shall provide access to ISR operations	15 Out of Scope Spreadsheet Requirements
2.1.6 Adversary Activity info	The system shall provide information concerning adversary activity	Accepted
2.1.7 Adversary Status info	The system shall provide information on adversary status in battlespace	Accepted
2.1.8 ACF Info Access	The system shall access to ACF information	Accepted
2.1.9 Adversary Intention Info Access	The system shall provide adversary intentions	16 Potential Requirements
2.1.10 Adversary Strategy Info Access	The system shall provide adversary strategies	16 Potential Requirements
2.1.11 Adversary End State Info Access	The system shall provide adversary end state	16 Potential Requirements
2.1.12 Cultural Info Access	The system shall provide adversary "Cultural" information	16 Potential Requirements
2.2.1 CA Access	The system shall provide access to CA	Accepted
2.2.2 BDA Access	The system shall provide access to BDA	Accepted
2.2.3 MEA Access	The system shall provide access to MEA	Accepted
2.2.4 MA Access	The system shall provide access to MA	Accepted
2.2.5 OAT & Targeting Comms	The system shall provide comms between OAT and Targeting specialist	17 Defective Originating Requirements

<b>Number &amp; Name</b>	<b>Description</b>	<b>Status</b>
2.2.6 Status Updates	The system shall provide updates of status of CA, BDA, MEA, and MA	Accepted
2.3.1 Access to JFC/JFACC Objectives & Effects	The system shall provide access to JFC/JFACC objectives, and desired effects	Accepted
2.3.2 Access to Targeting Strategy	The system shall provide access to targeting strategy	15 Out of Scope Spreadsheet Requirements
2.3.3 Compare Objectives & Effects	The system shall provide views to compare objectives, and desired effects to targeting results	19 Update Requirements to Reflect Analysis
2.4.1 Develop Targeting Strategy	The system shall provide the capability to develop a targeting strategy	15 Out of Scope Spreadsheet Requirements
2.4.2 Promulgate Plan to Team	The system shall provide a means to promulgate plan to team	15 Out of Scope Spreadsheet Requirements
2.5 Compare BDA/MEA to MA	The system shall provide the capability to compare BDA/MEA to MA to assess operational effectiveness	19 Update Requirements to Reflect Analysis
2.6.1 Evaluate BDA for Effects	The system shall provide the capability to evaluate BDA for effects	Accepted
2.6.2 Access to Mission Outcome data	The system shall provide data to mission success, failures, shortcomings	Accepted
2.6.3 Access to Adversary data	The system shall provide access to adversary history, capabilities, resources, and intentions	Accepted
2.6.4 Team BDA Status	The system shall provide ways to update team on status of BDA	15 Out of Scope Spreadsheet Requirements
2.7 Re-attack Recommendation	The system shall provide means to make a re-attack recommendation	Accepted
2.8 TPED Access	The system shall provide access to TPED	16 Potential Requirements
2.9.1 ISR Strategy Access	The system shall provide access to ISR strategy	15 Out of Scope Spreadsheet Requirements
2.9.2 ISR Strategy Modifications	The system shall allow modifications to ISR strategy	15 Out of Scope Spreadsheet Requirements
2.10 Access to PIR/ISR Tasking	The system shall provide access to PIR/ISR tasking	15 Out of Scope Spreadsheet Requirements
2.11 Evaluate ISR strategy	The system shall provide a means to evaluate ISR strategy by evaluating it against PIRs, strategies, and plans	15 Out of Scope Spreadsheet Requirements

<b>Number &amp; Name</b>	<b>Description</b>	<b>Status</b>
2.12 Monitor ISR Objectives	The system shall provide the ability to monitor ISR objectives	15 Out of Scope Spreadsheet Requirements
2.13 ISR Report Access	The system shall provide access to ISR report	Accepted
2.14 ISR Documentation Access	The system shall provide access to ISR documentation	16 Potential Requirements
2.15 Access Multiple sources of Reports	The system shall provide access to multiple sources of reports	Accepted
2.16 Evaluation of PIR	The system shall allow the tracking of PIR status	19 Update Requirements to Reflect Analysis
2.17 Evaluation of MOEs	The system shall allow evaluation of MOEs	Accepted
2.18 Evaluation of Intel Data	The system shall allow evaluation and comparison of summarized intel data with other data	22 Duplicate System Requirements
3.1 Aid Actual Action Evaluation	The system shall aid in tracking actions against the plan	19 Update Requirements to Reflect Analysis
3.2 Environment Affects Plan	The system shall aid in determining the potential effect of weather, terrain, and/or air spaces current/future on possible plan changes	18 Rewording of Requirements
3.3 Determine if Tactical Objectives Achieved	The system shall aid in determining if tactical objectives will be achieved	Accepted
3.4 Determine if Operational Objectives Achieved	The system shall aid in determining if operational objectives will be achieved	Accepted
4.1 Assess Effects on Plan	The system shall allow and aid in the assessment of both direct and indirect effects of air, space and IO on the established plan	Accepted
4.2 Derive Consequences	The system shall allow and aid in the derivation of the intended and unintended consequences of air ops wrt platforms, munitions, culture, population	Accepted
4.3.1 JFACC Report Aids	The system shall allow and aid in determining when and what to report to JFACC	Accepted
4.3.2 Aid determining Plan vs Actual	The system shall aid in identifying deviations from the plan	19 Update Requirements to Reflect Analysis

<b>Number &amp; Name</b>	<b>Description</b>	<b>Status</b>
4.3.3 Evaluate Mission Failures	The system shall aid in determining how mission failures will affect the overall plan	Accepted
4.3.4 Evaluate Mission Successes	The system shall aid in determining the contributions of individual actions to operational effects	19 Update Requirements to Reflect Analysis
4.3.5 Determine if behind plan	The system shall aid in determining if we are behind plan	Accepted
4.3.6 Determine if Ahead Schedule	The system shall aid in determining if we are ahead of schedule	Accepted
4.3.7 Determine if COA effective	The system shall aid in determining if the COA is achieving objectives	18 Rewording of Requirements, 19 Update Requirements to Reflect Analysis
4.4.1 Aid in Report subject	The system shall aid in determining what aspects of the mission should be reported in the daily briefing	21 Additional Out-of-Scope Requirements
4.4.2 Aid in Report contents	The system shall aid in determining how much information to put in presentation	17 Defective Originating Requirements
4.5 Recognize Actionable Changes	The system shall allow and aid in detecting actionable changes in ongoing air ops	19 Update Requirements to Reflect Analysis
4.6 Track Incoming Data	The system shall keep track of incoming data according to the when, who and how	Accepted
4.7.1 Actual Events vs Plan	The system shall aid in determining if actual events coincide with the plan	Accepted
4.7.2 Determine if Plan Achieved	The system shall aid in determining if you are achieving your plan	Accepted
4.7.3 Determine if Plan going wrong	The system shall aid in determining where the plan is going wrong	Accepted
4.7.4 Determine if Plan needs mods	The system shall aid in determining if the plan needs to be modified	Accepted
4.8 Compare Objectives/Tasks to MOEs	The system shall provide the capability to compare objectives and tasks to MOEs to determine effectiveness	Accepted
4.9 Compare Tasks to MOPs	The system shall provide the capability to compare tasks to MOPs to determine effectiveness	Accepted

<b>Number &amp; Name</b>	<b>Description</b>	<b>Status</b>
4.10 Compare Objectives to SIs	The system shall provide the capability to compare objectives to SIs to determine effectiveness	Accepted
4.11.1 Determine if effect implemented	The system shall aid in determine if we actually achieved the effect	18 Rewording of Requirements
4.11.2 Determine persistence of effect	The system shall aid in determining the persistence of the effect	16 Potential Requirements, 18 Rewording of Requirements
4.12.1 Determine Report Contents	The system shall provide the ability to determine what to put in report	Accepted
4.12.2 Aid with Recommendations	The system shall aid in determine recommendations	Accepted
4.12.3 Aid with Confidence	The system shall aid in determining confidence	Accepted
4.12.4 Aid with Status	The system shall aid in determining status	Accepted
5.1 Develop Strat Plan options	The system shall provide a means to develop options to strat plans and compare courses	15 Out of Scope Spreadsheet Requirements
5.2 Compare TT actual vs expected	The system shall allow the comparison of actual to expected results for tactical tasks	Accepted
5.3.1 Identify shortfalls in plans	The system shall identify shortfalls in missions and plans	Accepted
5.3.2 Overcoming shortfall decision aiding	The system shall support the decision making of overcoming the shortfalls	Accepted
5.3.3 Plan Modification decision aiding	The system shall aid in determining if a modification to the plan is needed	Accepted
5.4.1 Corrective Action Feasibility Assessment support	The system shall aid in and allow the assessment of the feasibility of the corrective actions	Accepted
5.4.2 Corrective Action resource analysis	The system shall determine if resources are available for corrective actions	15 Out of Scope Spreadsheet Requirements
5.4.3 Plan Change analysis	The system shall determine what to change	18 Rewording of Requirements
5.4.4 WOE Analysis	The system shall support WOE analysis and modeling	19 Update Requirements to Reflect Analysis
5.4.5 Objective Time Analysis	The system shall determine the time needed to achieve each objective	Accepted

<b>Number &amp; Name</b>	<b>Description</b>	<b>Status</b>
5.4.6 Determine Plan priorities	The system shall determine the priorities for next day according to actual vs planned	15 Out of Scope Spreadsheet Requirements
5.5.1 Predict Corrective Action Effects	The system shall allow and aid in the prediction of effects of the corrective actions on tactical and operational objectives	Accepted
5.5.2 Predict Corrective Action Effects on TO and OOs	The system shall allow and aid in the prediction of the effects that the corrective actions on tactical and operational objectives will have	16 Potential Requirements
5.6.1 Determine Best Plan for Objectives	The system shall determine which plan will "best" accomplish objectives/effects	15 Out of Scope Spreadsheet Requirements
5.6.2 Determine Best Plan for Risks	The system shall determine which plan has less risk associated with it	15 Out of Scope Spreadsheet Requirements
5.7.1 Select Corrective Actions	The system shall allow and aid in the selection of one or more corrective actions	21 Additional Out-of-Scope Requirements
5.7.2 Provide Report Templates	The system shall provide a template for reports	Accepted
5.7.3 Aid in Communications to Plans Team	The system shall allow and aid in the communication of the corrective actions to the plans team	Accepted
5.8.1 Overall Effect limitations	The system shall aid in determining what limitations will have on achieving overall effect	15 Out of Scope Spreadsheet Requirements
5.8.2 Overcome Limitations	The system shall aid in determining how to overcome limitations	15 Out of Scope Spreadsheet Requirements
6.1.1 Receive CA Info	The system shall provide a way to receive combat assessment information	Accepted
6.1.2 Request CA Info	The system shall provide a way to request information	Accepted
6.1.3 New Report Alert	The system shall provide a way to "alert" people that a new report is available	Accepted
6.2 Aid Correlating CA Inputs	The system shall aid in correlating CA inputs to the mission	Accepted
6.3.1 Access to ISR data	The system shall provide access to ISR data (summaries)	Accepted

<b>Number &amp; Name</b>	<b>Description</b>	<b>Status</b>
6.3.2 Rate ISR Data	The system shall provide a way to compare data and rate its validity, reliability, credibility, and efficacy.	19 Update Requirements to Reflect Analysis
6.4.1 Correlate CA data	The system shall aid in correlating CA results with TT, TO, and OO	Accepted
6.4.2 Determine if Objectives met	The system shall aid in determining if objectives are being met	Accepted
6.4.3 Aid determining WOE status	The system shall aid in determining if WOE should be maintained or changed	Accepted
6.4.4 Determine data Correlation/Contradiction	The system shall allow evaluation and comparison of all summarized operational data.	19 Update Requirements to Reflect Analysis
6.4.5 Determine if priorities maintained	The system shall display the priority associated with each objective.	19 Update Requirements to Reflect Analysis
6.4.6 Determine if plan mods needed	The system shall aid in determining if a modification to the plan is needed	Accepted
6.5.1 Display objective progress	The system shall display progress towards objectives	Accepted
6.5.2 Display Plan	The system shall display the Plan	15 Out of Scope Spreadsheet Requirements
6.5.3 Display WOE	The system shall display the WOE	Accepted
6.5.4 Display Mission Time	The system shall display the mission Time (day and hours)	18 Rewording of Requirements
6.5.5 Display Plan vs Actual Tasking	The system shall display planned versus actual tasking	18 Rewording of Requirements
6.5.6 Aid is Objective progress determination	The system shall aid in determining if objectives are being met	Accepted
6.5.7 Aid in WOE status	The system shall aid in determining if WOE should be maintained or changed	Accepted
6.5.8 Aid in Plan Mods	The system shall aid in determining if a modification to the plan is needed	Accepted
6.5.9 Aid determining Plan Progress	The system shall aid in determining if you are ahead/behind plan	Accepted
6.5.10 Aid determining Plan requires additional time	The system shall aid in determining if additional time is needed to achieve operational objectives	19 Update Requirements to Reflect Analysis

<b>Number &amp; Name</b>	<b>Description</b>	<b>Status</b>
6.6.1 Derive intended & unintended effects from CA	The system shall provide a way to derive unintended and intended effects from CA results	Accepted
6.6.2 Aid in Effects Analysis	The system shall aid in determining if effects are being achieved	Accepted
6.6.3 Determine cause of effect	The system shall aid in determining what is causing the effect	Accepted
6.6.4 Aid in Determining duration of effect	The system shall aid in determining how the effect is being achieved and how long it will last	17 Defective Originating Requirements
6.7.1 Monitor CA Channels	The system shall provide a capability to monitor CA channels	15 Out of Scope Spreadsheet Requirements
6.7.2 Organize Data	The system shall organize data	17 Defective Originating Requirements
7.1 Develop Assessment Measures	The system shall support in developing assessment measures for missions	Accepted
7.2.1 Predict COA Events	The system shall aid in the prediction of events that may occur during a COA (play out)	15 Out of Scope Spreadsheet Requirements
7.2.2 Graphical Representation of Battlespace	The system shall provide a graphical representation of the Battlespace	18 Rewording of Requirements
7.2.3 Access Adversary data	The system shall have access to adversary data	Accepted
7.3 Aid in COA development to achieve end state	The system shall provide a means to input end states and aid in the development of COAS to achieve end state	15 Out of Scope Spreadsheet Requirements
7.4 Enter Goal Rationale	The system shall provide access to or a way to input the purpose or rationale as to why the goal is sought	15 Out of Scope Spreadsheet Requirements
7.5.1 Visualize Goal/Objective Actions	The system shall provide visually, a plan or sequence of actions on how the goal or objective is going to be accomplished	15 Out of Scope Spreadsheet Requirements
7.5.2 Access Environmental data	The system shall provide access to environmental information such as weather.	Accepted

Number & Name	Description	Status
7.6 Display Available Resources	The system shall provide access to documents and resources that support the plan.	19 Update Requirements to Reflect Analysis, 21 Additional Out-of-Scope Requirements
7.7.1 Aid in OA info determination	The system shall aid in determining what info is required to support OA	20 Additional Defective Requirements
7.7.2 Allow User Requests	The system shall provide the capability to generate RFI's.	19 Update Requirements to Reflect Analysis, 23 Requirements downgraded from mandatory to potential Requirements
8.1.1 Access Mission Guidance	The system shall provide access to mission guidance	18 Rewording of Requirements
8.1.2 List Team Members	The system shall provide a list of team members	15 Out of Scope Spreadsheet Requirements
8.1.3 Contact Team Members	The system shall provide a means to contact team members	15 Out of Scope Spreadsheet Requirements
8.2.1 Communication Paths	The system shall provide various communication pathways	15 Out of Scope Spreadsheet Requirements
8.2.2 Test Comms	The system shall provide ways to test comms	15 Out of Scope Spreadsheet Requirements
8.2.3 Diagnose Comms	The system shall provide a diagnosis of comms	15 Out of Scope Spreadsheet Requirements
8.2.4 Aid in Choice of comm mode	The system shall aid in the decision making of choosing a comm mode for mission	15 Out of Scope Spreadsheet Requirements
8.2.5 Display Comm Paths	The system shall display various communication pathways	15 Out of Scope Spreadsheet Requirements
8.3.1 Test Comms (duplicate?)	The system shall provide methods to test comms	15 Out of Scope Spreadsheet Requirements
8.3.2 Diagnose Comms(duplicate?)	The system shall provide a diagnosis of problems with comms	15 Out of Scope Spreadsheet Requirements
8.3.3 Problem Checklists	The system shall provide checklists on how to fix problem	15 Out of Scope Spreadsheet Requirements
8.4.1 Provide on-line users	The system shall provide status of who is on-line	15 Out of Scope Spreadsheet Requirements
8.4.2 Provide team summary	The system shall provide a team summary	15 Out of Scope Spreadsheet Requirements

<b>Number &amp; Name</b>	<b>Description</b>	<b>Status</b>
8.5 List comm modes	The system shall provide listings of various comm modes	15 Out of Scope Spreadsheet Requirements
8.6.1 Set up Comm pathways	The system shall enable users to set up comm pathways	15 Out of Scope Spreadsheet Requirements
8.6.2 Pathway Alerts	The system shall allow a alerts to let team members know what the comms pathway being used is	15 Out of Scope Spreadsheet Requirements
8.7 Database Storage of Information	The system shall allow storage of information in a database	Accepted
9.1.1 JAOP supports Plan	The system shall aid in determining how effectively/thoroughly JAOP supports campaign plan	15 Out of Scope Spreadsheet Requirements
9.1.2 JAOP supports OA	The system shall aid in determining how thoroughly and effectively it supports the overall theater campaign plan from the perspective of operational assessment	17 Defective Originating Requirements
9.2 Branch/Sequel Recommendations	The system shall aid in recommending to Strategy Plans Team for branch and/or sequel planning considerations	Accepted
9.3.1 Resource Access	The system shall provide access to various types of resources	17 Defective Originating Requirements
9.3.2 Information Request support	The system shall provide a way to request for information	17 Defective Originating Requirements
9.4.1 Aid Effects Assessment	The system shall aid in determining how to define desired effects for each objective.	19 Update Requirements to Reflect Analysis, 23 Requirements downgraded from mandatory to potential Requirements
9.4.2 Aid Determining Objectives are Met	The system shall aid in determining if objectives are being met	18 Rewording of Requirements
9.5.1 Integrate Multiple Sources	The system shall provide the capability to integrate multiple sources	17 Defective Originating Requirements
9.5.2 Integrate Multiple Collection Strategies	The system shall provide the capability to integrate multiple collection strategies	15 Out of Scope Spreadsheet Requirements
9.5.3 Develop Gathering & Exploiting Procs	The system shall provide the capability to develop procedures for gathering and exploiting	15 Out of Scope Spreadsheet Requirements

Number & Name	Description	Status
9.5.4 Intel Links for JAOP Development	The system shall provide the capability to identify and establish links to info/intel required for JAOP development	15 Out of Scope Spreadsheet Requirements
9.5.5 Intel Links for CA & OA	The system shall provide the capability to identify and establish linkages to info or intel sources that can support CA and OA	Accepted
9.5.6 Develop Collection Requirements	The system shall provide the capability to develop and periodically review/refine collection requirements required by the blue planners	15 Out of Scope Spreadsheet Requirements
9.6.1 Formulate Effects Indicators	The system shall aid in formulating Sis,MOEs, MOPs and Eis for desired effects.	18 Rewording of Requirements, 19 Update Requirements to Reflect Analysis, 21 Additional Out-of-Scope Requirements
9.6.2 Action Completion Threshold Determination	The system shall aid in determining/describing the threshold of change to system elements and/or relationships that indicates completion of the related action	Accepted
10.1.1 Develop OA Plan	The system shall provide the ability to develop an OA plan	15 Out of Scope Spreadsheet Requirements
10.1.2 Compare OA to JAOP	The system shall provide the ability to compare and evaluate the OA plan against the JAOP	15 Out of Scope Spreadsheet Requirements
10.1.3 Perform OA during execution	The system shall provide the ability to perform OA in real time during execution	18 Rewording of Requirements
10.1.4 Mod OA during execution	The system shall provide the ability to modify the OA plan in real time	15 Out of Scope Spreadsheet Requirements
10.1.5 Aid in Decision Making	The system shall aid in the decision making of where and how the plan should be modified	15 Out of Scope Spreadsheet Requirements
10.2 Develop Team member list	The system shall provide the capability to develop team member list(s)	15 Out of Scope Spreadsheet Requirements
10.3 Create Assessment Plan	The system shall allow for the creation of an assessment plan	15 Out of Scope Spreadsheet Requirements
10.4 Integrate JFC & JFACC	The system shall support the integration of both JFC and JFACC guidance and feedback	18 Rewording of Requirements

<b>Number &amp; Name</b>	<b>Description</b>	<b>Status</b>
10.5 Support Effectiveness & Efficiency Evaluation	The system shall support the evaluation of air, space, and IO effectiveness and efficiency	18 Rewording of Requirements
10.6.1 Share Info with Team	The system shall support the capability to share information among team member	19 Update Requirements to Reflect Analysis
10.6.2 Integrate member data in OA Plan	The system shall allow and support the capability to integrate data received from team members into the overall OA plan	15 Out of Scope Spreadsheet Requirements
10.7 Develop Assessment Requirements	The system shall support and allow the development of assessment information requirements	Accepted
10.8.1 Evaluate JFACC Objectives	The system shall support evaluation of JFACC objectives	15 Out of Scope Spreadsheet Requirements
10.8.2 Provide plan access	The system shall allow access to JAOP, MAA, ATO, JIPTL, and OPLAN	Accepted
10.8.3 Provide plan request	The system shall allow the ability to request the: JAOP, MAA, ATO, JIPTL, and OPLAN	17 Defective Originating Requirements
10.8.4 Aid decision between product & Objectives	The system shall aid in the decision making and evaluation between mission results and objectives	18 Rewording of Requirements
10.9 Support Intel source Links	The system shall support and aid in the identification and establishment of any definitive linkages to information or intel sources that can support combat and Operational Assessment functions within the JAOC	15 Out of Scope Spreadsheet Requirements
10.10.1 Refine SOP	The system shall allow for the refinement of standard operation procedures specific to individual duties and responsibilities	15 Out of Scope Spreadsheet Requirements
10.10.2 Assign SOP to individuals	The system shall allow assignment of SOP to individuals	15 Out of Scope Spreadsheet Requirements
10.10.3 Assign Responsibilities to individuals	The system shall allow assignment of roles and responsibilities to individuals	15 Out of Scope Spreadsheet Requirements
10.10.4 ID SOPs and roles	The system shall aid in the identification of SOPs, roles, and responsibilities	15 Out of Scope Spreadsheet Requirements
10.11 Determine Info requirements	The system shall support determination of information requirements associated with assessments	19 Update Requirements to Reflect Analysis

<b>Number &amp; Name</b>	<b>Description</b>	<b>Status</b>
10.12 Request Intel Info	The system shall allow support obtaining Intel and other operational results.	19 Update Requirements to Reflect Analysis
10.13.1 Integrate JFACC OA with JFC	The system shall allow the integration of the OA from JFACC with its counterparts at the JFC level	17 Defective Originating Requirements
10.13.2 Aid in OA Plan Assessment	The system shall aid in the assessment of the OA Plan to ensure a cohesive picture between the campaign plan and the air and space portion of that campaign	15 Out of Scope Spreadsheet Requirements
10.14.1 Aid in determining loss	The system shall aid and support in determining loss	15 Out of Scope Spreadsheet Requirements
10.14.2 Aid in determining cost	The system shall aid and support in determining cost	15 Out of Scope Spreadsheet Requirements
10.14.3 Aid in determining if COA routine	The system shall aid and support in determining if COA is routine or not	15 Out of Scope Spreadsheet Requirements
10.14.4 Aid in determining risk levels	The system shall aid and support in ensuring that standards for routine events are adequate to provide an acceptable level of risk	15 Out of Scope Spreadsheet Requirements
10.15.1 Aid in balancing risk & benefits	The system shall allow and aid in the balancing of risk vs benefits	21 Additional Out-of-Scope Requirements
10.15.2 Aid in eliminating risks	The system shall aid in identifying operational risks.	18 Rewording of Requirements, 21 Additional Out-of-Scope Requirements
10.15.3 Aid in reducing magnitude of risks	The system shall aid in an allow to reduce the magnitude of mission essential risks by applying controls	15 Out of Scope Spreadsheet Requirements
10.16.1 Evaluate roles in EBA process	The system shall allow for the evaluation of roles and responsibilities of components, coalition members, and the DIE agencies in the EBA process	15 Out of Scope Spreadsheet Requirements
10.16.2 Evaluate intelligence requirements	The system shall allow for the evaluation of intelligence collection requirements	15 Out of Scope Spreadsheet Requirements
10.16.3 Evaluate Battle Rhythm for MOE & MP	The system shall allow for the evaluation of battle rhythm to track and continuously review the MOE and MP	15 Out of Scope Spreadsheet Requirements
10.16.4 Plan Troubleshooting	The system shall support plan troubleshooting	18 Rewording of Requirements

Number & Name	Description	Status
10.16.5 Evaluate Methodology for Lack of Progress	The system shall for the evaluation of the methodology to determine whether lack of effects achievement is due to inappropriate actions or monitoring wrong MOE	17 Defective Originating Requirements
11.1.1 Provide actions for Goal	The system shall provide a plan or sequence of actions needed to achieve the goal	15 Out of Scope Spreadsheet Requirements
11.1.2 Modify Plan	The system shall provide a way to modify plan	15 Out of Scope Spreadsheet Requirements
11.2.1 Analyze friendly COGs	The system shall provide the ability to analyze and identify friendly COGs	15 Out of Scope Spreadsheet Requirements
11.2.2 ID COG capabilities	The system shall provide the ability to identify COG Critical capabilities	15 Out of Scope Spreadsheet Requirements
11.2.3 ID COG requirements	The system shall provide the ability to identify COG Critical requirements	15 Out of Scope Spreadsheet Requirements
11.2.4 ID COG vulnerabilities	The system shall provide the ability to identify COG Critical Vulnerabilities	15 Out of Scope Spreadsheet Requirements
11.3.1 Assess Likelihood desired Effects	The system shall provide the capability to assess the likelihood of the desired effects attaining the objective	Accepted
11.3.2 Recommend Success Indicators	The system shall provide the capability to recommend success indicators (MOEs) that will aid in assessment of desired effects (ISR Strategy and planning—third pillar of PBA)	Accepted
11.3.3 Determine unintended Effects	The system shall provide the capability to Determine potential unintended effects	Accepted
11.3.4 Determine Impact of unintended Effects	Assess the impact, or value, of the unintended effects with respect to the JFACC's and the JFC's objectives	Accepted
11.3.5 Unintended Effects Indicators	Recommend indicators that will aid in assessment of unintended effects (ISR Strategy and planning—third pillar of PBA)	Accepted
11.3.6 Determine TO for OOs	The system shall provide the capability to Determine the tactical objectives that will accomplish operational objectives. Determine desired effects (direct and indirect) that will achieve objectives	15 Out of Scope Spreadsheet Requirements

Number & Name	Description	Status
11.3.7 Determine likelihood attaining objectives	The system shall provide the capability to Assess the likelihood of the desired effects attaining the objective. This requires an understanding of the cause and effect relationship (causal linkage)	22 Duplicate System Requirements
11.3.8 Determine Supporting Actions/Tasks	The system shall provide the capability to Determine supporting actions/tasks	15 Out of Scope Spreadsheet Requirements
11.3.9 Refine COAs	The system shall provide the capability to Refine COAs based on priority, sequence, phasing, weight of effort, and matched resources	15 Out of Scope Spreadsheet Requirements
11.3.10 Ensure phases support JFC	The system shall provide the capability to Ensure Phases (and objectives) support JFC phasing, objectives, and end state	15 Out of Scope Spreadsheet Requirements
11.3.11 Sequence Tasks	The system shall provide the capability to Sequence Tasks (Actions) to accomplish objectives and to	15 Out of Scope Spreadsheet Requirements
11.3.12 ID COA risks	The system shall provide the capability to Identify risk areas for each COA	15 Out of Scope Spreadsheet Requirements
12.1 Access Guidance & Objectives	The system shall allow access to guidance and objectives	Accepted
12.2 Develop Guidance & Objectives	The system shall provide the ability to develop guidance and objectives	15 Out of Scope Spreadsheet Requirements
12.3.1 Generate TOS	The system shall allow generation of Tos	15 Out of Scope Spreadsheet Requirements
12.3.2 Provide TOS Template	The system shall provide a template to develop Tos	15 Out of Scope Spreadsheet Requirements
12.3.3 Save Objectives	The system shall provide a way to save the objectives	15 Out of Scope Spreadsheet Requirements
12.4.1 Generate MOEs	The system shall allow generation of MOEs	Accepted
12.4.2 Save MOEs	The system shall provide a way to save MOEs	Accepted
12.4.3 Access MOEs	The system shall provide a way to access old MOEs	21 Additional Out-of-Scope Requirements
12.5.1 Generate OOs	The system shall allow generation of OOs	15 Out of Scope Spreadsheet Requirements
12.5.2 OO Template	The system shall provide a template to develop OOs	15 Out of Scope Spreadsheet Requirements

<b>Number &amp; Name</b>	<b>Description</b>	<b>Status</b>
12.5.3 Save objectives	The system shall provide a way to save the objectives	15 Out of Scope Spreadsheet Requirements
12.6.1 Generate SIs	The system shall allow generation of Sis	21 Additional Out-of-Scope Requirements
12.6.2 Save SIs	The system shall provide a way to save SIs	21 Additional Out-of-Scope Requirements
12.6.3 Access SIs	The system shall provide a way to access old Sis	21 Additional Out-of-Scope Requirements
12.7.1 Generate TTs	The system shall allow generation of TTs	15 Out of Scope Spreadsheet Requirements
12.7.2 Access TPFDD	The system shall allow access to TPFDD	Accepted
12.7.3 Access Adversary Information	The system shall allow access to Adversary system information (IPB, DISUM, INSUM)	Accepted
12.7.4 Summary Friendly Forces	The system shall provide a summary of friendly forces	Accepted
12.8.1 Generate MOPs	The system shall allow generation of MOPs	Accepted
12.8.2 Determine collectable measures	The system shall aid in determining if measures can be collected	15 Out of Scope Spreadsheet Requirements
12.8.3 Determine good measures	The system shall aid in determining if measures are "good"	15 Out of Scope Spreadsheet Requirements
12.8.4 Determine measures collection time	The system shall aid in determining how long it will take to collect measures	15 Out of Scope Spreadsheet Requirements
12.9.1 Multiple COA comparison	The system shall allow comparison of multiple COAs	15 Out of Scope Spreadsheet Requirements
12.9.2 COA best Objectives	The system shall aid in determining which COA will best achieve objectives	15 Out of Scope Spreadsheet Requirements
12.9.3 COA Least Risk	The system shall aid in determining which COA produces less risk	15 Out of Scope Spreadsheet Requirements
12.9.4 COA Ranking	The system shall allow the ranking of COA	15 Out of Scope Spreadsheet Requirements
12.10 COA Analysis methods	The system shall provide various methods to analyze multiple COAs	15 Out of Scope Spreadsheet Requirements
12.11 Prioritize Op Objectives	The system shall allow operational objectives to be prioritized	15 Out of Scope Spreadsheet Requirements

<b>Number &amp; Name</b>	<b>Description</b>	<b>Status</b>
12.12 Sequence Op Objectives	The system shall allow operational objectives to be sequenced	15 Out of Scope Spreadsheet Requirements
12.13 Phase Op Objectives	The system shall allow Operational objectives to be phased	15 Out of Scope Spreadsheet Requirements
12.14 Determine WOE for Op Objectives	The system shall allow Operational objectives weight of effort to be determined	15 Out of Scope Spreadsheet Requirements
12.15 Prioritize TO	The system shall allow TO to be prioritized	15 Out of Scope Spreadsheet Requirements
12.16 Sequence TO	The system shall allow TO to be sequenced	15 Out of Scope Spreadsheet Requirements
12.17 Phase TO	The system shall allow TO to be phased	15 Out of Scope Spreadsheet Requirements
12.18 Determine TO WOE	The system shall allow TO weight of effort to be determined	15 Out of Scope Spreadsheet Requirements
12.19 Prioritize TTs	The system shall allow TT to be prioritized	15 Out of Scope Spreadsheet Requirements
12.20 Sequence TTs	The system shall allow TT to be sequenced	15 Out of Scope Spreadsheet Requirements
12.21 Phase TTs	The system shall allow TT to be phased	15 Out of Scope Spreadsheet Requirements
12.22 Determine TT WOE	The system shall allow TT weight of effort to be determined	15 Out of Scope Spreadsheet Requirements
12.23.1 Effect Priority Display	The system shall display the priority of effects	15 Out of Scope Spreadsheet Requirements
12.23.2 Effect Sequencing Display	The system shall display the sequencing of effects	15 Out of Scope Spreadsheet Requirements
12.23.3 WOE Display	The system shall display the Weight of effort	Accepted
12.23.4 Effect Persistence Display	The system shall display the Persistence of effect	18 Rewording of Requirements
12.23.5 Effect Location Display	The system shall display the location of where effects needs to take place	Accepted
12.24 Determine possible unintended effects	The system shall aid in determining potential unintended effects	15 Out of Scope Spreadsheet Requirements
12.25 Determine Comparison Criteria	The system shall aid in determining comparison criteria	15 Out of Scope Spreadsheet Requirements

<b>Number &amp; Name</b>	<b>Description</b>	<b>Status</b>
12.26 COA rating	The system shall allow the ability to rate each COA against the criteria	15 Out of Scope Spreadsheet Requirements
12.27 COA recommendation	The system shall allow the ability to recommend the highest rated COA	15 Out of Scope Spreadsheet Requirements
12.28 COA Modification	The system shall provide the ability to modify COA	15 Out of Scope Spreadsheet Requirements
12.29 STTM Development	The system shall provide the ability to develop the STTM	17 Defective Originating Requirements
13.1.1 Wargame COAs	The system shall provide the capability to wargame COAs	15 Out of Scope Spreadsheet Requirements
13.1.2 Provide COA Framework	The system shall provide a basic framework for the development of the COAs	15 Out of Scope Spreadsheet Requirements
13.1.3 COA Outcome Playback	The system shall "play" the outcome of COAs	15 Out of Scope Spreadsheet Requirements
13.1.4 ID COA Weakness	The system shall identify weaknesses in the COA	15 Out of Scope Spreadsheet Requirements
13.1.5 Display Friendly Losses	The system shall display friendly losses	Accepted
13.1.6 Display Effects	The system shall display both desired effects and undesired effects	Accepted
13.1.7 Display Collateral Damages	The system shall display collateral damages based on COAs	21 Additional Out-of-Scope Requirements
13.1.8 Display COA options	The system shall display options to let user choose the best COAs	15 Out of Scope Spreadsheet Requirements
13.1.9 Reporting Mechanism	The system shall provide a reporting mechanism	17 Defective Originating Requirements
13.1.10 COA Modifications	The system shall allow modifications to COAs	21 Additional Out-of-Scope Requirements
13.2 COA Recalculations on Changes	The system shall recalculate the probability of attaining commanders intent as well as the changes in the criteria values when COAs are modified	21 Additional Out-of-Scope Requirements
13.3 Creation of Sequels	The system shall allow the creation of sequel plans that allow friendly forces to capitalize on achievement of objectives and desired effects	15 Out of Scope Spreadsheet Requirements

Number & Name	Description	Status
13.4.1 Aid in Undesired Effects Assessment	The system shall support and aid in the assessment of the likelihood of Undesired Effects occurring given the likely enemy reactions	Accepted
13.4.2 Adversary History	The system shall provide the history of adversary	Accepted
13.4.3 Adversary Allies	The system shall provide information concerning the adversary allies	Accepted
13.4.4 Adversary Capabilities	The system shall provide information concerning adversary capabilities	Accepted
13.4.5 Adversary Intent	The system shall provide information concerning adversaries intent	Accepted
13.4.6 Enemy Actions & Undesired Effects	The system shall aid in determining how might the enemy act to produce Undesired Effects.	15 Out of Scope Spreadsheet Requirements
13.4.7 Consequence of Undesired Effects	The system shall aid in considering the consequences of all known Undesired Effects.	Accepted
13.4.8 Undesired Effects mitigation	The system shall recommend changes that mitigate the risk of causing undesired effects	15 Out of Scope Spreadsheet Requirements
13.4.9 Create Branch Plans	The system shall create basic branch plans that address enemy reactions and mitigate risks of unintended and undesired effects	15 Out of Scope Spreadsheet Requirements
13.5.1 Visualize COA operations	The system shall aid in the visualization on how operations will unfold based on the selected COA	Accepted
13.5.2 COA Path	The system shall aid in determining if COA path is correct	15 Out of Scope Spreadsheet Requirements
13.5.3 COA Path Mods	The system shall aid in determining if COA needs to modified	19 Update Requirements to Reflect Analysis
13.5.4 COA Mission Analysis	The system shall aid in determining if COA will achieve objectives.	19 Update Requirements to Reflect Analysis
13.5.5 COA Path Effects	The system shall aid in determining undesired/desired effects along pathway	20 Additional Defective Requirements
13.6.1 COA Commanders Intent	The system shall aid in the comparison of COA options to commanders intent to ensure intent is being met	15 Out of Scope Spreadsheet Requirements

Number & Name	Description	Status
13.6.2 COA Measures	The system shall aid in determining if COAs are measurable for assessment	20 Additional Defective Requirements
13.7.1 Mission Archives Access	The system shall provide access to archival data concerning past mission	Accepted
13.7.2 Mission Archives Search	The system shall provide a way to search for archives	Accepted
13.7.3 Data Archive Creation	The system shall provide a way to archive data	Accepted
13.7.4 Archive Search Tips	The system shall provide tips on how to search for archives	15 Out of Scope Spreadsheet Requirements
13.8.1 Building Timeline	The system shall aid in building a timeline to identify when certain objectives are projected to occur	20 Additional Defective Requirements
13.8.2 Event Occurrence Plotting	The system shall plot and aid in determining when events should occur	Accepted
13.8.3 Event Complete Plotting	The system shall plot and aid in determining when events should be complete	Accepted
13.8.4 Event Sequencing and Plotting	The system shall plot and aid in determining what events precede others	Accepted
13.9 COA Wargaming Analysis	The system shall aid in identifying advantages and disadvantages of each COA based on wargaming	15 Out of Scope Spreadsheet Requirements
13.10.1 COA Refinement	The system shall allow refinement of each COA	15 Out of Scope Spreadsheet Requirements
13.10.2 Develop likely enemy reactions	The system shall aid in developing enemy's most likely and most dangerous reactions based on recommendations, sequel and branch plans	Accepted
13.10.3 FrOB Validation	The system shall aid in validating FrOB based on COA wargaming	15 Out of Scope Spreadsheet Requirements
13.10.4 Force Mix Recommendation	The system shall recommend a different force mix	15 Out of Scope Spreadsheet Requirements
13.10.5 Resource Ranking	The system shall aid in and allow the ranking of resources according to expected contributions of friendly and adversary forces to achieving desired effects	15 Out of Scope Spreadsheet Requirements

Number & Name	Description	Status
13.11 Projected Task Timeline	The system shall display when certain tasks are projected to occur	19 Update Requirements to Reflect Analysis
13.12 Projected Effect Timeline	The system shall display when effects are projected to occur	19 Update Requirements to Reflect Analysis
13.13 Analysis Linkage Development	The system shall aid in developing linkage(s) to support a timely and accurate analysis	15 Out of Scope Spreadsheet Requirements
14.1.1 Objective Data access	The system shall have access to Objectives	Accepted
14.1.2 Task Data access	The system shall have access to Tasks	Accepted
14.1.4 Task & Objective access	The system shall allow have access to all measures associated with tasks and objectives	Accepted
14.1.5 Measure Changes	The system shall allow changes to be made to measures	Accepted
14.2 View AOD data	The system shall provide the capability to view JFACC objectives, tasks, and their associated measures, and the AOD	18 Rewording of Requirements

**This page blank intentionally.**

# **APPENDIX D**

## **GEO-SPATIAL EFFECTS VISUALIZATION (GEV)**

### **Concept Design Principles: Map Displays**

---

**Operational Effects Assessment Visualization Tool  
(OEAVT)**

# **Concept Design Principles: Map Displays**

**Date: 27 January 2006**

**Developed for internal use at SAIC**

**Prepared by: Science Applications International  
Corporation  
4031 Colonel Glenn Highway  
Beavercreek, Ohio 45431**

**Contract No: FA8650-04-C-6475**



**OEAVT Concept Design Principles: Map Displays**

**Change History**

<b>Version</b>	<b>Date</b>	<b>Description</b>
1.0	27 Jan 2006	Initial Release

## List of Figures

---

<b>1 Scope &amp; Purpose</b>	<b>1</b>
<b>2 Referenced Documents</b>	<b>1</b>
<b>3 Functional Use of maps within OEAVT</b>	<b>2</b>
3.1 Map Display Constraints .....	3
3.2 Visual Design Guideline for Maps .....	4
3.2.1 Map Projection and Datum .....	4
3.2.2 Display of Terrain.....	5
3.2.3 Display of land/water features: limited color pallet .....	8
3.2.4 Use of overhead imagery to depict land/water .....	9
3.2.5 Scale issues in map graphics and imagery.....	10
3.2.6 Use of selectable layers .....	13
3.2.7 Display of time: animation .....	14

## List of Figures

---

3-1 Example of an un-projected versus a projected map	4
3-2 An un-projected rendering of the ETOPO-5 dataset..	5
3-3 An orthographic projection rendering of the same ETOPO-5 data set...	5
3-4 Shaded Relief.	6
3-5 Examples of terrain depicted by contour lines...	7
3-6 Gray scale encoding of elevation	7
3-7 Color coded depictions of terrain elevation	8
3-8 Land topographic heights and water bathometric depths portrayed in an example limited range pallet.	9
3-9 Comparison of 1:24000 map feature density to 1m resolution aerial photograph.	11
3-10 Reduced pallet rendering of photographic images improves legibility of overlays/symbols	12
3-11 Depiction of time in thumbnails, from Tufte, 1997.	14

## List of Tables

---

3.0 Summary of Map Display Design Recommendations for OEAVT

2

## 1 Scope & Purpose

This document defines the underlying principles and derived guidelines used to generate the OEAVT concept displays that include cartographic display elements (i.e., maps) either as a primary display or a contextual background.

## 2 References

- Snyder, John P. 1987. *Map projections: a working manual*. USGS Professional Paper 1395. Washington, DC: United States Government Printing Office
- Tufte, Edward R. 1997. *Visual Explanations: Images and Quantities, Evidence and Narrative*. Cheshire, CT: Graphics Press
- Tufte, Edward R. 2001. *The Visual Display of Quantitative Information, 2<sup>nd</sup> Ed.* Cheshire, CT: Graphics Press
- Hoffman, Gernot, 2005. *CIE Lab Color Space*  
<http://www.fho-empden.de/~hoffmann/cielab03022003.pdf>

MIL-STD-2525B w/CHANGE 1, Common Warfighting Symbology, 1 July 2005

### 3.0 Functional use of maps within OEAVT

Maps in OEAVT are used to:

- Place symbolic information overlays in geographic context

Display spatial relationships between symbolic elements Maps in OEAVT are specifically not used to:

- Perform quantitative evaluation of terrain (e.g., contour lines)
- Display precise, quantifiable spatial relationships appropriate for targeting, specific target BDA, or detailed planning of operational movements.

To meet these functional objectives in OEAVT, several design principles for map displays are defined in section 3. Table 3.0 summarizes these design recommendations.

**Table 3.0 Summary of Map Display Design Recommendations for OEAVT**

#	Function	Recommendation	Comment
3.1	Display size & colors	Single display, 1024 x 768, millions of colors	Should support multiple displays and larger monitors if available.
3.2.1	Map datum	WGS-84	
3.2.1	Projection	Always use projected map displays	
3.2.1	Projection: large-area, mid-latitude	Lambert Conformal Conic	Typically 30 - 80 degrees
3.2.1	Projection: large-area, equatorial	Mercator	Typically $\pm 30$ of equator
3.2.1	Projection: large-area, polar	Universal Polar Stereographic	Typically above 80 degrees
3.2.1	Projection: small-area (except polar)	Universal Transverse Mercator	
3.2.1	Projection: special use	Orthographic	Used for planetary hemisphere views
3.2.2	Depiction of terrain	Shaded relief	Preserve color space and line graphics for data other than terrain.
3.2.2	Terrain vertical exaggeration	Avoid. Limit to 3x if needed, and label the exaggerated graphic.	
3.2.2	Terrain relief lighting	Always within 45 degrees of directly "above" from the user's point of view.	For north-up maps, the light source for shaded relief will be located between NW and NE.
3.2.3	Map background color pallet	Use a color pallet $>50$ "L" in the CIE $L^*a^*b$ color space for map background colors such as land cover and water combined with shaded relief.	Goal is visual contrast between background map and overlays in both displays and printed copy.
3.2.4	Use of photographic imagery	Use only for high-detail, small area maps.	
3.2.5	Imagery metadata	OEAVT displays should maintain the identity metadata of display imagery.	
3.2.5	Photographic imagery rendering	Use a reduced pallet of $L < 50$ .	

¶	Function	Recommendation	Comment
3.2.6	Graphic layers	Display order and appearance of graphic layers should be user adjustable.	
3.2.6	Graphic layers	Order of layers in a control list should reflect the display order of precedence (e.g., upper layers may obscure lower layers)	
3.2.6	Terrain layer	Should always be the lowest layer	
3.2.6	Areal tint layer	Next layer above terrain. Depicted as reduced pallet transparent tints over terrain shaded relief layer. Content is user selectable.	
3.2.6	Photographic layer	Next layer above areal tint layer.	Use of photographs obscures areal tints and shaded relief.
3.2.6	Map overlay selectable parameters	Stacking order, Presence, De-Clutter, Areal layer content, Overlay color/symbol, gridlines.	
3.2.6	Map scale	Scale should always be displayed using units of meters or kilometers	
3.2.6	North Arrow	No arrow should be used.	All maps displayed North-up.
3.2.7	Display of time	Continuous animation of symbols or time-slice snapshots.	
3.2.7	User animation controls	Playback speed and direction.	
3.2.7	Symbols in a time-referenced display	Thumbnails, time scale, indication of time depicted in main display	Tufte example illustration.

### 3.1 Map display constraints

Map displays in OEAVT are generated using COTS computers typically running Windows 2000 or Windows XP operating systems. The typical OEAVT user will have two desktop screens available, but may be limited to a laptop computer with a single display.

- The map display should be designed to require no more than 1024 x 768 pixel display, with 24 bit RGB color (e.g., millions of colors).
- Ideally, the map display will retain full functionality if displayed as a sixteen-bit color-mapped display (e.g., thousands of colors).
- The map should support presentation as a window within the display constraints identified above.
- The map display should support display on a separate monitor, using all or part of the resolution of that monitor.
- The map display should support display on larger format monitors, e.g. 1280 x 1024 and larger without adverse effects.

## 3.2 Visual Design Guideline for Maps

### 3.2.1 Map Projection and Datum

A map inherently distorts the spatial relationship of objects on a spherical surface. The degree of the distortion depends upon the scale of the map, the latitude of the map projection center, and the selected map projection. Maps should never be displayed in an un-projected format. See figure 3-1 for an example of Europe and Western Asia displayed both un-projected, and projected using a Lambert Conformal Conic projection. All OEAVT map displays should be referenced to the WGS-84 datum horizontal datum and mean sea level for the vertical datum.

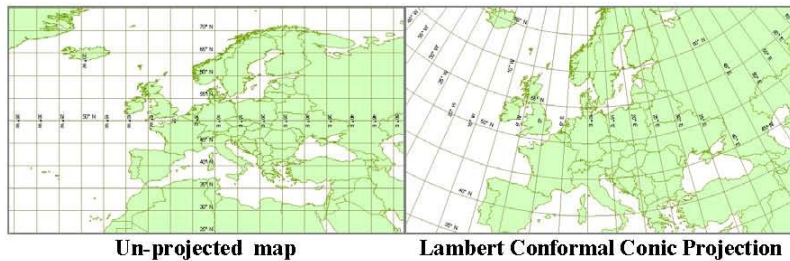

**Figure 3-1: Example of an un-projected versus a projected map.**

The following map projections are recommended for use in OEAVT, as the projections are already in use in operational graphics:

**Lambert Conformal Conic:** This projection is recommended for small-scale (large area) mid-latitude maps, as well as large-scale (small area) maps. The standard parallels should be selected to minimize distortion across the selected display. This is the standard projection for most mid-latitude small scale graphics such as Joint Operational Graphics (JOGs) created by the National Geo-Spatial Intelligence Agency (NGA).

**Mercator:** This projection is recommended for small-scale maps in equatorial regions. Outside of equatorial regions, Mercator is a special-use projection due to large distortions.

**Universal Transverse Mercator (UTM):** This projection is recommended for large-scale (small area) maps when correlation with overlays inherently expressed in UTM grid coordinates is required (e.g., phase lines, etc.).

**Universal Polar Stereographic Projection:** This projection is recommended for both large-scale and small-scale maps of the polar regions north of 84° latitude or south of -80° latitude.

**Orthographic:** This projection may serve as a special-use map display of planetary hemispheres. Especially if animated for user selection of the projection center, the orthographic projection is useful for overview and selection of more specific areas of interest to be displayed by one of the other recommended projections. Figures 3-2 depicts an example of an un-projected rendering of topographic height and bathymetric depth, while figure 3-3 depicts an example of the Orthographic projection (single hemisphere) from the same dataset.

Additional information on these projections including a complete mathematical definition may be found in Snyder, 1987.

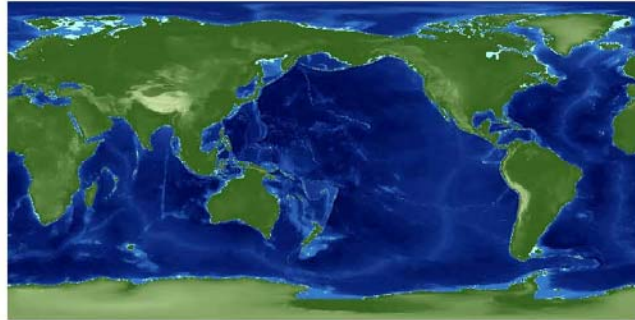

**Figure 3-2: An un-projected rendering of the ETOPO-5 dataset (topographic height and bathymetric depth on a 5 arc minute spacing). Note the extreme distortion in the polar regions. Only the equator is true-scale.**

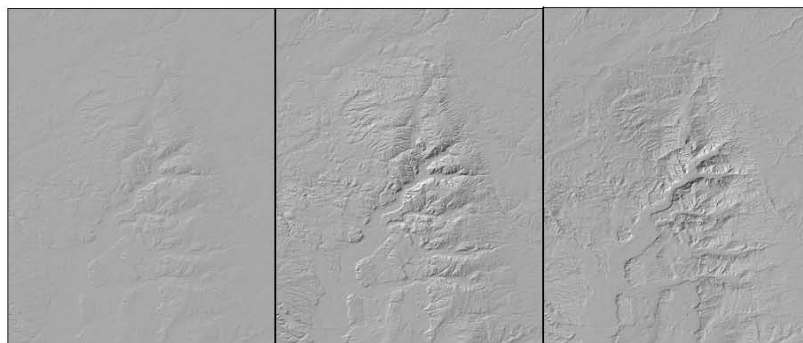

**Figure 3-3: An orthographic projection rendering of the same ETOPO-5 data set with the projection centered on North America.**

### **2.2.2 Display of terrain**

Military planners must consider the impact of terrain on operations. Although OEAVT displays will not be used for detail planning, major terrain features and characteristics must be depicted in order to simplify correlation with other operational map graphics used in the planning and evaluation process. Several methods of terrain depiction are identified below.

**Shaded Relief:** This method is recommended for OEAVT displays, as it allows qualitative assessment of gross terrain features at a glance. A shaded relief map in gray scale allows for the shading to be merged with overlay color tints containing non-terrain information that may be needed to enhance assessment such as land cover, precipitation, population density or ethnicity among others. Some cautions are in order for the implementation of shaded relief terrain maps. The light source must appear to be overhead to the observer less terrain features appear inverted. For a North-up map, this means a light source positioned between NW and NE. Also, vertical scale exaggeration may be used, with caution, to enhance terrain relief. It is recommended that vertical exaggeration be limited to no greater than 3x, and applied to all map displays on a user-selected on-off basis. Selectively scaling one region and not another will lead to confusion regarding actual terrain. Examples appear in figure 3-4 below.



**1x NW light source      3x Scale, NW light source      3x Scale, SE light source**  
**Figure 3-4: Shaded Relief.** The figures above depict hills in generally flat Ohio terrain (roughly 300' hilltop to valley floor maximum difference). The figure at left depicts lighting from the North West (above, left relative to the reader), and no vertical exaggeration of the terrain. The center figure depicts lighting from the North West, and a 3x vertical exaggeration. Note the improved perception of hills to valleys in the middle figure. The right figure depicts lighting from the South East (from below-right relative to the reader), and 3x vertical exaggeration. Note the reversal of the perceived high/low relationship with lighting from "below". The central valley apparent (correctly) in the center figure is perceived as a sinuous plateau in the right figure.

**Contour Lines:** This method allows precise, quantitative evaluation of terrain. Contour lines are frequently combined with shaded relief on tactical operations maps in an effort to combine at-a-glance qualitative understanding of the terrain features with the ability to perform quantitative analysis. Examples of contour lines with and without relief shading are depicted in figure 3-5. Contour lines in either form are not recommended for OEAVT displays as the precision is unnecessary, and the lines add distracting visual clutter to necessary overlays.

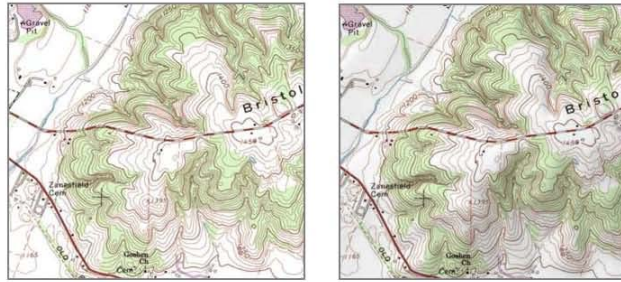

**Figure 3-5: Examples of terrain depicted by contour lines on a USGS 7.5' series topographic map. The left figure depicts contour lines only, the right figure adds shaded relief to aid qualitative understanding. The terrain depicted is a detailed view of the hill/valley terrain previously depicted in shaded relief.**

Gray scale coded elevation: This method is difficult for most users to interpret, and its use is not recommended for OEAVT. The figure 3-6 depicts a gray-scale encoding of elevation, and a corresponding contour map.

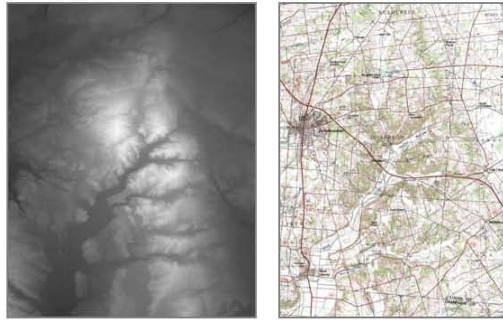

**Figure 3-6: Gray scale encoding of elevation is depicted to the left of a contour map of the same region. Note that the contour map depicts the central portion of the gray scale, not the entire area. The terrain depicted is the same region of hill/valley terrain previously depicted in shaded relief.**

Color-coded elevation: This method is especially useful when combined with shaded relief. The designer is cautioned that local optimization of color pallet to best reveal subtle terrain changes can cause confusion when the same pallet is re-used for different terrain. If color-coded terrain is used, then an absolute terrain elevation to color pallet capable of depicting world-wide elevations should be used, with shaded relief added to enhance the perception of terrain. An unsaturated (e.g. pastel) pallet is recommended for OEAVT maps, following the design principle of minimum differences described in Tufte, 2002. This unsaturated reference background improves the readability of more saturated overlays of effect evaluation symbology.

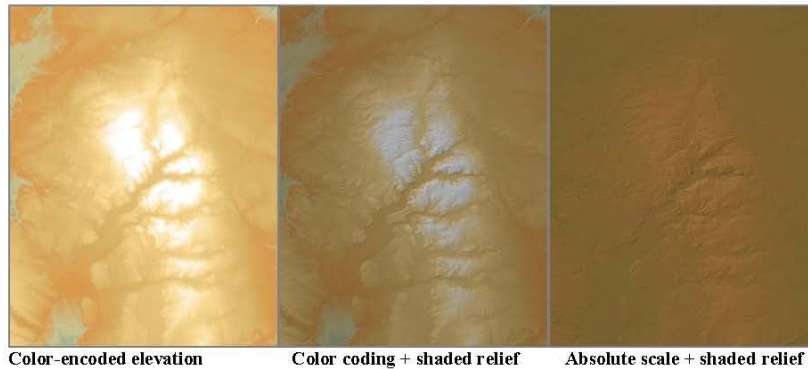
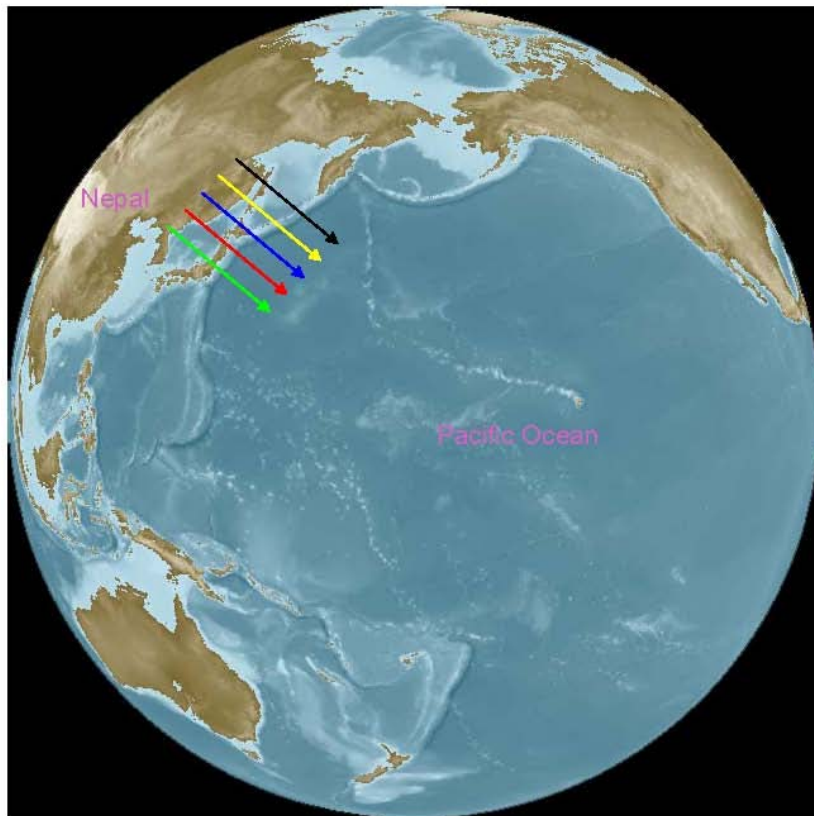

**Figure 3-7: Color coded depictions of terrain elevation.**

The three panes of figure 3-7 depict terrain elevation encoded by color. The left figure depicts a color encoding scale optimized for a single region (uses the entire range of the pallet for the elevations present). The center figure depicts the addition of shaded-relief to the optimized encoding scale. The right figure depicts an absolute color encoding scale (optimized for world-wide elevations), combined with shaded relief.

### 2.2.3 Display of land/water features: limited color pallet

Water features should be depicted in a blue pallet to provide color-contrast to land features, which are traditionally depicted in a pallet of browns or greens. The blue saturation selected for water features should be scaled mid-range to the value of the land pallet. If bathometric depths or other variations must be expressed within the water layer, it is recommended that an unsaturated (e.g., pastel) color pallet be used for both land and water. Ideally, the darkest color in both land and water pallets will not drop below a value for “L” of fifty as measured in the CIE L\*a\*b color space (where L expresses “psychometric brightness” in a scale from zero (maximum darkness) to 100 (maximum lightness)). Figure 3-8 depicts a such a pallet depicting land/water contrasts.



**Figure 3-8: Land topographic heights and water bathymetric depths portrayed in an example limited range pallet. Such a pallet reserves saturated colors for overlays, as depicted by the overlay arrows. Note they remain distinct despite crossing a wide range of pallet values. Picking a text similar in perceived brightness but distinct in color distinct from either the land or water pallets preserves the readability of text without overwhelming visual clutter.**

#### **2.2.4 Use of overhead imagery to depict land/water**

Projected overhead imagery may form the map base display. This is especially useful for large-scale (small area) depictions where cultural features such as buildings, earthworks and roads become more descriptive of the operational “terrain” than bare-earth terrain depictions generated by databases. If used as a base map, the saturation of imagery should be reduced to an L value of less than fifty. In general, panchromatic imagery is

preferred over multi-spectral imagery for use as a background map due to reduced visual clutter.

### 2.2.5 Scale issues in map graphics and imagery

For small scales, reference maps consisting of symbolic abstractions of physical and cultural features are recommended over photographic images such as CIB. This is due to the presence of visual clutter in small scale photographs that impede understanding of relevant terrain features, as depicted in figure 3-9 below by a 1:24000 map rendering (the largest scale map likely to be encountered in military operations or derived from NGA map databases), and the corresponding area in a one meter aerial photograph.

At even larger scales, depending upon terrain feature density, symbolic maps become less useful as more and more of the displayed area is occupied by featureless white space isolated symbols without adequate spatial reference. At very large scales, typically less than 1:50000 for suburban or urban terrain but perhaps up to 1:100,000 for more featureless desert terrain, photographic depictions become preferable as the increased content provides more useful reference clues. In the illustration below, a small portion of a built-up area is identified using a red rectangle box. This area is depicted enlarged as a one-meter resolution photographic image in figure 3-10.

Note that for this small area, the photographic image provides a more detailed understanding of the selected area, without so much detail as to be overwhelming as in the smaller scale examples. If photographic images are selected to depict terrain features, a limited pallet will again enhance the readability of overlays that represent the core content of OEAVT displays.

If imagery is presented, there is the risk that assessors will attempt to exploit the content of the imagery (e.g., is that runway still serviceable, is that SAM site operational, etc.), rather than use the image simply as a spatial reference. This is inappropriate and potentially dangerous. OEAVT displays of imagery, especially intelligence imagery, should always contain metadata that maintains the identity of the source image.

The metadata allows retrieval of the source image so that it can be exploited using appropriate tools and methods if necessary. Excellent tools exist for the detailed exploitation of imagery; an assessment display should not lure the user into using a background photographic image for exploitation rather than reference. The use of a reduced contrast pallet as depicted in the figure below both aids readability of overlays and discourages inappropriate use (attempted exploitation) of the photographic image.



**Figure 3-9: Comparison of 1:24000 map feature density to 1m resolution aerial photograph. Note that the reduced visual information on the map enables more rapid comprehension of key terrain and cultural features.**



**Figure 3-10: Reduced pallet rendering of photographic images improves legibility of overlays/symbols, using the image for spatial reference, not exploitation.**

## 2.2.6 Use of selectable layers

OEAVT maps should be displayed in layers, with “upper” layers capable of obscuring symbols on lower layers. Layers displayed should always be defined in a map legend. The arrangement of layers should be user selectable with the exception of three permanent “area” feature layers making up the base map as depicted below (base layers are underlined):

```
>> Upper user-selectable/user-stackable symbol layers
>> “ “
>> “ “
>> “ “
..
>> Photographic background layer (obscures lower layers if selected).
    The content for this layer may be derived from standard NGA products
    such as Controlled Image Base (CIB), or from operational imagery.
>> Areal “tint” layer to shaded relief (non-obscuring). Note that the
    content and presence of this layer is user selectable.
>> Terrain base-layer, typically depicted as shaded relief, and derived
    from standard NGA sources (e.g., DTED).
```

Layered map overlays should be user selectable for the following parameters:

- Stacking order: Where symbols on user-defined layers may obscure symbols on lower layers and the base layers. The order of layers in the map legend should correspond to the stacking order.
- Presence: Layers may be turned on/or off. If turned off, they should be removed (or grayed) in the map legend.
- De-clutter: A de-clutter capability should be provided to allow all other layers other than the selected layer and the base layers) to be temporarily removed or grayed (visually minimized). The de-cluttered layer should not be obscured by any other map layer.
- Areal tint layer content: The tint applied to the shaded relief terrain may depict a wide range of information: natural and cultural land cover classification, population density, ethnic and religious populations, sensor /threat coverage, weather, etc. The tints applied should provide a default pallet, with further user-adjustment possible.
- Overlay color/symbol: A pallet of over-lay colors/symbols compliant with MIL-STD 2525B should be provided for each point and line feature overlay. Each symbol type should also have a selectable “subdued” color, derived from its standard color. The design intent of the subdued color is to continue to have the context of the selected symbol present on the display, but at a reduced clutter level.
- Gridlines: Gridlines in either latitude/longitude or UTM Northing/Easting should be selectable on/off and available in both contrasting and subdued colors. All gridlines should include numeric values. Gridline spacing should allow both an auto-spacing (dividing the map into a 4x4 grid), and user-defined grid line spacing intervals for both latitude/longitude or UTM.

## GIS Environment Trade Study

---

Operational Effects Assessment Visualization Tool  
(OEAVT)

# GIS Environment Trade Study

Date: 9 March 2007

Developed for:  
AFRL/HECP  
2255 H Street  
Wright- Patterson AFB, OH 45433-7022

Prepared by: Science Applications International Corporation  
4031 Colonel Glenn Highway  
Beavercreek, Ohio 45431

Contract No: FA8650-04-C-6475



**Purpose:**

This trade study examines the functional capability of several candidate mapping applications against the notional functional requirements of the OEAVT Geospatial Effects Visualization (GEV). Both open-source tools familiar to the OEAVT team and commercial mapping tool kits are examined.

The trade study has been tailored, at customer request, to allow a similar comparison against the COA Sketch mapping requirements (COA Sketch is a Systems Research Associates development also conducted by AFRL). The goal of this tailoring is to examine the suitability of a single mapping application to meet both OEAVT and COA Sketch needs.

**Scope:**

The trade study recommendation is limited to the initial, prototype development and deployment of the GEV.

## Mapping Tools - Functional & Requirement Comparison

**Table 1:** Functions mapped as **M**, Mandatory, **HD** Highly Desired, **D** Desired, and **NS**, Not Significant to program.

Feature	OEA VT GEV	COA Sketch
<b>GUI / Interface Capabilities</b>		
1. Configurable GUI	<b>M</b>	
2. Able to embed into separate applications	<b>M</b>	
3. 3D interface	<b>NS</b>	
4. 3D terrain rendering	<b>NS</b>	
<b>Software Libraries</b>		
5. C++ SDK	<b>NS</b>	
6. Java SDK	<b>HD</b>	
<b>Drawing Capabilities</b>		
7. Raster	<b>M</b>	
8. Polygons	<b>M</b>	
9. Polylines	<b>M</b>	
10. Icons	<b>M</b>	
<b>Layers</b>		
11. Visibility	<b>M</b>	
12. Draw order	<b>M</b>	
13. GUI Controls	<b>HD</b>	
<b>File Types</b>		
14. ESRI (GIS shape data)	<b>HD</b>	
15. DTED	<b>M</b>	
16. CADRG and CIB	<b>M</b>	
17. Basic Raster (JPG,BMP)	<b>HD</b>	
18. Comma Separated (CSV)	<b>D</b>	
19. KML (vector and raster in XML format)	<b>D</b>	
<b>Projections</b>		
20. Orthographic	<b>D</b>	
21. Equal Arc (LLXY/CADRG)	<b>NS</b>	
22. Mercator	<b>NS</b>	
23. Gnostic	<b>NS</b>	
24. Polar Stereographic	<b>HD</b>	
25. Lambert Conformal Cone	<b>HD</b>	
26. UTM/MGRS	<b>HD</b>	
<b>General Performance and Dependencies</b>		
27. Speed	<b>HD</b>	
28. Reliability	<b>HD</b>	
29. Validated Algorithms	<b>HD</b>	
30. Internet Independent	<b>HD</b>	

## **Elaboration on Mandatory and Highly Desired features for GEV:**

### **Mandatory:**

**Configurable GUI:** GEV concepts are layer-based, with a customized GUI providing “at a glance” understanding/access to the operational hierarchy as well as control over the displayed graphics.

**Able to embed into separate applications:** The mapping engine is exactly that – a display tool. The GEV has underlying capabilities for which the map is only a visualization.

**Drawing Capabilities – Raster:** Essential for rendering base map data, as it is commonly provided as CADRG, can be rendered DTED, or may be overhead imagery.

**Drawing Capabilities – Polygons:** Essential for efficiently displaying and editing operating and assessment regions and other areal features.

**Drawing Capabilities – Polylines:** Essential for depicting boundaries, phase lines, road and other networks, etc.

**Drawing Capabilities – Icons:** Essential for point-feature depiction. GEV will employ predefined assessment symbols places as icons on the base map.

**Layer Control – Visibility:** Essential for de-clutter of complex operations. Should be directly controllable via the GUI.

**Layer Control – Draw Order:** Fundamental to the visualization concept of the GEV. In appropriate draw order can result in concealing assessment information leading to erroneous interpretation.

**DTED, CADRG, CIB:** DTED, CADRG and CIB are all raster formats and are the standard base-map graphics in use in the DoD. These are essential for base-map layers.

### **Highly Desired:**

**Java SDK:** Allows multi-platform development for both legacy UNIX or Windows deployment within the AOC.

**Read ESRI Shape files:** A GIS standard for the interchange of linear and areal features such as roads, political boundaries, etc.

**Read basic raster data:** JPEG and other commercial raster formats are desired for ingesting pre-processed raster layers edited by external tools.

**Polar Stereographic Projection:** Standard projection used by the USAF for high-latitude map displays.

**Lambert Conformal Conic Projection:** Standard projection used by the USAF from mid-latitude to equatorial maps, including GNC, JNC, JOG and TPCs. Already familiar to USAF rated personnel.

**UTM/MGRS:** The UTM projection, especially as implemented in the Military Grid Reference System, would simplify visualizing joint operations that were US Army-centric. USA fire-support and coordination lines are typically given solely in MGRS.

**Speed:** Especially critical for user acceptance as the data becomes more complex in large operations.

**Reliability:** Essential to user acceptance. Nobody likes using tools that crash and lose work.

**Validated Algorithms:** For precision mapping work, this is essential, and for many GIS implementation would be mandatory. For the GEV, since terrain analysis is not an expected user function and only general interpretation of the geospatial environment is needed, this is downgraded to highly desirable.

**Internet Independent:** A resiliency issue based on the threat of network attack. While collaboration is also highly desired, the ability to continue using the application from local cached data is viewed as highly desirable.

**Table 2:** Feature Comparison by GIS Tool

KEY	
OM	OpenMap
AG	ArcGIS (ESRI through C/JMTK)
OS	OSSim
GEp	GoogleEarth pro
GEb	GoogleEarth basic
GM	Google Maps
JV	JView
uD	uDig

**Table 2: Feature Comparison by GIS Tool**

Feature	OM	AG	OS	GEp	GEb	GM	JV	uD
<b>GUI / Interface Capabilities</b>								
1. Configurable GUI	X	X					X	
2. Able to embed into separate applications	X	X						
3. 3D interface				X	X			
4. 3D terrain rendering				X	X		X	
<b>Software Libraries</b>								
5. C++ SDK		X	X					
6. Java SDK	X	X					X	
<b>Drawing Capabilities</b>								
7. Raster	X	X	X	X	X		X	X
8. Polygons	X	X		X	X			X
9. Polylines	X	X		X	X	X		X
10. Icons	X	X		X	X	X		X
<b>Layers</b>								
11. Visibility	X	X	X <sup>3</sup>	X	X			X
12. Draw order	X	X	X <sup>3</sup>	x <sup>1</sup>				X
13. GUI Controls	X	X		X	X			X
<b>File Types</b>								
14. ESRI (GIS shape data)	X	X	X	X				
15. DTED	X	X	X					
16. CADRG and CIB	X	X	X					
17. Basic Rastar (JPG,BMP)	X	X	X	X				
18. Comma Separated (CSV)	X	X		X	X			
19. KML (vector and raster in XML format)		X		X	X			
<b>Projections</b>								
20. Orthographic	x <sup>2</sup>	X	X	X	X		X	
21. Equal Arc (LLXY/CADRG)	X	X	X			X		
22. Mercator	x <sup>2</sup>	X	X					
23. Gnostic	x <sup>2</sup>	X	X					
24. Polar Stereographic		X	X					
25. Lambert Conformal Cone	x <sup>2</sup>	X	X					
26. UTM/MGRS		X	X					
<b>General Performance and Dependencies</b>								
27. Speed			X	X	X	X	X	
28. Reliability		X	X	X	X	X	X	
29. Validated Algorithms		X						
30. Internet Independent	X		X				X	X

**Notes:**

- <sup>1</sup> Partial – there is only control of raster imagery; there is no control over poly, line or icon layers. Also, raster imagery always shows up above polys and lines, and always shows up below icons as well as other Google Earth native data like roads. Draw order *is not* dependent on ordering in the folders or the KML.
- <sup>2</sup> Unable to overlay raster imagery in this projection.
- <sup>3</sup> These capabilities are easily codable, but do not come “out-of-the-box.”

### ***OpenMap***

**Pros:** OpenMap is an open source library that can be used either as an API to incorporate into the user's application, or as a fully functional standalone application. Almost every aspect of it is configurable—from the GUI layout and functionality to the data handling of each layer.

**Cons:** OpenMap is limited to 2D mapping capabilities, virtually all information must be provided by the user, and it has observed issues with speed and reliability, specifically when dealing with large amounts of raster data such as DTED or CADRG.

**Licensing:** Open Source; see <http://openmap.bbn.com/license.html>

**Notes:**

- Oddly enough, even though OpenMap has ready made layers for mapping-specific data such as DTED and RPF, there aren't pre-made layers for generic raster and shape layers. These would have to be coded from basic layers.
- The OpenMap Architecture is described here:  
<http://openmap.bbn.com/doc/openmap-arch.html#toc5>

### ***MapObjects – Java Edition and ArcGIS (C/JMTK)***

**Pros:** ArcGIS is a fully mature industry standard mapping kit. It has every feature we may want and more. The C/JMTK version comes with multiple extensions including a Java implementation.

**Cons:** Our interface to ArcGIS would be be MapObjects – Java Edition, which is little more than a basic mapping tool, probably not as powerful as OpenMap. All ArcGIS created data would have to be served to MapObject layers. If we can't get a government sponsor for the C/JMTK version of this, it is most likely out of our price-range.

**Licensing:** *Possibly* free under OEAVT.

**Notes:**

- Capability matrix: <http://www.esri.com/library/brochures/pdfs/arcgis92-functionality-matrix.pdf>
- MapObjects-Java Edition:  
<http://www.esri.com/software/mojava/about/overview.html>

## **OSSIM**

**Pros:** OSSIM is a library that has substantial capability to load all the file types we need and render in all the projection we want.

**Cons:** OSSIM is not a Mapping development toolkit and really has no built in mapping functionality beyond the mention file loading and image rendering. All mapping functionality would have to be implemented in house. In addition, many image manipulation capabilities would have to be internally developed such as the geospatial tiling of the CIB and DTED imagery.

**Licensing:** Open Source

### **Notes:**

- Website: <http://www.ossim.org/OSSIM/Welcome.html>

## **Google Earth (GE)**

**Pros:** Google Earth is a fully functional 3D mapping tool that out-of-the-box supplies quite a lot of data—terrain imagery and elevation, geopolitical data, road networks, and more. It is fast and seems reliable. User supplied data is loaded from a format called KML, which is based on XML and can be easily produced.

**Cons:** Google Earth is first and foremost a standalone viewer of its own data. It is not capable of having its GUI configured nor can it be integrated into a user application. Although it does handle some user supplied data, specifically basic raster data and vector data, it is not currently capable of processing more sophisticated GIS data such as DTED and CADRG. Layering handling is very poor, verging on impossible. Polygonal data, for example is layered arbitrarily depending on what points make up the polygon.

**Licensing:** Basic is free; Pro has a yearly fee of around \$400. This also may fall under the same category as Google Maps in which the free licensing only applies to publicly available apps. There is no dev kit.

### **Notes:**

- Has a COM API that includes remote control of the camera, loading KML data, and retrieving Feature information. (see <http://earth.google.com/comapi/interfacelApplicationGE.html>)
- GE can be imbedded in a Windows App (see <http://interactiveearth.blogspot.com/2007/01/importing-gis-data-into-google-earth.html>)
- GE has an enterprise version that lets you serve your own data (raster, GIS, etc.). Word on the Net has prices ranging from \$20K - \$100K. Here is an overview of the GE Enterprise capabilities: [http://earth.google.com/earth\\_enterprise.html](http://earth.google.com/earth_enterprise.html).

### **Google Maps (GM)**

**Pros:** None.

**Cons:** The GM API has no handling of raster imagery. GM is only available as a thin client.

**Licensing:** Free for public use; private use has associated fees starting at \$10K.

**Notes:**

- The GM API is javascript.
- The API is documented here: <http://www.google.com/apis/maps/documentation/>
- Google Maps can be made to show raster data with SVG plug-ins, but appears to run slow, plus all layer handling would have to be implemented in-house. (<http://www.web-maps.com/GoogleMapExplore/>)
- Here is another discussion about overlaying raster imagery onto a google map. It involves using MapServer (<http://mapserver.gis.umn.edu/>) among other tools: [http://groups.google.com/group/Google-Maps-API/browse\\_thread/thread/1717c535f611a207/838ac2b2a8db4b06?q=wms+nelson&rnum=2#838ac2b2a8db4b06](http://groups.google.com/group/Google-Maps-API/browse_thread/thread/1717c535f611a207/838ac2b2a8db4b06?q=wms+nelson&rnum=2#838ac2b2a8db4b06)

### **JView**

**Pros:** JView is highly optimized and is implemented in Java.

**Cons:** JView is meant as a 3D renderer of imagery onto a spheroid, much like Google Earth. It currently can't easily handle any types of 2d data, such as Polygons and geographic point icons.

**Licensing:** Free to use on OEAVT as GOTS.

**Notes:**

- Website: <https://extranet.rl.af.mil/jview/>

### **uDig**

**Licensing:** Open Source (LGPL)

**Notes:**

- uDig is not really a mapping development kit, but an open-source application developed on the Eclipse Modeling Framework. Although it is extendable, it is not what we're looking for.

## Recommendation & Discussion

Development of the GEV based on OpenMap is recommended, based on the availability of key functions, its existing use with the AOC, specifically within IWPC, and with SAIC's development team's familiarity with the tool. SAIC intends to proceed with initial GEV development on this basis absent other direction. We will be performing risk-mitigation activities (e.g., assessing performance with hundreds of layers, extending the Lambert projection to the southern hemisphere, etc.). Some raster-heavy functions needed by the GEV may be achieved using external packages to pre-process data into more manageable formats.

Why not Google Earth? The ability to depict 2D maps in a low-distortion conformal projection is judged to be an essential element for accurately understanding the disposition of forces and events and rules out Google Earth, or virtually any perspective or orthographic only display for the GEV. The figures below illustrate the issue.

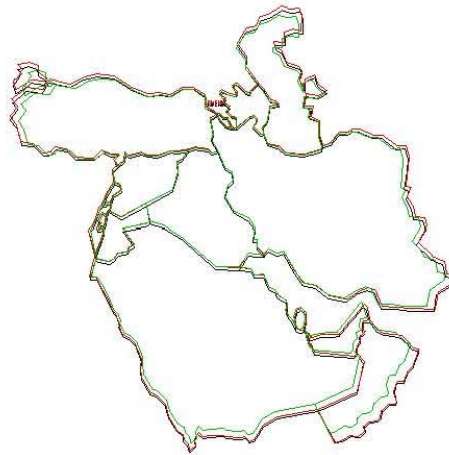

**Figure 1: Small scale distortion comparison: Lambert (black), Azimuthal-Equidistant (red), and Perspective (green).**

For depicting small areas, nearly any common projection is acceptable, as shown in figure 1. Correlation is noted best at the center of the projection (Iraq), with increasing distortion with distance. Note that the perspective projection (Google Earth) is under-representing the distance at the edge of the map. The azimuthal-equidistant has the property of maintaining true scale on all meridians and on the standard parallels. The Lambert projection approximates this, with the added property that great-circle routes are approximately straight lines (thus typical ground points underlying great circle air navigation routes are correctly depicted). Use of NGA standard parallels and the Lambert projection will also result in depictions

essentially identical to paper GNC, JNC JOG and TPC maps and charts familiar to USAF operators.

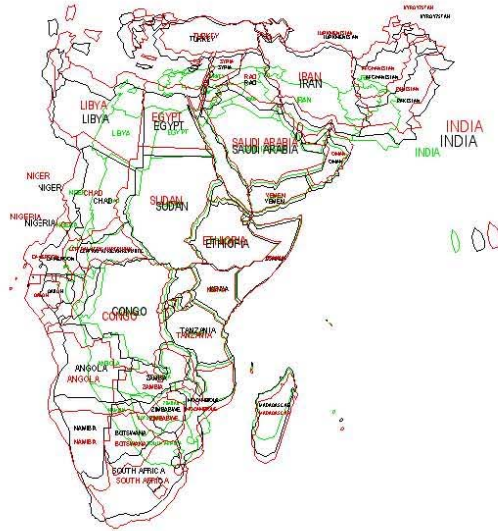

**Figure 1: Large scale distortion comparison: Lambert (black), Azimuthal-Equidistant (red), and Perspective (green).**

Predictably, a larger scale map exhibits greater distortion. This view is centered on Somalia. Note that at the extremes of the map, the perspective projecting under-depicts distances by roughly 15% of the map extent. While useful in 3D rendering, the perspective projection is not conformal and preserves neither true azimuth, area or distance relationships.

Also of concern on both Google Earth and Google Maps are licensing terms, especially for applications not publicly published.

Why not C/JMTK: While the ESRI ArcGIS based C/JMTK is clearly the most capable GIS software considered, it carries significant development risks for the GEV:

- The GEV GUI is intended to be highly optimized for the assessment task, mixing elements of layer control/order with plan hierarchy. Achieving this in C/JMTK appears to be complex, requiring significant coding from scratch.
- The complexity and lack of local experience with the ArcGIS API increases risk.
- The available Java implementation within the C/JMTK does not appear to significantly differ from OpenMap.

# GEV GUI Design Mockups

## Icon Set

The 24 icons used as a base for assessment Symbology

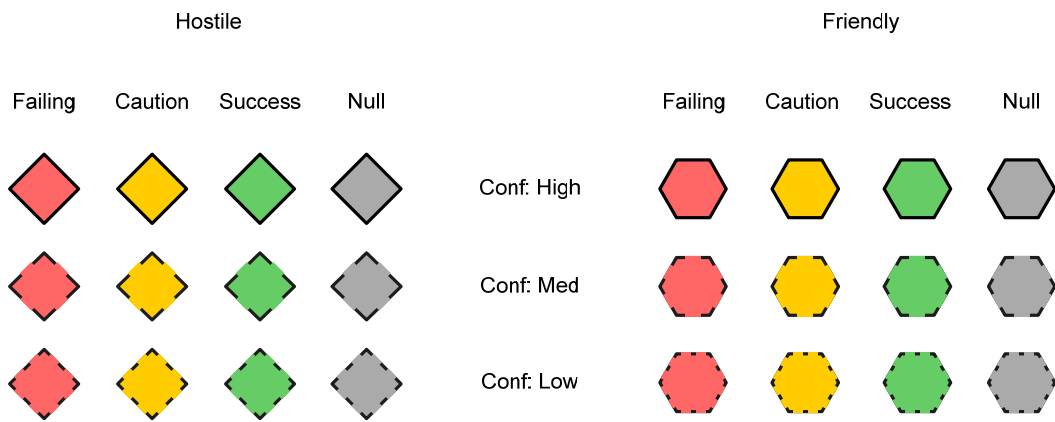

Here are some examples of the weighted status indicators that surround the icons in the GEV.

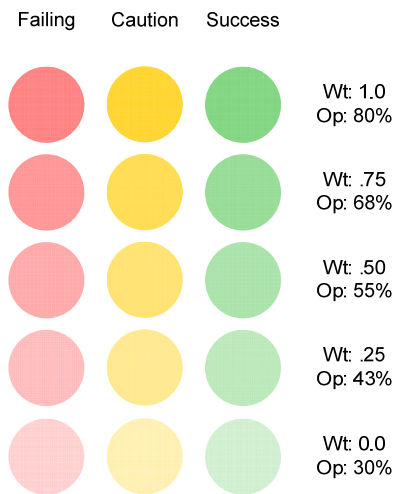

# GEV displaying a TO

The plan element being displayed is shown in the upper left corner in it's GEV assessment format.

All assessment data for the displayed plan element is shown on the GEV. There is a sidebar to the right for non-geospatial assessment data, as well as out of view assessment data.

Assessments with an Area of effect have an unfilled polygon surrounding them. The TO's polygon is a bounding polygon created from aggregating the points and areas of it's children.

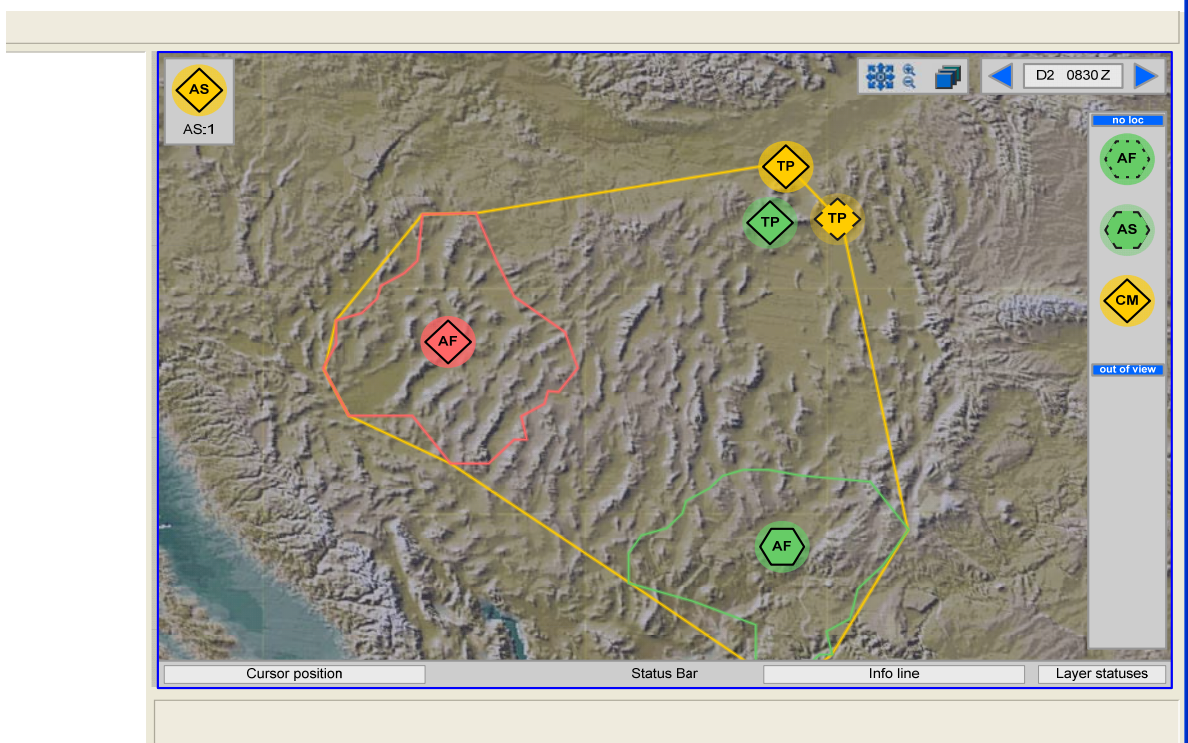

# GEV displaying a TO – partial

The view has been panned upward moving part of the assessment off-screen.

Out of view assessment is displayed along with non-geospatial assessment, in the sidebar.

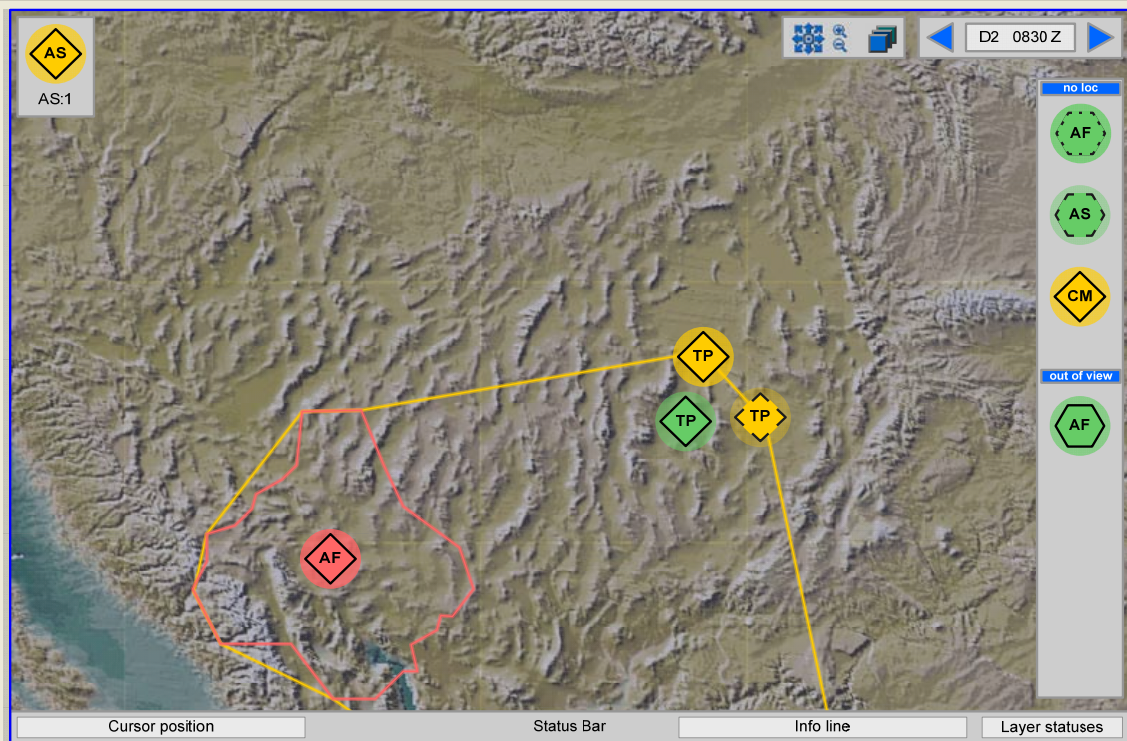

## GEV displaying the expanded TT

A Tactical Task has been expanded. Targets are shown as small dots in the same color as the assessment.

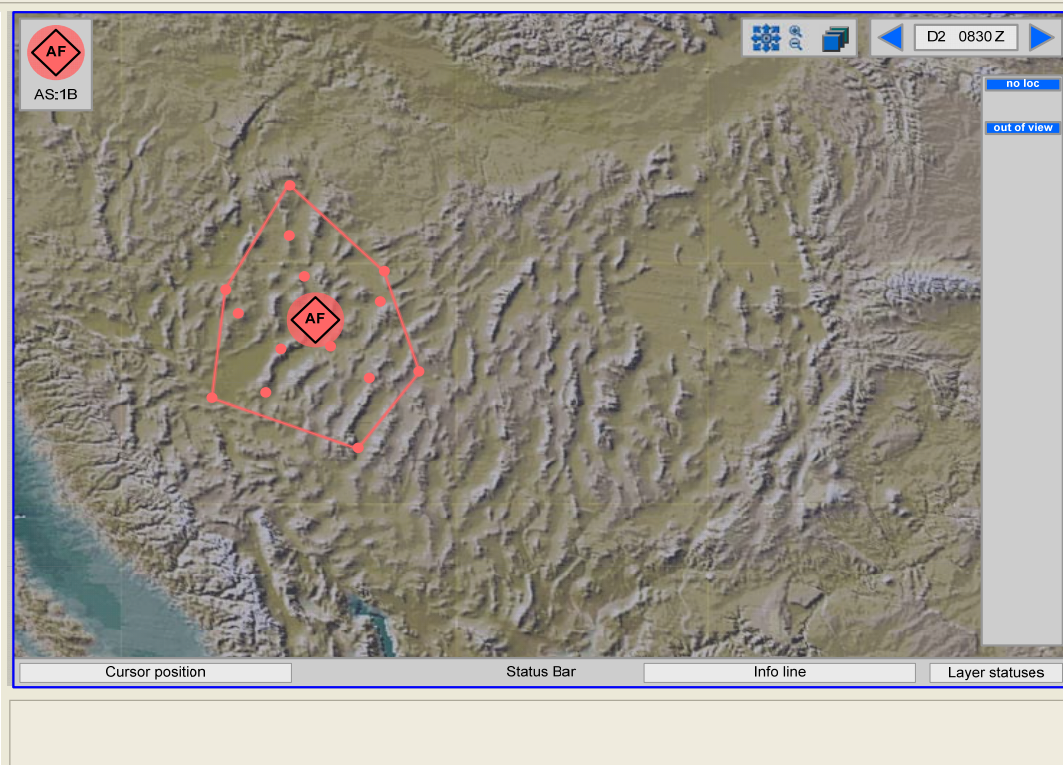

## GEV displaying the collapsed OO

The parent OO of the TO has been collapsed. The TO now has a single representative icon. The TO's assessment data has been simplified to single smaller representative circles. There are two other assessment areas that some of their area can be seen, but not their icon, so they are placed in the out of view sidebar. There is also one non-geospatial assessment data in the sidebar.

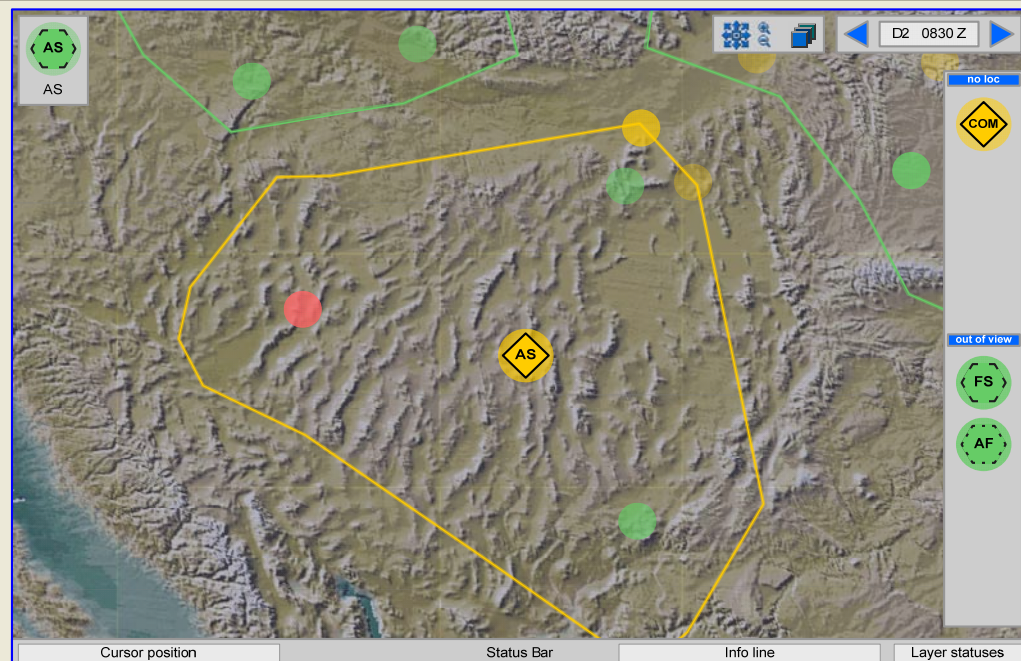

# **APPENDIX E**

## **GEM-S IO ASSESSMENT PROTOTYPE VISUAL SPECIFICATION**

# IO Assessment Prototype Visual Specification

**Edit Indicator**

43 Tac Task 1.1.2 Magnitude Ind 1

Assessed Magnitude: (55,700)

0 0.5 Viral: x2.2

V:126000 < Enter Exact Value

Confidence: low med high

Justification: Attach...

Must input Justification

Cancel Commit changes

**Assessment Explorer**

- Op Objective 1
  - Tactical Task 1.1.1
  - Tactical Task 1.1.2
  - Tactical Task 1.1.3
  - Tactical Task 1.1.4
  - Tactical Task 1.1.5
  - Tactical Task 1.1.6
- Op Objective 2
- Op Objective 3
- Op Objective 4
- Op Objective 5
- Op Objective 6

**Tactical Task 1.1.3**

Reduction of Capability

100% 75% 50% 25% 0%

Days

Duration

Baseline Magnitude: 89,100

**+ Desired Effect**

**Duration Indicators**

- 13 Tac Task 1.1.3 Des Duration Ind 1
- 15 Tac Task 1.1.3 Des Duration Ind 2

**Cap Redux Indicators**

- 22 Tac Task 1.1.3 Des Cap Redux Ind 1
- 28 Tac Task 1.1.3 Des Cap Redux Ind 2
- 17 Tac Task 1.1.3 Des Cap Redux Ind 3
- 23 Tac Task 1.1.3 Des Cap Redux Ind 4

**Collateral Effect**

**Duration Indicators**

- 24 Tac Task 1.1.3 Coll Duration Ind 1
- 27 Tac Task 1.1.3 Coll Duration Ind 2
- 34 Tac Task 1.1.3 Coll Duration Ind 3
- 22 Tac Task 1.1.3 Coll Duration Ind 4

**Cap Redux Indicators**

- 47 Tac Task 1.1.3 Coll Cap Redux Ind 1
- 25 Tac Task 1.1.3 Coll Cap Redux Ind 2

Objective 1.1

Expected Magnitude: 146,900

Direction

Expected Magnitude

**Direction Indicators (1/10)**

- 35 Tac Obj 1.1 Direction Ind 1

**Magnitude Indicators (1/10)**

- 35 Tac Obj 1.1 Magnitude Ind 1
- 20 Tac Obj 1.1 Magnitude Ind 2

**Sub Op Rollups (1/10)**

- 28 Tactical Task 1.1.1
- 8 Tactical Task 1.1.2
- 13 Tactical Task 1.1.3
- 1 Tactical Task 1.1.4
- 6 Tactical Task 1.1.5
- 17 Tactical Task 1.1.6

**Edit Weight Set**

25 Tac Task 1.1.1 Des Duration Ind 1

28 Tac Task 1.1.1 Des Duration Ind 2

47 Tac Task 1.1.1 Des Duration Ind 3

Justification: Attach...

Cancel Commit changes

**Assessment Explorer**

**Task Explorer (Normal View)**

- ▼ The Plan
  - ▼ Op Objective 1
    - ▼ Tac Objective 1.1
      - ▲ Tactical Task 1.1.1
      - ▲ Tactical Task 1.1.2
      - ▲ Tactical Task 1.1.3
      - ▲ Tactical Task 1.1.4
      - ▲ Tactical Task 1.1.5
      - ▲ Tactical Task 1.1.6
    - ▶ Tac Objective 1.2
    - ▶ Tac Objective 1.3
  - ▶ Op Objective 2
  - ▶ Op Objective 3
  - ▶ Op Objective 4
  - ▶ Op Objective 5
  - ▶ Op Objective 6

**Plan Element; Acceptable Assessment**

**Influence Op; Favorable Assessment**

**Active Influence; Unfavorable Assessment**

The icon indicates type.  
The Color indicates spotlight assessment

Clicking on a element will bring up it's detailed assessment graph, indicator list, and Sub Op Rollup list if it has subordinate tasks.

The plan tree nodes can be expanded or closed using the triangles.

Toggles the Explorer between Normal View (the one seen here and the default), and Global View (discussed later).

Expected Magnitude: 146,900 < Edit

Direction Indicators (35%)

35 Tac Obj 1.1 Direction Ind 1

Direction Indicators (35%)

28	Tactical Task 1.1.1
5	Tactical Task 1.1.2
13	Tactical Task 1.1.3
1	Tactical Task 1.1.4
6	Tactical Task 1.1.5
12	Tactical Task 1.1.6

Expected Magnitude

Normal Global

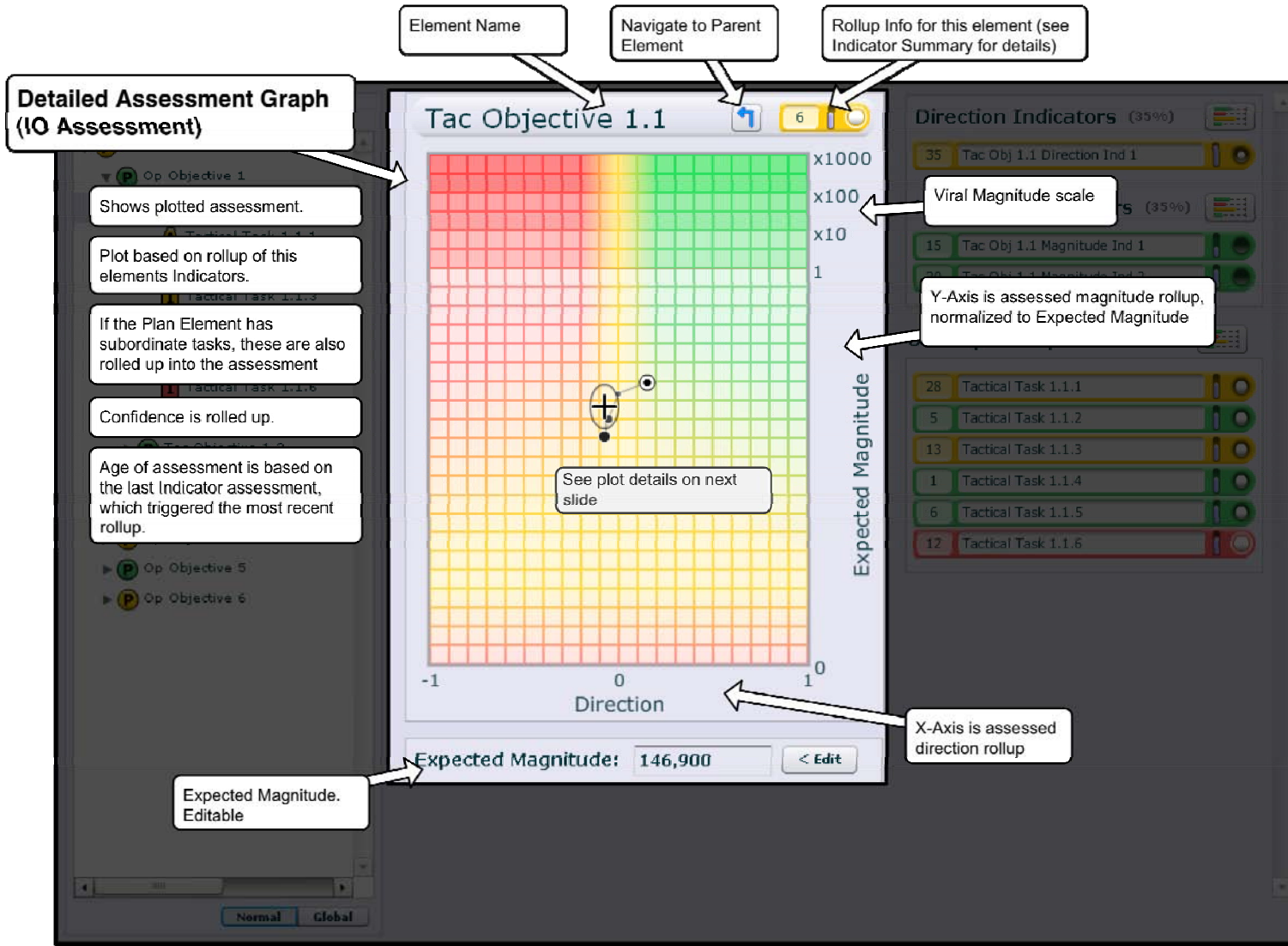

**Detailed Assessment Graph  
(IO Assessment) – Plot Details**

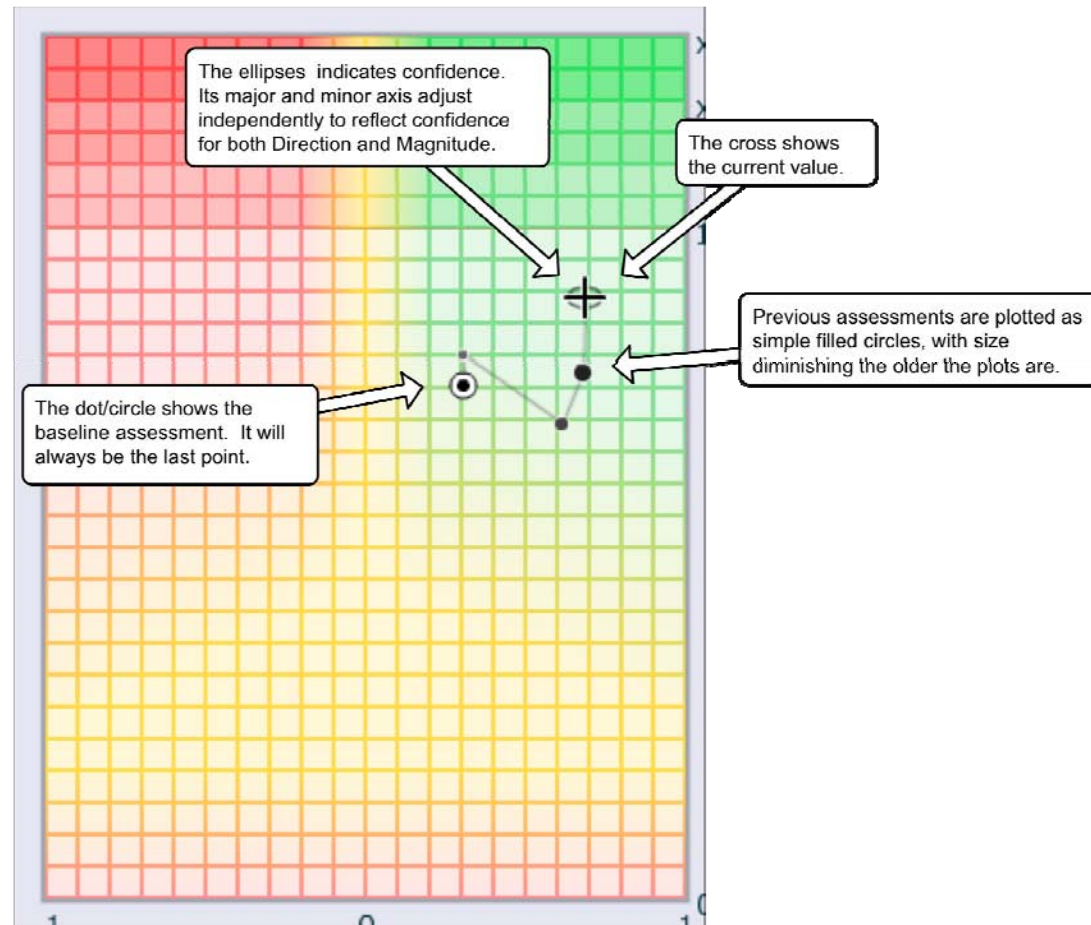

**Detailed Assessment Graph  
(IO Assessment) – Subcomponent Scatter Plot Details**

A scatter plot of all the plan element components that make the rollup is brought up when the user clicks and holds down the left mouse button.

Sub Op Rollups are drawn as crosses at their individual assessed values. Their size reflects their rollup weighting.

Two axis lines are drawn as a reminder of where the "blown up" plan element rollup is located, giving a reference point for the component plots.

Here's the indicator lists and sub rollup list of this "blown up" plan element assessment

Direction Indicators (55%)	
23	Op Obj 5 Direction Ind 1
32	Op Obj 5 Direction Ind 2
Magnitude Indicators (55%)	
3	Op Obj 5 Magnitude Ind 1
52	Op Obj 5 Magnitude Ind 2
Sub Op Rollups (44%)	
6	Tac Objective 5.1
14	Tac Objective 5.2
6	Tac Objective 5.3
0	Tac Objective 5.4
19	Tac Objective 5.5

Direction Indicator Assessments are drawn as tic marks along the Direction Axis at their individual assessed values. Their length reflects their weight.

Magnitude Indicator Assessments are drawn as tic marks along the Magnitude Axis at their individual assessed values. Their length reflects their weight.

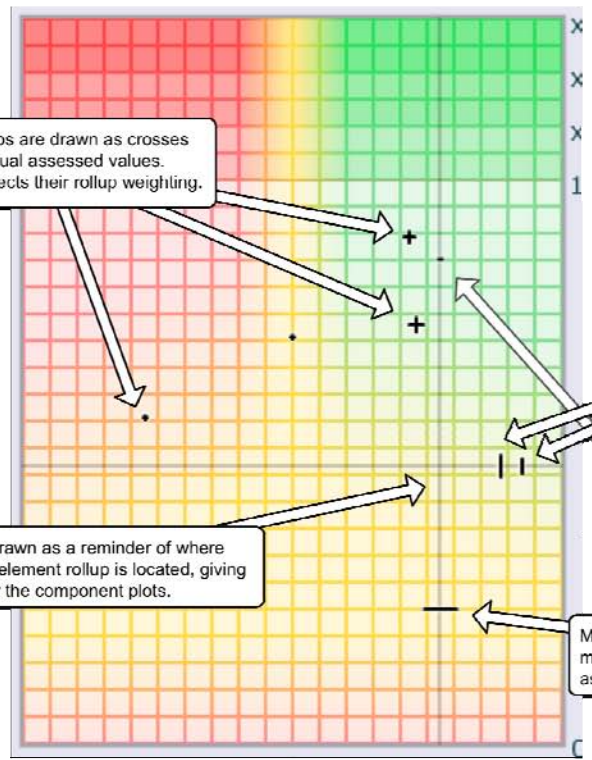

**Assessment Explorer**

**Indicator List (Influence)**

Double Clicking an Indicator will bring up its Editor.

Double Clicking a Sub Op will Navigate to that Ops Detailed Assessment—the same as clicking on the Op in the Explorer.

Direction Indicator List

Magnitude Indicator List

Subordinate Op Rollup List. This is only present if displaying a Plan Element that has Sub Ops

Direction Indicators (35%)

35	Tac Obj 1.1 Direction Ind 1
----	-----------------------------

Magnitude Indicators (35%)

15	Tac Obj 1.1 Magnitude Ind 1
20	Tac Obj 1.1 Magnitude Ind 2

Sub Op Rollups (65%)

28	Tactical Task 1.1.1
5	Tactical Task 1.1.2
13	Tactical Task 1.1.3
1	Tactical Task 1.1.4
6	Tactical Task 1.1.5
12	Tactical Task 1.1.6

Expected Magnitude: 146,900 < Edit

Normal Global

Launches Weight Editor

total % weight for the group. (Only shown when there are Sub Ops)

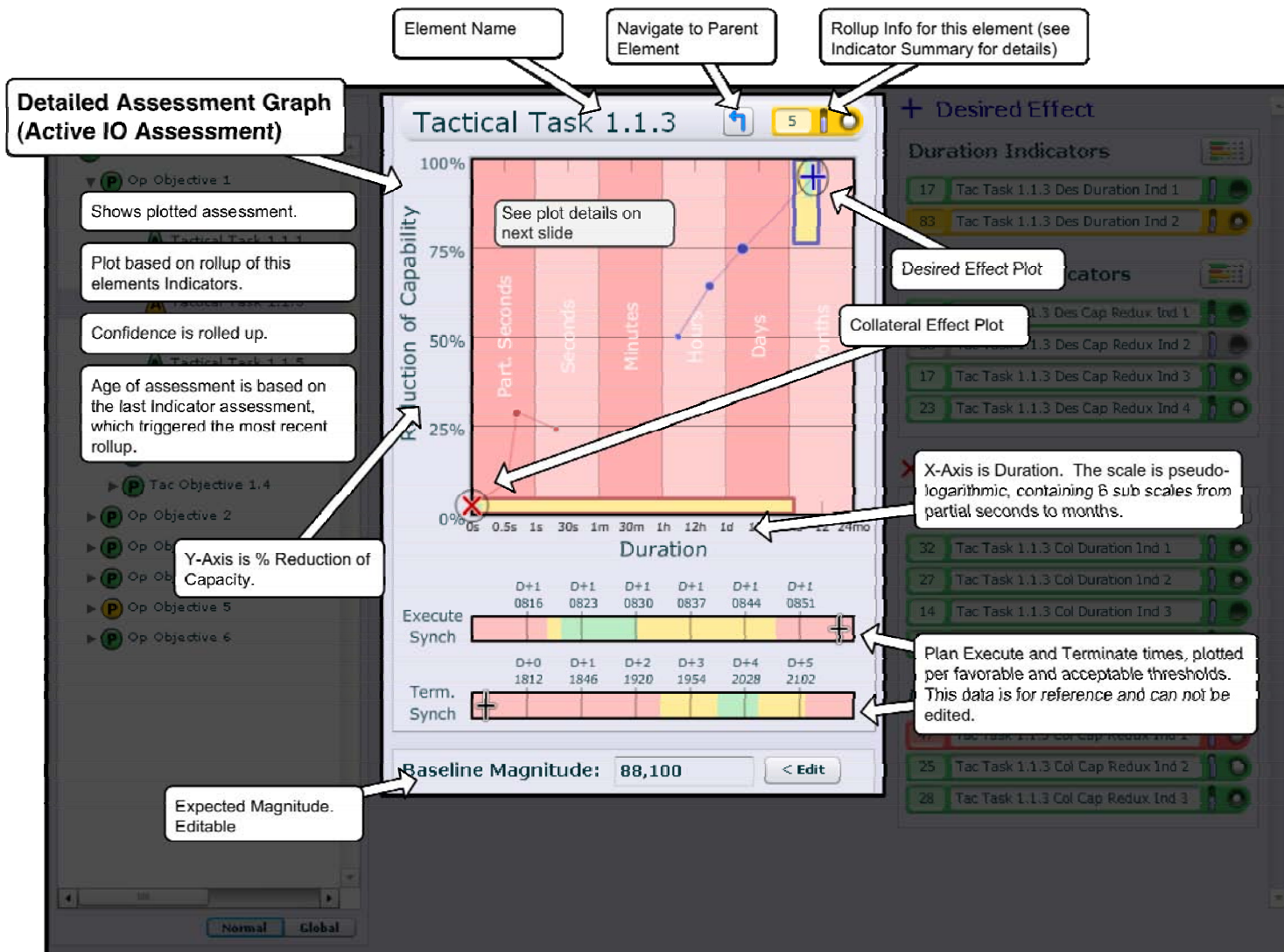

## Detailed Assessment Graph (Active IO Assessment) – Plot Details

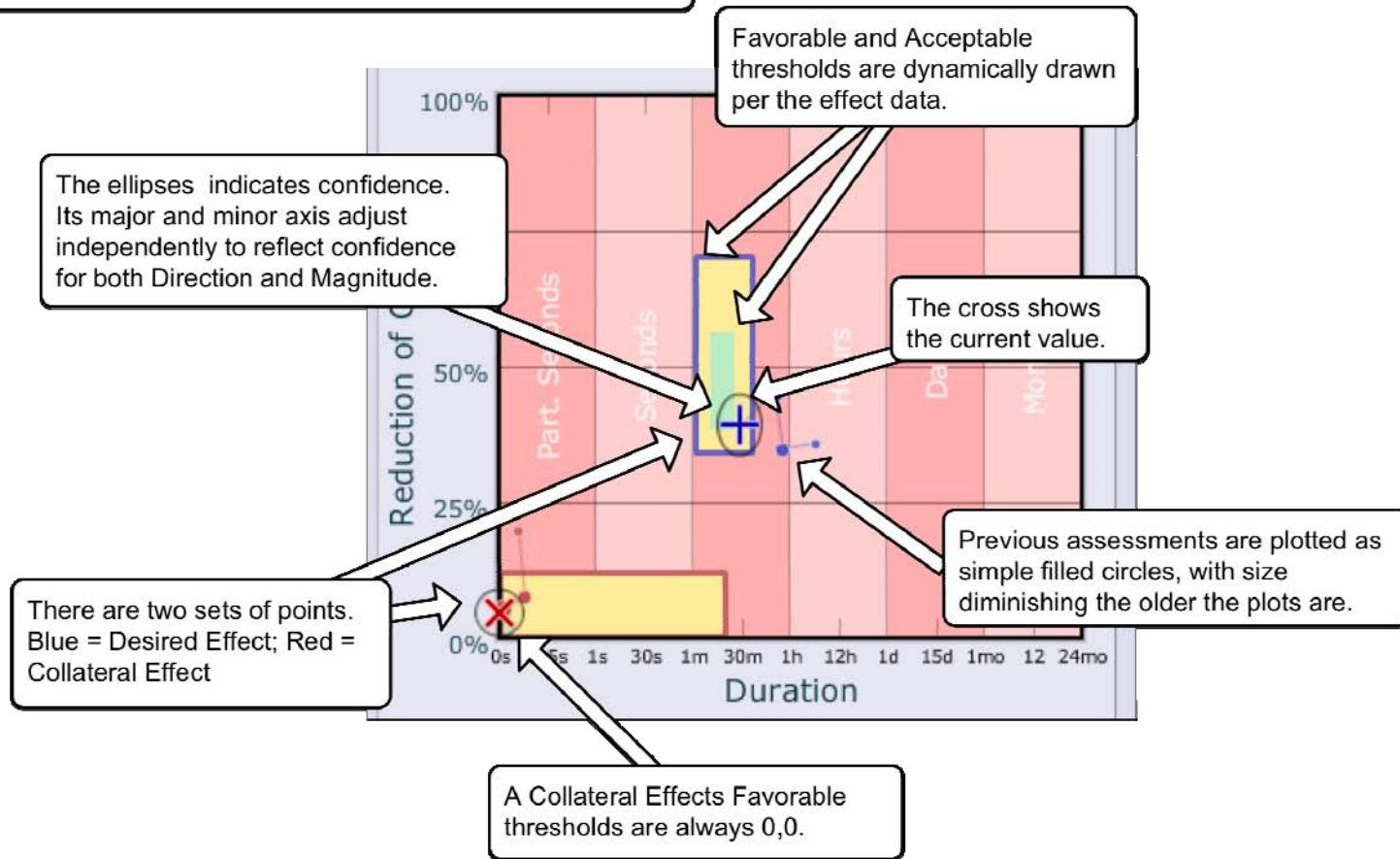

**Assessment Explorer**

**Indicator List (Active Influence)**

Double Clicking an Indicator will bring up its Editor.

Double Clicking a Sub Op will Navigate to that Ops Detailed Assessment—the same as clicking on the Op in the Explorer.

**Desired Effect Duration Indicators**

**Desired Effect Capacity Reduction Indicator List**

**Collateral Effect Duration Indicators**

**Collateral Effect Capacity Reduction Indicator List**

**Desired Effect**

**Duration Indicators**

- 17 Tac Task 1.1.3 Des Duration Ind 1
- 83 Tac Task 1.1.3 Des Duration Ind 2

**Cap Redux Indicators**

- 22 Tac Task 1.1.3 Des Cap Redux Ind 1
- 38 Tac Task 1.1.3 Des Cap Redux Ind 2
- 17 Tac Task 1.1.3 Des Cap Redux Ind 3
- 23 Tac Task 1.1.3 Des Cap Redux Ind 4

**Collateral Effect**

**Duration Indicators**

- 32 Tac Task 1.1.3 Col Duration Ind 1
- 27 Tac Task 1.1.3 Col Duration Ind 2
- 14 Tac Task 1.1.3 Col Duration Ind 3
- 27 Tac Task 1.1.3 Col Duration Ind 4

**Cap Redux Indicators**

- 47 Tac Task 1.1.3 Col Cap Redux Ind 1
- 25 Tac Task 1.1.3 Col Cap Redux Ind 2
- 28 Tac Task 1.1.3 Col Cap Redux Ind 3

Launches Weight Editor

Scroll Bar will activate if indicator list exceed window size.

**Execute Synch**

	D+1	D+1	D+1	D+1	D+1	D+1
0816	0823	0830	0837	0844	0851	

**Term. Synch**

	D+0	D+1	D+2	D+3	D+4	D+5
1812	1846	1920	1954	2028	2102	

Baseline Magnitude: 88,100 < Edit

Normal Global

**Indicator Summary**

**Weight**  
The number represents the % weight. The background saturation also darkens as weight increases

**Name of Indicator or Plan Element**

**Confidence**  
A bar that fills bottom to top as confidence increases

**Age**  
The indicator is all black when beyond the oldest threshold. White increases with newer updates. An indicator updates this session will be all white with a "glow" around it.

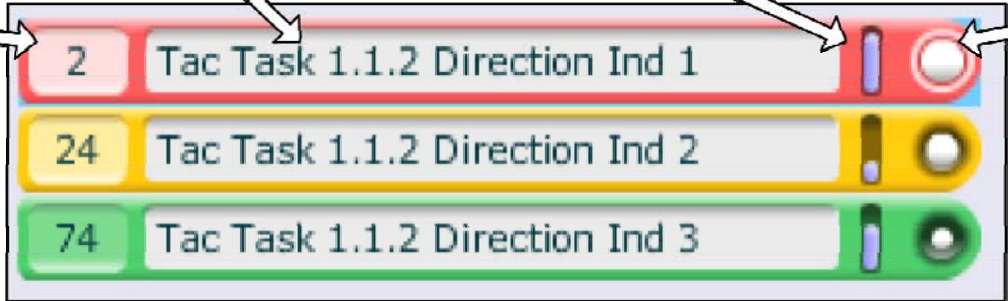

Hovering over the different components brings up a tooltip that gives the exact numerical value of the specific information.  
Hovering over the Name will give the numerical rollup values for that indicator

