



TECHNICAL REPORT AMR-SS-09-04

MISSILELAB USER'S GUIDE

Lamar M. Auman

**System Simulation and Development Directorate
Aviation and Missile Research, Development,
and Engineering Center**

and

Kristina Kirby-Brown

**Dynetics, Inc.
1002 Explorer Boulevard
Huntsville, AL 35806**

February 2009

Approved for public release; distribution is unlimited.

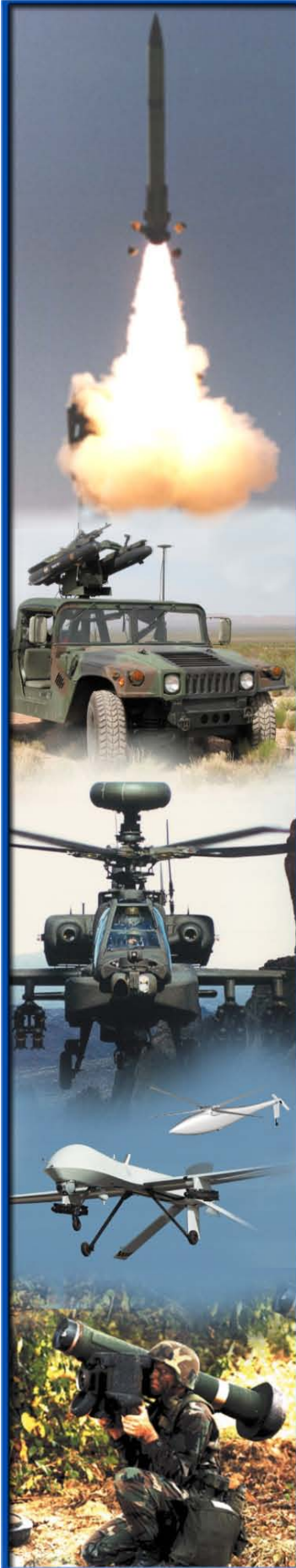

DESTRUCTION NOTICE

FOR CLASSIFIED DOCUMENTS, FOLLOW THE PROCEDURES IN DoD 5200.22-M, INDUSTRIAL SECURITY MANUAL, SECTION II-19 OR DoD 5200.1-R, INFORMATION SECURITY PROGRAM REGULATION, CHAPTER IX. FOR UNCLASSIFIED, LIMITED DOCUMENTS, DESTROY BY ANY METHOD THAT WILL PREVENT DISCLOSURE OF CONTENTS OR RECONSTRUCTION OF THE DOCUMENT.

DISCLAIMER

THE FINDINGS IN THIS REPORT ARE NOT TO BE CONSTRUED AS AN OFFICIAL DEPARTMENT OF THE ARMY POSITION UNLESS SO DESIGNATED BY OTHER AUTHORIZED DOCUMENTS.

TRADE NAMES

USE OF TRADE NAMES OR MANUFACTURERS IN THIS REPORT DOES NOT CONSTITUTE AN OFFICIAL ENDORSEMENT OR APPROVAL OF THE USE OF SUCH COMMERCIAL HARDWARE OR SOFTWARE.

REPORT DOCUMENTATION PAGE			Form Approved OMB No. 074-0188	
Public reporting burden for this collection of information is estimated to average 1 hour per response, including the time for reviewing instructions, searching existing data sources, gathering and maintaining the data needed, and completing and reviewing this collection of information. Send comments regarding this burden estimate or any other aspect of this collection of information, including suggestions for reducing this burden to Washington Headquarters Services, Directorate for Information Operations and Reports, 1215 Jefferson Davis Highway, Suite 1204, Arlington, VA 22202-4302, and to the Office of Management and Budget, Paperwork Reduction Project (0704-0188), Washington, DC 20503				
1. AGENCY USE ONLY	2. REPORT DATE February 2009	3. REPORT TYPE AND DATES COVERED Final		
4. TITLE AND SUBTITLE MissileLab User's Guide			5. FUNDING NUMBERS	
6. AUTHOR(S) Lamar M. Auman, Kristina Kirby-Brown				
7. PERFORMING ORGANIZATION NAME(S) AND ADDRESS(ES) Commander, U.S. Army Research, Development, and Engineering Command ATTN: AMSRD-AMR-SS-AT Redstone Arsenal, AL 35898			8. PERFORMING ORGANIZATION REPORT NUMBER TR-AMR-SS-09-04	
9. SPONSORING / MONITORING AGENCY NAME(S) AND ADDRESS(ES)			10. SPONSORING / MONITORING AGENCY REPORT NUMBER	
11. SUPPLEMENTARY NOTES				
12a. DISTRIBUTION / AVAILABILITY STATEMENT Approved for Public Release; distribution is unlimited.			12b. DISTRIBUTION CODE A	
13. ABSTRACT (<i>Maximum 200 Words</i>) MissileLab is a Microsoft Window based, Graphical User Interface (GUI) written in Visual Basic, that assist the user in running several Missile Aerodynamic Prediction codes. MissileLab allow the aerodynamicist to input one set of geometry and atmospheric conditions and then run several aerodynamic prediction codes with the click of a button. MissileLab creates input files for and executes Missile DATCOM, AeroPrediction Code (AP98, AP02, and AP05), NEAR MISL3, MISDL and HASC. A S/HABP geometry input file can also be created. In addition, MissileLab exports 3D triangulated surface geometry files in several formats.. MissileLab features include a user-friendly GUI, 2-D line sketch, a 3-D solid model display of the missile geometry, customizable help information, and display and plotting of the output files from the prediction codes.				
14. SUBJECT TERMS Aerodynamic Analysis, Aerodynamic Prediction Codes, Missile DATCOM, NSWC AP98, AP02, AP05, NEAR MISL3, NEAR MISDL, HASC, NASA CART3D HASC, S/HABP			15. NUMBER OF PAGES 89	
			16. PRICE CODE	
17. SECURITY CLASSIFICATION OF REPORT UNCLASSIFIED	18. SECURITY CLASSIFICATION OF THIS PAGE UNCLASSIFIED	19. SECURITY CLASSIFICATION OF ABSTRACT UNCLASSIFIED	20. LIMITATION OF ABSTRACT SAR	

NSN 7540-01-280-5500

Standard Form 298 (Rev. 2-89)
Prescribed by ANSI Std. Z39-18
298-102

TABLE OF CONTENTS

	<u>Page</u>
I. INTRODUCTION	1
A. Guiding Philosophy Behind the Creation of MissileLab.....	1
B. MissileLab Configuration Management Philosophy	1
C. Background	1
II. INSTALLING MISSILELAB INTERFACE.....	3
A. MissileLab Installation File	3
B. Copying the AeroEngine Files	3
III. THE MISSILELAB INTERFACE	5
A. Initial MissileLab Set-up.....	5
B. Creating and Opening MissileLab Geometry Files	12
C. Sketching Geometry	16
D. Entering MissileLab Geometry in the GUI.....	19
IV. EXAMPLE CASES	63
A. Project_101.....	63
B. Project_102.....	65
C. Project_103.....	68
V. FREQUENTLY ASKED QUESTIONS (FAQ)	72
REFERENCES	75

LIST OF ILLUSTRATIONS

<u>Figure</u>	<u>Title</u>	<u>Page</u>
1.	Installation Screens.....	4
2.	File Locations for the APEs	5
3.	MissileLab Project Directory Structure	7
4.	Locate Prediction Codes Set-up Screen.....	10
5.	Locate Manuals Set-up Screen	11
6.	Project File Screen.....	12
7.	New Project Screen.....	13
8.	DATCOM Import Screen	14
9.	DATCOM Axibod Option 2 Import Screen.....	15
10.	Open Recent Files Screen.....	16
11.	Sample MissileLab 3-D Sketch.....	17
12.	Sample MissileLab Sketch	18
13.	Sample MissileLab Sketch via Meta File.....	18
14.	Sample MissileLab Fin Sketch	19
15.	Units and Case Identification (ID) Screen.....	20
16.	Supported Text Box Equation Functions	23
17.	Body Geometry Screen.....	25
18.	User-Defined Body Input Screen.....	27
19.	User-Defined Body Points Screen	28
20.	Fin Geometry Screen.....	29
21.	Definitions of WAFs	30
22.	Equivalent Fin Panel Geometry Screen.....	32
23.	Protuberance Geometry Input Screen.....	33

LIST OF ILLUSTRATIONS (CONTINUED)

<u>Figure</u>	<u>Title</u>	<u>Page</u>
24.	Protuberance Type Selection Screen	34
25.	Protuberance Orientation Screen	34
26.	Inlet Geometry Input Screen	35
27.	Reference Screen.....	36
28.	Roughness Height Selection Screen	37
29.	Roughness Height Ratio Selection Screen	38
30.	Geometry Parametrics Screen.....	39
31.	Flight Conditions Input Screen	41
32.	Control Deflections Input screen.....	43
33.	Power-on/Power-off Base Drag Input Screen	43
34.	Inlet Additive Drag Input Screen.....	44
35.	DATCOM Prediction Methods Screen.....	45
36.	DATCOM Output Options Screen.....	45
37.	DATCOM Common Block Output Screen	46
38.	APxx Run-Time Conditions Screen	47
39.	AP-05 Protuberance Input Screen	47
40.	NEAR MISL3 Run-Time Input Screen	48
41.	NEAR MISL3 Body Loads Input Screen	49
42.	HASC Run-Time Input Screen	49
43.	MISDL Fin Parameters Input Screen	50
44.	MISDL Run-Time Input Screen	51
45.	Multiple Run Case Manager Screen.....	52
46.	AeroLab Database Management Screen	53

LIST OF ILLUSTRATIONS (CONCLUDED)

<u>Figure</u>	<u>Title</u>	<u>Page</u>
47.	DATCOM Warning Screen	54
48.	AP Warning Screen	54
49.	NEAR MISL3 Warning Screen.....	55
50.	HASC Warning Screen	55
51.	MISDL Warning Screen	56
52.	List of Error and Warning Checks.....	56
53.	Export Data Screen.....	57
54.	Export 3-D Geometric Model Screen.....	60
55.	Quick-Look Plots Screen.....	61
56.	View Data Screen.....	62
57.	Mass Properties Estimator Tool.....	63
58.	Project 101 Configuration.....	63
59.	Project 102 Configuration.....	65
60.	Project 102 Alternate Wing+Tail Modeling Approach.....	67
61.	Project 103 Configuration Line Sketch	68
62.	Project 103 Configuration 3-D Sketch.....	69
63.	Project 103 Equivalent Wing Sketch	70
64.	Project 103 Equivalent Wing Sketch	71

LIST OF TABLES

<u>Table</u>	<u>Title</u>	<u>Page</u>
1.	Recommended Directory Structure for the APEs	6
2.	MissileLab Project Files and Locations.....	8
3.	Menu Options Panel	21
4.	Body Screen Pull-Down Fields	26
5.	Flight Conditions Screen Pull-Down Fields	41
6.	MISL3 Command Prompt Inputs via the Temp.txt File	58
7.	Project 101 Reference Geometry.....	64
8.	Project 101 Body Geometry	64
9.	Project 101 Canard Geometry.....	64
10.	Project 101 Fin Geometry	64
11.	Project 102 Reference Geometry.....	65
12.	Project 102 Body Geometry	65
13.	Project 102 Canard Geometry.....	66
14.	Project 102 Wing Geometry	66
15.	Project 102 Tail Geometry	67
16.	Project 102 Alternate Wing+Tail Geometry Modeling Approach.....	68
17.	Project 103 Reference Geometry.....	69
18.	Project 103 Body Geometry	69
19.	Project 103 Wing Geometry	70
20.	Project 103 Tail Geometry	71

I. INTRODUCTION

A. Guiding Philosophy Behind the Creation of MissileLab

- Fast, engineering-level, aerodynamic design codes are required in the early stages of missile design projects to perform numerous aerodynamic trade studies.
- It is highly desirable to use several techniques to predict the external aerodynamics, as this gives higher confidence in the results (or points to weaknesses in the various methods).
- The MissileLab interface will map all common airframe geometry inputs to the respective Aerodynamic Prediction Engines (APEs). APE specific inputs will be called out for the given code.
- MissileLab will attempt to identify and warn the user of common input errors.
- MissileLab will communicate with the various APEs via their standard, documented input and output files, and will read pre-existing DATCOM namelist input files.
- MissileLab will feature various graphic displays of the missile geometry to aid the user in verifying configuration input geometry data.
- MissileLab will export triangulated surface geometry in several formats.
- MissileLab will provide quick-look plots of the aerodynamic data generated by most of the APEs.
- The user is responsible for obtaining licensed copies of the various APEs that one wishes to use.
- Tools are needed to assist the engineer in analyzing the data in a timely fashion.

B. MissileLab Configuration Management Philosophy

A given MissileLab project will consist of multiple configuration files (given a “.MLN” file extension) that contain the airframe geometry specific to a single configuration.

Results from a MissileLab run will be stored in a directory corresponding to the configuration file name. This directory may be deleted with no impact to MissileLab. When MissileLab is run, the results directory will be (re)created and contain all APE results and associated input files.

C. Background

In the early stages of missile system design, it is necessary to have the means to quickly and accurately estimate the aerodynamics of a wide variety of missile configuration designs operating over many different flight regimes. The ultimate shape and aerodynamic performance of a missile are highly dependent on mission requirements (range, maneuverability, weight, radar cross-section) and subsystems (payload, propulsion, control actuation system, launch mechanism). Therefore, the applied aerodynamicist must be capable of reliably predicting aerodynamic trends on a wide variety of configurations in a timely manner.

Engineering-level codes provide an immediate means to determine the aerodynamic characteristics of a flight vehicle configuration. The foundations of these codes are extensive databases of experimental tests performed by National Aeronautics and Space Administration (NASA), Army, Air Force, and Navy. A combination of mathematical expressions and table lookups define the semi-empirical nature of these APEs.

For missile applications, the most frequently used semi-empirical codes are Missile DATCOM¹, AeroPrediction code (version AP98^[2,3], AP02^[4,5], AP05^[6,7], AP09^[8]), Nielsen Engineering and Research (NEAR) MISL3^[9], and NEAR MISDL^[10]. Unfortunately, these codes require significantly different input decks; therefore, the applied aerodynamicist must work through the tedious process of setting up input files for the different codes. This process also introduces the potential for error, thereby slowing the aerodynamicist's ability to quickly and reliably provide results to the design team.

It is advisable to run multiple APEs during the design trade process to increase the confidence level associated with the results. However, with ever increasing demands to shorten program development timelines, the aerodynamicist must sometimes choose between conducting additional analysis and meeting schedule demands. The entire design team must find ways to increase the efficiency and accuracy of the initial configuration trade study phase.

To meet the aerodynamicist's needs, a tool dubbed MissileLab has been developed to allow the aerodynamicist to input one set of geometry and atmospheric conditions and then run several missile APEs with the click of a button. MissileLab creates input files for and executes Missile DATCOM, AeroPrediction Code (AP98, AP02, and AP05), NEAR MISL3, MISDL and HASC^[11]. A S/HABP^[12] geometry input file can also be created. In addition, MissileLab exports Three-Dimensional (3-D) triangulated surface geometry files in several formats. MissileLab features include a user-friendly Graphical User Interface (GUI), Two-Dimensional (2-D) line sketch, a 3-D solid model display of the missile geometry, customizable help information, and display and plotting of the output files from the prediction codes.

II. INSTALLING MISSILELAB INTERFACE

MissileLab is a Microsoft Windows based, GUI written in Visual Basic, which assists the user in running several Missile Aerodynamic Prediction codes. As such, in addition to the executables, Windows requires that several “OCX” and “DLL” files be registered on your computer. The MissileLab installation file automatically registers the files.

A. MissileLab Installation File

To install the MissileLab GUI, locate and run the setup file named “Setup_MissileLab_x_yy.exe” (note “x_yy” indicates the MissileLab version that will be installed). Figure 1 presents the various set-up screens that will be encountered.

As MissileLab stores all project files below the point where it is installed, it is **RECOMMENDED**, that MissileLab be installed in the user’s home directory. This is not required, and as seen in Figure 1.b it is not the default location. More on file locations will be discussed later.

Once MissileLab is installed, the user must copy the “AeroEngines” files that are discussed in Section II.B.

B. Copying the AeroEngine Files

After installation, the subdirectories in the “AeroEngine” directory contain contact information on how to obtain valid licenses for the various APEs, and other stand-alone executables that MissileLab will need to have full functionality. Figure 2 presents an example of what the AeroEngines directory might look like.

While the various APEs may be located anywhere on the user’s computer, it is **RECOMMENDED** that the APEs that MissileLab will utilize be located in a directory under the AeroEngines directory. The rationale for this is that when the user “exports” the geometry,

1. MissileLab deletes previous APE specific input and output files,
2. MissileLab then creates the APE specific input files in the directory where the user has indicated the APE exists,
3. MissileLab then runs the APE,
4. MissileLab then copies and renames the output files into the appropriate MissileLab directory.

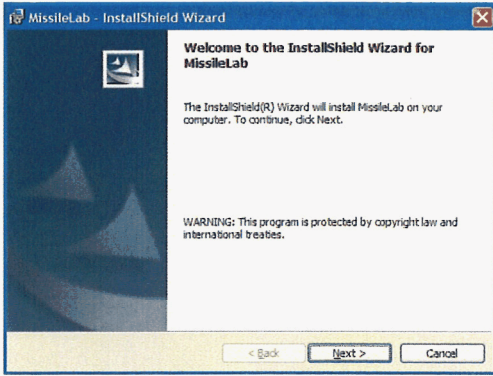

(a)

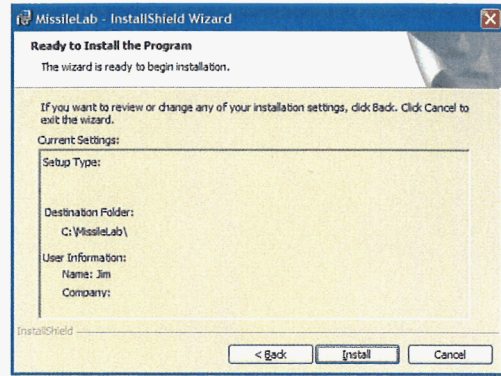

(d)

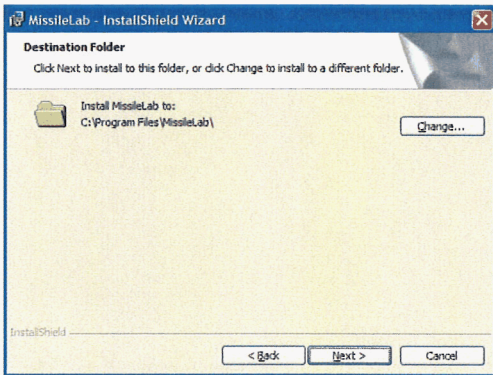

(b)

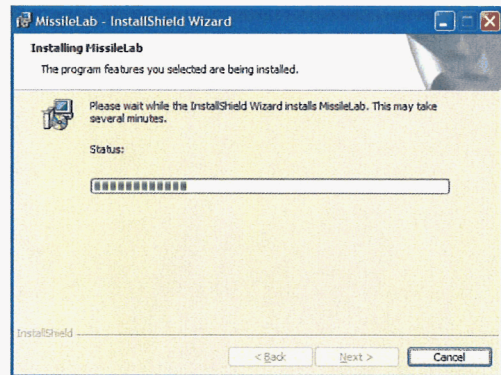

(e)

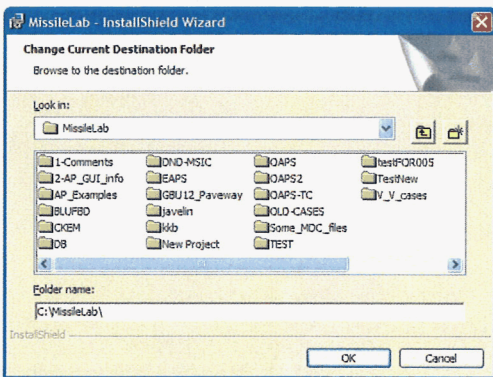

(c)

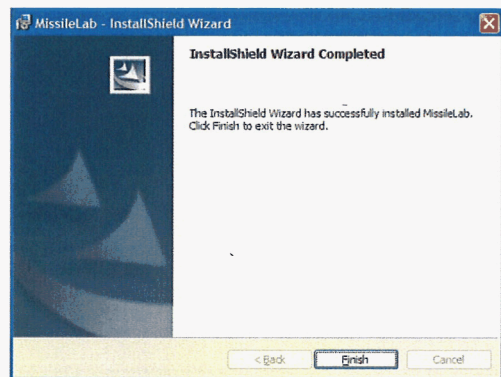

(f)

Figure 1. Installation Screens

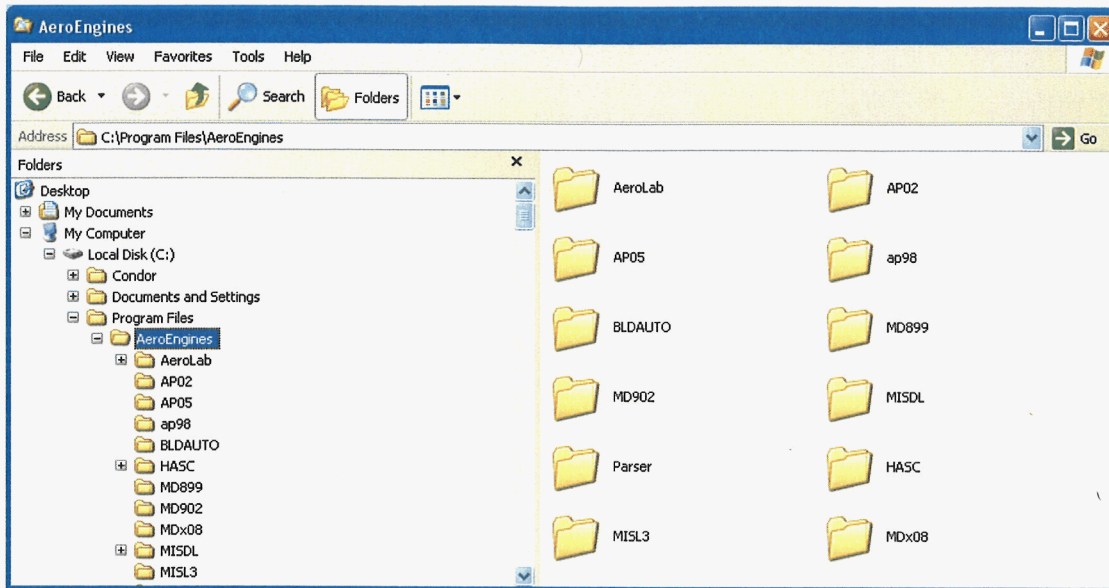

Figure 2. File Locations for the APEs

III. THE MISSILELAB INTERFACE

MissileLab is a Windows based Visual Basic GUI. A series of screens, loosely based on the Missile DATCOM input format, provide the user the ability to define the missile geometry, flight conditions, and reference conditions in a straightforward manner. MissileLab will process these inputs to create the input decks for *Missile DATCOM*, any of the *APxx* codes, *MISL3*, *MISDL* and/or *HASC*. If the user has licensed copies of these and has defined the paths to these APEs in MissileLab, then MissileLab will execute the available APEs. It is noted however, that it is up to the user to acquire the APE licenses from the appropriate vendor, and use of MissileLab does not constitute an agreement with the APE vendors.

A. Initial MissileLab Set-up

When MissileLab is started for the first time following installation, the user must tell MissileLab where the APEs reside on the computer. Before we describe this process, let's first discuss the MissileLab Directory Structure.

1. MissileLab Recommended Directory Structure

While the APEs and other stand-alone programs that MissileLab supports may be located anywhere on your computer, it is **RECOMMENDED** that they be located together as shown previously in Figure 2. Each of the sub-directories under **\AeroEngines** contains the respective executable. The MissileLab installation will create these directories and install an informational file that has contact information for each APE. Table 1 lists the recommended directory structure and required executable that MissileLab will need.

Table 1. Recommended Directory Structure for the APEs

Directory	Executable	Description	Contact
/AeroEngines/MD899 /AeroEngines/MD902 /AeroEngines/MDx08 /AeroEngines/HASC	MDATCOM.EXE HASC.EXE	Missile DATCOM APE High Alpha Stability and Control Panel Code	Mr. William Blake AFRL/VACA 2210 Eighth St. Suite 21 Bldg 146, Area B Wright-Patterson AFB, OH 45433-7531
/AeroEngines/AP09 /AeroEngines/AP05 /AeroEngines/AP02 /AeroEngines/AP98	AP09FOR.EXE AP05FOR.EXE AP02FOR.EXE AP98FOR.EXE	AP09 APE (Latest Version) AP05 APE (no longer distributed) AP02 APE (no longer distributed) AP98 APE (no longer distributed)	Dr. Frank Moore 9449 Grover Drive, Suite 201 King George, VA 22485
/AeroEngines/MISL3 /AeroEngines/M3FLR /AeroEngines/MISDL	MISL3.EXE M3FLR.EXE MISDL.EXE	MISL3 APE (Latest Version) M3FLR APE (no longer supported by NEAR) NEAR Missile Distributed Load Code	Nielsen Engineering & Research Attn: Daniel J. Lesieutre 2700 Augustine Drive, Suite 200 Santa Clara, CA 95054
/AeroEngines/APparse	APPARSE.EXE	Python script that reformats the standard APxx generated 'TAPE6' output file. (installed with MissileLab)	US Army AMRDEC Attn: Mr. Lamar M. Auman AMSRD-AMR-SS-AT Bldg 5400, E339 Redstone Arsenal, AL 35898-5252

The MissileLab project files and associated predicted results are organized according to the “Project” and the “Configuration” as illustrated in Figure 3 and Table 2. Table 2 lists the most common output files of each APE, not all output files.

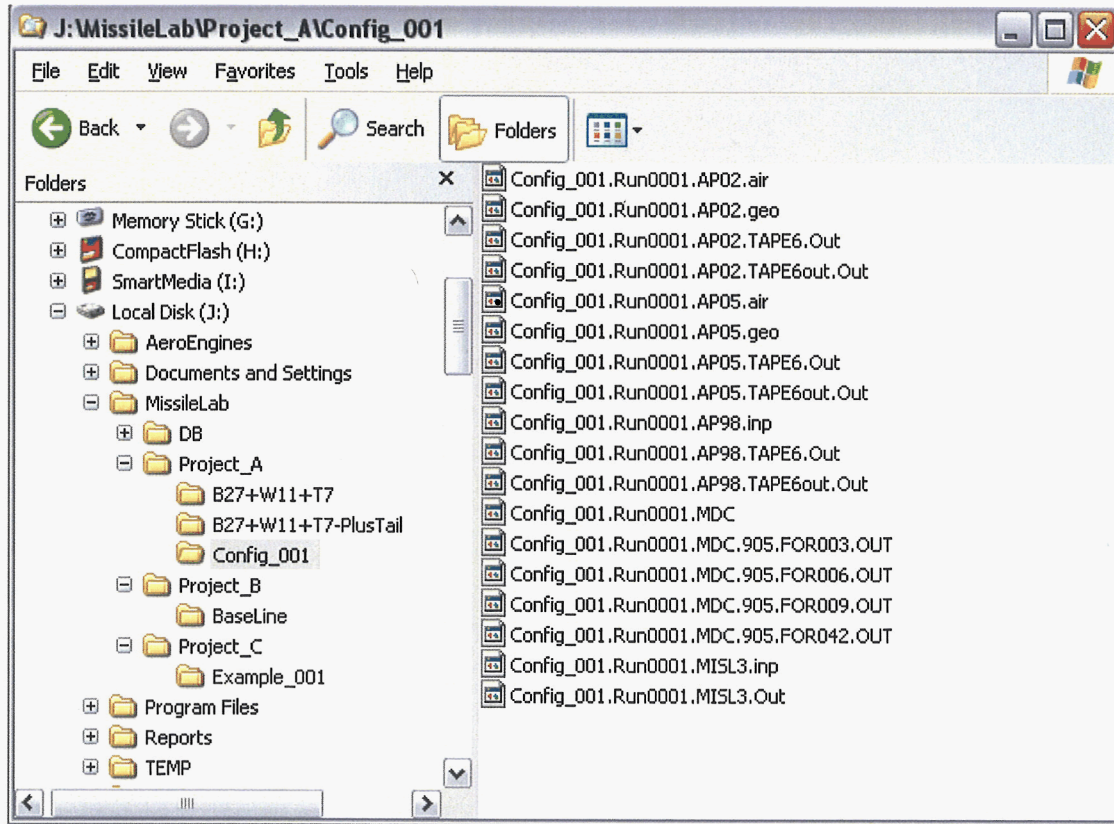

Figure 3. MissileLab Project Directory Structure

Table 2. MissileLab Project Files and Locations

Directory	Files	Description
/MissileLab	MissileLab_Vxxx.EXE MissileLab.INI	MissileLab Executable MissileLab Initialization File
/MissileLab/Project_A	Config_001.MLN Config_002.MLN Config_003.MLN : Config_00x.MLN	MissileLab Configuration Files for "Project_A" (Where "Project_A" and "Config_00x" are defined by the user.)
/MissileLab/Project_A/Config_001_Models	Config_001.geo Config_001.stl Config_001.tri Config_001.pfgd Config_001.txt	S/HABP Geometry File Standard Tessellation Language File CART3D "Tri" File Plot3D File Coordinates File
MissileLab/Project_A/Config_001	Generated by MissileLab	
	DATCOM	Config_001.Run0001.MDC Missile DATCOM input file
	APxx	Config_001.Run0001.AP05.AIR Config_001.Run0001.AP05.GEOM Config_001.Run0001.AP02.AIR Config_001.Run0001.AP02.GEOM Config_001.Run0001.AP98.INP AP05 "AIR" Input file AP05 "GEOM" Input file AP02 "AIR" Input file AP02 "GEOM" Input file AP98 input file
	MISL3	Config_001.Run0001.MISL3.INP MISL3 input file
	MISDL	Config_001.Run001.MISDL.inp Config_001.Run001.MISDL.29 Config_001.Run001.MISDL.50 MISDL Input File MISDL Flight Conditions File MISDL Airfoil Cross-section Data
	HASC	Config_001.Run001.HASC.inp HASC Input File
MissileLab/Project_A/Config_001	Generated by APE and Renamed by MissileLab (Major Files Listed Only)	
	DATCOM	Config_001.Run0001.MDC.FOR006.OUT Config_001.Run0001.MDC.FOR042.CSV Standard DATCOM Output File Output File in Column-Format
	APxx	Config_001.Run001.APxx.TAPE6.OUT Config_001.Run001.APxx.TAPE6out.OUT Config_001.Run001.APxx.TAPE6ou2.CSV Standard APxx Output File APparser "re-formatted" APxx Output File 1 APparser Output File in Column-Format
	MISL3	Config_001.Run001.MISL3.OUT Config_001.Run001.MISL3.ldr.CSV Standard NEAR MISL3 Output File Output File in Column-Format
	MISDL	Config_001.Run001.MISDL.OUT Config_001.Run001.MISDL.CSV Standard MISDL Output File Output file in Column-Format
	HASC	Config_001.Run001.HASC.OUT Standard HASC Output File

2. Locating Executables and Manuals

When MissileLab is run for the first time, the “Locate Prediction Codes” window, illustrated in Figure 4, will appear automatically. The user can also open this window at any time by selecting “[Locate Prediction Codes](#)” under the “[Setup](#)” menu bar. By clicking on the “[Browse](#)” button on this screen, the user can navigate through the computer directory structure to locate the respective APEs. After the APE is located, the user then defines which APE he has selected in step 2 and assigns a version number. For APxx and MISL3, the version number is part of the “Define Program Type” pull-down and will determine what type of input file is written, as well as be used to name the output files. Currently, input files for both HASC and MISDL are not version-specific, and version numbers are not listed for those codes. Finally, the user must click the “[Add](#)” button in step 4.

If the various APE executables are NOT located, MissileLab will still create the input files for all codes but it will not be able to execute the codes.

After all APEs are defined, the user may also locate the stand-alone programs APPARSE, BLDAUTO, and AeroLab.

Once all desired APEs are located, the APE executables will appear on the “[Export Data](#)” screen.

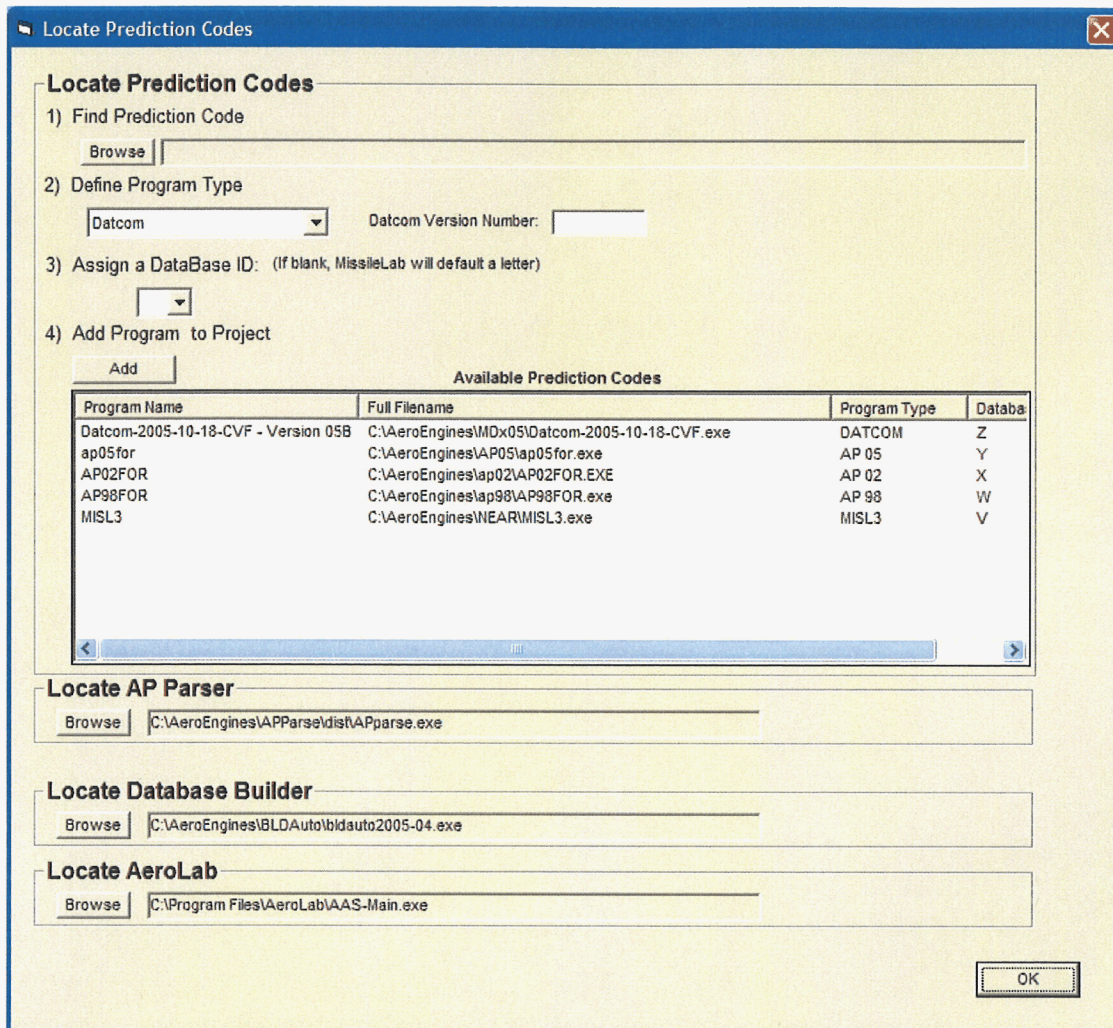

Figure 4. Locate Prediction Codes Set-up Screen

Figure 5 presents the “Locate Manuals / Set Options” set-up screen, which may be used to locate any number of Adobe PDF manuals (or any text document) that the user may want to easily access while using MissileLab. This page is available by selecting “Locate Manuals / Set Options” under the “Setup” menu. Once all the desired manuals are located, they will appear under “Help” in the MissileLab menu bar.

Manuals defined on this screen are available whenever MissileLab is open. As will be discussed later, the user may also locate manuals that are available for the specific configuration file that is currently loaded. These Adobe PDF manuals/documents are defined under the “Input Units” screen discussed in Section III.C.1.

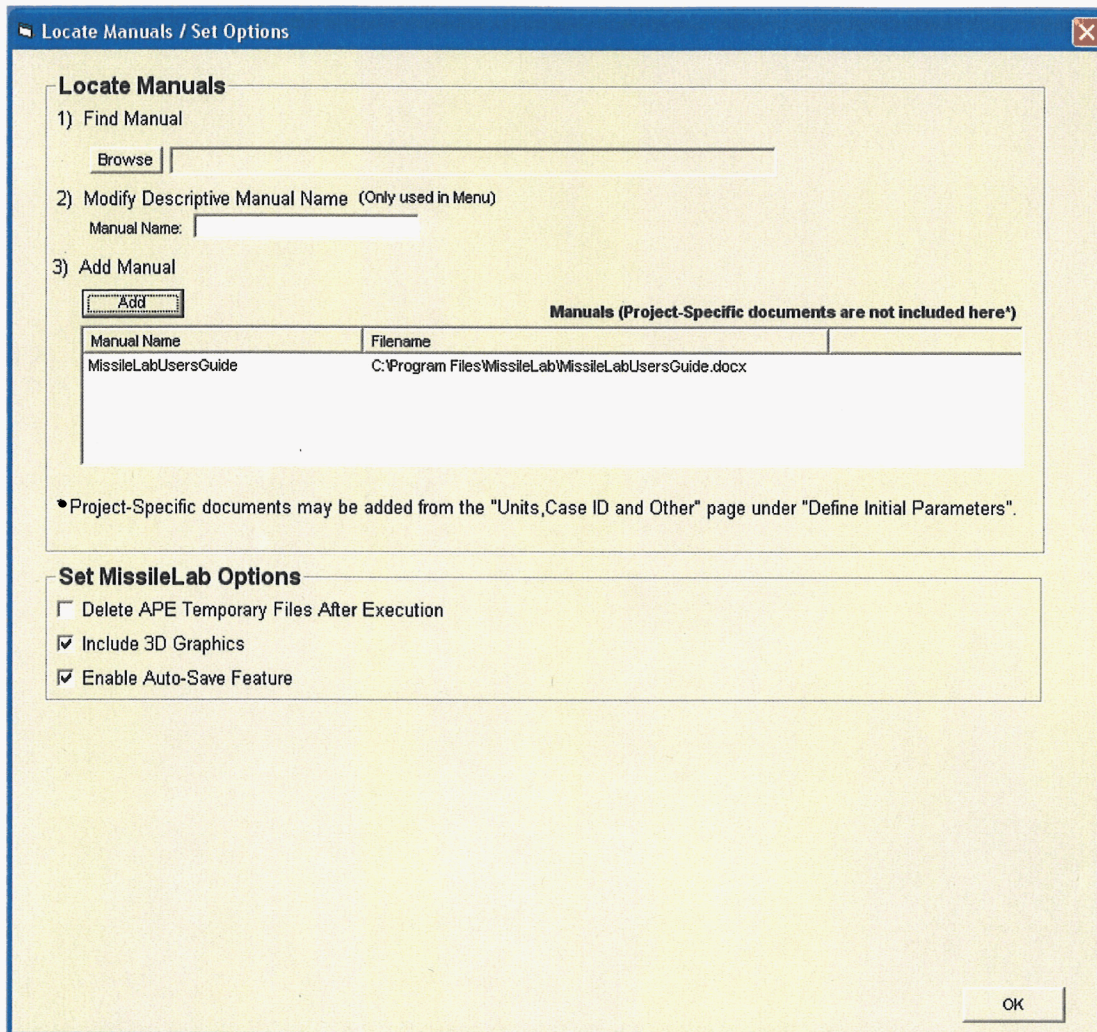

Figure 5. Locate Manuals Set-up Screen

This screen also provides some general user options. The “Delete APE Temporary Files After Execution” option is used to determine whether input/output files in the APE directory are deleted after the APE is executed. These files are renamed and copied to the configuration directory before they are deleted from the APE directory. If the user prefers to not have access to the 3-D sketches, the “Include 3-D Graphics” option can be deselected. This also denies access to the “Export 3D Models” page. MissileLab contains an auto-save feature that will save the entire project in a temp file every time the user switches forms. If MissileLab is not closed properly, the next time it is started the user will be prompted to open this temp file. Checking the “Enable Auto-Save Feature” checkbox will enable this option.

When the user clicks on the “OK” button on either screen, MissileLab will query whether or not to store the set-up information in the file named “MissileLab.ini”. This is the MissileLab initialization file and is located in the same directory as the MissileLab executable. After this file is created, it will be loaded when MissileLab is started and the “Locate Prediction Codes” window will no longer automatically appear. The initialization file is an ASCII text file and while not recommended, the file may be edited by the user with an ASCII text editor.

B. Creating and Opening MissileLab Geometry Files

Figure 6 presents the initial project definition screen. As seen in this figure, there are four tabs (or options) for the user to choose. These options are: (1) start a “New Project”, (2) open an “Existing Project”, (3) “Import (an existing) DATCOM File”, or (4) open a “Recent(ly)” used file. As discussed in Section III.A.1, MissileLab will create a project directory under the MissileLab home directory, and then a configuration results directory under the project directory. As seen in Figure 6, the project directory may have several configuration files (*.MLN) and their corresponding configuration results directories.

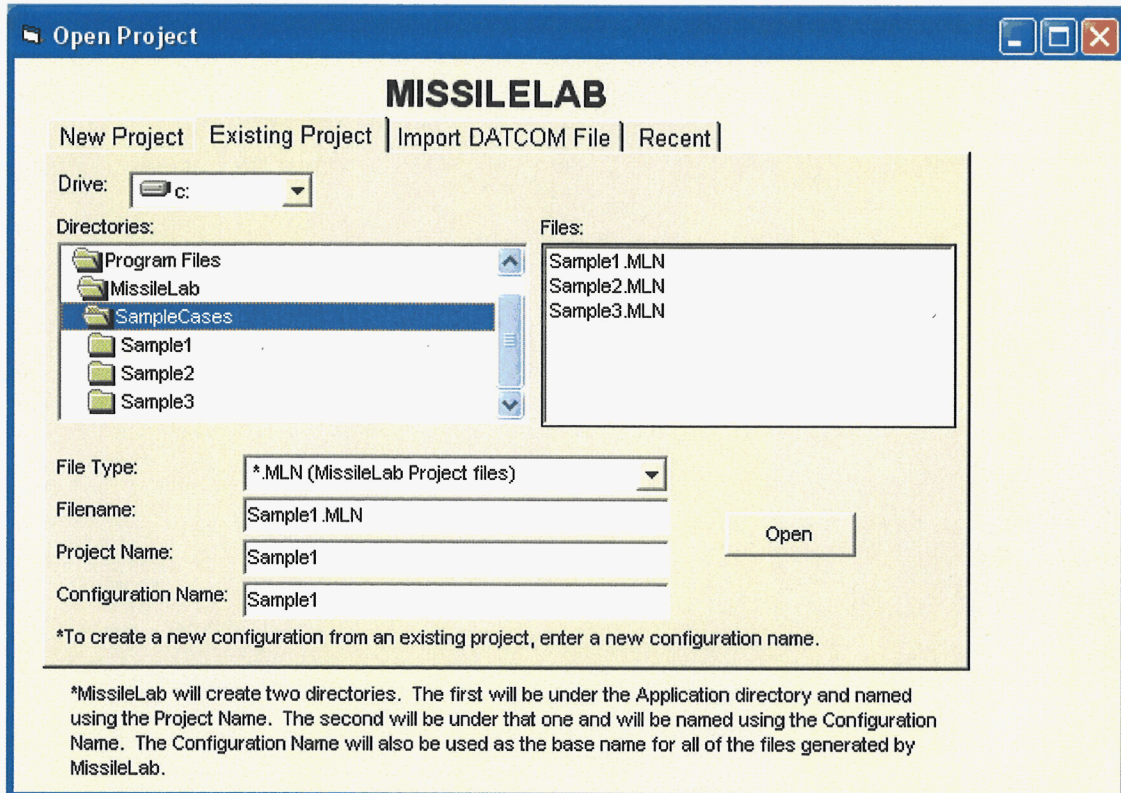

Figure 6. Project File Screen

Change Note:

Recently Used MissileLab files are now stored in the file named “MLRecentFiles.ini” which is located in the directory where the MissileLab executable is installed. Earlier versions of MissileLab stored recently used files in the Windows Registry.

1. Creating a New Project

The “New Project” screen shown in Figure 7 creates a new blank project for the user.

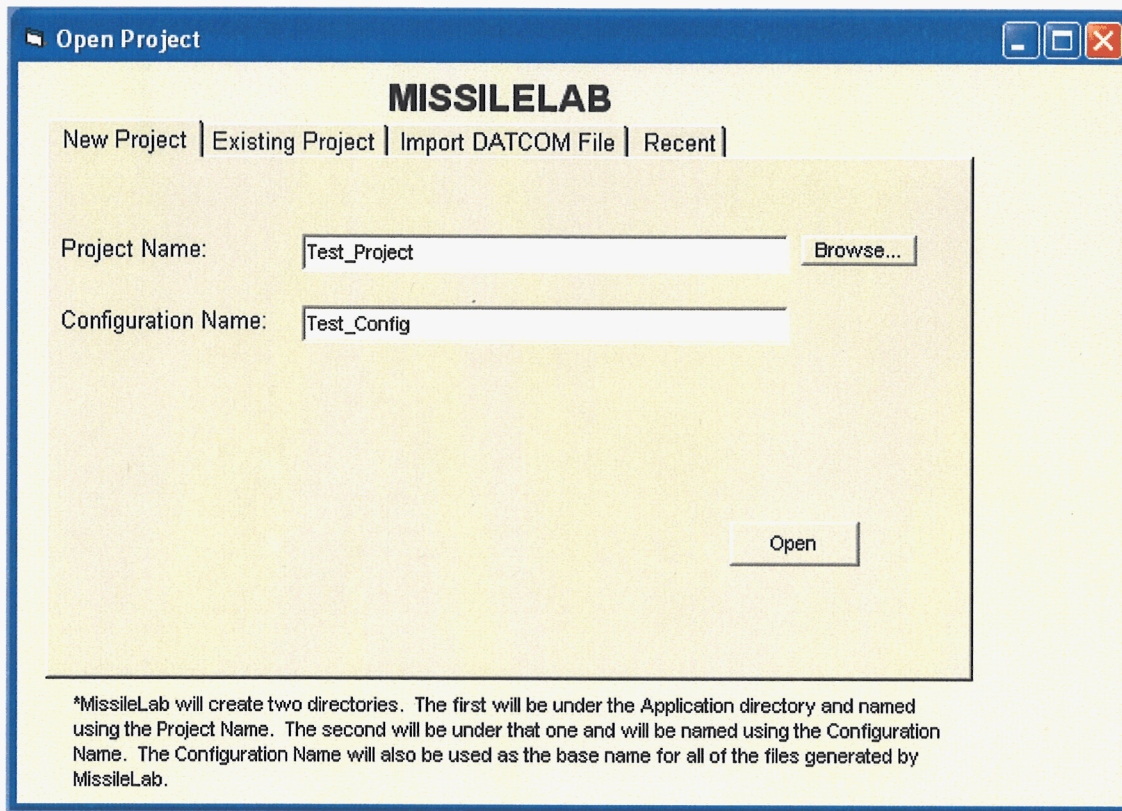

Figure 7. New Project Screen

2. Opening an Existing Project

The “[Existing Project](#)” screen shown previously in Figure 6 opens an existing MissileLab file. The user may also open an existing project file and rename it by entering a new configuration name in the “[Configuration Name](#)” text box or a new project name in the “Project Name” text box.

3. Importing a Missile DATCOM File

MissileLab can read (import) existing Missile DATCOM namelist files. MissileLab attempts to detect (and correct if possible) common typographical input errors in the DATCOM file (such as missing or misplaced commas). MissileLab also attempts to identify, correct, and warn the user if it detects typical geometry input errors. Significant changes that are made by MissileLab when reading in an existing DATCOM file will be followed with a “confirmation” warning message.

Figure 8 presents the DATCOM import screen. As with the open existing projects option, the user may rename the configuration and/or project name by entering a new name in the appropriate text box.

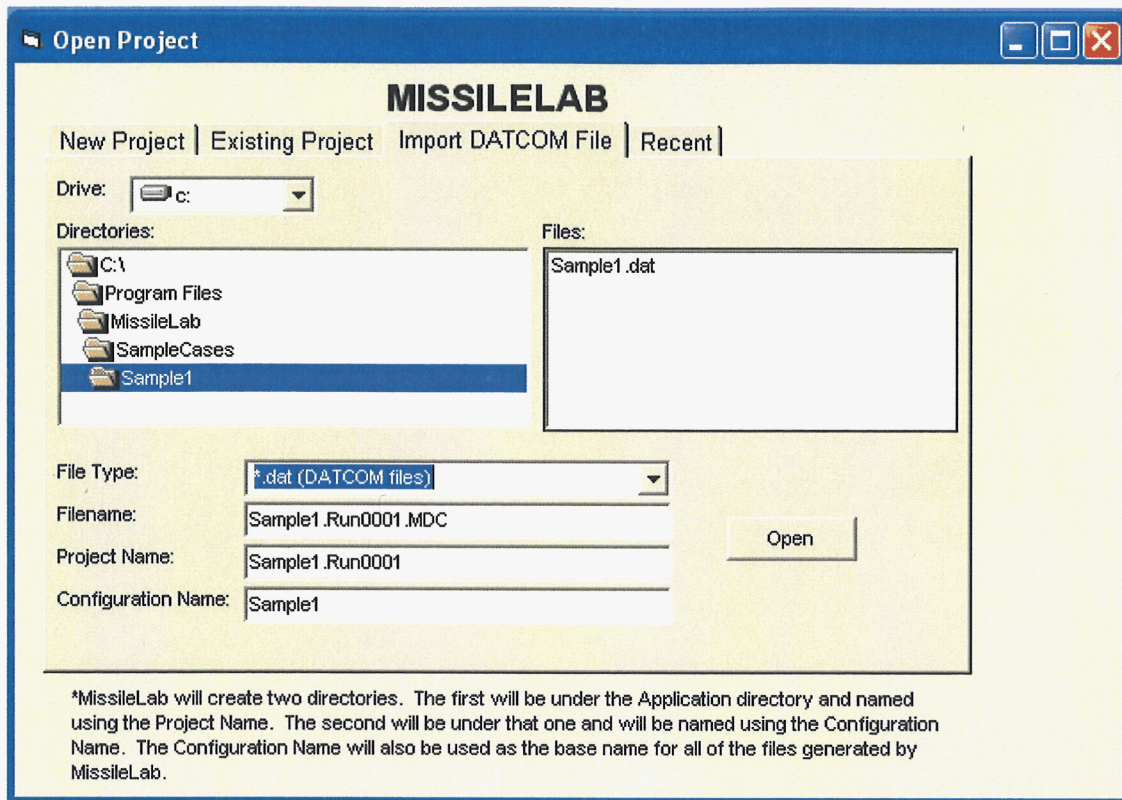

Figure 8. DATCOM Import Screen

If the user imports an existing DATCOM file where the body has been defined using the DATCOM “Axibod Option 2” method, then an additional screen appears. This screen, shown in Figure 9, is used to associate the input points with their respective body segment as required for compatibility with the AP codes. In the example shown in the figure, the first three points were “assigned” to the nose by selecting the points (“left clicking” on point 1, holding down the <SHIFT> key and “left clicking” on point 3), then “right clicking”. The “right click” of the mouse pops-up a “copy to” menu that allows the user to select the nose, midbody section 1 through 4, or the aft body (boattail) section. After points have been copied to body segments, they can then be deleted from the segment or moved to a different segment by selecting them and “right clicking” the mouse and choosing the appropriate pop-up menu option. Once all points have been assigned to a section, the user clicks on the “OK” button.

APxx’s requirements for certain number of points in certain segments can be a little tricky, and so the user is referred to the AP05 User’s Guide for additional information as to AP’s requirements for points per segment.

As far as DATCOM is concerned these points are handled in the standard way for Axibod Option 2. As seen in Figure 9, certain cells are colored yellow. These yellow cells correspond to points where the DATCOM “DISCON” flag is set to 1 indicating that the slopes at those points are not continuous. Neither the body geometry nor the DISCON flags can be changed on this screen, but they can be changed on the MissileLab “Body Geometry” screen which will be discussed in Section III.C.3.

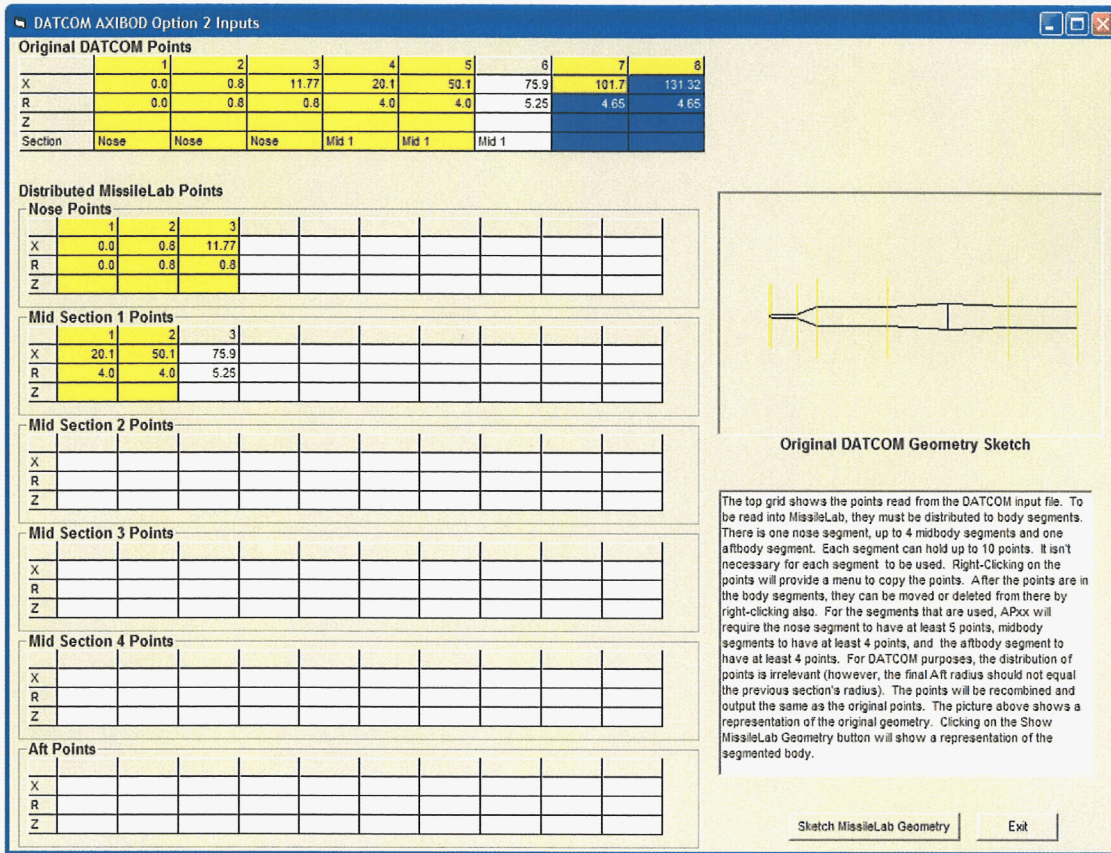

Figure 9. DATCOM Axibod Option 2 Import Screen

4. Opening Recent MissileLab Files

Figure 10 presents the recent files screen. As with the open existing projects option and the Import DATCOM option, the user may rename the configuration by entering a new name in the “**Configuration Name**” and/or “**Project Name**” text box. Note that both “.mln” project files and DATCOM input files are listed here.

The list of recently used files is stored in the “MLRecentFiles.ini” located in the directory where the MissileLab executable is installed.

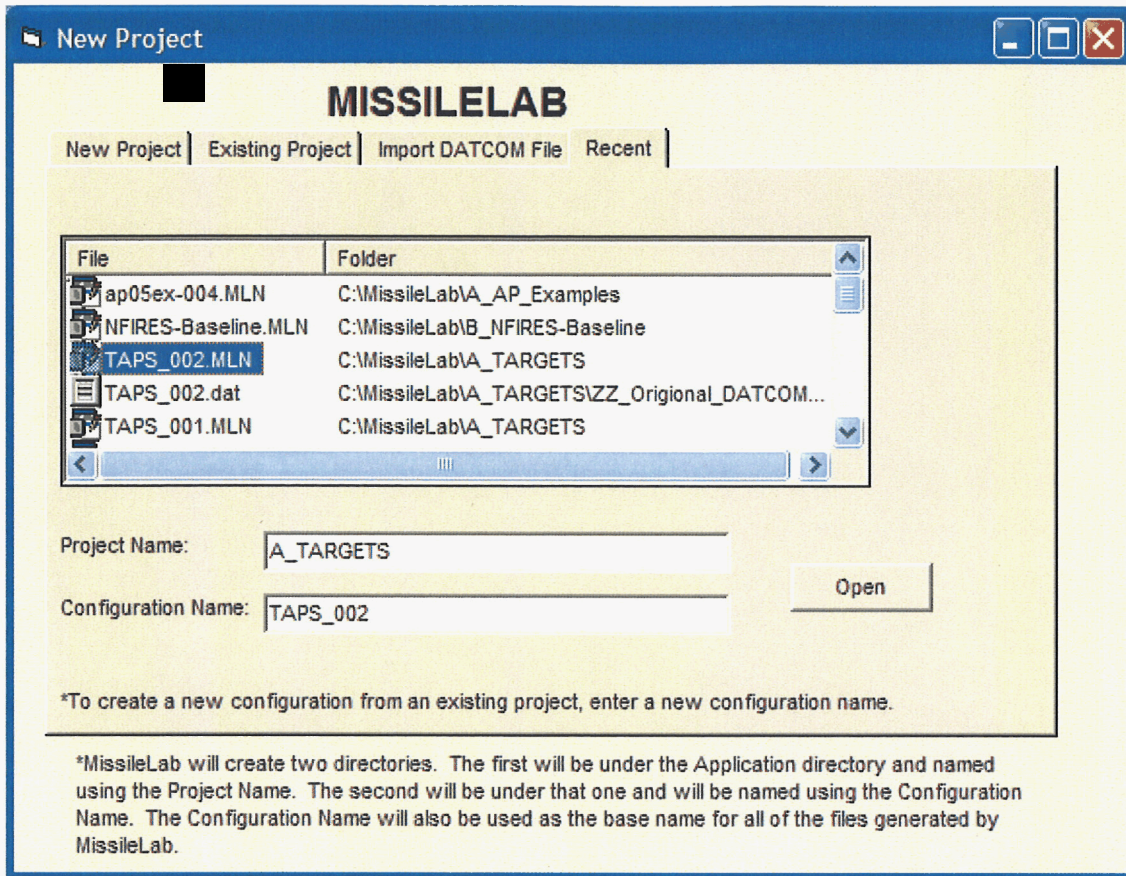

Figure 10. Open Recent Files Screen

C. Sketching Geometry

Any time after geometry has been defined, the missile can be viewed graphically using the “Sketch” menu option. Under this menu, there is a “Sketch 3-D Missile” option. This will only be enabled when the appropriate libraries can be found, and the “Include 3-D Graphics” option is selected on the “Locate Manuals” screen. The 3-D solid model sketcher is shown in Figure 11. Here, functionality is provided to zoom in and out (right mouse button), rotate the camera around the fixed body (left mouse button), and pan (<SHIFT> plus left mouse button). Detailed instructions for controlling the 3-D view can be found in the “Help” section on the screen.

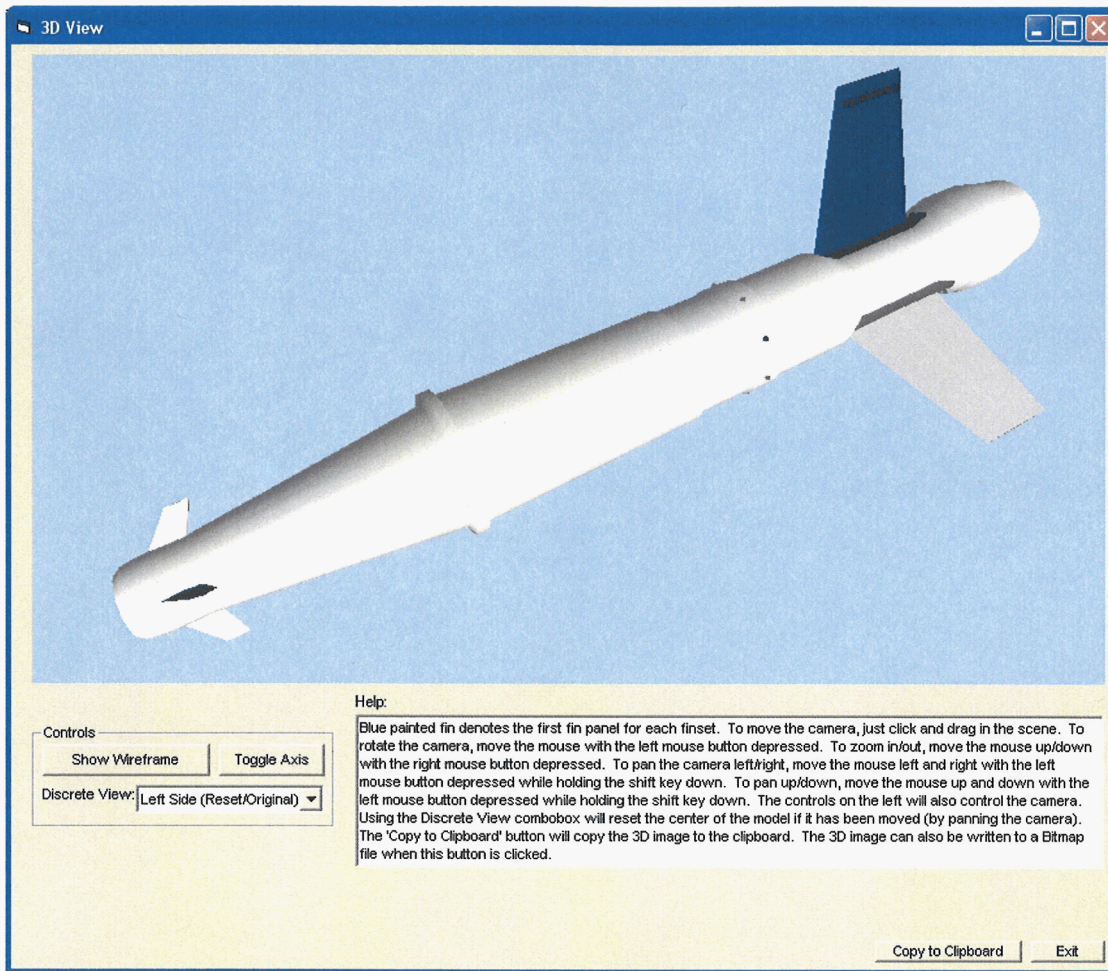

Figure 11. Sample MissileLab 3-D Sketch

MissileLab contains a simple 2-D sketch feature that is accessed via the “Sketch” menu. The user can sketch the body, an individual fin, or both, by using the appropriate menu option. In the 2-D sketches, the body cross-section is always drawn as a circle using the defined radius (or half-width for non-circular cross-section). For an accurate depiction of a non-circular cross-section, see the 3-D sketches discussed above. The 2-D sketches provide various dimensions provided in labels. The user can click on the labels with the left mouse button and drag these to a new location. A sample sketch of both body and fins is presented in Figure 12. For each finset (when finsets are displayed), a box is displayed that shows the panel orientation and/or dihedral (looking from the rear of the missile). As seen in Figure 12, various user controls are provided. There is a button at the bottom of the screen that allows the user to copy the sketch to the clip-board so that it may be pasted into any Windows application that supports Windows Meta Files. A sample of the pasted Windows Meta File is presented in Figure 13. Also, check-box controls allow the user to turn on and off the panel displays and the body station information on the sketch, as well as allow the user to highlight body discontinuities and/or the Moment Reference Point (MRP). Another control enables a text screen to display body geometry data. When finsets are displayed, a control enables the leading edge locations to be shown.

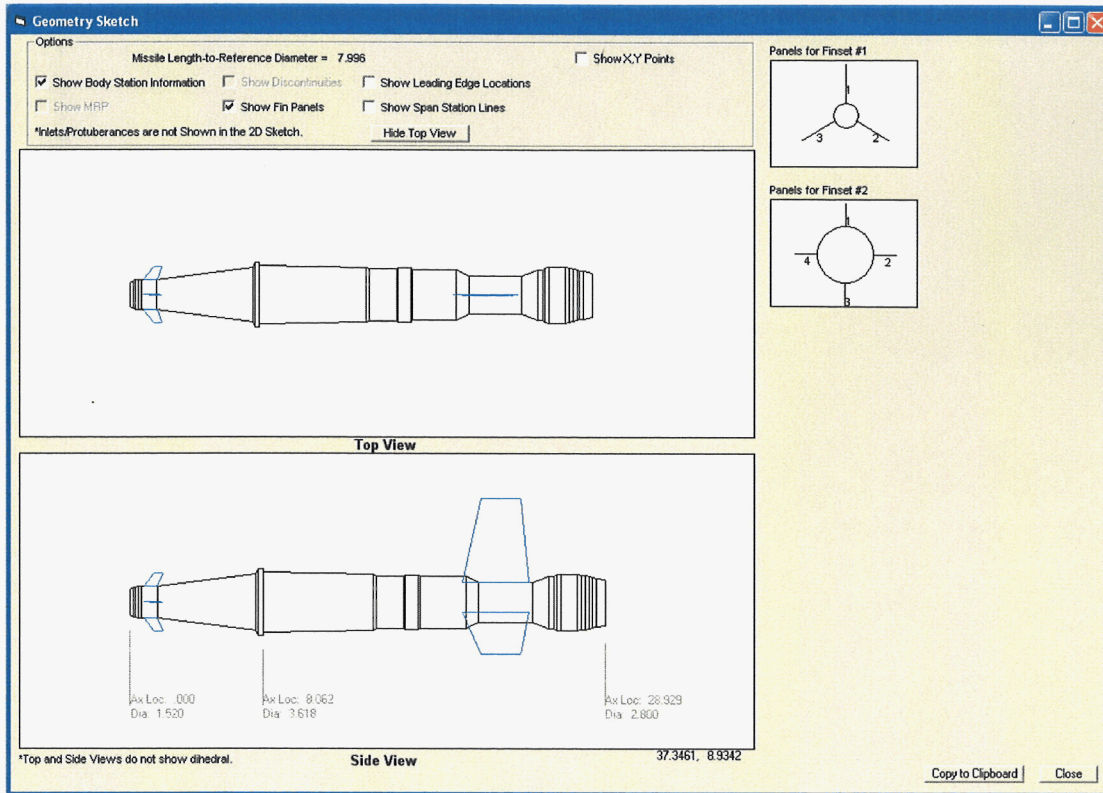

Figure 12. Sample MissileLab Sketch

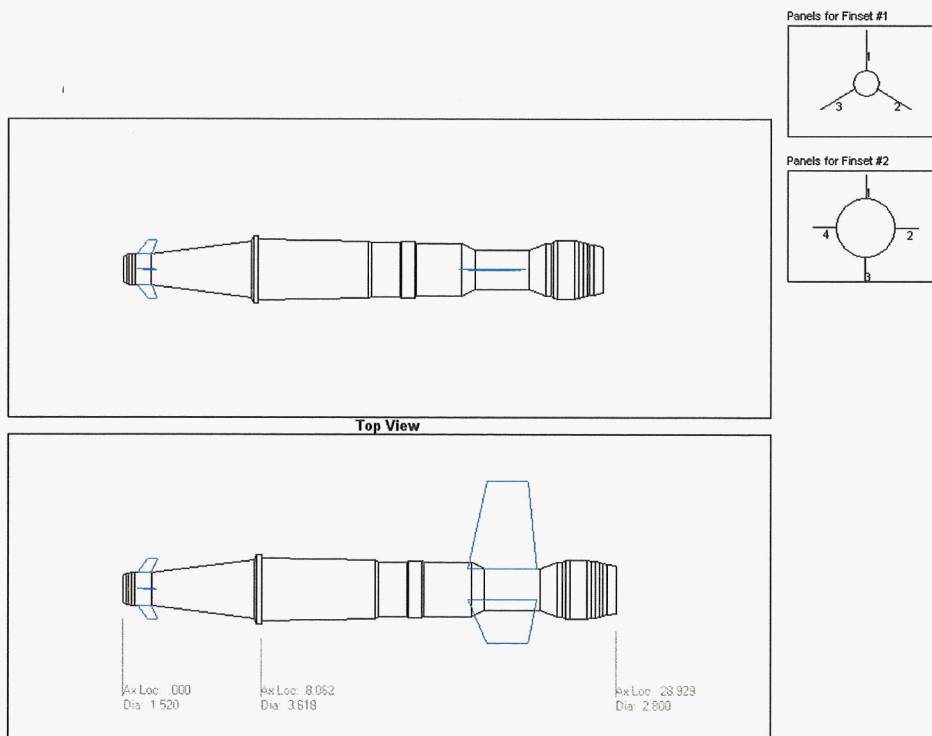

Figure 13. Sample MissileLab Sketch via Meta File

An individual finset can be displayed by using the “Sketch Fin” menu option. An example of this sketch is shown in Figure 14. The controls described above that are appropriate are also present on this screen. An additional check-box control is provided to set the leading edge location to 0.0. The blue striped area represents the trailing edge flap.

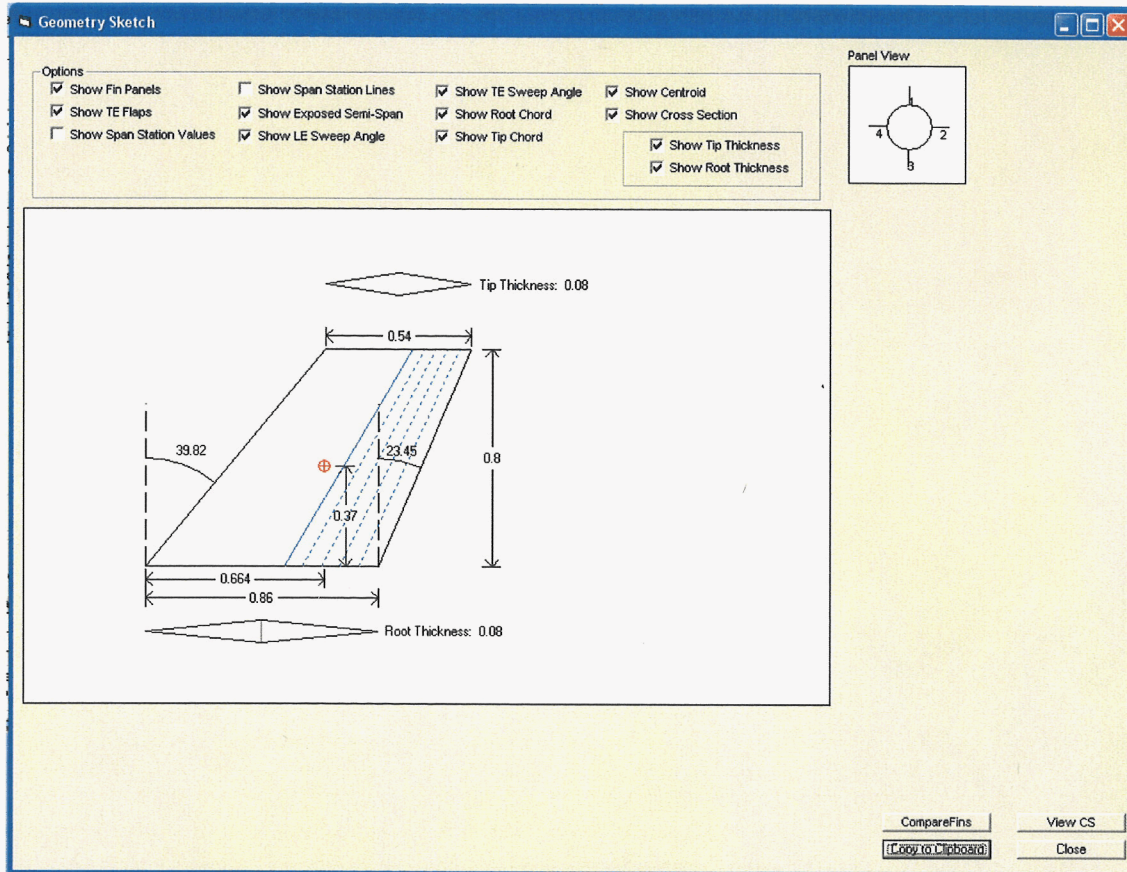

Figure 14. Sample MissileLab Fin Sketch

D. Entering MissileLab Geometry in the GUI

Figure 15 presents MissileLab’s main interface screen with focus on the “Input Units” screen. As seen in this figure, the screen is divided into three panels: the Menu Options Panel (upper-left), the Help Topics Panel (lower-left), and the Work Area Panel (right; in this case displaying the Input Units panel).

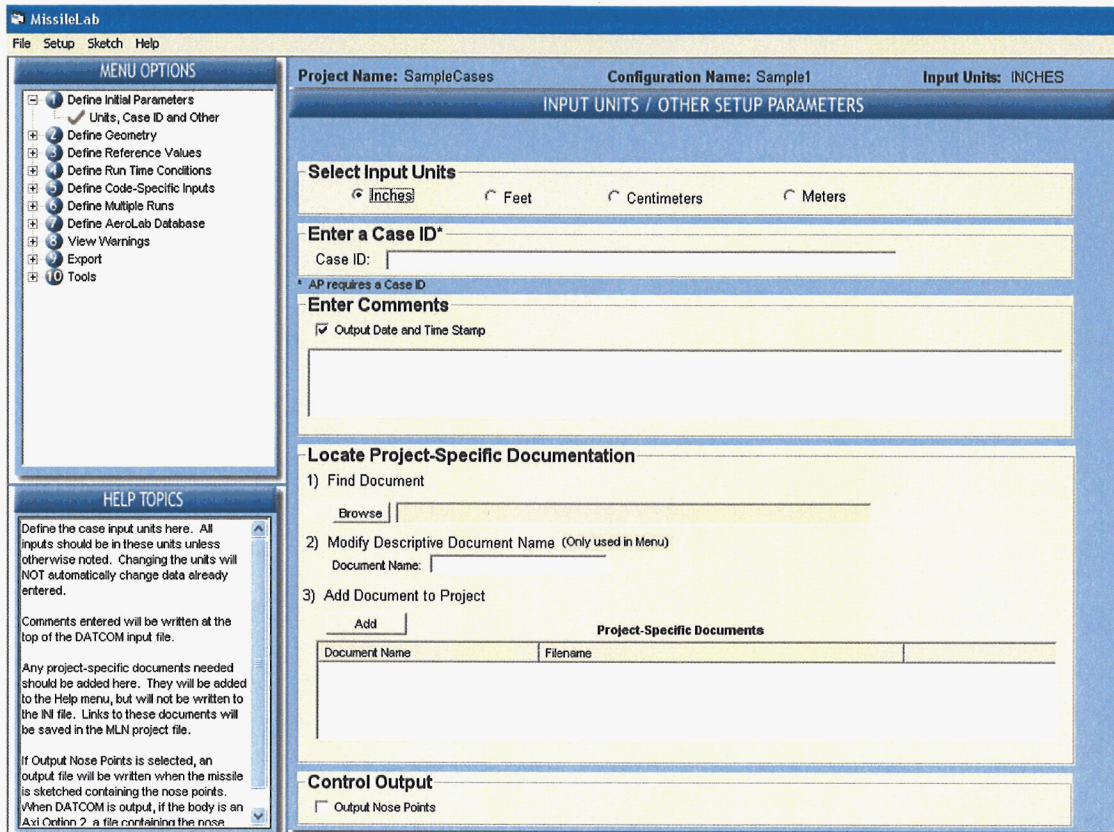

Figure 15. Units and Case Identification (ID) Screen

Notice that the menu options panel, located in the upper-left of the screen, is an expandable list that guides the user through the steps required to generate a valid input deck. Table 3 lists the contents of the menu options panel. While this is a numbered list of the recommended data entry steps, the user may enter the data in any order, may return to any screen at any time during the input definition process, and may save the project configuration file at any point in the process. When a menu option is selected, the appropriate panel will be displayed in the “Work Area” that forms the right-hand side of the screen.

Table 3. Menu Options Panel

- (1) **Define Initial Parameters**
 - Units, Case ID, and Other
- (2) **Define Geometry**
 - Body
 - Finsets
 - Protuberances
 - Inlets
- (3) **Define Reference Values**
 - Body References
- (4) **Define Run Time Conditions**
 - Geometry Parametrics
 - Flight Conditions
 - Deflection / Trim
 - Base Effects
 - Inlet Additive Drag
- (5) **Define Code Specific Inputs**
 - DATCOM Specific Inputs
 - Prediction Method/Case Computations
 - Output Options
 - Common Block Output
 - Define APxx Specific Inputs
 - Run Time Conditions
 - AP05 Protuberance Inputs
 - Define NEAR MISL3 Specific Inputs
 - Run Time Conditions
 - Body Loads / Rotation Rates
 - Define HASC Specific Inputs
 - Run Time Conditions
 - Define NEAR MISDL Specific Inputs
 - Fin Parameters
 - Run Time Conditions
- (6) **Define Multiple Runs**
 - Run Manager
- (7) **Define AeroLab Database**
 - Configure AeroLab Database Parameters
- (8) **View Warnings**
 - DATCOM Warnings
 - AP Warnings
 - MISL3 Warnings
 - HASC Warnings
 - MISDL Warnings
- (9) **Export**
 - Export Data Files / Run Predictions
 - Export 3D Geometric Files
- (10) **Tools**
 - Quick Look Plots
 - View Data / Create Database
 - Estimate Mass Properties

The help topics panel, located directly below the menu options panel, displays information the user may need while entering data on the given screen. Note: Additional help information may be accessed via the pull-down Help menu item located in the menu bar at the top of the screen. From that menu, the user can access any number of previously user-defined text documents to aid in understanding the required input fields.

Helpful Hint: Help Topics

To increase the font size in the Help Topics panel, click in the panel, hold down the <CTRL> key, and rotate your mouse wheel.

This is a Microsoft Windows feature and may be useful in other applications such as Microsoft Windows WordPad.

The work area panel displays the fields to be completed by the user. Once the user leaves the current work area panel, a checkmark appears by the associated panel name in the menu options panel, indicating that the user has visited the given panel during the current session. If the current configuration is closed and then re-opened, all checkmarks are re-set.

All value-based text box entry fields (even those in grids) will accept equations as valid entries. These expressions are evaluated and the resulting value is placed in the text box field. For example, entering the expression “10. – 6/2” will be evaluated by MissileLab and the value of “7.00” will be placed in the field. A list of supported functions is presented in Figure 16 and may be accessed from MissileLab under the Help menu item.

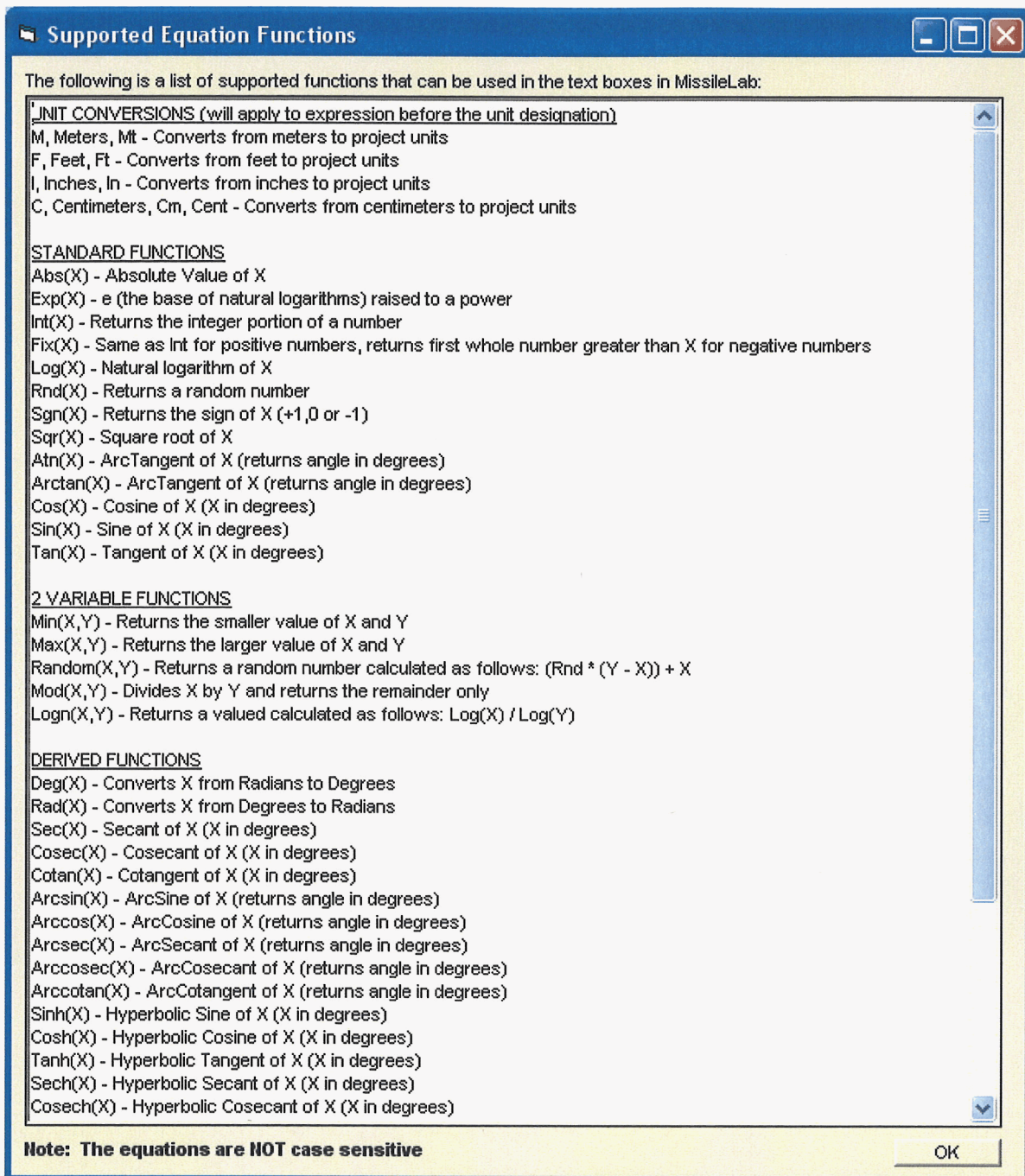

Figure 16. Supported Text Box Equation Functions

1. Define Initial Parameters Screens

Units, Case ID, and Other Screen: The user defines the input units (default = inches), configuration case ID (required input for the AP codes), comments regarding the configuration (optional), and project-specific text reference files (optional) on the “Units, Case ID, and Other” screen shown in Figure 15. As previously discussed in Section III.A.2, text files defined on the “Set-Up” screen are always available via the “Help” menu, whereas the text files that are defined on the “Input Units” screen shown in Figure 15 are only available for the specific project where they were defined. Additionally, whereas the text files that are defined on the initial set-up screen are stored in the MissileLab initialization file, the PDF files defined on the project screen shown in Figure 15 are stored in the respective MissileLab project file (*.MLN).

2. Define Geometry Screens

Body Screen: The standard body geometry definition (Nose+Body+Boattail/Flare configurations) input screen is presented in Figure 17. This panel features a number of pull-down boxes available to the user, and these are summarized in Table 4. Here, the user may specify the cross-sectional shape as axisymmetric (circular), elliptic, square, diamond, or triangular. The APEs have varying capabilities for non-axisymmetric cross-sections. APxx and MISDL can run any of the defined cross-sections. For these codes, the input decks are generated based on the APE documentation. DATCOM can run circular and elliptical cross-sections. NEAR MISL3 only supports a circular cross-section. For all non-supported cross-sections, an equivalent circular body (based on cross-sectional area) is created.

As seen in Figure 17, the body geometry panel is subdivided into nose, center-body, and aft body sections. For each of these sub-panels a geometry pull-down box is provided that allows the user to tailor the required inputs based upon available data. For multi-segmented bodies, as supported by both DATCOM and APxx, the user may define up to four center-body segments (a total of six segments including the nose and boattail/flare). The majority of the MissileLab input fields are automatically mapped to the respective locations for the various aerodynamic prediction engines. However, as each APE has its own unique capabilities and input requirements, MissileLab lists APE code-specific variables separately for the user. The Body page provides examples of these. The “Height of Rotating Band” input is designated for APxx only. The “Corner Radius” (only necessary for square or triangular cross-sections) and “Transition Length” (only necessary for a body with two different cross-section shapes) apply to APxx and the 3-D models.

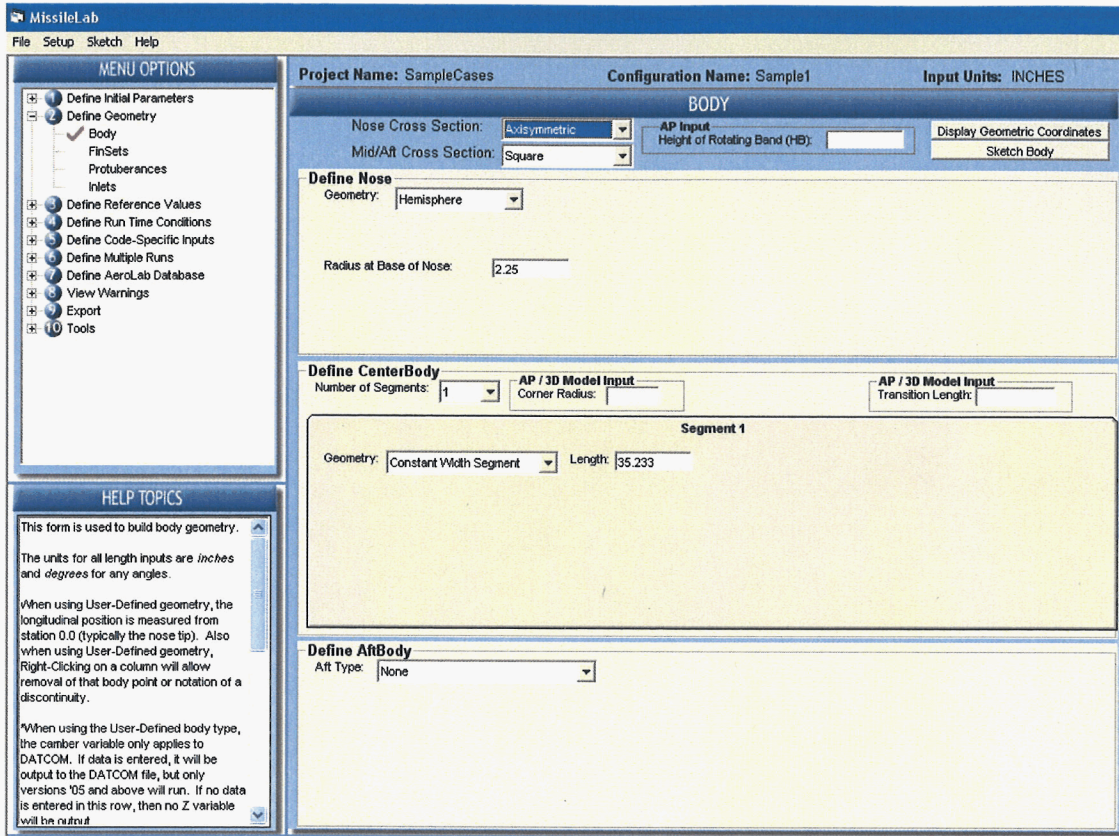

Figure 17. Body Geometry Screen

Table 4. Body Screen Pull-Down Fields

Field	Choices	Comments
Cross-Sectional Shape	Axisymmetric..... Elliptical..... Square..... Diamond..... Triangle..... Inverted Triangle.....	All APEs Specific to DATCOM, APxx, MISDL Specific to APxx, MISDL Specific to APxx, MISDL Specific to APxx, MISDL Specific to APxx, MISDL
Nose Geometry	Ogive Conical Power Haack Karman Hemisphere Secant Ogive User Defined	A hemisphere can be modeled as a Tangent Ogive, however as APxx input files are slightly different for the hemispherical case it is recommended that the HEMISPHERE option be used when modeling a hemispherical nose. Secant Ogive and User Defined options force DATCOM into Axibod Option 2 mode.
Nose Tip Geometry	Pointed Blunted Truncated	The corresponding length for all nose tip geometries is the physical length of the nose (after blunting or truncating).
Number of Body Segments	1 to 4	Any value other than 1 forces DATCOM into Axibod Option 2 mode.
Center Body Geometry	Cylinder Cone – known radius Cone – known half-angle User Defined	User Defined options force DATCOM into Axibod Option 2 mode.
Aft Body Geometry	None Tangent Ogive Cone – known radius Cone – known half-angle User Defined	User Defined options force DATCOM into Axibod Option 2 mode.

NOTE: Non-Axisymmetric Nose and Body

If the nose or body is not a “revolved” part, then several additional fields appear that allow the user to enter corner radius and transition length values. **The Transition Length is part of the body length!** So if the configuration is 10 calibers in total length, with a 3-caliber nose, and 1-caliber transition length, then the 1-caliber transition length is part of the 7-caliber body.

For cases where the body cannot be modeled by a simple nose+body+aft section, MissileLab allows the user to enter body point pairs, X & R (longitudinal ‘X’ station and radial ‘R’ station). For those familiar with Missile DATCOM this would be the “Axibod Option 2” input method, and for those familiar with AP this corresponds to the “Other” nose and body input method. Figure 18 presents an example of this screen.

The 2006 (and later) version of Missile DATCOM includes the capability to predict aerodynamic trends of a cambered (or bent) body at zero roll angle^[17]. This new DATCOM capability introduced a new “Z” input variable as part of the Axibod Option 2 “X” and “R” variables. MissileLab allows for this variable using the “Camber” field shown in Figure 18.

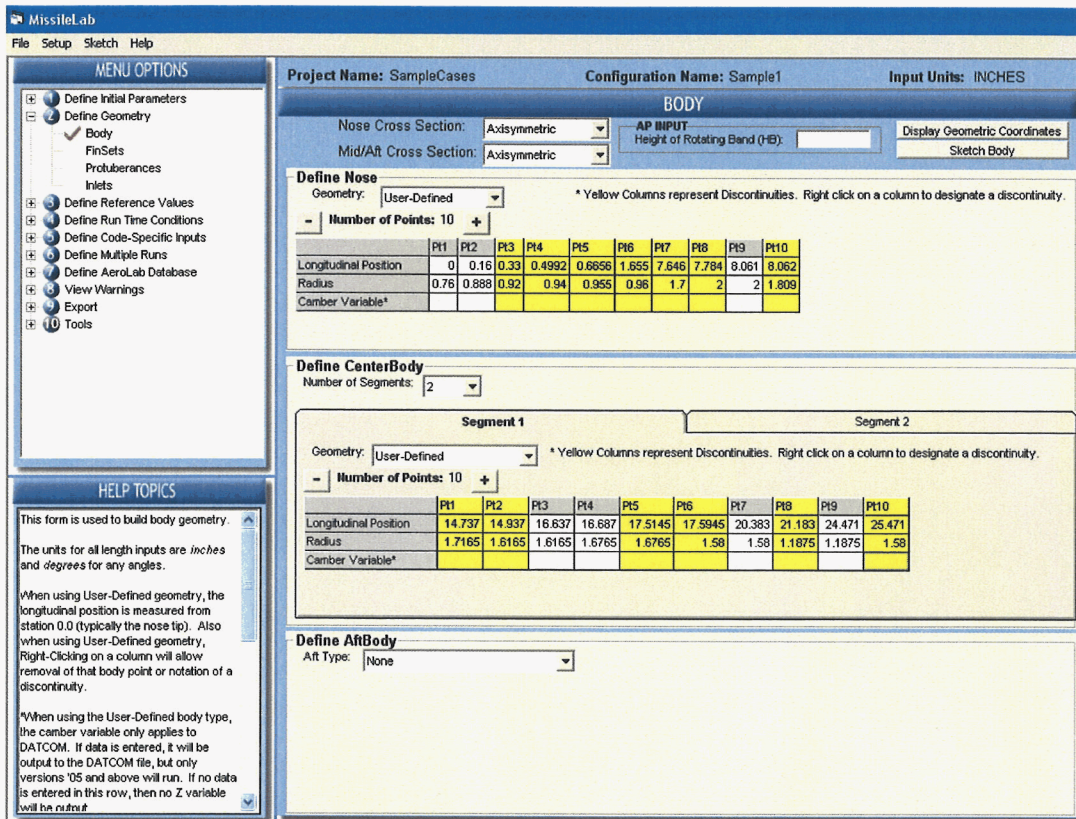

Figure 18. User-Defined Body Input Screen

From this screen it is seen that some of the user-defined body point cells are colored yellow while some are colored white. Yellow shaded cells indicate points that do not have a continuous slope. In Missile DATCOM, these points would have the DISCON namelist variable set to a value of 1. The discontinuity slope flag may be toggled on and off by “left-clicking” on the point number, then “right-clicking.” When this is done, a “pop-up” menu will appear that will allow the user to (1) remove the current point, (2) insert a point before the current point, and (3) toggle the discontinuity flag of the current point.

Each section may have up to 10 pairs of points. This limitation is imposed for compatibility with the AP prediction codes. Up to six sections (one nose, four centerbody, and one aft body) may be entered. As this can lead to 60 discrete body points, and as DATCOM allows for a maximum of 50 body points, points over 50 will disable Missile DATCOM from running. It is noted that the distribution of points in the various sections affects only the AP input files. It is also noted that discrete “steps” are NOT allowed by MissileLab as none of the APE are designed to account for forward/rearward facing steps along the body. Additionally, the user should avoid entering points that will produce “very steep slopes” along the body.

Figure 19 presents the body points display window. This screen is for point “inspection” alone and has no functionality other than allowing the user to view all the points in all the sections “in order.” This screen will open automatically when more complex or user-defined geometry is defined. It can also be displayed using the “Display Geometric Coordinates” button near the top right of the panel.

	Pt1	Pt2	Pt3	Pt4	Pt5	Pt6	Pt7	Pt8	Pt9	Pt10	Pt11	Pt12	Pt13	Pt14	Pt15	Pt16	Pt17	Pt18	Pt19	Pt20	Pt21
	Nose	Nose	Nose	Nose	Nose	Nose	Nose	Nose	Nose	Nose	Mid	Mid	Mid	Mid	Mid	Mid	Mid	Mid	Mid	Mid	Mid
Longitudinal Position	0.00	0.16	0.33	0.4992	0.6656	1.855	7.646	7.784	8.061	8.062	14.737	14.937	16.637	16.687	17.5145	17.5945	20.383	21.183	24.471	25.471	25.77
Radius	0.76	0.888	0.92	0.94	0.955	0.96	1.70	2.00	2.00	1.809	1.7165	1.6165	1.6165	1.6765	1.6765	1.58	1.58	1.1875	1.1875	1.58	1.5
Camber Variable																					

Figure 19. User-Defined Body Points Screen

Below the “Display Geometric Coordinates” button, there is a “Sketch Body” button. This will display the same sketch as the “Sketch Body Only” menu option described in Section III.C.

FinSets Screen: Figure 20 presents the fin geometry input screen. Up to nine finsets may be specified using the pull-down box at the top of the screen. The current finset can be sketched using the “Sketch Fin” button at the top right corner of the panel. This displays the same sketch as the “Sketch Fin” menu option described in Section III.C. As seen in Figure 20, many fin geometry variables follow the DATCOM namelist inputs. One difference is that most of the non-dimensional DATCOM inputs are entered into the grid as dimensional. To define trailing edge flaps, the “TE Flaps” checkbox must be checked. NEAR MISL3 does not support trailing edge flaps. If a finset is defined with flaps, MissileLab will give a critical error for MISL3, and will not export the input file for MISL3. Notice the code-specific inputs at the bottom of the “Define Fin” frame.

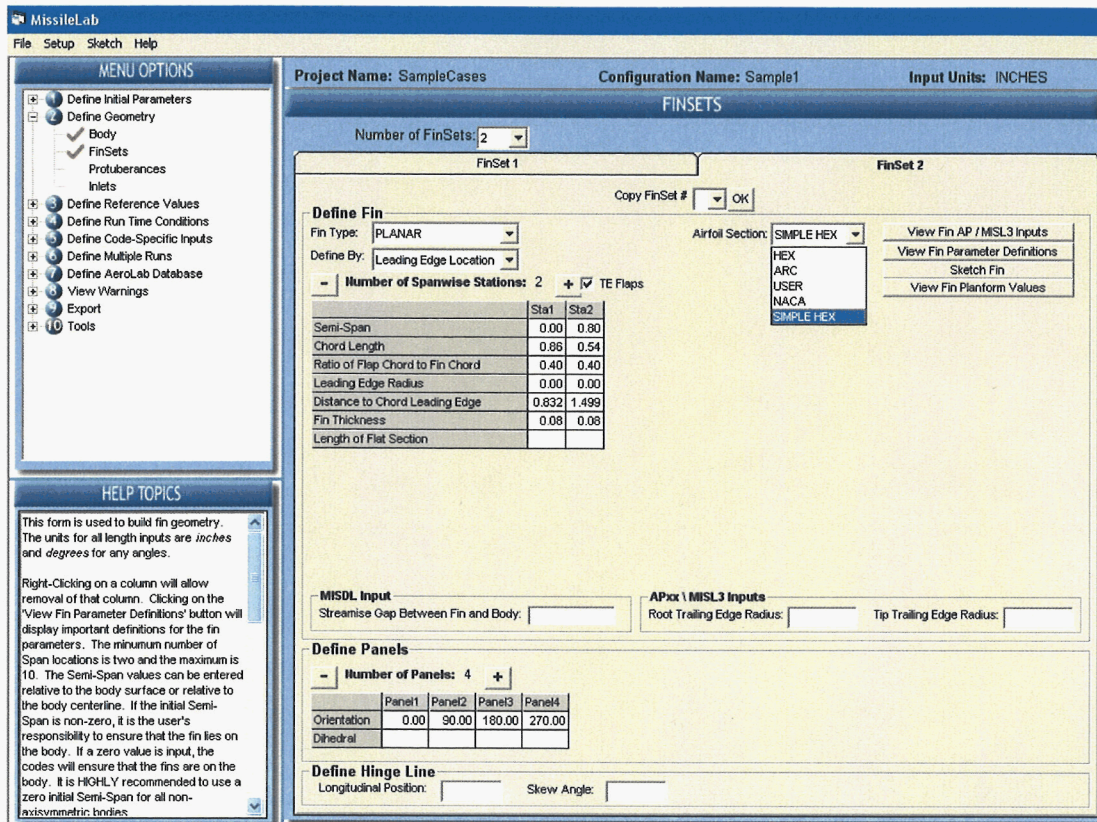

Figure 20. Fin Geometry Screen

NOTE: Number of Finsets

Because each APE supports a different number of finsets, the Geometry Parametrics page (discussed in greater detail in *Section III.D.4*) provides options for enabling/disabling finsets for each code. If more than two fin sets are specified, the user must specify on the Geometry Parametrics Screen which TWO fin sets are to be run for the APxx APes. If more than three fins are specified, the user must specify on the Geometry Parametrics Screen which THREE fin sets are to be run for the NEAR MISL3 APE, and which THREE fin sets are to be run for MISDL. Please note that versions of DATCOM prior to August 2008 only support four finsets, while later versions will support nine finsets ^[18].

MissileLab (version 8 and above) supports the definition of WrapAround Fins (WAF). A “simple WAF” is one that is defined using a single curvature angle. A “polyhedral WAF” is one that has varying curvature. The “Fin Type” pull-down defines whether the fin is Planar or a Simple WAF, or a Polyhedral fin. Figure 21 describes the definitions for these fin types. Clicking on “View Fin Parameter Definitions” provides this graphical explanation of the variables needed for WAFs, as well as definitions of other fin parameters.

The direction of the WAF curvature can be changed for each fin in a finset by Right-Clicking on the “Panel” column. If the direction of the curvature is changed, the panel column will be highlighted in yellow.

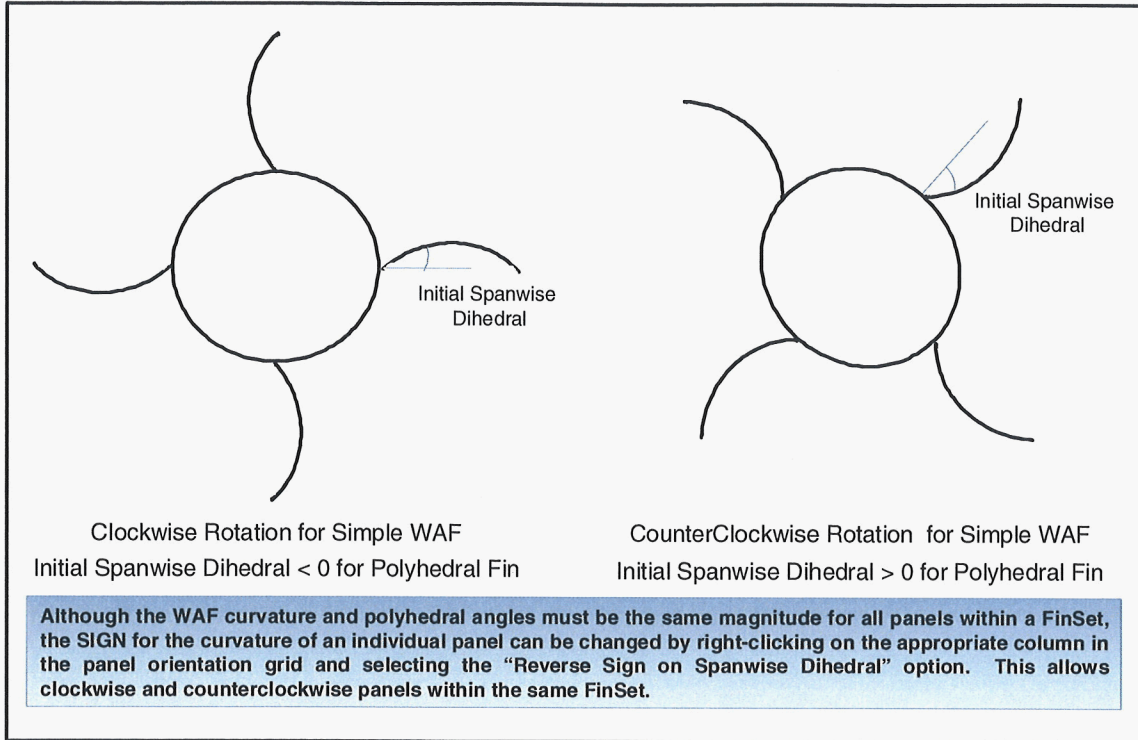

(a)

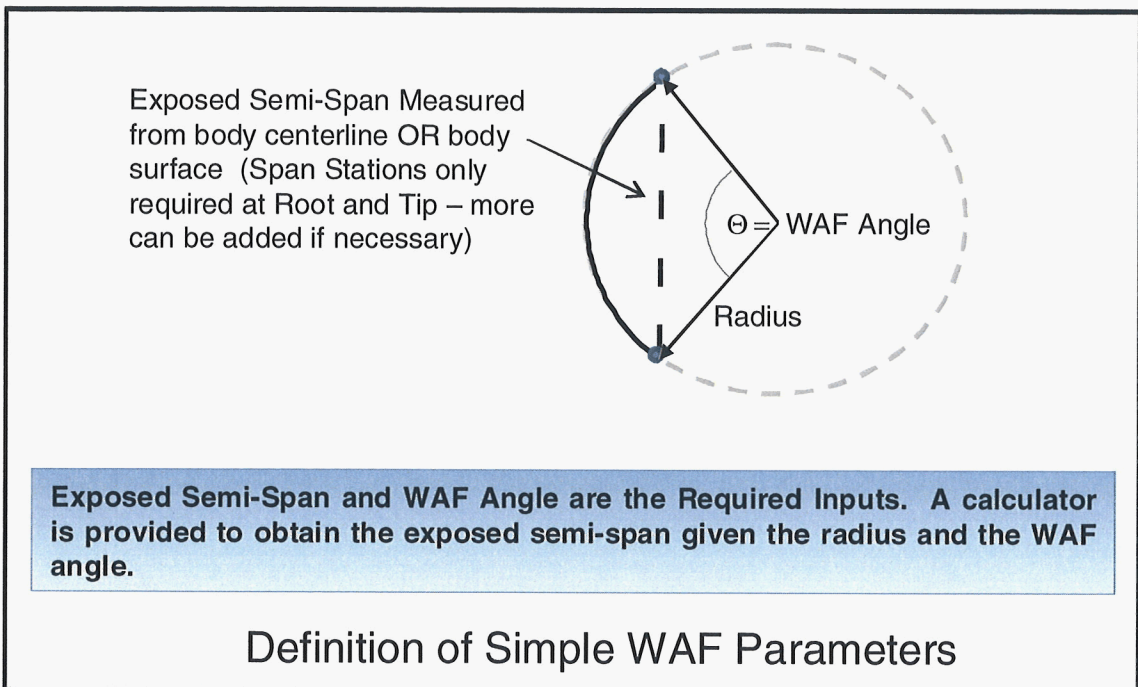

(b)

Figure 21. Definitions of WAFs

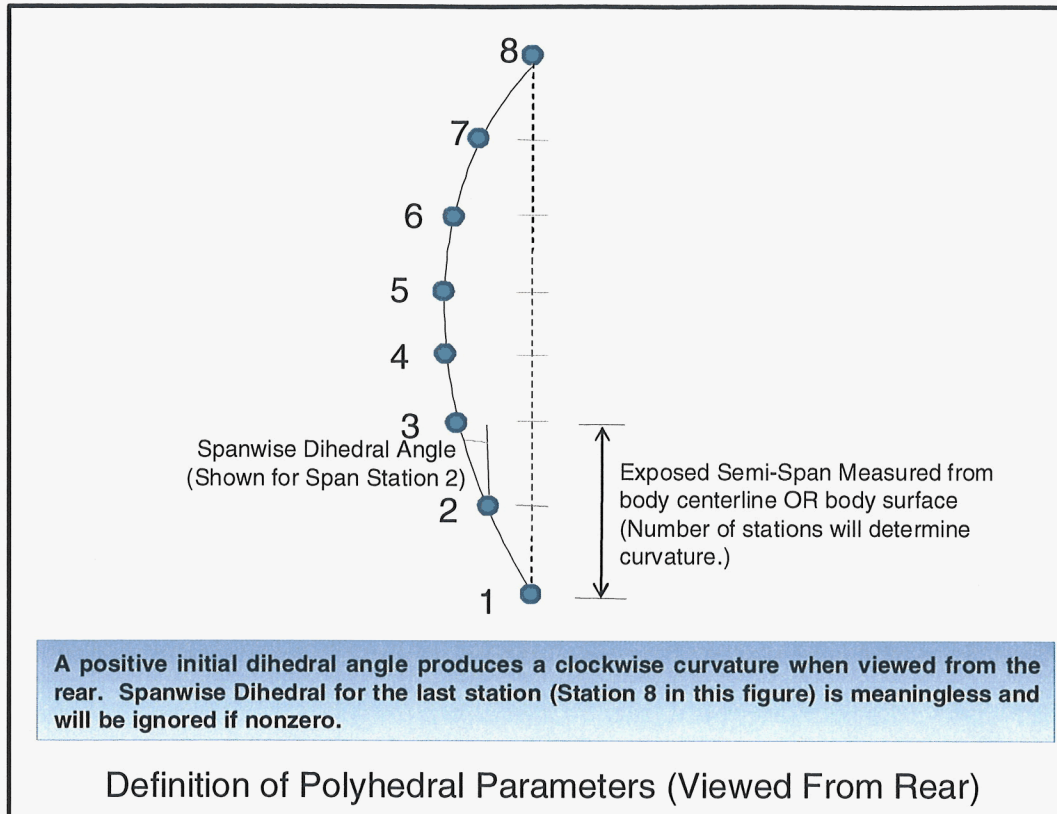

(c)

Figure 21. Definitions of WAFs (Concluded)

Like DATCOM and MISDL, MissileLab allows for multi-segmented lifting surfaces. As this feature is not supported by APxx and NEAR MISL3, routines have been added to MissileLab that create an equivalent single-segment wing panel^[13]. This method involves modifying the leading edge sweep angle and tip and root chords while keeping the taper ratio, trailing edge sweep angle, span and planform area constant. Regardless of the number of segments in the wing panel, a command button is provided that allows the user to view the wing geometry as it would be entered into APxx and NEAR MISL3, as shown in Figure 22. The user cannot change the values shown on this page. If the user feels these values are incorrect, then the values must be changed on the main finset page. The “Sketch Fin Planform” button will show the defined fin (denoted as DATCOM, HASC and MISDL Fin) beside the equivalent APxx and MISL3 fins in a window that is similar to the sketch windows described in Section III.C.

Equivalent Fin Equations

$$Sweep_{LE} = atn \left(\tan(Sweep_{TE}) + \frac{4(1 - Taper\ Ratio)}{AR(1 + Taper\ Ratio)} \right)$$

$$Chord_{Root} = \frac{2 * Planform\ Area}{Span(1 + Taper\ Ratio)}$$

$$Chord_{Tip} = Chord_{Root} * Taper\ Ratio$$

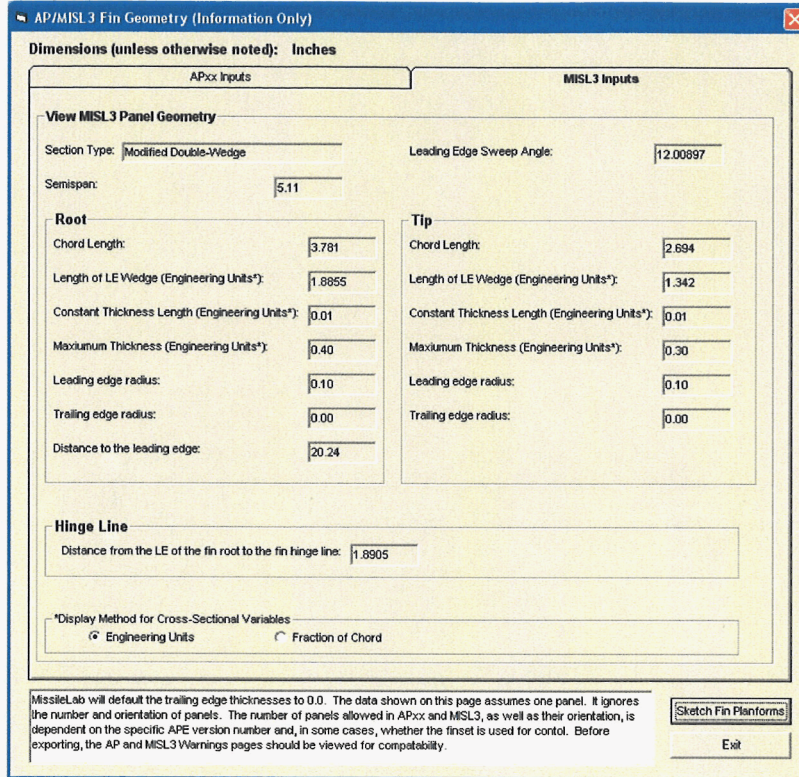

(a)

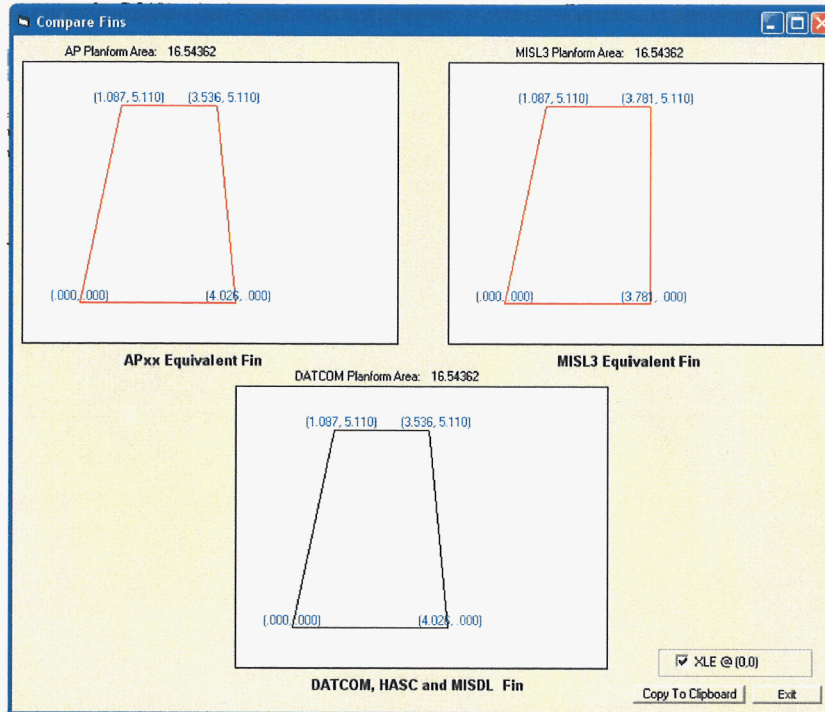

(b)

Figure 22. Equivalent Fin Panel Geometry Screen

Protuberances Screen: The protuberance geometry input screen is presented in Figure 23. Protuberance geometry as specified on this screen is specific to Missile DATCOM and the 3-D model geometry functions, and has no bearing on the input deck generated for APxx, MISL3, MISDL or HASC. Protuberance inputs for AP05 are entered later under the “APxx Specific Inputs” which will be discussed in Section III.D.6.

When the user clicks on the “Add Protuberance” button, the screen shown in Figure 24 appears. The user then selects the type of protuberance that most closely matches the actual geometry and clicks on “OK”. This adds the protuberance type to the protuberance screen, and the actual geometry is then entered. The protuberances can be evenly spaced around the body by selecting the “Default Orientation” option. The “Enter Orientation” option should be selected for all other orientations. After this is selected, clicking on the “Enter/Edit Orientation” button will display the grid shown in Figure 25. The orientation of each individual protuberance around the body is defined here. These orientations are used for the 3-D sketches, and DATCOM version 808 and later [18]. Protuberances are not drawn in the 2-D sketches, but are displayed in the 3-D sketches.

All or specific protuberance geometry can be turned on and off under the “Geometry Parametrics” screen which will be discussed further in Section III.D.4.

NOTE: The 2008 (and later) version of Missile DATCOM introduces the new protuberance input “PHIPRO” that allows the user to define the angular location of a protuberance. DATCOM 808 and later versions use the protuberance axial force to calculate a moment. If PHIPRO is not defined, no moment calculations will be computed.

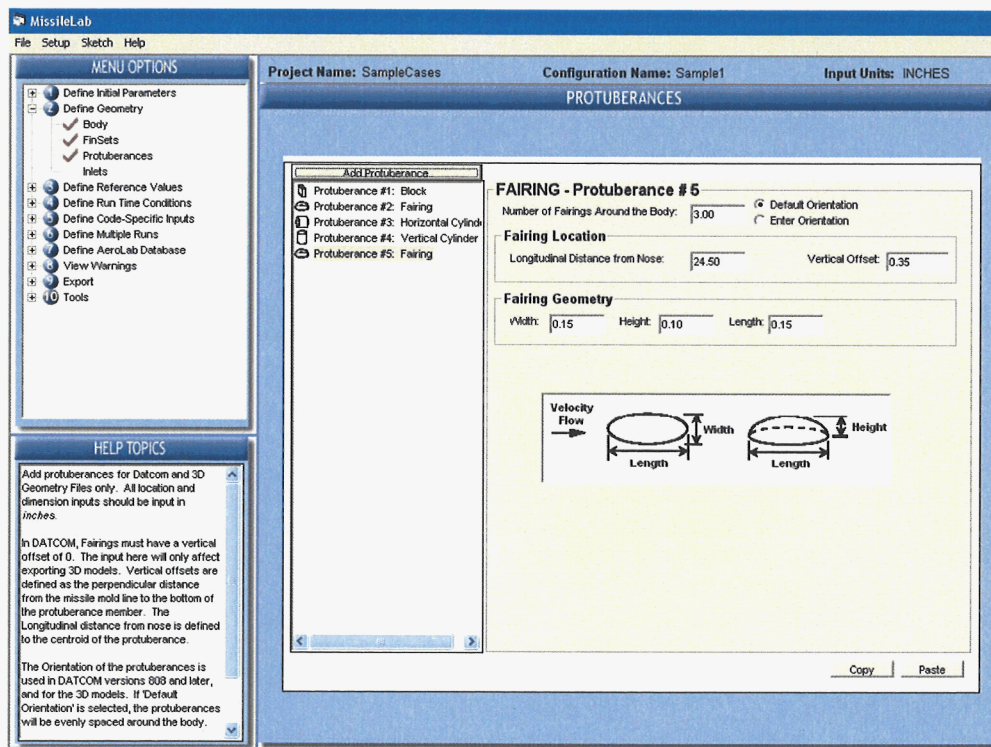

Figure 23. Protuberance Geometry Input Screen

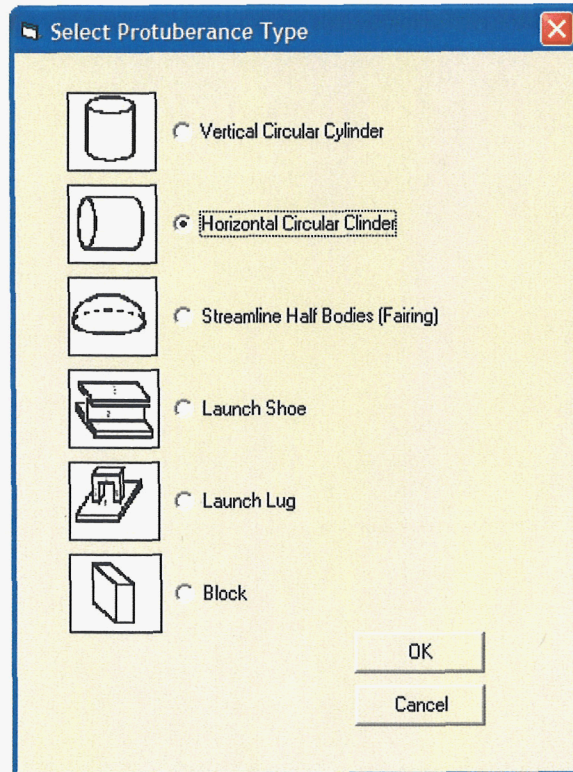

Figure 24. Protuberance Type Selection Screen

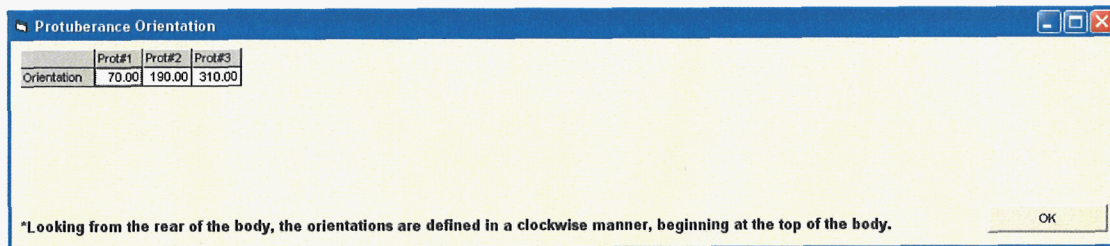
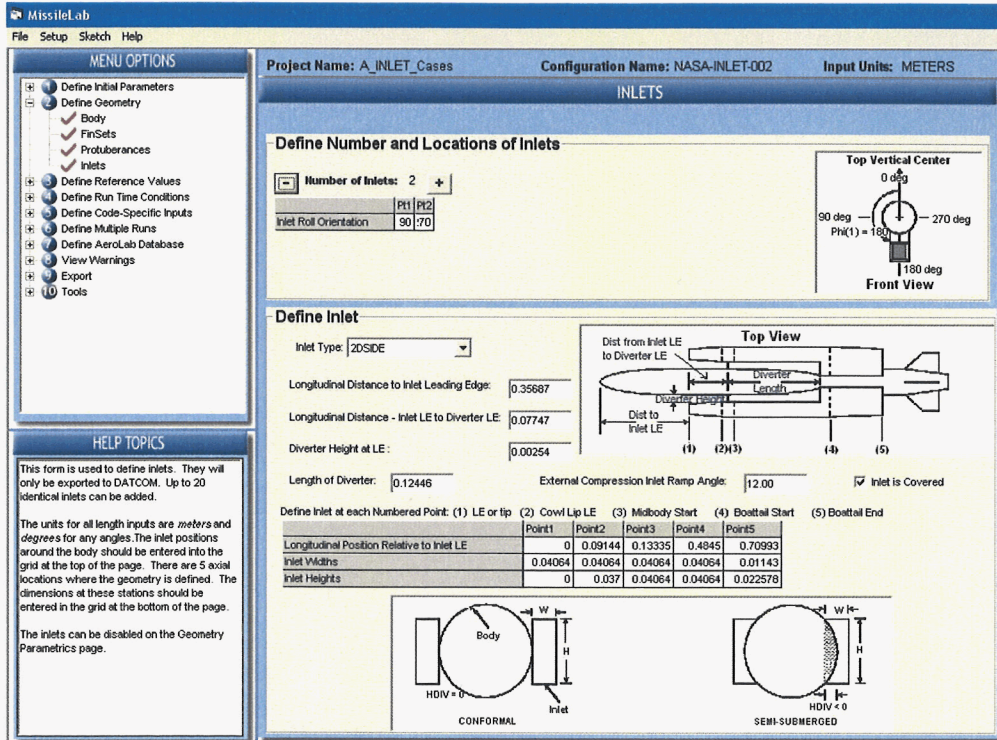
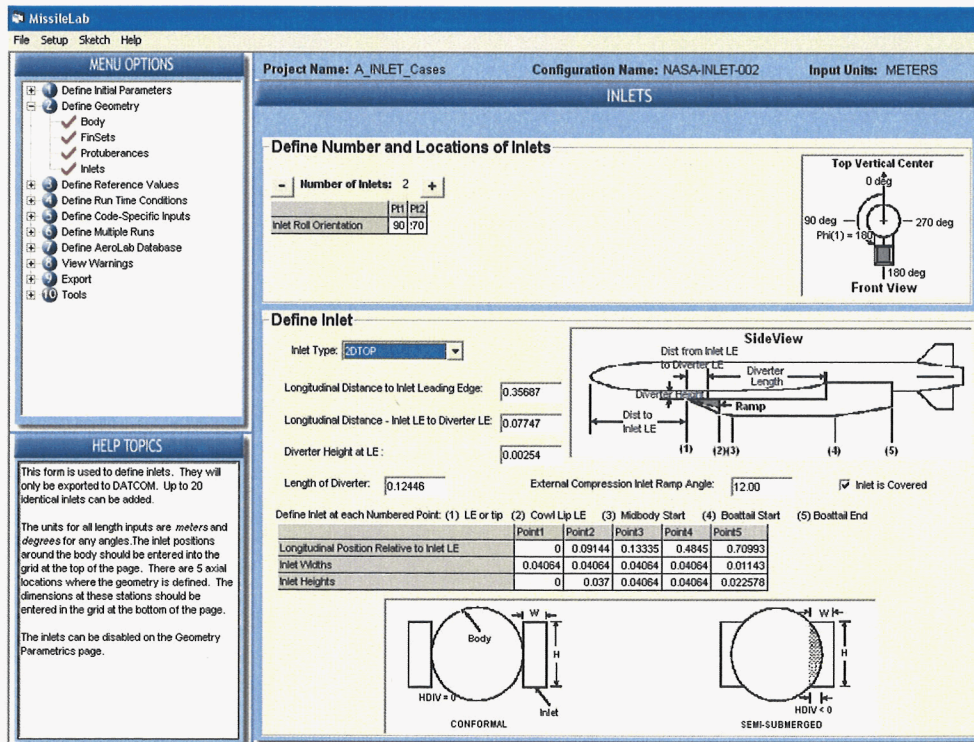

Figure 25. Protuberance Orientation Screen

Inlets Screen: The inlet geometry input screen is presented in Figure 26. Inlet geometry as specified on this screen is specific to Missile DATCOM and the 3-D model geometry functions, and has no bearing on the input deck generated for APxx, MISL3, MISDL, or HASC. Inlets are not drawn in the 2-D sketches, but are displayed in the 3-D sketches. Inlet geometry can be turned on and off under the “[Geometry Parametrics](#)” screen which will be discussed further in Section III.D.4.



(a)



(b)

Figure 26. Inlet Geometry Input Screen

3. Define Reference Values Screens

Body Reference Screen: Figure 27 presents the Body Reference screen. Here the user is queried to enter the characteristic reference length, area, moment reference point, and boundary-layer transition information. For user convenience, a calculator command button is provided that automatically calculates the reference length and reference area based on the maximum body cross-section. If other reference values are desired (e.g. wing area, area of a non-cylindrical body cross-section, and so on), then the user simply enters the desired value in the text box fields.

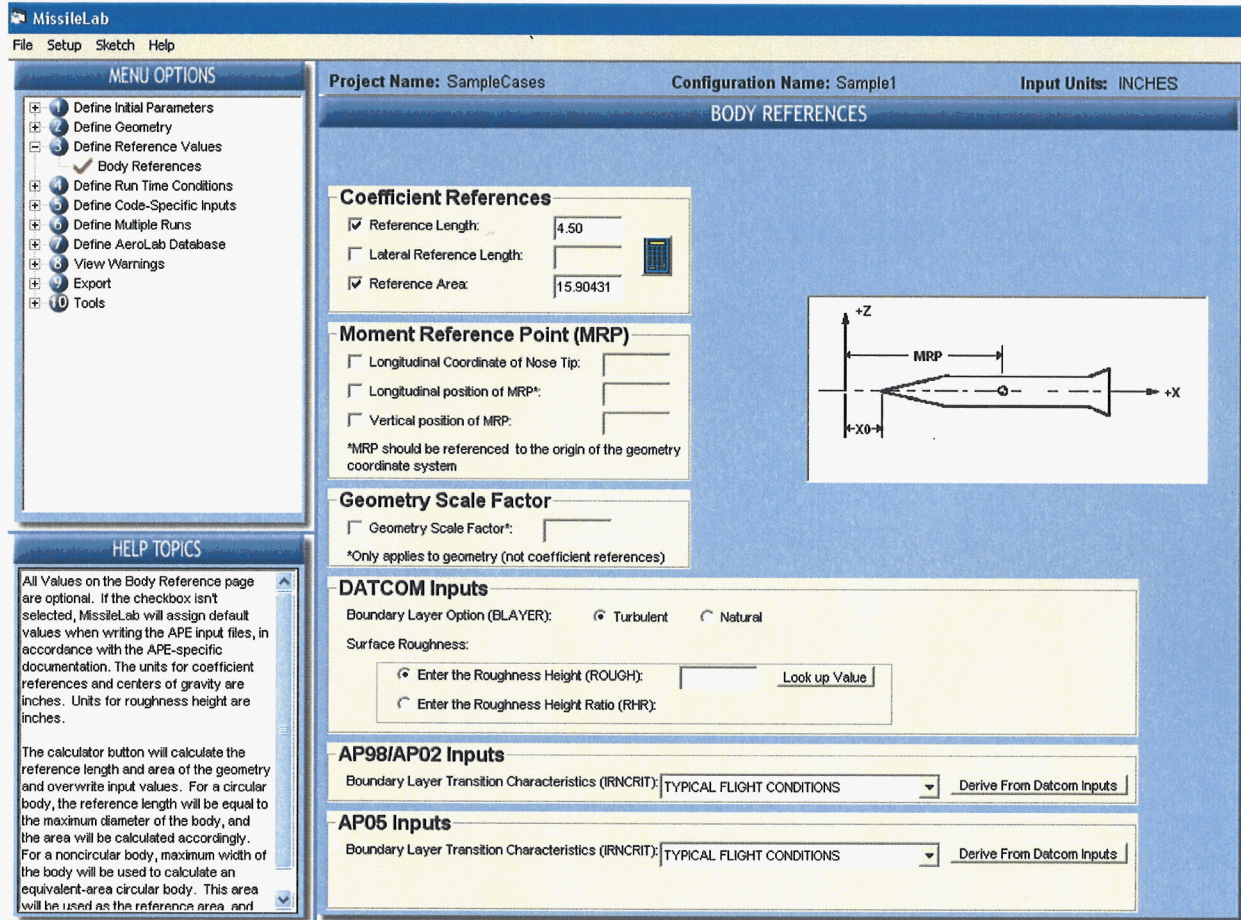

Figure 27. Reference Screen

Change Note: Calculator button functionality.

The calculator button in previous versions of MissileLab calculated the reference area of a circle with a diameter EQUAL to the reference length. MissileLab version 7 calculates the reference area of the maximum body cross-section of the input body shape and sets the reference length to be the diameter of a circle with equivalent area.

Notice the code-specific inputs on the Body Reference page. The user must define the DATCOM boundary layer option and the APxx boundary layer transition characteristics. In this example, the user has the option of allowing MissileLab to derive the APxx boundary layer transition based on the specified DATCOM inputs, or alternatively the user may select the desired AP boundary layer transition value via the pull-down selection box.

Notice that there is a “Look-up Value” button to the right of the roughness value entry field. Selecting this button opens the screen shown in Figure 28. Here the user may select the surface that he or she desires and click “OK”. When the screen closes, the selected value is automatically entered into the roughness value field. Similarly, if the user had selected the roughness height ratio option and then selected the look-up value button, the screen shown in Figure 29 would have appeared.

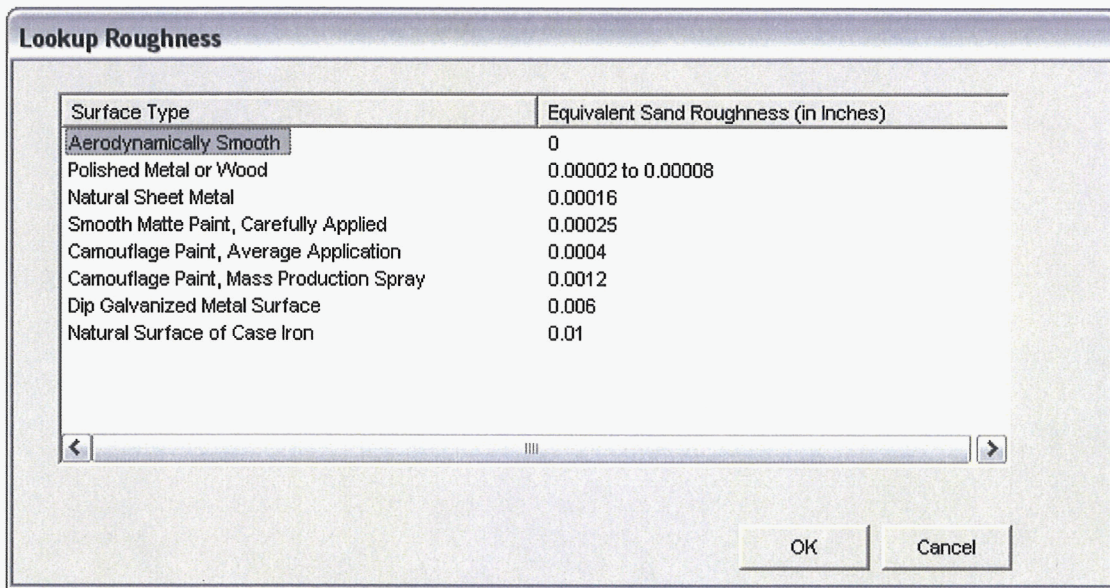

Figure 28. Roughness Height Selection Screen

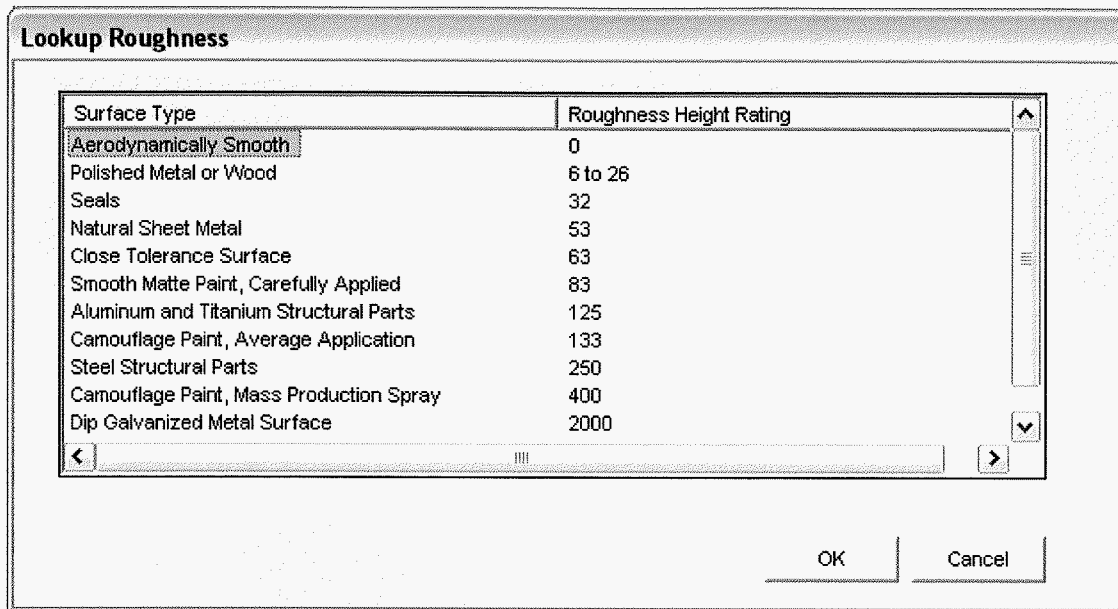

Figure 29. Roughness Height Ratio Selection Screen

4. Define Run Time Conditions Screens

The “Run Time Conditions” screens control body-build-up runs, flight conditions such as Mach number and Angle-of-Attack (AOA), fin deflections, power-on/power-off base drag effects, and inlet-drag effects.

Geometry Parametrics Screen: Control over APE geometry files is provided via the Geometry Parametrics screen shown in Figure 30 (a), (b), and (c). This screen allows the user to turn on/off fins to conduct body build-up analysis; in the case of Missile DATCOM inlets and protuberances may be turned on or off; and in the case of APxx the body may be turned off to allow for wing-alone calculations.

In addition to turning specific fin sets on and off, the user should specify if the given fin set is to be used for control. As Missile DATCOM, NEAR MISL3, MISDL, and HASC allow for dual control, all fins sets may be specified as “Used for Control” for these codes. However, as APxx does not allow for dual control, selecting a given fin set for control automatically sets the other fin set for “Used for Stability”. If fin deflections are to be entered in the “Deflections/Trim” screen that will be discussed later in this section, then one of the fin sets must be selected for control.

Figure 30.b presents the MISL3 Geometry Parametrics Page. In addition to enabling/disabling body and finsets, the user defines vortex shedding information for each finset enabled. At the bottom of the page is an option for enabling User-Specified Body Loads. If this is selected, the loads should be entered on the MISL3 Body Loads page (discussed later).

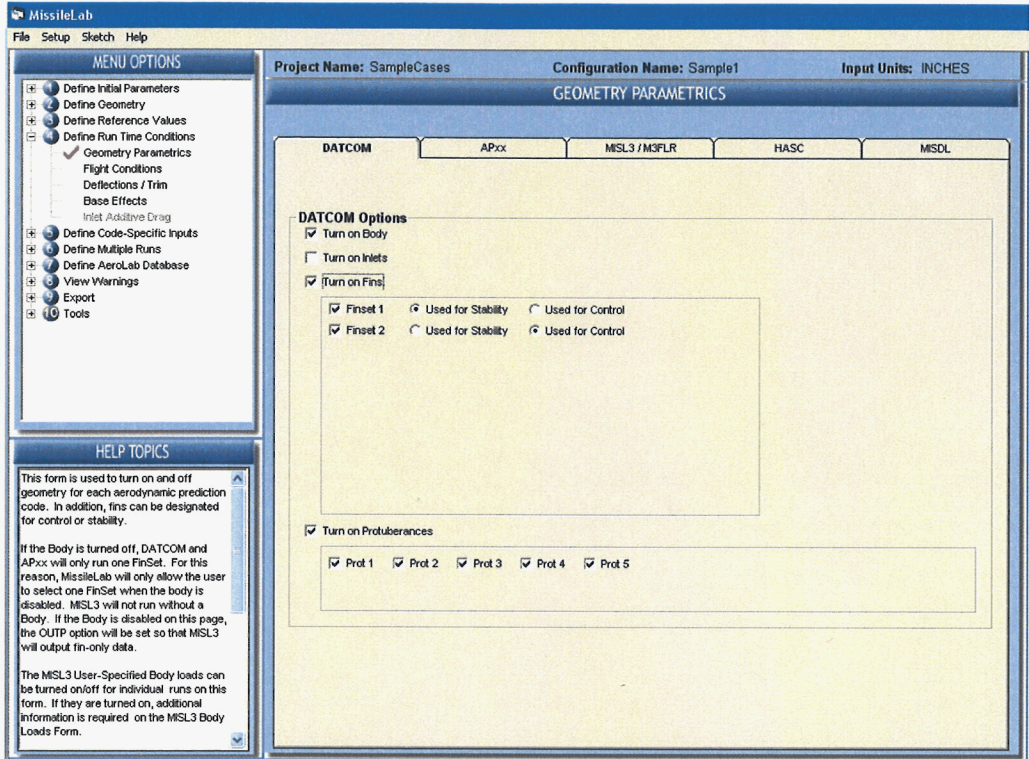

(a)

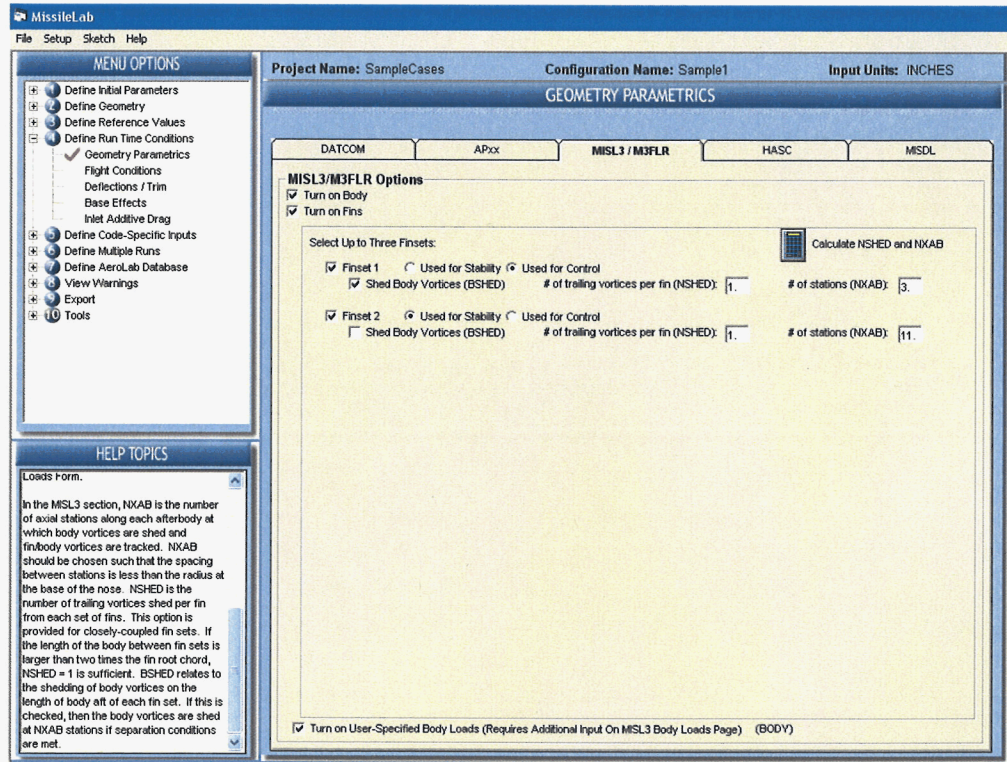

(b)

Figure 30. Geometry Parametrics Screen

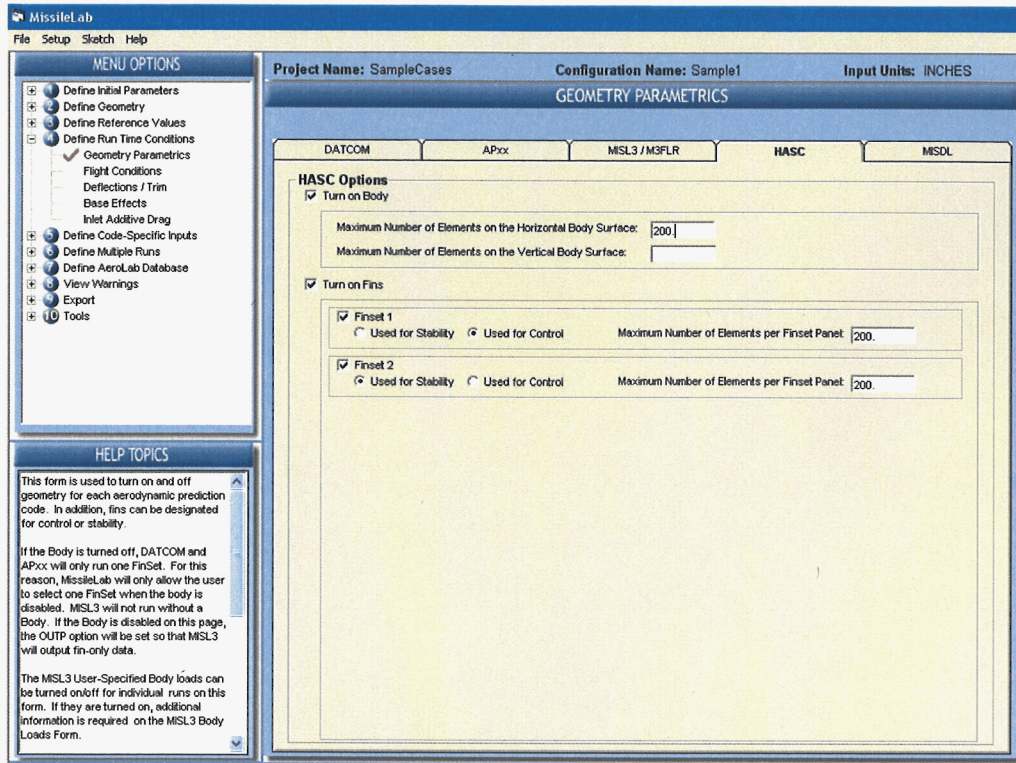

(c)

Figure 30. Geometry Parametrics Screen (Concluded)

The HASC Geometry Parametrics page is shown in Figure 30.c. The user must enable/disable the body and finsets. In addition, the maximum number of elements to be used for the body and finsets must be defined.

Flight Conditions Screen: Flight conditions, such as Mach number, altitude, AOA, and roll angle are entered into MissileLab using the flight conditions input screen shown in Figure 31. The user has several ways to enter the desired velocity conditions as shown in Table 5. As APxx, MISL3, and HASC require Mach number and Reynolds number as the input, these values are calculated by MissileLab using an atmosphere model if anything other than Mach and Reynolds number are entered.

Up to 20 Mach numbers and up to 20 AOA may be entered for a given case. Also the user may specify a Side-slip angle or an Aerodynamic roll angle. The Side-slip or roll angle is exported to DATCOM, MISL3, and MISDL but is not exported to APxx as AP only supports roll angles of 0 and 45 degrees. If Side-slip is defined, it will be exported to HASC. Roll angle is not exported to HASC. If the user wishes to export $\phi=45$ degrees data from APxx, then this is specified via the APxx specific pull-down box on the Flight Conditions screen.

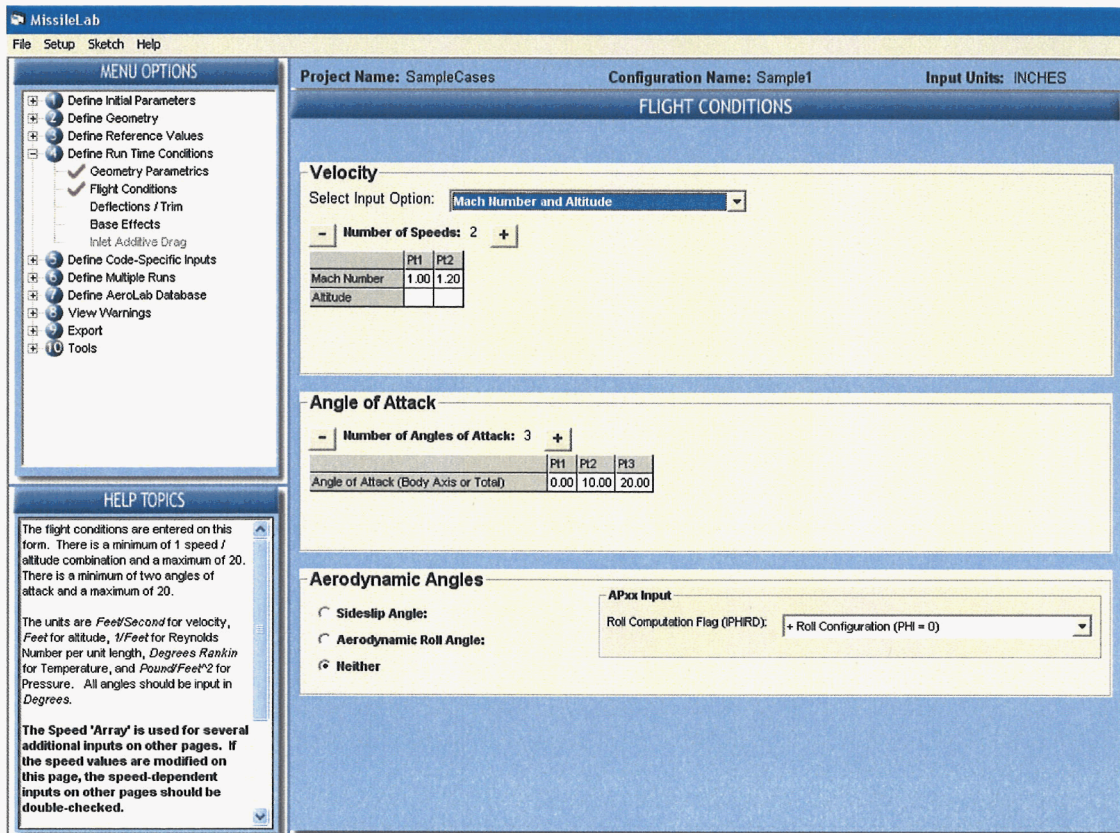

Figure 31. Flight Conditions Input Screen

Table 5. Flight Conditions Screen Pull-Down Fields

MissileLab	DATCOM	APxx, MISL3, HASC	MISDL
Mach & Altitude	As entered	Mach & Rn calculated using a standard Atmosphere model	As entered
Mach & Rn	As entered	As entered	As entered
Mach, Pressure & Temperature	As entered	Mach & Rn calculated using a standard Atmosphere model	Mach & Rn calculated using a standard Atmosphere model
Velocity, Altitude	As entered	Mach & Rn calculated using a standard Atmosphere model	Mach & Rn calculated using a standard Atmosphere model
Velocity, Pressure & Temperature	As entered	Mach & Rn calculated using a standard Atmosphere model	Mach & Rn calculated using a standard Atmosphere model

Deflections / Trim Screen: Canard/Wing/Fin control deflection inputs are specified in the “Deflections / Trim” screen presented in Figure 32. As noted previously, for these fields to be active the user must have selected a finset for control on the “Geometry Parametrics” screen (see Fig. 30). To simplify the “Deflections / Trim” page, the “DATCOM / MISL3 / MISDL / HASC” section will use the finsets designated for control from the DATCOM option to enable finsets on the Geometry Parametrics page. If the deflections are being exported to an APE that does not have the same finset(s) designated for control, the deflections will not be exported. Always check the Geometry Parametrics page to ensure that the correct finsets are designated for control. Notice also the two styles for inputting control deflections. The first is per panel as used for DATCOM, NEAR MISL3, MISDL, and HASC, and the second is for an equivalent fin deflection angle as used in the APxx codes.

MissileLab and DATCOM define positive fin panel deflection angles such that positive fin deflection angles produce a negative (or counterclockwise) rolling moment.

NEAR MISL3 and MISDL define positive fin panel deflections so that they produce a positive normal force. Therefore, when MissileLab is writing these input files, MissileLab will change the SIGN of the fins on the "left side" (i.e. $180 < \phi < 360$) of the missile to conform to the NEAR MISL3 and MISDL fin deflection standard. Deflections in HASC also have the SIGN changed on the “left side” of the missile. If trailing edge flaps are defined, the fin deflections will be applied to the flap in DATCOM. For MISDL, the fin and the flap can be deflected independently. The MISDL flap deflections should be entered in the MissileLab sign convention.

APxx expects an equivalent fin deflection angle that will produce an in-plane pitch maneuver. **Positive equivalent fin deflection angles in AP produce a positive normal force increment at zero AOA for both canard controlled and tail controlled configurations.** Therefore, assuming that canards are forward of the MRP and the tails are aft of the MRP, then positive canard deflections in AP produce positive (nose up) pitching moments, and positive tail deflections in AP produce negative (nose down) pitching moments.

The “Run Trimmed Flight” option is used to obtain trim conditions. If this option is selected, the finset number to be used is input as well as maximum and minimum deflections and the designation of which panels in the finset are used. Trimmed flight only applies to DATCOM and MISL3.

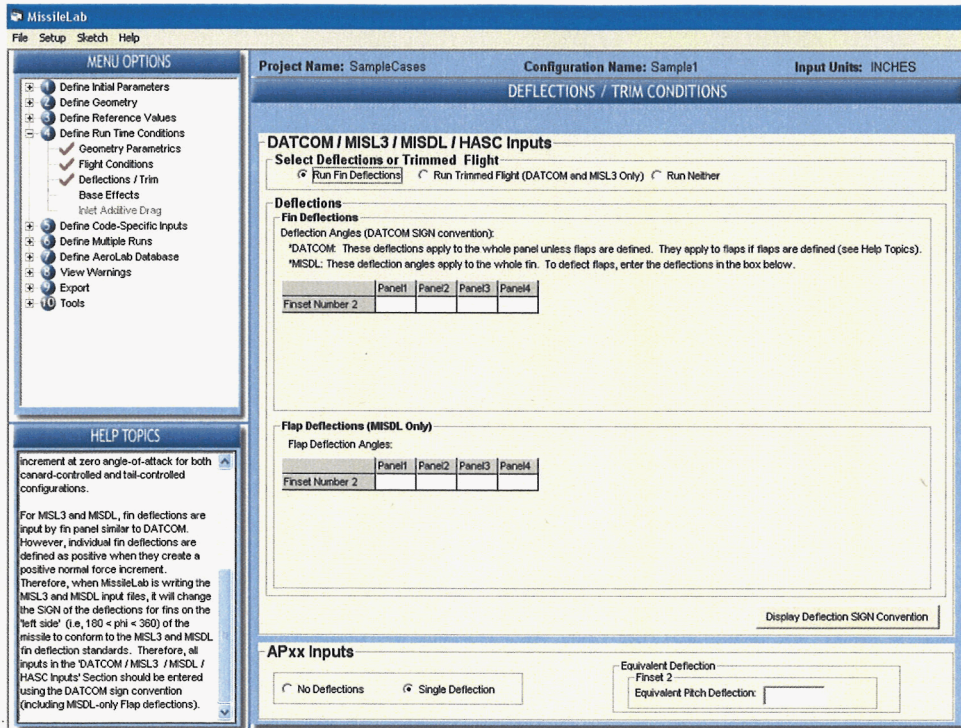

Figure 32. Control Deflections Input Screen

Base Effects Screen: Base drag effect information is entered via the panel presented in Figure 33.

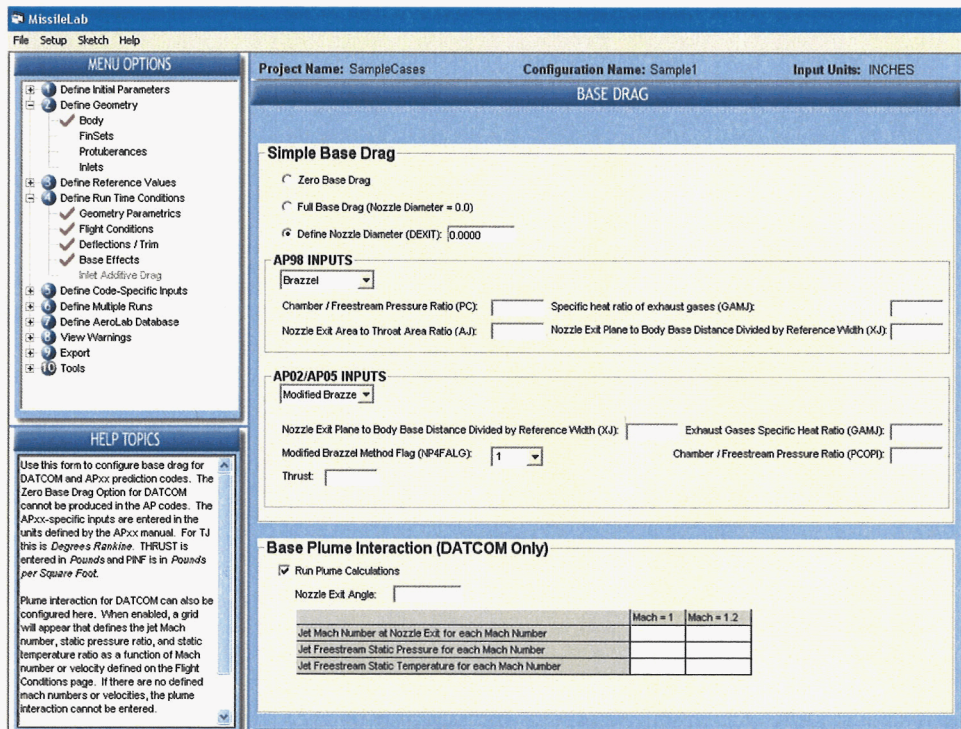

Figure 33. Power-on/Power-off Base Drag Input Screen

Inlet Additive Drag Screen: Inlet Additive Drag information is entered via the panel presented in Figure 34. This option will be disabled (as shown in Fig. 33) if no inlets have been defined.

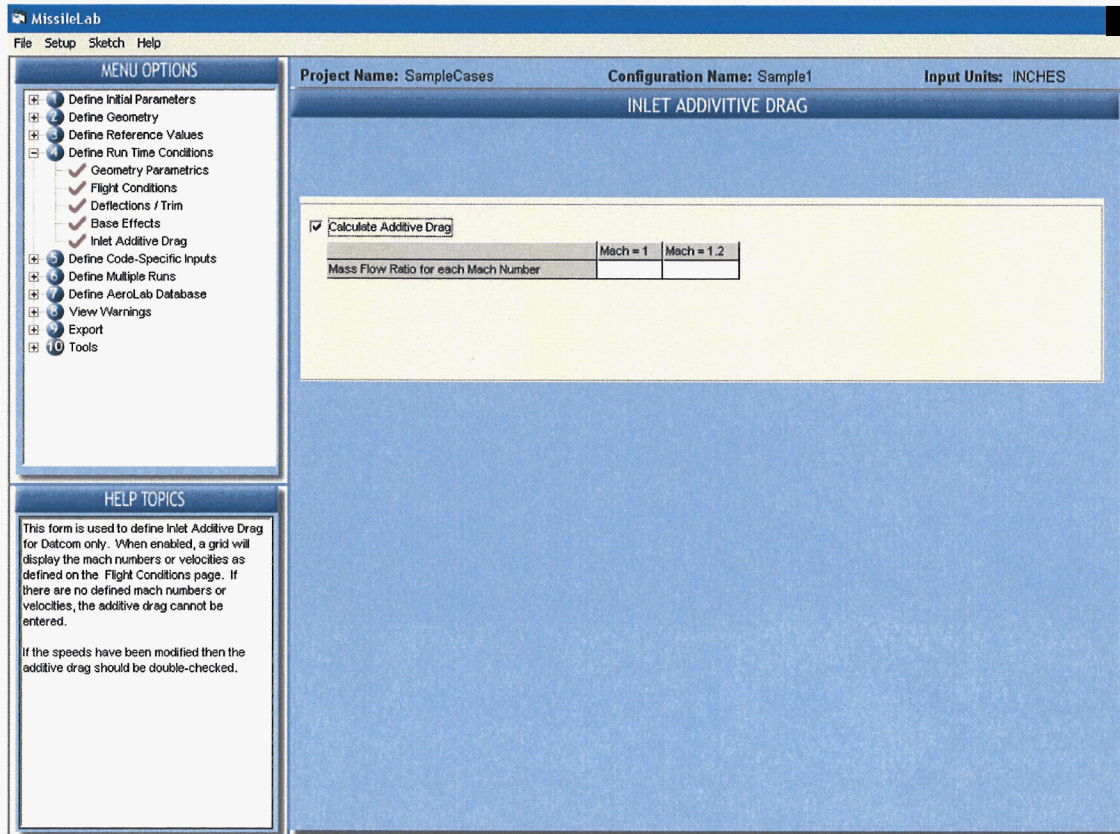

Figure 34. Inlet Additive Drag Input Screen

5. Code Specific Inputs Screens

DATCOM-Specific Inputs Screens: The “**DATCOM-Specific Inputs**” screens control various DATCOM cards such as SOSE, HYPERS, PART, BUILD, DAMP, SPIN, and so on. As these control cards should be familiar to any experienced DATCOM user, nothing else will be said about them here other than to show the various screens (see Figs. 35 through 37). If additional information is required, please refer to the DATCOM user’s manual.

The screen shown in Figure 37 provides controls for “WRITING” and “DUMPING” array data from older versions of Missile DATCOM (version 9/02 and earlier). This functionality has been deleted from DATCOM 1/06 and later versions of the code.

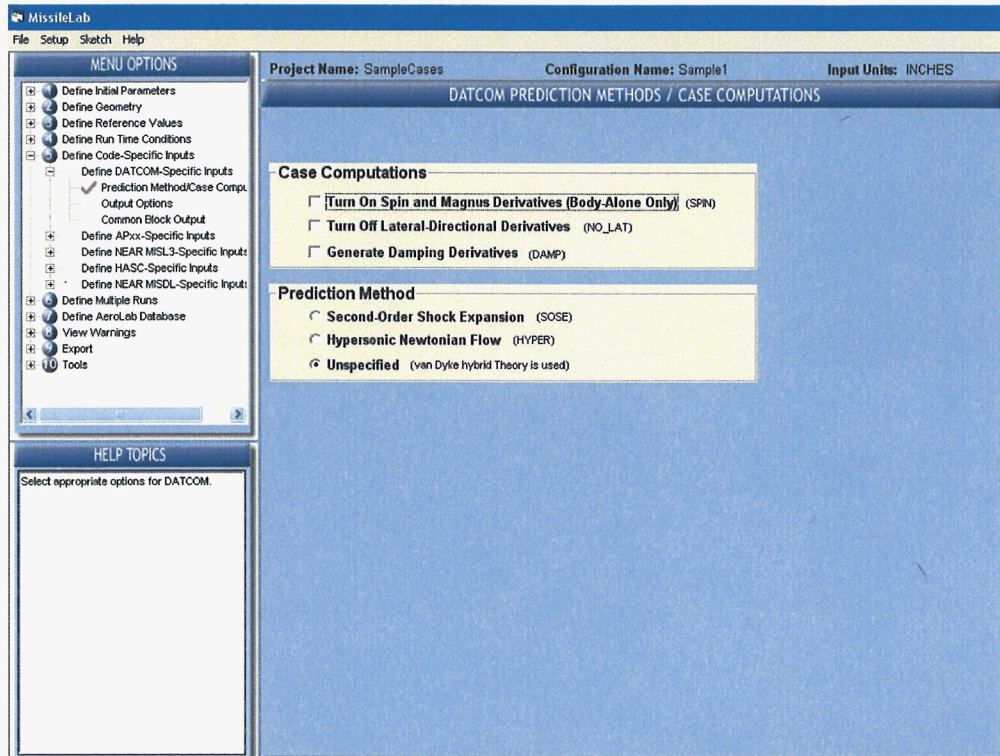

Figure 35. DATCOM Prediction Methods Screen

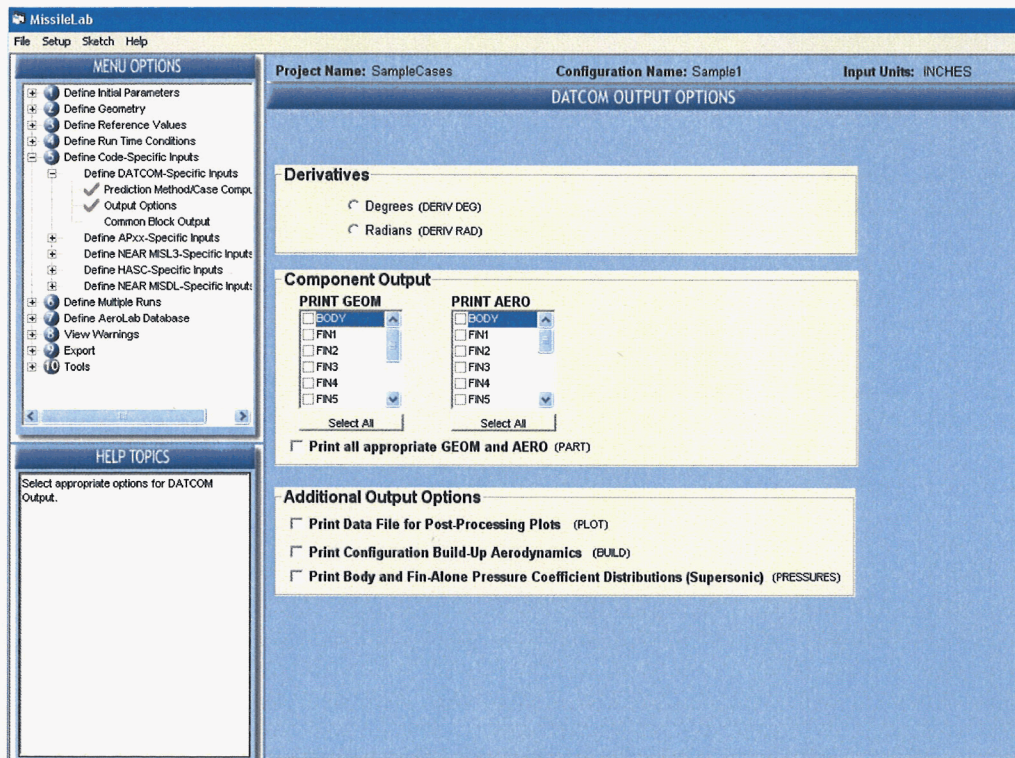

Figure 36. DATCOM Output Options Screen

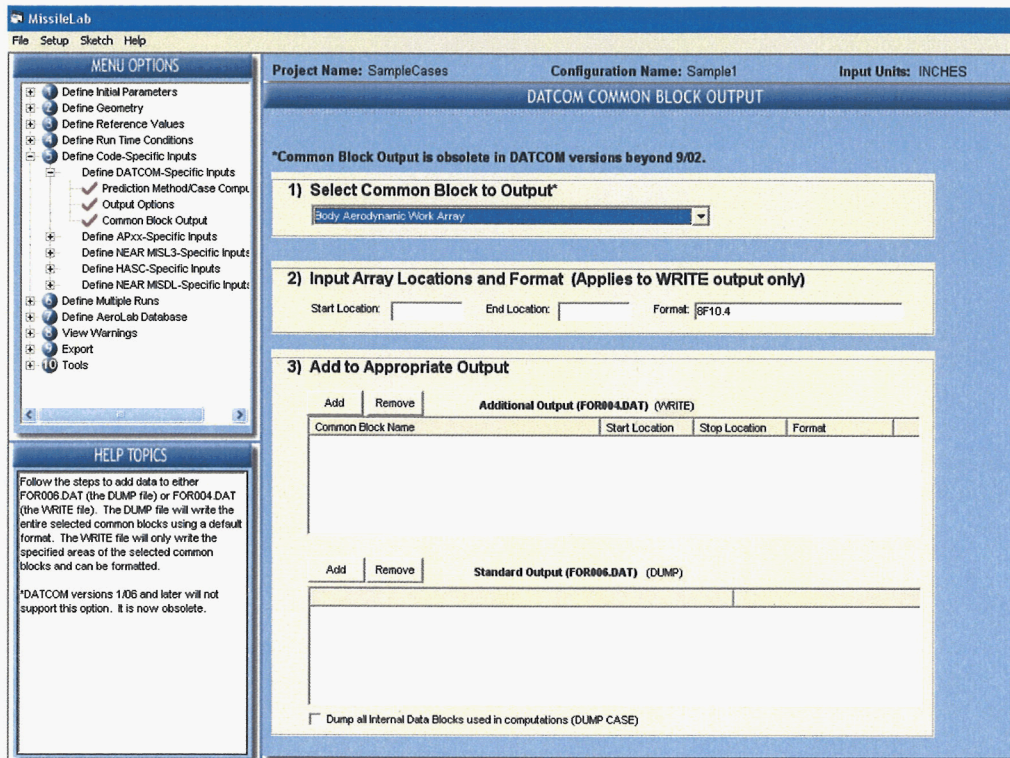

Figure 37. DATCOM Common Block Output Screen

APxx-Specific Inputs Screens: The “[APxx-Specific Inputs](#)” screens control various AP-xx control cards such as ISPIN, IPRINT, ALIMIT, ALIMIS, smoothing, and so on. As these control cards should be familiar to any experienced AP user, nothing else will be said about them here other than to show the screen in Figure 38. If additional information is required, please refer to the AP user’s manual.

The AP05 protuberance screen is presented in Figure 39. Again, the user is referred to the AP05 manual for more information. However, there is one subtle point that is not covered in the AP05 manual that will be briefly discussed below.

MissileLab does NOT automatically populate the Mach array for the AP05 protuberance screen, as the inputs do not have to correspond to the Mach numbers input under the flight conditions input screen.

AP05 allows the user to input in any number of Mach numbers and corresponding protuberance data. AP05 (i.e. AP05FOR.EXE) then interpolates the protuberance data given the input flight condition Mach number. For flight condition Mach numbers that are outside the input protuberance Mach numbers, AP uses the nearest set of protuberance data. For example, suppose you put in perturbation inputs at Mach 2.3 and 4.6 as was done in the AP05 User’s Guide. You then ran Mach numbers of 1.0, 2.3, 3.5, 4.6, and 7.0. AP05 would use the protuberance data defined for Mach 2.3 for flight conditions of Mach 1.0 and 2.3. For the flight condition of 3.5, AP05 would interpolate between the 2.3 and 4.6 protuberance data, and for the flight conditions of 4.6 and 7.0, AP05 would use the protuberance data defined at Mach 4.6.

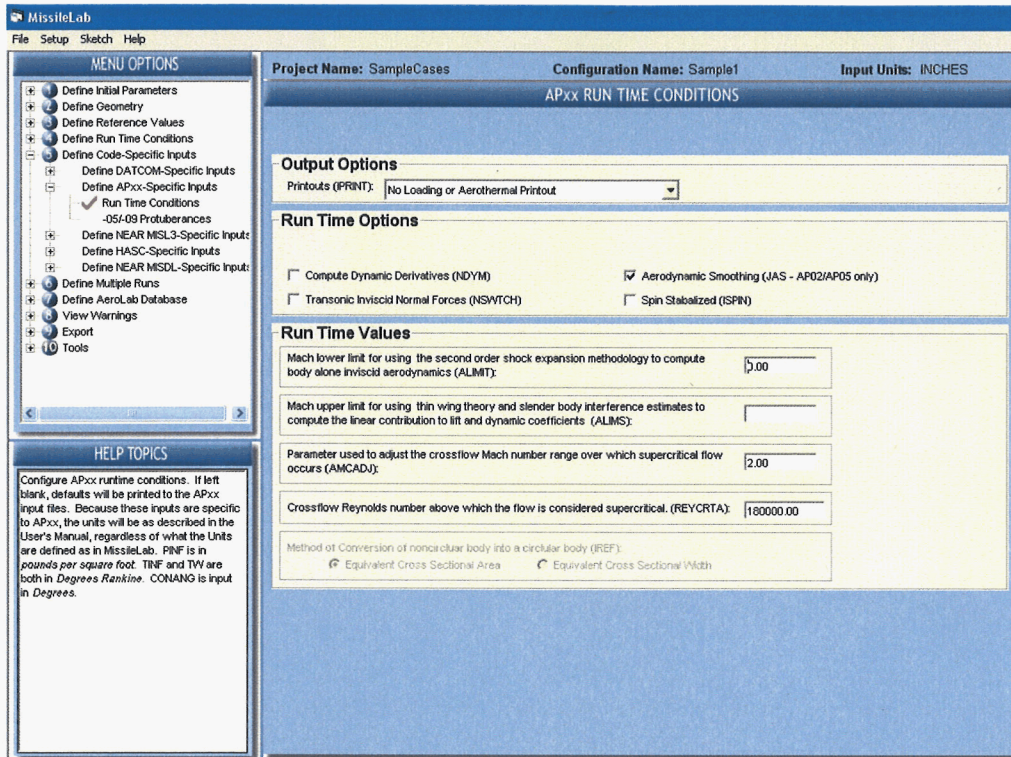

Figure 38. APxx Run Time Conditions Screen

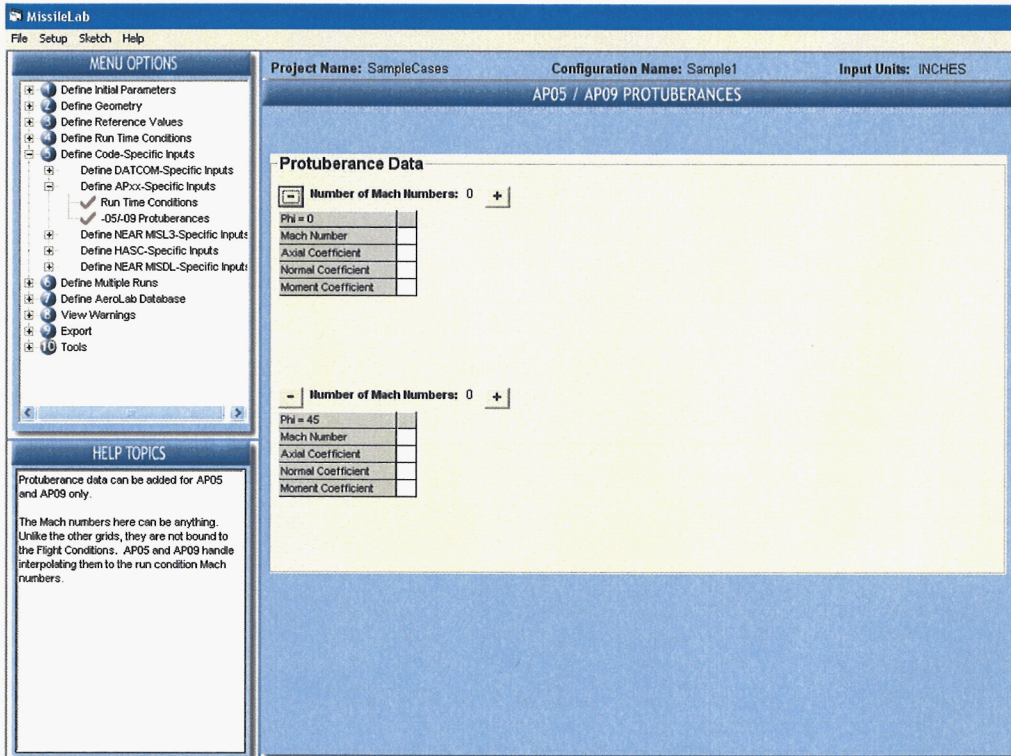

Figure 39. AP05 Protuberance Input Screen

NEAR MISL3 -Specific Inputs Screens: The “NEAR MISL3-Specific Inputs” screens presented in Figures 40 and 41 control various NEAR MISL3 control cards such as body rotation rates, body loads, output options, and so on. These control cards should be familiar to any experienced NEAR MISL3 user. If additional information is required, please refer to the NEAR MISL3 user’s manual.

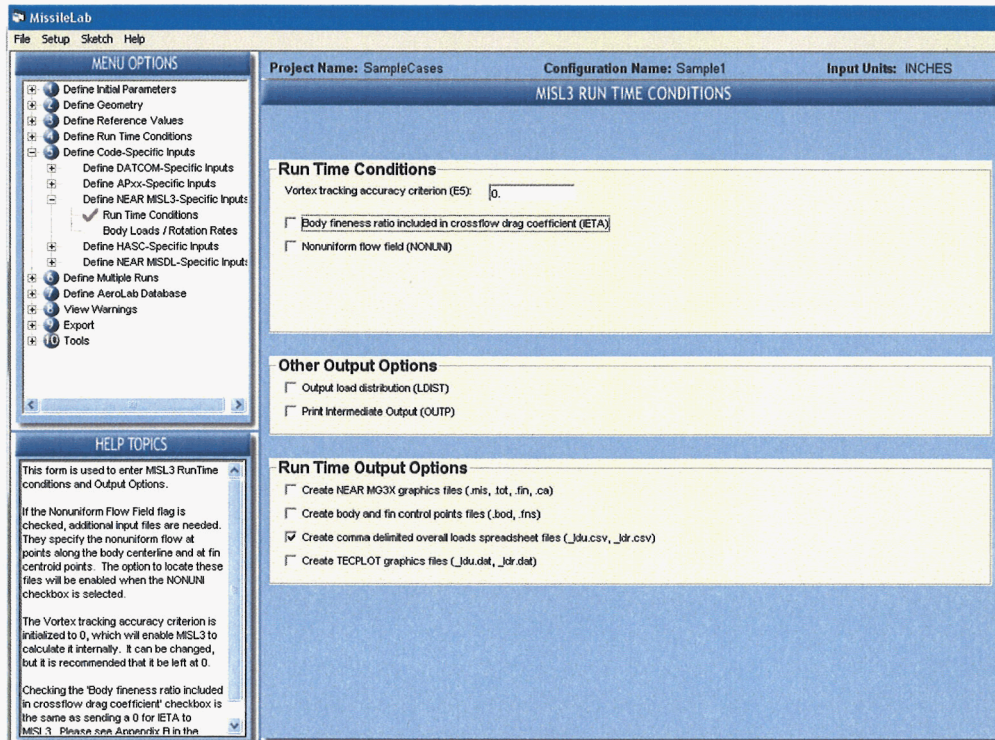

Figure 40. NEAR MISL3 Run Time Input Screen

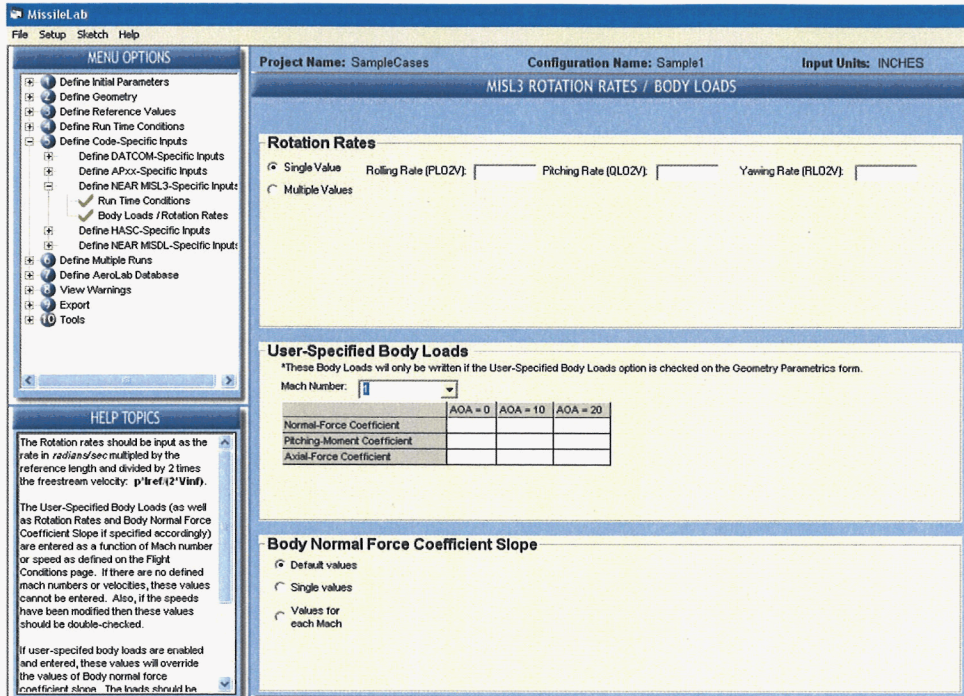

Figure 41. NEAR MISL3 Body Loads Input Screen

HASC-Specific Inputs Screens: The “HASC-Specific Inputs” screen presented in Figure 42 describes various run-time conditions for HASC. These include vortex spacing, ground effects, output options, and rotation rates. Please refer to the HASC user’s manual if additional information is required.

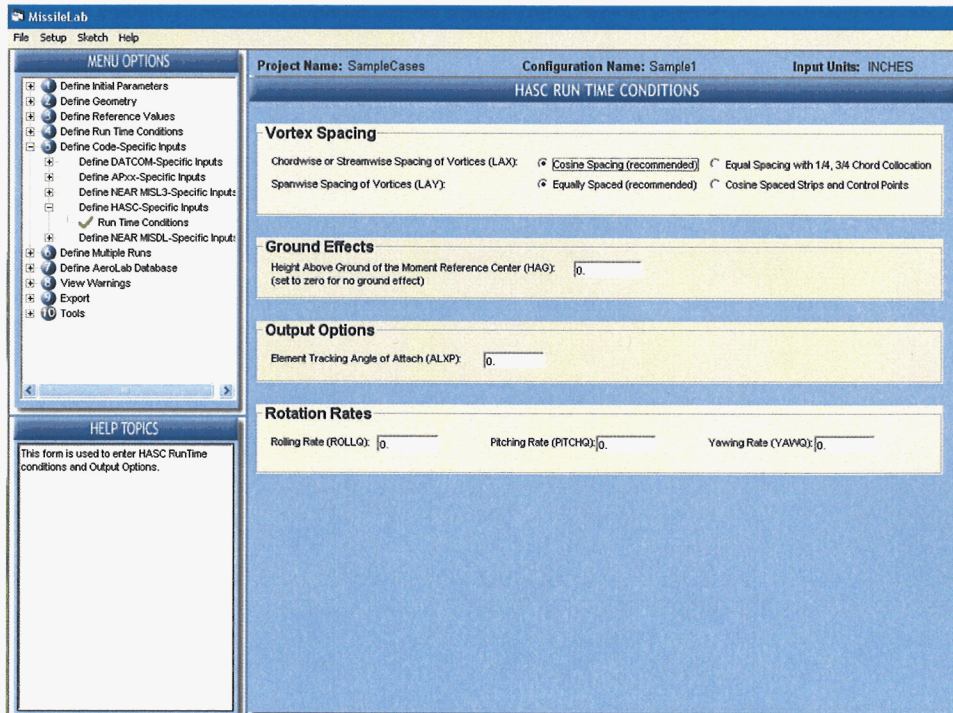

Figure 42. HASC Run-Time Input Screen

MISDL-Specific Inputs Screens: The “MISDL-Specific Inputs” screens presented in Figures 43 and 44 control various MISDL inputs such as additional fin information, run-time conditions, and rotation rates. A few inputs are discussed here. Please refer to the MISDL user’s manual if additional information is required. Note that the parameters that define the panel layout on the “MISDL Fin Parameters” page are not given default values. It is critical that these values are entered accurately. MissileLab gives suggested values (by clicking on the “Show Suggested Values” button), but it is the user’s responsibility to verify these values and enter the appropriate panel layout information.

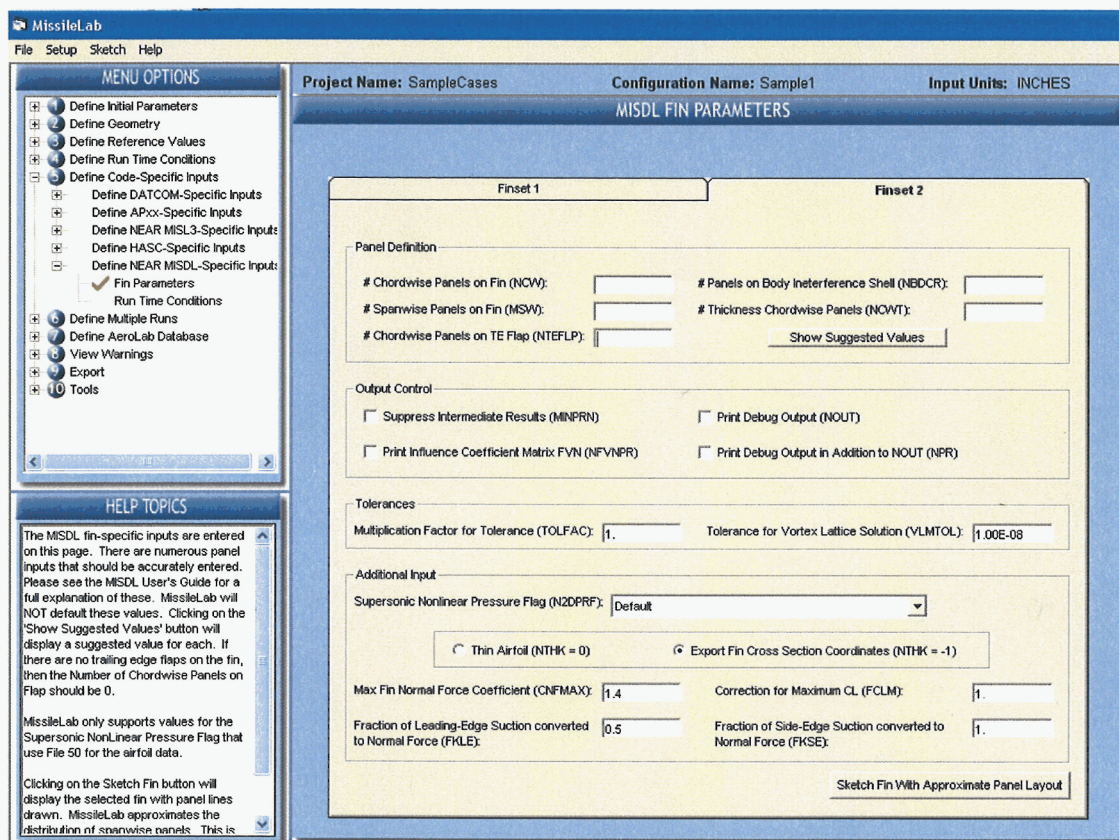

Figure 43. MISDL Fin Parameters Input Screen

On the Run-Time Conditions page, there are four inputs that do not correspond directly to MISDL inputs. These inputs are used for an Arbitrary Body only. The first two are “Number of Radial Slices Around Body Cross-Section” and “Number of Corner Slices”. These two inputs will be used to determine the MISDL variable “NR”. The “Number of Corner Slices” only applies to a non-circular, non-elliptical cross-section that has a corner radius defined. It defines how many “slices” will be generated at EACH corner. The number of radial slices should INCLUDE the number of corner slices. Also, this number is defined around the ENTIRE cross-section (not just one half, as NR is defined). The actual number of slices may be internally adjusted (slightly) by MissileLab if necessary. The maximum number of slices is 60.

The “Cylindrical/Conical Section Diameter Multiplier” is used to determine the spacing of the cross-sections. For example, a value of 1.0 for a body with diameter .5 units would produce a cross-section output every .5 units. This only applies to conical or cylindrical segments aft of the nose. The nose segment is always broken into 31 cross-sections to provide an accurate geometry of the nose types. An Ogive aft segment would also use 31 sections.

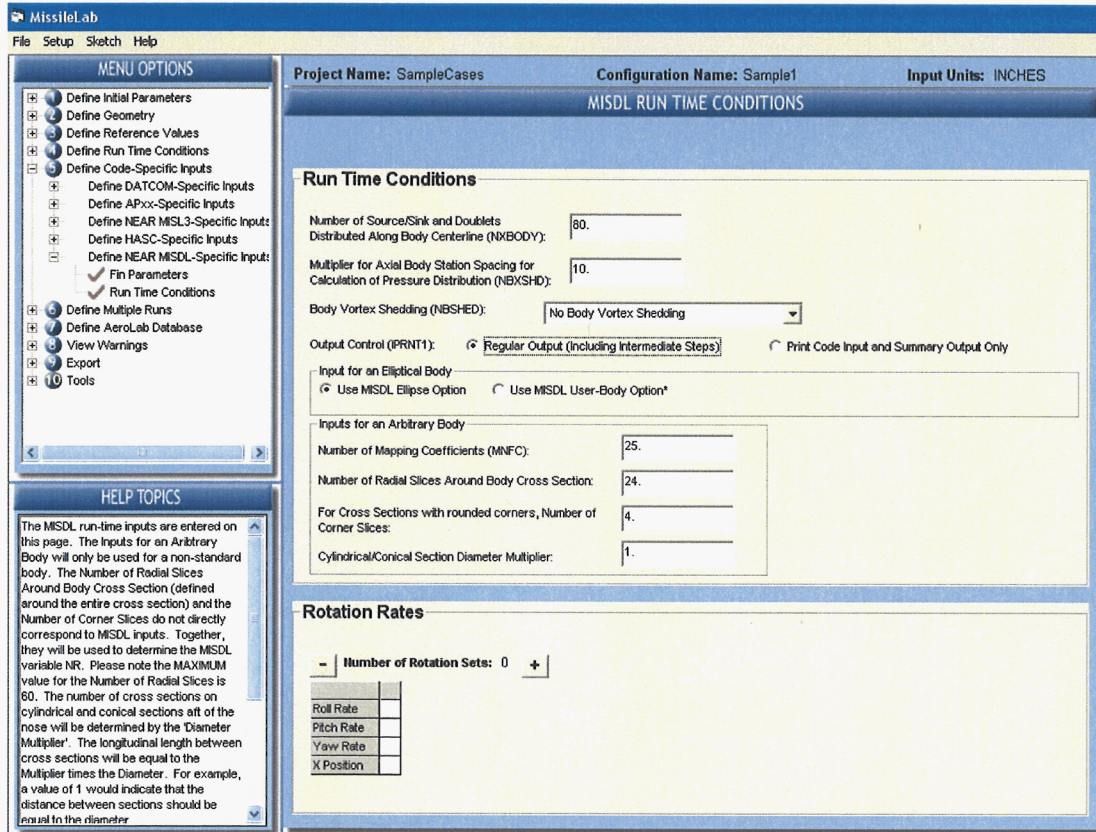

Figure 44. MISDL Run-Time Input Screen

6. Define Multiple Runs Screen

Run Manager Screen: The “Multiple Runs” case manager screen is presented in Figure 45. In designing this screen and functionality, the question that must be addressed is: “what do we allow the user to change for a specific project configuration file?” Using the guidelines set out in Section I, it was decided that for a given configuration, the user should have control over (1) body build-up, (2) flight conditions, (3) control deflections, (4) power-on/power-off base drag, and (5) inlet drag. If, for example, the MissileLab user needs to change the wing geometry, this should be done by making a copy of the MissileLab geometry file (*.MNL) and then modifying the wing in that file. If, however, the MissileLab user wants to make various control deflection runs (for the given airframe geometry), then that will be handled by the case manager as shown in Figure 45

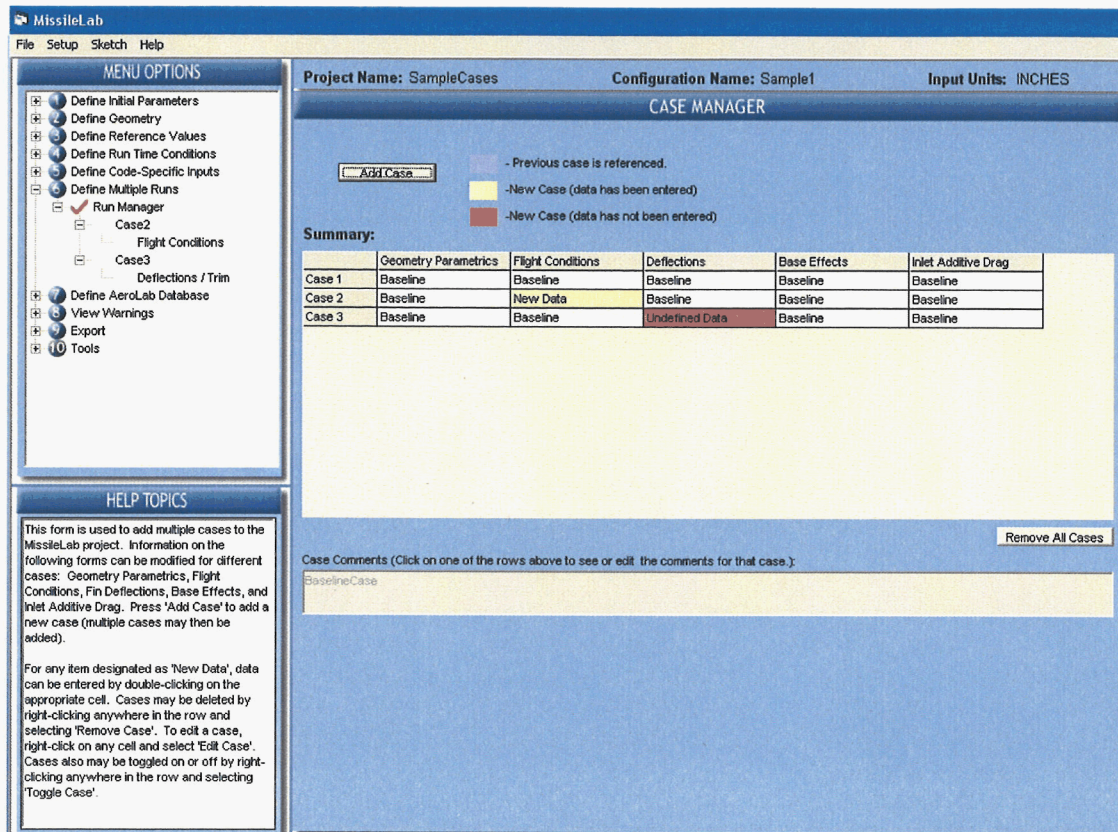

Figure 45. Multiple Run Case Manager Screen

Once the baseline geometry is defined, the user may add multiple cases (by clicking on the “Add Case” button), select what will change for that case, and then enter the new data. The data for the new case will be initialized with the data from the baseline case. To enter the new data, the user can “double-click” on the appropriate “Undefined Data” cell in the grid (likewise “double-clicking” on a “New Data” cell will allow editing of the data). In addition, the cases will be added to the Menu Options tree under Run Manager (as seen in Fig. 45), and selecting them works just like clicking on any other “Menu Option” item. When additional cases are defined, MissileLab LOCKS the baseline geometry to prevent the user from inadvertently modifying the baseline data. When this occurs a red “KEY” command button appears in the upper left of each screen. Clicking on this button will unlock the screen and allow the user to modify the baseline configuration data.

7. Define AeroLab Database Parameters Screen

Configure AeroLab Database Parameters Screen: To facilitate comparison of predicted data to wind tunnel test results, functionality has been incorporated to have MissileLab automatically generate an AeroLab database. The AeroLab database interface screen is presented in Figure 46. On this screen, the user must specify the six-character alphanumeric database name, a configuration name, and “database run numbers”.

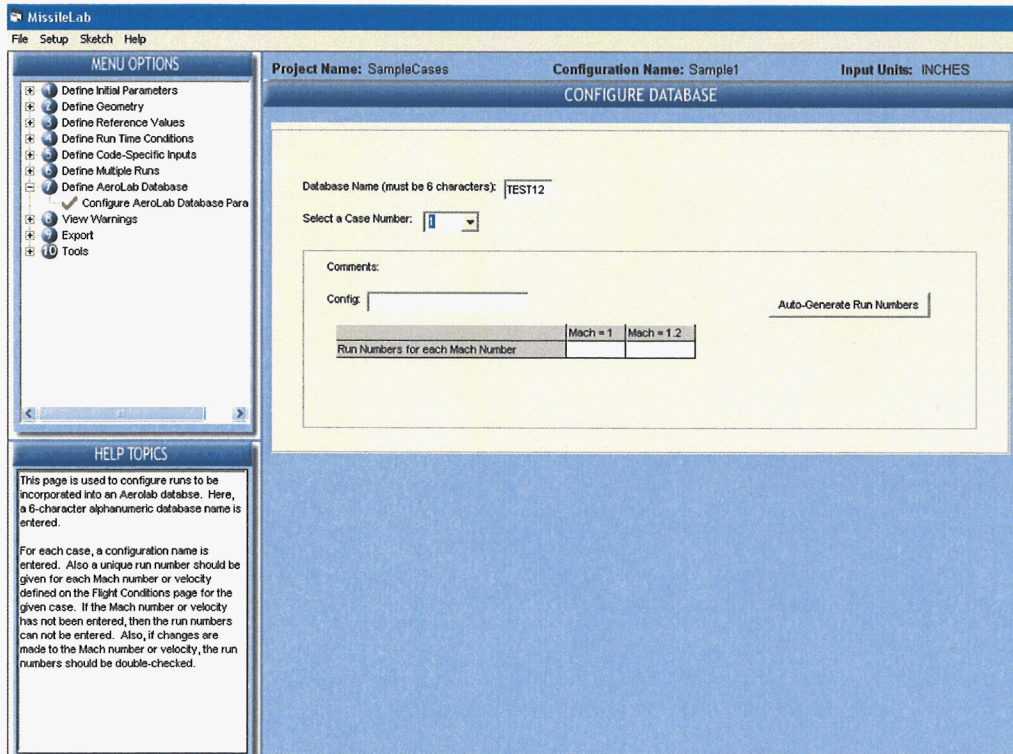

Figure 46. AeroLab Database Management Screen

8. View Warnings Screens

An attempt has been made to identify as many “problems” as possible before the specific APE input files are generated. MissileLab generates two types of warnings: **CRITICAL ERROR** and **NONCRITICAL WARNING**. If MissileLab identifies a critical error for a given APE, that code is disabled and cannot be selected on the “Export Data” screen. MissileLab will allow the user to run APEs with noncritical warnings, but the user should review all warnings.

For example, some APEs allow for eight fins, while others do not. So if the airframe geometry is defined with eight wings/fins, then MissileLab identifies this as a **CRITICAL ERROR** for the codes that will not run 8-fin panels. An example of a noncritical warning would be if the user defined an airfoil section with a NACA airfoil. APxx does not have NACA airfoil capability, so MissileLab substitutes a bi-convex fin section when it writes the APxx input file.

Figures 47 through 51 present sample warning pages for a given airframe geometry. A summary list of the errors and warnings that MissileLab identifies is accessible under the Help menu item and an example of this screen is presented in Figure 52.

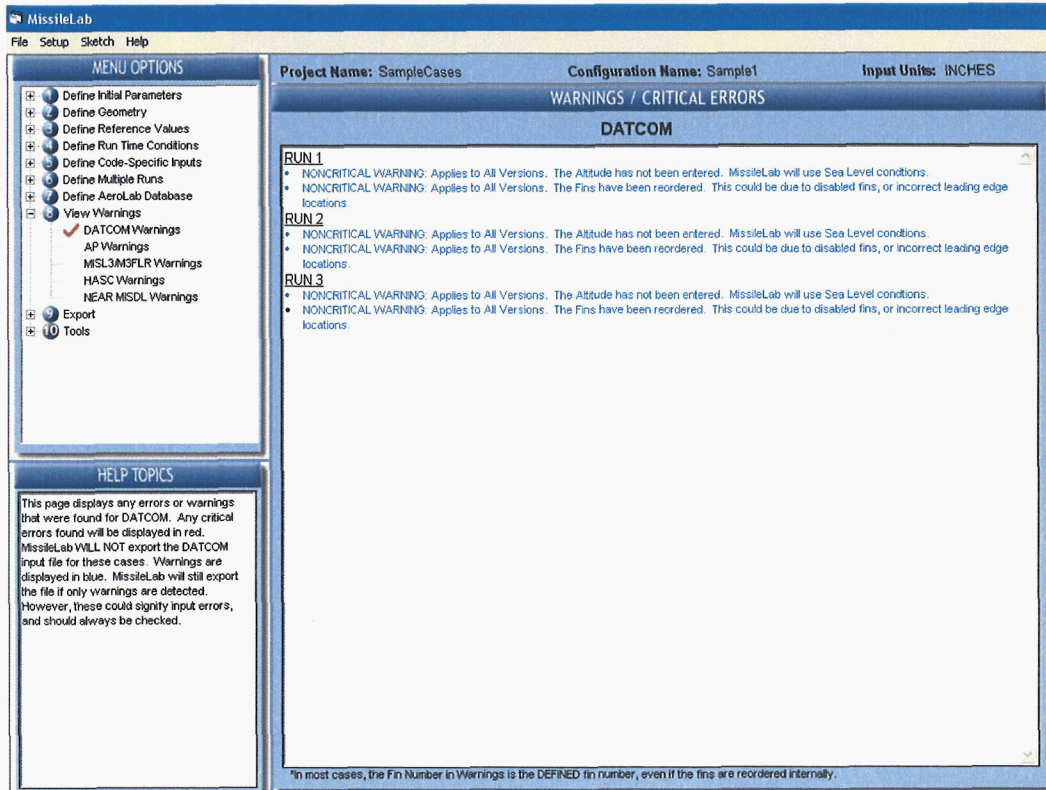

Figure 47. DATCOM Warning Screen

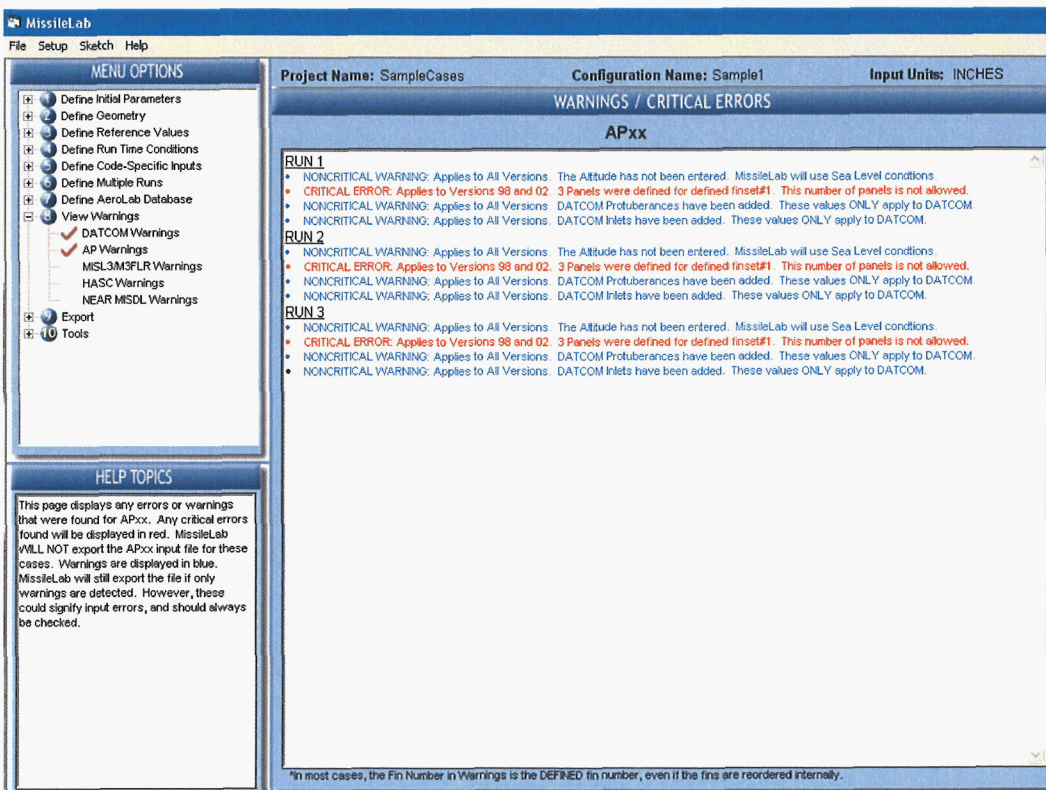

Figure 48. AP Warning Screen

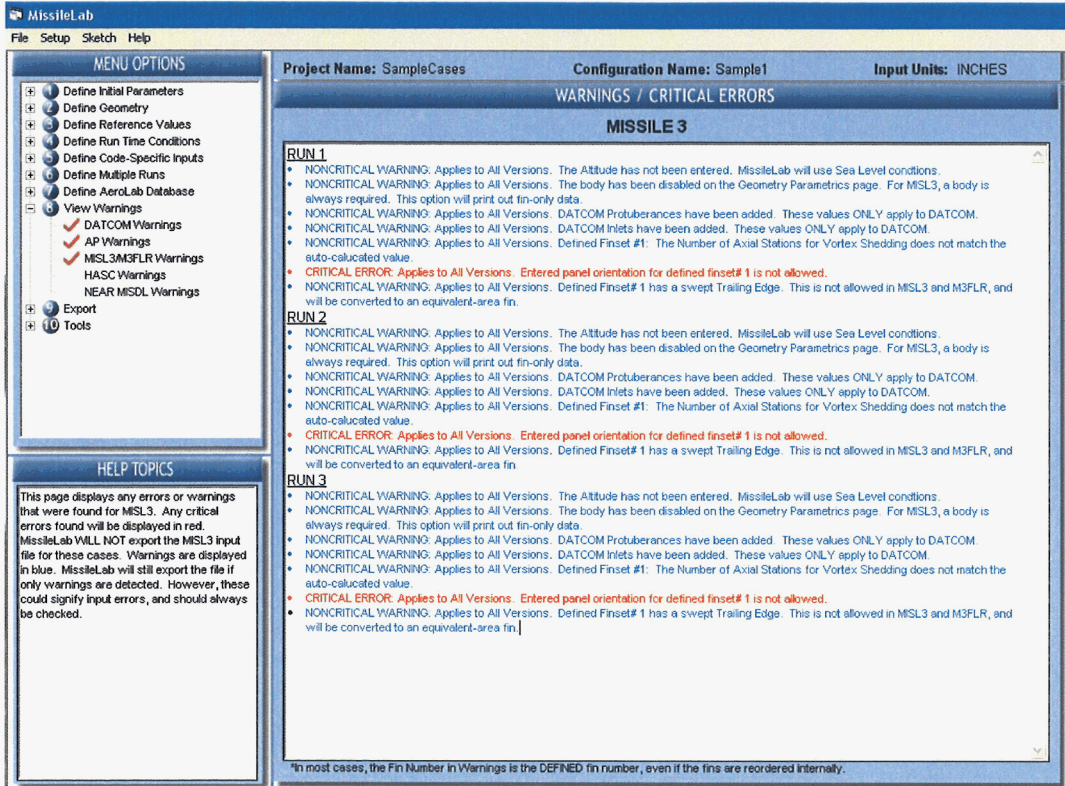

Figure 49. NEAR MSL3 Warning Screen

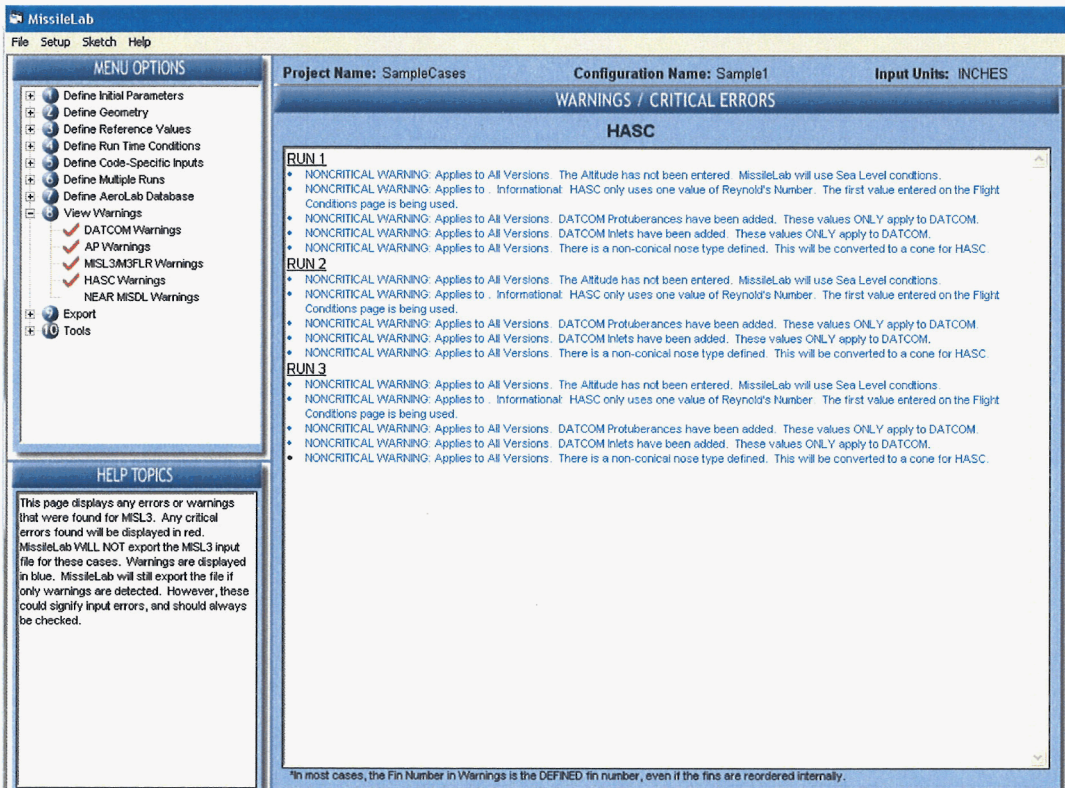

Figure 50. HASC Warning Screen

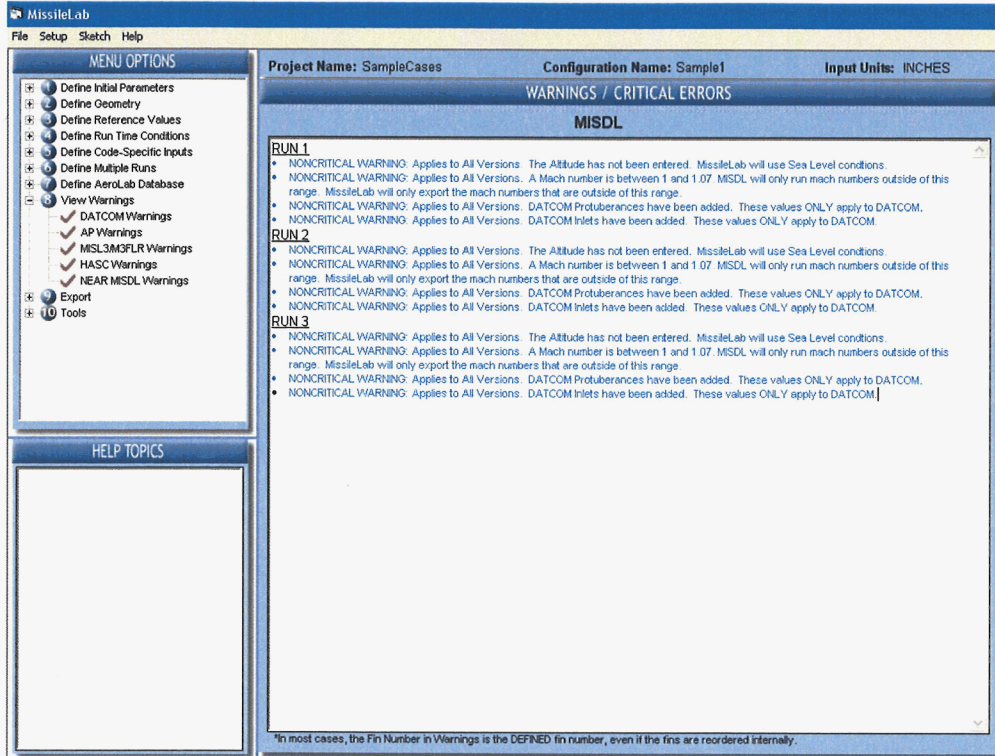

Figure 51. MISDL Warning Screen

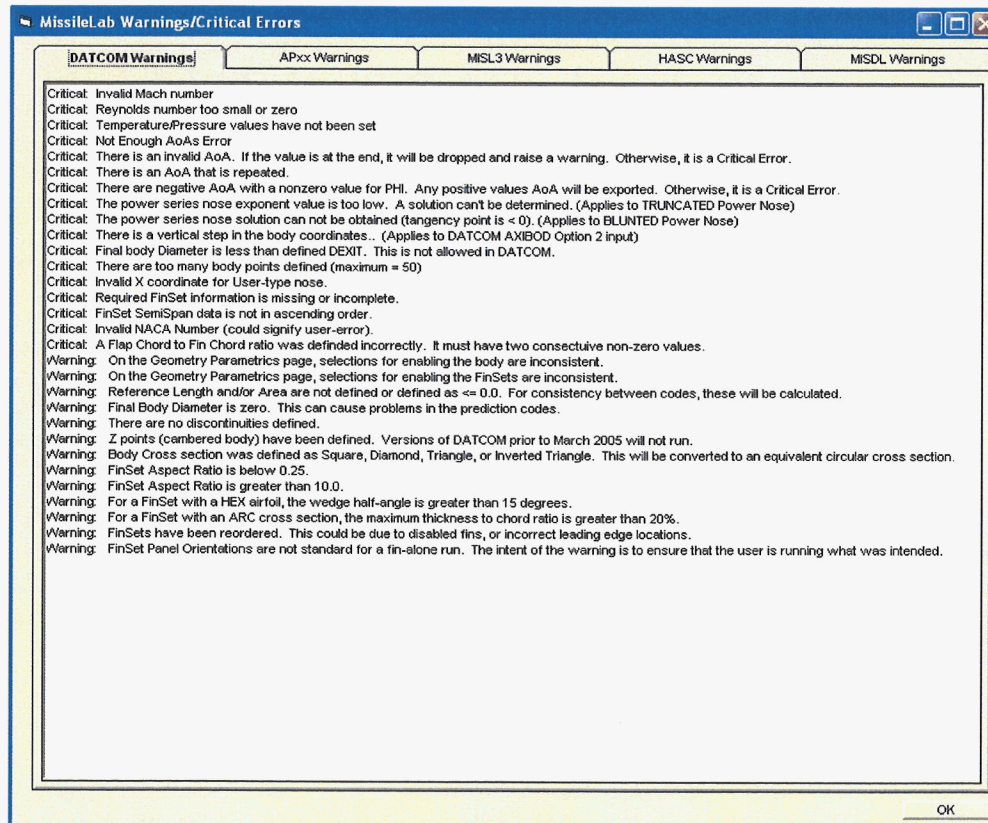

Figure 52. List of Error and Warning Checks

9. Export Data and 3-D Models Screen

Export Data Files / Run Predictions Screen: Figure 53 presents the “Export Data” screen. Here, the user selects the desired prediction code(s) to be executed. As shown in the figure, if MissileLab identifies a critical error in the geometry input for a specific APE, then that code is disabled for the current case. The warnings page discussed previously lists the critical errors and warning messages. The user should always view the warnings page, even if no critical errors are noted.

The APEs may only be selected if no critical errors were found. If a critical error was found, MissileLab disables the specific APE. When a prediction code is selected, the associated input file is also selected for generation. Alternatively, the user may request that MissileLab produce a given input file without running the prediction program.

Once the desired APEs have been selected, the user clicks on the “Export Data / Run Codes” command button. This initiates generation of the APE input files and execution of the selected engines. As each engine terminates, its respective output file is saved to the hard disk, and if the “View Output Files” checkbox is checked, the results are then displayed in Windows NotePad text viewer.

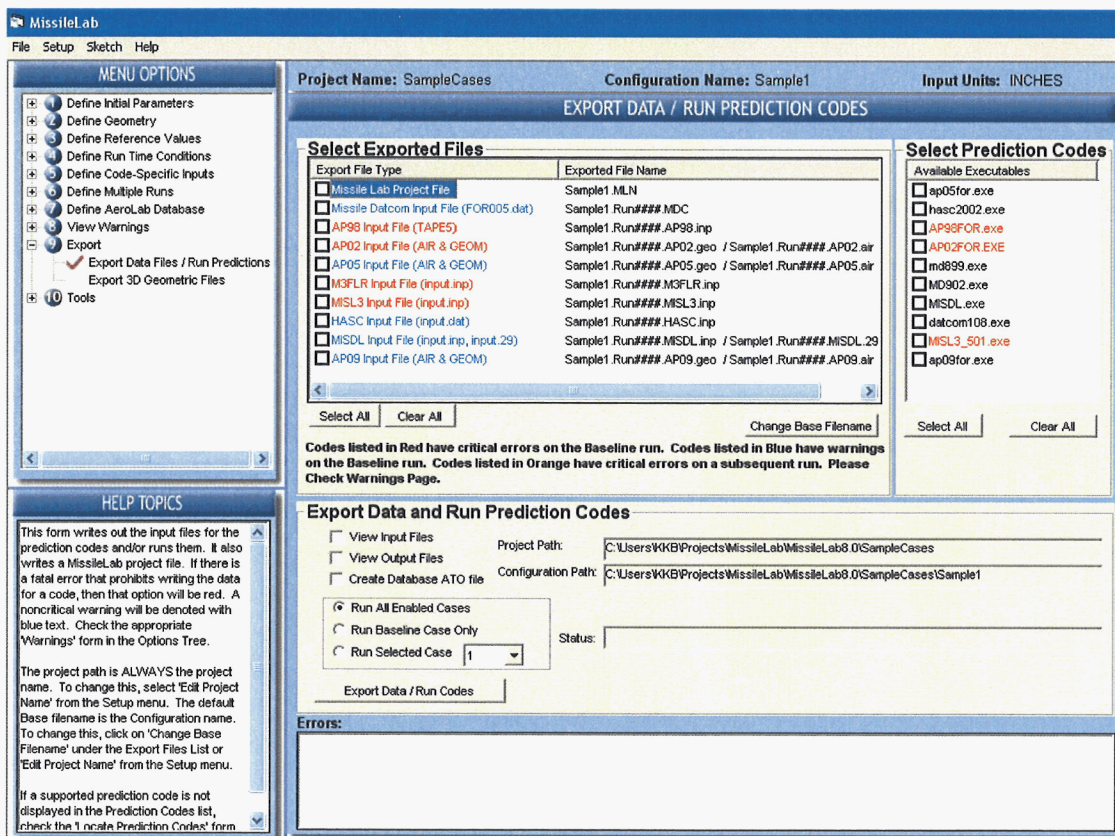

Figure 53. Export Data Screen

When the “Export Data / Run Codes” command button is selected, MissileLab creates the APE input files in the directory where the specific APE executable is located (as specified by the user under the “Locate Prediction Codes” screen discussed previously in Section III.A.2). Before these files are written, however, MissileLab DELETES any pre-existing native input/output files for the specific APE. This is why it is recommended that the user place the APEs in a separate directory that only MissileLab will access. After the specific APE terminates, MissileLab copies the native output files into the standard MissileLab directory structure.

Missile DATCOM and APxx codes do not require any extra input from the user apart from the input files. NEAR MISL3, however, requires “command prompt input” from the user in addition to the standard MISL3 input file. As this is not desirable from MissileLab’s perspective, the following additional files are created for NEAR MISL3 operation.

First MissileLab creates a text file named “temp.txt” that is written to the directory where the MISL3 executable resides. This file contains the “command prompt” inputs that the user would normally have to enter, and the contents of this file are listed in Table 6. The values that are defined in this file are set on the MISL3 Specific Input screen discussed in Section III.D.7. MissileLab also creates a DOS batch file named “RunMISL3.exe.bat” that is also written to the directory where the MISL3 executable resides. This file contains one line, which is:

“MISL3.exe < temp.txt”.

To run MISL3, MissileLab executes the “RunMISL3.exe.bat” batch file.

Table 6. MISL3 Command Prompt Inputs via the Temp.txt File

Line	Value	Description
1	Input.inp	Input file name
2	Output	Output file name
3	“Y” or “N”	“Y” – Create NEAR MG3 output files (Units 1, 2, & 3)
4	“Y” or “N”	“Y” – Create Control Points output files (Units 16 & 17)
5	“Y” or “N”	“Y” – Create comma delimited output files (Units 60 & 61)
6	“Y” or “N”	“Y” – Create TechPlot output files (Units 62 and 63)

Export 3-D Geometric Files Screen: The major new innovation to MissileLab version 7 was the introduction of an export option for 3-D models in the NASA CART3D “tri” file format and the Standard Tessellation Language (STL) format. This capability allows the user to quickly generate 3-D models that may be read by NASA’s OVERGRID code, used as input to the NASA CART3D Euler flow solver suite or read into a number of CAD and other 3-D modeling applications.

This new functionality is accessed via the export screen shown in Figure 54.a. These models may take several minutes to export!

Once the MissileLab generated “tri” file is created and ported to a Linux computer where OVERGRID and CART3D reside, the first step in the process is to perform a DOS2UNIX command on the “tri” file to insure the proper end-of-line markers are present. Once this is done, the geometry may be viewed and manipulated (if desired) in OVERGRID. Use of OVERGRID is beyond the scope of this report.

With respect to the CART3D suite of codes, the “INTERSECT” application is used to read the MissileLab generated “tri” file and generate one single “water-tight” surface. Prior to running Intersect, the body, wing/fin panels, and protuberances are individual closed component surfaces. In this component form, OVERGRID may be used (if desired) to move, translate, rotate, and scale the individual “tri” file components. Once INTERSECT has been run, the resulting file is a single surface.

The CART3D intersect application is very sensitive to co-planar surfaces and surfaces that intersect exactly at vertices nodes from other components. Should these conditions happen, INTERSECT will fail and typical intersect error messages are extremely un-helpful in identifying the problem. For this reason, a number of controls are provided in the MissileLab export page that greatly increase the success rate for 3-D “tri” model geometries passing through intersect on the first attempt. These controls are the subject of the following paragraphs.

A check-box control to enforce triangle aspect ratios that are less than 2 is provided. This control ensures that the individual facets do not become “long and skinny” as this can at times cause erroneous moment results from CART3D.

Check-box controls are provided to insure that fins and protuberances extend into the body (i.e. do in fact intersect and do not have surfaces that are co-planar). If “offset fins into the body” is checked, there are two values that refine the control; they are “Offset into the body” and “Initial span offset” and both controls are given in fraction of root thickness. The first value projects the root chord in towards the center of the body in increments of the root chord thickness. The second value applies a very small adjustment to the location of the fin root to insure that the fin root is not co-planar with the body surface. The check-box controls for the protuberances and inlets work in a similar fashion.

By default MissileLab places 72 slices (every 5 degrees) around the circumference of the body. If the body has a triangular or square cross-section with corner radii, MissileLab uses four slices to model each radius by default. Similar controls are available for fins, protuberances, and inlets. These controls, coupled with the facet aspect-ratio control, can lead to a very large number of facets which may require several minutes to write to the geometry file.

All facets are defined using the Right-Hand Rule (RHR) so that the facet surface normal is pointed out from the component.

The Draw Geometry and Export buttons in the lower-right corner of the screen allow the user to view and create the 3-D geometry model.

The Export Body Coordinates screen shown in Figure 54.b allows the user to define specific longitudinal coordinates for export to a text file. This information can be useful in setting-up panel code input files. The three formats supported are a Plot3d file, a Coordinates file, and a S/HABP geometry input file. For the S/HABP file, panel breaks can be designated in the Longitudinal Stations grid by “right-clicking” on the point, and selecting “Toggle End of Panel”.

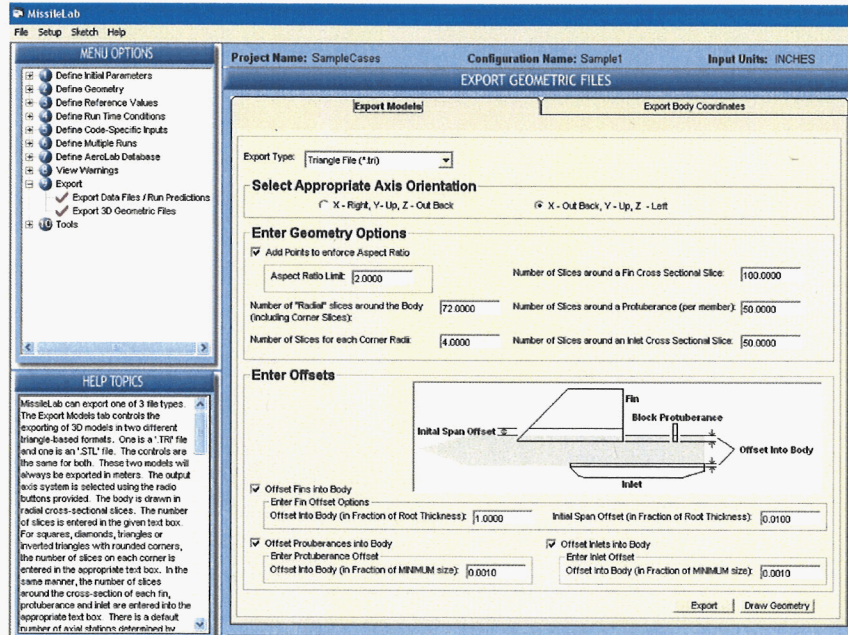

(a) STL and TRI 3-D Model Export

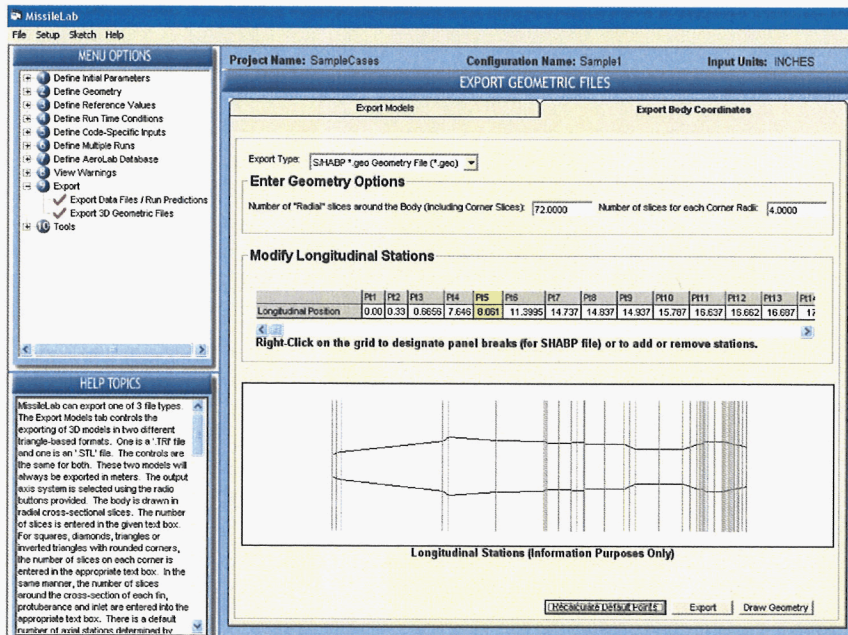

(b) Body Coordinate Export

Figure 54. Export 3-D Geometric Model Screen

10. Tools

Quick-Look Plots Screen: The “Quick-Look Plots” screen shown in Figure 55 can be used to generate graphs of the APE output. This feature only supports the DATCOM 042 file, the APxx TAPE6.ou2 file (generated from AParser), the MISL3 ldr.csv file, and the MISDL .csv file. Any of these that were generated during the current session will automatically be loaded and a set of plots automatically generated. The “Add File” button will allow the user to open any other file that is in one of the formats listed above. In multiple-run sessions, only output files from the baseline run will automatically be loaded.

The panel on the left side of the screen shows loaded files in a treeview, with their variables listed below. These variables can be checked and then plotted versus either Mach or Alpha by clicking on the appropriate button below the panel. All variables that are checked will be plotted on the same graph. The “Select Graph” pull-down menu will contain all of the graphs that have been added. The selected graph will be displayed with buttons for each Alpha or Mach. The “Copy” button will copy the graph to the clip-board. There are buttons to toggle grid lines and the legend. The legend may also be moved by “clicking and dragging” the legend box. The “Remove Plot Group” button will remove the selected graph (for all mach numbers or alphas).

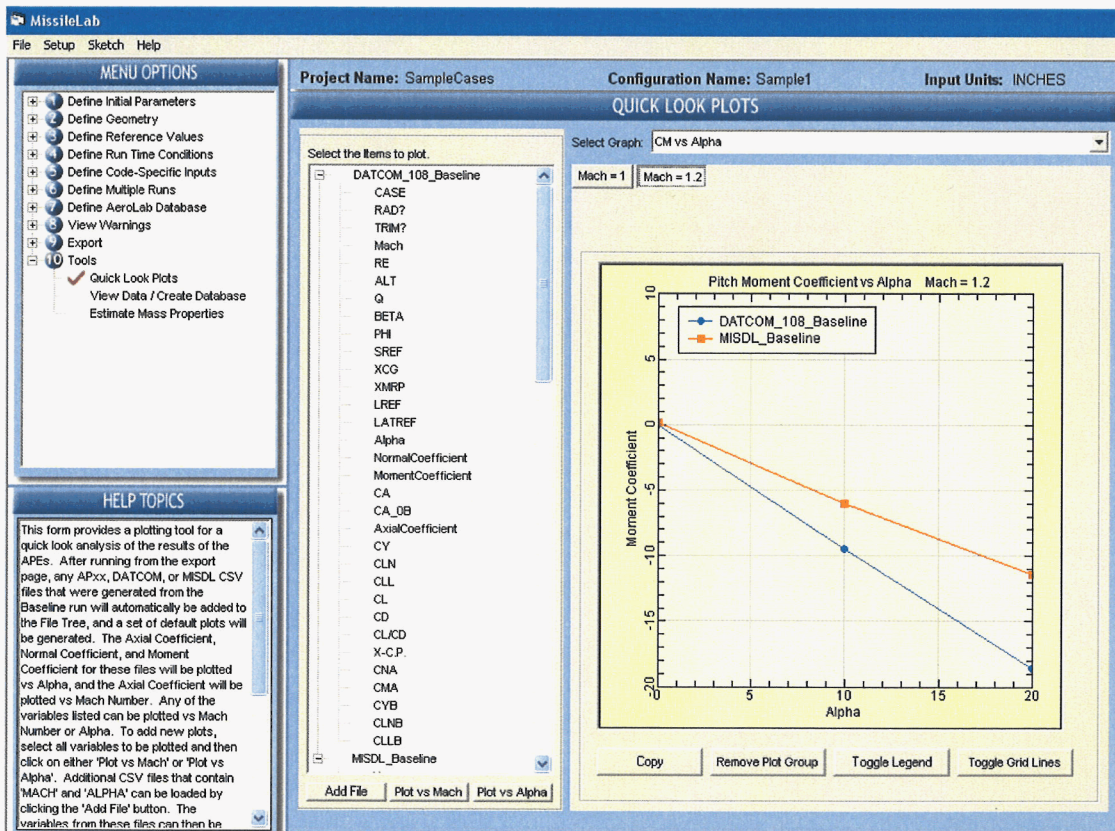

Figure 55. Quick-Look Plots Screen

View Data / Create Database Screen: If the configuration has ever been run in MissileLab, regardless if it was run in the current session or not, the results may be viewed by using the “View Data” screen shown in Figure 56. The latest version of Missile DATCOM (January 2006) outputs a new file referred to as the ‘042’ file. Similarly, the Python script tool, APparse, discussed in this document was written to post-process the APxx files and produce an AP results file that has a format very similar to the DATCOM 042 file.

This screen also contains the controls for building an AeroLab database once all cases have been run.

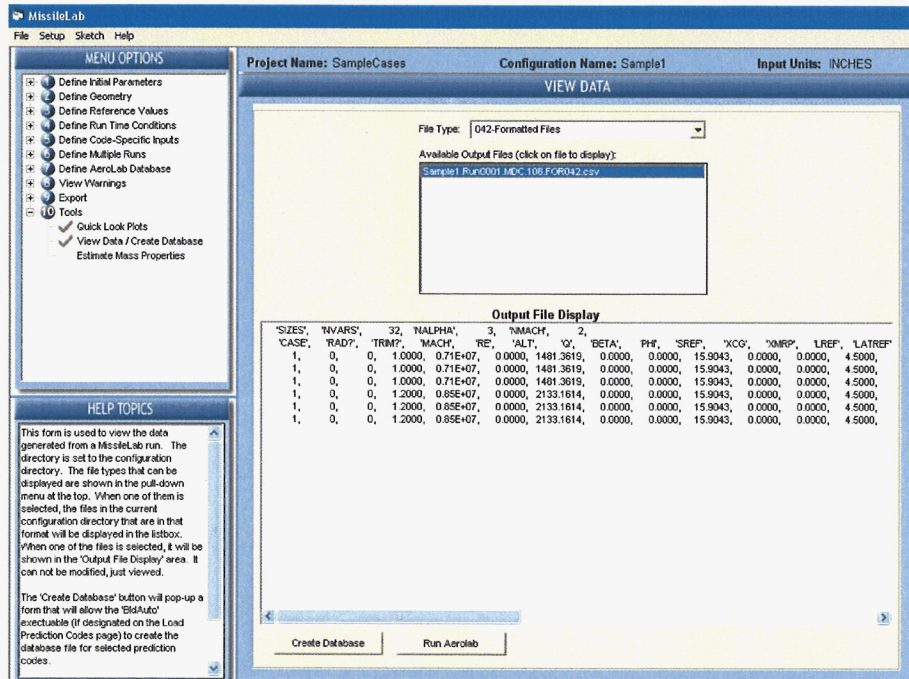

Figure 56. View Data Screen

Estimate Mass Properties Screen: A calculator for estimating mass properties of the configuration is provided and shown in Figure 57. Data from previous screens are used to automatically populate the screen as shown. The user may change these values and add or delete components. After entering weights for each component, the Calculate Mass Properties button estimates the mass properties of the configuration.

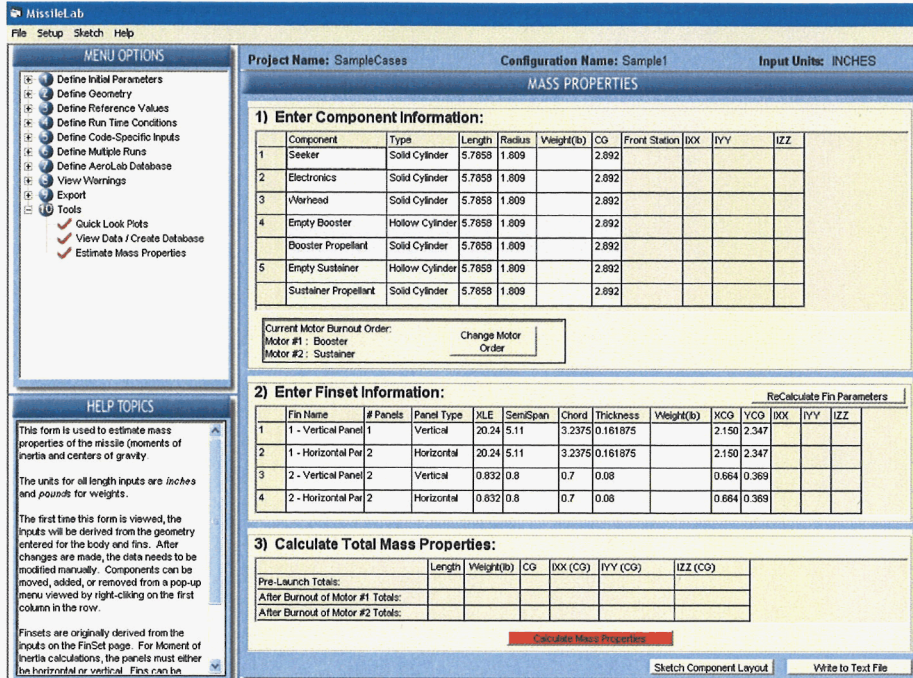

Figure 57. Mass Properties Estimator Tool

IV. EXAMPLE CASES

A. Project_101

This sample case is the canard-controlled missile illustrated in Figure 58 and summarized in Tables 7 through 10.

As none of the canard or fin thickness or breaklines are specified in the tables listed, the DATCOM defaults are assumed and used to generate the APxx and NEAR MISL3 input decks.

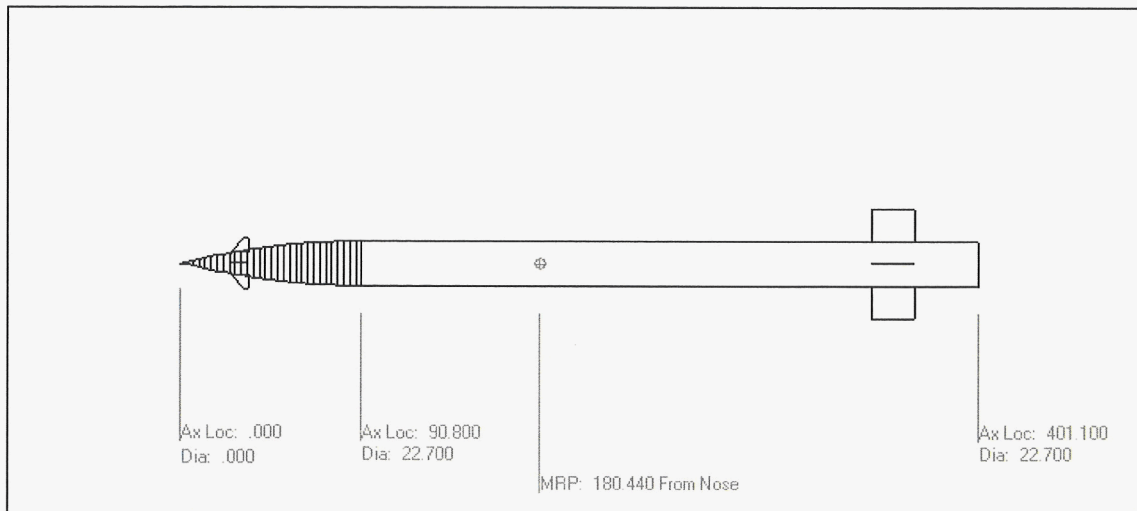

Figure 58. Project 101 Configuration

Table 7. Project 101 Reference Geometry

Reference Length	22.7000 cm
Reference Area	404.7079 cm ²
Moment Reference Point (from Nose tip)	180.4400 cm

Table 8. Project 101 Body Geometry

Type of Nose	Pointed Tangent Ogive
Length of the Nose	90.80 cm
Diameter at the base of the Nose ¹	22.70 cm
Length of the Center-body Section	310.30 cm
Diameter at the base of the Center-body Section ¹	22.70 cm

Notes: MissileLab requires the RADIUS be entered.

Table 9. Project 101 Canard Geometry

Airfoil Section Type	Hex
Distance from nose tip to LE of Root chord	25.01 cm
Distance from nose tip to LE of Tip chord	31.70 cm
Radial distance from centerline to root chord	6.17 cm
Radial distance from centerline to tip chord	13.17 cm
Root chord	9.19 cm
Tip chord	2.50 cm
Leading Edge Radius	0.02 cm
Number of Panels	4
Location of Panels	0, 90, 180, 270-deg

Table 10. Project 101 Fin Geometry

Airfoil Section Type	Hex
Distance from nose tip to LE of Root chord	347.80 cm
Distance from nose tip to LE of Tip chord	347.80 cm
Radial distance from centerline to root chord	11.35 cm
Radial distance from centerline to tip chord	28.16 cm
Root chord	21.50 cm
Tip chord	21.50 cm
Leading Edge Radius	0.052 cm
Number of Panels	4
Location of Panels	0, 90, 180, 270-deg

B. Project_102

This sample case is the tail-controlled missile illustrated in Figure 59. As seen from the figure, the third finset is closely coupled with the second finset. As such, there are two possible ways to model this configuration. The first method is to model all three finsets as shown in the figure and summarized in Tables 11 through 15. The second method is to model the body and first finset normally (as summarized in Tables 11 through 13), and then to treat the “wing+tail” as one finset but set the “flap to fin chord ratio” flag as summarized in Table 16. As seen in this table the chord of the wing and the chord of the tail were added together (and entered), and the ratio of the flap chord to the fin chord was included.

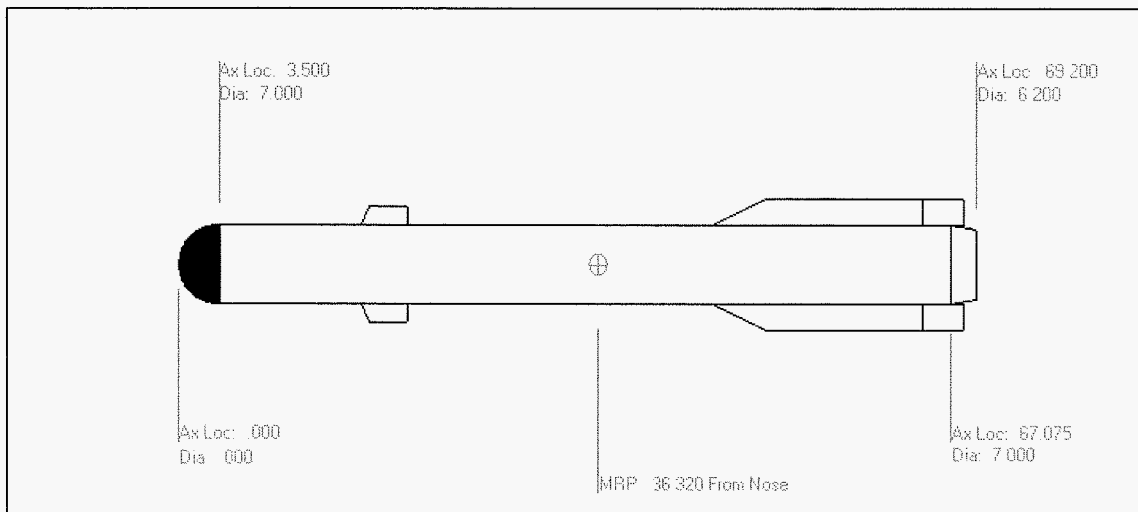

Figure 59. Project 102 Configuration

Table 11. Project 102 Reference Geometry

Reference Length	7.00 in
Reference Area	38.48451 in ²
Moment Reference Point (from Nose tip)	36.32 in

Table 12. Project 102 Body Geometry

Type of Nose	Pointed Tangent Ogive (Hemisphere)
Length of the Nose	3.500 in
Diameter at the base of the Nose	7.000 in
Length of the Center-body Section	63.575 in
Diameter at the base of the Center-body Section	7.000 in
Type of After-body	Conical
Length of the After-body Section	2.125 in
Diameter at the base of the After-body Section	6.200 in

Notes: MissileLab requires the RADIUS be entered.

Table 13. Project 102 Canard Geometry

Airfoil Section Type	HEX
Distance from nose tip to LE of Root chord	15.79 in
Distance from nose tip to LE of Tip chord	16.37 in
Radial distance from outer mold line to root chord	0.000 in
Radial distance from outer mold line to tip chord	1.625 in
Root chord	4.000 in
Tip chord	3.420 in
Leading Edge Radius	0.000 in
Thickness of airfoil	Root 0.16; Tip 0.06293
Length of LE wedge	Root 0.20; Tip 0.17100
Length of flat section	Root 3.60; Tip 3.07800
Number of Panels	4
Location of Panels	45, 135, 225, 315

Table 14. Project 102 Wing Geometry

Airfoil Section Type	HEX
Distance from nose tip to LE of Root chord	46.23 in
Distance from nose tip to LE of Tip chord	50.95 in
Radial distance from outer mold line to root chord	0.000 in
Radial distance from outer mold line to tip chord	2.320 in
Root chord	18.340 in
Tip chord	13.620 in
Leading Edge Radius	0.000 in
Thickness of airfoil	Root 0.3668; Tip 0.2724
Length of LE wedge	Root 0.917; Tip 0.681
Length of flat section	Root 16.506; Tip 12.258
Number of Panels	4
Location of Panels	45, 135, 225, 315

Table 15. Project 102 Tail Geometry

Airfoil Section Type	HEX
Distance from nose tip to LE of Root chord	64.57 in
Distance from nose tip to LE of Tip chord	64.57 in
Radial distance from outer mold line to root chord	0.000 in
Radial distance from outer mold line to tip chord	2.320 in
Root chord	3.500 in
Tip chord	3.500 in
Leading Edge Radius	0.000 in
Thickness of airfoil	Root 0.35; Tip 0.14
Length of LE wedge	Root 0.175; Tip 0.175
Length of flat segment	Root 3.15; Tip 3.15
Number of Panels	4
Location of Panels	45, 135, 225, 315

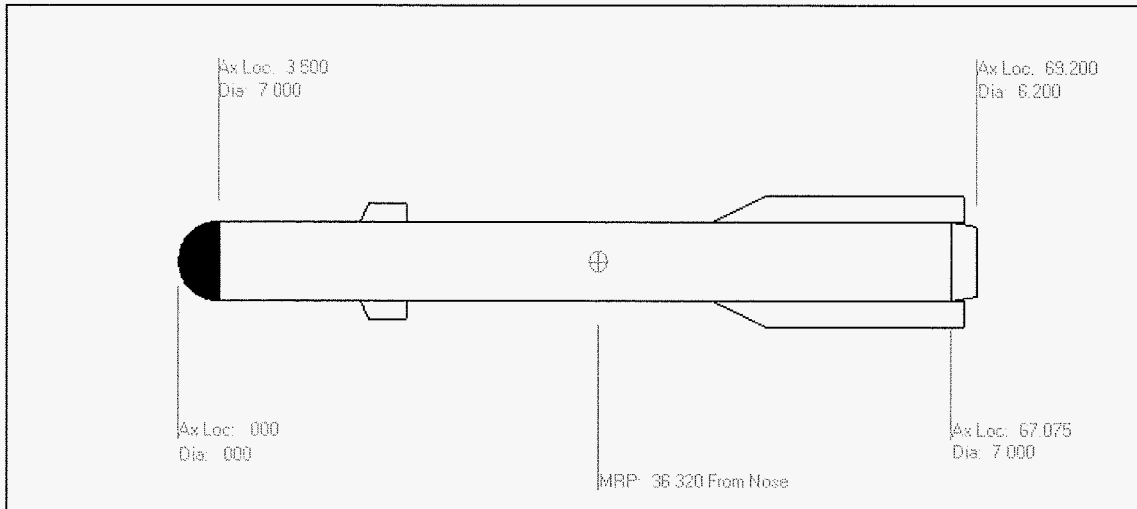

Figure 60. Project 102 Alternate Wing+Tail Modeling Approach

Table 16. Project 102 Alternate Wing+Tail Geometry Modeling Approach

Airfoil Section Type	HEX
Distance from nose tip to LE of Root chord	46.23 in
Distance from nose tip to LE of Tip chord	50.95 in
Radial distance from outer mold line to root chord	0.000 in
Radial distance from outer mold line to tip chord	2.320 in
Root chord	21.840 in
Tip chord	17.120 in
Ratio of Flap Chord to Fin Chord	Root 0.160; Tip 0.204
Leading Edge Radius	0.000 in
Thickness of airfoil	Root 0.4368; Tip 0.3424
Length of LE wedge	Root 1.092; Tip 0.856
Length of flat section	Root 19.656; Tip 15.408
Number of Panels	4
Location of Panels	45, 135, 225, 315

C. Project_103

This sample case is the tail-controlled missile illustrated in Figures 61 and 62, and is summarized in Tables 17 through 20. As seen from the figure, the wing and the tail are made up of multiple sections.

As APxx and NEAR MISL3 require “simple” fin geometry, MissileLab takes the input geometry for a multi-section wing/fin panel and attempts to calculate an equivalent fin planform. When entering multi-section fin panels, it is always recommended that the user examine the equivalent wing/fin geometry with a critical eye.

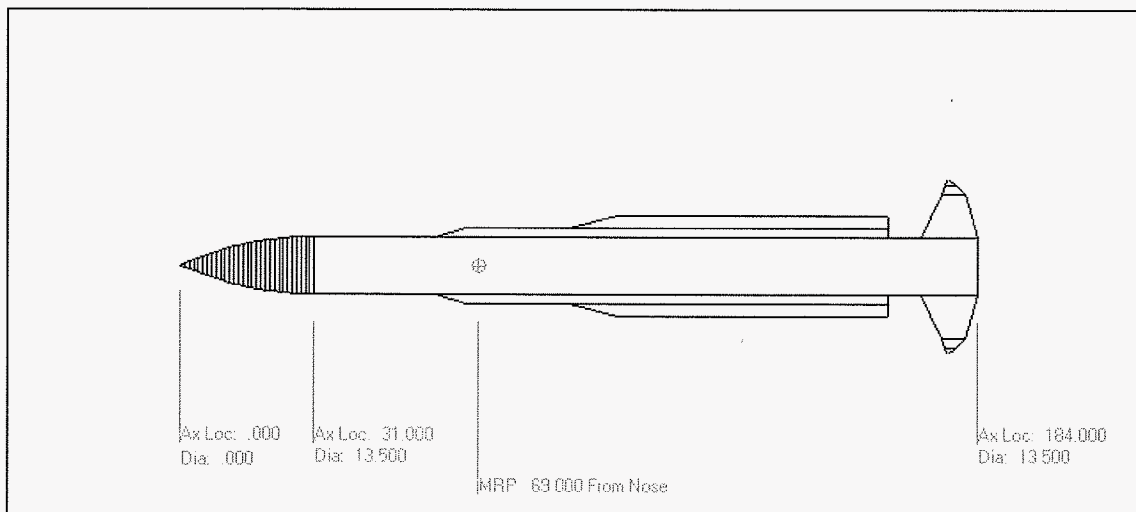

Figure 61. Project 103 Configuration Line Sketch

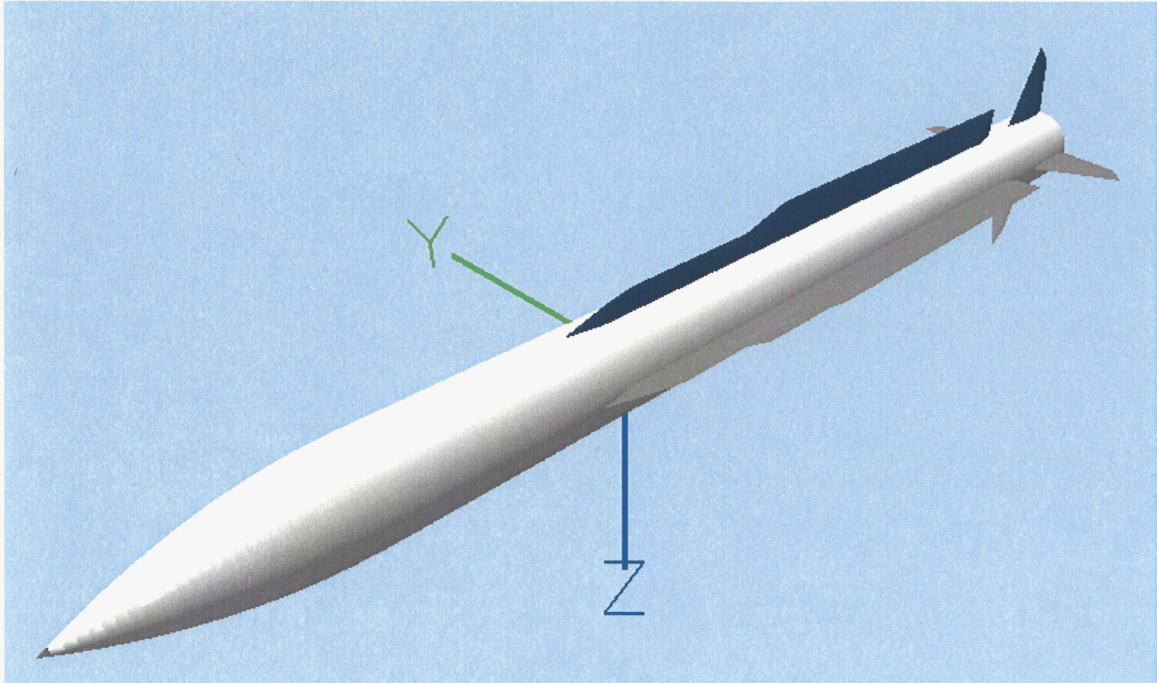

Figure 62. Project 103 Configuration 3-D Sketch

Table 17. Project 103 Reference Geometry

Reference Length	8.000 in
Reference Area	50.26548 in ²
Moment Reference Point (from Nose tip) ¹	69.000 in

Table 18. Project 103 Body Geometry

Type of Nose	Pointed Tangent Ogive
Length of the Nose	31.00 in
Diameter at the base of the Nose ¹	13.50 in
Length of the Center-body Section	153.00 in
Diameter at the base of the Center-body Section ¹	13.50 in

Notes: MissileLab requires the RADIUS be entered.

Figures 63 and 64 present the MissileLab generated “equivalent fin” geometry for AP cases. If the user does not feel that this is an accurate “equivalent fin,” then he must re-define the fin geometry on the main finset screen.

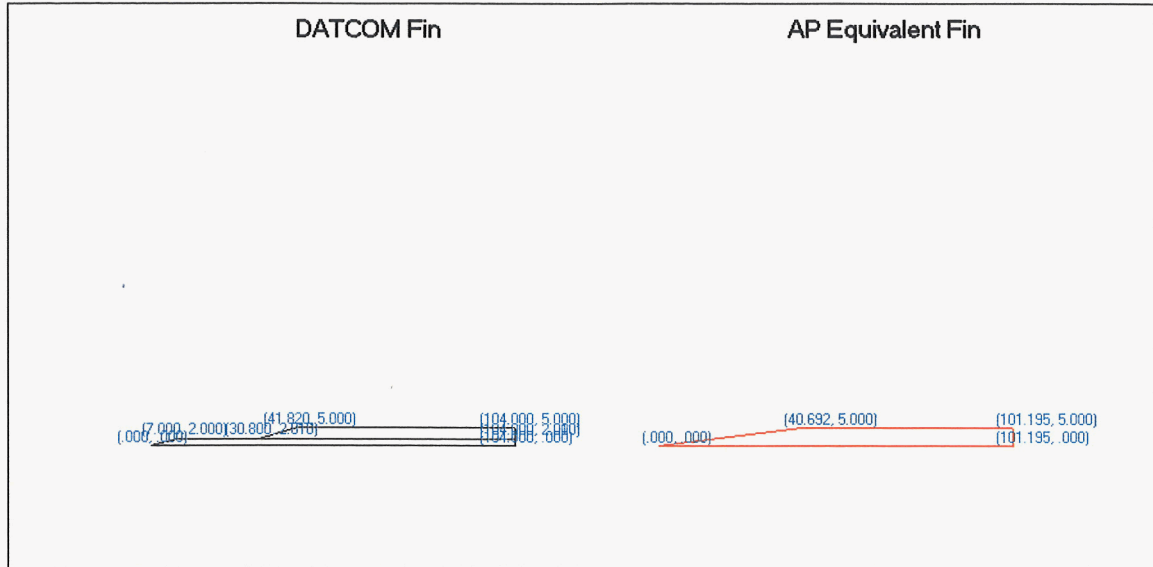

Figure 63. Project 103 Equivalent Wing Sketch

Table 19. Project 103 Wing Geometry

Airfoil Station	Root	2	3	Tip
Airfoil Section Type	HEX			
Distance from nose tip to LE of Root chord	59.1	--	--	--
Radial distance from centerline to chord section	6.75	8.75	8.76	11.75
Chord	104.00	97.00	73.20	62.18
Sweep of TRAILING EDGE	0	0	0	0
Leading Edge Radius	0.125	0.125	0.050	0.050
Number of Panels	4			
Location of Panels	0, 90, 180, 270-deg			
Thickness of airfoil	1.9968	1.9982	1.99104	0.24872
Length of LE wedge	5.2	5.335	5.124	4.9744
Length of flat section	93.6	86.33	62.952	52.2312

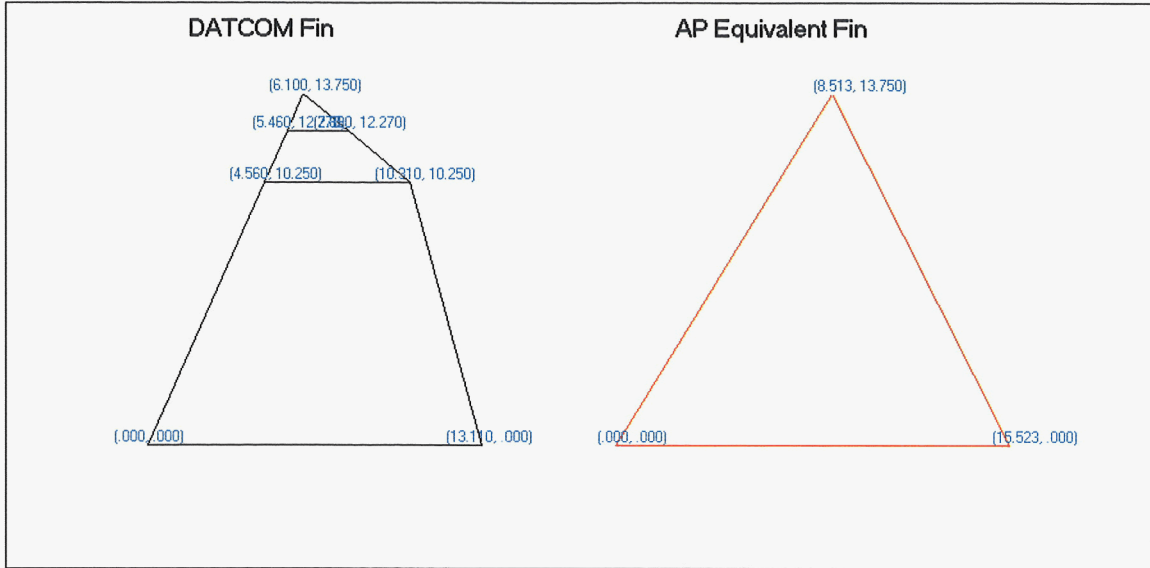

Figure 64. Project 103 Equivalent Wing Sketch

Table 20. Project 103 Tail Geometry

Airfoil Station	Root	2	3	Tip
Airfoil Section Type	HEX			
Distance from nose tip to LE of Root chord	171.0	175.56	176.46	177.1
Radial distance from centerline to chord section	6.75	17.00	19.02	20.50
Chord	13.11	5.75	2.43	0.00
Leading Edge Radius	0.05	0.05	0.05	0.05
Number of Panels	4			
Location of Panels	0, 90, 180, 270-deg			
Thickness of airfoil	1.11435	.48875	.20655	0.00
Length of LE wedge	3.933	2.6795	2.43	0.00
Length of flat section	5.244	0.00	0.00	0.00

V. FREQUENTLY ASKED QUESTIONS (FAQ)

- (Q) I am trying to load an existing DATCOM file and MissileLab seems to “hang-up” when reading the file. What is the problem?
- (A) It is most likely that the existing DATCOM file is missing or has a misplaced comma. You should carefully inspect the DATCOM input file, then try and re-load the file after correcting any comma errors.
- (Q) I am trying to read an existing DATCOM file and a variable is not being interpreted correctly.
- (A) The DATCOM reader was developed based on existing DATCOM documentation. Sometimes DATCOM allows things that the manual does not address. Check the manual and try changing the input to conform to what the manual states.
- (Q) How does the reference area calculator button (on the Body Reference screen) work with non-circular body cross-sections (on the Body Geometry screen)?
- (A) **Version 6 and earlier:** The reference area calculator button calculates the area of a circle using the characteristic reference length as the diameter of the circle regardless of what body cross-section is specified. If the user wishes to use any other value for reference area, simply enter that value if the reference area text box.
- (A) **Version 7 and later:** MissileLab version 7 calculates the reference area of the maximum body cross-section of the input body shape and sets the reference length to be the diameter of a circle with equivalent area.
- (Q) I entered the number of fin panels but not the orientation. The AP codes will not run. Why?
- (A) If the fin panel orientations are not entered, then the DATCOM defaults are used. These may not be valid orientations for the other codes.
- (Q) I opened an existing project and I can't modify anything now. Why?
- (A) If a project is opened with multiple cases, then the baseline case is automatically locked. This should be denoted by a “padlock” button at the top left corner of the form. To unlock the baseline case, simply click that button. However, BE CAREFUL. Changes to the baseline case might have an effect on other cases!

- (Q) I added a case on the Case Manager page and now I can't modify my baseline case. Why?
- (A) If any additional cases were added, then the baseline case is automatically locked. This should be denoted by a "padlock" button at the top left corner of the form. To unlock the baseline case, simply click that button. However, BE CAREFUL. Changes to the baseline case might have an effect on other cases!
- (Q) On the body page, how do I designate body option 1 or 2 (AXIBOD or ELLBOD) for DATCOM?
- (A) From MissileLab, this is not necessary. You can input the body in a way that makes sense. MissileLab will determine which option to send to DATCOM. If "User-Defined" is selected for the nose, a Midbody segment, or the Aft segment, then Option 2 is automatically used. Also, if multiple midbody segments are selected, Option 2 is used.
- (Q) On the Base Effects page, I tried to enter Base Plume Interaction data but the grid was not large enough. Why?
- (A) The Base Plume Interaction (as well as numerous other inputs) are Mach number dependent. Check to make sure that you have correctly input the Mach numbers on the Flight Conditions page.
- (Q) I have entered a finset on the Finsets page but it does not get exported to the output files nor do they show up on the geometry sketcher.
- (A) To allow easy changing of the body geometry, the Geometry Parametrics page allows the user to turn on/off fins and other geometric parameters. Check to make sure that the finsets are turned on on the Geometry Parametrics page.
- (Q) When I go to the Deflections/Trim page, the finset I want to deflect/trim doesn't show as an option.
- (A) Check the Geometry Parametrics page to make sure that the Finset is designated for Control.

- (Q) How do I clear my “Recently Used Files” list?
- (A) Version **6 and earlier**: Locate the “REGEDT32.EXE” program which is typically located in your “\Windows\System32” directory. **BE VERY CAREFUL what you do here!** Locate the “MissileLab” entry, and under that you should find a “Files” entry. This is where the “recently used files” are stored. Locate the files you wish to delete – and be VERY CAREFUL!
- (A) Version **7 and later**: Locate and delete the “MLRecentFiles.ini” in the directory where MissileLab is installed.
- (Q) Why is the “Sketch 3-D Missile” option under the “Sketch” menu grayed out?
- (A) If 3-D graphics are not desired, the Include3d flag in the INI file can be set to 0. This can also be done from the Locate Manuals / Set Options menu under Options. Check to see if this has been set to 0. Setting it to 1 should enable this feature.
- (Q) Why does my computer seem to run slow after using the 3-D sketch feature in MissileLab?
- (A) On some graphics card, the 3-D graphics will run slowly. To disable the 3-D graphics, go to the “Locate Manuals / Set Options”. Allow MissileLab to write a new Initialization file to disable the 3-D graphics every time MissileLab is run.
- (Q) Why does my computer not display the 3-D windows correctly?
- (A) MissileLab uses 3-DLinx to generate the 3-D windows. This software uses OpenGL to draw the scene. Some graphics cards may not fully support OpenGL. Many times this can be corrected by downloading a new driver for the graphics card. This may need to be done even on new machines.

REFERENCES

1. Blake, Missile DATCOM: Users' Manual – 1997 FORTRAN 90 Version, Air Force Research Laboratory, AFRL-VA-WP-TR-1998-3009, Feb 1998.
ADL001\DOCUMENTS\TRRDSS93X.PDF.
2. Moore, McInville, Hymer, The 1998 Version of the NSWC Aeroprediction Code – Part 1: Summary of New Theoretical Methodology, Naval Surface Warfare Center, Dahlgren Division, NSWCDD/TR-98/1, April 1998
3. Moore, Hymer, Downs, Users' Guide for an Interactive Personal Computer interface for the 1998 Aeroprediction Code (AP98), Naval Surface Warfare Center, Dahlgren Division, NSWCDD/TR-98/7, June 1998
4. Moore, Hymer, The 2002 Version of the Aeroprediction Code – Part 1: Summary of New Theoretical Methodology, Naval Surface Warfare Center, Dahlgren Division, NSWCDD/TR-01/108-PT-1, March 2001.
5. Moore, Hymer, The 2002 Version of the Aeroprediction Code – Part 2: Users' Guide, Naval Surface Warfare Center, Dahlgren Division, NSWCDD/TR-02/34, May 2002.
6. Moore, Hymer, The 2005 Version of the Aeroprediction Code – Part 1: Summary of New Theoretical Methodology, Aeroprediction INC, King George, VA.
7. Moore, Hymer, The 2005 Version of the Aeroprediction Code – Part 2: Users' Guide, Aeroprediction INC, King George, VA.
8. Moore, Moore, The 2009 Version of the Aeroprediction Code: The AP09, Aeroprediction INC, King George, VA.
9. Lesieutre, Love, Dillenius, MISL3 – Aerodynamic Analysis for Finned Vehicles with Axisymmetric Bodies, Nielsen Engineering and Research INC, NEAR TR-561, May 2001.
10. Lesieutre, Love, Hegedus, Dillenius, Perkins, Detailed Aerodynamic Prediction Program MISDL Version January 2006 Code User's Manual, Nielsen Engineering and Research INC, NEAR TR-610, January 2006.
11. Albright, Dixon, Hegedus, "Modification and Validation of Conceptual Design Aerodynamic Prediction Method HASC95 with VTXCHN", Lockheed Martin Tactical Aircraft Systems, November 1995.
12. Gentry, Arvel E., Smyth, Douglas S., and Oliver, Wayne R., "The Mark IV Supersonic-Hypersonic Arbitrary-Body Program", Volumes 1 – 3, Technical Report AFFDL-TR-73-159, 1973.

REFERENCES (CONTINUED)

13. Blackmar, Miller, Blake, "Approximate Methods for Center of Pressure Prediction of Multi-Segment Wings," AIAA paper 2003-3934, Presented at the 21st Applied Aerodynamics Conference, Orlando, FL, June 2003.
14. Auman, Tauchen, AeroLab Users' Guide, U.S. Army Aviation and Missile Command, TR-RD-SS-03-09, Redstone Arsenal, AL, April 2003.
15. Auman, Users' Guide to the Aerodynamic Database, U.S. Army Missile Command, TR-RD-SS-92-7, Redstone Arsenal, AL, April 1992.
16. 3-DLinx - a 3-D ActiveX Control developed by GlobalMajic Software, Huntsville, AL.
17. Blake, Karni, "A Cambered Body Method for Missile DATCOM," 23rd AIAA Applied Aerodynamics Conference, Toronto, Canada, AIAA-2005-4971, June 2005.
18. Blake, Auman, et. al., "Missile DATCOM User's Guide Manual – 2008 Version," AFRL Technical Report AFRL-RB-WP-TR-2009-3015, Wright-Patterson Air Force Base, OH, January 2009.