

STABILITY MEASUREMENTS OF Ku-BAND SPREAD  
SPECTRUM EQUIPMENT USED FOR TWO-WAY TIME TRANSFER

David A. Howe  
National Bureau of Standards  
325 Broadway  
Boulder, CO 80303  
(303) 497-3277

ABSTRACT

The NBS Boulder Laboratory is in the process of assembling a very high accuracy time transfer system. The system includes a 6.1 meter Ku-band satellite earth station, two transportable earth stations each with a 1.8 meter dish, and commercial modems designed for two-way timing. Elements of the facilities are described in this paper. High-accuracy timing with this equipment using the two-way time transfer technique via a geostationary satellite is discussed. Phase stability measurements of ground facilities in various loop-around schemes using a satellite simulator have been performed in order to determine ultimate stability limits. Allan-variance stability plots are generated for sample times of 1 s to several days at various carrier-to-noise density ( $C/N_0$ ) ratios. These plots are compared to theoretical limits obtained from the model of phase jitter given for the spread spectrum modem.

The use of small transportable earth stations with full duplex capability provides for signal turn-around at a remote location with stationary satellites in common view with the NBS earth station. It is shown that the portability of the small earth stations readily allows a measurement of signal delays through the ground equipment including the orthomode transducer, feed, and other antenna-related items. Time delays through the various antenna parts have usually not been measured directly but have been estimated in previous papers on two-way time transfer.

High-accuracy time comparisons can be performed between NBS and other Ku-band satellite earth stations via geostationary satellites. Better than 1 ns accuracy should be possible using the two-way time transfer technique. The use of transportable, calibrated earth stations makes possible accurate measurement of the signal delay of an involved earth station by means of a calibration.

---

This work has been partially supported by the Rome Air Development Center under Contract F30602-85-0055.

Contribution of the National Bureau of Standards, not subject to copyright.

# Report Documentation Page

*Form Approved  
OMB No. 0704-0188*

Public reporting burden for the collection of information is estimated to average 1 hour per response, including the time for reviewing instructions, searching existing data sources, gathering and maintaining the data needed, and completing and reviewing the collection of information. Send comments regarding this burden estimate or any other aspect of this collection of information, including suggestions for reducing this burden, to Washington Headquarters Services, Directorate for Information Operations and Reports, 1215 Jefferson Davis Highway, Suite 1204, Arlington VA 22202-4302. Respondents should be aware that notwithstanding any other provision of law, no person shall be subject to a penalty for failing to comply with a collection of information if it does not display a currently valid OMB control number.

1. REPORT DATE <b>DEC 1986</b>	2. REPORT TYPE	3. DATES COVERED <b>00-00-1986 to 00-00-1986</b>			
4. TITLE AND SUBTITLE <b>Stability Measurements of Ku-Band Spread Spectrum Equipment Used for Two-Way Time Transfer</b>		5a. CONTRACT NUMBER			
		5b. GRANT NUMBER			
		5c. PROGRAM ELEMENT NUMBER			
6. AUTHOR(S)		5d. PROJECT NUMBER			
		5e. TASK NUMBER			
		5f. WORK UNIT NUMBER			
7. PERFORMING ORGANIZATION NAME(S) AND ADDRESS(ES) <b>National Bureau of Standards, 325 Broadway, Boulder, CO, 80303</b>		8. PERFORMING ORGANIZATION REPORT NUMBER			
9. SPONSORING/MONITORING AGENCY NAME(S) AND ADDRESS(ES)		10. SPONSOR/MONITOR'S ACRONYM(S)			
		11. SPONSOR/MONITOR'S REPORT NUMBER(S)			
12. DISTRIBUTION/AVAILABILITY STATEMENT <b>Approved for public release; distribution unlimited</b>					
13. SUPPLEMENTARY NOTES <b>Proceedings of the Eighteenth Annual Precise Time and Time Interval (PTTI) Applications and Planning Meeting, Washington, DC, 2-4 Dec 1986</b>					
14. ABSTRACT <b>see report</b>					
15. SUBJECT TERMS					
16. SECURITY CLASSIFICATION OF:			17. LIMITATION OF ABSTRACT <b>Same as Report (SAR)</b>	18. NUMBER OF PAGES <b>15</b>	19a. NAME OF RESPONSIBLE PERSON
a. REPORT <b>unclassified</b>	b. ABSTRACT <b>unclassified</b>	c. THIS PAGE <b>unclassified</b>			

## INTRODUCTION

The growth and development of satellite technology and services during the 1960's and 1970's has created a wealth of satellite communications opportunities for the 1980's. As a result a reliable global satellite network of geostationary satellite transponders is evolving. The fixed satellite service, or FSS, is available to users in a convenient way through a wide variety of service organizations. Furthermore, earth station operators now have new satellite frequencies available to them in the Ku-band (14/12 GHz) frequency range. An attractive aspect of the Ku-band satellite service is that small Ku-band earth station antennas located within a satellite's primary coverage area can deliver signal-to-noise ratios equivalent to larger C-band antennas (4 GHz frequency band). In the U.S. considerable channel capacity is already available and numerous Ku-band spacecraft are scheduled for launch in the next two to four years.

At the National Bureau of Standards Boulder Laboratories, a Ku-band satellite earth station has been installed for the purpose of performing two-way time transfer experiments through the FSS. In addition to this earth station with a 6.1 meter dish, two transportable earth stations, each with a 1.8 meter dish are also available for the experiments. Two-way time transfer is done through spread spectrum encoding using the Hartl/MITREX\* modems. Measurements of stability have been done in several different loop-around schemes of the ground segment in order to determine timing stability limits. Both "in-cabinet" and "free-space" loop-around tests were performed using a ground based satellite simulation. This then yields the time delay through the earth station equipment including the satellite dish and its orthomode transducer (OMT). This complete delay measurement along with the stability measurements provides the foundation for very high precision two-way time transfer since the delays through the involved earth stations and the stability of these delays are known.

## FACILITIES

The principal component for the Ku-band station is a 6.1 meter antenna located on top of the radio building at NBS, Boulder. The antenna is capable of geostationary orbital arc coverage from 35°W to 125°W. Positioning is accomplished by a motorized system with a microprocessor-controlled panel (elevation, azimuth, and polarization). For remote applications, we use a 1.8 meter small aperture terminal (often called VSAT for "very small aperture terminal" when the antenna diameter is 1.8 meters or less). This VSAT consists of a complete earth station RF package with 70 MHz input and output intermediate frequencies. The dish uses a J-hook prime focus feed system. The RF unit is attached to the dish and the entire assembly can be transported relatively easily. The mount is a simple elevation-over-azimuth assembly arranged using galvanized braces in a triangular configuration designed for resting directly on the ground or other horizontal surface. The 6.1 meter dish has a gain of 56 dB and has a low noise amplifier (LNA) with a 2.5 dB noise figure. The VSAT has a system noise temperature of less than 250 K (the

---

\*Identification of a commercial company does not imply recommendation or endorsement by the National Bureau of Standards, nor does it imply that any identified entity is the only or the best available for the purpose.

actual input noise figure is 1.5 dB, but is degraded by the antenna noise temperature and slightly degraded because of the waveguide transition and isolator losses) [1].

Figure 1 shows a picture of both the 6.1 meter dish and the VSAT portable terminal. Figure 2 shows a picture of the ground station equipment. The large dish is permanently located on the roof of a wing of the NBS radio building and the associated earth station equipment is in a room about 30 meters away. The LNA is located in the dish, and signals to and from the dish are fed by pressurized elliptic waveguide transmission lines. Figure 3 shows a block diagram of the main items comprising the earth station. Both the transmit and receive waveguides from the dish are fed to waveguide switches which are used to do the in-cabinet loop-around test. For many of the measurements the loop-around test incorporated the LNA. In the normal scheme, the 12 GHz signal following the LNA is fed to a commercial down converter which does a double conversion to 70 MHz. The 70 MHz signal is fed to the spread spectrum modem. Likewise, the 70 MHz transmit signal from the modem is fed to an up converter which does a complete translation to 14 GHz. A variable attenuator is used to drive a linear amplifier (GaAsFET amplifier) which is capable of a maximum power output of 1 watt. That signal is then fed to the waveguide transmission line going to the antenna. The waveguide switches used for the loop-around test are placed so that all the electronic components of the normal ground station scheme are in place. In the loop-around mode a directional coupler splits power to the satellite translator from the 14 GHz output of the GaAsFET amplifier. The satellite translator then retransmits the same signal at the standard 2.3 GHz offset (as determined by a frequency synthesizer). The output of the satellite translator then feeds a variable attenuator and the LNA which is normally in the dish is relocated after the attenuator. The output of the LNA is then fed to the attenuator/down converter.

A rubidium frequency standard is used for the 5 MHz and 1 pps reference signals for the modem. The start and stop pulses are measured using a time interval counter having a resolution of 35 picoseconds (rms) per second and the negative going transitions are detected. Auxiliary pieces of equipment include a spectrum analyzer and power meter. In addition, a computer is used for data analysis and is connected via an IEEE 488 Bus to the time interval counter.

Figures 4 and 5 show the "in-cabinet" and "free-space" loop test for the VSAT respectively. The VSAT RF unit (designated by its serial number, 182) contains all the transmit and receive converters and directly provides an input (for transmit) and output (for receive) at 70 MHz. In addition, there is a separate 70 MHz output for monitoring purposes. The 70 MHz input/output signals are fed directly to the modem through a coaxial cable which is 15 meters long. The modem's arrangement is identical to that used with the 6.1 meter dish. That is, the start and stop pulses for transmit and receive are fed to a high resolution time interval counter. Again, a rubidium standard furnishes 5 MHz and 1 pps reference signals for the modem. Data reduction is handled by a computer connected to the time interval counter. In-cabinet tests of the VSAT are performed without the dish, and the satellite translator is connected directly to (transmit and receive) waveguide ports as shown in Figure 4. Free-space tests are performed with the VSAT 1.8 meter dish fully deployed and the satellite translator is located a distance  $r$  away as shown in

Figure 5. Two horn antennas, one horizontally polarized and the other vertically polarized, are used in the free-space test for the satellite translator to simulate the orthogonal modes. Also, a LNA is used ahead of the satellite translator input to bring signal levels up above the equivalent input noise floor, the satellite translator having a very poor input noise temperature.

#### MEASUREMENT METHODS

Of interest in this paper is a relationship between standard frequency stability measurement techniques and standard satellite, signal-to-noise ratio parameters. In the case of frequency stability the measurement performed is the two-sample Allan variance of the phase noise of the ground segment in both in-cabinet and free-space, loop-around schemes. Frequency stability measurements from one second to a few thousand seconds were performed for various carrier-to-noise density ( $C/N_0$ ) ratios. Carrier-to-noise density ratio is a general figure of merit parameter for a satellite communications link. Frequency stability data also was taken at one day intervals to look at long term stability and its agreement with extrapolated short term stability results. The actual  $C/N_0$  measurement is made using a spectrum analyzer sampling the unmodulated pure RF carrier of the modem compared to the density of noise in a 1 Hz bandwidth. The spectrum analyzer had a minimum resolution bandwidth of 10 Hz but the noise component was white and allowed straightforward calculation to 1 Hz bandwidth. The analyzer incorporated a correction for doing noise bandwidth measurements at various analyzer settings. These corrections were found to be accurate to the rated specification of 1 dB by scanning the shape of the response curve and scaling the bandwidth as high as 100 kHz and (again assuming white noise) seeing correct closure of the equivalent noise bandwidth at 1 Hz. At low ( $C + N/N$ ) ratios, it is difficult to accurately measure the signal level because of the presence of the noise component. To overcome this difficulty the carrier signal was introduced at a higher level accurately measured by the analyzer and then a precision attenuator was applied to only the carrier in order to reduce its level to a known value.

Some data which is presented in the documentation which accompanies the Hartl modem is useful for the analysis of frequency stability presented here. Figure 6 shows a plot of the white noise phase jitter versus carrier-to-noise density ratio [2]. From these data a value for  $\sigma_y$ , the Allan variance can be computed and the value for 75 dB-Hz is included with the data. If we assume that the plot shown in Figure 6 is the classical variance about the mean of the phase jitter ( $\sigma_x^2$ ) then the relationship to the Allan variance is [3,4]

$$\sigma_x^2(\tau_0) = \frac{\tau^2 \sigma_y^2(\tau)}{3} .$$

Most measurements of ground equipment delays involve the timing of an injection RF pulse and the detection of the same pulse at a point before the antenna for the transmission portion. The delay measurement for the receive portion is done in the same way but with the injection pulse usually at the LNA and the envelope detector after the appropriate receive chain equipment. There are two common difficulties with this approach. The first is that the pulse injection and detection scheme itself introduces a measurement uncertainty since this is not the way the equipment normally operates. A more favorable measurement would be done in situ. Second, the measurement does not

include the antenna and its associated orthomode transducer and feed system. One cannot assume that the antenna differential delays are zero.

It is possible using the satellite translator and portable dish to perform in situ measurements of the absolute value for the total delay and the differential delay of the ground segment. To measure the round trip delay we use the free-space loop test scheme as shown in Figure 5. The free-space loop test data is taken at various values for the range  $r$ . One can then compute the value for the absolute round-trip time delay extrapolated to  $r = 0$  at the dish representing phase center of the dish. Although the measurements are taken in the near field, the slope of the measurement compares favorably to the known value for the range as a function of delay which agrees with the expected value of 14.95 cm/ns.

For measurement of the differential delay terms which show up in the two-way transfer scheme, one can use the portable dish in conjunction with a fixed ground station. With a common clock, one can calibrate out these differential delay terms. This is shown in the following analysis in which  $TI(1)$  and  $TI(2)$  are the time interval counter readings at locations 1 and 2 respectively in a two-way time transfer involving locations 1 and 2.

$$TI(1) = \Delta T + u/c(2) + \text{sat.path}(2 \text{ to } 1) + d/c(1)$$

and 
$$TI(2) = -\Delta T + u/c(1) + \text{sat.path}(1 \text{ to } 2) + d/c(2).$$

$\Delta T$  is the time difference of the clocks at 1 and 2,  $u/c$  denotes time delay through the up-conversion at locations 1 or 2, and  $d/c$  denotes the down-conversions.  $\text{Sat.path}$  represents the total signal path delays up to and through the satellite and down for signals going from location 1 to 2 and vice-versa.  $\text{Sat.path}$  includes any delays due to the earth's rotation.  $\Delta T$  can be calculated as

$$\Delta T = \frac{1}{2} \{ [TI(1) - TI(2)] + [u/c(1) - d/c(1)] - [u/c(2) - d/c(2)] + \text{sat.path}(1 \text{ to } 2) - \text{sat.path}(2 \text{ to } 1) \}.$$

If we assume  $\text{sat.path}$  time delays are reciprocal, except for the time difference term due to the earth's rotation, then  $\text{sat.path}(1 \text{ to } 2) = \text{sat.path}(2 \text{ to } 1) + \delta T(\text{rotation})$  and we have

$$\Delta T = \frac{1}{2} \{ [TI(1) - TI(2)] + [u/c(1) - d/c(1)] - [u/c(2) - d/c(2)] + \delta T(\text{rotation}) \}.$$

Now with the two earth stations co-located and using a common clock, then  $\delta T(\text{rotation}) = 0$  and  $\Delta T = 0$  and the difference in the  $u/c$ 's and  $d/c$ 's is explicitly the difference in the time interval counters. We have

$$TI(2) - TI(1) = [u/c(1) - d/c(1)] - [u/c(2) - d/c(2)] = \text{constant}.$$

This constant can be used for subsequent two-way time transfers using the earth stations, one of which is a portable VSAT which can be located with another earth station to yield a "calibration" of that earth station.

In doing two-way time transfer experiments through geostationary satellites, there exists a limit on the knowledge of the time delay difference between the outgoing signal and the received signal. This non-reciprocity is due to the

difference of paths and the difference of equipment between the uplink and the downlink. Using spread spectrum modulation with different pseudorandom codes for the two directions of time transfer, it is common to assume the difference in the transmission paths to and from the satellite as well as through the satellite transponder to be zero and the earth's rotation correction can be computed [5,6]. Certainly the ionospheric dispersion and the effects of water vapor dispersion are small (below 100 ps) [7]. The most significant time delay difference error enters in the ground segment. The use of cables, interconnects, conversions, and test points for instruments creates the most significant absolute delays and thus the opportunity for significant differential delays.

## MEASUREMENT RESULTS

Frequency stability measurements at various carrier-to-noise density ratios are shown in Figure 7. Frequency stability is depicted by  $\sigma_y(\tau)$ , the Allan variance. Short-term data to about 1000 seconds is shown for  $C/N_0$  ratios of 55 dB-Hz, 65 dB-Hz and 75 dB-Hz. In addition, a plot is shown of the theoretical  $\sigma_y$  at 75 dB-Hz given the phase jitter data which is part of the documentation for the modem. Also a plot is shown of the frequency stability obtained when the modem is in a self test mode (the  $C/N_0$  ratio is unknown in this mode but presumed to be high). The modem self-test is the functional equivalent of looping the 70 MHz signal which is transmitted from the modem back and returning the signal to the modem. Long term data of one sample per day is also shown in the plots of Figure 7. For these data, the  $C/N_0$  ratio was preset to 65 dB-Hz. For comparison the extrapolated value of the short term stability line is extended in the case of 65 dB-Hz. Within the confidence limits of the long term data the agreement is good with the extrapolated short term results. The minimum  $C/N_0$  ratio specified for the modem is 50 dB-Hz. From these data one sees that a power density of 75 dB-Hz provides only a factor of 2 improvement in frequency stability compared to 65 dB-Hz. The plots shown in Figure 7 represent the in-cabinet loop-around test configuration which includes all of the ground station equipment and includes the LNA. The modem self test and theoretical  $\sigma_y$  plots do not incorporate any of the ground station RF facilities. From this one sees the degradation introduced by the difference of adding the ground station RF equipment to the loop-around for the modem. Since the difference is small this implies good phase stability throughout the ground station RF system, the main limitation being the modem itself.

Figure 8 shows in-cabinet loop tests which were done on two other modems and three modems in tandem with one of the portable VSATs. These frequency stability results are essentially identical to those shown for the large dish earth station RF equipment (Figure 7). This is encouraging in view of the completely different conversion scheme and oscillators used in the VSATs. In addition these results indicate indiscernible differences among the modems tested and only slight degradation in a 3-way connection. The results of Figure 8 are based on  $C/N_0$  ratio of 75 dB-Hz.

Figure 9 is a plot of the time interval counter reading as a function of running time for a VSAT/modem in both an in-cabinet loop test and a free-space loop test. The difference schematically between the two schemes is shown in Figures 4 and 5. Absolute loop-around time delays are indicated in Figure 9 and show that delay fluctuations are held to less than 1 ns for in-

cabinet tests and 2 ns for free-space tests. One would expect the in-cabinet and free-space tests to be identical. The larger fluctuations associated with the free-space test are likely attributable to the environmental sensitivity of the translator equipment and its associated antennas, cables, and connectors. Also multipath may have been a factor in the free-space test since measurements were taken near ground level and in the antenna near field-region. Data of Figure 9 was taken with a  $C/N_0$  ratio of 65 dB-Hz.

The distance measurement to the satellite simulator is made using the time interval counter (TIC) in conjunction with the modem as shown in Figure 5. A one second pulse starts the counter and simultaneously is transmitted; the received pulse stops the counter. The TIC measurement gives a range (slant range) of

$$r = \frac{\Delta\tau - \tau_c}{2c}$$

where  $c$  is the velocity of light and  $\tau_c$  is the total correction due to the internal delays of the VSAT, the simulator and any additional biases.  $\Delta\tau$  corresponds directly to the slant range. Figure 10 shows the results of these measurements. Even though the apparatus was set up in the near field of the VSAT, the measurements are in close agreement with expected results in which the slope is known to be 14.95 cm/ns. The reference point for distance measurements to the VSAT dish is taken to be the phase center which is the end of the J-hook feed.

Figure 11 shows the scheme involving a common reference clock feeding a 1 pps signal to both the earth station facility modem and the VSAT modem. A transponder (either satellite or satellite simulator) is in common view. Using this scheme the differential-delay terms present in both ground systems can be removed in the two-way time transfer technique as previously described. The VSAT is sufficiently portable that it can be moved to within a short enough distance of any earth station in order to use a common reference for performing the calibration of the differential delays. This common view/common clock scheme was used by the Radio Research Laboratories of Japan to achieve accuracies of 6.3 ns and resolution to 0.74 ns at K-band [8]. We believe that, with the first results presented here, we can improve on this performance. The spread-spectrum equipment was the limiting factor for the RRL as in our work, but the improved spread-spectrum components should yield accuracy to the 1 ns level.

## CONCLUSION

Phase stability measurements on recently acquired ground-segment, satellite equipment have been performed in a variety of loop-around schemes using a satellite simulator. Stability plots have shown that performance is of the order of  $2 \times 10^{-10} \tau^{-1}$  for  $C/N_0$  ratios of 75 dB-Hz. The ultimate limit to performance appears to be the spread-spectrum modems. This performance compares favorably with results expected from the phase jitter of the modem. The day-to-day reproducibility of a free-space, loop-around test involving a 1.8 meter VSAT showed results to slightly better than 1 ns indicating a potential accuracy at this level given an appropriate calibration. Based on these data one should expect accuracy using the two-way time transfer technique to be better than 1 ns given that the involved earth stations can be

calibrated using the VSAT in a common view/common clock scheme. The plan is to complete experiments using the common view/common clock scheme and to complete more thorough free-space loop tests in the far field of the earth station and VSAT. Since the VSAT and its associated cables and connectors are used to "calibrate" an earth station, VSAT stability will be more extensively measured. Both a satellite and satellite transponder will be used for future free-space measurements with the ultimate goal being a verifiable accuracy to the 1 ns level.

#### REFERENCES

- [1] "Earth-Terminal Design Benefits from MMIC Technology," N. Osbrink, MSN & CT, August 1986, pp. 68-77.
- [2] Mitrex 25000 Documentation, Ph. Härtl, et al., Institute for Navigation, University Stuttgart, Germany, January 1985.
- [3] "Characterization of Frequency Stability," J.A. Barnes, et al., IEEE Transactions on I & M, Vol. I-20, no. 2, May 1971, pp. 105-120.
- [4] Private communication, D. Allan, National Bureau of Standards, 325 Broadway, Boulder, CO 80303.
- [5] "Timing by Satellite: Methods, Recent Developments, and Future Experiments," D. Kirchner and W. Riedler, Proc. Int. Symp. on Satellite Transmissions, Graz, Austria, 25-27 September, ESA SP-245 (No. 1985).
- [6] "Practical Implications of Relativity for a Global Coordinate Time Scale," N. Ashby and D. Allan, Radio Science, Vol. 14, no. 4, 1979, pp. 649-669.
- [7] "Atmospheric Absorption and Dispersion of Microwave Signals in the Centimeter and Millimeter Region," H.A.M. Al-Ahmad, H. Smith, E. Vilor, Portsmouth Polytechnic Internal Report No. 84/5, January, 1984.
- [8] "Time Comparison Experiments with Small K-Band Antennas and SSRA Equipments via a Domestic Geostationary Satellite," M. Imae, et al., IEEE Transactions on I & M, Vol. IM-32, no. 1, March 1983, pp. 199-203.

#### FIGURE CAPTIONS

1. Ku-band 6.1 meter antenna (in background) and portable 1.8 meter VSAT.
2. Earth station equipment.
3. Equipment configuration used with 6.1 meter earth station facility.
4. "In-cabinet" test set-up for VSAT (RF unit only) looped through the satellite translator.
5. "Free-space" test set-up for VSAT transmitting and receiving through a satellite simulator located at a distance  $r$ .
6. Plot of white noise phase jitter versus  $C/N_0$  ratio for the spread spectrum modem (taken from Härtl/MITREX documentation) [2].
7. Frequency stability measurements for "in-cabinet" loop-around test of earth station. Modem-only self test measurement and theoretical stability calculated from phase jitter are also shown. Long-term data is slightly worse than straight-line extrapolation of short-term data at 65 dB-Hz.
8. Frequency stability of "in-cabinet" loop tests using two separate modems. The rectangles represent data of three modems in tandem (signal goes through all three in series) and the VSAT and satellite translator.
9. Daily time interval counter (TIC) readings showing total in-cabinet and free-space loop-around time delay reproducibility using VSAT.

10. Time interval counter (TIC) readings as a function of range  $r$ . Slope is exactly expected result and extrapolation to zero is straightforward.
11. Common view/common clock scheme for measurement of ground-segment differential delay constant.

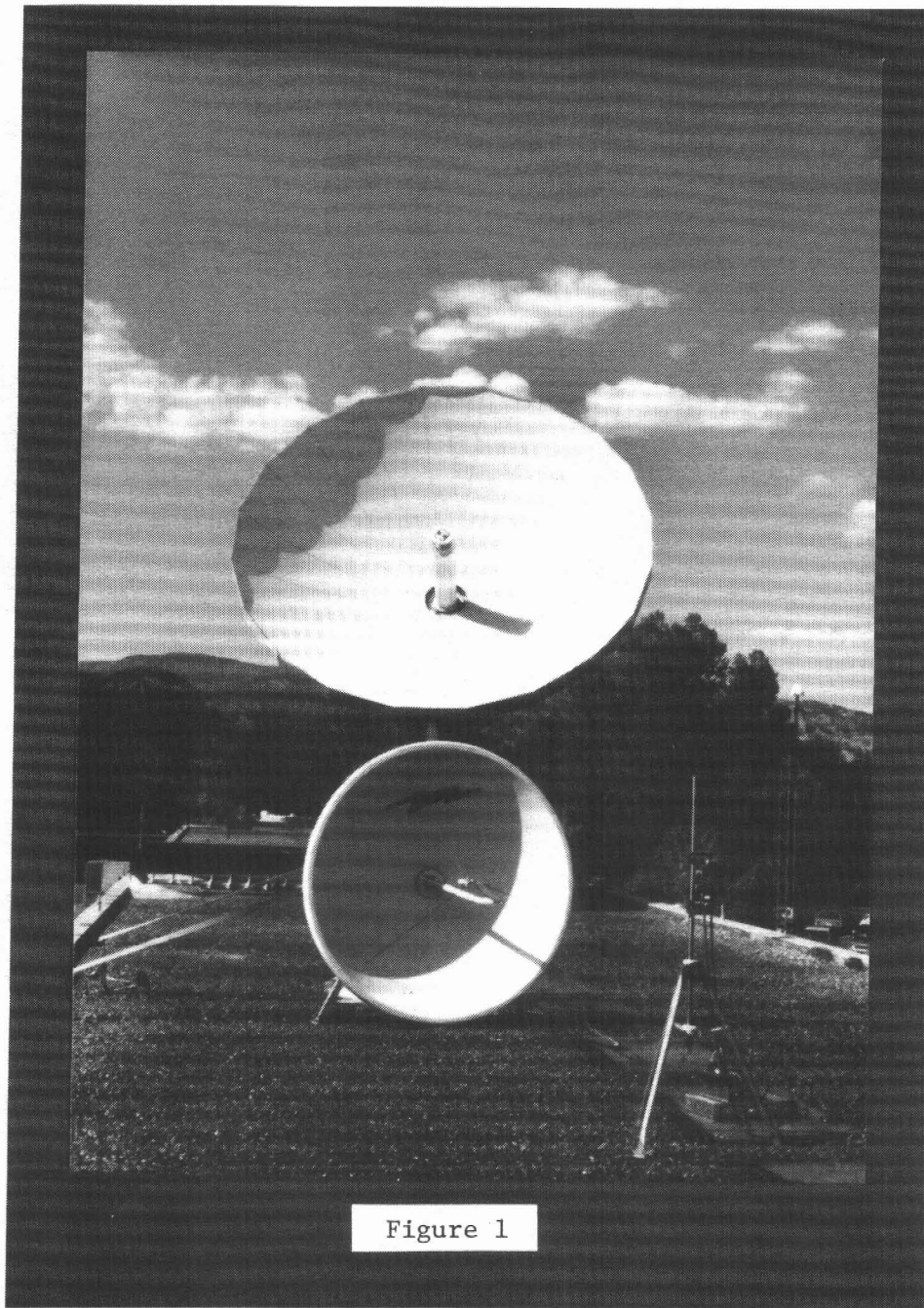

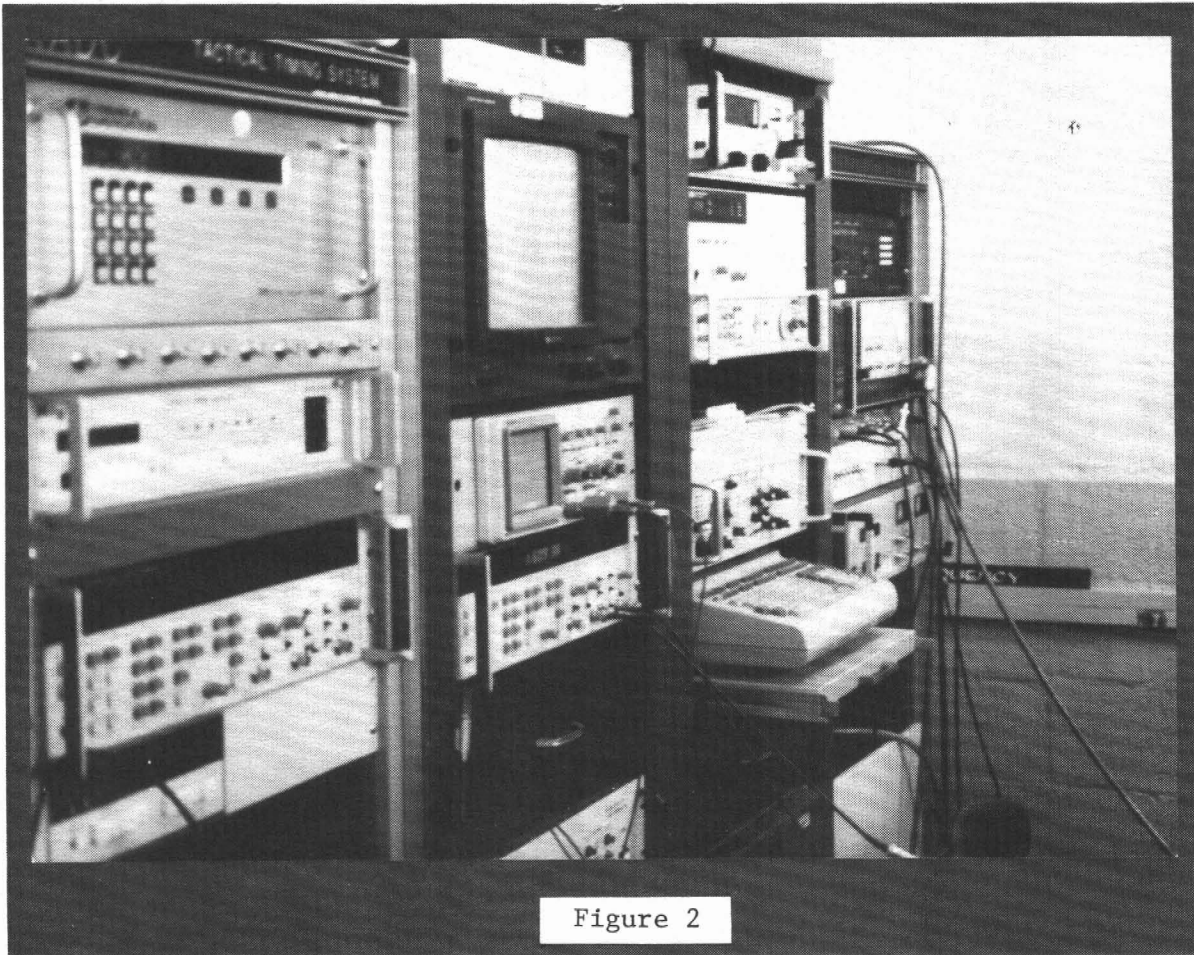

Figure 2

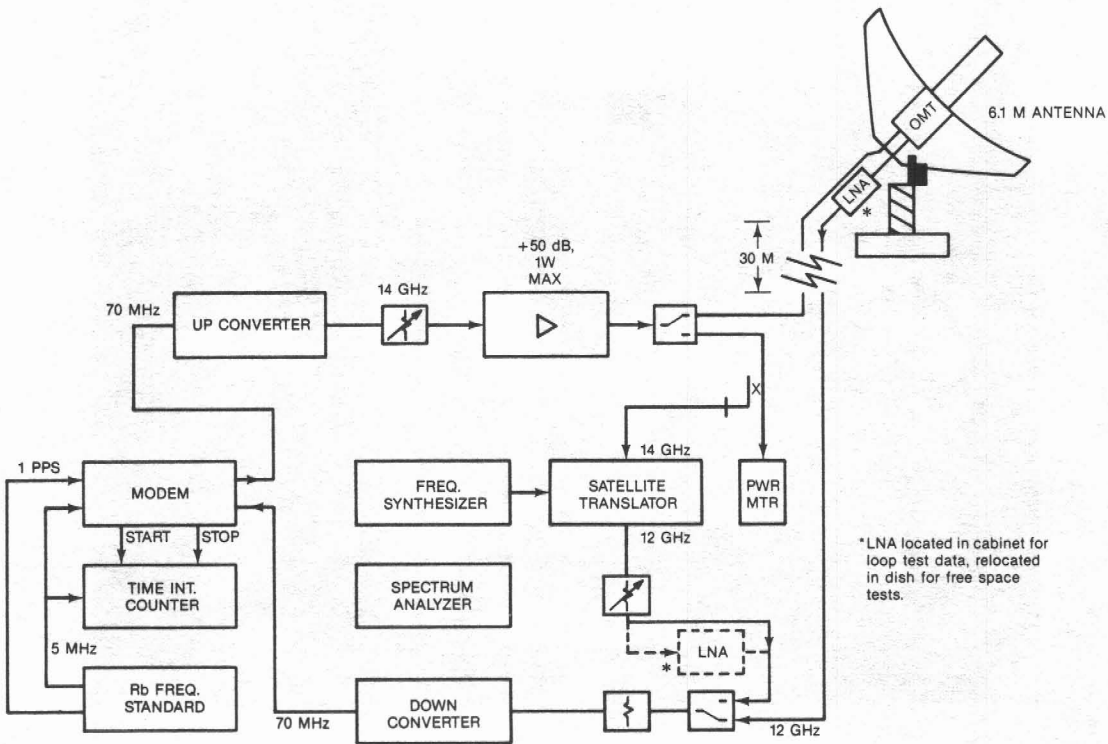

Figure 3

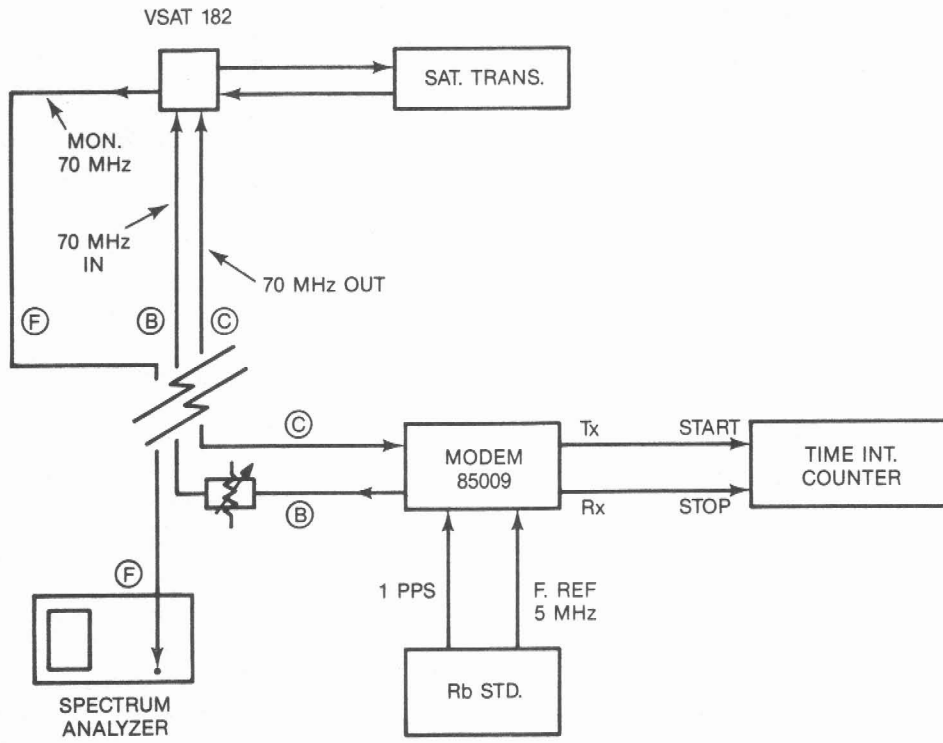

Figure 4

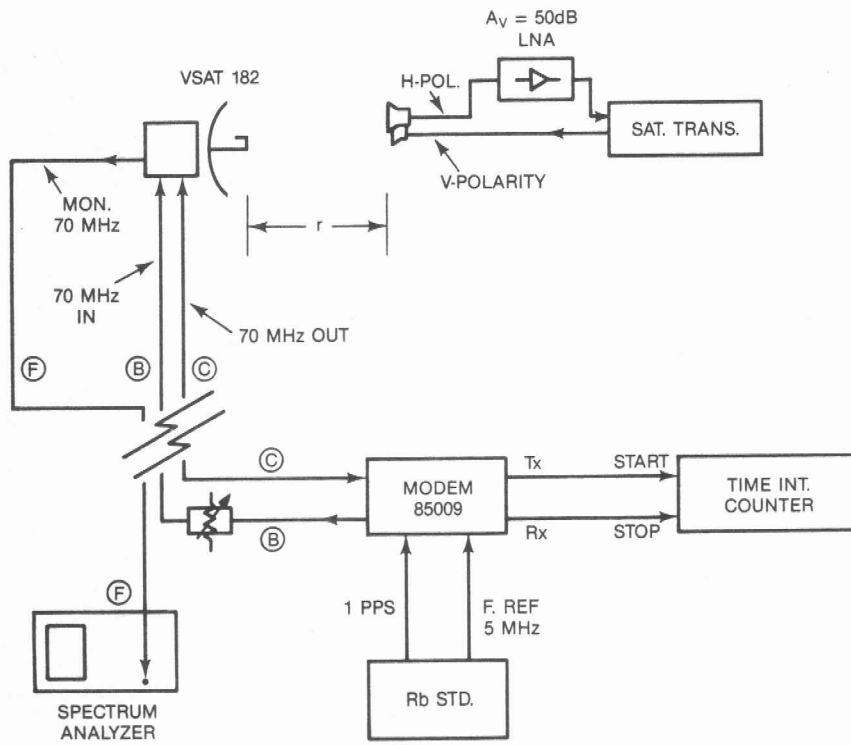

Figure 5

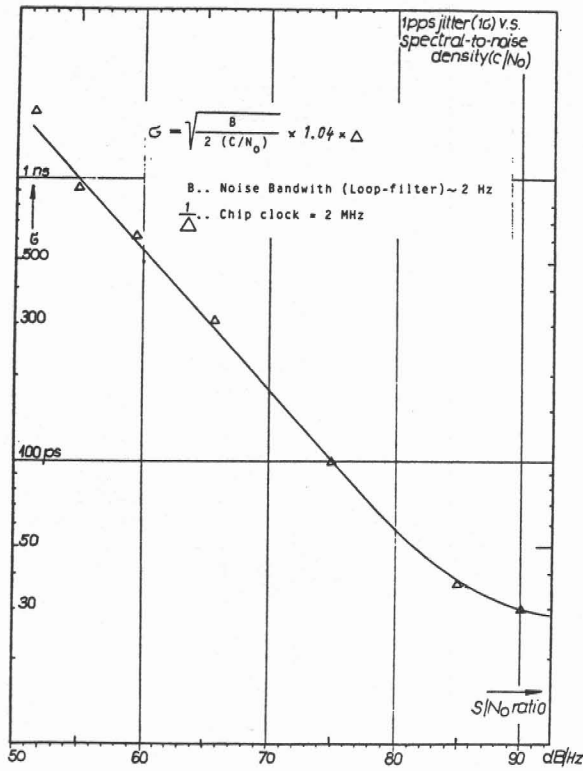

Figure 6

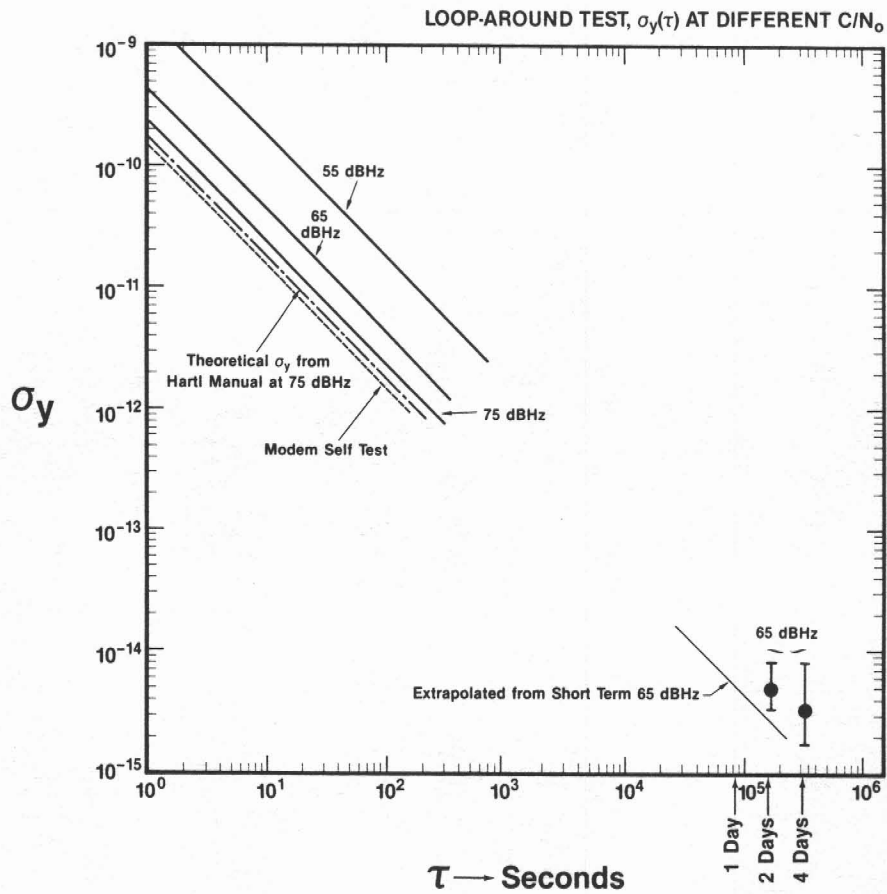

Figure 7

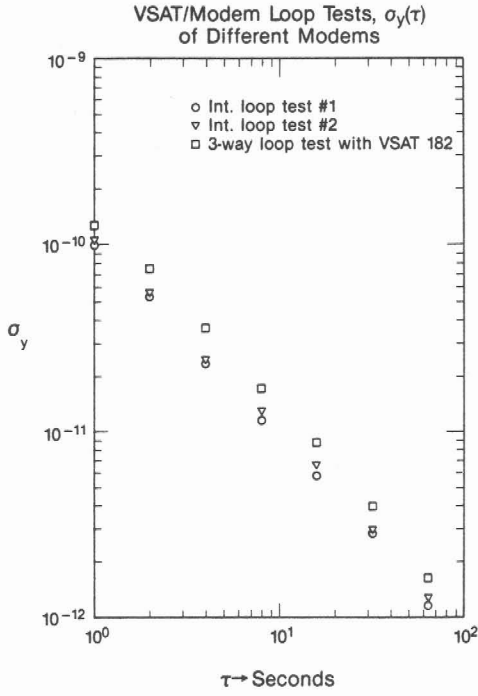

Figure 8

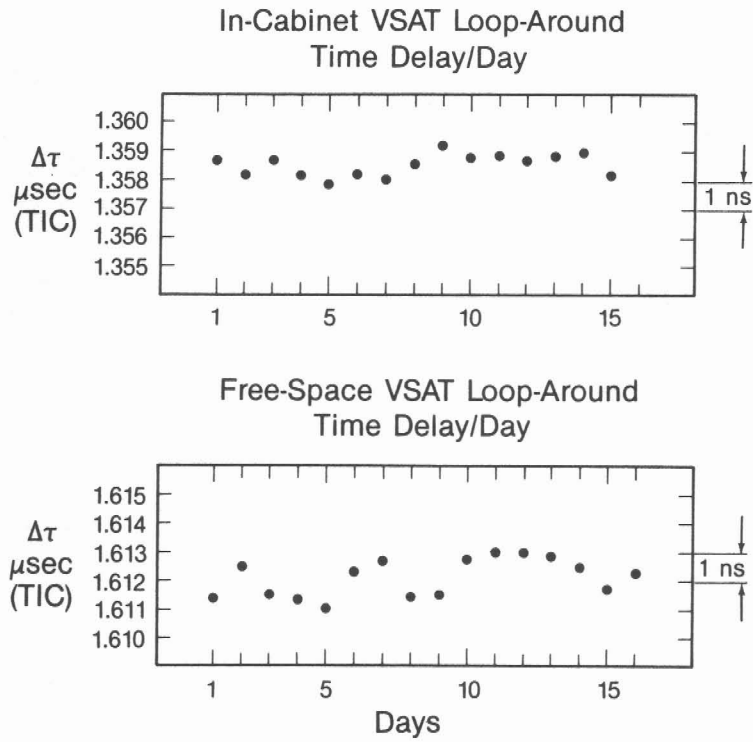

Figure 9

# VSAT Free-Space Range Measurements

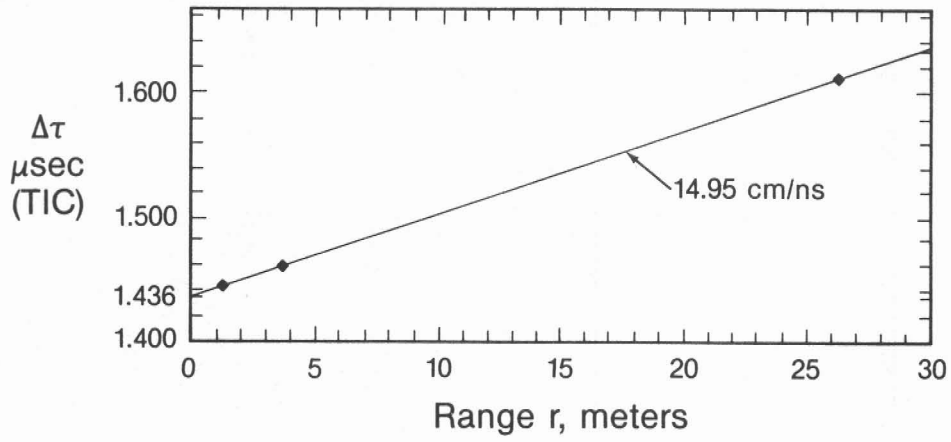

Figure 10

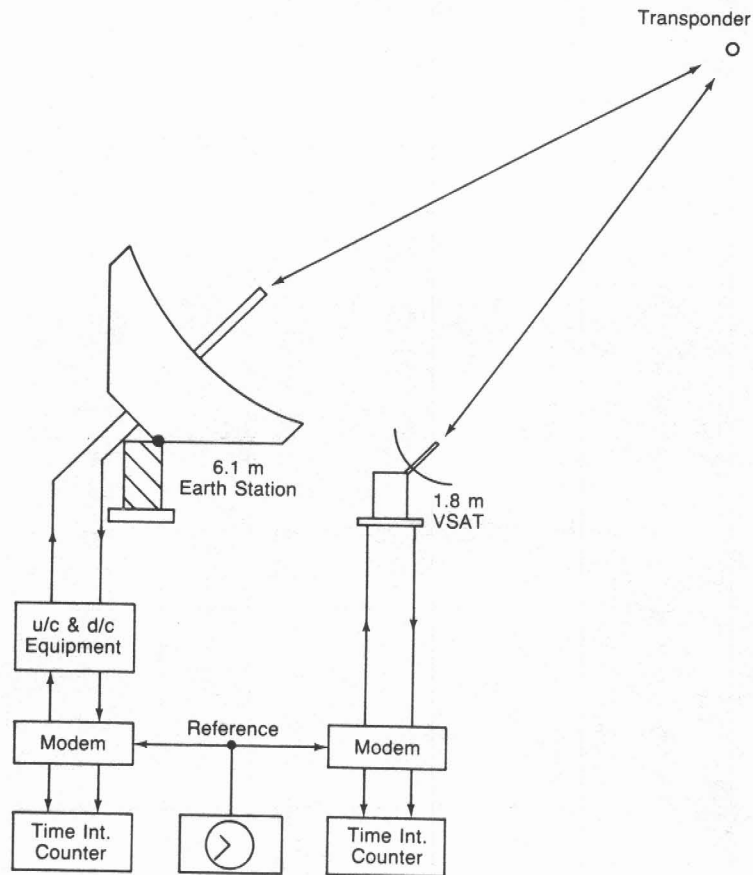

Figure 11

## QUESTIONS AND ANSWERS

GERNOT WINKLER, UNITED STATES NAVAL OBSERVATORY: Don't laugh, but I think that the excess variation which you see in the free space measurement is multipath. You are making these tests on the roof of your building, aren't you? In fact, without an antenna range to do these measurements, it is exceedingly difficult.

MR. HOWE: That's right. I don't know whether I emphasized that or not, but the maximum distance was about 26 meters. That is still in the near field of the antenna. There is ground effect, there could be multipath.

MR. WINKLER: If I may come to a second point, I did not quite understand how much are the differential variations. You said that you know in principle.

MR. HOWE: I agree that the differential delays that are important. Doing a round trip delay measurement and seeing levels at one nanosecond encourages you to look at that level and to consider it as the accumulated effect and the differential delay should be verifiable to the level that you like.