

HIGH PERFORMANCE MAGAZINE CERTIFICATION TEST OF NONPROPAGATION WALLS

Robert N. Murtha
Naval Facilities Engineering Service Center, Port Hueneme, California 93043

Carl Halsey
Naval Air Warfare Center Weapons Division, China Lake, California 93555

Edward M. Jacobs
Integrated Systems Analysts. Inc., Fort Walton Beach, Florida 32547

ABSTRACT

The Naval Facilities Engineering Service Center (NFESC) is developing a new magazine design, named the High Performance (HP) Magazine, for storage of ordnance. The HP Magazine is a partially buried, earth-bermed, 2-story, box-shaped structure. The HP Magazine reduces by at least 80 percent the land encumbered by Explosives Safety Quantity Distance (ESQD) arcs designed to protect people and property from effects of an accidental explosion.

The most important factor in the improved performance of the HP Magazine is the reduction in the Maximum Credible Event (MCE) to a detonation, explosion, or fire involving a small fraction of the explosives stored in the HP Magazine. For example, the explosive storage capacity of the HP Magazine is 300,000 pounds net explosive weight (NEW), but the MCE is no more than 60,000 pounds NEW (total NEW in an open storage cell plus the shipping and receiving area (SRA)). This performance is achieved by utilizing nonpropagation walls (NPW) and pit covers to segregate the ordnance and to prevent sympathetic reaction to closed storage cells.

The HP Magazine Certification Test No. 1 was conducted on 28 June 1995 at the Cactus Flat Test Range, China Lake, CA by the Naval Air Warfare Center Weapons Division (NAWCWPNS) for the following critical storage cell sympathetic detonation hazard scenario:

- Detonation of a 30,000-pound donor of Mk82 bombs in a 38.5-ft x 20-ft x 15.5-ft (LxWxH) storage cell.
- Critical acceptors consisted of thick-case bombs and projectiles and thin-case torpedo warheads and mines placed in 4 adjacent storage cells.

Data acquisition included acceptor response, NPW response, airblast instrumentation, debris recovery, and photography.

All the thick-case acceptors were recovered intact with very minor damage. As predicted, the thin-case acceptors suffered more extensive damage. Typically these acceptors cracked open and their explosive contents reacted by burning, but not detonating. The test results certified the explosives safety performance of the HP Magazine to prevent sympathetic detonation (SD) between ordnance storage cells.

INTRODUCTION

Background

The conceptual design of the current HP Magazine prototype is described in Figures 1, 2, and 3. The HP Magazine is a partially buried, earth-bermed, 2-story, box-shaped concrete structure. Story-1 is partially buried and earth-bermed along all four sides of the concrete structure, to an elevation slightly above the maximum possible elevation of stored ordnance. Story-2 is a conventional, prefabricated

Report Documentation Page

Form Approved
OMB No. 0704-0188

Public reporting burden for the collection of information is estimated to average 1 hour per response, including the time for reviewing instructions, searching existing data sources, gathering and maintaining the data needed, and completing and reviewing the collection of information. Send comments regarding this burden estimate or any other aspect of this collection of information, including suggestions for reducing this burden, to Washington Headquarters Services, Directorate for Information Operations and Reports, 1215 Jefferson Davis Highway, Suite 1204, Arlington VA 22202-4302. Respondents should be aware that notwithstanding any other provision of law, no person shall be subject to a penalty for failing to comply with a collection of information if it does not display a currently valid OMB control number.

| | | | | | |
|---|------------------------------------|---|---|----------------------------------|---------------------------------|
| 1. REPORT DATE AUG 1996 | 2. REPORT TYPE | 3. DATES COVERED 00-00-1996 to 00-00-1996 | | | |
| 4. TITLE AND SUBTITLE High Performance Magazine Certification Test of Nonpropagation Walls | | 5a. CONTRACT NUMBER | | | |
| | | 5b. GRANT NUMBER | | | |
| | | 5c. PROGRAM ELEMENT NUMBER | | | |
| 6. AUTHOR(S) | | 5d. PROJECT NUMBER | | | |
| | | 5e. TASK NUMBER | | | |
| | | 5f. WORK UNIT NUMBER | | | |
| 7. PERFORMING ORGANIZATION NAME(S) AND ADDRESS(ES) Naval Facilities Engineering Service Center, 1100 23rd Avenue, Port Hueneme, CA, 93043 | | 8. PERFORMING ORGANIZATION REPORT NUMBER | | | |
| 9. SPONSORING/MONITORING AGENCY NAME(S) AND ADDRESS(ES) | | 10. SPONSOR/MONITOR'S ACRONYM(S) | | | |
| | | 11. SPONSOR/MONITOR'S REPORT NUMBER(S) | | | |
| 12. DISTRIBUTION/AVAILABILITY STATEMENT Approved for public release; distribution unlimited | | | | | |
| 13. SUPPLEMENTARY NOTES See also ADM000767. Proceedings of the Twenty-Seventh DoD Explosives Safety Seminar Held in Las Vegas, NV on 22-26 August 1996. | | | | | |
| 14. ABSTRACT see report | | | | | |
| 15. SUBJECT TERMS | | | | | |
| 16. SECURITY CLASSIFICATION OF: | | | 17. LIMITATION OF ABSTRACT Same as Report (SAR) | 18. NUMBER OF PAGES 34 | 19a. NAME OF RESPONSIBLE PERSON |
| a. REPORT unclassified | b. ABSTRACT unclassified | c. THIS PAGE unclassified | | | |

building with no earth cover. The HP Magazine reduces by at least 80 percent the land encumbered by ESQD arcs designed to protect people and property from effects of an accidental explosion; reduces by 50 percent the safe standoff distance required from inhabited facilities and property lines; allows noncompatible ordnance to be stored in the same magazine, thereby reducing the number of magazines needed to store a fixed inventory of ordnance; requires a smaller work crew and less equipment and time to store and retrieve ordnance; provides the equivalent of a barricaded siding for temporary storage of ordnance loaded vehicles; improves storage efficiency, selectability, and versatility; and accommodates the broad spectrum of ordnance types (missiles, mines, torpedoes, bombs, bullets and projectiles), ordnance sizes (containerized missiles and palletized conventional ordnance), and hazard classes of Navy ordnance. In general, the HP Magazine provides a better balance between operational requirements, explosives safety regulations, and economic considerations.

The most important factor in the improved performance of the HP Magazine is the reduction in the MCE to a detonation, explosion, or fire involving a small fraction of the total quantity of explosives stored in the HP Magazine. For example, the explosive storage capacity of the HP Magazine is 300,000 pounds net explosive weight (NEW), but the MCE is no more than 60,000 pounds NEW (total NEW in an open storage cell plus the shipping and receiving area (SRA)). This performance is achieved by utilizing nonpropagation walls (NPW) and pit covers to segregate the ordnance and to prevent sympathetic reaction to closed storage cells.

The NFESC has concluded that the HP Magazine is a feasible concept based on results from computer code analysis of MCE detonations and fires inside the HP Magazine, and from explosive tests involving MCE detonations in small-scale structures. In FY93, the NFESC conducted two explosive tests of full-scale storage cells which served to demonstrate the explosives safety performance of the HP Magazine. These tests demonstrated that the nonpropagation cell walls prevented sympathetic detonation to Mk82 bombs and M107-155mm projectiles from Mk82 bombs stored in an adjacent cell. The nonpropagation walls were designed using preliminary SD threshold criteria developed from the test and analysis of thick-case weapons. The tests also verified the procedure for calculating loads, nonpropagation wall response and acceptor ordnance response.

Objectives

Primary Objective. The primary objective of the HP Magazine Certification Test No. 1 (CT1) is to certify that the HP Magazine prototype aisle and cell walls will prevent SD from the critical donor in a storage cell to the critical acceptors in adjacent storage cells. Certification of the nonpropagation aisle and cell wall designs requires the following:

- Relative deformation of thick-case acceptors (i.e., bombs and projectiles) shall not exceed a change in diameter/original diameter ($\Delta D/D$) of 0.25.
- Explosive fill of thick-case acceptors shall not react.
- Explosive fill of thin-case acceptors (i.e., mines and torpedo warheads) may burn but shall not detonate.

Secondary Objectives. Secondary objectives are as follows:

- **Safe Distance Criteria Development.** External pressure and debris data will be gathered to help validate prediction methods for safe pressure and debris distances from accidental detonations. Since the CT1 structure (magazine walls, roof and entrance) differ from the current HP Magazine

prototype design, the data will be obtained to validate prediction methods; not to empirically derive safe distance criteria for the prototype HP Magazine.

- Validation of Acceptor Response Predictions. Acceptor deformation and acceleration data will be used to evaluate the test load environment in the acceptor cells and to validate prediction methods (AUTODYN and DYNA3D models) for loads and acceptor response. Wall velocity data will also be used to validate prediction methods.

Scope

To certify nonpropagation, CT1 is an explosive test of the internal nonpropagation transfer aisle and cell walls for the following critical storage cell SD hazard scenario:

- Detonation of a 30,000-lb donor of Mk82 bombs in a 38.5-ft x 20-ft x 15.5-ft (LxWxH) storage cell.
- Critical acceptors from HP Magazine Storage Groups 4 (i.e., thick-case bombs and projectiles) and 8 (i.e., thin-case torpedo warheads and mines) will be placed in 4 adjacent storage cells.

The test setup (including details of the test site, test structure, ordnance configuration, and data acquisition) are described in the next section. Additional pretest information can be found in the Test Plan for HP Magazine Experimental Certification Test No. 1 (Reference 1).

TEST SETUP

Test Site

The test was conducted at the Cactus Flat Test Range, China Lake, CA by NAWCWPNS. The site layout is shown in Figure 4. A 200-ft radius was cleared around the CT1 structure to facilitate construction. Soil within this area was used to berm the structure. Three 10-ft wide strips were cleared of vegetation and leveled (with a blade) to a range of 1,600 ft from the structure for three pressure gauge lines opposite the front, rear, and side walls.

Test Structure

Because of recent improvements in the HP Magazine concept (adopted too late to be incorporated in CT1), the external surfaces (i.e., walls and roof) and tunnel entrance of the CT1 structure are not representative of the current (June 1995) HP Magazine prototype concept. For example, the HP Magazine prototype does not have a tunnel entrance and will have lighter wall and roof construction (because it will not be designed to support earth cover). However, the critical interior nonpropagation walls and floor plan of the CT1 structure are representative of the HP Magazine prototype concept. The current prototype design is less expensive and will vent gas pressure more quickly than the CT1 structure. The more confining external envelope of the CT1 structure will produce conservative loads for certifying the HP Magazine nonpropagation aisle and cell walls.

External CT1 Structure. The CT1 structure is a full-scale reinforced-concrete representation of one half (right half) of the HP Magazine prototype storage area. The CT1 structure does not include the

prototype SRA and the left half of the storage area. This smaller total internal volume and heavier wall and roof construction will produce conservative test loads. The CT1 structure was designed by SOH&A Structural Engineers, San Francisco, from an NFESC Basis of Design (Reference 2). Design details can be obtained from the final SOH&A drawings and specifications (Reference 3).

The plan view and cross-sections of the external envelope of the CT1 structure are shown in Figures 5 through 9. The interior dimensions of the structure are 85 ft x 50 ft-6 in. x 28 ft-3 in. (LxWxH). The section views in Figures 6, 7, and 8 show elevation views along the length and width of the structure. The earth berm elevation is 18 ft-6 in. (i.e., 3 ft above the storage area height). Figure 8 shows the tunnel entrance. The roof plan is shown in Figure 9. The major support girders span 50 ft-6 in. along Lines 2 through 7. Initially, beams on Lines B, C, and D were required to support the full-height earth cover of the original design (i.e., required unit weight of the original concrete and soil cover roof system must be 970 pcf). However, since there is no earth cover over the final CT1 structure, 12 roof panels were left out of the structure roof diaphragm to allow access (by crane) for placement of the interior walls, donors, acceptors, and pit covers. The absence of these panels also provided better air circulation during construction and reduced the containment of gas pressure test loads to more accurately model the HP Magazine prototype design loads. Photographs of the completed CT1 structure are shown in Figures 10 and 11.

Interior Nonpropagation Walls. The interior aisle and cell walls of the CT1 structure were also designed by SOH&A (Reference 4) from an NFESC Basis of Design (Reference 5). These walls must prevent propagation of a detonation from the donor cell to adjacent acceptor cells. The specific cross-sections of these walls were given to SOH&A by NFESC. The cross-section of the cell wall was used previously in successful full-scale SD cell wall tests in which the acceptor ordnance was oriented perpendicular to the wall. The acceptor ordnance in CT1 is oriented parallel to the aisle wall. In this direction, the acceptors are more easily damaged than those oriented parallel to a wall. Therefore, the aisle wall cross-section was increased to help mitigate the acceptor loading environment. The nonpropagation walls consist of a crushable shock-absorbing, highly porous, lightweight concrete exterior containment shell with a massive internal granular fill. The heavy core fill is used to reduce the kinetic energy of the wall on impact with the acceptor, while the lightweight concrete absorbs strain energy, reduces kinetic energy, and provides thermal insulation to mitigate acceptor loads from the design hazard scenarios. The selected lightweight concrete was the SA/CBC MBW-60 formulation of a shock attenuating chemically bonded ceramic. This material, referred to as CBC in this report, had previously been developed by CEMCOM Research Associates, Inc. to U.S. Navy specifications and characterized in Reference 6 for the HP Magazine nonpropagation walls. The material properties of the CBC are summarized below:

| Material Parameter | Value |
|------------------------------|-------------|
| Density, g | 58-62 pcf |
| Porosity | 50% |
| Compressive Strength, f_c' | 2500 psi |
| Dynamic Strain Capacity* | 60% |
| Splitting Tensile Strength | 250 psi |
| Rebar Bond Strength | 600 psi |
| Elastic Modulus, E | 800,000 psi |

* Occurs at nearly constant crushing strength of f_c'

A plan view and sections of the CT1 nonpropagation walls are shown in Figures 5 through 8. The walls were built from precast, wire mesh reinforced, CBC hollow blocks which were stacked and then filled on-site with a heavy core fill (steel grit or sand). The blocks were manufactured in a precasting facility in Thompson, Ohio. The mixer consisted of a 1cubic yard off center tub mixer with a central discharge. To achieve flow of the CBC into the 1.5-inch-thick webs, the forms were mounted on low frequency oscillating tables for the casting. The demolded blocks were cured under a water mist for 48 hours before finishing. Each CBC block had 18-in.-thick walls parallel to the acceptors and thin structural webs in the depth of the wall. The HP Magazine prototype aisle wall cross-section (8-ft total thickness) for mitigating the conventional 30,000-lb donor load is 3 ft of CBC (18 in. per each block face) and 5 ft of steel grit fill (SAE size S170; density = 285 pcf \pm 10 pcf). The cross-section (5 ft-8 in. total thickness) of the HP Magazine prototype cell wall is 3 ft of CBC and 2 ft-8 in. of steel grit. However, in CT1, only the walls around the donor are required to prevent SD from the donor to acceptors in Cells A1, A2, A3 and A4. The walls between Cells A1 & A4, A2 & A3 and A1 & A2 must only prevent SD between low explosive weight acceptors (in the event that there is SD to one acceptor). Therefore, the walls separating acceptors were filled with lower weight sand (density = 105 pcf \pm 5 pcf). Also, since the height of the CT1 donor and acceptor stacks were less than 10 ft, only the first 10 ft of elevation of the donor walls were filled with steel grit with the top 5 ft-6 in. filled with sand. Figure 5 shows the fill material of each wall. A photograph of a portion of the aisle wall is shown in Figure 12.

Nonpropagation Wall Liners. Solid 18-in.-thick x 15-ft-high precast CBC wall liners, with wire mesh reinforcement, were used to absorb impact loads between acceptors and the exterior walls of the CT1 structure. Figures 5 through 8 show the locations of these CBC wall liners.

Pit Cover. The pit cover is primarily required in the HP Magazine to prevent SD during aisle transport and temporary ordnance storage. The pit cover increases design loads on the acceptors by confining the gas pressure loads and increasing the nonpropagation wall loads. It was therefore necessary to provide a pit cover in CT1 that modeled the HP Magazine prototype pit cover weight. This was done in CT1 by placing 9 inches of loose sand on a timber joist and plywood decking system. Design details can be obtained from the final NFESC drawings (Reference 7). This sand/wood system provided a total pit cover weight of about 100 psf.

Donor Ordnance

The CT1 donor is the critical HP Magazine storage cell donor for the design of nonpropagation aisle and cell walls. The critical loads come from the maximum design storage density of Mk series bombs (30,000 lb = Net Explosive Weight (nominal) in a 38 ft-6 in. x 20 ft (LxW) cell). The high charge weight in a relatively small cell produces the highest design aisle and cell wall loads and the critical environment on the acceptors. The CT1 donor was 144 (24 pallets) tritonal-filled Mk82 bombs with a total NEW of 27,648 lb. Figure 13 shows the CT1 donor stowage plan for Cell D. A photograph of the donor ordnance is shown in Figure 14.

Acceptor Ordnance

Worst Case Acceptors. The worst case acceptor ordnance from all the HP Magazine Storage Groups (SG's) were tested in CT1. The worst case acceptors come from SG 4 (thick-case bombs and projectiles) and SG 8 (thin-case mines, torpedoes and missiles). The worst case SG 4 acceptors to be tested were the general purpose Mk82 and Mk83 bombs, and the M107-155mm projectiles. The worst

case SG 8 acceptors to be tested were the Mk107 warheads for the Mk46 torpedoes, Mk103 warheads for the Mk48 torpedoes, and the Mk55 mines. Items of each acceptor were located in two cells (one cell opposite the aisle wall and one cell opposite the cell wall). They were stowed in the orientation consistent with the HP Magazine stowage plans (e.g., the Mk series bombs were stored parallel to the aisle wall and perpendicular to the cell wall).

An inert Mk82 bomb was placed in the same location in every acceptor cell for post-test analysis of the load environment.

Acceptor Stowage Plans. The overall acceptor stowage plan for CT1 is shown in Table 1 and Figure 13. Where possible (generally Cells A1 and A2) the spacing of acceptors from nonpropagation walls was the same as in the HP Magazine stowage plan. However, because Cells A3 and A4 were undersized, the HP Magazine stowage plan spacings could not be maintained. The acceptors in these cells were conservatively placed closer to the cell wall than would be the case in the prototype HP Magazine. The stowage plan for each acceptor cell is as follows:

- **Cell A1.** This cell tested SG 8 acceptors (Mk55 mines and Mk103 & Mk107 torpedo warheads) opposite an aisle wall. All acceptors were oriented parallel to the aisle wall. A photograph of the ordnance in Cell A1 is shown in Figure 15.
- **Cell A2.** This cell tested SG 4 acceptors (Mk82 and Mk83 bombs) opposite an aisle wall. All acceptors were oriented parallel to the aisle wall. Since the M107-155mm projectiles are considered more critical opposite a cell wall and since they are a recovery hazard, they were not placed in Cell A2. A photograph of the ordnance in Cell A2 is shown in Figure 16.
- **Cell A3.** This cell tested SG 4 acceptors (Mk82 and Mk83 bombs, and M107-155mm projectiles) opposite a cell wall. The bombs were oriented perpendicular to the cell wall. The M107-155mm projectiles, which are stored vertically, were therefore parallel to the cell wall. Since the loading environment behind a cell wall is greater than behind an aisle wall (and the M107 projectile is parallel to both), Cell A3 was considered more critical than Cell A2. A photograph of the ordnance in Cell A3 is shown in Figure 17.
- **Cell A4.** This cell tested SG 8 acceptors (Mk55 mines and Mk103 and Mk107 torpedo warheads) opposite a cell wall. The Mk55 mines and Mk107 torpedo warheads were oriented perpendicular to the cell wall. The M103 torpedo warheads, which are stored vertically, were therefore parallel to the cell wall. Five live and three inert instrumented M107-155mm projectiles were located in Cell A4 for post-test evaluation of acceptor loading and response. A photograph of the ordnance in Cell A4 is shown in Figure 18.

Data Acquisition

Acceptor Response: Measured. The primary post-test response analysis was made by visual inspection and measurement of acceptor deformations. The measured deformations were compared with predictions and the design criteria allowables. One inert Mk82 was placed at the same location (i.e., height and setback from nonpropagation wall) in each acceptor cell. Their deformations were compared with DYNA3D predictions of deformation versus wall momentum to evaluate the donor loads on each wall and the environment in each cell. Three 155mm projectiles located in Cell A4 were each instrumented with two accelerometer-gaged HDAS¹ recorders by the US Army Corps of Engineers

¹ Hardened Data Acquisition System

Waterways Experiment Station (WES). The accelerometer data from these projectiles were compared with predicted values and previous experimental data to determine the acceptor loads in Cell A4.

Acceptor Response: Sympathetic Reaction Determination. For each acceptor ordnance not recovered intact, a determination of reaction occurrence was made. If a reaction occurred it was further characterized as a burn, explosion, or detonation. Reactions were evaluated by the condition of the acceptor casing (crushed, scorched, and presence and pattern of case fragments), floor cratering in the CT1 structure, exterior wall response of the CT1 structure (including fragment damage and patterns), and the presence of unburned explosives. External pressure and ground shock gage readings were evaluated for indications of independent (in time) detonations, uneven pressure vs. range along the three gage lines (located at 90° intervals), and for greater pressure or ground shock than expected from the donor alone.

Nonpropagation Wall Response. The cell wall between Cells A4 and D was instrumented at two locations with accelerometer-gaged HDAS recorders. The accelerometer data were compared with predicted values and previous experimental data to determine the acceptor loads in Cell A4.

Airblast. Three lines of side-on self-contained HDAS pressure gages were used to measure the airblast pressure versus range and azimuth. Since the test setup was not symmetrical, gages were placed on the following three gage lines as shown in Figure 4:

- Line (opposite the front of the CT1 structure)
- Line (opposite the rear of the CT1 structure)
- Line (opposite the side of the CT1 structure)

Four gages were located on each line at ranges that provided an accurate relationship for establishing the safe Inhabited Building Distance (i.e., 1.2 psi range). The following table shows the gage locations on each line in relationship to (a) the outside face of the CT1 structure's exterior walls and (b) the center of gravity (c.g.) of the donor charge.

| Gage No. | Location | | |
|----------|------------------|----------------------|---|
| | Azimuth (Degree) | Range from Wall (ft) | Range from Donor c.g. R _z (ft) |
| F-1 | Front (0°) | 620 | 631.0 |
| F-2 | | 930 | 941.0 |
| F-3 | | 1240 | 1251.0 |
| F-4 | | 1550 | 1561.0 |
| B-1 | Back (180°) | 620 | 661.5 |
| B-2 | | 930 | 971.5 |
| B-3 | | 1240 | 1281.5 |
| B-4 | | 1550 | 1591.5 |
| S-1 | Side (270°) | 620 | 663.5 |
| S-2 | | 930 | 973.5 |
| S-3 | | 1240 | 1283.5 |
| S-4 | | 1550 | 1593.5 |

These distances are the actual values at the test site altitude of 5,000 ft above sea level. The values will later be adjusted to sea level conditions.

Ground Shock. Self-contained HDAS acceleration gages were used to determine the ground shock history at three locations (one on each pressure gage line). Each gage was located 100 ft from the c.g. of the donor. This range was chosen to produce approximately 5g's peak acceleration. The ground shock data was used to aid in validating acceptor response.

Debris Recovery. Debris was recovered and characterized by Bakhtar Associates with assistance from a small NAWCWPNS crew under the supervision of the NAWCWPNS Site Coordinator (Carl Halsey). The pick-up zones and procedures outlined in this section were chosen to determine the safe debris distance criteria (for the test conditions) and to validate prediction procedures. The safe debris range is defined as the distance beyond which the hazardous debris density is less than 1 per 600 ft² [Note: hazardous debris = debris weighing at least 134 grams (2-in. diameter concrete or 1-in. diameter steel)]. After a post-test visual inspection of the debris distribution, the three 10° areas (as shown in Figure 4) emanating from the CT1 structure in the 0° (front/north), 180° (rear/south), and 270° (side/west) azimuths were chosen for debris recovery. The collection zones extended out to 3,000 ft for the 0° azimuth, and 2,000 ft for both the 180° and 270° azimuths.

Post-test access was controlled by the Site Coordinator. When access was allowed, area sweep teams flagged debris locations within the 10° zones. Reflector teams marked the debris locations (with a mirror) for surveying the range and azimuth. The reflector team also indicated the debris type (concrete, steel rebar, or CBC) to the recorder. The automated mapping technique developed for the Air Force, Explosion Hazard Reduction Program - EHR, was employed for debris recovery and mapping. The analysis of the field data, debris density and hazard criterion, was performed based on the methodology proposed in Reference 8.

Photographic. Photographic coverage was provided by NAWCWPNS, China Lake. Coverage included:

- Pre-test and post-test photographs and video tape (including construction)
- Four video cameras during the test
- One high-speed 16mm motion picture camera during the test

TEST RESULTS

The test was conducted on 28 June 1995. All 144 Mk82 donor bombs were successfully detonated. A 3-shot sequence of far-away photographs of the test is shown in Figures 19, 20, and 21. The photograph in Figure 21 was taken several minutes after detonation and shows smoke from the burning of some of the thin-case acceptors. Although this burning phase lasted for about 35 minutes, there were no signs of any detonations of acceptors. Closer views of the interior damage to the CT1 structure are shown in Figures 22 and 23. These two photographs show the exterior walls resting against the soil berm after separating from the footing and lifting up from 5 to 10 feet. Almost all of the acceptor ordnance (except some ordnance in Cell A4) was found within or nearby the boundary of the original structure. Six thin-case acceptors from Cell A4 were found along the 90° azimuth between 40 and 550 feet from the structure. All the thick-case projectiles from Cell A4 were found along the 0° azimuth between 130 and 300 feet from the structure.

Airblast Data

Reference 9 contains the digitized external pressure data recorded at the test site altitude of 5,000 ft above sea level. Impulses were obtained by numerically integrating the data. A 9500 Hz low-pass filter was applied to the pressure data. The data are referenced to a common zero time (Time of Detonation) and are displayed with time in milliseconds on the abscissa and the data output on the ordinate. A typical data record is shown in Figure 24. The values of the measured peak pressures at altitude are listed in Table 2. However, in order to compare this data with the results from analytical prediction models, the data was converted to sea level conditions using a computational procedure outlined in Reference 9. These adjusted measured peak pressures and their ranges are listed in Table 3.

For the previous earth-covered HP Magazine prototypes, the external airblast pressures consisted of two components: (1) directional leakage pressure from the tunnel exit, and (2) leakage pressure through the breached roof and soil cover. However, the CT1 structure has a partially open roof with no soil cover. Therefore, even though the CT1 structure has a tunnel exit, the leakage component through this tunnel exit (in any direction) is assumed to be negligible compared to the pressure component through the breached structure. Thus, the predicted peak pressures outside the CT1 structure are based on the equations found in Reference 10 for a hemispherical surface burst of 30,000 lb NEW of TNT. The predicted peak pressures at sea level conditions are shown in Table 3 for all the pressure gage stations. These predictions are plotted versus range as a single line in Figure 25. The measured external peak pressures listed in Table 3 are also plotted in Figure 25 and are all less than predicted. Thus, there is no indication that the magnitude of the explosion exceeded the planned 30,000 lb NEW donor charge. Also, the shapes of all the measured pressure time-histories are representative of a single pulse with a positive and negative phase. There was no evidence of multiple explosions such as multiple peak pressures or a series of completely separate blast loads.

Debris Data

Figure 26 represents the overall debris distribution in polar coordinates around the center of the CT1 structure within the three 10° sectors surveyed. From this figure, it can be seen that ranges for hazardous distances are greater in the front (0°) direction, along the entrance to the structure. Also, debris distribution is fairly uniform around the 0°, 180°, and 270° azimuths.

The U.S. DOD and Navy Explosives Safety Standards (References 11 & 12) criterion for debris hazard range is the farthest distance to a debris density of one hazardous particle per 600 ft². All the debris recovered within the three 10° sectors are considered lethal and hazardous. The technique proposed by Jacobs is used for analysis and interpretation of the hazardous debris density. The Jacob's method is illustrated in Figure 27. According to the Jacob's method, a sector of the annulus of length "*d*" (100 ft in this analysis) was moved away from ground zero (GZ) in increments of "*i*" (20 ft in this analysis). The analysis was started at distance "*a*", representing the inner border in the closed-in region where 100% debris recovery was initiated. For each increment, the area of the sector was calculated, the number of debris in the sector was counted, and the number of debris per 600 ft² was determined. This process was continued until the farthest debris (distance "*b*") was included in the debris-distance calculations. The distance from GZ to the center of the sector of the annulus is the distance reported for the hazardous debris density. An example of the debris areal distributions for CT1, as collected in the front sector, is listed in Tables 4. The debris densities for all three directions are graphically shown in Figures 28, 29, and 30. In order to determine the quantity-distance (Q-D) a curve fitting technique based on an exponential function with a generalized form given by:

$$f(x) = ae^{bx}$$

was used. For such statistical analysis, values of constants are calculated so that the sum of the square of the errors given by $[g(x_i) - \ln(y_i)]^2$ is minimized. The statistical fit and corresponding square of the correlation factor for each set of data from the three sectors are shown by the inserted equations $f(x)$ and R^2 in Figures 28, 29, and 30. From these equations, the Q-D values defining the hazard criterion in the three debris recovery sectors were calculated as:

- Front Sector (0°): D = 2,190 ft
- Back Sector (180°): D = 1,320 ft
- Side Sector (270°): D = 1,475 ft

The safe debris range for the actual HP Magazine prototype should be considerably less than these values because Story-2 will be a conventional, prefabricated building. Thus, the amount of potential debris from both Story-1 and Story-2 has been minimized.

Acceptor Response

All of the thick-case acceptors were recovered intact following the test. Visible damage to these acceptors was minor and limited to scarring of some cases and shearing off of several lifting lugs. A photograph of the ordnance in Cell A3 is shown in Figure 31. These bombs were resting on the remains of the soil berm behind the CT1 structure's sidewall. Pre-test predicted deformations (100 x diameter change /original diameter) for these acceptors ranged from 23-30 percent. These values exceeded the 25 percent threshold established from previous flyer plate tests. However, since the predicted procedure has been consistently conservative from previous tests, it was expected that actual deformations would not exceed the 25 percent threshold. Pre-test predicted pressures of the explosive fill were less than 3 Kbar (threshold = 4 Kbar).

As predicted, the thin-case acceptors suffered more extensive damage. Typically these acceptors cracked open, but any reaction of their explosive contents was limited to burning, not detonating. Pre-test predicted case deformations ranged from 24-35 percent. Based on flyer plate tests of the Mk107 torpedo warhead, casing ruptured at 10 percent deformations. However, detonations were not expected because predicted explosive fill pressures never exceeded 3 Kbar. A photograph of a broken Mk103 torpedo warhead and some unburned PBXN-103 explosive fill from Cell A4 is shown in Figure 32. This warhead was recovered outside the structure. A photograph of a badly burned Mk103 torpedo warhead from Cell A1 is shown in Figure 33. This warhead was found resting against the base of the rear wall CBC liner. A photograph of two burned Mk 55 mines from Cell A4 is shown in Figure 34. Photographs of the two recovered Mk55 mines from Cell A1 are shown in Figures 35 and 36. These mines were both partially buried under the structure rubble. A photograph of a recovered Mk107 torpedo warhead from Cell A1 is shown in Figure 37. It also was partially buried under the structure rubble.

CONCLUSIONS

The nonpropagation interior walls of the CT1 structure prevented sympathetic detonation between the ordnance stored in the donor cell and the ordnance stored in the four acceptor cells. These massive but energy absorbing walls successfully reduced the deformations of the cases and the peak shock pressures of the explosive fill below threshold values. In the future HP Magazine Certification Test No. 3 (to certify explosive safety of the prototype design for the MCE detonation in the SRA), the mass of the nonpropagation aisle wall has been reduced by 30 percent (from 5 ft of steel grit fill to 9 ft of sand fill).

It is concluded that the HP Magazine concept can mitigate the fragment and debris hazard and that the required safe pressure and debris hazard ranges will significantly reduce the total area encumbered by ESQD arcs.

REFERENCES

1. Naval Facilities Engineering Service Center. Site Specific Report SSR-2127-SHR: Test Plan for High Performance Magazine Experimental Certification Test No. 1, by J. E. Tancreto and R. N. Murtha, Port Hueneme, CA, June 1995.
2. Naval Facilities Engineering Service Center. Technical Memorandum TM-2006-SHR: Basis of Design for Certification Test Structure No. 1 for High Performance Magazine Phase 1, by W. A. Keenan, J. E. Tancreto, R. N. Murtha, and K. E. Hager, Port Hueneme, CA, November 1993.
3. NAVFAC Drawing Nos. 6411341 - 6411350. Certification Test Structure No. 1, High Performance Magazine: Phase I Drawings and Specifications, by SOH & Associates, Structural Engineers, San Francisco, CA, 15 June 94.
4. NAVFAC Drawing Nos. 6227134 - 6227138. Certification Test Structure No. 1, High Performance Magazine: Internal NonPropagation Walls, Drawings and Specifications, by SOH & Associates, Structural Engineers, San Francisco, CA, 25 October 1994.
5. Naval Facilities Engineering Service Center. Technical Memorandum: Basis of Design for Internal NonPropagation Walls in HPM Full Scale Certification Test Structure No. 1 (Draft 2), by J. E. Tancreto, K. E. Hager, R. N. Murtha, and W. A. Keenan, Port Hueneme, CA, June 1994.
6. CEMCOM Contract Report submitted to Naval Facilities Engineering Service Center: Development of Structural Shock Absorbing Cement Based Materials for Magazine Construction, by Claudio Herzfeld and Sean Wise, CEMCOM Research Associates, Inc., Baltimore, MD, January 1995.
7. NFESC Drawing No. 94080001. Certification Test Structure No. 1, High Performance Magazine: Pit Cover Drawing by NFESC, Port Hueneme, CA, March 1995.
8. "Determining Hazardous Fragment Separation Distance", by Edward M. Jacobs and Joseph Jenus. Twenty-Sixth DOD Explosives Safety Seminar, Miami, FL, 16-18 August 1994.
9. Naval Facilities Engineering Service Center. Technical Memorandum (to be published): Test Report for High Performance Magazine Certification Test No. 1, by Robert N. Murtha, Port Hueneme, CA.
10. U.S. Army Ballistics Research Laboratory. Technical Report ARBRL-TR-02555: Airblast Parameters from TNT Spherical Air Burst and Hemispherical Surface Burst, by C. Kingery and G. Bulmash. Aberdeen, MD, 1984.
11. DOD 6055.9-STD: Ammunition and Explosives Safety Standards.
12. NAVSEA OP 5 Volume 1: Ammunition and Explosives Ashore Safety Regulations for Handling, Storing, Production, Renovation and Shipping, 6th Revision, 1 March 1995.

Table 1. Acceptor stowage plan.

| Cell | Acceptor | | | | | | | | | Cell NEW (lb) |
|------|-------------|------------------|--------------------|-----------------|--------------------------|------------------------------------|-------------------------|---------------------------|-------------|---------------------|
| | Designation | | Explosive | HPM | Orientation ^b | Number of Units ^c | Number of Weapons | NEW per Weapon (lb) | NEW (lb) | |
| | ID | Weapon | Type | SG ^a | | | | | | |
| A1 | Mk55 | Mine | HBX-1 | 8 | // | 2 | 2 | 1290 | 2580 | 5580 |
| | Mk103 | Torpedo WH | H6 | 8 | // | 1 | 4 | 100 | 400 | |
| | Mk107 | Torpedo WH | PBXN-103 | 8 | // | 4 | 4 | 650 | 2600 | |
| | Mk82 | Bomb | Inert | 4 | // | - | 1 | - | - | |
| A2 | Mk82 | Bomb | H6 | 4 | // | 3 | 18 | 192 | 3456 | 7461 |
| | Mk83 | Bomb | H6 | 4 | // | 3 | 9 | 445 | 4005 | |
| | Mk82 | Bomb | Inert | 4 | // | - | 1 | - | - | |
| A3 | Mk82 | Bomb | H6 | 4 | ⊥ | 3 | 18 | 192 | 3456 | 6206 |
| | Mk83 | Bomb | H6 | 4 | ⊥ | 2 | 6 | 445 | 2670 | |
| | M107 | 155mm Projectile | Comp B | 4 | // | 1 | 8 | 10 | 80 | |
| | Mk82 | Bomb | Inert | 4 | ⊥ | - | 1 | - | - | |
| A4 | Mk55 | Mine | HBX-1 | 8 | ⊥ | 4 | 4 | 1290 | 5160 | 8210 |
| | Mk103 | Torpedo WH | H6 | 8 | // | 1 | 4 | 100 | 400 | |
| | Mk107 | Torpedo WH | PBXN-103 | 8 | ⊥ | 4 | 4 | 650 | 2600 | |
| | M107 | 155mm Projectile | Comp B | 4 | // | 1 ^d | 5 | 10 | 50 | |
| | M107 | 155mm Projectile | Instr ^e | 4 | // | 1 ^d | 3 | - | - | |
| | Mk82 | Bomb | Inert | 4 | // | - | 1 | - | - | |

^a High Performance Magazine Storage Group
27,457 lb

Total Acceptor NEW =

^b // = Parallel to nonpropagation wall; ⊥ = Perpendicular to nonpropagation wall

^c Pallets or containers

^d Partially filled pallet

^e US Army WES HDAS accelerometers mounted in each projectile

Table 2. Measured peak pressure at altitude ($z = 5,000$ ft).

| Gauge No. | Location | | | Peak Pressure p_z (psi) |
|-----------|------------------|----------------------|----------------------------------|---------------------------|
| | Azimuth (Degree) | Range from Wall (ft) | Range from Donor c.g. R_z (ft) | |
| F-1 | Front (0°) | 620 | 631.0 | 1.70 |
| F-2 | | 930 | 941.0 | 1.10 |
| F-3 | | 1240 | 1251.0 | 0.74 |
| F-4 | | 1550 | 1561.0 | 0.71 |
| B-1 | Back (180°) | 620 | 661.5 | 1.85 |
| B-2 | | 930 | 971.5 | 1.10 |
| B-3 | | 1240 | 1281.5 | 0.85 |
| B-4 | | 1550 | 1591.5 | 0.60 |
| S-1 | Side (270°) | 620 | 663.5 | 1.75 |
| S-2 | | 930 | 973.5 | 1.00 |
| S-3 | | 1240 | 1283.5 | 0.75 |
| S-4 | | 1550 | 1593.5 | 0.55 |

Table 3. Peak pressures adjusted for sea level.

| Gauge No. | Adjusted Range from Donor c.g. R_o (ft) | Measured Adjusted Peak Pressure, p_o (psi) | Predicted Peak Pressure p_o (psi) |
|-----------|---|--|-------------------------------------|
| F-1 | 593.8 | 2.04 | 3.20 |
| F-2 | 885.5 | 1.32 | 1.82 |
| F-3 | 1177.2 | 0.89 | 1.26 |
| F-4 | 1468.9 | 0.85 | 0.95 |
| B-1 | 622.5 | 2.22 | 2.98 |
| B-2 | 914.2 | 1.32 | 1.74 |
| B-3 | 1205.9 | 1.02 | 1.22 |
| B-4 | 1497.6 | 0.72 | 0.93 |
| S-1 | 624.4 | 2.10 | 2.97 |
| S-2 | 916.1 | 1.20 | 1.74 |
| S-3 | 1207.8 | 0.90 | 1.22 |
| S-4 | 1499.5 | 0.66 | 0.93 |

Table 4. Debris density in front recovery sector.

| Zone No. | Range (ft) | | Number of Debris, N | Area Covered (ft ²) | Debris Density (per 600 ft ²) |
|----------|-------------|-----------|---------------------------|---------------------------------------|---|
| | Near to Far | To Center | | | |
| 1 | 1900-2000 | 1950 | 187 | 34,033 | 3.297 |
| 2 | 1920-2020 | 1970 | 209 | 34,382 | 3.647 |
| 3 | 1940-2040 | 1990 | 198 | 34,732 | 3.421 |
| 4 | 1960-2060 | 2010 | 168 | 35,081 | 2.873 |
| 5 | 1980-2080 | 2030 | 145 | 35,430 | 2.456 |
| 6 | 2000-2100 | 2050 | 135 | 35,779 | 2.264 |
| 7 | 2020-2120 | 2070 | 112 | 36,128 | 1.860 |
| 8 | 2040-2140 | 2090 | 101 | 36,477 | 1.661 |
| 9 | 2060-2160 | 2110 | 102 | 36,826 | 1.662 |
| 10 | 2080-2180 | 2130 | 98 | 37,175 | 1.582 |
| 11 | 2100-2200 | 2150 | 86 | 37,524 | 1.375 |
| 12 | 2120-2220 | 2170 | 81 | 37,873 | 1.283 |
| 13 | 2140-2240 | 2190 | 68 | 38,222 | 1.067 |
| 14 | 2160-2260 | 2210 | 55 | 38,571 | 0.856 |
| 15 | 2180-2280 | 2230 | 44 | 38,920 | 0.678 |
| 16 | 2200-2300 | 2250 | 43 | 39,269 | 0.657 |
| 17 | 2220-2320 | 2270 | 44 | 39,618 | 0.666 |
| 18 | 2240-2340 | 2290 | 44 | 39,968 | 0.661 |
| 19 | 2260-2360 | 2310 | 37 | 40,317 | 0.551 |
| 20 | 2280-2380 | 2330 | 30 | 40,666 | 0.443 |
| 21 | 2300-2400 | 2350 | 27 | 41,015 | 0.395 |
| 22 | 2320-2420 | 2370 | 20 | 41,364 | 0.290 |
| 23 | 2340-2440 | 2390 | 17 | 41,713 | 0.245 |
| 24 | 2360-2460 | 2410 | 17 | 42,062 | 0.243 |
| 25 | 2380-2480 | 2430 | 16 | 42,411 | 0.226 |
| 26 | 2400-2500 | 2450 | 15 | 42,760 | 0.210 |

| Zone No. | Range (ft) | | Number of Debris, N | Area Covered (ft ²) | Debris Density (per 600 ft ²) |
|----------|-------------|-----------|---------------------------|---------------------------------------|---|
| | Near to Far | To Center | | | |
| 27 | 2420-2520 | 2470 | 18 | 43,109 | 0.250 |
| 28 | 2440-2540 | 2490 | 20 | 43,458 | 0.276 |
| 29 | 2460-2560 | 2510 | 18 | 43,807 | 0.247 |
| 30 | 2480-2580 | 2530 | 19 | 44,156 | 0.258 |
| 31 | 2500-2600 | 2550 | 18 | 44,505 | 0.243 |
| 32 | 2520-2620 | 2570 | 12 | 44,854 | 0.161 |
| 33 | 2540-2640 | 2590 | 8 | 45,203 | 0.106 |
| 34 | 2560-2660 | 2610 | 11 | 45,553 | 0.145 |
| 35 | 2580-2680 | 2630 | 11 | 45,902 | 0.144 |
| 36 | 2600-2700 | 2650 | 13 | 46,251 | 0.169 |
| 37 | 2620-2720 | 2670 | 15 | 46,600 | 0.193 |
| 38 | 2640-2740 | 2690 | 13 | 46,949 | 0.166 |
| 39 | 2660-2760 | 2710 | 7 | 47,298 | 0.089 |
| 40 | 2680-2780 | 2730 | 8 | 47,647 | 0.101 |
| 41 | 2700-2800 | 2750 | 6 | 47,996 | 0.075 |
| 42 | 2720-2820 | 2770 | 4 | 48,345 | 0.050 |
| 43 | 2740-2840 | 2790 | 5 | 48,694 | 0.062 |
| 44 | 2760-2860 | 2810 | 7 | 49,043 | 0.086 |
| 45 | 2780-2880 | 2830 | 5 | 49,392 | 0.061 |
| 46 | 2800-2900 | 2850 | 5 | 49,741 | 0.060 |
| 47 | 2820-2920 | 2870 | 9 | 50,090 | 0.108 |
| 48 | 2840-2940 | 2890 | 9 | 50,439 | 0.107 |
| 49 | 2860-2960 | 2910 | 8 | 50,789 | 0.095 |
| 50 | 2880-2980 | 2930 | 8 | 51,138 | 0.094 |

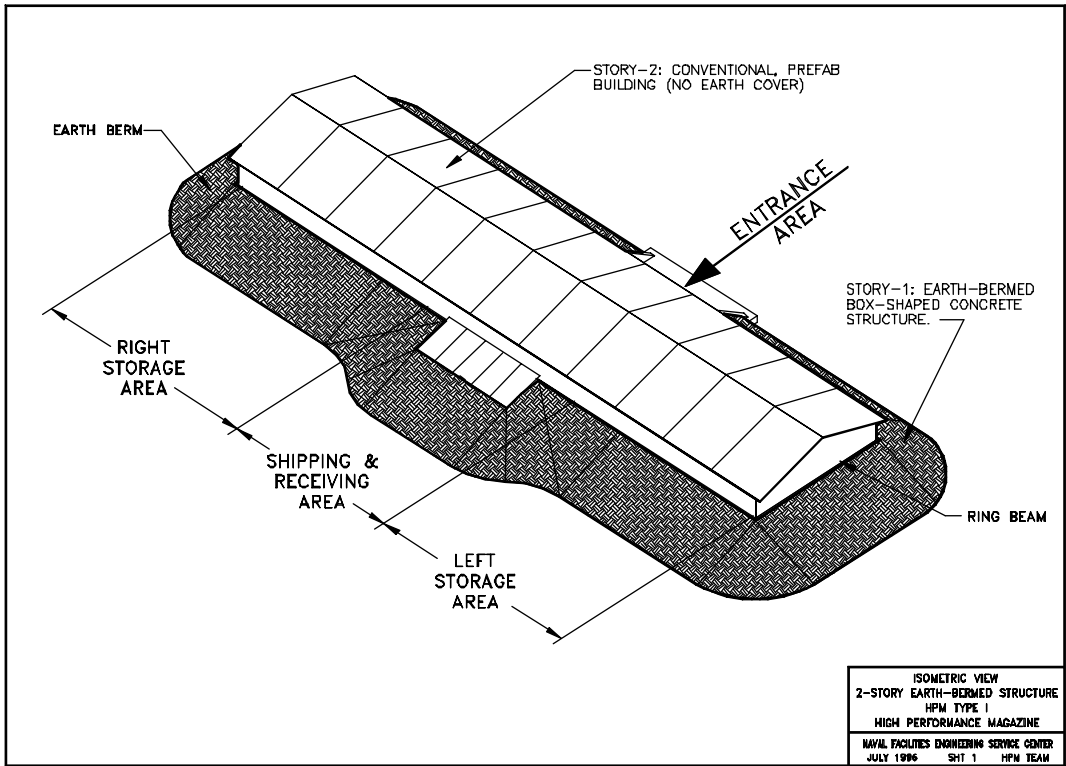

Figure 1. HP Magazine: Isometric view.

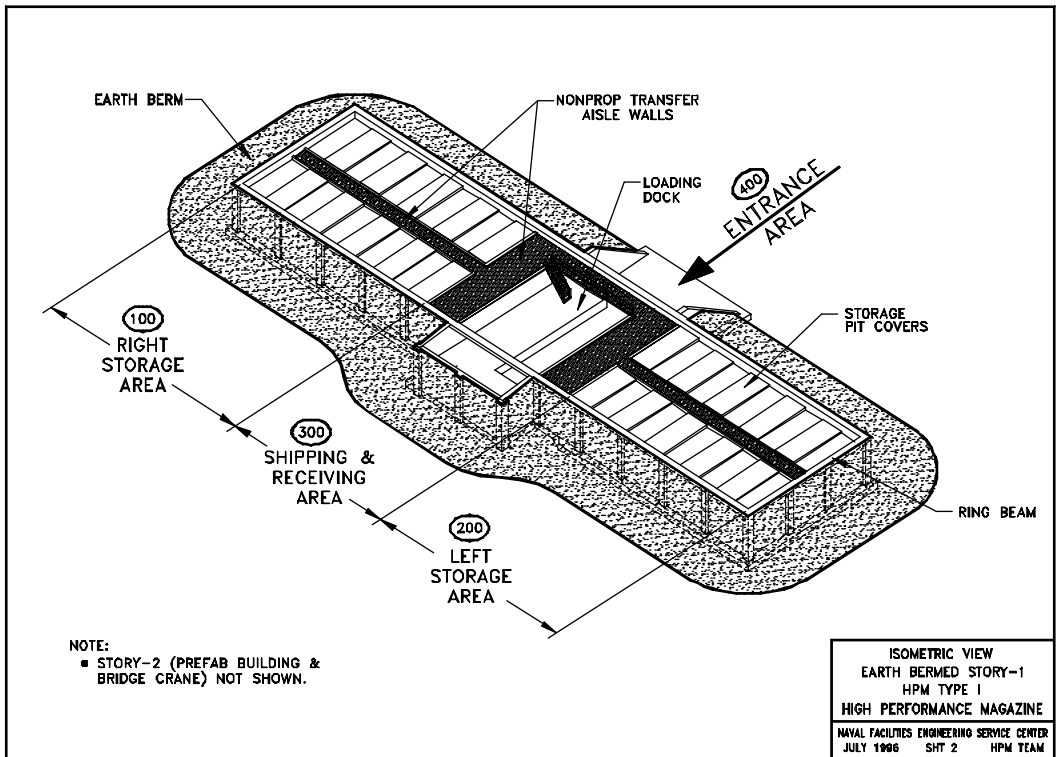

Figure 2. HP Magazine: Story-1.

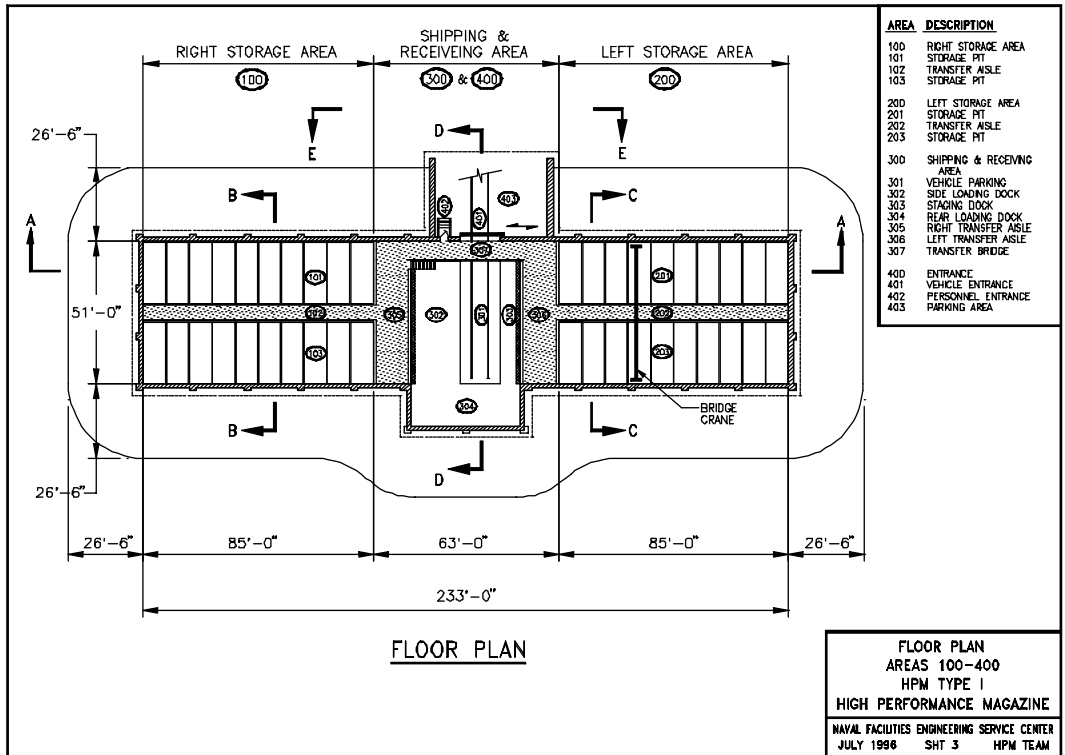

Figure 3. HP Magazine: Floor plan.

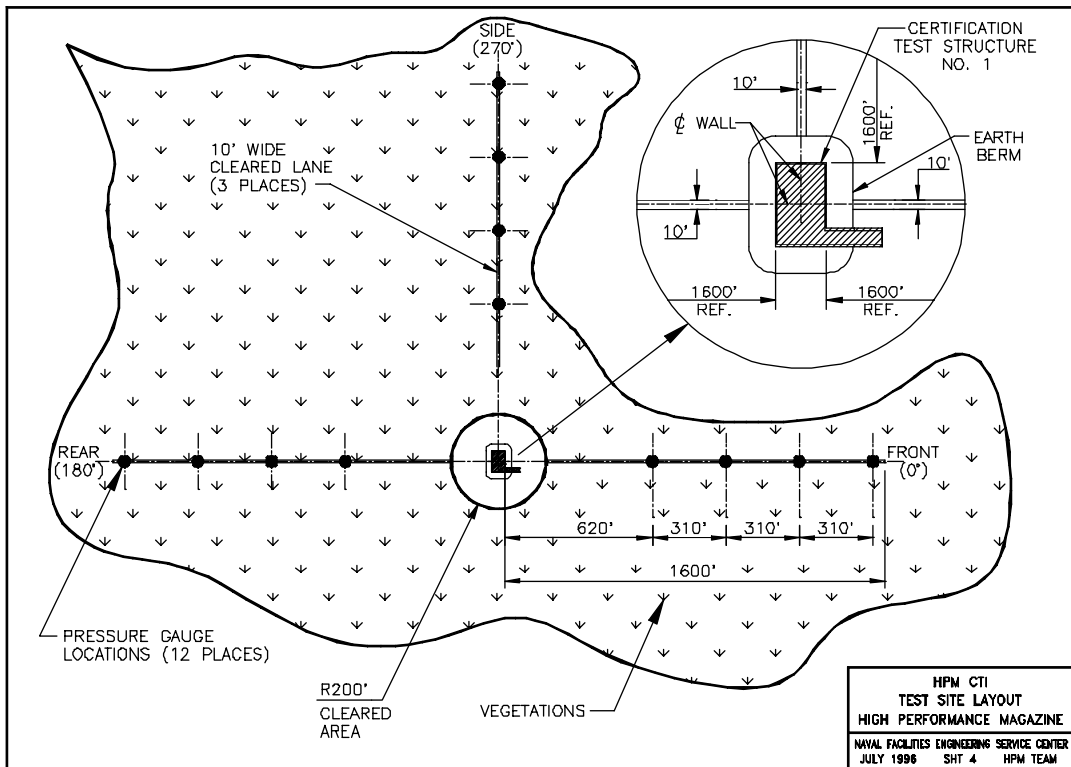

Figure 4. Test site layout.

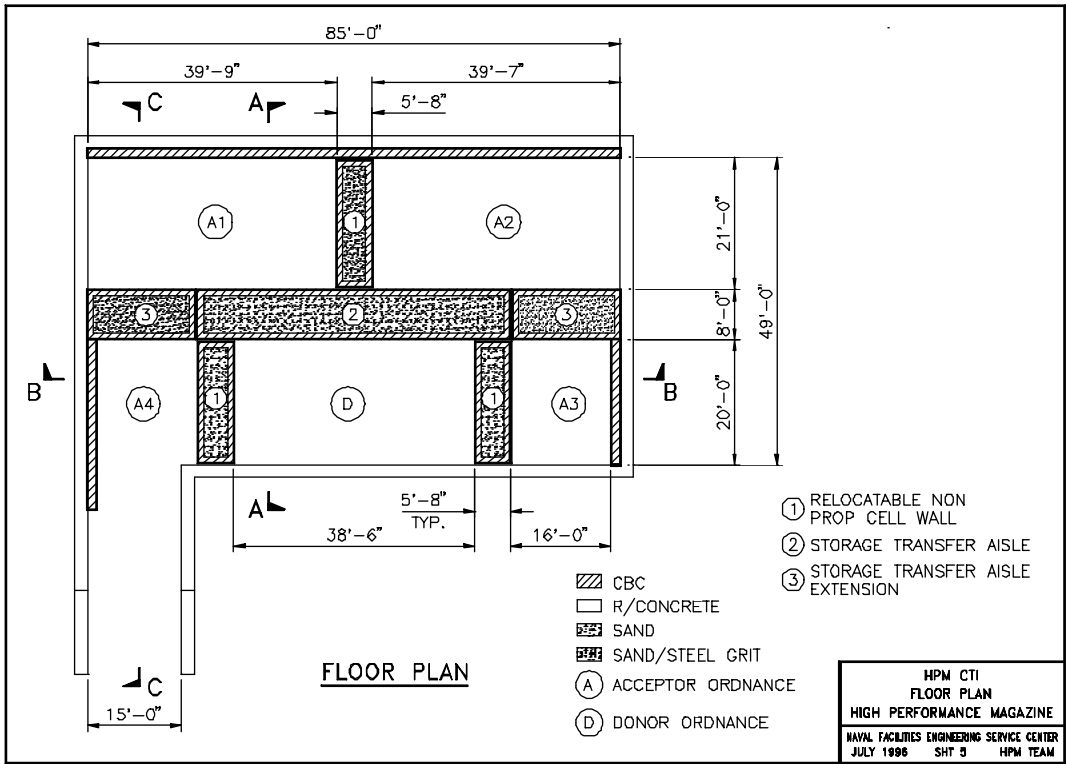

Figure 5. CT1 Structure: Floor plan.

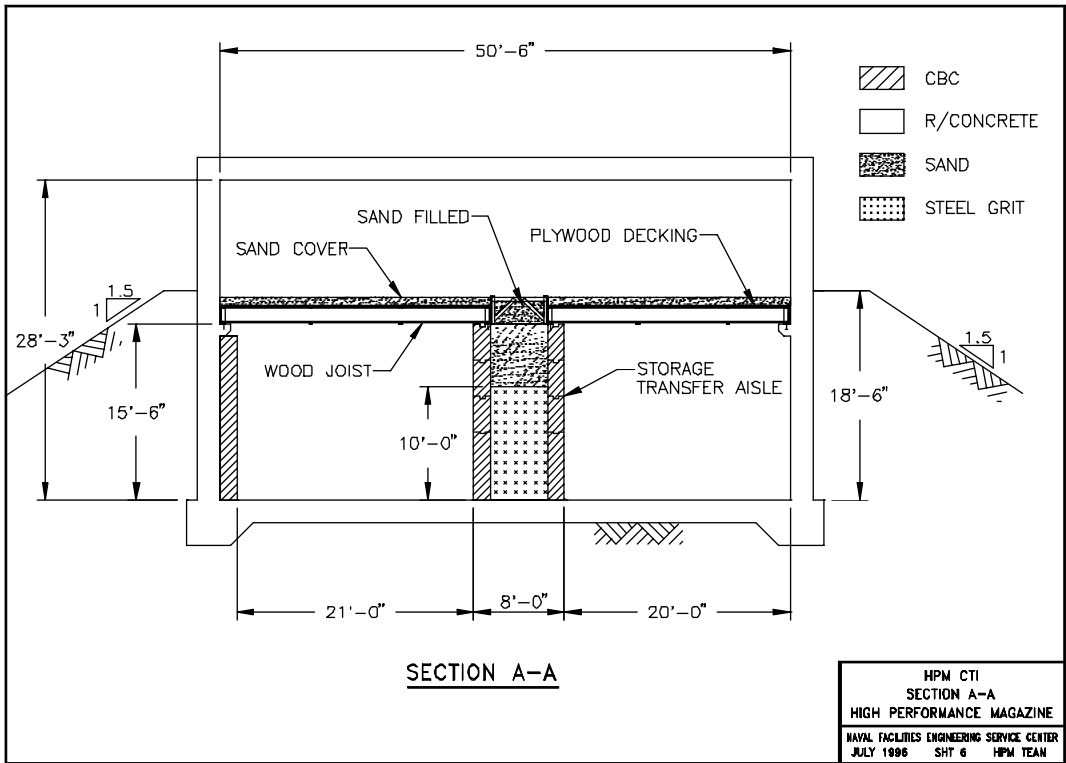

Figure 6. CT1 Structure: Section A-A.

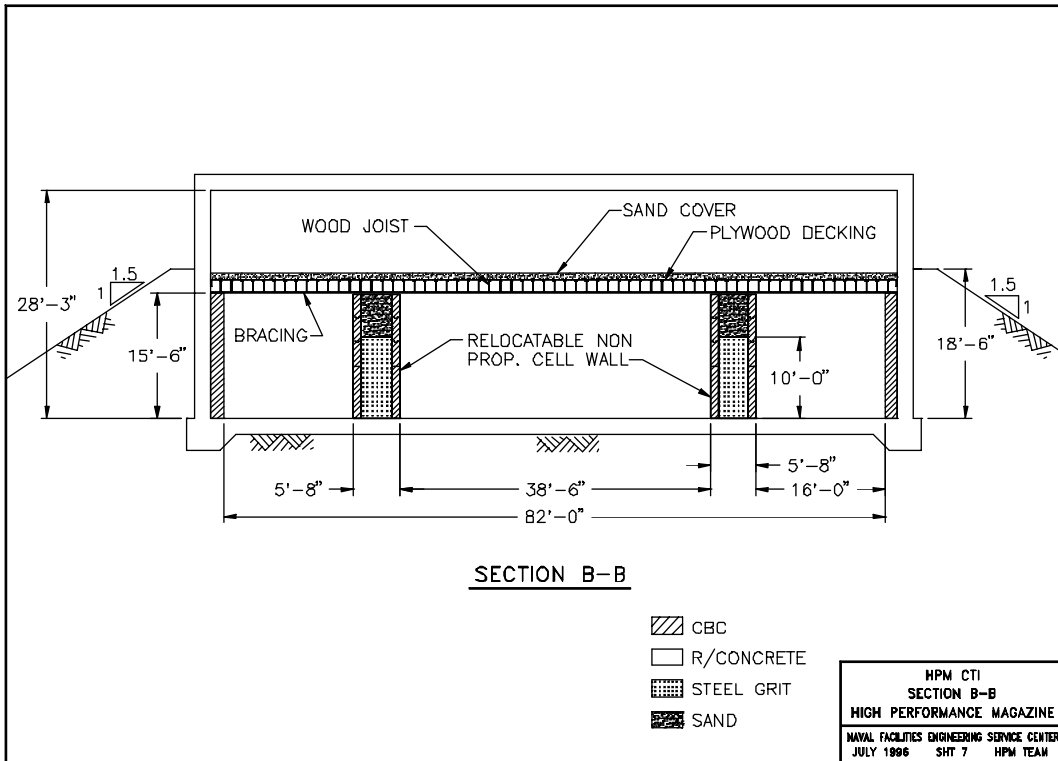

Figure 7. CT1 Structure: Section B-B.

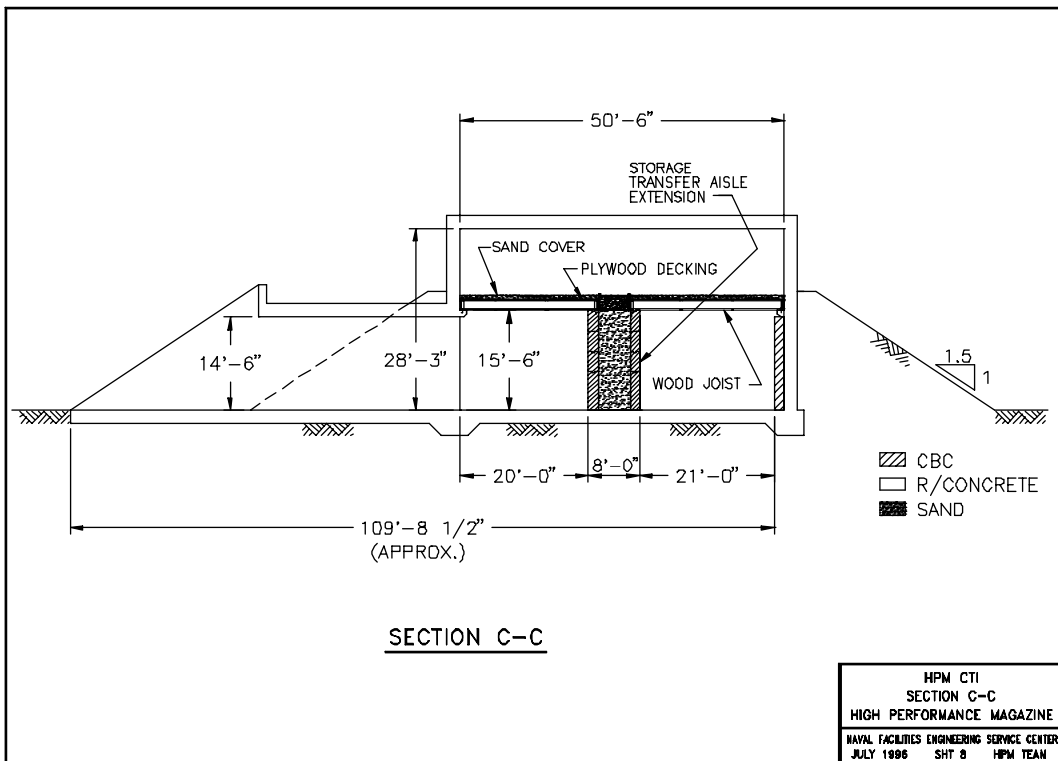

Figure 8. CT1 Structure: Section C-C.

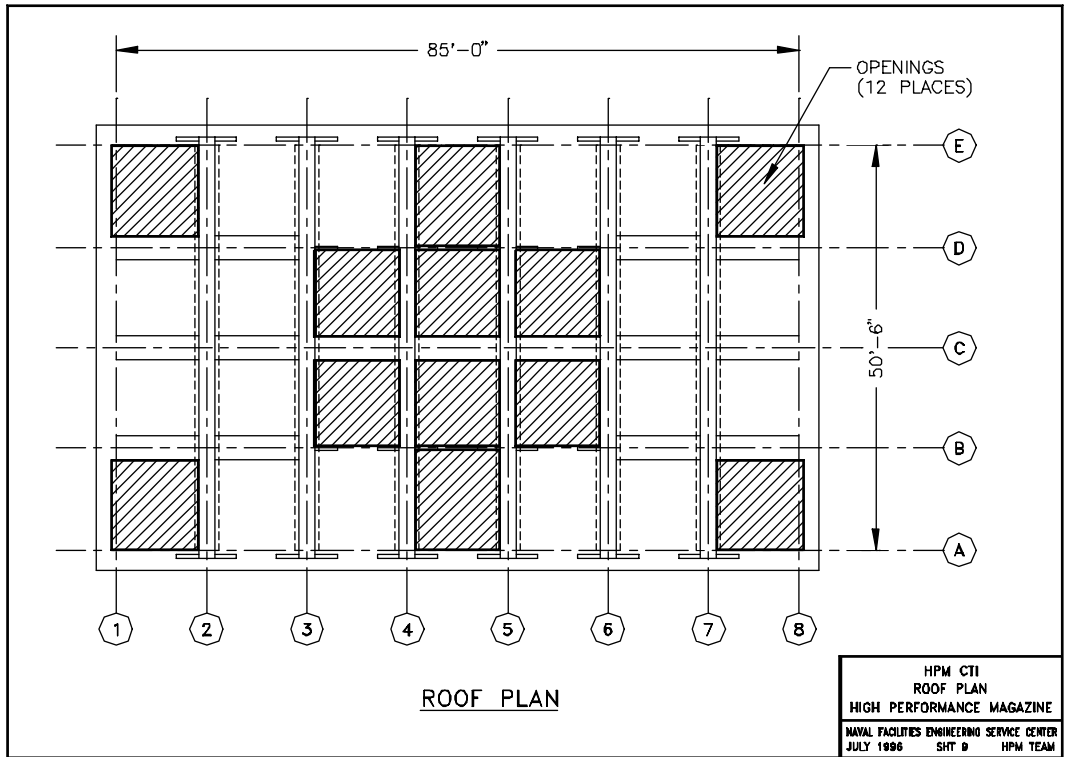

Figure 9. CT1 Structure: Roof plan.



Figure 10. Exterior view of CT1 structure.



Figure 11. Interior view of CT1 structure.



Figure 12. Portion of aisle wall.

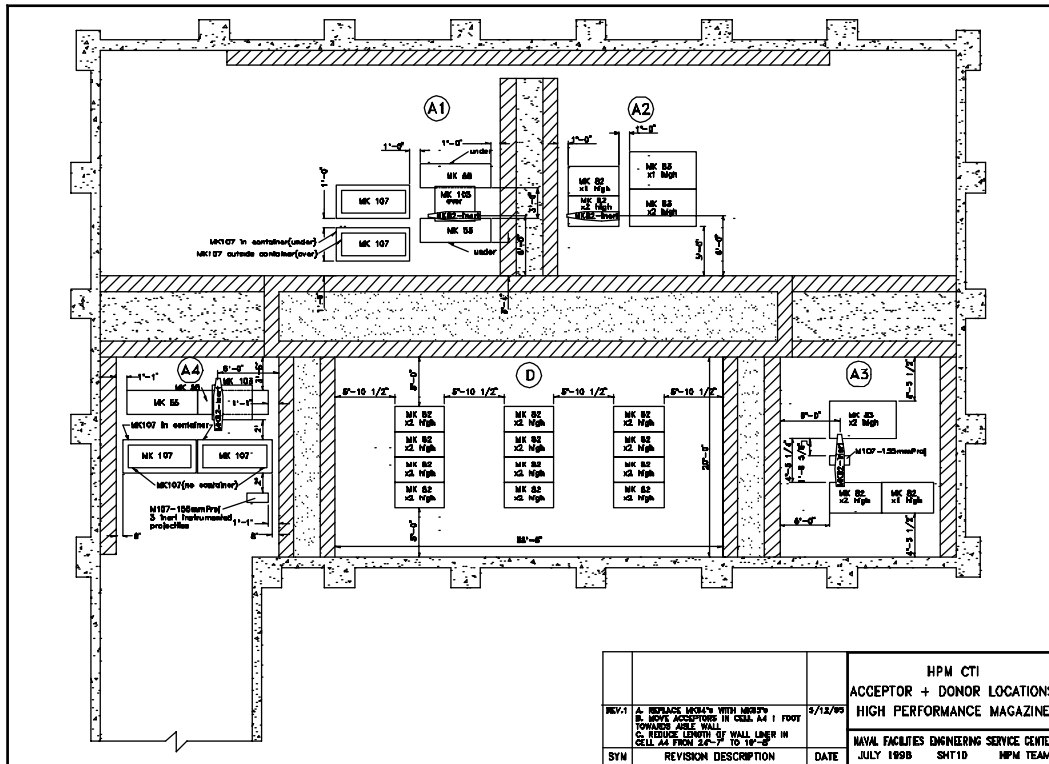

Figure 13. Acceptor and donor locations.



Figure 14. Mk82 donor ordnance.



Figure 15. Acceptor ordnance inside Cell A1.



Figure 16. Acceptor ordnance inside Cell A2.



Figure 17. Acceptor ordnance inside Cell A3.



Figure 18. Acceptor ordnance inside Cell A4.



Figure 19. CT1 site: Pre-detonation.



Figure 20. CT1 site: Fireball.



Figure 21. CT1 site: Burning ordnance.



Figure 22. View of CT1 structure taken from 90° azimuth.



Figure 23. View of CT1 structure taken from 270° azimuth.

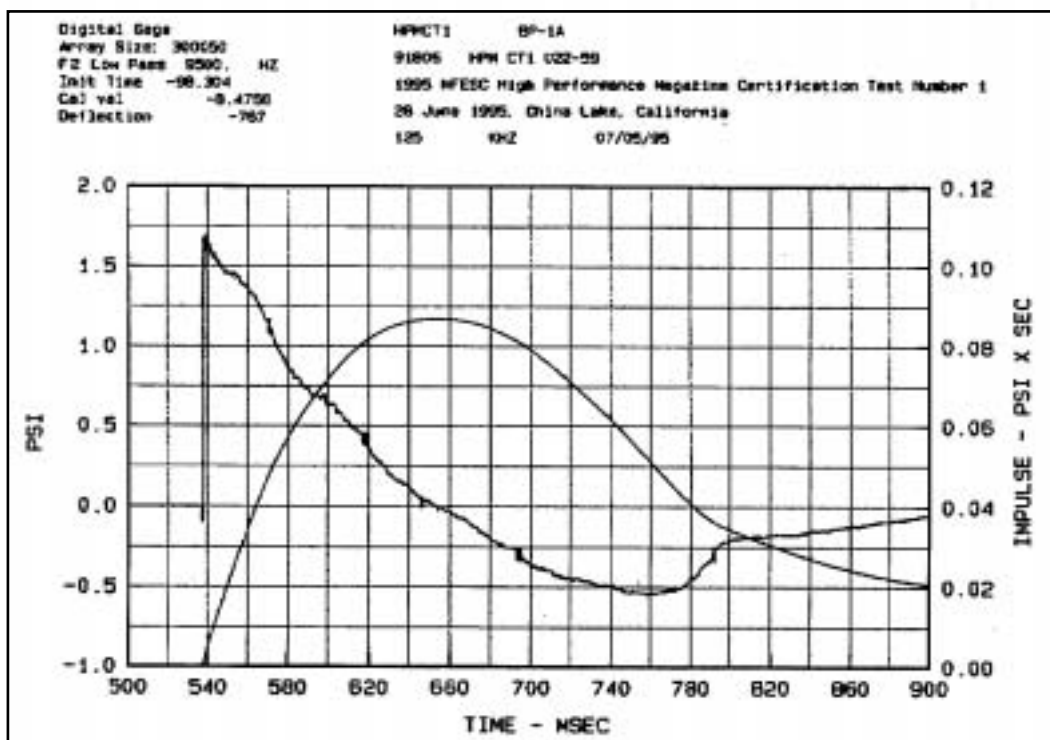

Figure 24. External airblast pressure measurement F-1.

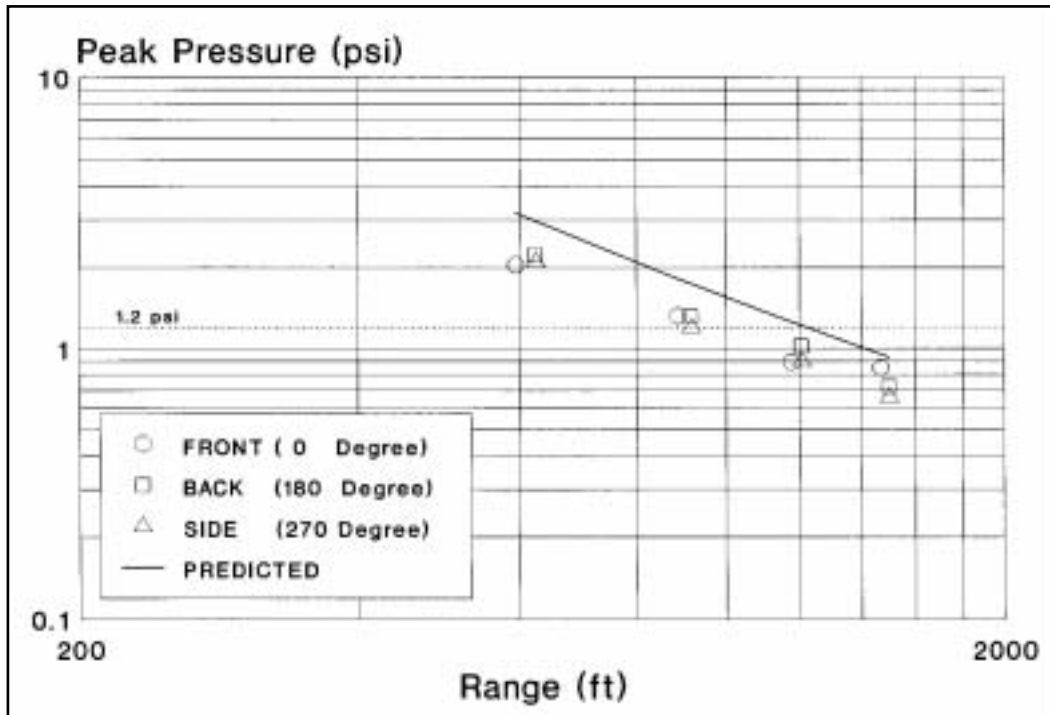

Figure 25. Measured versus predicted peak external pressures.

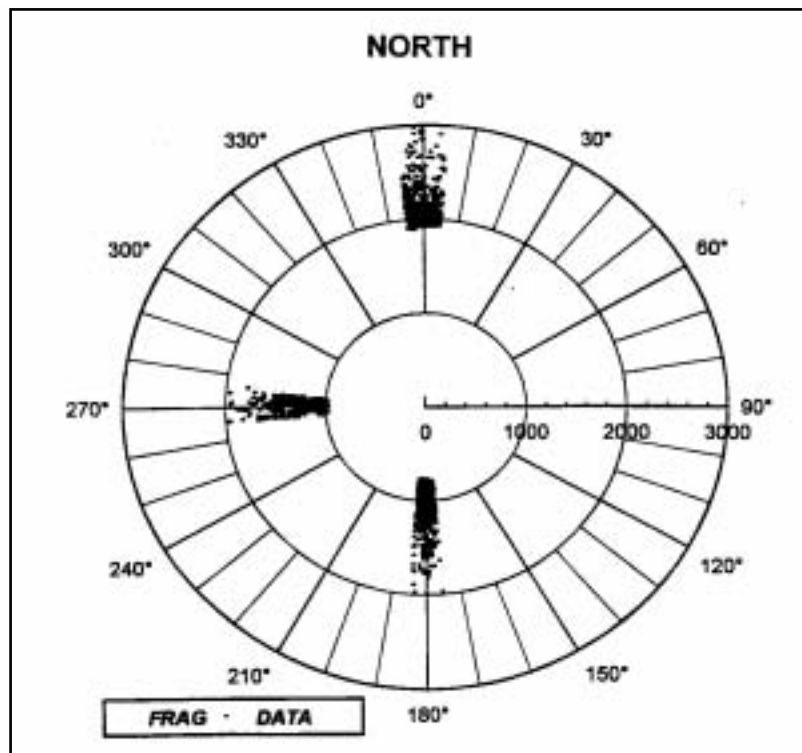

Figure 26. Polar plot of hazardous debris locations.

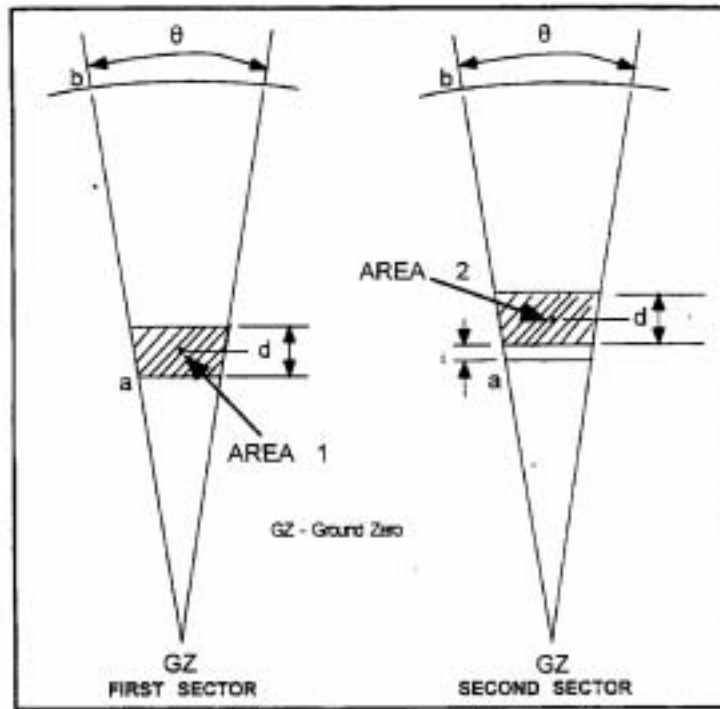

Figure 27. Schematic representation of the Jacob's Method.

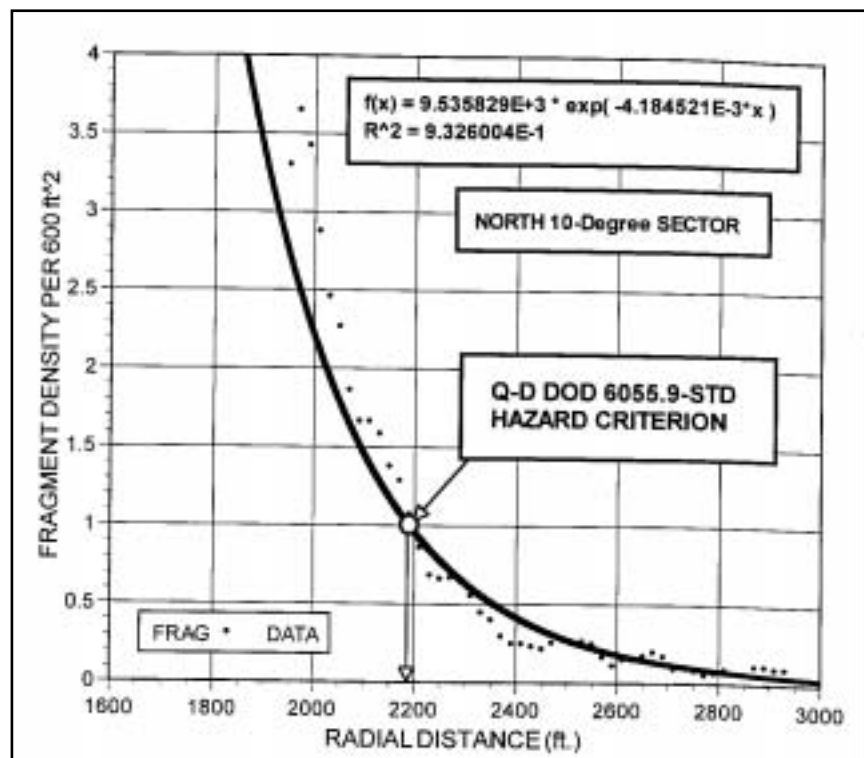

Figure 28. Debris areal number density distribution: Front sector.

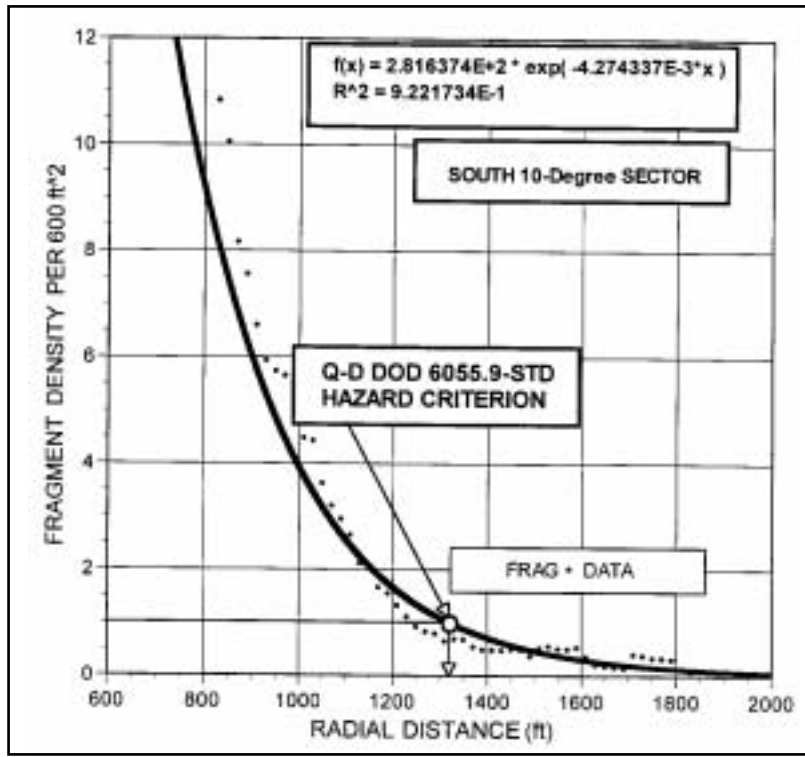

Figure 29. Debris areal number density distribution: Back sector.

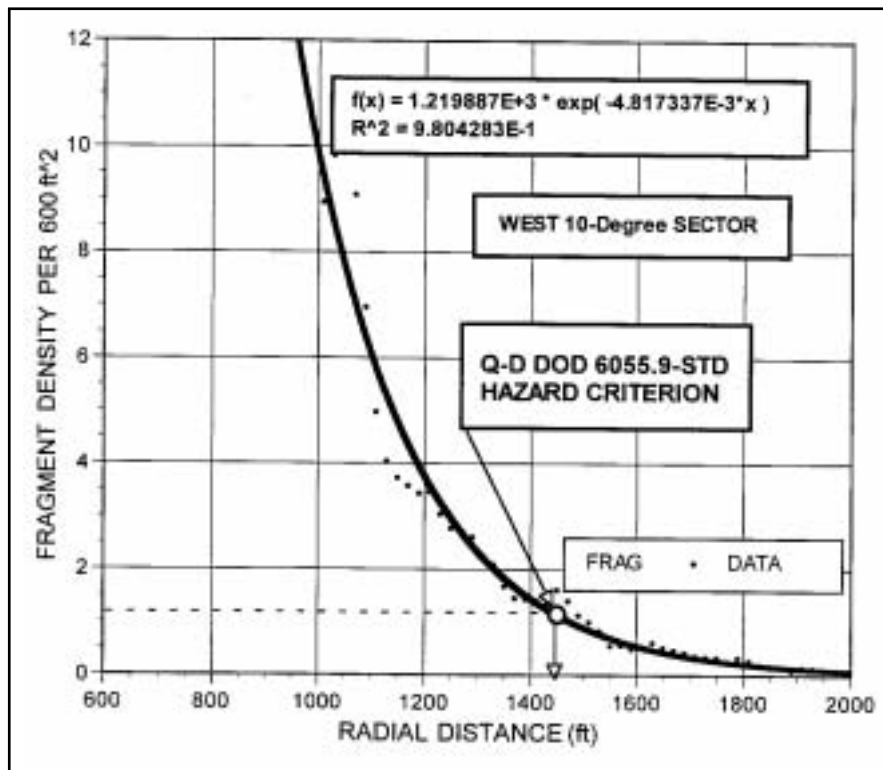

Figure 30. Debris areal number density distribution: Side sector.



Figure 31. Mk82 and Mk83 bombs from Cell A3.



Figure 32. Mk103 torpedo warhead from Cell A4.



Figure 33. Mk103 torpedo warhead from Cell A1.



Figure 34. Two Mk55 mines from Cell A4.



Figure 35. First Mk55 mine from Cell A1.



Figure 36. Second Mk55 mine from Cell A1.



Figure 37. Mk107 torpedo warhead from Cell A1.