

GPS-BASED NETWORK SYNTONIZATION VIA
NONMAGNETIC CONTROL OF CESIUM STANDARDS

by

E.A. Rodrigo and J. Howell

Research and Development, Austin Group
Austron, Inc., P.O. Box 14766, Austin, Texas 78761

and

J. Barnes and J. D. Echols

Research and Development, Boulder Group
Austron, Inc., 3300 Mitchell Lane Ste. 370, Boulder, Colorado 80301

ABSTRACT

Cesium-based atomic standards are typically accurate to about seven parts in ten to the twelfth. However, certain applications require better agreement among standards. One example is that of a communications network. Network-wide syntonization requires each standard in the network to be adjusted to agree with a master external reference. This is normally accomplished by adjusting the "C" field of each atomic standard. However, causing precise output frequency changes in this way is notoriously difficult. It also reduces frequency stability until the standard eventually settles into a new free-running frequency.

There are two ways in which the output of a cesium standard can be adjusted without changing its "C" field. The internal synthesizer of the standard can be adjusted, or a phase microstepper can be used on its output. The former technique shifts the output frequency in small, discrete steps, while the latter inserts small, discrete phase shifts into the output signal. Using common-view Global Positioning System (GPS) as a master reference, this investigation tests both techniques and determines the degree of syntonization and synchronization possible with each.

Report Documentation Page

Form Approved
OMB No. 0704-0188

Public reporting burden for the collection of information is estimated to average 1 hour per response, including the time for reviewing instructions, searching existing data sources, gathering and maintaining the data needed, and completing and reviewing the collection of information. Send comments regarding this burden estimate or any other aspect of this collection of information, including suggestions for reducing this burden, to Washington Headquarters Services, Directorate for Information Operations and Reports, 1215 Jefferson Davis Highway, Suite 1204, Arlington VA 22202-4302. Respondents should be aware that notwithstanding any other provision of law, no person shall be subject to a penalty for failing to comply with a collection of information if it does not display a currently valid OMB control number.

1. REPORT DATE DEC 1986	2. REPORT TYPE	3. DATES COVERED 00-00-1986 to 00-00-1986			
4. TITLE AND SUBTITLE GPS-Based Network Syntonization via Nonmagnetic Control of Cesium Standards		5a. CONTRACT NUMBER			
		5b. GRANT NUMBER			
		5c. PROGRAM ELEMENT NUMBER			
6. AUTHOR(S)		5d. PROJECT NUMBER			
		5e. TASK NUMBER			
		5f. WORK UNIT NUMBER			
7. PERFORMING ORGANIZATION NAME(S) AND ADDRESS(ES) Austron Inc, Research and Development, Austin Group, PO Box 14766, Austin, TX, 78761		8. PERFORMING ORGANIZATION REPORT NUMBER			
9. SPONSORING/MONITORING AGENCY NAME(S) AND ADDRESS(ES)		10. SPONSOR/MONITOR'S ACRONYM(S)			
		11. SPONSOR/MONITOR'S REPORT NUMBER(S)			
12. DISTRIBUTION/AVAILABILITY STATEMENT Approved for public release; distribution unlimited					
13. SUPPLEMENTARY NOTES Proceedings of the Eighteenth Annual Precise Time and Time Interval (PTTI) Applications and Planning Meeting, Washington, DC, 2-4 Dec 1986					
14. ABSTRACT see report					
15. SUBJECT TERMS					
16. SECURITY CLASSIFICATION OF:			17. LIMITATION OF ABSTRACT	18. NUMBER OF PAGES	19a. NAME OF RESPONSIBLE PERSON
a. REPORT unclassified	b. ABSTRACT unclassified	c. THIS PAGE unclassified	Same as Report (SAR)	13	

INTRODUCTION

An important ancillary usage of the Global Positioning System (GPS) is that in which it serves to distribute time and frequency to remote clocks and frequency standards. In the case in which two ground-based clocks view the same GPS satellite, the theoretical limit on synchronization is about 10 ns [1]. GPS receivers typically provide synchronization to GPS time better than 50 ns, which means that a common-view GPS should allow synchronization of remote receivers to within about 100 ns of each other [1,2].

However, using the common-view approach to GPS to syntonize remote frequency standards (i.e., to cause their frequencies to agree) proves to be a more challenging problem. The crux of the difficulty lies in the relatively high effective frequency instability of the corrected time transmitted by the satellite. Figure 1 shows that although the long-term (50 days) frequency stability a GPS satellite is about a part in 10^{14} , the stability over one day approaches a part in 10^{12} . Suppose that we intend to syntonize two remote frequency standards by measuring their difference to GPS, then adjusting their frequencies to reduce this difference, then repeating the process. If the standards are to be syntonized to within a part in 10^{13} , then each iteration of the control loop would require several days. It would take that long to measure the difference between the frequency standard and GPS to the required accuracy.

The purpose of this note is to determine whether there exists a syntonization method using the common-view GPS approach that gives good results over the short-term (less than 1 day). The idea is to slave two frequency standards to the same satellite, then see how well the standards continue to agree after the satellite is no longer in view. If identical control algorithms are used to control identical frequency standards, using information provided by identical GPS receivers viewing the same satellite, it seems reasonable to expect good agreement between the frequency standards.

EXPERIMENTAL APPARATUS

The experiment was performed in two phases. The experimental setup for Phase 1 is shown in Figure 2. In Phase 1 an Austron Model 2101 GPS Receiver measures the phase difference between the 1-pulse-per-second (1 PPS) signal from the GPS satellite and that produced by an Austron Model 2310 Disciplined Cesium Standard. This difference is read over the IEEE-488 bus by a Hewlett Packard HP-85 computer. A Kalman filter algorithm running on the HP-85 decides the degree to which the disciplined cesium standard's frequency should be shifted in order to minimize the phase difference. The Kalman filter also strives to syntonize the frequency standard to the effective 5 MHz frequency corresponding to the satellite's 1 PPS signal. After the Kalman filter calculates the appropriate frequency shift, the HP-85 commands (via the bus) the disciplined cesium standard to shift its output frequency by this amount. The disciplined cesium standard is a new device whose frequency can be shifted essentially instantaneously without adjusting the "C" magnetic field in its beam tube.

This setup was duplicated elsewhere in the laboratory. A time interval counter measured the phase difference between the 1 PPS output of cesium standard in the first setup and that of the cesium standard in the second. A chart recorder recorded this difference.

The setups, which shall henceforth be referred to as Side A and Side B, shared the same antenna.

Figure 3 shows the experimental setup for Phase 2. The difference between this setup and that of Phase 1 is that the frequency-shifting ability of the disciplined cesium standard is not used. Instead, an Austron Model 2055 Phase Microstepper is used to create a signal whose frequency is shifted from that of the input signal from the cesium standard. The phase microstepper is a device that shifts the frequency of an input signal by inserting or removing phase steps at a rate specified by the user. The phase microstepper does not provide a 1 PPS output. Hence the phase microstepper's frequency output was used to drive a precision 1 PPS synthesizer. As in Phase 1 the GPS receiver informs the HP-85 computer of the phase difference between the output of 1 PPS synthesizer and the satellite. The Kalman filter calculates an amount by which the frequency of the phase microstepper should shift the frequency of the cesium standard. The

HP-85 then commands the phase microstepper to produce this frequency shift. Because the phase microstepper requires BCD rather than IEEE-488 remote input, an IBM PC with an IEEE-488 card was used to translate HP-85 IEEE-488 bus commands to BCD.

The Phase 2 setup was duplicated elsewhere in the laboratory. As in Phase 1, the difference between the 1 PPS from the two setups (Side A and Side B) was monitored on a time interval counter and recorded on a chart recorder.

The GPS receivers of Side A and Side B shared the same antenna.

In both phases the duplication of the HP-85 system controller was simulated. That is, Side A and Side B were controlled by the same computer that simultaneously ran independent programs to control each side. In Phase 2 the duplication of the IBM PC was simulated. Side A and Side B shared the same computer to translate IEEE-488 bus commands to BCD instructions for their phase microsteppers.

In both experimental phases, the receivers tracked satellite vehicle 13 for four hours, then stopped tracking. Tracking resumed one hour later. The phase accumulated between Side A and Side B was recorded. Tracking continued for thirty minutes, then ceased. Tracking resumed sixteen hours later. The accumulation of phase between Side A and Side B that occurred during this sixteen-hour period was also recorded. The frequency offsets corresponding to the phase accumulation that occurred during the times that the satellite was not being tracked (i.e., during the "coast" periods) were calculated and are listed in Tables 2 and 4.

RESULTS

PHASE 1

Table 1 shows the results of ten consecutive trackings of satellite 13. While the satellites were being tracked by the receivers, the average of the difference between the Side A and GPS is 9 ns with a standard deviation of 14 ns.

Table 2 shows that Side A and Side B agreed with each other about two times more closely than Side B agreed with GPS (the ratio of the standard deviations was 1.9). Although the difference between Side A and GPS was not monitored as closely as the difference between Side B and GPS (i.e., readings were not confirmed with a chart recorder), it appeared that the difference between Side A and GPS was comparable in magnitude to the B-GPS measurements listed in Table 2. In other words, Side A and Side B agreed with each other more closely than either agreed with GPS.

Table 1
Phase 1 Tracking Data

MJD	MESSAGE AGE hr	<A-GPS> ns	RMS ns
46761	6	3.6	5
46761	5	25.8	8
46760	6	2.9	5
46760	6	39.5	7
46759	2	3.2	7
46759	6	-2.3	4
46759	3	12.2	8
46758	2	10.7	62
46758	7	3.2	5
46758	5	-10.6	11

Average = 8.8 ns
Standard Dev. = 13.7 ns

Table 2

Phase 1 Coast Data

A-B (frequency offset)	B-GPS (frequency offset)
5.1 x 10 ⁻¹³	2.0 x 10 ⁻¹²
6.6 x 10 ⁻¹³	-2.9 x 10 ⁻¹²
-4.1 x 10 ⁻¹³	3.2 x 10 ⁻¹²
5.7 x 10 ⁻¹³	-3.9 x 10 ⁻¹²
-9.6 x 10 ⁻¹³	-8.1 x 10 ⁻¹²
9.1 x 10 ⁻¹²	7.4 x 10 ⁻¹²
6.7 x 10 ⁻¹³	1.1 x 10 ⁻¹¹
7.8 x 10 ⁻¹²	-3.7 x 10 ⁻¹²
7.2 x 10 ⁻¹³	3.4 x 10 ⁻¹²
-9.1 x 10 ⁻¹³	1.2 x 10 ⁻¹¹
Avg. = 1.8 x 10 ⁻¹²	Avg. = 2.0 x 10 ⁻¹²
Standard Dev. = 3.4 x 10 ⁻¹²	Standard Dev. = 6.4 x 10 ⁻¹²

PHASE 2

Table 3 shows that the phase microstepper was able to track the GPS an order of magnitude more closely than the disciplined cesium standard used in Phase 1. The average phase difference was 0.8 ns with a standard deviation of 1.5 ns, although the sample size is small. This improved synchronization may be due to microstepper's ability to cause frequency shifts ten times larger than the maximum frequency shifts that can be produced by the disciplined cesium standard.

At first glance of Table 4 it appears as though syntonization in Phase 2 was also superior by an order of magnitude: -2.3×10^{-13} instead of 1.8×10^{-12} . However, the standard deviation of 2×10^{-12} is much larger than the sample mean 2.3×10^{-13} . Thus the relevant

Table 3

Phase 2 Tracking Data

MJD	MESSAGE AGE hr	<A-GPS> ns	RMS ns
46764	6	0.8	5
46764	4	2.7	57
46763	6	-0.1	5
46763	6	-0.6	4
46763	3	3.5	58
46762	6	-0.8	4
46762	6	.3	7

Average = 0.8 ns
Standard Dev. = 1.5 ns

Table 4

Phase 2 Coast Rate

A-B (frequency offset)	B-GPS (frequency offset)
4.2×10^{-13}	-1.0×10^{-12}
-7.3×10^{-13}	-2.9×10^{-12}
-4.6×10^{-12}	1.2×10^{-11}
8.0×10^{-13}	-3.9×10^{-12}
7.2×10^{-13}	-6.2×10^{-12}
-6.1×10^{-13}	9.4×10^{-12}
2.4×10^{-12}	1.2×10^{-11}
Avg. = -2.3×10^{-13}	Avg. = 2.8×10^{-12}
Standard Dev. = 2.0×10^{-12}	Standard Dev. = 7.4×10^{-12}

measure of syntonization in this case is the standard deviation, not the average offset. Hence, the syntonization achieved in Phase 2 (2.0×10^{-12}) is comparable to that achieved in Phase 1 (3.4×10^{-12}).

As in Phase 1, Side A and Side B were syntonized to each other (standard deviation of 2.0×10^{-12}) better than they were syntonized to GPS (standard deviation of 7.4×10^{-12}).

CONCLUSIONS

While a satellite is in common view, it is possible to use a Kalman filter to synchronize disciplined cesium standards to each other to better than 15 ns. When the frequency shifting is performed by phase microsteppers instead of by the disciplined cesium standards, syntonization was about an order of magnitude closer. This may be due to the microstepper's ability to remove large phase differences (which were usually observed at the end of the interval during which the satellite was not being tracked) at a rate ten times faster than the disciplined cesium standards.

The syntonizations achieved between disciplined cesium standards was about 4×10^{-12} . However, the syntonization between the cesium standards was twice as close when the frequency shifting was performed by phase microsteppers. Again this may be due to the microstepper's ability to move more rapidly than the disciplined cesium standard. In both cases, when the satellite was not in view, the syntonization between the independent frequency standards to each other was better (by a factor of 2 to 4) than the syntonization of the standards to GPS. This is probably due to the relatively poor short-term stability of GPS caused by upload transmissions.

Although in the current GPS environment the phase microstepper performs somewhat better than the disciplined cesium standard in achieving short-term syntonizations and synchronizations, it seems likely that the disciplined cesium standard is better suited to the long term. This is because the disciplined cesium standard has a theoretical frequency-shift resolution 70 percent better than that of the phase microstepper. As GPS is improved and its effective frequency instability is reduced, sole advantage of the phase microstepper approach (faster slew rate) will be outweighed by its disadvantages — the need for additional hardware and the reduction of spectral purity.

In summary, the disciplined cesium standard provides an alternative means of syntonizing to a master reference (such as GPS). Its effectiveness relative to the phase microstepper approach is limited only by its slower slew rate. This makes it well suited for long-term applications involving extremely stable master references.

REFERENCES

1. D.W. Allan and M.A. Weiss, "Time and Frequency Transfer During Common-View of a GPS Satellite", Proc. 34th Ann. Frequency Control Symposium, 334 (1980)
2. K. Putkovich, "Initial Test Results of USNO GPS Time Transfer Unit", Proc. 34th Frequency Control Symposium, 326 (1980)

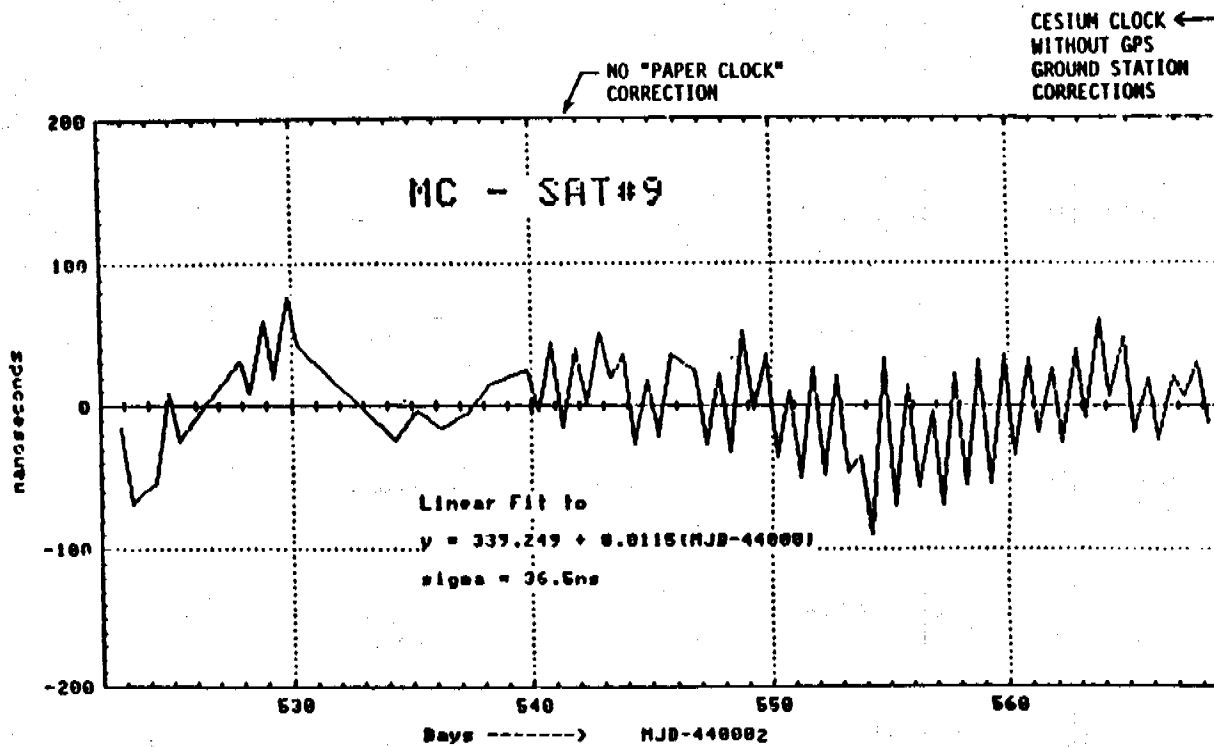

$$\frac{\sqrt{2\Delta T}}{T} = \frac{\sqrt{2 \times 36.5n \text{ SEC}}}{50 \times 80,000 \text{ SEC}} \approx \frac{\sqrt{2 \times 40 \times 10^{-9}}}{4 \times 10^6} = \sqrt{2 \times 10^{-14}}$$

USNO data reprinted from Advanced GPS Receiver Design by
 Navigation Technology Seminars, Inc., Falls Church 1984

Figure 1.

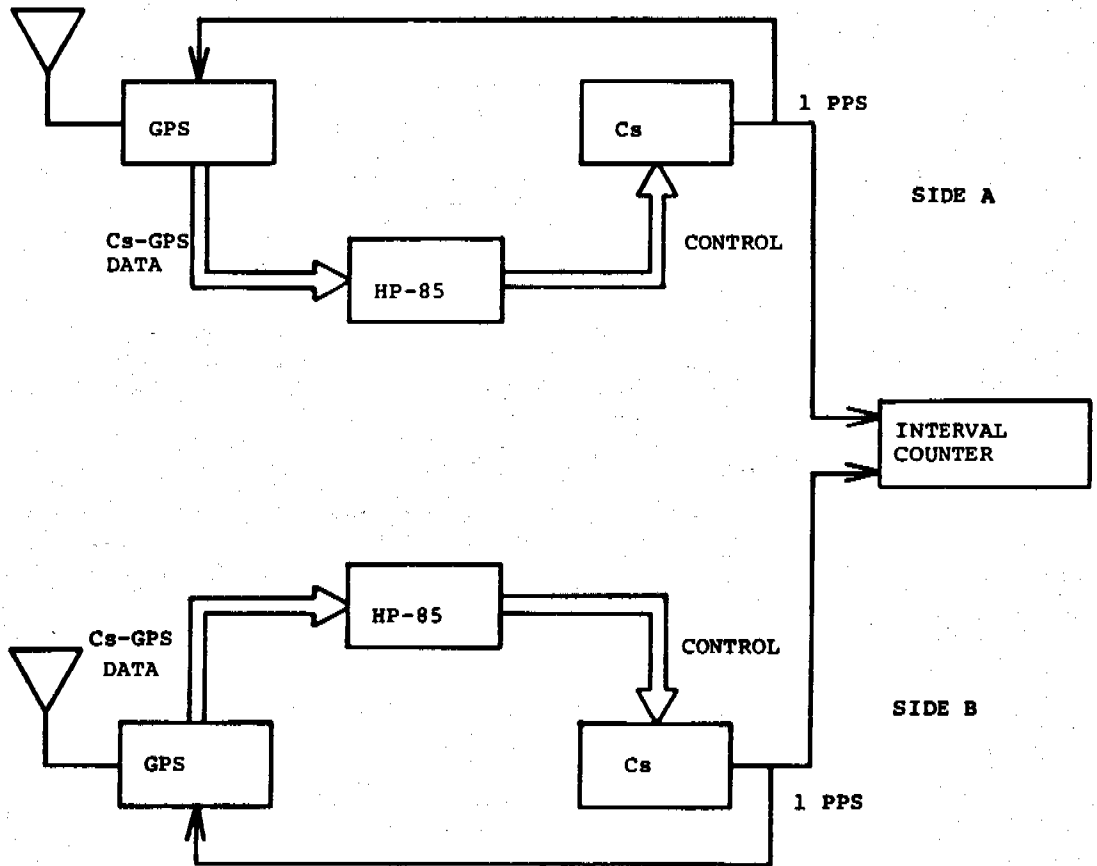

In actual setup Side A and Side B shared HP-85 and GPS antenna.

Figure 2.

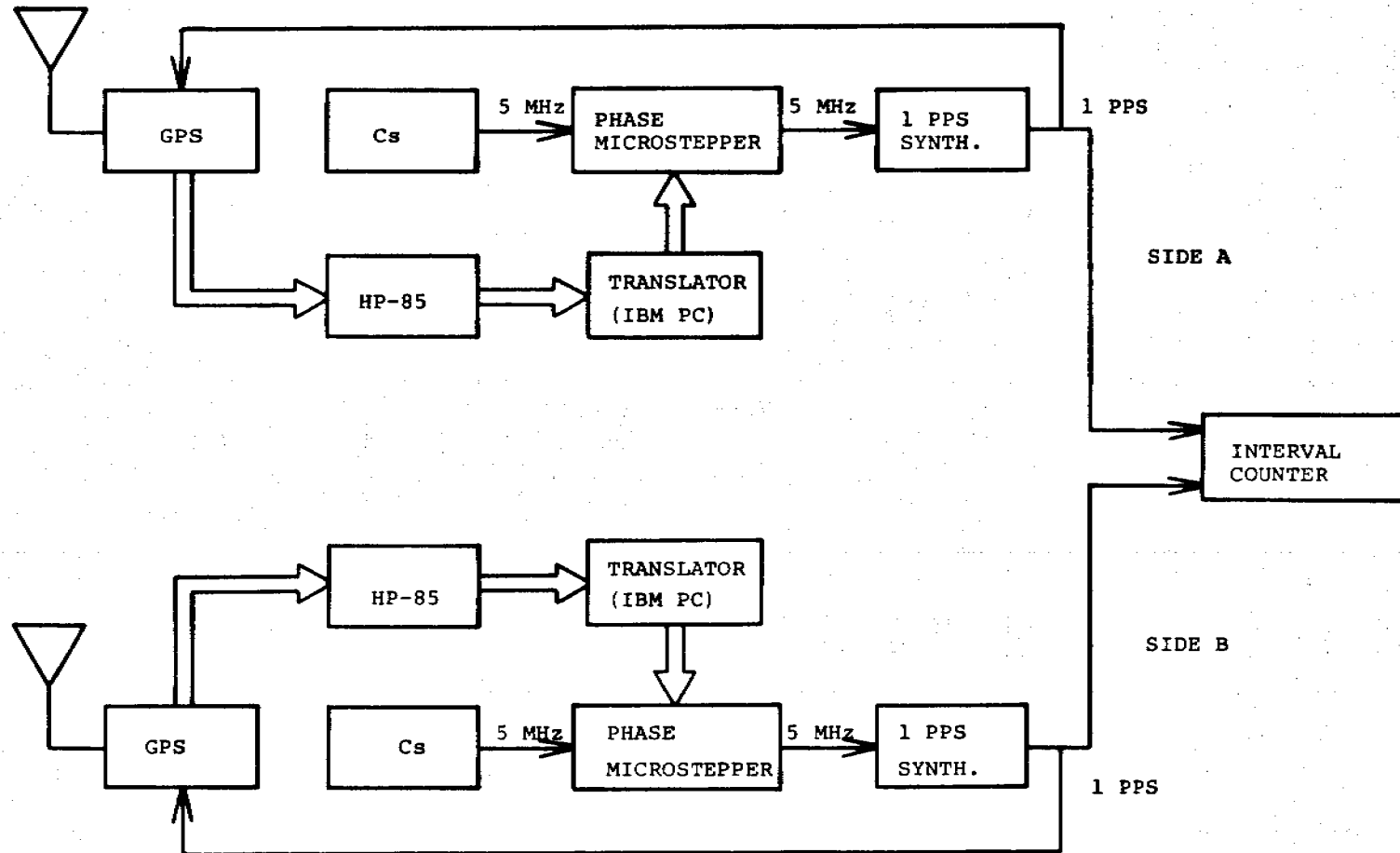

In actual setup Side A and Side B shared HP-85, IBM-PC, and GPS antenna.

Figure 3.

QUESTIONS AND ANSWERS

JOHN DICK, JET PROPULSION LABORATORY: What you would expect from this sort of system depends on the algorithm that you have in the computer. Can you characterize that in terms of an integration time or something else, besides the number which you did give, the slew rate.

MR. RODRIGO: It is a two state Kalman filter algorithm designed by Jim Barnes. The time constant parameters in it are taken to be very large, corresponding to short time constants at the start. The algorithm just goes about learning what an appropriate time constant is. When it starts, you are talking about time constants on the order of the data interval, 15 seconds or so. By the time it is finished the algorithm has decided what an appropriate time constant is. I don't really have an answer for what that number is.