



**OPTIMIZED ROBUST ADAPTIVE NETWORKS IN SUPERVISORY
CONTROL AND DATA ACQUISITION SYSTEMS**

THESIS

Luis A. Oquendo Class, Capt, USAF

AFIT/GE/ENG/09-31

**DEPARTMENT OF THE AIR FORCE
AIR UNIVERSITY**

AIR FORCE INSTITUTE OF TECHNOLOGY

Wright-Patterson Air Force Base, Ohio

APPROVED FOR PUBLIC RELEASE; DISTRIBUTION UNLIMITED

The views expressed in this thesis are those of the author and do not reflect the official policy or position of the United States Air Force, Department of Defense, or the United States Government.

AFIT/GE/ENG/09-31

**OPTIMIZED ROBUST ADAPTIVE NETWORKS IN SUPERVISORY
CONTROL AND DATA ACQUISITION SYSTEMS**

THESIS

Presented to the Faculty

Department of Electrical and Computer Engineering

Graduate School of Engineering and Management

Air Force Institute of Technology

Air University

Air Education and Training Command

In Partial Fulfillment of the Requirements for the
Degree of Master of Science in Electrical Engineering

Luis A. Oquendo Class, BS EE

Capt, USAF

March 2009

APPROVED FOR PUBLIC RELEASE; DISTRIBUTION UNLIMITED

**OPTIMIZED ROBUST ADAPTIVE NETWORKS IN SUPERVISORY
CONTROL AND DATA ACQUISITION SYSTEMS**

Luis A. Oquendo Class, BS EE

Capt, USAF

Approved:

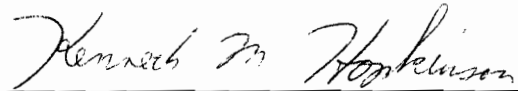

Dr. Kenneth M. Hopkinson
Committee Chairman

4 Mar 2009

Date

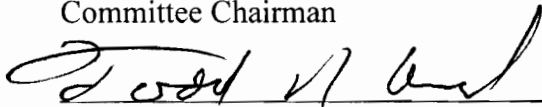

Maj. Todd R. Andel
Committee Member

4 MAR 09

Date

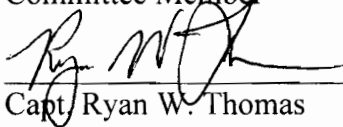

Capt Ryan W. Thomas
Committee Member

4 MAR 09

Date

Abstract

This thesis investigates the application of a Exponential Weighted Moving Average (EWMA) to be used as a memory buffer in conjunction with Special Protection Schemes (SPS) using the Electric Power and Communication Synchronizing Simulator (EPOCHS). It is proposed that using an SPS incorporating EWMA can compensate for the network layer lack of guarantee of packet delivery and provide for the stability and integrity of the power grid under a catastrophic event.

The performance of the proposed SPS is evaluated using a discrete event computer simulation developed using the NS2 network simulator and the Power System Simulator for Engineering (PSS/E) power system simulator. Performance and metrics evaluated in terms of the SPS's ability to properly calculate disturbance size and to react to the disturbance before the system reaches the minimum frequency threshold of 58.8 HZ and before 0.5 second threshold.

Experimental results indicate that the proposed SPS with EWMA can be successfully be applied to ensure power grid stability regardless of network background traffic. The results indicate that the proposed EWMA SPS ensures the protection of the grid. The EWMA SPS has a significant impact on performance when applied to a heavy background traffic network without router reservation enabling it to be stable without the additional hardware cost. Over all, in the tested configuration, the new SPS system successfully maintained steady state operation under all traffic intensities.

Acknowledgments

I would like to thank my thesis advisor, Dr. Kenneth Hopkinson, for providing the guidance and experience to keep me on track, yet promoted me the opportunity to pursue my ideas freely. In addition, I'd like to thank Dr. Rusty Baldwin and Dr. Michael Temple for their support.

I greatly appreciate the help of my colleagues Augustine Honore, Anthony Larweck and Ben Ramsey whose ideas and encouragement provided much of the inspiration behind my research. Their expertise and advice were invaluable.

Finally, I'd like to thank my wife and daughter for their unconditional support in order for me to reach my goal. Familia, thank you for taking care of me throughout these challenging times.

Table of Contents

	Page
Abstract.....	iv
Acknowledgments	v
Table of Contents.....	vi
List of Tables	x
I. Introduction	1
1.1 Motivation.....	1
1.2 Overview and Goals	2
1.3 Thesis Layout.....	2
II. Background and Literature Review	3
2.1 Introduction.....	3
2.2 Wide Area Measurement Systems Project	9
2.3 Special Protection Schemes	10
2.3. EPOCHS	15
2.4 Transport Layer Protocols	18
2.4.1 User Datagram Protocol.....	19
2.4.2 Transmission Control Protocol	20
2.5 Exponential Weighted Moving Average	22
2.6 Summary.....	23
III. Methodology.....	24
3.1 Introduction.....	24
3.2 Problem Definition	24
3.2.1 Goals and Hypothesis	24
3.2.2 Approach.....	25
3.3 System boundaries	26
3.4 System Services	27
3.5 Workload	28
3.6 Performance Metrics.....	28
3.7 Parameters.....	28
3.8 Factors.....	29
3.9 Evaluation Technique	31
3.10 Simulation Environment.....	31
3.11 Simulation Setup	33

3.11.1 Scenario 1 Simulation	33
3.11.2 Scenario 2 Simulation	33
3.11 Experimental Design	34
3.12 Analysis and Interpretation of Results	34
3.13 Summary	35
IV. Results and Analysis	36
4.1 Introduction	36
4.2 Architecture Model Validation	36
4.3 Results and Analysis of Performance Metrics	38
4.3.1 Analysis of Scenario 1	38
4.3.1.1 UDP without Router Reservation with Heavy Background Traffic	39
4.3.1.2 UDP without Router Reservation with Medium Background Traffic	40
4.3.1.3 UDP without Router Reservation with Light Background Traffic	42
4.3.2 Analysis of Scenario 2	43
4.3.2.1 UDP with Router Reservation with Heavy Background Traffic	43
4.3.2.2 UDP with Router Reservation with Medium Background Traffic	45
4.3.1.3 UDP with Router Reservation with Light Background Traffic	46
4.3 Overall Analysis	48
4.4 Summary	49
V. Conclusion	50
5.1 Introduction	50
5.2 Conclusions of Research	50
5.3 Significance of Research	51
5.4 Recommendations for Future Research	51
5.5 Summary	52
Appendix A. 99% Confidence Interval Plots of the System Frequency	53
A.1 99% Confidence Interval for Heavy Traffic without Router Reservation	53
A.2 99% Confidence Interval for Medium Traffic without Router Reservation	54
A.3 99% Confidence Interval for Light Traffic without Router Reservation	55
A.4 99% Confidence Interval for Heavy Traffic without Router Reservation	56
A.5 99% Confidence Interval for Medium Traffic without Router Reservation	57
A.6 99% Confidence Interval for Light Traffic without Router Reservation	58
A.7 99% Error squared of Without SPS with EWMA and SPS With EWMA	59
Appendix B. Procedures for Setting up and Running Simulations	60
Procedures	60
Bibliography	65

List of Figures

Figure 1. Interconnections of the NERC for the Contiguous United States [6]	4
Figure 2. NERC Regions for the Contiguous United States [7]	4
Figure 3. State Status of Restructuring as of February 2001[10]	7
Figure 4. Western Power Grid Model Comparison of the August 10, 1996 System Breakup [14]	10
Figure 5. SPS Effectiveness Index [15]	11
Figure 6. Dependability Index [15].....	12
Figure 7. False Operation Rate Index [15].....	12
Figure 8. Estimated Cost of SPS Failure [15].....	13
Figure 9. Estimated Cost of Unnecessary SPS Operation [15].....	14
Figure 10. EPOCHS Simulation System [3].....	16
Figure 11. Placement of Agent Based IEDs on a Utility Intranet [22]	18
Figure 12. Transport Layer Protocol Service on the Internet Protocol Stack [24]	19
Figure 13. UDP Segment Format [24]	20
Figure 14. TCP Segment Format [24]	21
Figure 15. IEEE 145-Bus 50 –Generator Test Case [28].....	26
Figure 16. EPOCHS System	27
Figure 17. System Undergoes an Unacceptable Frequency Decrease [17]	37
Figure 18. Validation of SPS Algorithm[17].....	37
Figure 19. System Frequency Response under Heavy Traffic without Router Reservation	40

Figure 20. System Frequency Response under Medium Traffic without Router Reservation	41
Figure 21. System Frequency Response under Light Traffic without Router Reservation	43
Figure 22. System Frequency Response under Heavy Traffic with Router Reservation .	45
Figure 23. System Frequency Response under Medium Traffic with Router Reservation	46
Figure 24. System Frequency Response under Light Traffic with Router Reservation ...	48

List of Tables

Table	Page
Table 1. Percentages of Most Common SPS Type [15]	Error! Bookmark not defined.
Table 2. Background Traffic Rates [3]	Error! Bookmark not defined.
Table 3. Test Matrix Performed Per Repetition.....	Error! Bookmark not defined.

OPTIMIZED ROBUST ADAPTIVE NETWORKS IN SUPERVISORY CONTROL AND DATA ACQUISITION SYSTEMS

I. Introduction

1.1 Motivation

With the growing population of the United States and its subsequent demand for electrical power, the demands on the electrical power grid are growing at unprecedented rate. This high demand for energy is making it essential for the power community to be able to share information in a more efficient manner in order to prevent blackouts like the one that occurred on 14 August 2003. The use of the Electric Power and Communication Synchronizing Simulator (EPOCHS) system could provide great benefits to the private industry as well to the Department of Defense (DoD) power systems infrastructure by allowing simultaneous synchronous simulation of communication and power system simulators to better understand the power grid under anomalous situations. Supervisory Control and Data Acquisition (SCADA) systems and the power grid infrastructure have recently been the focus of attention given the recent disclosure of potential cyber attacks against it [1], [2]. Applying Special Protection Schemes like the one used by the EPOCHS systems could provide a solution not only to cyber attack, but to possible cascading failures typical to power system on current high load demands. Utilizing an Internet-like architecture to implement such back up and communication system is likely to be the most logical solution to providing a power grid intranet.

Previous work related to the EPOCHS SPS Scheme has limited robustness under high background utility intranet traffic present while the system failure occurred. High background utility intranet traffic caused a significant amount of packets to get dropped or lost, thus hindering the EPOCHS SPS's capability to properly calculate the power

disturbance and response time [3]. The deficiency of the EPOCHS SPS to properly react to this disturbance under medium to high background traffic suggests the need for an algorithm to compensate for network unreliability.

1.2 Overview and Goals

The goal of this research is to develop an SPS to ensure power system stability and integrity. The previously studied SPS did not react quickly enough to prevent system instability under medium to heavy network traffic conditions. It is hypothesized that this deficiency can be corrected by incorporating a buffer in the form of EWMA into the load and generator SPS agents to compensate for packet loss due to network traffic conditions. EWMA will enable the main SPS agent to predict with more precision the amount of power generation to reject and load demand to shed. This buffer will allow for some degree of packet loss due to network traffic condition and still provide accurate information of the initial system disturbance.

1.3 Thesis Layout

This chapter introduces the research topic and provides the motivation behind the effort. In Chapter 2, background information and fundamental concepts are presented as well as recent work in the topic area. Chapter 3 outlines the methodology used to carry out the experiments. Chapter 4 provides discussion and analysis of the experimental results. Chapter 5 draws conclusions about the results and offers areas for future research.

II. Background and Literature Review

2.1 Introduction

On September 4, 1882, the Thomas Edison's Pearl Street electricity generating station was introduced in New York City [4]. It evolved from gas and electric carbon-arc commercial and street lighting systems. It introduced the power industry by featuring the four key elements of a modern electric utility system. It featured reliable central generation, efficient distribution, a successful end use, and a competitive price [5]. From 1901 through 1932, growing economies of scale hastened growth and consolidation in the electric utility industry, as well as the beginnings of State and Federal regulation. The Federal Government became a regulator of private utilities in the 1930s; it also became a major producer of electricity beginning in this period. The 1933-1950 period was also characterized by continued growth of the industry, increased consolidation and interconnection, and increasing economies of scale. During the 1940 to 1950 increase power demand provided for more utility companies to be created due to World War II and expansion of the electric grid to rural farming areas. The era post World War II provided for a dramatically increase for the demand and supply of electrical power. New technologies like nuclear power were introduced making it possible to provide cheaper electricity. This also led for the increase of small private power expansion replacing Federal power growth [5]. This unmeasured growth encountered a dramatic catastrophe when in 1965 a major Northeastern power blackout occurred [5], raising concerns about the reliability of the power grid. In response to this, huge interconnected (see Figure 1), interdependent power networks were developed to provide for the formation of regional

reliability councils, and the North American Electric Reliability Council (NERC) (see Figure 2) to promote the reliability and adequacy of bulk power supply.

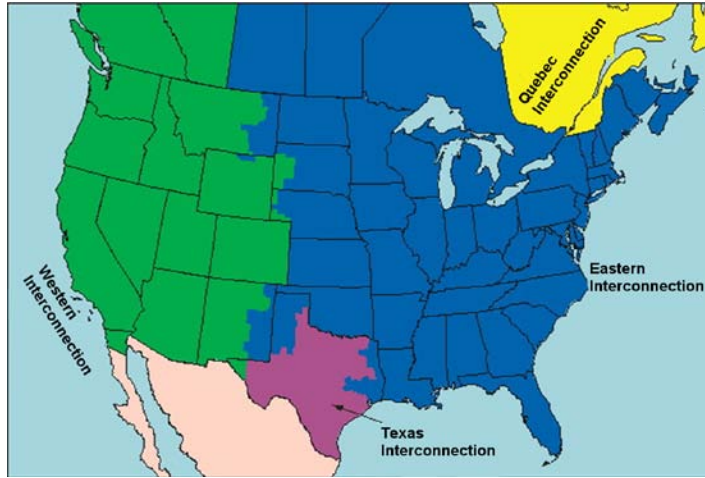

Figure 1. Interconnections of the NERC for the Contiguous United States [6]

North American Electric Reliability Corporation (NERC) Regions

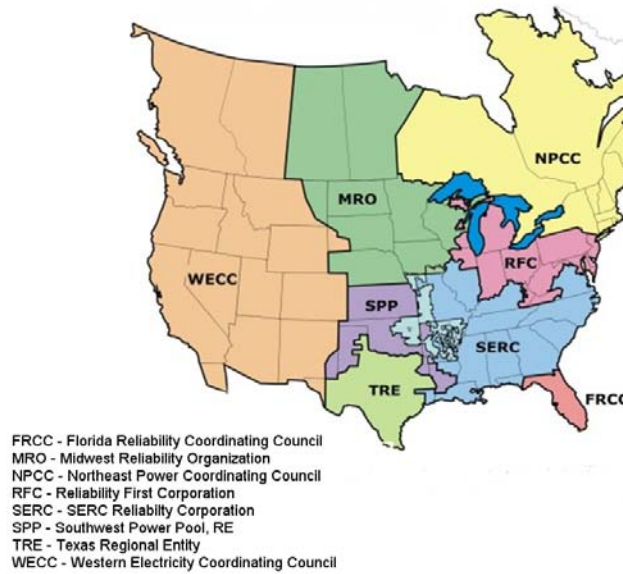

Figure 2. NERC Regions for the Contiguous United States [7]

Despite the major blackout of 1965, the power industry continued to expand, producing more energy for the perpetual demand for energy. These expansions

continued up until the 1970s while the electric utility industry moved from decreasing unit costs and rapid growth to increasing unit costs and slower growth. Major factors contributing to the slowdown of the electric utility industry during the 1970s were general inflation, increases in fossil-fuel prices caused by the OPEC embargo of 1973 and the Iranian revolution of 1979, environmental and conservation legislations (Clean Air Act of 1970 and The Energy and Coordination Act of 1974) which led to higher operating cost, and problems in the nuclear power industry which resulted in the closure of 5 nuclear reactors followed by the cancellation for new nuclear reactors and since 1978 there has not being installed in the US [5].

While demand kept increasing, the production of energy slowed down. This resulted in stress on the existing power grid and to the economy of the utilities making them increase the charge per kilowatt hour dramatically. Capital costs for electric utilities rose for energy production from about \$150 per kilowatt in 1971 to over \$600 after 1976 [5]. The increase cost of energy led to Congress passing the Public Utility Regulatory Policies Act of 1978, which laid the groundwork for deregulation and competition by opening wholesale power markets to nonutility producers of electricity. Congress voted to promote greater competition in the bulk power market with the passage of the Energy Policy Act of 1992. The Federal Energy Regulatory Commission (FERC) implemented the intent of the Act in 1996 with Order 888 [8], which addresses equal access to the transmission grid for all wholesale buyers and sellers, transmission pricing, and the recovery of stranded costs and Order 889 [9] which requires jurisdictional utilities that own or operate transmission facilities to establish electronic systems to post information about their available transmission capacities. The main

purposes of these Orders are to “remove impediments to competition in wholesale trade and to bring more efficient, lower cost power to the Nation’s electricity customers” The FERC orders required open and equal access to jurisdictional utilities’ transmission lines for all electricity producers, thus facilitating the States’ restructuring of the electric power industry to allow customers direct access to retail power generation.

As a result of the Federal and State initiatives, the electric power industry is transitioning from highly regulated, local monopolies which provided their customers with a total package of all electric services and moving towards competitive companies that provide the electricity while utilities continue to provide transmission or distribution services. States are moving away from regulations that set rates for electricity and toward oversight of an increasingly deregulated industry in which prices are determined by competitive markets. To be more specific, almost half of the States have passed major legislation and/or regulations to restructure their electric power industry (see Figure 3).

The States, which regulate distribution services and retail rates for electricity within their borders, each decides whether deregulation is in their best interest.

The lack of situational awareness led to the August 2003 in the northeastern United States. As temperatures in the northeast United States during the week of 11- 15 August 2003 were considered hot as compared to normal fall temperatures. As temperature rose to a hot 88 °F, energy demands dramatically increased due to people turning air conditioning units on. This demand was established to be 20% [12] higher peak load than the forecasted for First Energy (FE), Energy Company responsible for the generation, transmission and distribution of electricity in the Ohio, Pennsylvania and New Jersey area. In addition to high energy demand, three unplanned outages occurred composed of two line trips and one generator going offline. All of these factors combined to produce the ideal scenario for what happened next. August 14, 2003 at 15:05 EDT a massive power outage initiated in the Ohio region and cascaded throughout parts of the Mid and Northeastern United States and Ontario affecting over 50 million people and disrupting national critical infrastructure. Estimated damages of this accidental blackout to our economy are in the 7 to 10 billion dollars with a death toll of 11 persons [1]. Following this incident, security proponents [1] indicate that a terror-induced blackout could prove significantly more costly and have potentially debilitating impacts on the affected region as well as the entire country. The August 2003 blackout, even accidental, reinforces the importance of this research to try to develop the next generation utility intranet standards with the required quality of service and robustness needed to provide power system stability and integrity. The following section will present some of the technologies and effort that has been made towards building the utility intranet.

2.2 Wide Area Measurement Systems Project

The Wide Area Measurement System (WAMS) Project was a combined effort between Department of Energy with the Bonneville Power Administration and the Western Area Power Administration to assess the long-term research and development needs of dynamic information required for the future of electric power system operation [13]. By laying down the initial groundwork it provided guidelines for a better path to enhanced power utility operation to served new customer demand and increase generation competition, while contributing to increased system efficiency and capacity. One of the major contributions of the WAMS project was the ability to extract synchronized data from the Phasor Measurements Units (PMU) in order to enhance the ability of system engineers and planners to design and control system operations, and better manage their assets (see Figure 4). Another goal of the WAMS project is to provide for better modes in order to predict system performance under any circumstance. An example of this was when the WAMS project was able to capture real time data regarding a power grid breakup that occurred in August 10, 1996. The WAMS was key to understand the failure of the Western power system due to then current invalid power grid performance models. As stated by Pacific Northwest National Laboratory, U.S. Department of Energy in [14] : “One of the greatest benefits realized was that the data contained precursors, which if had been properly analyzed, could have allowed proactive switching of generating resources. This could have either eliminated or drastically reduced the impact of the initial line failure.”

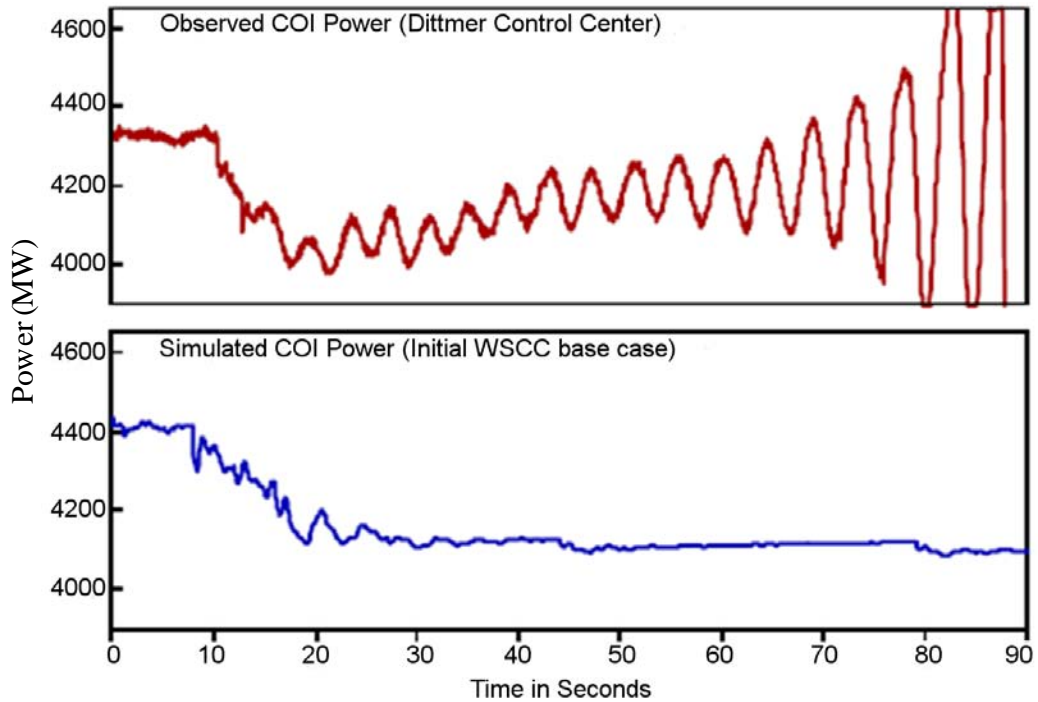

Figure 4. Western Power Grid Model Comparison of the August 10, 1996 System Breakup [14]

Currently, due to its success in the Western Area Power Administration, the WAMS project is being deployed in the US Eastern Interconnection through the Eastern Interconnection Phasor Project and is facilitating joint task teams to conduct emergency planning and activities.

2.3 Special Protection Schemes

An important role to protect utility communications is to enable improved Special Protection Schemes (SPS) to protect the grid from catastrophic events. The system responsible for the protection of the power system stability is called a Special Protection Scheme. Special Protection Schemes as defined by [15] are schemes designed to detect power system condition that are known to cause system instability and take a predetermined action to counteract the condition in a controlled manner. As expected,

failure of the SPS to accurately detect the defined conditions or inability to respond with the remedial action in the appropriate timeframe could potentially lead to catastrophic events as those of the August 2003 blackout. Therefore, the dependability of the SPS is an important factor. Study shows that with the increased in technology and understanding of SPS schemes the effectiveness and dependability of such schemes has increased (see Figure 5 and 6). In the survey performed by Anderson [15], he measured the Effectiveness, Dependability and Unnecessary Operation rate Indexes given the two most used SPS scheme type (Generation Rejection and Load Rejection) and results are shown in Figures 5 to 7.

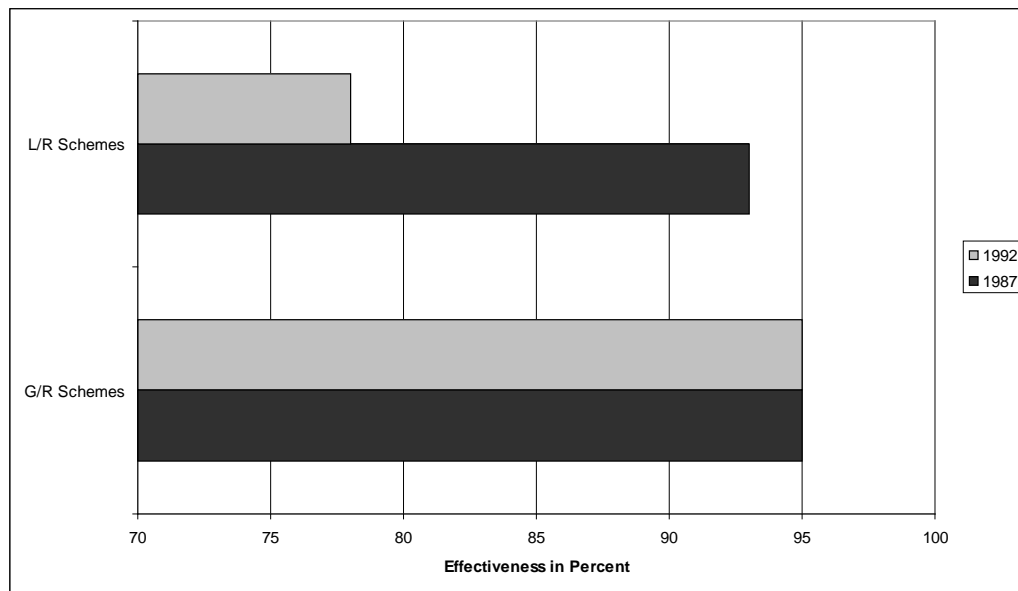

Figure 5. SPS Effectiveness Index [15]

Note: G/R is generation rejection scheme and L/R is load rejection scheme

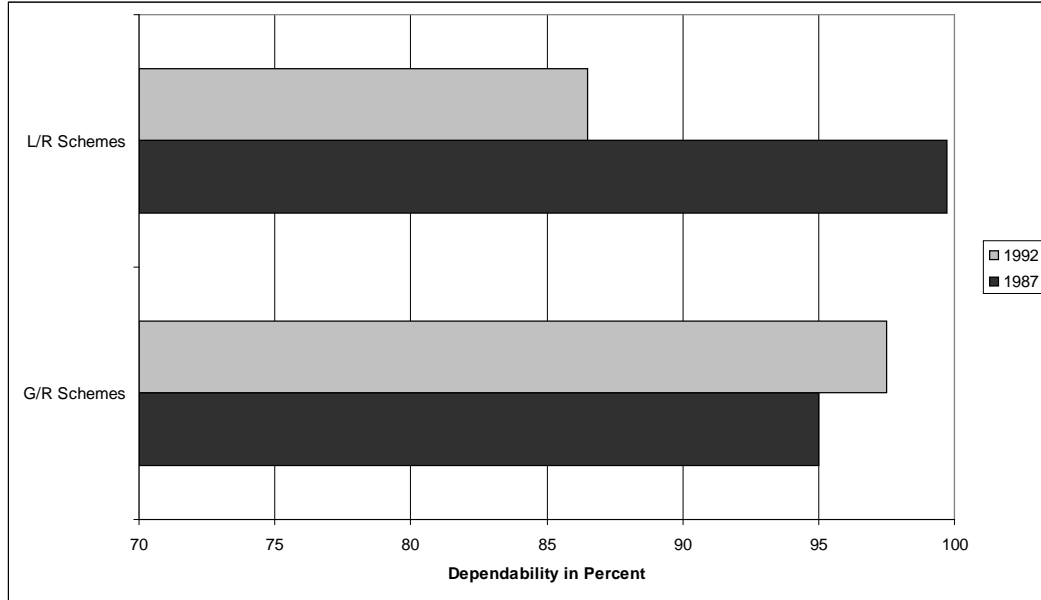

Figure 6. Dependability Index [15]

Note: G/R is generation rejection scheme and L/R is load rejection scheme

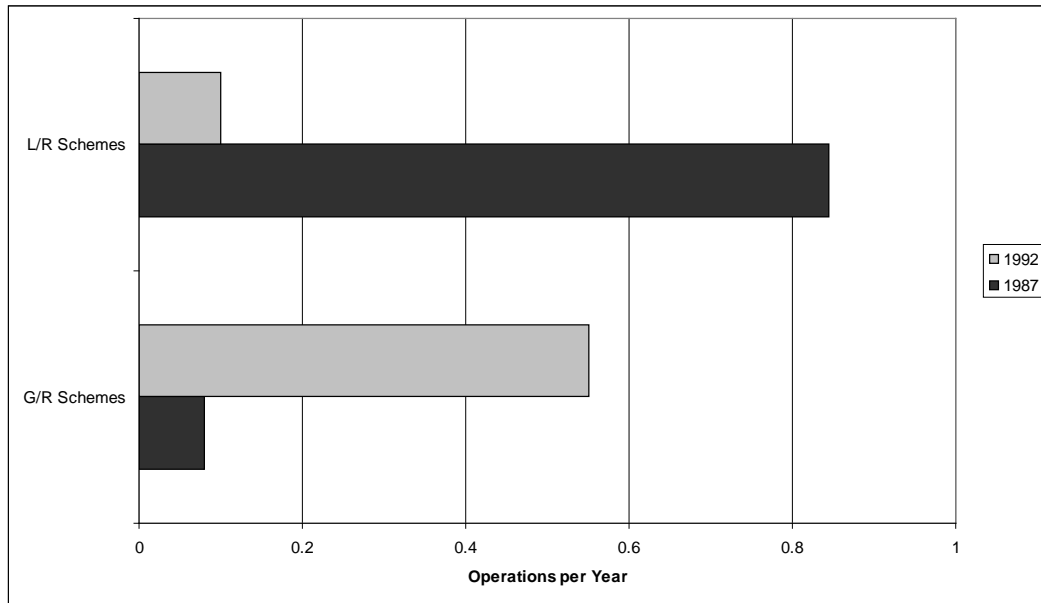

Figure 7. False Operation Rate Index [15]

Note: G/R is generation rejection scheme and L/R is load rejection scheme

In the report produced by Anderson [15], he expresses the cost incurred by utilities in case of SPS failure is estimated to be greater than \$100K for approximately 75% (see Figure 8) of the occurrences. While the estimated cost for false SPS deployment is less than \$100K for 72% (see Figure 9) of the occurrences. Thus it is to the utilities best interest to deploy SPS in order to lower operation cost and to meet contractual power transaction.

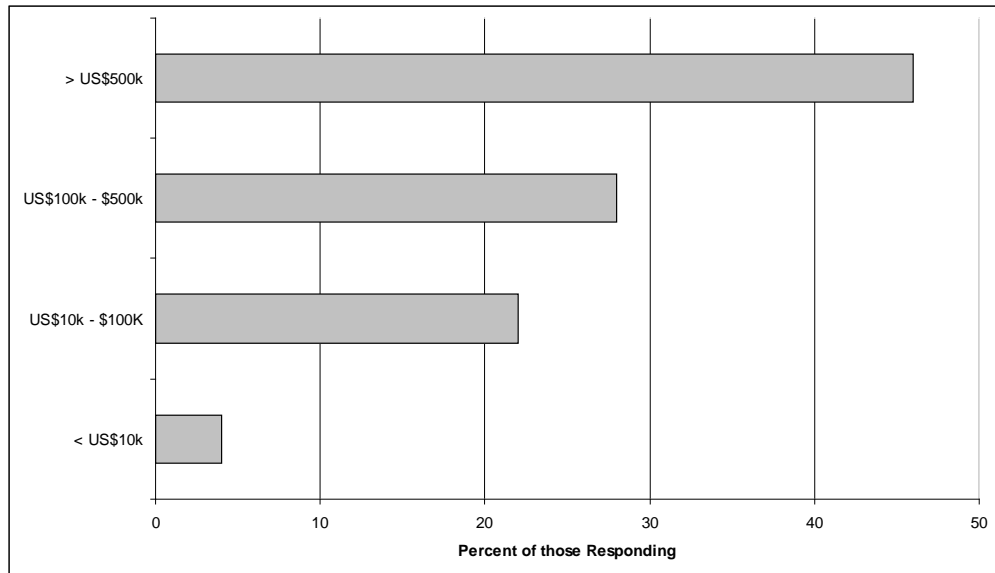

Figure 8. Estimated Cost of SPS Failure [15]

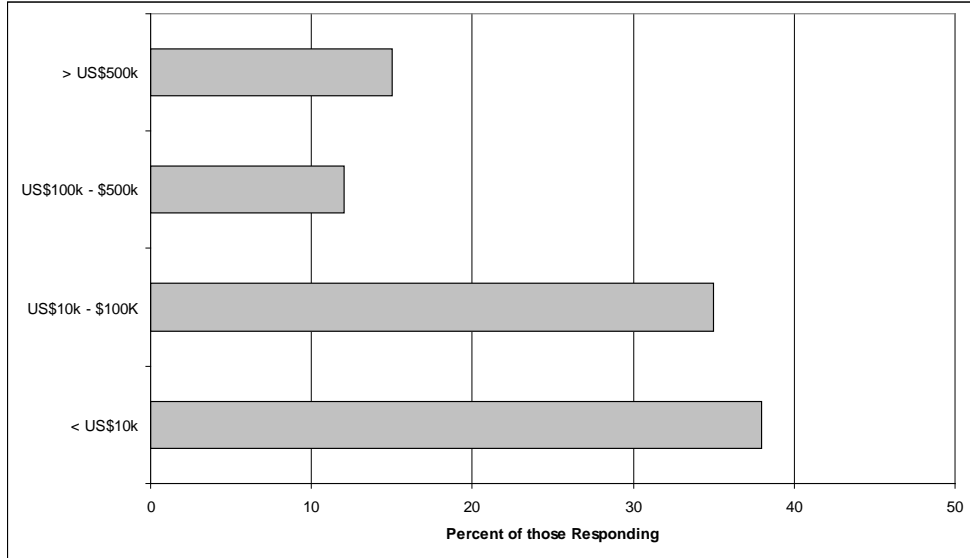

Figure 9. Estimated Cost of Unnecessary SPS Operation [15]

A recent study done in 2002 by Zima [16] provides that the majority of the utilities in the US are employing some type of SPS in their current operations. Also, the report by Anderson [15] provides that of those SPSs in the utility companies surveyed, 29% of the SPS system were installed during the 1970s, 46% of the SPS were installed in the 1980s and 14% of the SPS were installed in the early 1990s. It was discovered that in general, the predominant SPS scheme type system uses generation rejection, load rejection underfrequency load shedding, and/or a combination of these schemes for protection action. Table 1 provides a detailed view of the different SPS schemes used and the percentage of usage.

Table 1. Percentages of Most Common SPS Type [15]

Type of SPS	Percentage
Generator Rejection	21.6
Load Rejection	10.8
Underfrequency Load Shedding	8.2
System Separation	6.3
Turbine Valve Control	6.3
Load and Generator Rejection	4.5
Stabilizers	4.5
HVDC Controls	3.6
Out-of-Step Relaying	2.7
Discrete Excitation Control	1.8
Dynamic Braking	1.8
Generator Runback	1.8
Var Compensation	1.8
Combination of Schemes	11.7
Others	12.6

These percentages and the year of installation are important factors since the WAMS project is trying to interconnect all of the utilities and their infrastructure to the proposed intranet. The study done by Anderson [15], shows that a major infrastructure upgrade will need to happen in order to bring the SPS systems to integrate to the intranet.

2.3. EPOCHS

The electric power and communication synchronizing simulator (EPOCHS) is a simulation system that combines and synchronizes Commercial Off The Shelf (COTS) simulators in order to provide for an understanding of a power system that uses computer network communication to operate and control their grid. As described by Hopkinson in [17], the simulators that are linked by EPOCHS are General Electric's (GE) Positive Sequence Load Flow (PSLF) Software[18], Seimen's PSS/E electromechanical transient simulator [19], Power Systems Computer Aided Design (PSCAD) Electromagnetic Transients including DC (PSCAD/EMTDC) electromagnetic transient simulator [20], and

NS2 [21]. The way in which EPOCHS communicate with every simulator is through the use of agents that are located on each node of the system. These agents have the ability to communicate with one another and the ability to perform power grid related actions through the use of intelligent electronic devices (IEDs). As depicted in Figure 10, a simulation agent headquarters (AgentHQ) presents a unified view to agents and acts as a proxy between the software agents, network simulator, and the power simulator. Most importantly, the runtime infrastructure poses as moderator/simulation synchronizer, orchestrating the harmonious interaction of all messages sent by the agents from the entire simulator system.

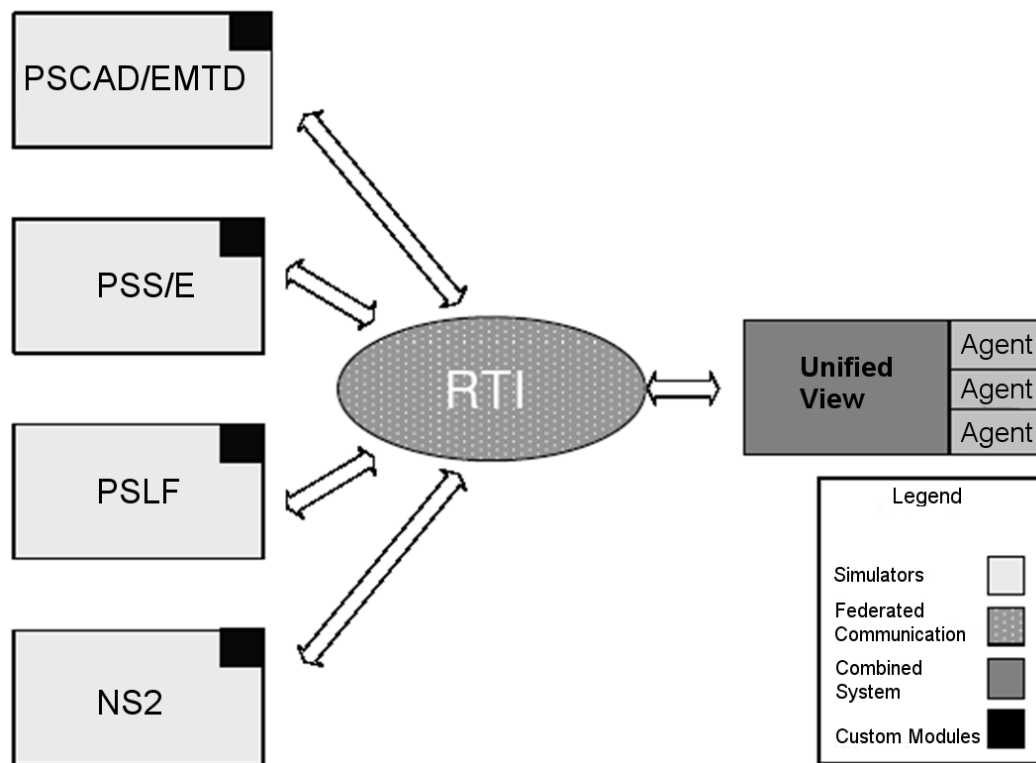

Figure 10. EPOCHS Simulation System [3]

The SPS used by EPOCHS, employs the algorithm

$$P_d = P_a + \Delta P_e (\omega_{0+} - \omega_{0-}, u_{0+} - u_{0-}) [17]$$

for the purpose of calculating system shortfall based on the size of a power system disturbance. Where, P_d is the size of the disturbance and is equal to the system accelerating power, P_a , which is proportionate to the change in the system's frequency, plus the change in electrical power demand ΔP_e due to the variation in frequency and voltage. The time immediately before a disturbance is represented by $0-$ and the time immediately after a disturbance is denoted by $0+$. P_d is the key to determining the amount of generation that has been lost. Generation and load agents must send data points to the SPS main agent and action taken within a fraction of a second to prevent power system instability [17].

As explained by Roberts in [3], "In order to support the operation of software agents on the power grid a hardware device is needed that has the computational, communication, and I/O capabilities to meet agent demands. EPOCHS uses agent based intelligent electronic devices (IEDs) for this purpose so software agents can perform the necessary protection and control functions needed." Figure 11 provides a representation of the deployment of such IEDs in the proposed utility intranet.

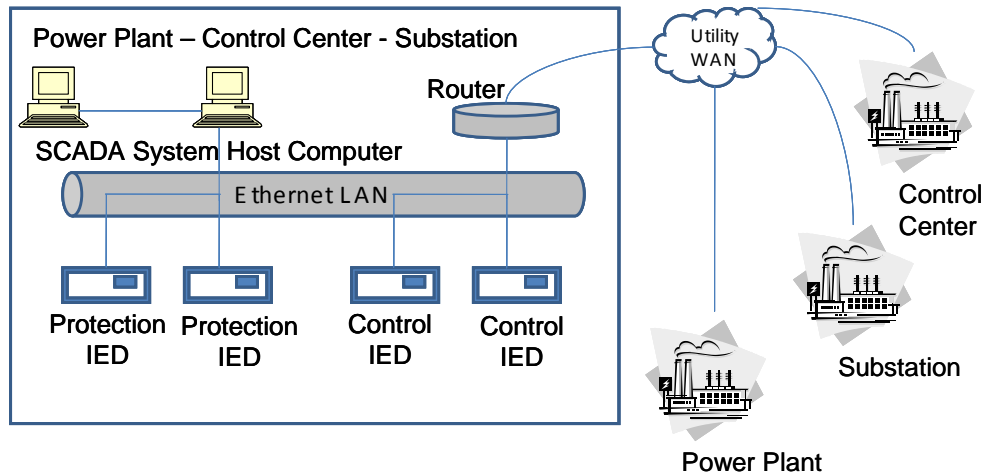

Figure 11. Placement of Agent Based IEDs on a Utility Intranet [22]

2.4 Transport Layer Protocols

Since EPOCHS provides for an effective way to combine NS2 with PSS/E to investigate power grid performance involving network communication, it is important to understand the protocols used to send the critical system information through the network infrastructure. Due to the enormous cost involving the development of a network infrastructure from scratch and the standard proposed by IEC 61850 standards [23], it is certain that the future utility intranet will consist on already established COTS technology. The most widely known and used of these technologies would be the internet. As part of the internet protocol stack, the transport layer provides for logical end-to-end communication between processes running in two different hosts on the network. The interaction of the transport layer and its position in the internet protocol stack is shown in Figure 12. The transport layer breaks the application layer messages into segments and sends them to the network layer to be delivered to the end host. When the segment gets to the end host transport layer, the transport layer reassembles the segment into messages and delivers them to the application layer for processing.

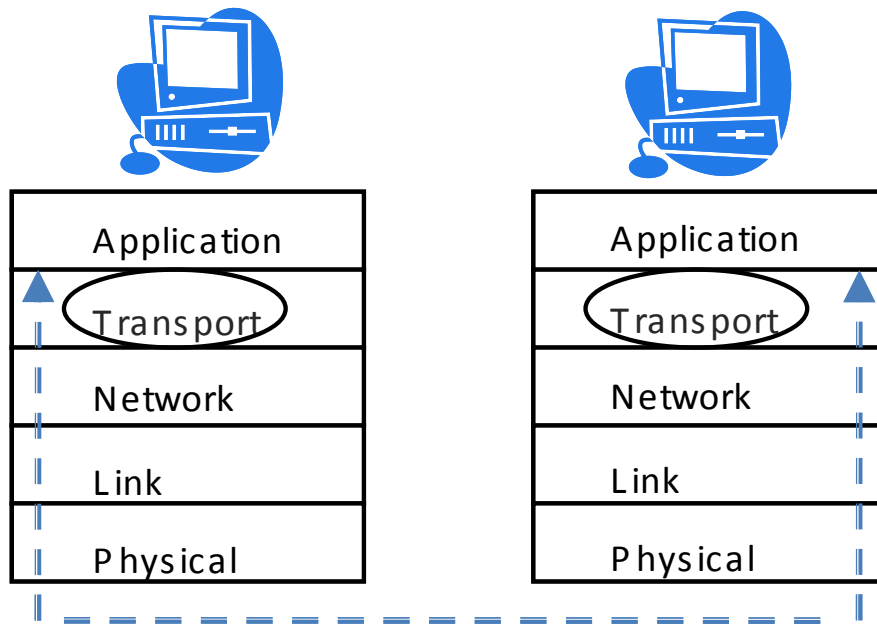

Figure 12. Transport Layer Protocol Service on the Internet Protocol Stack [24]

Specifically regarding the internet, the two major transport layer protocols used are Transmission Control Protocol (TCP) or User Datagram Protocol (UDP) [24]. In essence, they both have pros and cons to each other however, in the end the protocol used in the transport layer will depend on the application data loss, timing and bandwidth requirements. In the next section we explained TCP and UDP concepts to provide for a better understanding the final election for a utility intranet protocol that will be simulated through EPOCHS, NS2 and PSS/E.

2.4.1 User Datagram Protocol

UDP is one of the predominant transport layer protocols used in today's internet age. As described by Kurose in [24], UDP is a “no frills, barebones internet transport protocol” which provides “best effort” transport layer service. Since UDP uses no handshaking process between sending and receiving transport layer entities, it is said to be a connectionless protocol. It's service is simple and behaves by taking the messages

from the application layer and converting them into UDP segments. UDP attaches to the application layer message a source and destination port number, length, and a checksum fields into the header of the segment. The format of the UDP segments is a standard under the RFC 768 where detailed specifications are available.

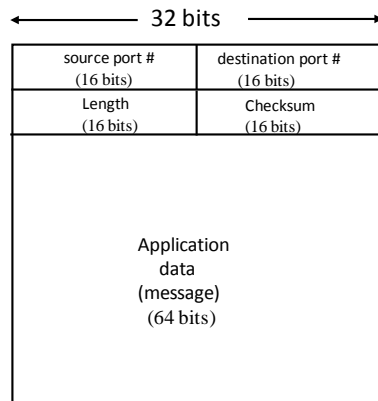

Figure 13. UDP Segment Format [24]

The sending host transport layer sends this segment to the network layer for it to deliver it down the internet stack and back up to the destination host. When the segment reaches the receiving host transport layer, UDP uses the destination port to get it to the appropriate port for it to send the message to the application layer. Of course, all of this network transmission is conducted in a best effort without any guarantees. Regardless of the lack of guarantee, UDP proves to be useful for data loss tolerant applications and for real time application since it doesn't possess congestion control mechanisms like will be discussed with TCP.

2.4.2 Transmission Control Protocol

TCP is the most used transport layer protocol in the internet. As described by Kurose in [24], TCP is a connection-oriented protocol since before one application

process can begin to send data to another, the two processes must first “handshake” with each other. This implies that an introduction is required as part of the communication section. While this provides for some degree of error correction capability for the data, it also heavily increases the overhead required to transmit data. The attractiveness of TCP is that it uses flow control, or congestion control, in order to ensure that sender will not overflow the receiver by matching the data sending speed to that of the receiver. Looking at the TCP segment format provides for a better understanding of its difference with UDP.

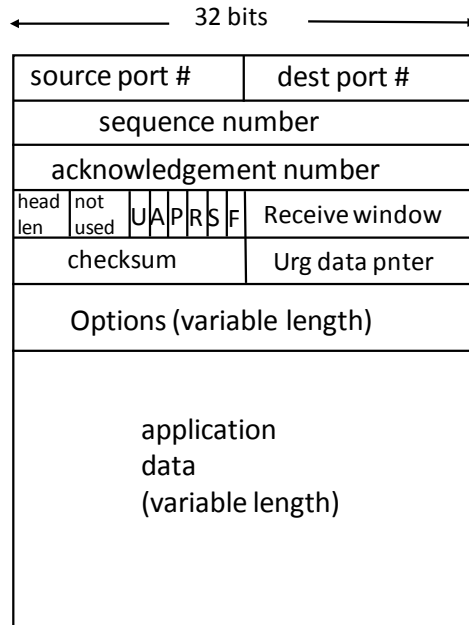

Figure 14. TCP Segment Format [24]

As seen in Figure 14, the use of TCP as the transport layer protocol increases the overhead to send data by including that additional sequence and acknowledgment number, receive window, header length, options and flag fields.

Even though TCP provides for added reliable transfer of data, it was shown in [17] and [3] that TCP does not provide for quick response to properly operate the SPS; thus, TCP is rejected as candidate protocol in this thesis. In the same studies, UDP is shown to have potential, but lack reliability to deliver data in high background traffic scenarios. It is then needed compensate UDP lack reliability with a suitable algorithm that provides integrity to the SPS while maintaining UDP quick responsiveness.

2.5 Exponential Weighted Moving Average

The Exponential Weighted Moving Average (EWMA) is a statistic for monitoring the process that averages the data in a way that gives less weight to data as time progresses. The equation for EWMA is

$$EWMA_t = (1 - \alpha)(EWMA_{t-1}) + (\alpha)(Y_t), \text{ for } t = 1, 2, \dots, n.$$

where the weight factor α , which sometimes is referred as a smoothing factor, is a number between 0 and 1 and is usually expressed as a percentage, $EWMA_0$ is the mean of the historical data or the intended target and Y_t is the observation from a system at time t . It is important to notice the influence of the weight factor upon $EWMA_t$. A weight factor of 0 would produce a EWMA of $EWMA_0$ not taking into account any data values obtained from the system as time progresses. Similarly, a weight factor of 0.5 would yield a $EWMA_t$ that is unbiased containing half of the information of old data value and the other half representing new data values as time progresses. In the other end of the spectrum a weight factor of 1 would produce EWMA that would contain only information of new data values entering the system obtained as time progresses. Thus the weight factor can be viewed as the depth memory or in our case system buffer that the data contains from previous data value. In addition to the $EWMA_t$, an upper and lower

bound for the EWMA known as the control limits can be established using Lucas and Saccucci [25] formula. The equation for the control limits are:

$$UCL = EWMA_0 + ks_{EWMA} \text{ and } LCL = EWMA_0 - ks_{EWMA},$$

where “k” is usually set to 3 and “s” is the historical standard deviation of the data.

The EWMA presents itself as an effective way of establishing a system memory buffer without the need of storing data values to improve system reliability under any level of utility background traffic present. In the case of Batra et al. [26], where EWMA algorithms were used to reduce packet loss in a network integrated card by adjusting threshold values in a timely manner and adapting to network traffic conditions. Another example of EWMA can be seen in Kumar, et al. [27] where a weighted prediction region based cost function was developed for selecting an item to be replaced from disk cache. In our case, a EWMA algorithm is used to compensate for UDP lack of reliability.

2.6 Summary

This chapter presented background information, fundamental concepts and recent research in the area of power systems and utility intranet concept. Basic knowledge on EPOCHS, UDP, TCP and SPS was discussed. Finally, EWMA was explained and presented as the potential solution to compensate for UDP reliability deficiencies for reliable data transfer.

III. Methodology

3.1 Introduction

This chapter presents the methodology used to evaluate a new SPS algorithm against a previously created SPS, which originally was created by Hopkinson, et al. [17] and further explored under various levels of communication stress [3]. The performance of these algorithms is compared using the EPOCHS simulation platform [17]. The chapter begins by describing the problem definition, goals and hypothesis, and the approach. Next, the system and its services are described followed by a detailed description of the workload, performance metrics, parameters, and factors. Then, the evaluation technique and experimental design are discussed. Finally, the technique used to analyze and interpret the data is covered.

3.2 Problem Definition

3.2.1 Goals and Hypothesis

The goal of this research is to develop a SPS to ensure power system stability and integrity. A previously developed SPS system developed and tested using the EPOCHS simulation platform didn't react quickly enough to prevent system instability under medium to heavy utility intranet background traffic conditions. It is hypothesized that this deficiency can be corrected by incorporating a buffer in the form of a EWMA into the load and generator SPS agents to compensate for packet loss due to competing network traffic and other network problems. The EWMA will enable the main SPS agent to predict with more precision the amount of power generation to reject and load demand

to shed. This buffer will allow for some degree of packet loss due to network traffic congestion and still provide accurate information of the initial system disturbance.

3.2.2 Approach

This research uses the IEEE 145-bus 50-generator test case as reference [28]. This test case power system has been modified to emulate the types of large power flows between areas that often occur in the north-south interconnect between California and Oregon in the Western U.S. power grid during hot days, which result in high demand to the south as people run their air conditioners. In the modified IEEE test case, the majority of the generators are located in the northeastern area, while the majority of the load is concentrated in the southeastern area. Figure 15 is a diagram of the power grid which describes the network topology. While the power system appears to be dense in the diagram, most of the northeast-southwest interconnects are low-voltage. Only a few key lines carry the majority of the power between regions. Various network utilization values, reservation types, transport layer protocols, and SPS agent traffic are submitted to the network. SPS agent traffic ranges from low traffic when no action is required and system is stable, to high traffic when a system fault occurs. Data is gathered on how the SPS reacts to different background traffic levels.

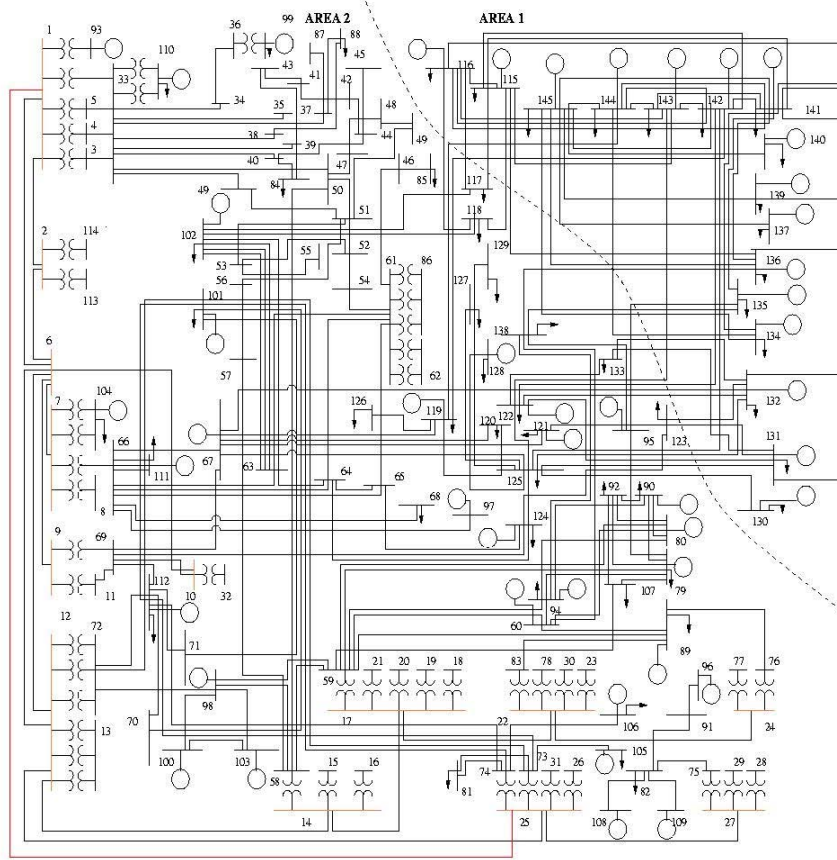

Figure 15. IEEE 145-Bus 50 –Generator Test Case [28]

3.3 System boundaries

The System Under Test (SUT) is the EPOCHS simulator. It consists of the following components: load agents, generator agents, and the SPS agents. The component under test (CUT) is the SPS agents.

Workload parameters is the size of the power system disturbance. The system parameters consist of the background traffic, SPS agent used and the router reservation type. These parameters are discussed in more detail in Section 3.7. The metrics of the system consist of the overall system frequency and the mean minimum frequency response. A block diagram of the SUT is shown in Figure 16.

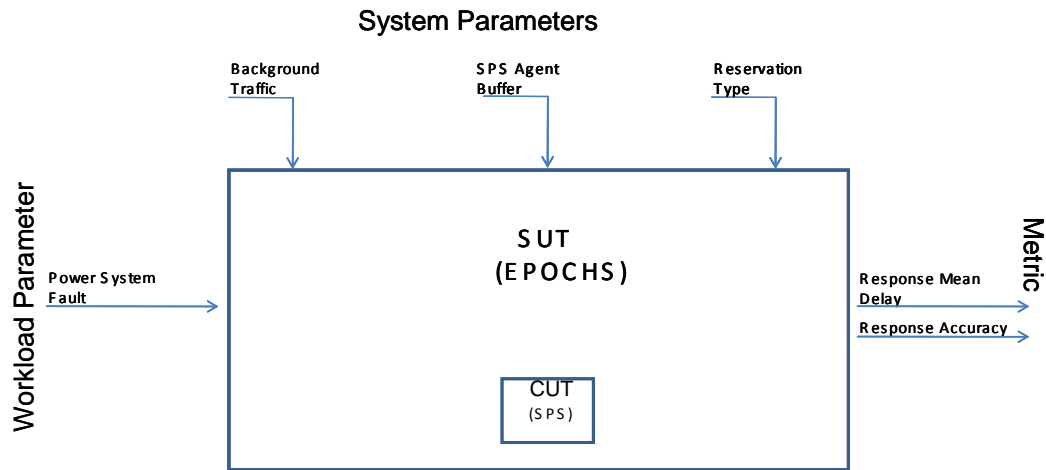

Figure 16. EPOCHS System

3.4 System Services

The special protection scheme determines if a fault in the power system needs correcting to reestablish system stability.

Outcomes

The possible outcomes of the SPS service are:

1. Data is received from the network and no action is required.
2. Data is received from the network action is required.
 - a. SPS analyzes the data, determines the amount of generation rejection and load shedding and sends a response back in the required time, avoiding a catastrophe.

- b. The SPS analyzes the data, determines the amount of generation rejection and load shedding and sends response back past the required time, not avoiding a catastrophe.
3. Data reached the SPS past the required time or data was corrupted.

3.5 Workload

The workload applied to the system under test is the power system fault involving an electric high voltage transmission line. This event will trigger alert message traffic to initiate and flow from the load or generator that initiated the fault to the main SPS agent.

3.6 Performance Metrics

The metrics that will be use to determine the SPS effectiveness will be SPS max frequency drop of 1.2Hz in system frequency and overall system frequency throughout simulation. As specified in the system standards [29], a 58.8 frequency threshold is established in order to ensure that the power system generators stay synchronous with each other. Accuracy is also an important metrics. Accuracy is measured by gauging the SPS ability to properly shed the required load and power when a system fault occurs in order to not reach the 58.8Hz minimum threshold.

3.7 Parameters

1. **Network Utilization** – network utilization affects the packet mean delay metric. The higher the network utilization, the higher mean delay. Additionally, high network utilization values increase dropped packets at network queues. This negatively affects the SPS ability to properly calculate the disturbance size.

2. **Background Traffic** – background traffic affects the packets mean delay metric. The higher the network utilization, the higher mean delay. Additionally, high background traffic increases network utilization values which increase dropped packets at network queues. This negatively affects the SPS ability to properly calculate the disturbance size.
3. **SPS agent buffer** – agent buffer size increases SPS performance. The SPS buffer holds the values from the SPS agents. This will ensure that some data can be delivered in case of dropped packets by the network.
4. **Reservation Type** – using a router reservation scheme decreases the packet mean delay and ensures packet delivery.
5. **Transport Layer Protocol** – the use of UDP versus TCP affects the mean delay metric due to the congestion control mechanism used in TCP.

3.8 Factors

1. **Background Traffic** – background traffic affects the packets mean delay metric. The higher the network utilization, the higher mean delay. Additionally, high background traffic increases network utilization values which increase dropped packets at network queues. Background traffic is set to three different levels: low, medium and high. The background traffic model in this research for a utility intranet is consistent with the one used by Roberts [3] shown in Table 1. For low traffic loads, background traffic consists of white sources only, medium traffic loads consist of light gray and white traffic sources, and heavy traffic loads will consist of dark gray along with light gray and white traffic sources.

Table 2. Background Traffic Rates [3]

Background Traffic Type	Distribution	Packet Size	Rate
SCADA	Constant	64 Bytes	1 every Seconds per Bus
Power Quality Data	Poisson	35 Bytes	1 every Seconds per Bus
UCA 2.0	Poisson	128 Bytes	1 every 20 Seconds per Bus
Power Trading	Constant	1,400 Bytes	1 every 2.2 Seconds per Bus
Internal Comm	Poisson	1 Mbytes	1 every 0.2 Seconds per Bus
Office - Substation	Poisson	64 Bytes	1 every 10 Seconds per Bus
Event Notification	Poisson	2.4 Mbytes	1 every 10 Seconds per Bus (Bus chosen at random)

2. **SPS agent buffer** – agent buffer size increases SPS performance by keeping traces of the previous data point. It is important to investigate what effects does increasing the buffer size have on the SPS performance. The buffer implemented by the use of an exponential weighted moving average to calculate the disturbance size instead of the actual data point. The exponential weighted moving average equation is

$$EWMA_t = (1 - \alpha)(EWMA_{t-1}) + (\alpha)(Y_t), \text{ for } t = 1, 2, \dots, n.$$

with α equal to 0.55 to give more importance to new values rather than previous collected values. The constant α is determined such that it provides increase fault detection and correction to all scenarios.

3. **Reservation Type** – the use of router reservation improves SPS agent traffic data to arrive at its destination by providing priority to system faults packets. This improves response mean delay as well as accuracy of the SPS.

3.9 Evaluation Technique

This research uses simulation to evaluate the new EWMA buffering SPS. Previously validated data is used to compare results and determine if the new SPS works correctly based on past performance and if it is a viable solution for the future of the utility intranet.

The simulation setup used will conform to the test matrix presented in Table 3. Each scenario is performed ten times with varying seed. The simulation will begin at normal power system operation. At 0.0 seconds, the power system is subjected to a line fault from bus 1 to bus 25. The line fault initiated at 0.0 seconds last until 0.15 seconds. At 0.15 seconds, the system undergoes a branch trip from bus 1 to 25. The simulation is run for 50 seconds to ensure power system stabilization. This condition is set for all scenarios on the test matrix. Mean delay and accuracy data is collected and compared to previous validated results.

Table 3. Test Matrix Performed Per Repetition

Background Traffic Load	Reservation Type	SPS Bufer
None	None	Without EWMA
None	Router Reservation	With EWMA
Light	None	Without EWMA
Light	Router Reservation	With EWMA
Medium	None	Without EWMA
Medium	Router Reservation	With EWMA
Heavy	None	Without EWMA
Heavy	Router Reservation	With EWMA

3.10 Simulation Environment

Most of the simulation environment was chosen to strictly followed those proposed by Roberts in [3]. A brief summary of parameter setting and basic assumptions follows.

Reservation Type

The test matrix is broken into categories depending if it used router reservation scheme or not. Each background traffic level is simulated with no active router reservations and with active router reservations through the network. When router reservations are used, NS2's internal routing algorithm is modified to allow for selective packet destination based on flow ID. Protection traffic is given a high priority and run over reserved channel space while background traffic was given a low priority and ran over unreserved space. When no reservations are used the simulation used NS2's default internal algorithm and all traffic has the same priority.

Reservations made through routers are created based on their flow-ID. All reservations are 2 MB in size and go from bus 1 (where main SPS agent is located) to each of the 50 generators and from bus 1 to the 5 buses were the loads to be shed during the simulations, if shedding is required. The reservations are repeated in the reverse direction so all flows are full duplex for a total of 110 reservations. When bandwidth is available for background traffic, the agent traffic doesn't actively use the reservation. When agent traffic is sent over its reservation and background traffic is present and the queue is full, it overrides the background traffic and enough background traffic is dropped to ensure room at the end of the queue for agent traffic. If there is already room in the queue, the agent traffic goes into the back of the queue. Background traffic will not be allowed further use of the reservation unless there is sufficient capacity to process all agent traffic in the queue.

Background Traffic

Based on Table 2 for low traffic loads, the background traffic consists of white sources only, medium traffic loads consist of light gray and white traffic sources, and heavy traffic loads will of dark gray along with light gray and white traffic sources.

3.11 Simulation Setup

3.11.1 Scenario 1 Simulation

In Scenario 1, 50 seconds of acquiring frequency data reported by the load and generator agents is collected. During each simulation run the α value of 55% and no router reservation scheme parameters is held constant while varying network background traffic. At the beginning of a simulation, a line fault is introduced at time equal to 0.0s. The simulation is run up until time equal to 0.15s when a line trip command is issue. Then, a generation rejection command is sent to generator 93 at time 0.18s. The simulation is run to collect data up to 50s to allow the system to reach steady state.

3.11.2 Scenario 2 Simulation

In Scenario 1, 50 seconds of acquiring frequency data is reported by the load and generator agents. During each simulation run the α value of 55% and router reservation scheme parameters is held constant while varying network background traffic. In the beginning of a simulation a line fault is introduced at time equal to 0s. The simulation is run up until time equal to 0.15s, when a line trip command is issue. Then, a generation rejection command sent to generator 93 at time 0.18 s. The simulation is run to collect data up to 50 s to allowed system to reach steady state.

3.11 Experimental Design

The overall experimental design for this study consists of two sub-experiments, each with a full-factorial design with the factors stated above. The first sub-experiment, which simulates Scenario 1, consists of 10 repetitions for each configuration, requiring a total of 60 simulation runs (scenario 1: $3 * 2 * 2 * 10 = 60$). The second sub-experiment, which simulates Scenario 2, consists of 10 repetitions for each configuration, requiring a total of 60 runs (scenario 2: $3 * 2 * 2 * 10 = 60$). Thus, the overall experiment will consist of 120 simulation runs. The number of repetitions is chosen to provide a narrow enough confidence interval while attempting to minimize the number of experiments necessary. Each of the repetitions for the same configuration uses a different seed for the random number generator which affects how the background traffic is generated.

3.12 Analysis and Interpretation of Results

The analysis of the data supports the goals of this research. Errors in the sampled data are assumed to be normally distributed and confidence intervals are used to compare the performance of the two SPS algorithms. If the confidence intervals do not overlap they are said to have a significant statistical difference for the measured performance metric. Otherwise, if the confidence intervals overlap, the architectures cannot be deemed statistically different and thus, one SPS cannot be said to perform better or worse than the other in terms of the measured performance metric.

To allocate the variation in the collected data, an Analysis of Variance (ANOVA) is performed on each metric. The ANOVA can be obtained by using the formula

$\bar{x} \pm z_{\alpha/2} \left(\frac{\sigma}{\sqrt{n}} \right)$, where \bar{x} is the sample mean, $z_{\alpha/2}$ is the z-value with an area of $\alpha/2$ to

its right and is obtained from lookup tables, σ is the population standard deviation and n is the sample size. For a 99% confidence interval $z_{\alpha/2}$ is 2.576. The ANOVA analysis shows if the variance is due to experimental error or real differences in the changing factors. In order for the results of the ANOVA to be valid several assumptions must hold. The assumptions of the ANOVA are: the errors are random, independent, normally distributed with a mean of zero, and have a common variance.

3.13 Summary

This chapter discusses the methodology used to evaluate the performance of EPOCHS system applying SPS algorithm with EWMA and varying router reservation. This research is evaluated via simulations performed using EPOCHS, PSS^{TME} and NS2 based on UDP protocols: *System frequency and minimum system frequency* are used to determine overall system steady state stability. A full-factorial experiment is performed on two different scenarios to evaluate the impact of SPS algorithms while background traffic varies.

IV. Results and Analysis

4.1 Introduction

This chapter presents and analyzes the simulation. First, the new SPS algorithm is tested and compared with previous results for validating the SPS algorithm and baseline establishment. Next, the results of each individual performance metric are presented. Finally, an overall analysis of the results is provided.

4.2 Architecture Model Validation

The purpose of this section is to validate the SPS algorithm evaluated in this study. This is accomplished by duplicating the experiments documented in [17] and [3] and comparing the results to the original findings.

In the original SPS experiments, a fault occurs on the 1–25 line at time 0. The fault is cleared and a trip command is sent to generator 93 at 0.15 s. Because the fault is cleared after the critical fault-clearing time, the system becomes transiently unstable, and one group of 17 generators loses synchronism with another group of 33 generators. The main SPS agent at bus 1 recognizes the situation and begins to communicate with other system agents to gather data values, including generators' connection status, active power outputs, and angular frequency. The main agent also issues a generation rejection order to the agent at bus 93. Bus 93 is chosen based on an offline simulation study [17].

Generation rejection keeps the system stable, but undergoes an unacceptable frequency decrease to 57.45 Hz, shown in Figure 17. Figure 18 shows an exact recreation of the scenario performed by [17] validating applied the SPS algorithm.

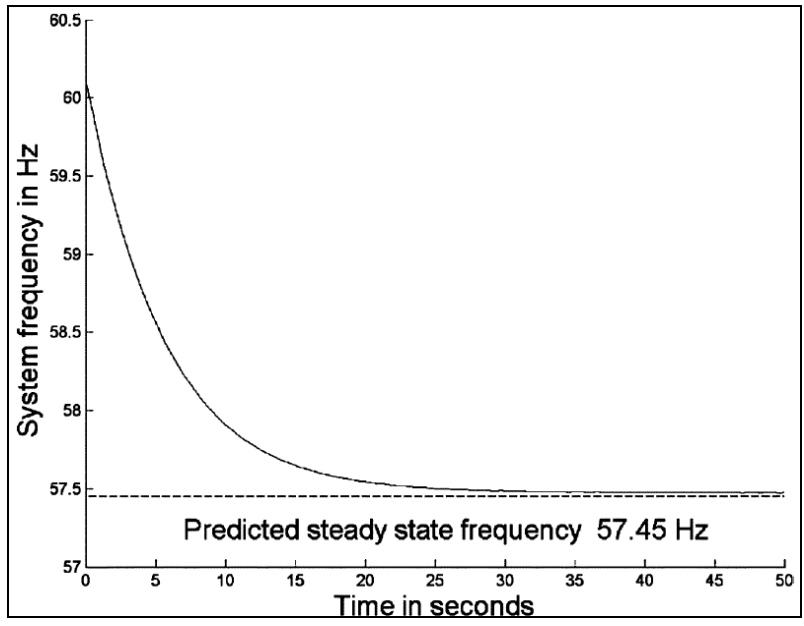

Figure 17. System Undergoes an Unacceptable Frequency Decrease [17]

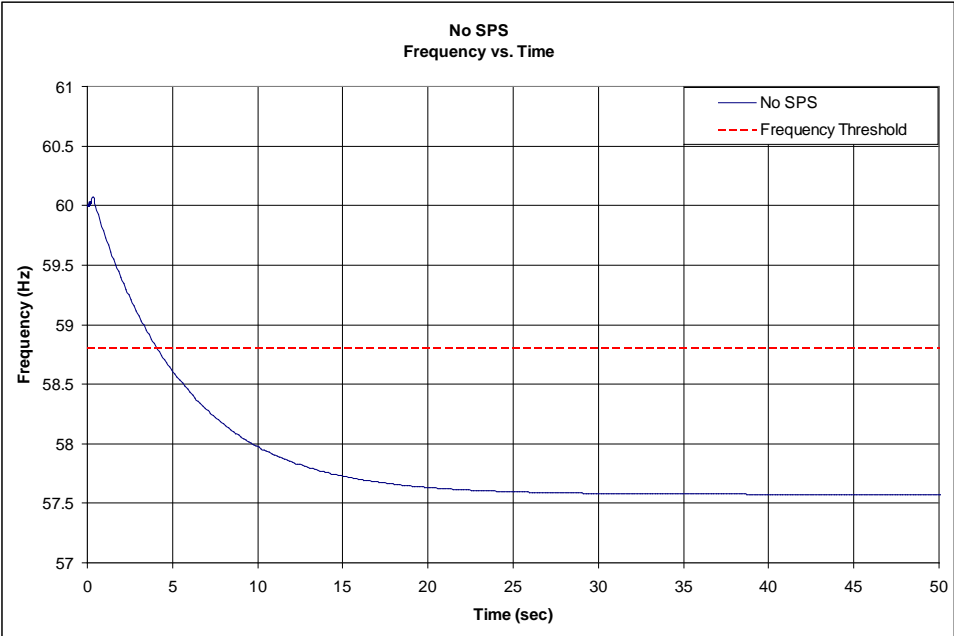

Figure 18. Validation of SPS Algorithm[17]

4.3 Results and Analysis of Performance Metrics

This section interprets and analyzes the relevant data collected from the simulations. The performances of the scenarios tested are analyzed in terms of each metric individually, followed by an overall performance analysis. Results from Scenario 1 are analyzed first followed by the results from Scenario 2. Several graphs for each metric are shown in the following sections. The confidence intervals shown on the plots are in accordance for a 99% confidence evaluation given the risk involved in power system applications. An alpha value/memory buffer of 55% is used for all cases utilizing EWMA algorithm. The alpha value was chosen by rigorous simulation, taking into account a 1% change for each iteration run of the test. It was assumed that proper operation of the memory buffer in the worst case scenario would imply successful memory buffer assignment to lower background traffic intensity scenarios. Overall simulation proves the assumption correct. All simulations are conducted in accordance with the baseline scenario [3].

4.3.1 Analysis of Scenario 1

This section analyzes the results from the Scenario 1 simulations. This scenario does not apply router reservation scheme while applying EWMA or Non EWMA algorithm and varying background traffic present on the network.

4.3.1.1 UDP without Router Reservation with Heavy Background Traffic

The analysis of *heavy background traffic* highlights the importance of using EWMA within the SPS algorithm in order to ensure overall system stability. The key element to observe is the minimum frequency value obtained while utilizing EWMA. Figure 19 shows the system frequency response under heavy background traffic without router reservation using UDP protocols.

As expected, the use of EWMA within the SPS algorithm yields a higher minimum frequency and faster system stabilization. The average minimum frequency observed in simulation for the SPS using EWMA is 59.08 Hz. Using a 99% confidence interval analysis (see Appendix – A1) shows that the minimum mean is 59.0 Hz with an upper confidence interval of 59.11 Hz and a lower confidence interval of 58.86 Hz. This is compared to the SPS not using EWMA which produce a simulation average minimum of 58.36 Hz. Performing a 99% confidence analysis produces an unsatisfactory minimum mean frequency of 58.35 Hz with an upper confidence interval of 58.61 Hz and a lower confidence interval of 58.09 Hz. Performing an ANOVA test indicates that there is convincing evidence that the SPS using the EWMA algorithm yields a higher minimum frequency. Since this is a randomized experiment, causality can be inferred thus, indicating that using the EWMA algorithm was the cause for the system stability improvement. However, this study relies on the IEEE 145 Bus 50 Generator test case not randomly selected; therefore, this cannot be inferred to other population.

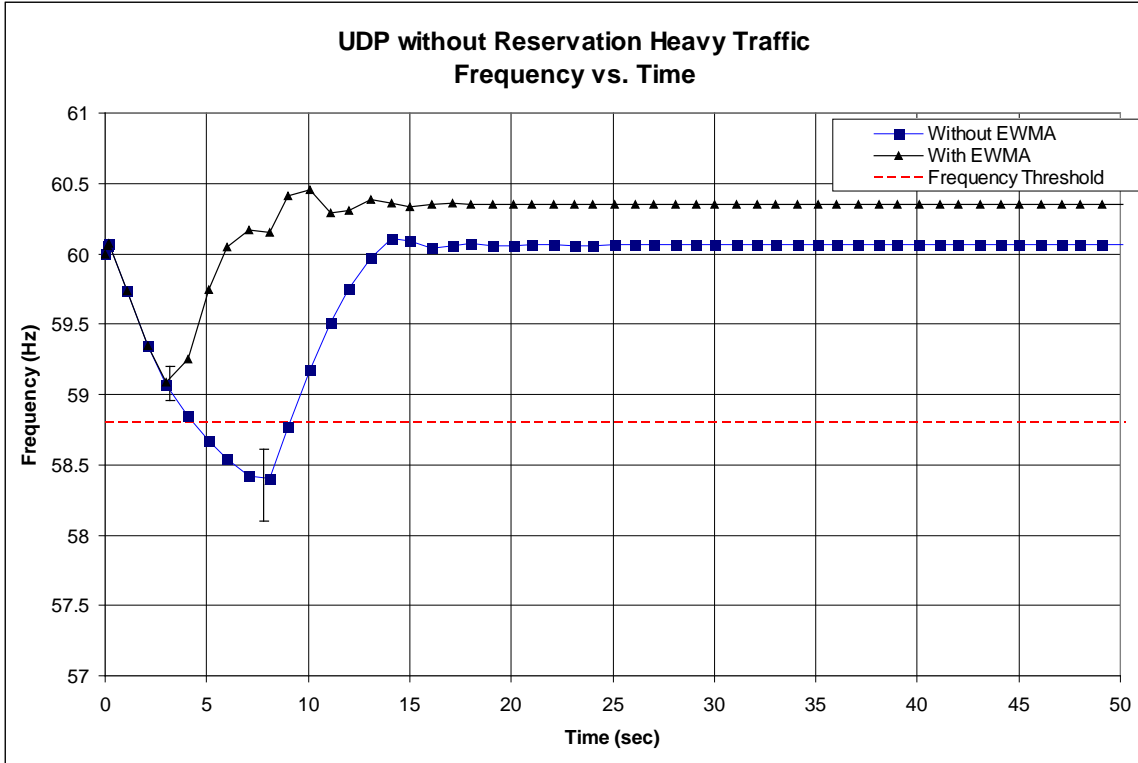

Figure 19. System Frequency Response under Heavy Traffic without Router Reservation

4.3.1.2 UDP without Router Reservation with Medium Background Traffic

The analysis of *medium background traffic* (Figure 20) also highlights the importance of using EWMA within the SPS algorithm in order to ensure overall system stability. Similarly as the previous section, the SPS using EWMA algorithm yielded a higher minimum frequency. Again, the key element to observe is the minimum frequency value obtained while utilizing EWMA algorithm. The average minimum observed in simulation for the SPS using EWMA is 59.4 Hz. Using a 99% confidence interval analysis (Appendix – A2) shows that the minimum mean using the EWMA algorithm is 59.24 Hz with an upper confidence interval of 59.41 Hz and a lower confidence interval of 59.08 Hz. This is compared to the SPS not using EWMA which produce a simulation average minimum of 58.26 Hz. Performing a 99% confidence analysis produced an

unsatisfactory minimum mean frequency of 58.24 Hz with an upper confidence interval of 58.31 Hz and a lower confidence interval of 58.16 Hz. Performing an ANOVA test indicates that there is convincing evidence of a difference between the SPS using the EWMA algorithm yields a higher minimum frequency. Since this is a randomized experiment, causality can be inferred thus, indicating that the EWMA algorithm was the cause for the system stability improvement. However, this study relies on the IEEE 145 Bus 50 Generator test case not randomly selected; therefore inferences cannot be made to other populations.

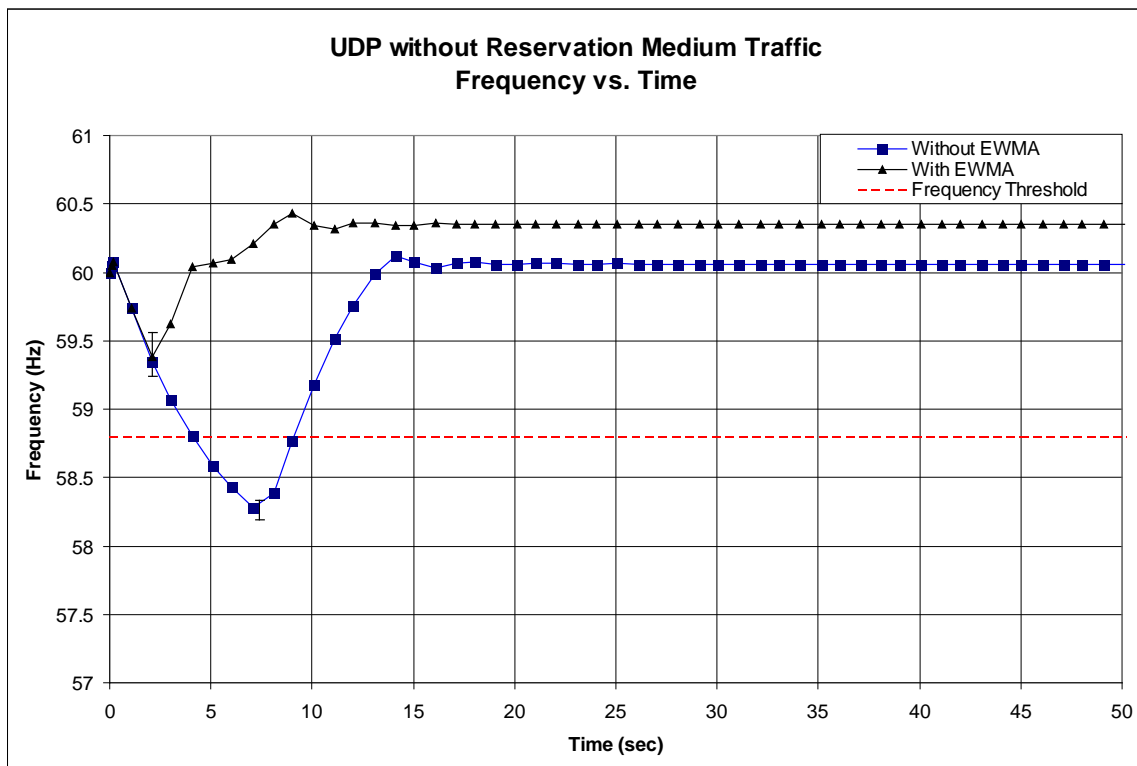

Figure 20. System Frequency Response under Medium Traffic without Router Reservation

4.3.1.3 UDP without Router Reservation with Light Background Traffic

The analysis of *light background traffic* (Figure 21) produced expected results. Since light background traffic is present on the network, the system is able to stabilize appropriately without reaching the frequency threshold on any case. The mean minimum observed while utilizing the SPS with EWMA algorithm in this simulation is 59.70 Hz. Performing a 99% confidence interval analysis (Appendix – A3) shows that the minimum mean frequency using the EWMA algorithm is 59.70 Hz with an upper confidence interval of 59.72 Hz and a lower confidence interval of 59.69 Hz. This is compared to the SPS not using EWMA which produces a simulation mean minimum of 59.70 Hz. Performing a 99% confidence analysis produced a minimum mean frequency of 59.70 Hz with an upper confidence interval of 59.72 Hz and a lower confidence interval of 59.68 Hz. Performing an ANOVA test indicates that there is convincing evidence that there is a difference between the SPS using the EWMA algorithm and the non EWMA, which explains the faster stability time with the EWMA algorithm versus non EWMA. However, applying a 99% confidence interval indicates that both are statistically the same regarding the mean minimum frequency value. Since this is a randomized experiment, causality can be inferred thus, indicating that the EWMA algorithm was the cause for the system stability improvement. However, this study relies on the IEEE 145 Bus 50 Generator test case not randomly selected; therefore this cannot be inferred to other population.

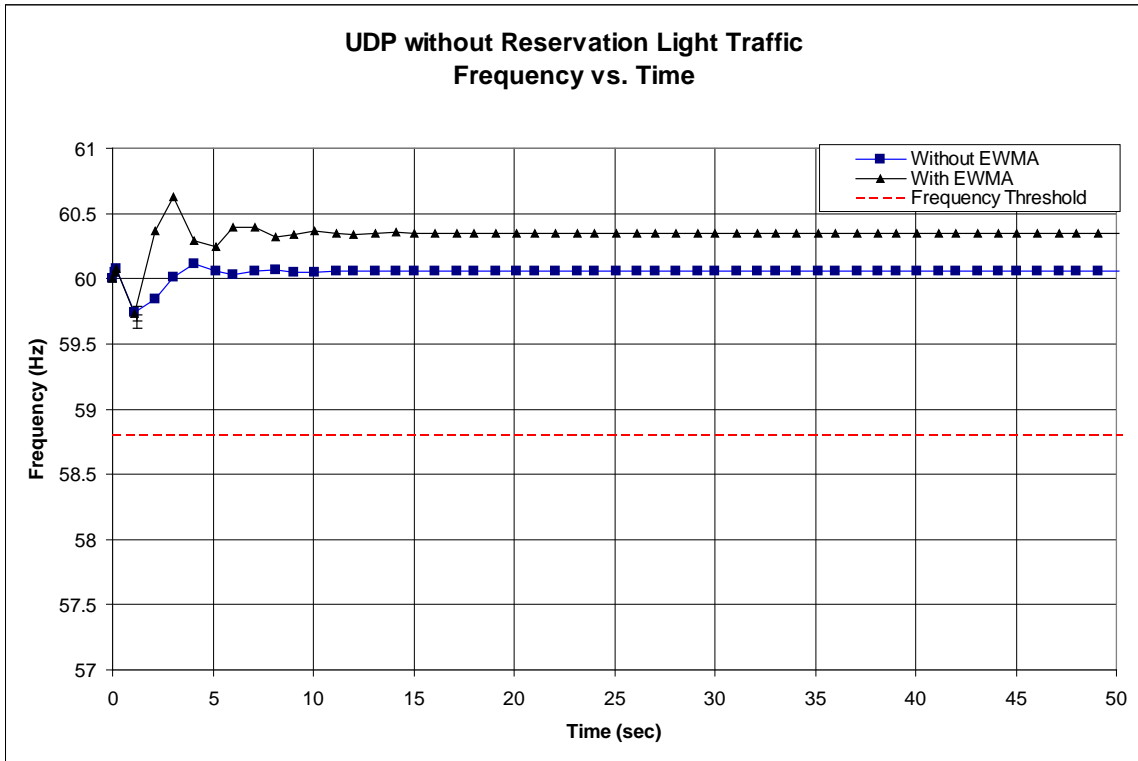

Figure 21. System Frequency Response under Light Traffic without Router Reservation

4.3.2 Analysis of Scenario 2

This section analyzes the results from the Scenario 2 simulations. This scenario applies a router reservation scheme while applying EWMA or Non EWMA algorithm and varying background traffic present on the network.

4.3.2.1 UDP with Router Reservation with Heavy Background Traffic

The analysis of *heavy background traffic* (Figure 22) with router reservation produced expected results. Since router reservation scheme is applied, the system stabilized appropriately without reaching the frequency threshold in any point. The average minimum frequency observed while utilizing EWMA algorithm in simulation is

59.35 Hz. Performing a 99% confidence interval analysis (Appendix – A4) shows that the minimum mean using EWMA algorithm is 59.29 Hz with an upper confidence interval of 59.38 Hz and a lower confidence interval of 59.20 Hz. This is compared to the SPS not using EWMA which produces a simulation mean minimum of 59.70 Hz. Performing 99% confidence analysis produced a minimum mean frequency of 59.33 Hz with an upper confidence interval of 59.48 Hz and a lower confidence interval of 59.18 Hz. Performing an ANOVA test indicates that there is convincing evidence that there is a difference between the SPS using the EWMA algorithm and the non EWMA. However, applying the confidence interval indicates (Appendix – A4) that both are statistically the same regarding the minimum frequency value. Since this is a randomized experiment, causality can be inferred thus, indicating that the EWMA algorithm was the cause for the system stability improvement. However, this study relies on the IEEE 145 Bus 50 Generator test case not randomly selected; therefore this cannot be inferred to a higher population.

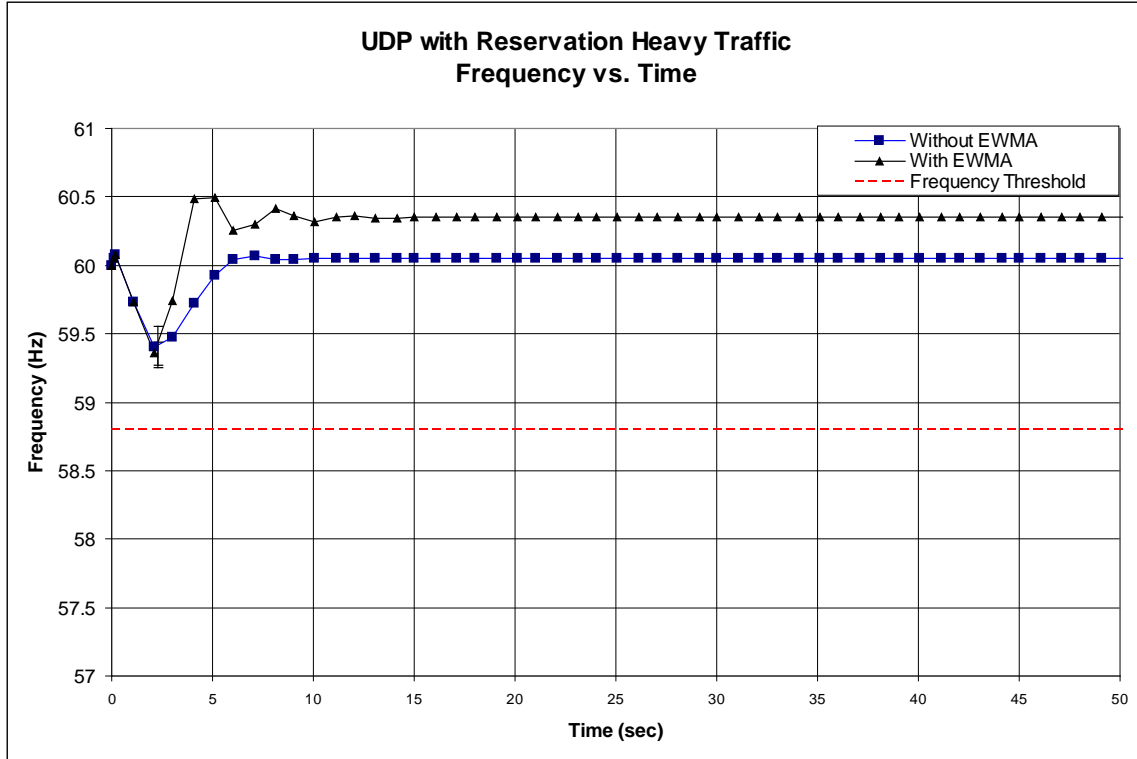

Figure 22. System Frequency Response under Heavy Traffic with Router Reservation

4.3.2.2 UDP with Router Reservation with Medium Background Traffic

The analysis of *medium background traffic* (Figure 23) with router reservation produced expected results. Router reservation scheme is applied and the system stabilizes appropriately without reaching the frequency threshold in any point. The average minimum observed while utilizing EWMA algorithm in simulation is 59.35 Hz. Performing a 99% confidence interval analysis (Appendix – A5) shows that the minimum mean using EWMA algorithm is 59.29 Hz with an upper confidence interval of 59.37 Hz and a lower confidence interval of 59.21 Hz. This is compared to the SPS not using EWMA which produces a simulation mean minimum of 59.35 Hz. Performing 99% confidence analysis produced a minimum mean frequency of 59.30 Hz with an upper confidence interval of 59.47 Hz and a lower confidence interval of 59.14 Hz. Performing

an ANOVA test indicates that there is convincing evidence that there is a difference between the SPS using the EWMA algorithm and the non EWMA. However, applying the confidence interval indicates (Appendix – A5) that both are statistically the same regarding the minimum frequency value. Since this is a randomized experiment, causality can be inferred, thus, indicating that the EWMA algorithm was the cause for the system stability improvement. However, this study relies on the IEEE 145 Bus 50 Generator test case not randomly selected; therefore this cannot be inferred to other populations.

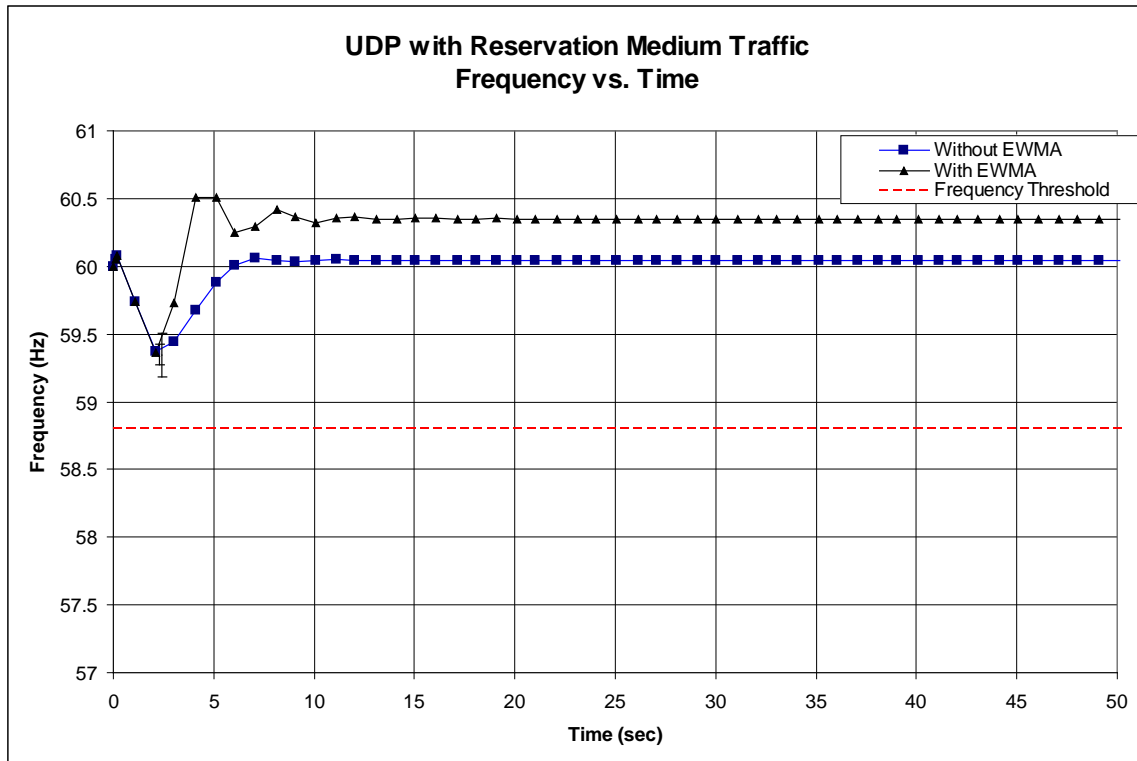

Figure 23. System Frequency Response under Medium Traffic with Router Reservation

4.3.1.3 UDP with Router Reservation with Light Background Traffic

The analysis of *light background traffic* (Figure 24) with router reservation produced expected results. Router reservation scheme is applied and the system

stabilizes appropriately without reaching the frequency threshold in any point. The average minimum observed while utilizing EWMA algorithm in simulation is 59.75 Hz. Performing a 99% confidence interval analysis (Appendix – A6) shows that the minimum mean using EWMA algorithm is 59.70 Hz with an upper confidence interval of 59.78 Hz and a lower confidence interval of 59.63 Hz. This is compared to the SPS not using EWMA which produces a simulation mean minimum of 59.66 Hz. Performing 99% confidence analysis produced a minimum mean frequency of 59.64 Hz with an upper confidence interval of 59.71 Hz and a lower confidence interval of 59.57 Hz. Performing an ANOVA test indicates that there is convincing evidence that there is a difference between the SPS using the EWMA algorithm and the non EWMA. However, applying the confidence interval indicates (Appendix – A6) that both are statistically the same regarding the minimum frequency value. Since this is a randomized experiment, causality can be inferred thus, indicating that the EWMA algorithm was the cause for the system stability improvement. However, this study relies on the IEEE 145 Bus 50 Generator test case not randomly selected; therefore results cannot be inferred to other populations.

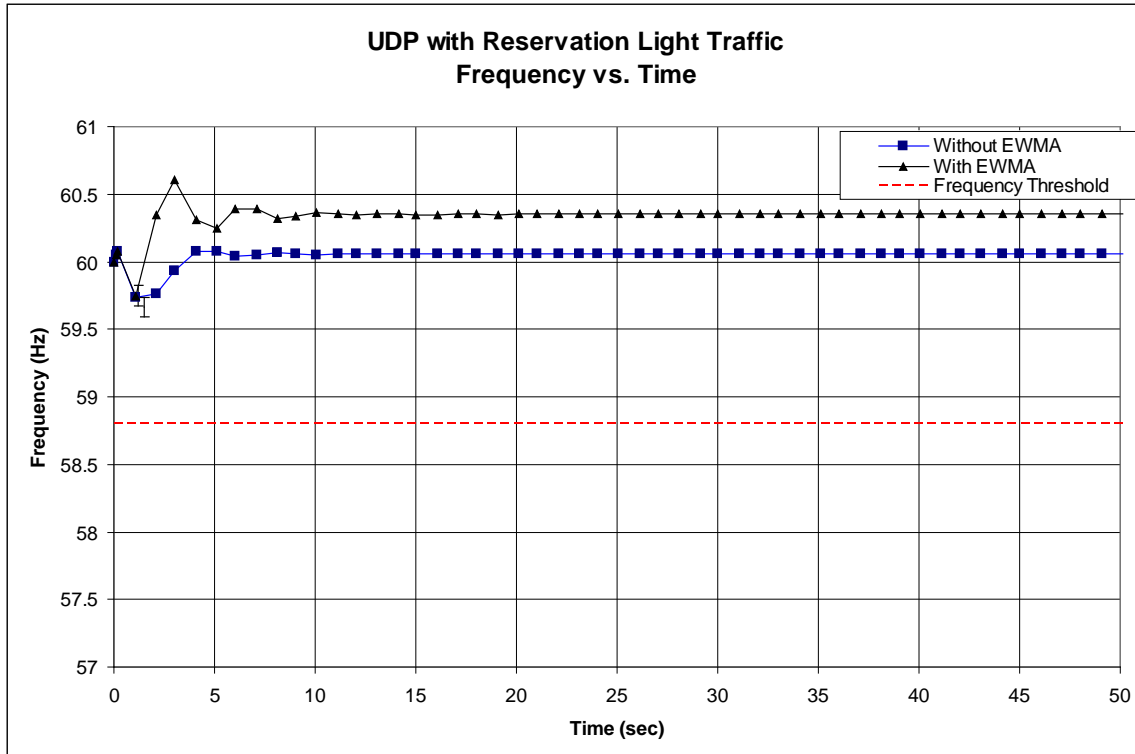

Figure 24. System Frequency Response under Light Traffic with Router Reservation

4.3 Overall Analysis

Several conclusions can be drawn from the simulations conducted. Most importantly, the statistical analysis of the data confirms the hypothesis. The SPS with EWMA algorithm provides statistically significant performance gains over the previously used SPS algorithm. By the agents reporting the exponential weighted moving average of the data values provides a faster response to a catastrophic branch trip. Also, using the SPS algorithm with EWMA guarantees a minimum frequency value above the frequency threshold independent of network background traffic.

Using 60.0 Hz as the normal steady state frequency operation of the power system, a difference squared error can be calculated for both algorithms. Appendix A-7 shows the error squared calculation dependent if EWMA was used in the simulation. Appendix A-7 shows that with a 99% confidence interval the EWMA algorithm thus increased the mean error from 35.77 to 42.80. The error being introduced by EWMA is acceptable [29] since it is less than the frequency threshold tolerated by a power system. However, the value added in using EWMA algorithm is that the variability of the frequency in power grid after the disturbance has occurred is dramatically reduced. Thus providing for an overall better stable system

Other conclusions that can be drawn from the overall analysis of the simulations are the effects of using the SPS with EWMA algorithm while router reservation scheme is implemented. The data provides that using EWMA does not provide a higher minimum mean frequency. This result is because while under router reservation the system always provide with a satisfactory minimum frequency above the frequency threshold.

4.4 Summary

This chapter presented and analyzed the data collected from the simulations of the EPOCHS system using the SPS with and without EWMA. First, the validation of the SPS with EWMA was presented. Then, the performance of each SPS algorithm was statistically analyzed for both scenarios in terms of network background traffic present. Finally, an overall analysis and discussion of the results was provided.

V. Conclusion

5.1 Introduction

This chapter summarizes the overall conclusions of the research. First the conclusions captured from the experimental results are presented. Next, the significance of this research is presented. Finally recommendations for possible areas of future work are described.

5.2 Conclusions of Research

This research determines that the EWMA can successfully be applied to the SPS in EPOCHS increasing its reliability under all simulated network background conditions. Using EWMA to create a buffer provides the capability to retain some information of the previous data, while still retaining information of current state of the system. However, it needs to be pointed out that by using EWMA for disturbance size calculation introduces some error and thus steady state after disturbance is not comparable with the case not using EWMA. Regardless of the error introduced, in all cases the error is considered to be acceptable and is within threshold value to be considered normal operation state of a power grid.

The largest performance gains are seen when applying SPS with EWMA while heavy background traffic and no router reservation is present. In this scenario, the SPS with EWMA improves the minimum frequency from 58.35HZ to 59.08HZ while the system is in transient or anomalous state and stabilizes to normal operating state of 60.35Hz. This effect is important to point out, since, it demonstrates that the utility intranet could be establish using standard UDP protocols to transmit while avoiding

expensive router reservation schemes deployment. In all cases, statistical analysis of the injection of the EWMA to the SPS metrics found that it provided for a quick reaction to system disturbances while minimizing errors in steady state stabilization.

5.3 Significance of Research

This research is a continuing effort to provide a more robust EPOCHS system to ensure power systems stability in potentially catastrophic scenarios. By applying the SPS with EWMA, the EPOCHS system provides a practical solution to react to power system faults and prevent catastrophic cascading power system failures while using a well known transport protocol, UDP. Through careful research and simulation, this study shows that the SPS with EWMA algorithm is a viable solution of ensuring the minimum frequency of 58.8Hz threshold are met. This research also puts the EPOCHS system under more tests and scenarios, further validating its potential as an efficient and perusable implementation of a power grid intranet backup system.

5.4 Recommendations for Future Research

This research provides a viable algorithm that could be applied regardless of network background traffic. However, the use of a static alpha value provides for an SPS EWMA case that may not be optimum for the background traffic present.

One recommendation for future work is to implement the SPS with EWMA algorithm with the optimum alpha value dependent background traffic conditions. In order to accomplish this goal, a traffic sensing algorithm will need to be developed in order to detect the traffic present in the network. Also, the optimum values of alpha will need to be calculated to be applied dependant on background traffic scenario. A

challenge that the traffic sensing might present is that it could potentially affect the reaction time for the SPS causing potential system instability.

Finally, the EPOCHS system could be easily applied to existing hardware simulator to collect real measurement.

5.5 Summary

This chapter presented the conclusions of this research. The significance of the research was discussed as well as several recommendations for future research.

Appendix A. 99% Confidence Interval Plots of the System Frequency

A.1 99% Confidence Interval for Heavy Traffic without Router Reservation

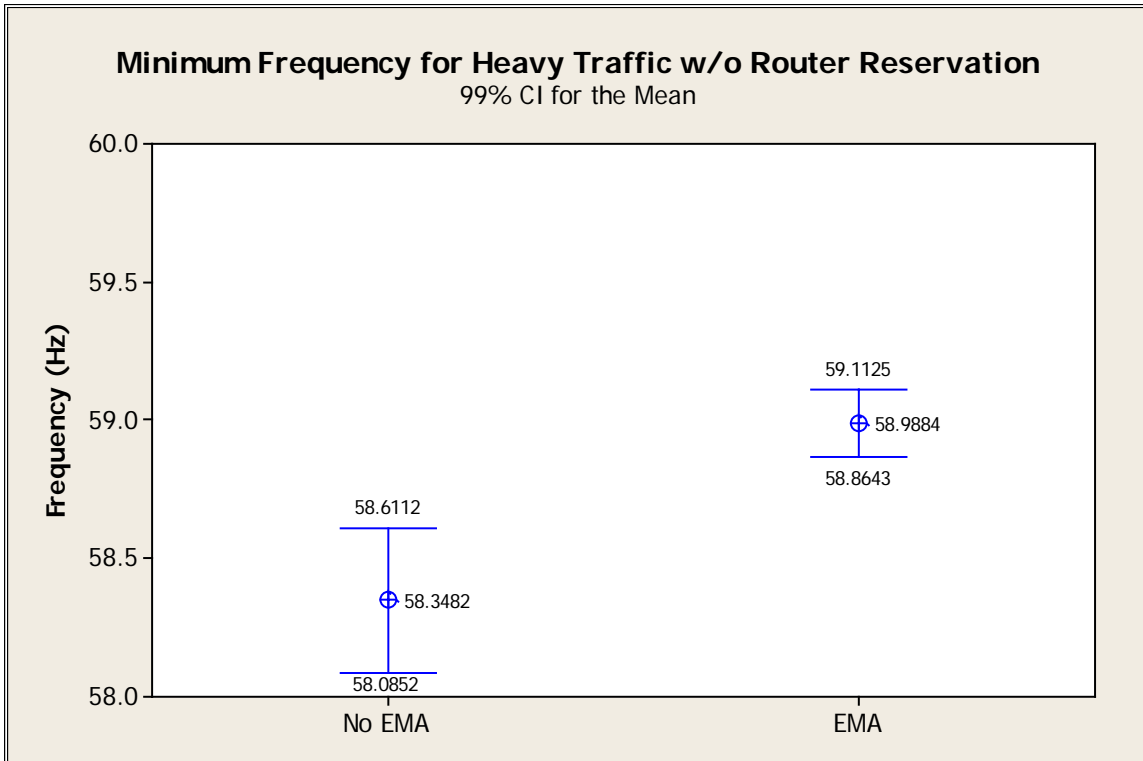
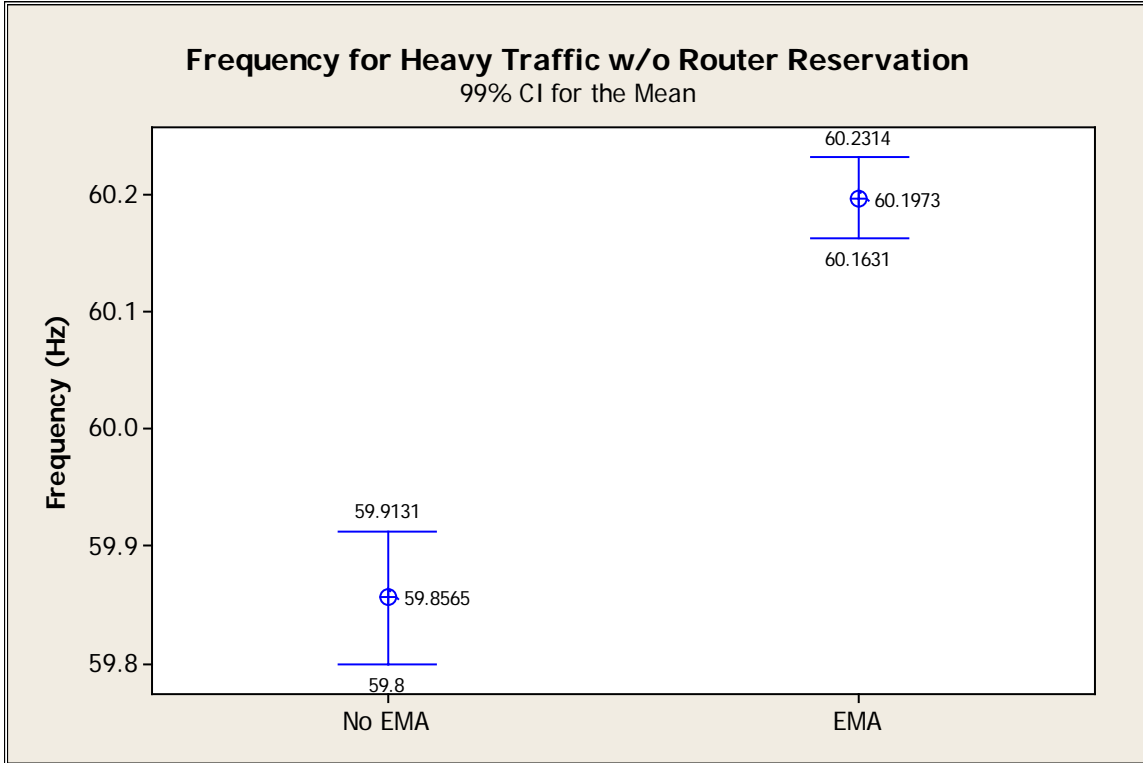

A.2 99% Confidence Interval for Medium Traffic without Router Reservation

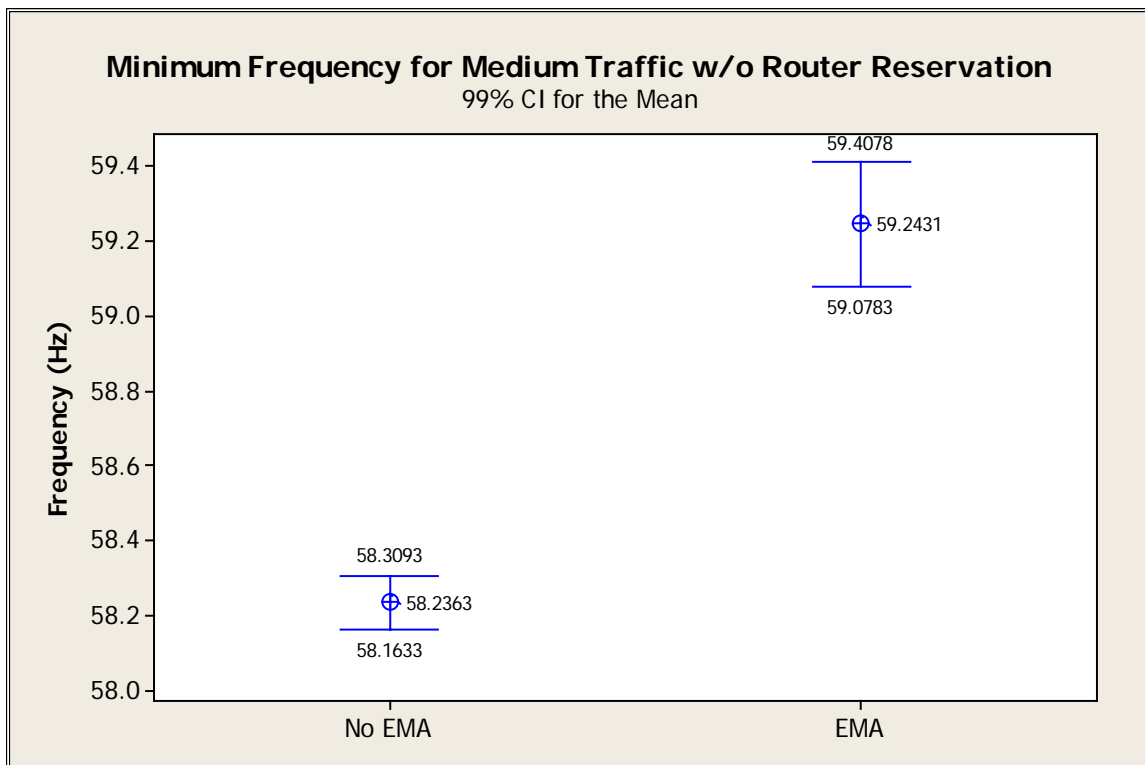
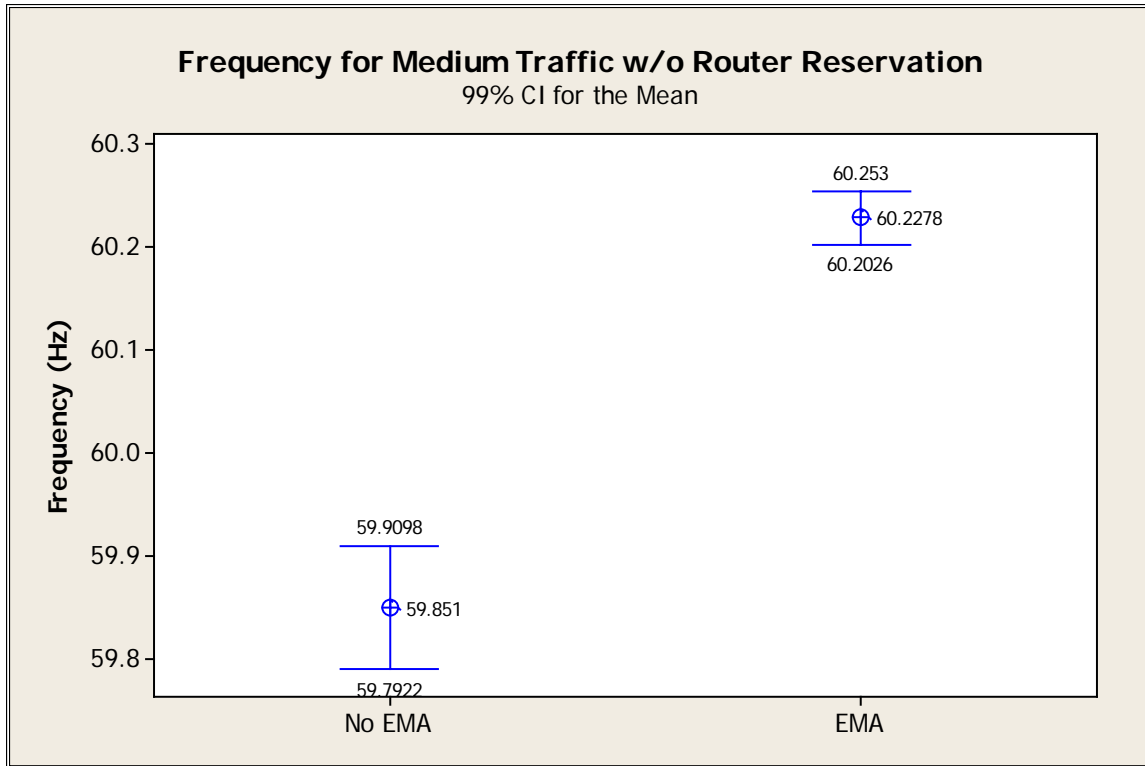

A.3 99% Confidence Interval for Light Traffic without Router Reservation

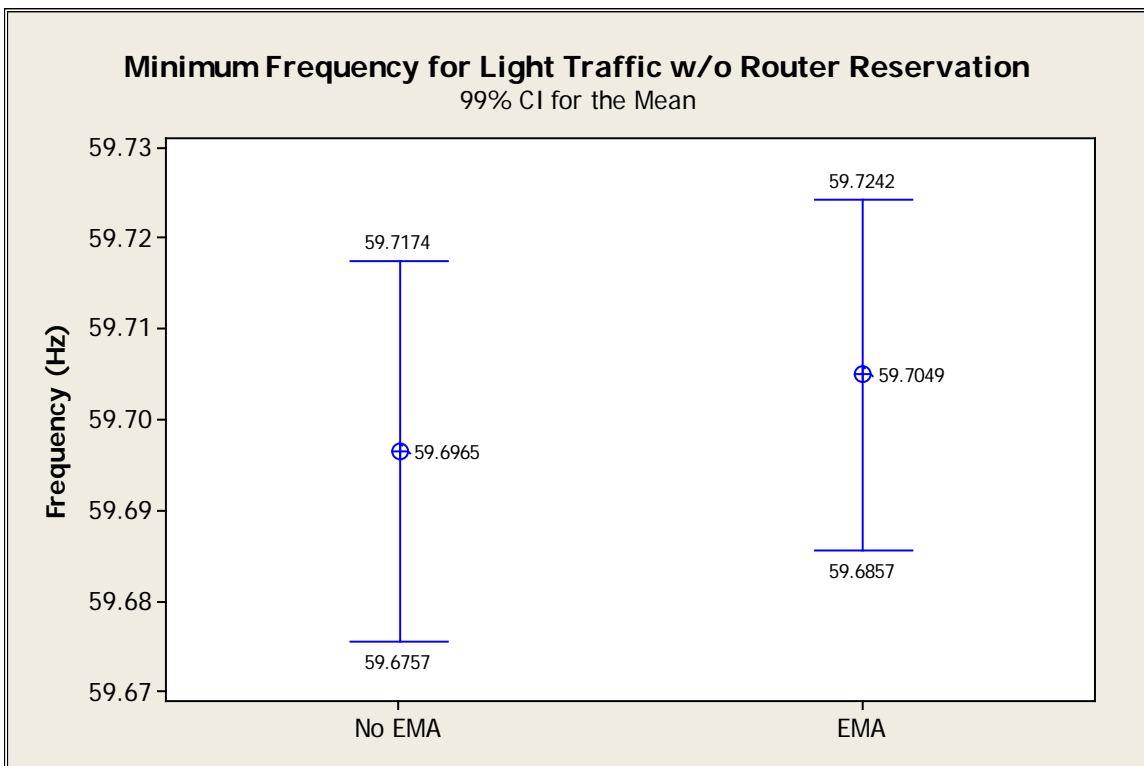
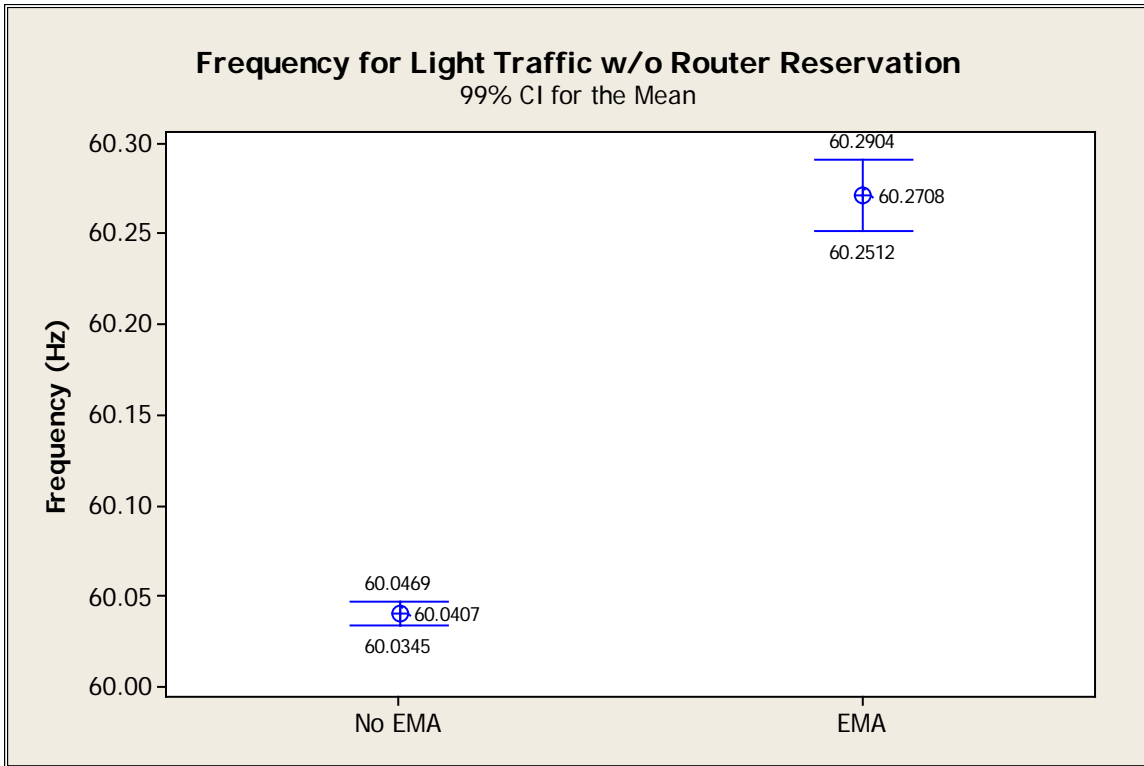

A.4 99% Confidence Interval for Heavy Traffic without Router Reservation

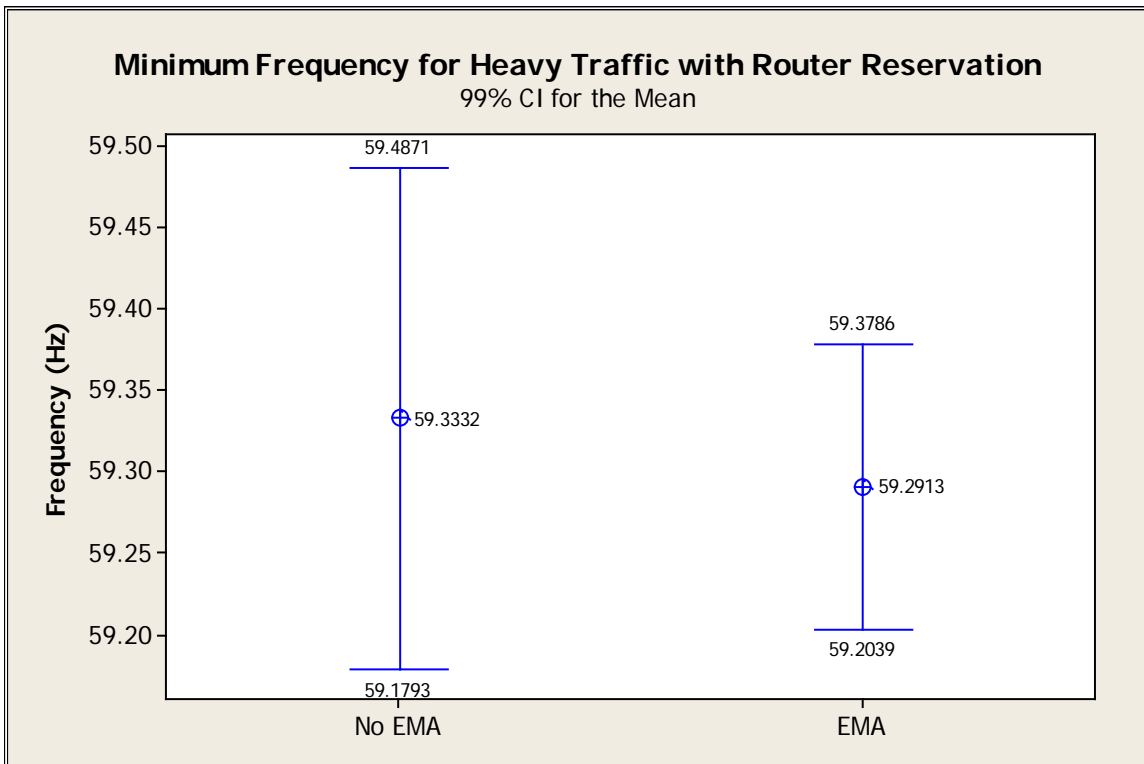
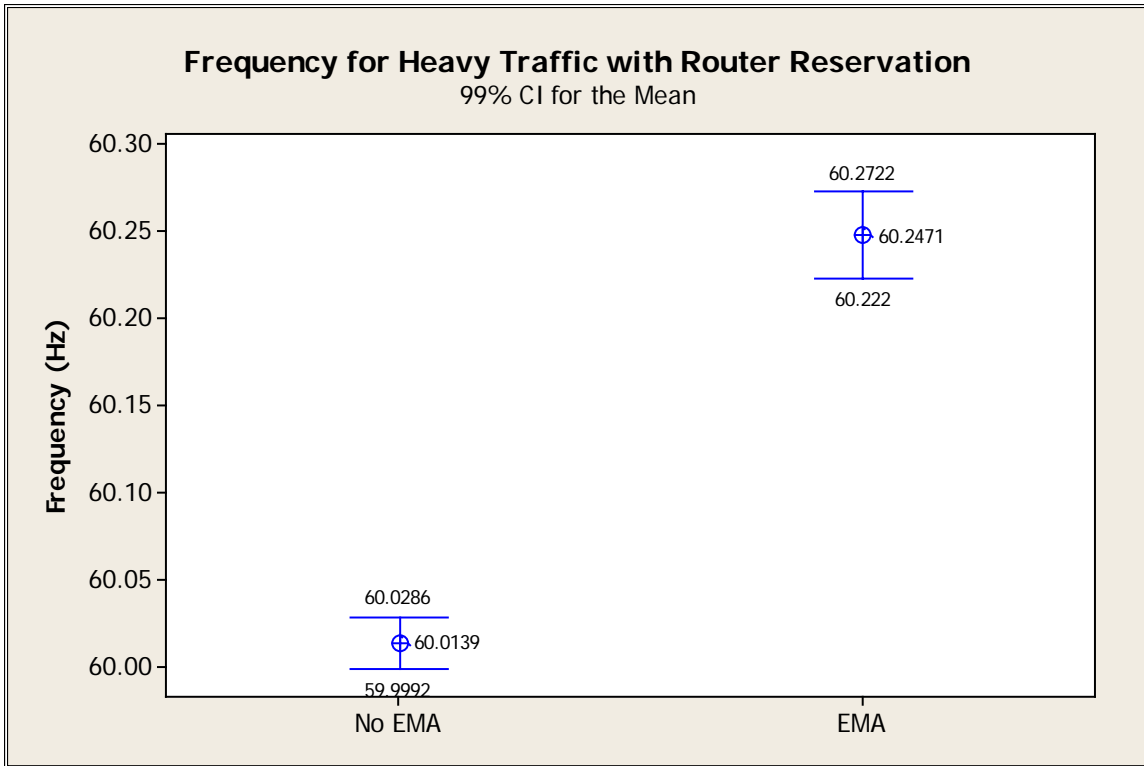

A.5 99% Confidence Interval for Medium Traffic without Router Reservation

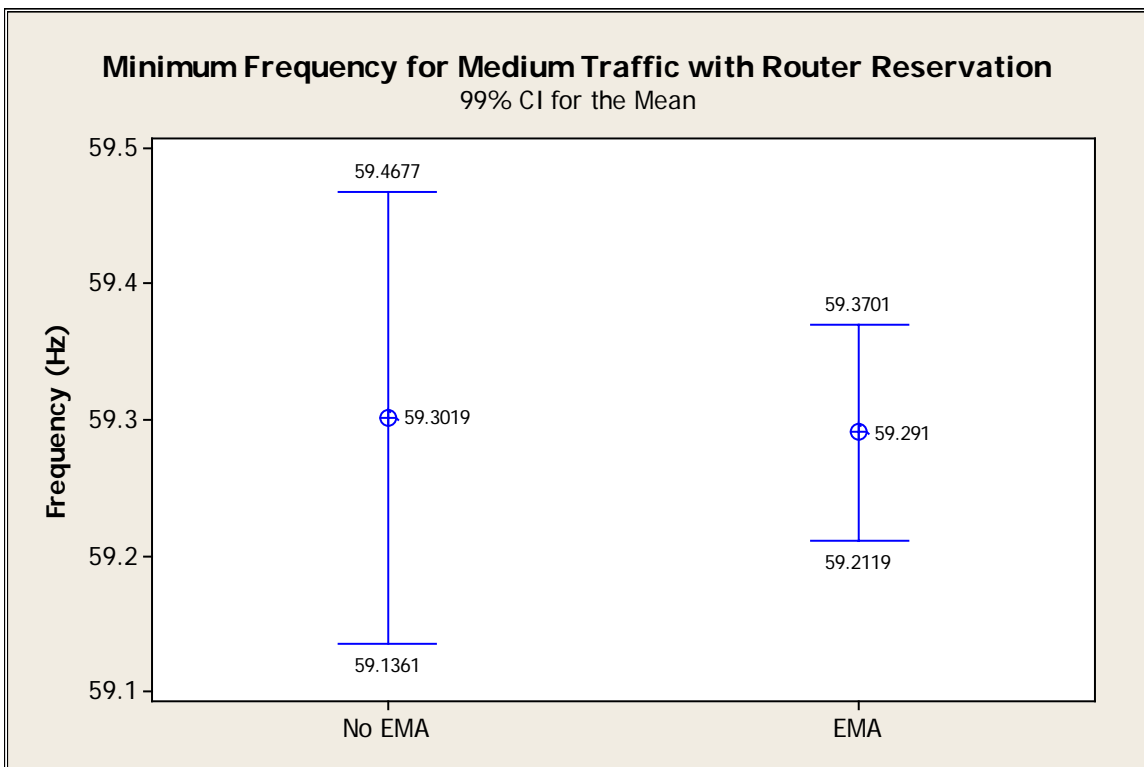
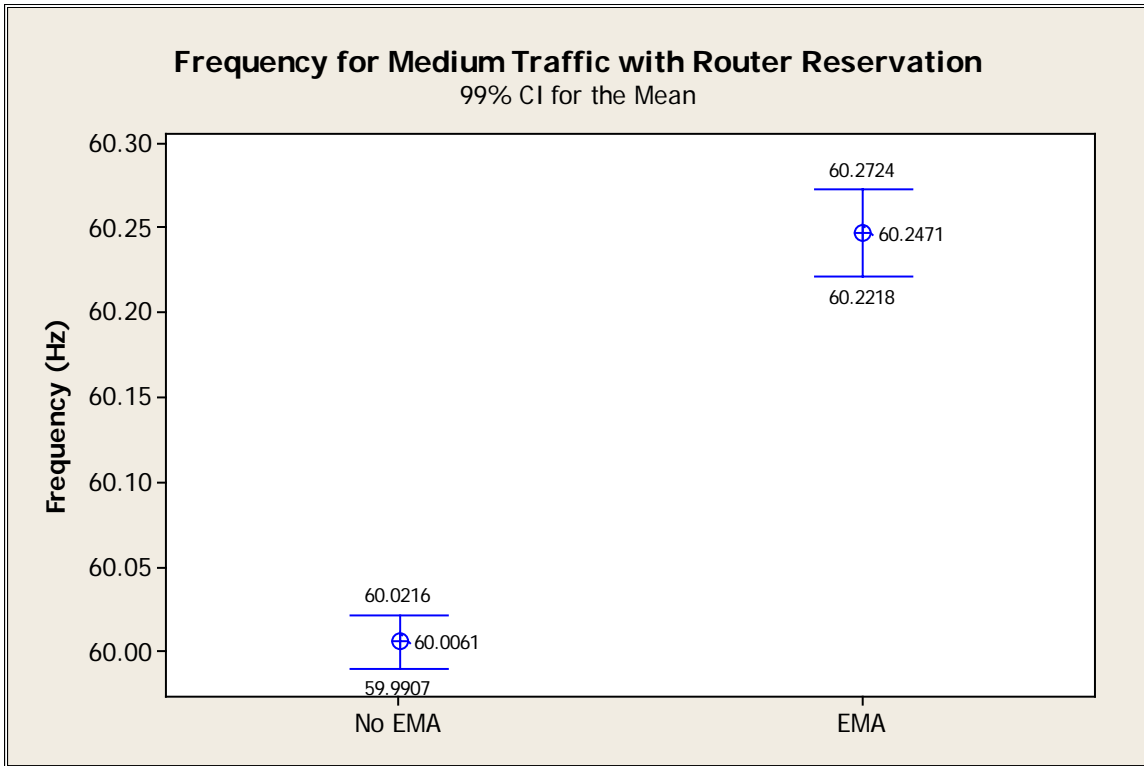

A.6 99% Confidence Interval for Light Traffic without Router Reservation

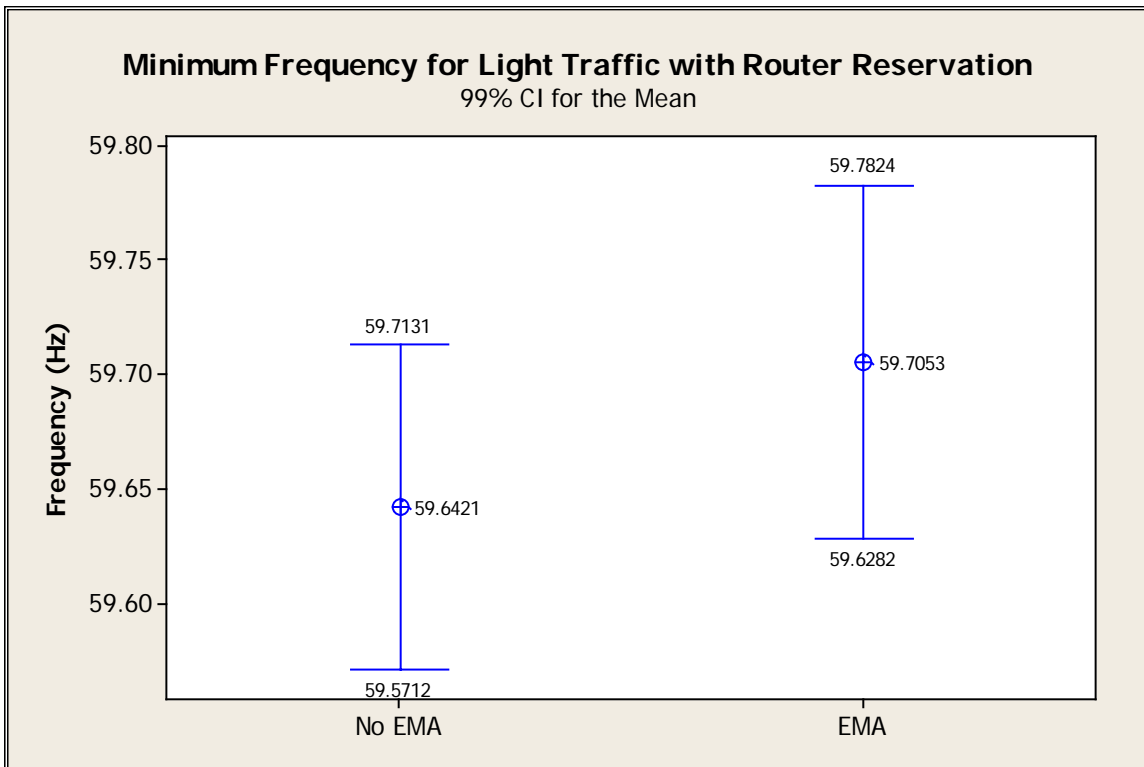
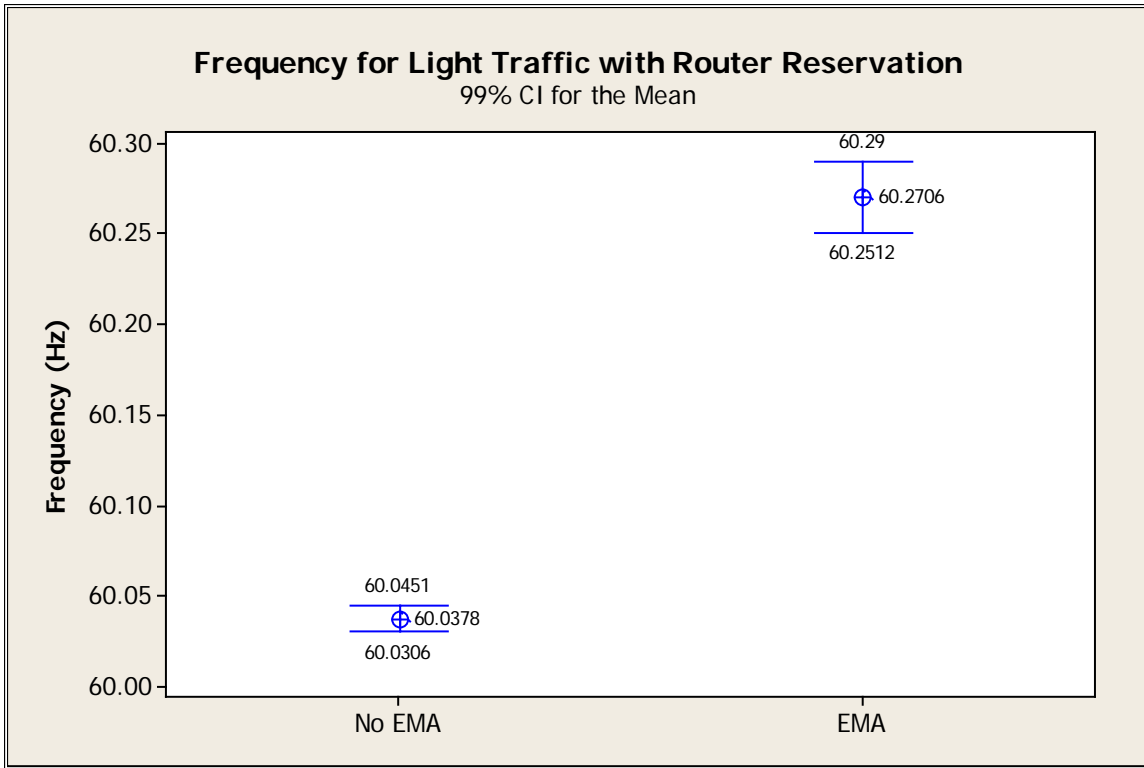

A.7 99% Error squared of Without SPS with EWMA and SPS With EWMA

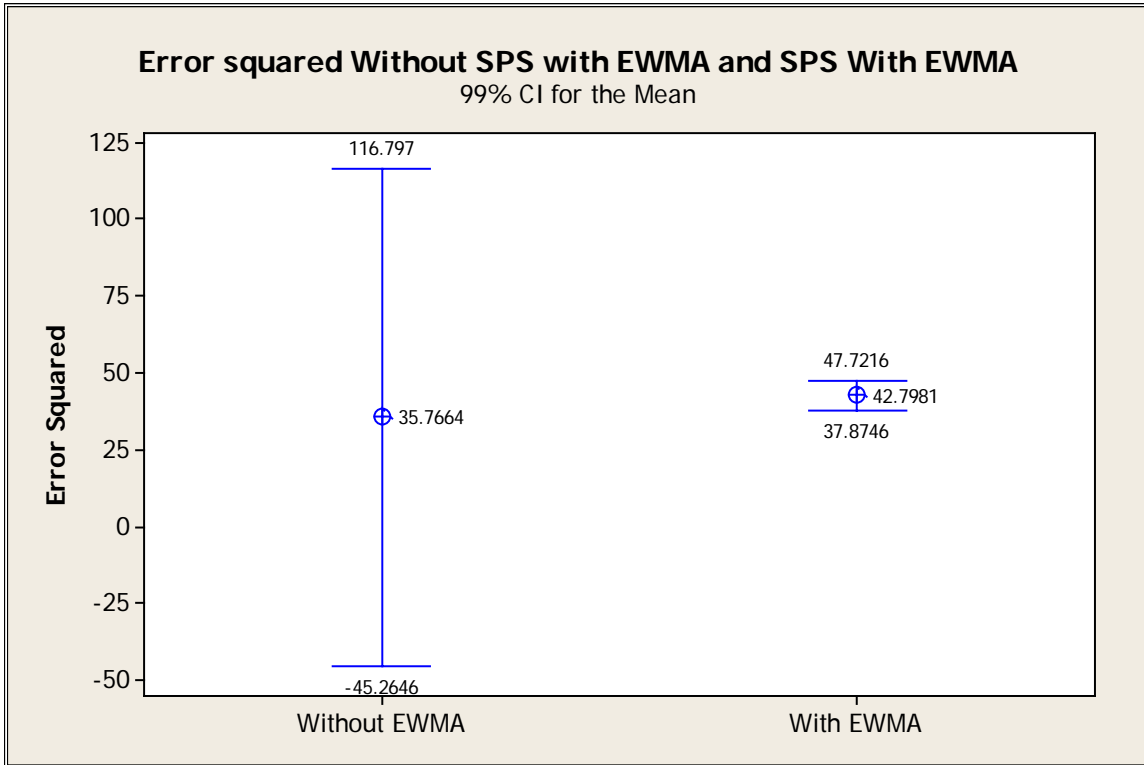

Appendix B. Procedures for Setting up and Running Simulations

Procedures

The following instructions will guide one through the steps required to run a simulation combining NS2, PSS/E, and EPOCHS simulators as described in this thesis. All software and programs should be installed on the 'C' partition of your computer.

1. Install the latest version of Cygwin from: <http://www.cygwin.com> . Note: Verify to install all options not only the default. There are some dependencies that required some libraries so to make sure just select them all.
2. Ensure all EPOCHS files are copied into the "c:/EPOCHS" folder.
3. The swap files required for simulation, are all located in "c:/ken/swap/" folder. These are files used by Cygwin and NS2 to communicate with each other. The AgentHQ in EPOCHS will manage the read/write process.
4. Install PSS/E with "60Hz" option selected.
5. Ensure you copy all PSSE files to "c:/Program Files/PTI/PSSE30/PSSLIB/" directory. Note: Make sure to have a backup of the default PSS/E "PSSLIB" folder in order to be able to run non EPOCHS scenario when desired.
6. Before and between simulations always ensure to run the "reset.bat" located in "c:/ken/swap" directory and run command from a DOS window. These bat files deletes variables from previous simulations and initializes them for new simulation. Note that if this step is not performed, the simulation will halt with a "bad handshaking" error.

7. Go to “C:\EPOCHS\background_scenario\config nscripts” and select the desired scenario. The scenarios are organized by Transport Protocol, then, by Reservation type and Background traffic. It should be self explanatory.
8. If you perform any changes to the files located in “C:\EPOCHS\ns-allinone-2.29\ns-2.29”, ns requires to be compile. In a Cygwin shell, go to the directory and run “make.exe”.
9. Copy “/EPOCHS/ns-allinone-2.29/ns-2.29/ns.exe” to “/ken/swap”.
10. Now you are ready to begin the simulation you just setup. Open a windows command window and two Cygwin command windows.
11. In a DOS command prompt run "/ken/swap/reset" to erase old files.
12. In one Cygwin window navigate to "/ken/swap/" and type in "gdb ns.exe". Then type "run nscript.tcl". This will start the NS2 simulator.
13. Go to "start/programs/PSSE 30/Dynamics_30 4000 Buses (pssds4)". This will start the PSS/E simulator.
14. To configure PSS/E for the simulation you need to perform the following steps:
 - a. Choose "LOFL" (Load Flow) from the buttons across the top of the window.
 - b. Choose "CASE" from the first row of buttons.
 - c. Browse to "/EPOCHS/PSSE Files/xiaoru_psse_code/dd50fl_exp2_detailc.sav" and click "Open".
 - d. Choose "Fact / Rtrn" from the buttons on the first row.
 - e. Choose "File / Input / Read dynamics model data (DYRE)".
 - f. Choose "Select..." next to "DYRE file", browse to "/EPOCHS/PSSE

- g. Files/xiaoru_psse_code/dd50dy_exp2_detail.dyr".
 - h. Choose "Select..." next to "CONEC file", choose "/EPOCHS/PSSE Files/xiaoru_psse_code/my_conec.flx".
 - i. Choose "Select..." next to "CONET file", choose "/EPOCHS/PSSE Files/xiaoru_psse_code/my_conet.flx". Click "OK".
 - j. Next choose "Edit / Dynamics Data (ALTR) / Solution parameters".
 - k. Set "Acceleration" and "Delta" and "Frequency filter" to ".002" and click "OK" and then "Exit".
 - l. Now choose some additional parameters to observe during the simulation. For this research I choose "CHAN / Angle" and enter nodes "67, 93, 99, 104,110, 111, 117, 124, 132" and click "OK" after entering each node. When finished click "No More". Choose "Exit". Note: This one of the ways to obtain data parameters from PSS/E. If you decide, you could modified the sps_background.cc file located in "C:\EPOCHS\ns-allinone-2.29\ns-2.29" to provide you with any data you required. Just remember that after you modify this file, NS2 will required to be compiled.
15. Click "MSTRT" to begin the PSS/E simulation engine.
 16. PSS/E will prompt for a "Channel Output File", click "Cancel".
 17. PSS/E will prompt for a "Snapshot file", click "Cancel".
 18. Choose "MRUN" and enter "0.000" in the "Run to" text box and click "OK".
 19. Click on "Disturbance / Line Fault / Select..." and choose from "Node 1" to "Node 25". Click "OK" and "OK" again.
 20. Choose "MRUN" again and enter "0.15" in the "Run to" text box and click "OK".

21. Click on "Disturbance / Trip Branch / Select..." and choose from "Node 1" to "Node 25". Click "OK" and "OK" again.
22. Choose "MRUN" again and enter "0.18" in the "Run to" text box and click "OK".
23. Choose "MRUN" again and enter desired time to run your simulation in order to reach steady state. For this thesis, the simulation was run up to "50.0" After the simulation completes you need to collect the output files to analyze. Locate and analyze the following files in the "/ken/swap/" directory:
 - a. three_values.txt
 - b. final_stats.txt
 - c. threshold_values.txt
 - d. center_spd_continuous.txt
 - e. center_spd_values.txt
 - f. gen_pmo.txt
 - g. pdelta_values.txt

Note: all of these "txt" files are the data that you are interested in analyzing.

These can be changed by adapting the sps_background.cc file to your convenience.

Random Number Generator Seed in TCL [3]

The following TCL instructions need to be added to the beginning of each "nscript.tcl" file to seed the random number generator with a different value to ensure the simulations don't produce the exact results with each execution:

```
#RANDOM NUMBER GENERATOR SEEDING  
  
# seed the default RNG  
  
global defaultRNG  
  
$defaultRNG seed 0  
  
# set the random number seed here  
  
ns-random defaultRNG
```

By setting the random number generator seed to '0' the system will set the seed based on the current time of the day and a counter.

Bibliography

- [1] "The Economic Cost of the Blackout: An issue paper on the Northeastern Blackout, August 14, 2003." vol. 2009: ICF Consulting, 2003.
- [2] J. V. Framingham, "Simulated Attack Shows Vulnerable US Power Infrastructure," in *Computer World*, 2007.
- [3] C. Gregory R. Roberts, USAF, "Evaluating Security and Quality of Service Considerations in Critical Infrastructure Communication Networks," in *ENG Wright Patterson Air Force Base: Air Force Institute of Technology*, 2005, p. 111.
- [4] C. E. Neil, "Entering the Seventh Decade of Electric Power, Some Highlights in the History of Electrical Development," *Edison Institute Bulletin*, p. pg.6, September 1942
- [5] E. I. Administration, "History of the U.S. Electric Power Industry, 1982-1991, Appendix A." vol. 2009: Energy Information Administration, 2001.
- [6] "Interconnections of the North American Electric Reliability Council in the Contiguous United States 1998."
- [7] "North American Electric Corporation Regions," Energy Information Administration.
- [8] "Federal Energy Regulatory Commission Order No. 888." vol. 2009: Federal Energy Regulatory Commission, 2006.
- [9] "Federal Energy Regulatory Commission Order No. 889." vol. 2009: Federal Energy Regulatory Commission 2006.
- [10] "State Status of Restructuring as February 2001 ": Energy Information Administration.
- [11] "Federal Energy Regulatory Commission Order No. 2000 Regional Transmission Organizations". vol. 2009: Federal Energy Regulatory Commission, 1999.
- [12] U. S.-C. P. S. O. T. Force, "Final Report on the August 14, 2003 Blackout in the United States and Canada: Causes and Recommendations April 2004," 2004.
- [13] W. A. Mittelstadt, P. E. Krause, R. E. Wilson, P. N. Overholt, D. J. Sobajic, J. F. Hauer, and D. T. Rzy, *The DOE Wide Area Measurement System (WAMS) Project: Demonstration of dynamic information technology for the future power system*, 1996.
- [14] "The Role of Synchronized Wide Area Measurements for Electric Power Grid Operations," in *Beyond SCADA: Networked Embedded Control for Cyber Physical Systems (HCSS-NEC4CPS)*: Pacific Northwest National Laboratory, U.S. Department of Energy, 2006.
- [15] P. M. Anderson, "Industry experience with special protection schemes," *Power Systems, IEEE Transactions on*, vol. 11, pp. 1166-1179, 1996.
- [16] M. Zima, "Special Protection Schemes in Electric Power Systems," Swiss Federal Institute of Technology Zurich, Zurich 2002.
- [17] K. Hopkinson, "EPOCHS: a platform for agent-based electric power and communication simulation built from commercial off-the-shelf components," in

- Power Systems, IEEE Transactions on.* vol. 21, W. Xiaoru, Ed., 2006, pp. 548-558.
- [18] "PSLF Manual." vol. 2009: General Electric, 2003.
- [19] "PSS/E - User Manual." vol. 2009: SIEMENS, 2004.
- [20] "PSCAD/EMTDC Manual Getting Sartetd." vol. 2009: Nayak Corporation, 1998.
- [21] "The Network Simulator - ns-2." vol. 2009, 1989.
- [22] R. Giovanini, "A primary and backup cooperative protection system based on wide area agents," in *Power Delivery, IEEE Transactions on.* vol. 21, K. Hopkinson, Ed., 2006, pp. 1222-1230.
- [23] "Communication networks and systems in substations ", 2nd Edition ed. vol. 2009: International Electrotechnical Commission, 2003.
- [24] J. F. Kurose and K. W. Ross, *Computer Networking A top-Down Approach.* Boston: Addison Wesley, 2008.
- [25] M. L. James, S. S. Michael, Robert V. Baxley, Jr., H. W. William, D. M. Hazem, W. F. Fedrick, J. H. Gerald, T. T. William, J. S. Hunter, F. M. John, and J. H. Thomas, "Exponentially weighted moving average control schemes: properties and enhancements." vol. 32: American Society for Quality Control and American Statistical Association, 1990, pp. 1-29.
- [26] S. Batra, C. Yul, and B. Yan, "Packet Buffer Management for a High-Speed Network Interface Card," in *Computer Communications and Networks, 2007. ICCCN 2007. Proceedings of 16th International Conference on,* 2007, pp. 191-196.
- [27] K. Ajey, M. Manoj, and A. K. Sarje, "A weighted cache replacement policy for location dependent data in mobile environments," in *Proceedings of the 2007 ACM symposium on Applied computing* Seoul, Korea: ACM, 2007.
- [28] I. Committee, "Transient stability test system for direct stability methods," *IEEE Trans. Power Syst.*, vol. Volume 7, pp. p. 37-43, Feb 1992 1992.
- [29] P. Kundur, *Power System Stability and Control:* MacGraw-Hill, 1994.

REPORT DOCUMENTATION PAGE

Form Approved
OMB No. 074-0188

The public reporting burden for this collection of information is estimated to average 1 hour per response, including the time for reviewing instructions, searching existing data sources, gathering and maintaining the data needed, and completing and reviewing the collection of information. Send comments regarding this burden estimate or any other aspect of the collection of information, including suggestions for reducing this burden to Department of Defense, Washington Headquarters Services, Directorate for Information Operations and Reports (0704-0188), 1215 Jefferson Davis Highway, Suite 1204, Arlington, VA 22202-4302. Respondents should be aware that notwithstanding any other provision of law, no person shall be subject to a penalty for failing to comply with a collection of information if it does not display a currently valid OMB control number.

PLEASE DO NOT RETURN YOUR FORM TO THE ABOVE ADDRESS.

1. REPORT DATE (DD-MM-YYYY) 27-03-2009		2. REPORT TYPE Master's Thesis		3. DATES COVERED (From - To) August 2007-March 2009		
4. TITLE AND SUBTITLE Optimized Robust Adaptive Networks in Supervisory Control and Data Acquisition Systems				5a. CONTRACT NUMBER		
				5b. GRANT NUMBER		
				5c. PROGRAM ELEMENT NUMBER		
6. AUTHOR(S) Oquendo Class, Luis A., Captain, USAF				5d. PROJECT NUMBER 09-267		
				5e. TASK NUMBER		
				5f. WORK UNIT NUMBER		
7. PERFORMING ORGANIZATION NAMES(S) AND ADDRESS(S) Air Force Institute of Technology Graduate School of Engineering and Management (AFIT/EN) 2950 Hobson Way WPAFB OH 45433-7765 DSN: 785-3636				8. PERFORMING ORGANIZATION REPORT NUMBER AFIT/GE/ENG/09-31		
9. SPONSORING/MONITORING AGENCY NAME(S) AND ADDRESS(ES) Air Force Office of Scientific Research (AFOSR/NL) ATTN: Dr. Robert Bonneau 875 N. Randolph St Ste 325 Rm 3112 Arlington, VA 22203 Com: (703)696-9545 DSN: 426-9545 email:robert.bonneau@afosr.af.mil				10. SPONSOR/MONITOR'S ACRONYM(S)		
12. DISTRIBUTION/AVAILABILITY STATEMENT APPROVED FOR PUBLIC RELEASE; DISTRIBUTION UNLIMITED.				11. SPONSOR/MONITOR'S REPORT NUMBER(S)		
				13. SUPPLEMENTARY NOTES		
14. ABSTRACT This thesis investigates the application of a Exponential Weighted Moving Average (EWMA) to be used as a memory buffer in conjunction with Special Protection Schemes (SPS) using the Electric Power and Communication Synchronizing Simulator (EPOCHS). It is proposed that using an SPS incorporating EWMA can compensate for the network layer lack of guarantee of packet delivery and provide for the stability and integrity of the power grid under a catastrophic event. The performance of the proposed SPS is evaluated using a discrete event computer simulation developed using the NS2 network simulator and the Power System Simulator for Engineering (PSS/E) power system simulator. Performance and metrics evaluated in terms of the SPS's ability to properly calculate disturbance size and to react to the disturbance before the system reaches the minimum frequency threshold of 58.8 HZ and before 0.5 second threshold. Experimental results indicate that the proposed SPS with EWMA can be successfully be applied to ensure power grid stability regardless of network background traffic. The results indicate that the proposed EWMA SPS ensures the protection of the grid. The EWMA SPS has a significant impact on performance when applied to a heavy background traffic network without router reservation enabling it to be stable without the additional hardware cost. Over all, in the tested configuration, the new SPS system successfully maintained steady state operation under all traffic intensities.						
15. SUBJECT TERMS Exponential Weighted Moving Average, Special Protection System, Simulation, Utility Intranet, Supervisory Control and Data Acquisition, Electrical Power Communication and Synchronization Simulator						
16. SECURITY CLASSIFICATION OF:			17. LIMITATION OF ABSTRACT	18. NUMBER OF PAGES	19a. NAME OF RESPONSIBLE PERSON	
REPORT U	ABSTRACT U	c. THIS PAGE U	UU	77	Kenneth M. Hopkinson, PhD, ENG	
			19b. TELEPHONE NUMBER (Include area code) (937) 255-6565; email: kenneth.hopkinson@afit.edu			

Standard Form 298 (Rev. 8-98)

Prescribed by ANSI Std. Z39-18